

Source: T1
Title: Draft TS 34.123-3 v1.0.3
Agenda item: 5.1.4
Document for: Information

3GPP TS 34.123-3 V1.0.~~324~~ (2001-0~~53~~)

Technical Specification

3rd Generation Partnership Project; Technical Specification Group Terminal; User Equipment (UE) conformance specification; Part 3: Abstract Test Suites (Release 1999)



Keywords

ATS, Terminal, Radio, Mobile,
PLMN

3GPP

Postal address

3GPP support office address

650 Route des Lucioles - Sophia
Antipolis
Valbonne - FRANCE
Tel.: +33 4 92 94 42 00 Fax: +33
4 93 65 47 16

Internet

<http://www.3gpp.org>

Copyright Notification

No part may be reproduced except as authorized by written permission.
The copyright and the foregoing restriction extend to reproduction in all media.

© 2000, 3GPP Organizational Partners (ARIB, CWTS, ETSI, T1, TTA, TTC).
All rights reserved.

Contents

Foreword.....	9
Introduction.....	9
1 Scope	10
2 References	10
3 Definitions, symbols and abbreviations.....	11
3.1 Definitions.....	11
3.2 Symbols.....	11
3.3 Abbreviations	12
4 Requirements on the TTCN development.....	12
5 ATS structure.....	12
5.1 Modularity.....	13
5.1.1 Working area structure	13
5.1.2 Contents of the modules	13
5.1.3 Example of a working platform	14
6 Test method and Testing Architecture	14
6.1 Test method.....	14
6.2 Testing Architecture	15
6.2.1 Lower tester	15
6.2.2 Configuration and initialisation	16
6.2.3 Upper tester	16
6.2.4 TTCN	16
6.2.5 Model extension	16
6.2.6 Multiplexing of RLC services.....	16
6.3 NAS test method and architecture.....	17
6.3.1 Test configuration.....	17
6.4 RRC test method and architecture	18
6.4.1 Test configuration.....	18
6.5 RLC test method and architecture	20
6.5.1 Testing architecture	20
6.5.2 Test method	21
6.6 SMS test method and architecture.....	22
6.6.1 SMS CS test method and architecture	22
6.6.2 SMS PS test method and architecture.....	22
6.6.3 SMS Cell broadcasting test method and architecture	22
6.7 MAC test method and architecture	22
6.8 BMC test method and architecture	22
6.9 PDCP test.....	22
7 PCO and ASP definitions	22
7.1 NAS PCO and ASP definitions	22
7.1.1 NAS PCO Definitions.....	22
7.1.2 Primitives used at Dc PCO	23
7.2 Ut PCO and ASP definitions	24
7.2.1 Ut PCO Declarations	24
7.2.2 Primitives used at Ut PCO.....	24
7.3 RRC PCO and ASP definitions.....	25
7.3.1 AM/UM/TM PCO and ASP definitions	25

7.3.1.1	SAP and PCO for data transmission and reception.....	25
7.3.2	Control PCO and ASP	26
7.3.2.1	SAP and PCO for control primitives transmission and reception	26
7.3.2.2	Control ASP Type Definition	26
7.3.2.2.1	CPHY_Cell_Config	26
7.3.2.2.2	CPHY_Cell_TxPower_Modify.....	27
7.3.2.2.3	CPHY_Commit.....	28
7.3.2.2.4	CPHY_Frame_Number.....	28
7.3.2.2.5	CPHY_Out_of_Sync.....	29
7.3.2.2.6	CPHY_RL_Modify.....	29
7.3.2.2.7	CPHY_RL_Release	31
7.3.2.2.8	CPHY_RL_Setup.....	31
7.3.2.2.9	CPHY_Sync.....	36
7.3.2.2.10	CPHY_TrCH_Config	36
7.3.2.2.11	CPHY_TrCH_Release	37
7.3.2.2.12	CMAC_Ciphering_Activate.....	38
7.3.2.2.13	CMAC_Config.....	38
7.3.2.2.14	CMAC_PAGING_Config.....	42
7.3.2.2.15	CMAC_SecurityMode_Config	42
7.3.2.2.16	CMAC_SequenceNumber.....	43
7.3.2.2.17	CMAC_SYSINFO_Config	43
7.3.2.2.18	CRLC_Ciphering_Activate	44
7.3.2.2.19	CRLC_Config.....	45
7.3.2.2.20	CRLC_Integrity_Activate	46
7.3.2.2.21	CRLC_Integrity_Failure	47
7.3.2.2.22	CRLC_Resume	47
7.3.2.2.23	CRLC_SecurityMode_Config.....	48
7.3.2.2.24	CRLC_SequenceNumber.....	48
7.3.2.2.25	CRLC_Status	49
7.3.2.2.26	CRLC_Suspend.....	49
7.3.2.2.27	RLC_TR_DATA.....	50
7.3.2.2.28	RLC_AM_DATA	50
7.3.2.2.29	RLC_UM_DATA	52
7.3.3	Primitives for RLC and RB tests	53
8	Design Consideration	53
8.1	Channel mapping.....	53
8.2	Channel and RB identity	54
8.2.1	Physical Channels.....	58
8.2.2	Transport Channels.....	59
8.2.3	Logical Channels	59
8.2.4	Radio bearers.....	61
8.3	Channels configurations	61
8.3.1	Configuration of Cell_FACH	61
8.3.2	Configuration of Cell_DCH_StandAloneSRB	62
8.3.3	Configuration of Cell_DCH_Speech	63
8.3.4	Configuration of Cell_DCH_64kCSRAB_SRB	64
8.3.5	Configuration of Cell_DCH_57_6kCSRAB_SRB	65
8.3.6	Configuration of Cell_DCH_AM_UM_RAB_7Lis.....	66
8.3.7	Configuration of Cell_DCH_AMRAB_15Lis	67
8.3.8	Configuration of Cell_DCH_UMRAB_15Lis	68
8.3.9	Configuration of Cell_DCH_AMRAB_7_15Lis	69
8.3.10	Configuration of Cell_DCH_UMRAB_7_15Lis	70
8.3.11	Configuration of Cell_FACH_BMC.....	71
8.3.12	Configuration of PS_Cell_FACH.....	72
8.3.13	Configuration of PS_Cell_DCH_64kPSRAB_SRB	73

8.3.14	Configuration of Cell_DCH_Speech_4.75-7.95 kbps	74
8.3.15	Configuration of Cell_single_DTCH (CS)	75
8.4	System information blocks scheduling	76
8.4.1	Grouping SIBs for testing	76
8.4.2	SIB configurations	76
8.4.3	Test SIB schedule for UTRAN/FDD and GERAN system	77
8.4.4	Test SIB schedule for UTRAN FDD system	78
8.4.5	Handling the transmission of SIB	78
8.4.5.1	Delivery of System Information content	78
8.4.5.2	Scheduling of System Information Blocks	79
8.4.5.3	Example of usage	79
8.5	Security in testing	79
8.5.1	Authentication	79
8.5.2	Ciphering	79
8.5.3	Integrity	79
8.5.4	Counter check	80
8.5.5	Test USIM	80
8.6	Downlink power control in SS	80
8.7	Test suite operation definitions	81
8.8	AT commands	87
Annex A (normative): Abstract Test Suites (ATS)		89
A.1	Version of specifications	89
A.2	NAS ATS	89
A.2.1	The TTCN Graphical form (TTCN.GR)	94
A.2.2	The TTCN Machine Processable form (TTCN.MP)	94
A.3	SMS ATS	94
A.3.1	The TTCN Graphical form (TTCN.GR)	95
A.3.2	The TTCN Machine Processable form (TTCN.MP)	95
A.4	RRC ATS	95
A.4.1	The TTCN Graphical form (TTCN.GR)	99
A.4.2	The TTCN Machine Processable form (TTCN.MP)	99
A.5	RLC ATS	99
A.5.1	The TTCN Graphical form (TTCN.GR)	100
A.5.2	The TTCN Machine Processable form (TTCN.MP)	101
A.6	MAC ATS	101
A.7	BMC ATS	101
A.8	PDCP ATS	101
Annex B (normative): Partial IXIT proforma		102
B.0	Introduction	102
B.1	Parameter values	103
B.1.1	L2M Test Suite Parameter Declarations	103
B.1.2	L3M Test Suite Parameters Declarations	106
B.1.3	NAS Test Suite Parameters Declarations	107
B.1.4	SMS Test Suite Parameters Declarations	109
B.1.5	RRC Test Suite Parameters Declarations	110
B.1.5	MMI questions	111

Annex C (informative): Additional information to IXIT.....	117
C.1 Identification Summary	117
C.2 Abstract Test Suite Summary	117
C.3 Test Laboratory.....	117
C.3.1 Test Laboratory Identification	117
C.3.2 Accreditation status of the test service.....	118
C.3.3 Manager of Test Laboratory	118
C.3.4 Contact person of Test Laboratory	118
C.3.5 Means of Testing	119
C.3.6 Instructions for Completion	120
C.4 Client	120
C.4.1 Client Identification	120
C.4.2 Client Test Manager	120
C.4.3 Client Contact person	121
C.4.4 Test Facilities Required	121
C.5 System Under Test.....	122
C.5.1 SUT Information.....	122
C.5.2 Limitations of the SUT	122
C.5.3 Environmental Conditions	123
C.6 Ancillary Protocols	123
C.6.1 Ancillary Protocols 1	124
C.6.2 Ancillary Protocols 2	124
Annex D (informative): PCTR Proforma.....	125
Annex E (informative): TTCN style guide for 3GPP ATS	126
E.1 Introduction	126
E.2 ETR 141 rules and applicability	126
E.2.1 Multiple words are separated by upper case letters at the start of each word	127
E.2.2 Identifiers shall be protocol standard aligned	128
E.2.3 Identifiers shall be distinguishing (use of prefixes)	129
E.2.4 Identifiers should not be too long (use standard abbreviations).....	133
E.2.5 Test suite operations must not use global data.....	136
E.3 3GPP ATS implementation guidelines.....	140
E.3.1 Test case groups shall reflect the TSS&TP document.....	140
E.3.2 Test case names correspond to the clause number in the prose	140
E.3.3 Use standard template for test case and test step header.....	140
E.3.4 Do not use identical tags in nested CHOICE constructions.....	142
E.3.5 Incorrect usage of enumerations	143
E.3.6 Structured type as OCTETSTRING should not be used.....	143
E.3.7 Wildcards in PDU constraints for structured types should not be used	143
E.3.8 TSOs should be passed as many parameters as meaningful to facilitate their implementation	143
E.3.9 Specification of Encoding rules and variation should be indicated	144
E.3.10 Use of global data should be limited	144
E.3.11 Limit ATS scope to a single layer / sub-layer.....	145
E.3.12 Place system information in specially designed data structures.....	145
E.3.13 Place channel configuration in specially designed data structures.....	145
E.3.14 PICS / PIXIT parameters.....	145
E.3.15 Dynamic vs. static choices.....	146

E.3.16	Definition of Pre-Ambls and Post Ambls.....	146
E.3.17	Use test steps to encapsulate AT and MMI commands	146
E.3.18	Use system failure guard timers.....	147
E.3.19	Mapping between prose specification and individual test cases	147
E.3.20	Verdict assignment	147
E.3.20.1	General.....	147
E.3.20.2	Test cases	148
E.3.20.3	Test steps	149
E.3.20.4	Defaults	150
E.3.21	Test suite and test case variables	151
E.3.22	Use of macros is forbidden	151
E.3.23	Support for future Radio Access Technologies	151
E.3.24	Managing multiple representations of the same information.	152
E.3.24.1	Predefined types.....	152
E.3.24.2	Simple types.....	152
E.3.24.3	Structured types	152
E.3.24.4	Conversion responsibility.....	153
E.3.24.5	Option 1: Calling party conversions.....	153
E.3.24.5.1	Advantages.....	153
E.3.24.5.2	Disadvantages	153
E.3.24.6	Option 2: Called party conversions.....	153
E.3.24.6.1	Advantages.....	153
E.3.24.6.2	Disadvantages	154
Annex J (informative): Change history		155

Foreword

This Technical Specification has been produced by the 3rd Generation Partnership Project (3GPP).

The contents of the present document are subject to continuing work within the TSG and may change following formal TSG approval. Should the TSG modify the contents of the present document, it will be re-released by the TSG with an identifying change of release date and an increase in version number as follows:

Version x.y.z

where:

- x the first digit:
 - 1 presented to TSG for information;
 - 2 presented to TSG for approval;
 - 3 or greater indicates TSG approved document under change control.
- y the second digit is incremented for all changes of substance, i.e. technical enhancements, corrections, updates, etc.
- z the third digit is incremented when editorial only changes have been incorporated in the document.

Introduction

The present document is 3rd part of a multi-part conformance test specification for UE. The specification contains a TTCN design frame work and the detailed test specifications in TTCN for UE at the Uu interface.

TS 34.123-1 (part 1) [1] contains a conformance test description in prose for UE at the Uu interface.

TS 34.123-2 (part 2) [2] contains a pro-forma for the UE Implementation Conformance Statement (ICS).

1 Scope

The present document specifies the protocol conformance testing in TTCN for the 3GPP User Equipment (UE) at the Uu interface.

The document is the 3rd part of a multi-part test specification, TS 34.123. The following information can be found in this part:

- The overall test suite structure;
- The testing architecture
- The test methods and PCO definitions;
- The test configurations;
- The design principles, assumptions, and used interfaces to the TTCN tester;
- TTCN styles and conventions,
- The partial PIXIT proforma;
- The TTCN.MP and TTCN.GR forms for the mentioned protocols tests.

The Abstract Test Suites designed in the document are based on the test cases specified in prose [1].

2 References

The following documents contain provisions, which, through reference in this text, constitute provisions of the present document.

- References are either specific (identified by date of publication, edition number, version number, etc.) or non-specific.
- For a specific reference, subsequent revisions do not apply.
- For a non-specific reference, the latest version applies.

- [1] 3GPP TS 34.123-1: "UE Conformance Specification, Part 1 - Protocol conformance specification".
- [2] 3GPP TS 34.123-2: "UE Conformance Specification, Part 2 - ICS proforma".
- [3] 3GPP TS 34.108: "Common Test Environments for UE Conformance Testing".
- [4] 3GPP TS 34.109: "Logical Test Interface (TDD and FDD)".
- [5] 3GPP TR 21.905: "Vocabulary for 3GPP Specifications".
- [6] 3GPP TS 23.003: "Numbering, Addressing and Identification".
- [7] 3GPP TS 23.101: "General UMTS Architecture".
- [8] 3GPP TS 24.007: "Mobile Radio Interface Signalling Layer 3; General Aspects".
- [9] 3GPP TS 24.008: "Mobile Radio Interface Layer 3 specification; Core Network Protocols -Stage 3".

- [10] 3GPP TS 24.011: "PP SMS support on the Mobile radio Interface".
- [11] 3GPP TS 24.012: "SMS-SCB support on the Mobile radio Interface".
- [12] 3GPP TS 25.214: "FDD; physical layer procedures".
- [13] 3GPP TS 25.224: "TDD; physical layer procedures".
- [14] 3GPP TS 25.301: "Radio Interface Protocol Architecture".
- [15] 3GPP TS 25.303: "Interlayer Procedures in Connected Mode".
- [16] 3GPP TS 25.304: "UE Procedure in Idle Mode and Procedures in Connected Mode".
- [17] 3GPP TS 25.321: "MAC Protocol Specification".
- [18] 3GPP TS 25.322: "Radio Link Control (RLC) Protocol Specification".
- [19] 3GPP TS 25.323: "Packet Data Convergence Protocol (PDCP) Specification".
- [20] 3GPP TS 25.324: "Radio Interface for Broadcast and Multicast Services".
- [21] 3GPP TS 25.331: "Radio Resource Control (RRC) Protocol Specification".
- [22] 3GPP TS 27.005: "Use of Data Terminal Equipment - Data Circuit terminating; Equipment (DTE - DCE) interface for Short Message Service (SMS) and Cell Broadcast Service (CBS)".
- [23] 3GPP TS 27.007: "AT command set for User Equipment (UE)".
- [24] 3GPP TS 27.060: "Mobile Stations (MS) supporting packet switched services".
- [25] 3GPP TS 33.102: "Security architecture".
- [26] 3GPP TS 51.010-1: "Mobile Station (MS) Conformance Specification".
- [27] ETSI TR 101 666 (V1.0.0): "The Tree and Tabular Combined Notation (TTCN) (Ed. 2++)".
- [28] [ITU-T Recommendation X.691, \(12/97\) "Information technology - ASN.1 encoding rules - Specification of Packed Encoding Rules \(PER\)".](#)

3 Definitions, symbols and abbreviations

3.1 Definitions

For the purposes of the present document, the following terms and definitions apply:

tbid.

3.2 Symbols

For the purposes of the present document, the following symbols apply:

<symbol> <Explanation>

3.3 Abbreviations

For the purposes of the present document, the following abbreviations apply:

<ACRONYM> <Explanation>

4 Requirements on the TTCN development

A number of requirements are identified for the development and production of TTCN specification for 3GPP UE at Uu interface.

1. Top-down design, following 3GPP TS 34.123-1[1], 3GPP TS 34.108[3] and 3GPP TS 34.109[4].
2. A unique testing architecture and test method for testing all protocol layers of UE,
3. Uniform TTCN style and naming conventions,
4. Improve TTCN readability,
5. Using TTCN-2++ (ETSI TR 101 666 [27]) for R99, avoid the use of the TTCN 2 features TTCN 3 does not support.
6. TTCN specification feasible, implementable and compilable,
7. Test cases shall be designed in a way for easily adaptable, upwards compatible with the evolution of the 3GPP core specifications and the future Releases.
8. The test declarations, data structures and data values shall be largely reusable.
9. Modularity and modular working method,
10. NAS ATS should be designed being independent from the radio access technologies.
11. Minimising the requirements of intelligence on the emulators of the lower testers. Especially the functionality of the RRC emulator in the TTCN tester should be reduced and simplified, the behaviours should be standardised as the TTCN RRC test steps in the TTCN modular library.
12. Giving enough design freedom to the test equipment manufacturers.
13. Maximising reuse of ASN.1 definitions from the relevant core specifications.

In order to fulfil these requirements and to ensure the investment of the test equipment manufacturers having a stable testing architecture for a relatively long period, a unique testing architecture and test method are applied to the 3GPP UE protocol tests.

5 ATS structure

The total TTCN specification for the UE testing is structured in a number of separate layered ATSs. The number of ATS being produced corresponds to the number of the 3GPP core specifications referred. The separation of ATSs reduces the size of ATSs. The layer-specific test preambles and test data can be confined to one test suite and parallel development of test suites can be facilitated. The separation of ATSs enables also easily to follow the evolution of the core specifications.

NAS ATSs

- 1) GSM MAP L3 ATS including MM, CC, GMM, SM test groups,
- 2) SMS ATS,

AS ATSS

- 1) RRC ATS including Idle mode test group,
- 2) RLC ATS,
- 3) MAC ATS
- 4) BMC ATS
- 5) PDCP ATS,
- 6) Intersystem ATS including the idle mode and handover test groups.

5.1 Modularity

The modular TTCN approach is used for the development of the 3GPP ATS specification work. Two modules, L2M and L3M are installed.

5.1.1 Working area Module structure

The working area is shown in Figure 1.

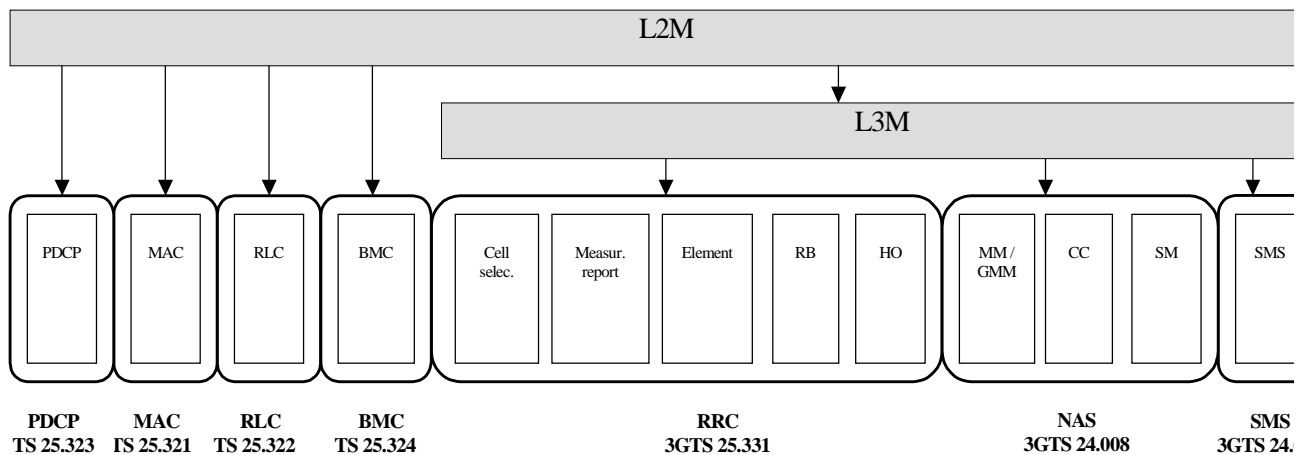

Figure 1: The proposed working area

The L2M (Layer 2 Module) is a minimum module commonly for the layer 2 and layer 3 testing. The L3M (Layer 3 Module) contains all the items to be shared by the RRC, NAS and SMS ATSS.

5.1.2 Contents of the modules

The L2M module includes objects related to the RRC, the layer 2 and the physical layer. It includes also all test steps needed by the layer 2 and layer 3 test cases for configurations and all objects related to the definition of the steps:

- Common test steps and default test steps defined as generic procedures in 3GPP TS 34.108[3];
- RRC declarations related to the steps: types, timers, PDU types, ASP type, PCOs, TSOs, constants;
- Related ICS and IXIT parameters needed for testing and respectively defined in 3GPP TS 34.123-2[2] and the present document;
- Defaults constraints based on the default message contents defined in 3GPP TS 34.108[3],

- MMI PCO and ASPs,
- All TTCN objects related to the SS configuration, e.g. PCOs, declaration of the components.

The L3M module includes the NAS configuration steps and all related TTCN objects:

- Common test steps and default test steps defined as generic procedures in 3GPP TS 34.108[3];
- NAS declarations related to these steps: types, PDU, ASP, PCOs, TSOs, constants;
- Related ICS and IXIT parameters needed for testing and respectively defined in 3GPP TS 34.123-2[2] and the present document;
- Default constraints based on the default message contents defined in 3GPP TS 34.108[3].

5.1.3 Example of a working platform

The figure 2 below shows the working platform for the user that is writing the RRC test cases.

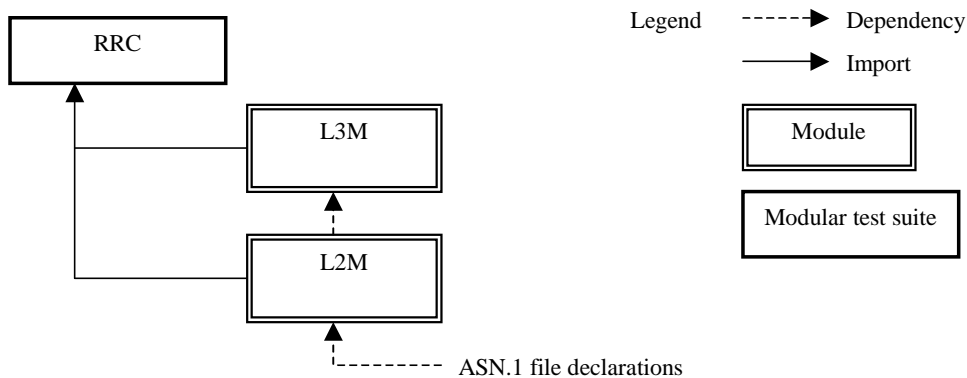

Figure 2: An example of working platform for RRC

6 Test method and Testing Architecture

6.1 Test method

The distributed single party test method is used for the UE testing. The lower tester configures the emulator and communicates with the UE under test via the emulator. An upper tester interfaces UE as (E)MMI..

All common parts in 3GPP TS 34.108 [3], 3GPP TS 34.109 [4] and 3GPP TS 34.123-2 [2] will be developed in a TTCN library including the declarations, default constraints, preambles and postambles. They have the following characteristics:

Very complex,

Worked in different layers,

Including data representing the radio parameters for SS setting and the data representing the UE capabilities (PICS parameters),

Including the generic procedures to bring the UE into certain test states or a test mode (C-plane),

Setting RABs at U-plane and SRBs in C-plane,

Being used by every test cases no matter which layer the test case belongs to,

No affect on the test verdict of PASS or FAIL.

The layer-specific test cases have the characteristics:

- - relatively simple and straight forward,
- - having narrow test scope and test purposes
- - test scenarios in a single layer (one PCO)
- - assigning the test verdict

6.2 Testing Architecture

A unique testing architecture is shown in the following figure.

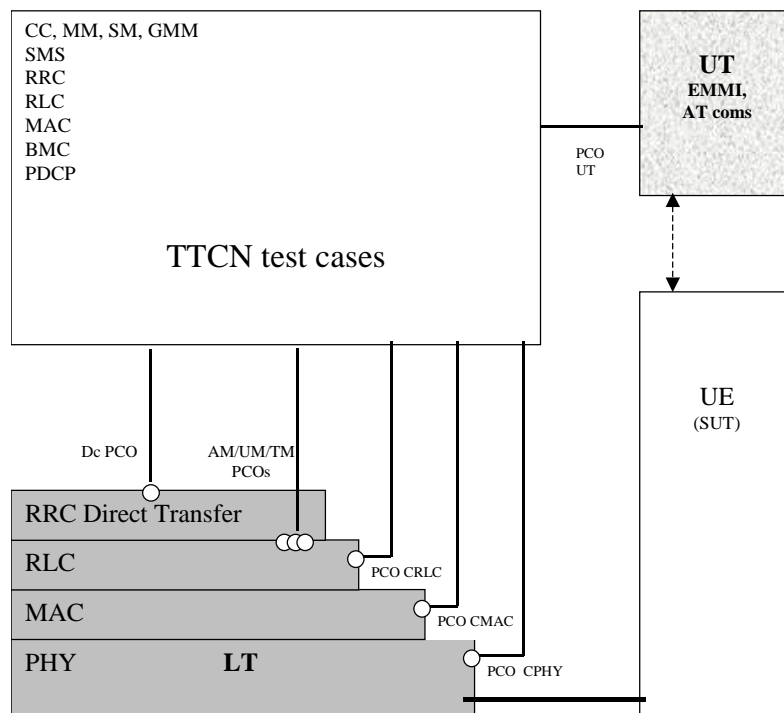

Figure 3: A unique testing architecture

6.2.1 Lower tester

The lower tester (LT) provides the test means for the execution of the test cases for CC, SM, MM, GMM, SMS, RRC, RLC, MAC, PDCP or BMC. The LT provides also the RLC, MAC and PHY emulators to communicate with the UE. The configuration and initialisation of the emulators are control by the TTCN via ASPs.

6.2.2 Configuration and initialisation

A number of TTCN test steps are designed for the generic setting.

- 1) Configuration of L1 of the tester, such as the cells, Physical channels and common transport channels via CPHY-PCO, configuration of MAC via CMAC-PCO and configuration of RLC layer via CRLC-PCO,
- 2) Sending system information via TR-PCO,
- 3) Establishment RRC connection via AM or UM-PCO,
- 4) Assigning a radio bearer via AM-PCO,
- 5) MM /GMM registration via Dc-PCO,
- 6) Establishment of a CS call or a PDP context via Dc-PCO,
- 7) Setting security parameters and control of integrity via CRLC- and ciphering via CRLC- and CMAC-PCO.

6.2.3 Upper tester

An upper tester (UT) exists in the test system. The UT interfaces toward UE with any optional EMMI (34.109, clause 7 [4]). TTCN communicates with the UT by passing coordination primitives via a Ut PCO. The primitives can either contain AT commands aiming at the automatic tests, or some informal commands as MMI, in order to request the UE for certain actions and to provide simple means for observations of UE.

6.2.4 TTCN

TTCN is used as specification language based on ETSI TR 101 666 [27] (TTCN 2++). The importation of ASN.1 modules and modular TTCN are two of the most important features used in the design of the ATSS.

The TTCN test suites have been designed to maximise the portability from the language TTCN 2 to TTCN 3.

6.2.5 Model extension

If a test case needs to handle a concurrent situation two or more LTs can be configured at the same time. The following test scenarios identified may require multiple testers in the test configuration.

- 1) Multiple cells HO tests,
- 2) Intersystem Idle mode and Handover tests.

6.2.6 Multiplexing of RLC services

For the RRC and NAS testing, the TTCN RRC test steps and the RRC emulator may share the same service access point (AM SAP). The RLC emulator shall provide separate message queues (buffers) for the TTCN RRC test steps and the RRC emulator for the TTCN NAS test cases, according to the signalling radio bearer identities.

6.3 NAS test method and architecture

6.3.1 Test configuration

The NAS test method is shown in figure 4.

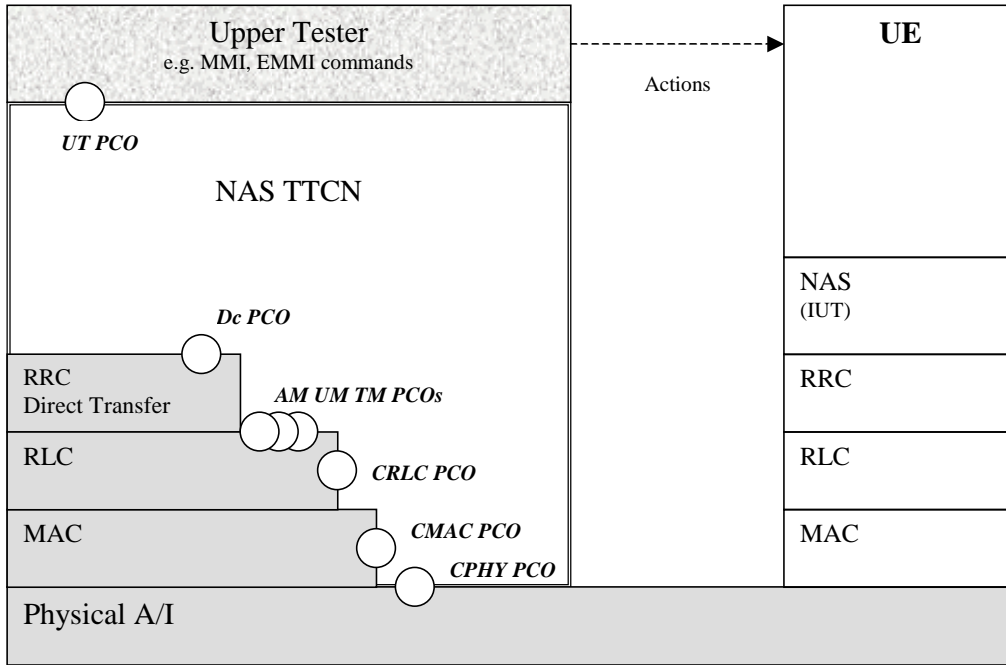

Figure 4: NAS testing architecture

The single layer distributed test method is used.

The Point of Control and Observation (PCO) are defined as the Dc (Dedicated control) SAP. The NAS test verdicts are assigned depending on the behaviours observed at the PCO.

The TTCN tester provides the NAS TTCN test cases and steps with a simple RRC direct transfer function which buffers the NAS PDU data, converts the data from the NAS TTCN table format into ASN.1, or in reverse way, and delivers all lower layer services of AM-SAP for RB3 and RB4.

The NAS TTCN test cases make also intensively use of the RRC TTCN test steps, in order to:

- Configure, initialise and control the L2 emulator,
- Initialise the UE for testing.

The RRC test steps, which are called by the NAS test cases or steps, interface with the RLC PCOs (UM, AM and TR), the control PCOs CRLC, CMAC and CPHY.

The General control (Gc) SAP and the Notification (Nt) SAP are not applied. Messages exchanged via these SAPs will be replaced with the corresponding RRC TTCN test steps.

The Ut PCO (so called logical interface [4]) is served as the interface to the UE EMMI to allow a remote control of operations, which have to be performed during execution of a test case such as to switch the UE on/off, initiate a call, etc.

6.4 RRC test method and architecture

6.4.1 Test configuration

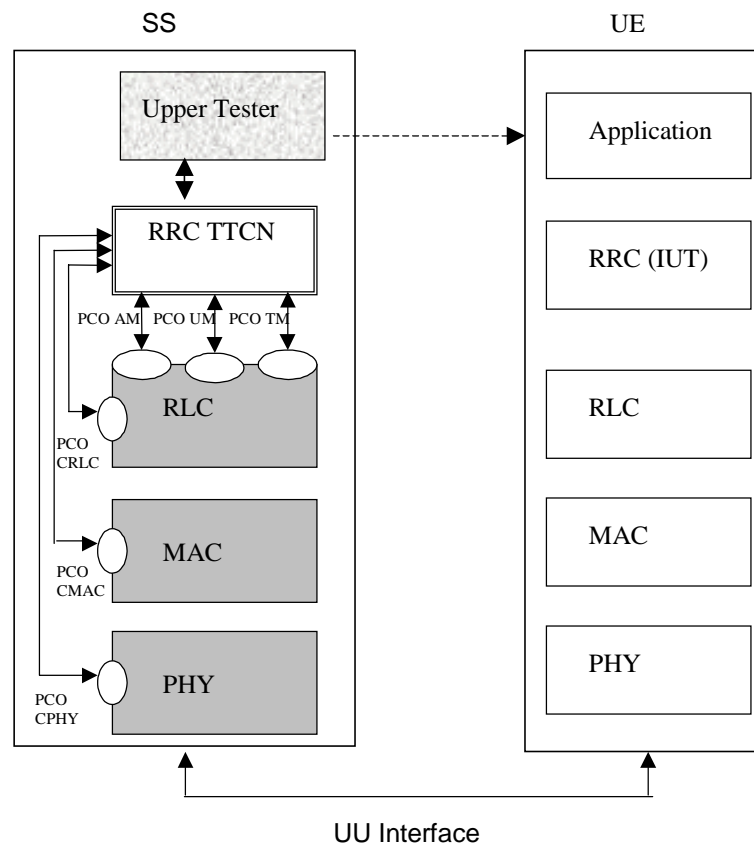

Figure 5: RRC testing architecture

The single layer distributed test method is used.

The PCOs are defined as the AM (Acknowledged Mode), UM (Unacknowledged Mode) and TM (Transparent Mode) SAPs. The RRC test verdicts are assigned depending on the behaviours observed at the PCO. The RRC TTCN interface also with the control PCOs CRLC, CMAC and CPHY, for the configuration, initialisation and control of the System Simulator.

The RRC TTCN test cases also make use of the NAS TTCN test steps in order to:

- Bring UE to Idle state,
- Bring UE to state U10

The NAS test steps, which are called by the RRC test cases or steps, interface with the Dc PCO.

The Ut PCO (so called logical interface [4]) is served as the interface to the UE EMMI to allow a remote control of operations, which have to be performed during execution of a test case such as to switch the UE on/off, initiate a call, etc.

According to TS 25.331 [21] clause 12.1.1, the encoding of RRC PDUs is obtained by applying UNALIGNED PER to the abstract syntax value as specified in X.691 [28]. The two tables below show the declaration of the encoding rule and an example of the use in the definition of an RRC PDU.

Table 1: PER Unaligned Encoding Rule

Encoding Rule Name	PER_Unaligned
Reference	X.691
Default	
Comments	Packet encoding rules (X.691) unaligned and with adapted padding

Table 2: Definition of the RRC constraint cbs_RRC_RrcConnRelease_DCCH

Constraint Name	cbs_RRC_RrcConnRelease_DCCH (p_RRC_Ti: RRC_TransactionIdentifier; p_N308: INTEGER; p_RelCause : ReleaseCause)
PDU Type	Message
Derivation Path	
Encoding Rule Name	PER_Unaligned
Encoding Variation	
Comments	
Constraint Value	
<pre> dL_DCCH_Message :{ integrityCheckInfo cs_IntegrityCheckInfo, message_rrcConnectionRelease_r3{ --RRCConnectionRelease_r3 rrcConnectionRelease_r3 { rrc_TransactionIdentifier p_RRC_Ti, n_308 p_N308, releaseCause p_RelCause }, nonCriticalExtensions OMIT } } </pre>	

6.5 RLC test method and architecture

6.5.1 Testing architecture

Figure 6 illustrates a typical realisation of the RLC ATS.

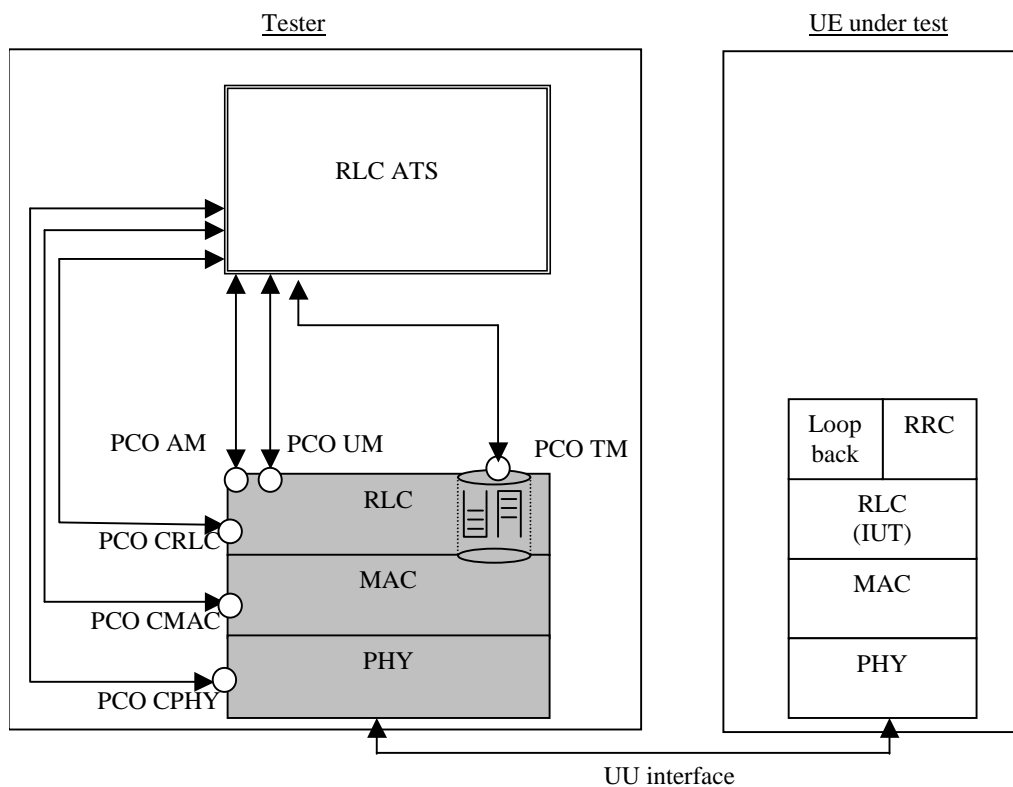

Figure 6: RLC ATS single party test method

The single party test method is used for RLC testing.

Separation of TTCN test cases from the configuration of the tester and initialisation of the UE is achieved by using test steps. For each RLC test case, common test steps will be used to perform the configuration of the tester and the appropriate generic setup procedures as described in 3GPP TS 34.108. These test steps will make use of PCOs AM, UM, TM, CRLC, CMAC, and CPHY.

Three PCOs are provided at the top of the RLC emulation in the tester, one corresponding to each of the available RLC modes: acknowledged, unacknowledged, and transparent. Routing information for different radio bearers used at these PCOs will be provided in ASP parameters.

The queues shown in the RLC emulation in figure 6 indicate that normal RLC transmit and receive buffering will be used to isolate the TTCN test suite from the real time issues involved if messages are sent directly to the MAC layer.

The RLC TTCN test cases make also use of the NAS TTCN test steps in order to bring UE to Idle state. The NAS test steps, which are called by the RLC test cases or steps, interface with the Dc PCO.

6.5.2 Test method

Figure 7 illustrates an example configuration for downlink UM testing. Uplink and AM tests will use similar configurations. A Tr-Entity is established on the tester side using a CRLC-CONFIG-REQ. A corresponding UM-Entity is created in the UE by sending a Radio Bearer Setup PDU. RLC PDUs are specified in the TTCN test suite, and sent to TM PCO. These PDUs shall be carefully designed so that the Tr-Entity will not perform any segmentation. To test reassembly in the UE side, the segmentation must be explicitly coded in TTCN. To test various aspects of the RLC header (e.g. sequence numbering, length indications etc), the RLC header must be explicitly coded in TTCN. Ciphering will not be tested using this approach, and will be disabled in the UE UM Entity.

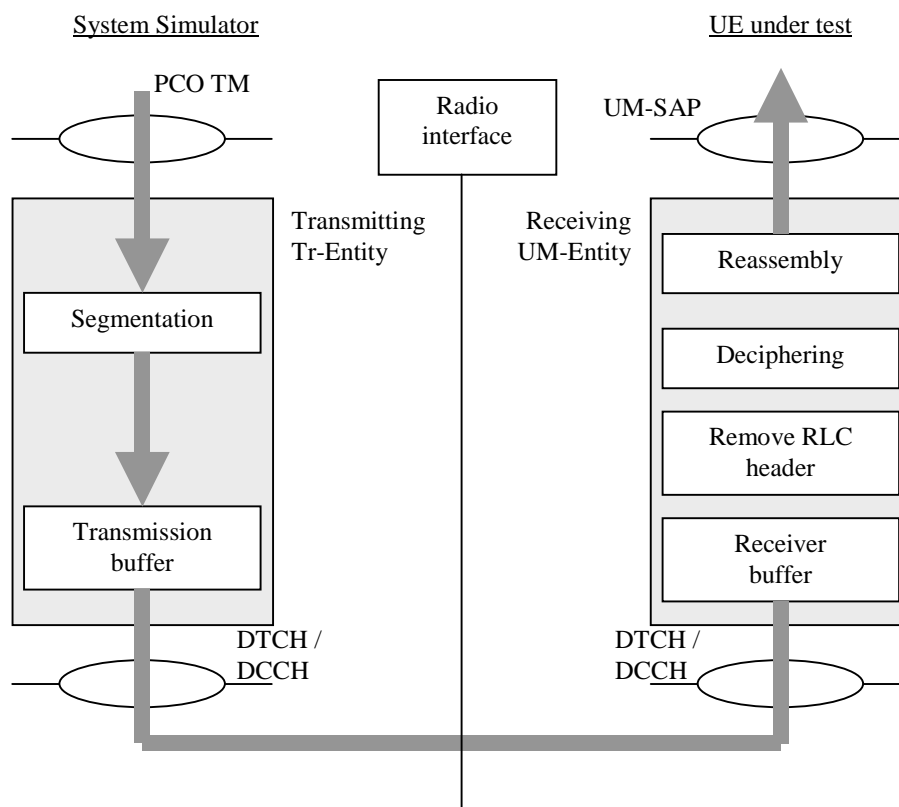

Figure 7: Example configuration for downlink RLC UM testing

All RLC tests that require uplink data will make use of the UE test loop mode 1 defined in 3GPP TS 34.109 [4]. The UE test loop mode 1 function provides all upper uester (UT) functionality required, so an Ut PCO is not required for RLC tests. Test Loop mode 1 is only available in the user plane, so all RLC tests will be performed in the user plane, using DTCH and DCCH logical channels mapped to DCH transport channels.

Ciphering tests will be performed using the PCOs UM and AM, with the UE test loop mode configured to ensure that uplink and downlink PUs are different sizes. Pseudo random data will be transmitted from the TTCN test case, ciphered by the SS RLC emulation UM or AM entity, and sent to the UE. The UE will then decipher, loop back (with different PU size), and cipher the data, and return it to the SS. The SS RLC UM or AM entity will then decipher the data, and pass it back to the TTCN, which will verify that the received data is identical to the transmitted data.

6.6 SMS test method and architecture

6.6.1 SMS CS test method and architecture

The test method used for SMS CS tests is the same as the NAS test method, see clause 6.3, and the same ASPs, see clause 7.1.2.

6.6.2 SMS PS test method and architecture

tbd

6.6.3 SMS Cell broadcasting test method and architecture

tbd

6.7 MAC test method and architecture

tbd

6.8 BMC test method and architecture

tbd

6.9 PDCCP test

tbd

7 PCO and ASP definitions

7.1 NAS PCO and ASP definitions

7.1.1 NAS PCO Definitions

Table 3: Dc PCO Type Declarations

PCO Type Declarations	
PCO Type	Dc_SAP
Role	LT
Comments	The PCO type for NAS testing

Table 4: Dc PCO Declarations

PCO Declarations	
PCO Name	Dc
PCO Type	Dc_SAP
Role	LT
Comments	Carry transmission and reception of NAS messages

7.1.2 Primitives used at Dc PCO

The Dc PCO is used to transmit and receive NAS (MM, CC, SM, SS) messages. Two categories of primitives are operated at the Dc PCO:

RRC_DataReq for transmission of a NAS PDU;

RRC_DataInd for reception of a NAS PDU.

These primitives are declared in TTCN tabular form, see the following table.

Table 5: Primitives used at the Dc PCO

Primitive	Parameters	Use
RRC_DataInd	Cell identity RB identity LogicChGSM SapId CN domain id NAS message	The ASP is used to indicate the receipt of a NAS message using acknowledged operation
RRC_DataReq	Cell identity RB Identity LogicChGSM SapId CN domain id NAS message	The ASP is used to request the transmission of a NAS message using acknowledged operation.

The RB Identity and CN domain parameters defined in the primitives are mandatory for UTRAN and not applicable for GERAN.

The LogicChGSM and SapId parameters are mandatory for GERAN and not applicable for UTRAN. They are defined because they may be used for future TTCN test cases.

Except the initial, uplink and downlink direct transfer procedures, the NAS TTCN specification uses the TTCN test steps to realise all RRC functions for testing. The single layer test concept is kept for the NAS tests.

A simple RRC emulation shall be maintained for the NAS tests. It has four functions.

- Emulate the three direct transfer procedures,
- Convert the NAS downlink messages defined in 24.008 in table format to the NAS message in ASN.1 octet string specified in 25.331. Convert the NAS uplink message in the reverse way.
- PER encoding and decoding,
- Have the integrity protection.

RB3 and RB4 are specifically used for the NAS signalling. When an uplink message entered the receiving buffer at AM-SAP from the RLC emulation, either an RRC test step if running will take it out;

or the RRC emulation if running will pick the received message from the buffer. Activation of any RRC test steps and activation of any NAS test steps at the same time shall be excluded in TTCN (no concurrency between them).

7.2 Ut PCO and ASP definitions

7.2.1 Ut PCO Declarations

The Ut PCO is served as the interface to the UE EMMI for remote control of operations, which have to be performed during execution of a test case such as to switch the UE on/off, initiate a call, etc.

Table 6: Declaration of the uppertester PCO type

PCO Type Declarations	
PCO Type	MMI
Role	UT
Comments	The PCO type for MMI or EMMI of the upper tester

Table 7: Declaration of the Ut PCO

PCO Declarations	
PCO Name	Ut
PCO Type	MMI
Role	UT
Comments	Carry transmission commands and reception of results for the upper tester

7.2.2 Primitives used at Ut PCO

The Ut PCO is used to indicate to the upper tester actions and to receive the acknowledgement of these actions. The AT commands are used wherever the suitable commands exist within 3GPP TS 27.007 [23], 3GPP TS 27.005 [22] and 3GPP TS 27.060 [24]. An MMI command is used, when AT commands does not exist for the action to be performed. The primitives used at the Ut PCO, are declared in TTCN tabular form, see the following table.

Table 8: Primitives used at the Ut PCO

Primitive	Parameters	Use
AT_CmdReq	Command: IA5String SMS_BlockMode: HEXSTRING	Request an AT command to the upper tester.
AT_CmdInd	Command: IA5String SMS_BlockMode: HEXSTRING	Indication of a result from the upper tester.
AT_CmdCnf	Result: BOOLEAN ResultString: IA5String SMS_BlockMode: HEXSTRING	Return a positive or negative result from the command previously sent. Both the boolean result and String parameter are optional.
MMI_CmdReq	Command: IA5String	Request a command to the upper tester.
MMI_CmdCnf	Result: BOOLEAN ResultString: IA5String	Return a positive or negative result from the command previously sent. The String parameter is optional.

The AT_CmdReq primitive for sending AT commands is mostly used to trigger electronically an uplink access, such as initiating of a call, attaching or detaching, starting packet data transfer etc. The MMI_

primitive is defined mainly for observation of some test events via a test operator, such as checking DTMF tone or checking called party number, etc.

The AT_CmdInd primitive for receiving AT commands is mostly used to transfer unsolicited result codes from the UE to the lower tester.

The SMS_BlockMode parameter is used to control and observe the Block mode procedure for SMS. This parameter is not yet used; it is defined for future development. The Command and SMS_BlockMode parameters are mutually exclusive

For the Command in the AT_CmdReq and AT_CmdInd primitives, the verbose format is used as defined in 3GPP TS 27.007. For the Command in MMI_CmdReq, just a descriptive IA5 string line, like "Check DTMF tone" is used.

7.3 RRC PCO and ASP definitions

7.3.1 AM/UM/TM PCO and ASP definitions

7.3.1.1 SAP and PCO for data transmission and reception

Table 9: Declaration of the RRC PCO Type

PCO Type Definition	
PCO Type	DSAP
Role	LT
Comment	DATA transmission and reception

Table 10: PCO TM declaration

PCO Type Definition	
PCO Name	TM
PCO Type	DSAP
Role	LT
Comment	Carry Transparent Mode RLC PDU

Table 11: PCO AM declaration

PCO Type Definition	
PCO Name	AM
PCO Type	DSAP
Role	LT
Comment	Carry Acknowledged Mode RLC PDU

Table 12: PCO UM declaration

PCO Type Definition	
PCO Name	UM
PCO Type	DSAP
Role	LT
Comment	Carry Unacknowledged Mode RLC PDU

ASN.1 ASP Type Definition	
Type Name	CPHY_Cell_Config_REQ
PCO Type	CSAP
Comment	To request to setup the cell parameter
Type Definition	
SEQUENCE {	
cellId	INTEGER(0..15),
tcell	INTEGER(0..38399),
sfnOffset	INTEGER(0 .. 4095)
frequencyInfo	FrequencyInfo,
primaryScramblingCode_SS	INTEGER(0..511),
cellTxPowerLevel	CellTxPowerLevel,
dLtxAttenuationLevel	INTEGER(0..30)
}	

ASN.1 Type Definition	
Type Name	CellTxPowerLevel
Comment	The defaultCellTxPowerLvl is a default setting and is used for the most signalling tests. The real total cell DL Tx power level equals to the sum of the DL Tx power of the individual physical channels configured. The totalCellTxPowerLvl applies to e.g. the idle mode tests in a non-default multi-cell radio environment.
Type Definition	
CHOICE {	
defaultCellTxPowerLvl	NULL,
totalCellTxPowerLvl	DL_TxPower
}	

7.3.2.2.1a CPHY_Ini

ASN.1 ASP Type Definition	
Type Name	CPHY_Ini_REQ
PCO Type	CSAP
Comment	Request to initialise the test
Type Definition	
ENUMERATED {	
defaultRadioEnvironment(0),	nonDefaultMultiCell(1)
}	

ASN.1 ASP Type Definition	
Type Name	CPHY_Ini_CNF
PCO Type	CSAP
Comment	Confirm the test initialisation
Type Definition	

7.3.2.2.2 CPHY_Cell_TxPower_Modify

ASN.1 ASP Type Definition	
Type Name	CPHY_Cell_TxPower_Modify_CNF
PCO Type	CSAP
Comment	To confirm to change the DL power
Type Definition	
SEQUENCE {	
cellId	INTEGER(0..15)
}	

ASN.1 ASP Type Definition	
Type Name	CPHY_Cell_TxPower_Modify_REQ
PCO Type	CSAP
Comment	To request to change the DL power
Type Definition	
SEQUENCE	{
	cellId INTEGER(0..15),
	dLTxAttenuationLevel INTEGER(0..30)
	}

7.3.2.2.3 CPHY_Commit

ASN.1 ASP Type Definition	
Type Name	CPHY_Commit_CNF
PCO Type	CSAP
Comment	Confirm the commit request
Type Definition	
SEQUENCE	{
	cellId INTEGER(0..15),
	routingInfo RoutingInfo
	}

ASN.1 ASP Type Definition	
Type Name	CPHY_Commit_REQ
PCO Type	CSAP
Comment	To request the timing to modify the Radio Link
Type Definition	
SEQUENCE	{
	cellId INTEGER(0..15),
	routingInfo RoutingInfo,
	activationTime INTEGER(0..255)
	}

7.3.2.2.4 CPHY_Frame_Number

ASN.1 ASP Type Definition	
Type Name	CPHY_Frame_number_CNF
PCO Type	CSAP
Comment	To return the requested frame number
Type Definition	
SEQUENCE	{
	cellId INTEGER(0..15),
	routingInfo RoutingInfo,
	frameNumber INTEGER(0..255)
	}

7.3.2.2.7 CPHY_RL_Release

ASN.1 ASP Type Definition	
Type Name	CPHY_RL_Release_CNF
PCO Type	CSAP
Comment	PHY emulator confirms that a specified physical channel has been released.
Type Definition	
SEQUENCE	{
cellId	INTEGER(0..15),
routingInfo	RoutingInfo,
}	}

ASN.1 ASP Type Definition	
Type Name	CPHY_RL_Release_REQ
PCO Type	CSAP
Comment	To request to release the Radio Link
Type Definition	
SEQUENCE	{
cellId	INTEGER(0..15),
routingInfo	RoutingInfo
}	}

7.3.2.2.8 CPHY_RL_Setup

ASN.1 ASP Type Definition	
Type Name	CPHY_RL_Setup_CNF
PCO Type	CSAP
Comment	To confirm to setup the Radio Link
Type Definition	
SEQUENCE	{
cellId	INTEGER(0..15),
routingInfo	RoutingInfo
}	}

ASN.1 ASP Type Definition	
Type Name	CPHY_RL_Setup_REQ
PCO Type	CSAP
Comment	To request to setup the associated transport channels and the Radio Link itself.
Type Definition	
SEQUENCE	{
cellId	INTEGER(0..15),
routingInfo	RoutingInfo,
ratType	RatType,
setupMessage	CphyRlSetupReq
}	}

ASN.1 Type Definition	
Type Name	CphyRISetupReq
Comment	To request to setup the Radio Link
Type Definition	
<pre> SEQUENCE { physicalChannelInfo CHOICE { primaryCPICHInfo, secondaryCPICHInfo, primarySCHInfo, secondarySCHInfo, primaryCCPCHInfo, secondaryCCPCHInfo, pRACHInfo, pICHInfo, aICHInfo, dPCHInfo, -- pCPCHInfo, -- aP_ICHInfo, -- cD_ICHInfo, -- cD_CA_ichInfo, -- cSICHInfo, -- pDSCHInfo, -- pUSCHInfo } } </pre>	

ASN.1 Type Definition	
Type Name	PrimaryCPICHInfo
Comment	
Type Definition	
<pre> SEQUENCE { dl_TxPower_PCPICH DL_TxPower_PCPICH, tx_diversityIndicator BOOLEAN } </pre>	

ASN.1 Type Definition	
Type Name	SecondaryCPICHInfo
Comment	
Type Definition	
<pre> SEQUENCE { scramblingCode INTEGER{0..15}, dl_ChannelizationCode SF512_AndCodeNumber, dl_TxPower DL_TxPower } </pre>	

ASN.1 Type Definition	
Type Name	PrimarySCHInfo
Comment	
Type Definition	
<pre> SEQUENCE { tstdIndicator BOOLEAN, dl_TxPower DL_TxPower } </pre>	

ASN.1 Type Definition	
Type Name	SecondarySCHInfo
Comment	
Type Definition	
SEQUENCE {	tstdIndicator BOOLEAN, dl_TxPower DL_TxPower
}	

ASN.1 Type Definition	
Type Name	PrimaryCCPCHInfo
Comment	
Type Definition	
SEQUENCE {	sttd_Indicator BOOLEAN, dl_TxPower DL_TxPower
-- timeSlot	TimeSlot OPTIONAL,
-- burstType	BurstType OPTIONAL,
-- offset	Offset OPTIONAL,
-- repetitionPeriod	RepetitionPeriod OPTIONAL,
-- repetitionLength	RepetitionLength OPTIONAL,
}	

ASN.1 Type Definition	
Type Name	SecondaryCCPCHInfo
Comment	
Type Definition	
SEQUENCE {	scramblingCode INTEGER(0..15), dl_ChannelizationCode SF512_AndCodeNumber, sCCPCHSlotFormat SCCPCHSlotFormat, timingOffset INTEGER (0..149), positionFixedOrFlexible PositionFixedOrFlexible, sttd_Indicator BOOLEAN, dl_TxPower DL_TxPower, powerOffsetOfTFCI_P01 INTEGER (0..50), powerOffsetOfPILOT_PO3 INTEGER (0..50)
-- timeSlot	TimeSlot OPTIONAL,
-- burstType	BurstType OPTIONAL,
-- midambleShift	MidambleShift OPTIONAL,
-- offset	Offset OPTIONAL,
-- repetitionPeriod	RepetitionPeriod OPTIONAL,
-- repetitionLength	RepetitionLength OPTIONAL,
-- tFCIPresence	TFCIPresence OPTIONAL,
}	

ASN.1 Type Definition	
Type Name	PRACHInfo
Comment	
Type Definition	
<pre> SEQUENCE { fdd_tdd fdd SEQUENCE { preambleSignature spreadingFactorForDataPart preambleScramblingCode puncturingLimit accessSlot }, tdd SEQUENCE { -- timeSlot -- spreadingCode -- midambleCode } } </pre>	
	<pre> CHOICE { AvailableSignatures, SF_PRACH, PreambleScramblingCodeWordNumber, PuncturingLimit, AvailableSubChannelNumbers } </pre>

ASN.1 Type Definition	
Type Name	PICHInfo
Comment	
Type Definition	
<pre> SEQUENCE { pichinfo dl_TxPower } </pre>	
	<pre> PICH_Info, DL_TxPower </pre>

ASN.1 Type Definition	
Type Name	AICHInfo
Comment	
Type Definition	
<pre> SEQUENCE { aichinfo dl_TxPower } </pre>	
	<pre> AICH_Info, DL_TxPower </pre>

ASN.1 Type Definition	
Type Name	DPCHInfo
Comment	At least one of the fields shall be present.
Type Definition	
<pre> SEQUENCE { ul_DPCH_Info dl_DPCHInfo } </pre>	
	<pre> UL_DPCH_Info OPTIONAL, DL_DPCHInfo OPTIONAL </pre>

ASN.1 Type Definition	
Type Name	DL_DPCHInfo
Comment	
Type Definition	
<pre>SEQUENCE { dl_CommonInformation DL_CommonInformation, dl_DPCH_InfoPerRL DL_DPCH_InfoPerRL, powerOffsetOfTFCI_PO1 INTEGER (0..50), powerOffsetOfTPC_PO2 INTEGER (0..50), powerOffsetOfPILOT_PO3 INTEGER (0..50), dl_TxPower DL_TxPower, dl_TxPowerMax DL_TxPower, dl_TxPowerMin DL_TxPower }</pre>	

ASN.1 Type Definition	
Type Name	DL_TxPower_PCPICH
Comment	Absolute Tx Power of PCPICH
Type Definition	
INTEGER (-60..-30)	

ASN.1 Type Definition	
Type Name	DL_TxPower
Comment	Relative Tx Power for PCPICH
Type Definition	
INTEGER (-35..+15)	

ASN.1 Type Definition	
Type Name	SCCPCHSlotFormat
Comment	Reference to TS25.211
Type Definition	
INTEGER (0..17)	

ASN.1 Type Definition	
Type Name	UL_DPCCHSlotFormat
Comment	Reference to TS25.211
Type Definition	
INTEGER (0..5)	

7.3.2.2.9 CPHY_Sync

ASN.1 ASP Type Definition	
Type Name	CPHY_Sync_IND
PCO Type	CSAP
Comment	To indicate that physical channel synchronization (in FDD mode, sync with DPCCCH) has been achieved.
Type Definition	
SEQUENCE	{ cellId INTEGER(0..15), routingInfo RoutingInfo }

7.3.2.2.10 CPHY_TrCH_Config

ASN.1 ASP Type Definition	
Type Name	CPHY_TrCH_Config_CNF
PCO Type	CSAP
Comment	To confirm to configure the transport channel
Type Definition	
SEQUENCE	{ cellId INTEGER(0..15), routingInfo RoutingInfo }

ASN.1 ASP Type Definition	
Type Name	CPHY_TrCH_Config_REQ
PCO Type	CSAP
Comment	To request to configure the transport channel
Type Definition	
SEQUENCE	{ cellId INTEGER(0..15), routingInfo RoutingInfo, ratType RatType, configMessage CphyTrchConfigReq }

ASN.1 Type Definition	
Type Name	CphyTrchConfigReq
Comment	To request to configure the transport channel
Type Definition	
SEQUENCE	{
ulconnectedTrCHList	SEQUENCE (SIZE (0..maxTrCH)) OF SEQUENCE {
trchid	TransportChannelIdentity,
ul_TransportChannelType	SS_UL_TransportChannel_Type,
transportChannelInfo	CHOICE {
ul_CommonTrCHInfo	CommonTransChTFS,
ul_DedTrCHInfo	DedicatedTransChTFS } ,
} OPTIONAL,	
ulctfcList	SEQUENCE (SIZE (0..maxTFC)) OF SEQUENCE {
ctfc	INTEGER (0..1023),
gainFactorInformation	PowerOffsetInformation } OPTIONAL,
dlconnectedTrCHList	SEQUENCE (SIZE (0..maxTrCH)) OF SEQUENCE {
trchid	TransportChannelIdentity,
dl_TransportChannelType	SS_DL_TransportChannel_Type,
transportChannelInfo	CHOICE {
dl_CommonTrCHInfo	CommonTransChTFS,
dl_DedTrCHInfo	DedicatedTransChTFS } ,
} OPTIONAL,	
dlctfcList	SEQUENCE (SIZE (0..maxTFC)) OF SEQUENCE {
ctfc	INTEGER (0..1023) } OPTIONAL
}	

ASN.1 Type Definition	
Type Name	RoutingInfo
Comment	To route between each channels.
Type Definition	
CHOICE	{
physicalChannelIdentity	INTEGER {0..31},
transportChannelIdentity	TransportChannelIdentity,
logicalChannelIdentity	LogicalChannelIdentity,
rB_Identity	INTEGER {-31..32},
cn-DomainIdentity	CN-DomainIdentity
}	

ASN.1 Type Definition	
Type Name	RatType
Comment	To select route between each channels.
Type Definition	
ENUMERATED	{
fdd, tdd	
}	

7.3.2.2.11 [VoidCPHY_TrCH_Release](#)

ASN.1 ASP Type Definition	
Type Name	CPHY_TrCH_Release_CNF
PCO Type	CSAP
Comment	To confirm to release the Radio Link
Type Definition	
SEQUENCE	{
cellId	INTEGER(0..15),
routingInfo	RoutingInfo
}	

ASN.1 ASP Type Definition	
Type Name	CPHY_TrCH_Release_REQ
PCO Type	CSAP
Comment	To request to release the Radio Link
Type Definition	
<pre>SEQUENCE { cellId INTEGER(0..15), routingInfo RoutingInfo }</pre>	

7.3.2.2.12 CMAC_Ciphering_Activate

ASN.1 ASP Type Definition	
Type Name	CMAC_Ciphering_Activate_CNF
PCO Type	CSAP
Comment	To confirm to activate or inactivate the ciphering
Type Definition	
<pre>SEQUENCE { cellId INTEGER(0..15), routingInfo RoutingInfo }</pre>	

ASN.1 ASP Type Definition	
Type Name	CMAC_Ciphering_Activate_REQ
PCO Type	CSAP
Comment	To request to start, restart or stop downlink ciphering or uplink deciphering . The physicalChannelIdentity of DPCH applies to routingInfo.
Type Definition	
<pre>SEQUENCE { cellId INTEGER(0..15), routingInfo RoutingInfo, ratType RatType, cipheringModeInfo CipheringModeInfo }</pre>	

7.3.2.2.13 CMAC_Config

ASN.1 ASP Type Definition	
Type Name	CMAC_Config_CNF
PCO Type	CSAP
Comment	For MAC emulator to report that a previous attempt to setup, reconfigure or release a logical channel is successful.
Type Definition	
<pre>SEQUENCE { cellId INTEGER(0..15), routingInfo RoutingInfo }</pre>	

ASN.1 ASP Type Definition	
Type Name	CMAC_Config_REQ
PCO Type	CSAP
Comment	To request to configure MAC entity
Type Definition	
SEQUENCE	{
cellId	INTEGER(0..15),
routingInfo	RoutingInfo,
ratType	RatType,
configMessage	CmacConfigReq
}	

ASN.1 Type Definition	
Type Name	CmacConfigReq
Comment	To request to configure MAC
Type Definition	
SEQUENCE	{
uE_Info	UE_Info,
trCHInfo	TrCHInfo,
trCH_LogCHMapping	TrCH_LogCHMappingList1
-- RACHTransmissionCtrolElements	TBD,
-- CPCHTransmissionControlElements	TBD
}	

ASN.1 Type Definition	
Type Name	UE_Info
Comment	
Type Definition	
SEQUENCE	{
u_RNTI	
SEQUENCE	{
srnc_Identity	BIT STRING (SIZE (12)),
s_RNTI	BIT STRING (SIZE (20))
}	U_RNTI OPTIONAL,
c_RNTI	BIT STRING (SIZE (16))
C_RNTI	OPTIONAL
}	

ASN.1 Type Definition	
Type Name	TrCH_LogCHMappingList1
Comment	maxulTrCH = maxdlTrCH = 16
Type Definition	
SEQUENCE	{
ulconnectedTrCHList	SEQUENCE (SIZE (1..maxulTrCH)) OF SEQUENCE {
trchid	TransportChannelIdentity,
trCH_LogCHMappingList	TrCH_LogCHMappingList
}	OPTIONAL,
dlconnectedTrCHList	SEQUENCE (SIZE (1..maxdlTrCH)) OF SEQUENCE {
trchid	TransportChannelIdentity,
trCH_LogCHMappingList	TrCH_LogCHMappingList
}	OPTIONAL
}	

ASN.1 Type Definition	
Type Name	TrCH_LogCHMappingList
Comment	maxLogCHperTrCH = 8
Type Definition	
SEQUENCE	(SIZE (1..maxLogCHperTrCH)) OF TrCH_LogicalChannelMapping

ASN.1 Type Definition	
Type Name	TrCHInfo
Comment	
Type Definition	
SEQUENCE	{
ulconnectedTrCHList	SEQUENCE (SIZE (1..maxulTrCH)) OF SEQUENCE {
trchid	TransportChannelIdentity,
transportChannelInfo	CHOICE {
ul_CommonTrCHInfo	CommonTransChTFS,
ul_DedTrCHInfo	DedicatedTransChTFS},
	} OPTIONAL,
ulctfcList	SEQUENCE (SIZE (0..maxTFC)) OF SEQUENCE {
ctfc	INTEGER (0..1023),
	} OPTIONAL,
dlconnectedTrCHList	SEQUENCE (SIZE (1..maxdlTrCH)) OF SEQUENCE {
trchid	TransportChannelIdentity,
transportChannelInfo	CHOICE {
dl_CommonTrCHInfo	CommonTransChTFS,
dl_DedTrCHInfo	DedicatedTransChTFS},
	} OPTIONAL,
dlctfcList	SEQUENCE (SIZE (0..maxTFC)) OF SEQUENCE {
ctfc	INTEGER (0..1023)
	} OPTIONAL
	}

ASN.1 Type Definition	
Type Name	TrCH_LogicalChannelMapping
Comment	
Type Definition	
SEQUENCE	{
CHOICE	{
ul_LogicalChannelMapping	SS_UL_LogicalChannel_Mapping,
dl_LogicalChannelMapping	SS_DL_LogicalChannel_Mapping
},	
rB_Identity	<u>INTEGER</u> {-31..32},RB_Identity,
cn-DomainIdentity	CN-DomainIdentity OPTIONAL
	}

ASN.1 Type Definition	
Type Name	SS_UL_LogicalChannel_Mapping
Comment	
Type Definition	
SEQUENCE	{
macHeaderManipulation	MAC_HeaderManipulation,
ul_TransportChannelType	SS_UL_TransportChannel_Type,
logicalChannelIdentity	LogicalChannelIdentity,
logicalChannelType	LogicalChannelType OPTIONAL
	}

ASN.1 Type Definition	
Type Name	SS_DL_LogicalChannel_Mapping
Comment	
Type Definition	
SEQUENCE	{
macHeaderManipulation	MAC_HeaderManipulation,
dlTransportChannelType	SS_DL_TransportChannel_Type,
logicalChannelIdentity	LogicalChannelIdentity,
logicalChannelType	LogicalChannelType OPTIONAL,
mac_LogicalChannelPriority	MAC_LogicalChannelPriority OPTIONAL
	}

ASN.1 Type Definition	
Type Name	SS_UL_TransportChannel_Type
Comment	
Type Definition	
<pre> ENUMERATED { dch, rach, cpch, usch } </pre>	

ASN.1 Type Definition	
Type Name	MAC_LogicalChannelPriority
Comment	
Type Definition	
<pre> INTEGER (1..8) </pre>	

ASN.1 Type Definition	
Type Name	SS_DL_TransportChannel_Type
Comment	
Type Definition	
<pre> ENUMERATED { dch, fach, bch, pch, dsch } </pre>	

ASN.1 Type Definition	
Type Name	<u>LogicalChannelType</u>
Comment	
Type Definition	
<pre> ENUMERATED { <u>BCCH</u>, <u>PCCH</u>, <u>CCCH</u>, <u>CTCH</u>, <u>DCCH</u>, <u>DTCH</u>, <u>SHCCH</u> } </pre>	

ASN.1 Type Definition	
Type Name	<u>MAC_HeaderManipulation</u>
Comment	
Type Definition	
<pre> ENUMERATED { <u>NormalMacHeader</u>, <u>OmitMacHeader</u> } </pre>	

7.3.2.2.14 CMAC_PAGING_Config

ASN.1 ASP Type Definition	
Type Name	CMAC_PAGING_Config_CNF
PCO Type	CSAP
Comment	To confirm to setup the paging message
Type Definition	
SEQUENCE	{ cellId INTEGER(0..15), routingInfo RoutingInfo }

ASN.1 ASP Type Definition	
Type Name	CMAC_PAGING_Config_REQ
PCO Type	CSAP
Comment	To request MAC layer to send the Paging message on the specified configuration.
Type Definition	
SEQUENCE	{ cellId INTEGER(0..15), routingInfo RoutingInfo, ratType RatType, configMessage CmacPagingConfigReq }

ASN.1 Type Definition	
Type Name	CmacPagingConfigReq
Comment	
Type Definition	
SEQUENCE	{ pI_BitMapInfo CHOICE { e18 BIT STRING (SIZE (18)), e36 BIT STRING (SIZE (36)), e72 BIT STRING (SIZE (72)), e144 BIT STRING (SIZE (144)) }, dRX_CycleLength INTEGER {2..12}, iMSI SEQUENCE (SIZE (6..15)) OF Digit, t_pich_T_sccpch BOOLEAN -- T_pich>T_sccpch then FALSE }

7.3.2.2.15 CMAC_SecurityMode_Config

ASN.1 ASP Type Definition	
Type Name	CMAC_SecurityMode_Config_CNF
PCO Type	CSAP
Comment	To confirm to configure the MAC security mode
Type Definition	
SEQUENCE	{ cellId INTEGER(0..15) }

ASN.1 ASP Type Definition	
Type Name	CMAC_SecurityMode_Config_REQ
PCO Type	CSAP
Comment	To request to configure the MAC security mode
Type Definition	
SEQUENCE {	
cellId	INTEGER(0..15),
macCipheringInfo	SecurityInfo
}	

7.3.2.2.16 CMAC_SequenceNumber

ASN.1 ASP Type Definition	
Type Name	CMAC_Sequence_Number_CNF
PCO Type	CSAP
Comment	To return the requested counter sequence number on MAC-d DCH. The physicalChannelIdentity of DPCH applies to routingInfo.
Type Definition	
SEQUENCE {	
cellId	INTEGER(0..15),
routingInfo	RoutingInfo,
count_C_MSB_UL	COUNT_C_MSB ,
count_C_MSB_DL	COUNT_C_MSB
}	

ASN.1 ASP Type Definition	
Type Name	CMAC_SequenceNumber_REQ
PCO Type	CSAP
Comment	To request the MAC layer to return current counter sequence numbers. The physicalChannelIdentity of DPCH applies to routingInfo.
Type Definition	
SEQUENCE {	
cellId	INTEGER(0..15),
routingInfo	RoutingInfo
}	

7.3.2.2.17 CMAC_SYSINFO_Config

ASN.1 ASP Type Definition	
Type Name	CMAC_SYSINFO_Config_CNF
PCO Type	CSAP
Comment	To confirm to setup the system information block
Type Definition	
SEQUENCE {	
cellId	INTEGER(0..15),
routingInfo	RoutingInfo
}	

ASN.1 ASP Type Definition	
Type Name	CMAC_SYSINFO_Config_REQ
PCO Type	CSAP
Comment	To request MAC layer to send the BCCH message on the specified configuration.
Type Definition	
SEQUENCE {	
cellId	INTEGER(0..15),
routingInfo	RoutingInfo,
ratType	RatType,
configMessage	CmacSysinfoConfigReq
}	

ASN.1 Type Definition	
Type Name	CmacSysinfoConfigReq
Comment	
Type Definition	
SEQUENCE {	
sib_TypeSIM_ID	INTEGER {0..255}SIB_Type,
segmentIndex	SegmentIndex,
sgSG_REP	INTEGER (2..12),
sgSG_POS	INTEGER {0..4096},
bcchBCCH_MmodificationTime	BCCH_ModificationTimeINTEGER {0..4096}OPTIONAL
}	

7.3.2.2.18 CRLC_Ciphering_Activate

ASN.1 ASP Type Definition	
Type Name	CRLC_Ciphering_Activate_REQ
PCO Type	CSAP
Comment	To request to start, restart or stop <u>downlink ciphering</u> or <u>uplink deciphering</u> . RB-identity shall apply to routingInfo . Each call of the ASP includes one RLC SN in rb-DL-CiphActivationTimeInfo for the corresponding rb-identity.
Type Definition	
SEQUENCE {	
cellId	INTEGER(0..15),
routingInfo	RoutingInfo,
ratType	RatType,
ciphActivationeringModeInfo	CiphActivationeringModeInfo
}	

ASN.1 Type Definition	
Type Name	CiphActivationInfo
Comment	DL or UL iphering activation info
Type Definition	
CHOICE {	
cipheringModeInfo	CipheringModeInfo,
rb_UL_CiphActivationTimeInfo	RB_ActivationTimeInfoList
}	

ASN.1 ASP Type Definition	
Type Name	CRLC_Ciphering_Activate_CNF
PCO Type	CSAP
Comment	To confirm to activate or inactivate the ciphering
Type Definition	
SEQUENCE {	
cellId	INTEGER(0..15),
routingInfo	RoutingInfo
}	

7.3.2.2.19 CRLC_Config

ASN.1 ASP Type Definition	
Type Name	CRLC_Config_CNF
PCO Type	CSAP
Comment	For RLC emulator to confirm that a previous attempt to establish, re_configure or release a radio bearer has been successful.
Type Definition	
SEQUENCE {	
cellId	INTEGER(0..15),
routingInfo	RoutingInfo
}	

ASN.1 ASP Type Definition	
Type Name	CRLC_Config_REQ
PCO Type	CSAP
Comment	To request to setup, reconfigure or release RLC entity
Type Definition	
SEQUENCE {	
cellId	INTEGER(0..15),
routingInfo	RoutingInfo,
ratType	RatType,
configMessage	CrlcConfigReq
}	

ASN.1 Type Definition	
Type Name	CrlcConfigReq
Comment	To request to setup, re_configure or release RLC entity
Type Definition	
CHOICE {	
setup	RBInfo,
reconfigure	RBInfo,
release	NULL
}	

ASN.1 Type Definition		
Type Name	RBInfo	
Comment		
Type Definition		
SEQUENCE (
pdcp_Info	PDCP_Info	OPTIONAL,
sS_rlc_Info	SS_RLC_Info	OPTIONAL,
rB_LogCH_Mapping	RB_LogCH_Mapping	
}		

ASN.1 Type Definition	
Type Name	RB_LogCH_Mapping
Comment	Provide mapping information between RB, logical channel and CN domain.
Type Definition	
<pre>SEQUENCE { uLogicalChannelIdentity LogicalChannelIdentity OPTIONAL, dLogicalChannelIdentity LogicalChannelIdentity OPTIONAL, logicalChannelType LogicalChannelType OPTIONAL, cn-DomainIdentity CN-DomainIdentity OPTIONAL }</pre>	

ASN.1 Type Definition	
Type Name	SS_RLCInfo
Comment	
Type Definition	
<pre>SEQUENCE { sS_ul_RLC_Mode DL_RLC_Mode OPTIONAL, sS_dl_RLC_Mode SS_DL_RLC_Mode OPTIONAL }</pre>	

ASN.1 Type Definition	
Type Name	SS_DL_RLC_Mode
Comment	
Type Definition	
<pre>SEQUENCE { dl_PayloadSize PayloadSize OPTIONAL, dl_RLCModeInfo UL_RLC_Mode }</pre>	

ASN.1 Type Definition	
Type Name	PayloadSize
Comment	
Type Definition	
<pre>INTEGER (0..4992)</pre>	

7.3.2.2.20 CRLC_Integrity_Activate

ASN.1 ASP Type Definition	
Type Name	CRLC_integrity_Activate_CNF
PCO Type	CSAP
Comment	To confirm to activate or inactivate the integrity protection
Type Definition	
<pre>SEQUENCE { cellId INTEGER(0..15) }</pre>	

ASN.1 ASP Type Definition	
Type Name	CRLC_Integrity_Activate_REQ
PCO Type	CSAP
Comment	To request to start or to modify the the downlink or uplink integrity protection. The ASP shall be called before send SECURITY MODE COMMAND. It activates the integrity on all SRBs in DL. Not to call the ASP if wishing to switch off the integrity in the test case.
Type Definition	
<pre>SEQUENCE { cellId INTEGER(0..15), integrityActivationInfo IntegrityActivationInfo }</pre>	

ASN.1 Type Definition	
Type Name	IntegrityActivationInfo
Comment	DL or UL integrity activation info
Type Definition	
<pre>CHOICE { integrityProtectionModeInfo IntegrityProtectionModeInfo, ul-IntegProtActivationInfo IntegrityProtActivationInfo }</pre>	

7.3.2.2.21 CRLC_Integrity_Failure

ASN.1 ASP Type Definition	
Type Name	CRLC_Integrity_Failure_IND
PCO Type	CSAP
Comment	RLC emulator reports the occurrences of a failure in integrity protection, i.e. reception of an integrity-protected RLC AM/UM SDU containing a non-matching X-MAC value compared to the desired.
Type Definition	
<pre>SEQUENCE { cellId INTEGER(0..15), routingInfo RoutingInfo, failureCause ENUMERATED { codeNotMatched(0) } -- the enumerated types of failure cause field is ffs }</pre>	

7.3.2.2.22 CRLC_Resume

ASN.1 ASP Type Definition	
Type Name	CRLC_Resume_CNF
PCO Type	CSAP
Comment	To confirm the resume request
Type Definition	
<pre>SEQUENCE { cellId INTEGER(0..15), routingInfo RoutingInfo }</pre>	

ASN.1 ASP Type Definition	
Type Name	CRLC_Resume_REQ
PCO Type	CSAP
Comment	To request to resume data transmission
Type Definition	
SEQUENCE {	
cellId	INTEGER(0..15),
routingInfo	RoutingInfo
}	

7.3.2.2.23 CRLC_SecurityMode_Config

ASN.1 ASP Type Definition	
Type Name	CRLC_SecurityMode_Config_CNF
PCO Type	CSAP
Comment	To confirm to configure the RLC security mode
Type Definition	
SEQUENCE {	
cellId	INTEGER(0..15)
}	

ASN.1 ASP Type Definition	
Type Name	CRLC_SecurityMode_Config_REQ
PCO Type	CSAP
Comment	To request to configure the RLC security mode
Type Definition	
SEQUENCE {	
cellId	INTEGER(0..15),
rlcSecurityInfo	SecurityInfo}
}	

ASN.1 Type Definition	
Type Name	SecurityInfo
Comment	The integrityKey is not applicable to MAC
Type Definition	
SEQUENCE {	
cn-DomainIdentity	CN-DomainIdentity,
cipherringKey	BITSTRING(128),
startValue	START_VALUE,
cipherringKey	BITSTRING(128) OPTIONAL,
integrityKey	BITSTRING(128) OPTIONAL,
gsmCipherringKey	BITSTRING(64) OPTIONAL
}	

7.3.2.2.24 CRLC_SequenceNumber

ASN.1 ASP Type Definition	
Type Name	CRLC_Sequence_Number_CNF
PCO Type	CSAP
Comment	To return the requested counter sequence number
Type Definition	
SEQUENCE {	
cellId	INTEGER(0..15),
routingInfo	RoutingInfo,
count_C_MSB_UL	COUNT_C_MSB,
count_C_MSB_DL	COUNT_C_MSB
}	

ASN.1 ASP Type Definition	
Type Name	CRLC_SequenceNumber_REQ
PCO Type	CSAP
Comment	To request the RLC layer to return current counter sequence numbers
Type Definition	
<pre>SEQUENCE { cellId INTEGER(0..15), routingInfo RoutingInfo }</pre>	

7.3.2.2.25 CRLC_Status

ASN.1 ASP Type Definition	
Type Name	CRLC_Status_IND
PCO Type	CSAP
Comment	To report the occurrence of certain events to RRC. Note: the possible event types to be defined for this ASP is FFS.
Type Definition	
<pre>SEQUENCE { cellId INTEGER(0..15), routingInfo RoutingInfo, ratType RatType, statusInd CrlcStatusInd }</pre>	

ASN.1 Type Definition	
Type Name	CrlcStatusInd
Comment	
Type Definition	
<pre>ENUMERATED { DataLinkFailure, MaxRESET, SDUdiscarded -- __ More event types are to be added here }</pre>	

7.3.2.2.26 CRLC_Suspend

ASN.1 ASP Type Definition	
Type Name	CRLC_Suspend_CNF
PCO Type	CSAP
Comment	To confirm to suspend data transmission
Type Definition	
<pre>SEQUENCE { cellId INTEGER(0..15), routingInfo RoutingInfo, sn RLC_SequenceNumber }</pre>	

ASN.1 ASP Type Definition	
Type Name	CRLC_Suspend_REQ
PCO Type	CSAP
Comment	To request to suspend data transmission
Type Definition	
SEQUENCE {	
cellId	INTEGER(0..15),
routingInfo	RoutingInfo,
n	RLC_SequenceNumber
}	

7.3.2.2.27 RLC_TR_DATA

ASN.1 ASP Type Definition	
Type Name	RLC_TR_DATA_REQ
PCO Type	CSAPDSAP
Comment	To request to transmit DATA using transparent mode.
Type Definition	
SEQUENCE {	
cellId	INTEGER(0..15),
routingInfo	RoutingInfo,
tM_Message	Message
}	

ASN.1 ASP Type Definition	
Type Name	RLC_TR_DATA_IND
PCO Type	DSAP
Comment	To indicate to receive DATA using transparent mode.
Type Definition	
SEQUENCE {	
cellId	INTEGER(0..15),
routingInfo	RoutingInfo,
tM_Message	Message
}	

7.3.2.2.28 RLC_AM_DATA

ASN.1 ASP Type Definition	
Type Name	RLC_AM_DATA_REQ
PCO Type	DSAP
Comment	To request to transmit DATA using acknowledged mode.
Type Definition	
SEQUENCE {	
cCellId	INTEGER (0..15),
rRoutingInfo	RoutingInfo,
confirmationRequest	AmConfirmationRequest ,
aM_Message	Message,
m	INTEGER(0..4095) OPTIONAL
}	

ASN.1 Type Definition	
Type Name	AmConfirmationRequest
Comment	If the noConfirmationRequested option is used, then an RLC AM DATA CNF is not expected from the RLC AM entity. If the confirmationRequested option is used, then the RLC AM entity is being requested to provide an RLC AM DATA CNF primitive containing the same Mui value.
Type Definition	
CHOICE {	
noConfirmationRequest	NULL,
confirmationRequested	Mui
}	

ASN.1 Type Definition	
Type Name	Mui
Comment	
Type Definition	
INTEGER {0..4095}	

ASN.1 ASP Type Definition	
Type Name	RLC_AM_DATA_IND
PCO Type	DSAP
Comment	To indicate to receive DATA using acknowledged mode.
Type Definition	
SEQUENCE {	
cellId	INTEGER(0..15),
routingInfo	RoutingInfo,
aM_Message	Message,
integrityResult	IntegrityResult OPTIONAL,
aM_Message	Message
}	

ASN.1 Type Definition	
Type Name	IntegrityResult
Comment	
Type Definition	
CHOICE {	
integrityNotUsed	NULL,
integrityUsed	IntegrityStatus
}	

ASN.1 Type Definition	
Type Name	IntegrityStatusResult
Comment	
Type Definition	
ENUMERATED {	
i_pass(0),	i_fail(1)
}	

ASN.1 ASP Type Definition	
Type Name	RLC_AM_DATA_CNF
PCO Type	DSAP
Comment	For RLC emulator to report to the upper layer that a previously transmitted SDU has been acknowledged correctly by the UE
Type Definition	
<pre>SEQUENCE { cellId INTEGER(0..15), routingInfo RoutingInfo, mui INTEGER(0..4095)MUI }</pre>	

ASN.1 PDU Type Definition	
Type Name	Message
PCO Type	DSAP
Comment	
Type Definition	
<pre>CHOICE { dL_DCCH_Message DL_DCCH_Message, uL_DCCH_Message UL_DCCH_Message, dL_CCCH_Message DL_CCCH_Message, uL_CCCH_Message UL_CCCH_Message, pCCH_Message PCCH_Message, dL_SHCCH_Message DL_SHCCH_Message, uL_SHCCH_Message UL_SHCCH_Message, bCCH_FACH_Message BCCH_FACH_Message, bCCH_BCH_Message BCCH_BCH_Message }</pre>	

7.3.2.2.29 RLC_UM_DATA

ASN.1 ASP Type Definition	
Type Name	RLC_UM_DATA_REQ
PCO Type	DSAP
Comment	To request to transmit DATA using unacknowledged mode.
Type Definition	
<pre>SEQUENCE { cellId INTEGER(0..15), routingInfo RoutingInfo, uM_Message Message }</pre>	

ASN.1 ASP Type Definition	
Type Name	RLC_UM_DATA_IND
PCO Type	DSAP
Comment	To indicate to receive DATA using unacknowledged mode.
Type Definition	
<pre>SEQUENCE { cellId INTEGER(0..15), routingInfo RoutingInfo, uM_Message Message, integrityResult IntegrityResult OPTIONAL, uM_Message Message }</pre>	

7.3.3 TTCN Primitives for RLC and RB tests

The table below shows the primitives that are used for RLC ~~and RB~~ and RRC invalid PER encoding tests, these primitives are defined in TTCN tabular form.

Table 17: Primitives for RLC and RB tests

Primitive	Parameters	Use
RLC_TR_TestDataReq	Cell identity Routing info Data (Meta type PDU)	The ASP is used to request the transmission of unstructured data using transparent mode in the downlink direction
RLC_TR_TestDataInd	Cell identity Routing info Data (Meta type PDU)	The ASP is used to indicate the reception of unstructured data using transparent mode in the uplink direction
RLC_UM_TestDataReq	Cell identity Routing info Data (Meta type PDU)	The ASP is used to request the transmission of unstructured data using unacknowledged mode in the downlink direction
RLC_UM_TestDataInd	Cell identity Routing info Data (Meta type PDU)	The ASP is used to indicate the reception of unstructured data using unacknowledged mode in the uplink direction
RLC_AM_TestDataReq	Cell identity Routing info Data (Meta type PDU)	The ASP is used to request the transmission of unstructured data using acknowledged mode in the downlink direction
RLC_AM_TestDataInd	Cell identity Routing info Data (Meta type PDU)	The ASP is used to indicate the reception of unstructured data using acknowledged mode in the uplink direction

The TTCN tabular format applies to the primitive definitions.

8 Design Consideration

8.1 Channel mapping

The figure 8 below shows the channel type mapping that is used for the configuration of the SS.

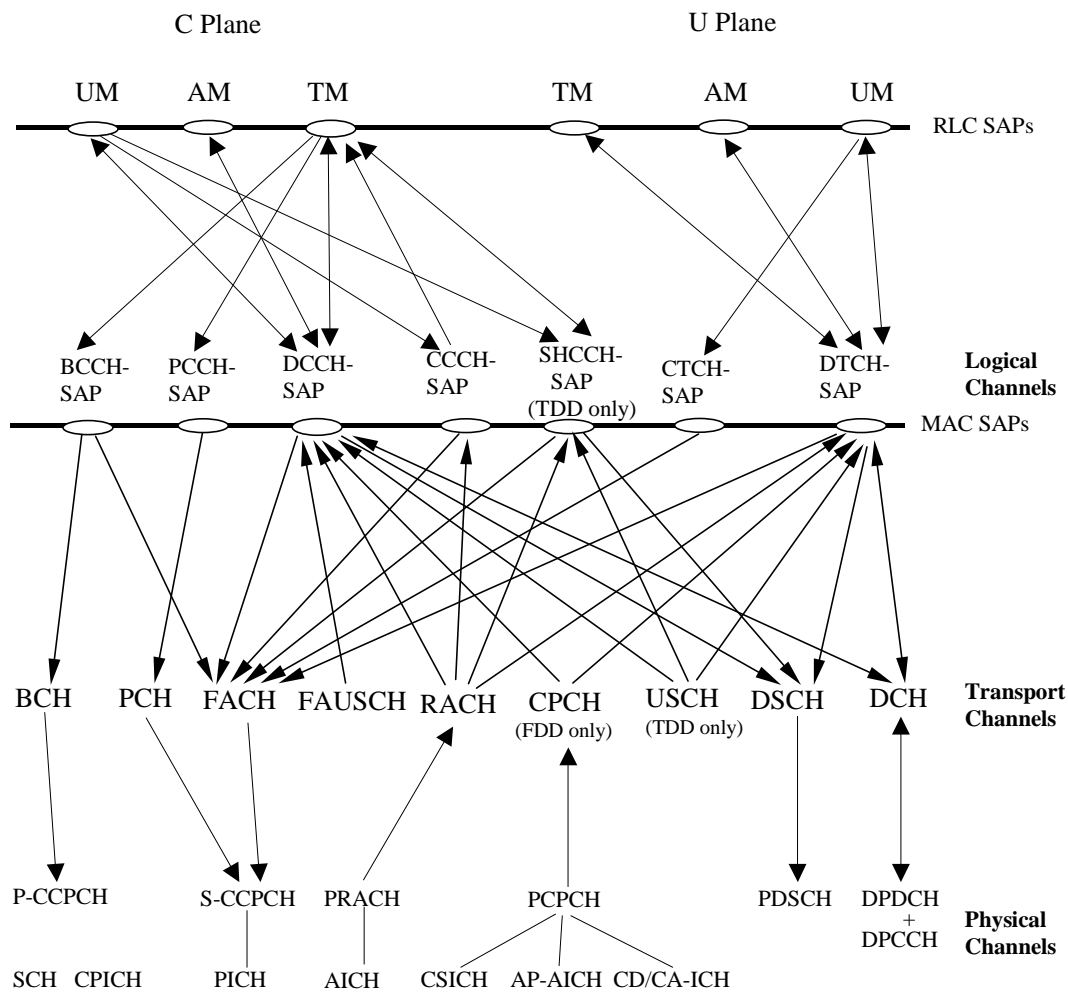

Figure 8: Channel mapping in SS

8.2 Channel and RB identity

The TTCN addresses the TTCN tester by using a channel identifier:

- Either Physical channel identifier (PhyCh id), or
- Transport channel identifier (TrCh id), or
- Radio bearer identifier (RB id).

The selected channel identifier identifies uniquely

- A channel within a cell,
- A total path of the address in the lower layers concerned.

Having taken out the cell id and PCO id (AM, UM and TM), a complete address, as RoutingInfo in the RRC ASP definition, should have at least five fields, CN domain id, RB id, LogCH id, TrCH id and PhyCH id. For simplified application of CHOICE of the routing information, a TTCN writer must carefully follow a number of rules assigning the channel identifiers.

General requirements:

A structured scheme of planning all channel identifiers assigned.

The scheme shall meet the requirements for all test cases in 34.123-1 including TDD channels.

The scheme can apply to all radio bearer configurations in 34.108, 6.10.

A clear multiplex mapping between a PhyCH id to TrCH ids and a TrCH id to LogCH ids, RB ids is needed.

Requirements on identification of RB in a test case:

Unique identification of the individual SRBs

Unique identification of the individual sub-flows of a RABs in CS and PS domain,

An assigned RB id can represent UL and DL.

Requirements on identification of Logical Channel in a test case:

It is an instance number of the individual logical channel and uniquely identifies among all the Logical Channel mapped onto a Transport Channel.

Requirements on identification of Transport Channel in a test case:

Unique identification of the individual Transport Channel

Assign different identities for UL and DL of a same Transport Channel type

The order of the Transport Channel id assigned in a cell shall follow the TFCS definitions in the 34.108, 6.10. For example, Transport Channel ids are assigned in the ascending order for (RABsubflow#1, RABsubflow#2, RABsubflow#3, 64kRAB, DCCH).

Requirements on identification of Physical Channel in a test case:

Unique identification of the individual Physical Channel

Assign different identities for UL and DL of a same Physical Channel type

Each S-CCPCH or PRACH has a unique identifier

For 2Mbps PS data (in case of demux of a Transport Channel), three DPCH or three DPDCH are needed for high-speed data. A single Physical Channel id is assigned to a bundle of the three physical channels.

The table 16 shows which type of channel identity is chosen for the individual primitives. In the table, the ASN.1 primitives use a CHOICE type for channel identity, while TTCN primitives use an explicit channel identity.

Table 16: Primitives and the associated channel identity type

Primitive name	Channel Identity
	ASN.1 Primitives
CPHY_Cell_Config_CNF	No Routing Info Field Present
CPHY_Cell_Config_REQ	No Routing Info Field Present
<u>CPHY_Cell_Ini_CNF</u>	<u>No Routing Info Field Present</u>
<u>CPHY_Cell_Ini_REQ</u>	<u>No Routing Info Field Present</u>
CPHY_Cell_TxPower_Modify_CNF	No Routing Info Field Present
CPHY_Cell_TxPower_Modify_REQ	No Routing Info Field Present
<u>CPHY_Commit_CNF</u>	<u>Physical Channel Identity</u>
CPHY_Commit_REQ	Physical Channel Identity
CPHY_Frame_Number_CNF	Physical Channel Identity
CPHY_Frame_Number_REQ	Physical Channel Identity
CPHY_Out_of_Sync_IND	Physical Channel Identity
CPHY_RL_Modify_CNF	Physical Channel Identity
CPHY_RL_Modify_REQ	Physical Channel Identity
CPHY_RL_Release_CNF	Physical Channel Identity
CPHY_RL_Release_REQ	Physical Channel Identity
CPHY_RL_Setup_CNF	Physical Channel Identity
CPHY_RL_Setup_REQ	Physical Channel Identity
CPHY_Sync_IND	Physical Channel Identity
CPHY_TrCH_Config_CNF	Physical Channel Identity
CPHY_TrCH_Config_REQ	Physical Channel Identity
<u>CPHY_TrCH_Release_CNF</u>	<u>Physical Channel Identity</u>
<u>CPHY_TrCH_Release_REQ</u>	<u>Physical Channel Identity</u>
CMAC_Ciphering_Activate_CNF	Physical Channel Identity of DPCH
CMAC_Ciphering_Activate_REQ	Physical Channel Identity of DPCH
CMAC_Config_CNF	Physical Channel Identity
CMAC_Config_REQ	Physical Channel Identity
CMAC_PAGING_Config_CNF	Physical Channel Identity
CMAC_PAGING_Config_REQ	Physical Channel Identity
CMAC_SecurityMode_Config_CNF	No Routing Info Field Present (applies to all RB Ids)
CMAC_SequenceNumber_CNF	Physical Channel Identity
CMAC_SequenceNumber_REQ	Physical Channel Identity
CMAC_SYSINFO_Config_CNF	RB Identity
CMAC_SYSINFO_Config_REQ	RB Identity
CRLC_Ciphering_Activate_CNF	<u>No Routing Info Field Present (applies to all RB Ids)</u> <u>RB Identity</u>
CRLC_Ciphering_Activate_REQ	<u>No Routing Info Field Present (applies to all RB Ids)</u> <u>RB Identity</u>
CRLC_Config_CNF	RB Identity
CRLC_Config_REQ	RB Identity
CRLC_Integrity_Activate_CNF	No Routing Info Field Present (applies to all RB Ids)
CRLC_Integrity_Activate_REQ	No Routing Info Field Present (applies to all RB Ids)
CRLC_Integrity_Failure_IND	RB Identity
CRLC_Resume_CNF	RB Identity (applies to all suspended RB Ids)
CRLC_Resume_REQ	RB Identity (applies to all suspended RB Ids)
CRLC_SecurityMode_Config_CNF	No Routing Info Field Present (applies to all RB Ids)
CRLC_SecurityMode_Config_REQ	No Routing Info Field Present (applies to all RB Ids)
CRLC_SequenceNumber_CNF	RB Identity
CRLC_SequenceNumber_REQ	RB Identity
CRLC_Status_IND	RB Identity
CRLC_Suspend_CNF	RB Identity
CRLC_Suspend_REQ	RB Identity
RLC_AM_DATA_CNF	RB Identity
RLC_AM_DATA_IND	RB Identity
RLC_AM_DATA_REQ	RB Identity
RLC_TR_DATA_IND	RB Identity
RLC_TR_DATA_REQ	RB Identity
RLC_UM_DATA_IND	RB Identity

RLC_UM_DATA_REQ	RB Identity
TTCN Primitives	
RLC_AM_TestDataInd	RB Identity
RLC_AM_TestDataReq	RB Identity
RLC_TR_TestDataInd	RB Identity
RLC_TR_TestDataReq	RB Identity
RLC_UM_TestDataInd	RB Identity
RLC_UM_TestDataReq	RB Identity

8.2.1 Physical Channels

Table 17: Physical channel identities

Type	Min. No.	Current Config.	Identities (value assigned)	Direction	Comment
P-CCPCH	1	1	tsc_P_CCPCH (4)	downlink	Primary Common Control Physical Channel. For Broadcasting System Information messages, using the Primary Scrambling Code for the Cell.
P-CPICH	1	1	tsc_P_CPICH (0)	downlink	Primary Common Pilot Channel using the Primary Scrambling Code for the Cell.
S-CPICH	1	FFS	tsc_S_CPICH (3)	downlink	Secondary Common Pilot Channel, used as the phase reference for some RF tests.
P-SCH	1	1	tsc_P_SCH (1)	downlink	Primary Synchronisation Channel
S-SCH	1	1	tsc_S_SCH (2)	downlink	Secondary Synchronisation Channel
S-CCPCH	2	1	tsc_S_CCPCH1 (5) tsc_S_CCPCH2 (10)	downlink	Secondary Common Control Physical Channel.
PICH	1	1	tsc_PICH1 (6)	downlink	To identify whether the UE should access the PCCH for Paging Messages.
AICH	1	1	tsc_AICH1 (7)	downlink	General Acquisition Indicator Channel, can be used for: - Acquisition Indicator Channel, for PRACH - Access Preamble Acquisition Indicator Channel (AP-ICH), for PCPCH - Collision-Detection/Channel-Assignment Indicator Channel (CD/CA-ICH), for PCPCH
DPCH	3	1	tsc_DL_DPCH1 (26) tsc_DL_DPCH2 (27)	downlink	Downlink Physical Data Channel. Layer 1 signalling is transmitted only on the first DPCH. This number is for the First Cell. Additional Cells may define a lower number which should be at least 1.
PDSCH	1	FFS		downlink	Physical Downlink Shared Channel.
DPDCH	1	1	tsc_UL_DPCH1 (20) tsc_UL_DPCH2 (21)	uplink	Uplink Dedicated Physical Channel. A single DPCH associated with all the DPDCHs used for Layer 1 signalling.
PRACH	2	1	tsc_PRACH1 (8) tsc_PRACH2 (9)	uplink	Physical Random Access Channel.
PCPCH	1	FFS		uplink	Physical Common Packet Channel.
CSICH	1	FFS		downlink	CPCH Status Indicator Channel

The Physical Channel values 20 to 25 are assigned to uplink DPCHs and the values 26 to 31 are assigned to downlink DPCHs,

8.2.2 Transport Channels

Table 18: Transport channel identities

Type	Min. No.	Current Config.	Identities (value assigned)	Direction	Comments
BCH	1	1	tsc_BCH1 (11)	downlink	
FACH	1	1	tsc_FACH1 (13) tsc_FACH2 (14)	downlink	
PCH	1	1	tsc_PCH1 (12)	downlink	
DCH	n	4	tsc_UL_DCH1 (1) tsc_UL_DCH2 (2) tsc_UL_DCH3 (3) tsc_UL_DCH4 (4) tsc_UL_DCH5 (5)	uplink	tsc_UL_DCH1 for RAB subflow#1, tsc_UL_DCH2 for RAB subflow#2, tsc_UL_DCH3 for RAB subflow#3, tsc_UL_DCH4 for future use, tsc_UL_DCH5 for SRB.
DCH	n	4	tsc_DL_DCH1 (6) tsc_DL_DCH2 (7) tsc_DL_DCH3 (8) tsc_DL_DCH4 (9) tsc_DL_DCH5 (10)	downlink	tsc_DL_DCH1 for RAB subflow#1, tsc_DL_DCH2 for RAB subflow#2, tsc_DL_DCH3 for RAB subflow#3, tsc_DL_DCH4 for future use, tsc_DL_DCH5 for SRB.
USCH	1	N/A	tsc_USCH1(20)	uplink	TDD only
DSCH	1	N/A	tsc_DSCH (19)	downlink	
RACH	2	1	tsc_RACH1 (15) tsc_RACH2 (16)	uplink	
CPCH	1	N/A	tsc_CPCH1(17)	uplink	
FAUSCH	N/A	N/A	tsc_FAUSCH1(18)	uplink	Not in Release 99

The TrCH values 20 – 29 are assigned to the TDD TrCH.

8.2.3 Logical Channels

The table below shows the logical channels identities

Table 19: Logical channel identities

Type	Min. No.	Current Config.	Identities (value assigned)	Direction	Comments
BCCH_BCH	1	1	tsc_BCCH1 (1)	downlink	
BCCH_FACH	1	1	tsc_BCCH5 (5)	downlink	
CCCH	1	1	tsc_CCCH6 (6)	downlink	
CCCH	1	1	tsc_CCCH5 (5)	uplink	
DCCH	4	4	tsc_DL_DCCH1 (1) tsc_DL_DCCH2 (2) tsc_DL_DCCH3 (3) tsc_DL_DCCH4 (4)	downlink	tsc_DL_DCCH1 for SRB1, tsc_DL_DCCH2 for SRB2, tsc_DL_DCCH3 for SRB3, tsc_DL_DCCH4 for SRB4
DCCH	4	4	tsc_UL_DCCH1 (1) tsc_UL_DCCH2 (2) tsc_UL_DCCH3 (3) tsc_UL_DCCH4 (4)	uplink	tsc_UL_DCCH1 for SRB1, tsc_UL_DCCH2 for SRB2, tsc_UL_DCCH3 for SRB3, tsc_UL_DCCH4 for SRB4
PCCH	1	1	tsc_PCCH1 (1)	downlink	
DTCH	n	4	tsc_UL_DTCH1 (7) tsc_UL_DTCH2 (8) tsc_UL_DTCH3 (9) tsc_UL_DTCH4 (10)	uplink	tsc_UL_DTCH1 for RAB subflow#1, tsc_UL_DTCH2 for RAB subflow#2, tsc_UL_DTCH3 for RAB subflow#3, tsc_UL_DTCH4 for future use
DTCH	n	4	tsc_DL_DTCH1 (7) tsc_DL_DTCH2 (8) tsc_DL_DTCH3 (9) tsc_DL_DTCH4 (10)	downlink	tsc_DL_DTCH1 for RAB subflow#1, tsc_DL_DTCH2 for RAB subflow#2, tsc_DL_DTCH3 for RAB subflow#3, tsc_DL_DTCH4 for future use
CTCH	1	1	tsc_CTCH (11)	downlink	

8.2.4 Radio bearers

Table 20: Radio bearer identities

Identities (value assigned)	Direction	Type	RLC mode	Service domain	Comments
tsc_RB_BCCH (-1)	downlink	SRB0	UM	NA	BCCH-BCH
tsc_RB_PCCH (-2)	downlink		TM		PCCH PCH
tsc_RB_BCCH_FA CH9 (9-3)	downlink		TM		BCCH FACH
tsc_RB0 (0)	uplink	SRB0	TM	CS or PS	The service domain for which the most recent security negotiation took place. CCCH
tsc_RB0 (0)	downlink	SRB0	UM	CS or PS	CCCH
tsc_RB1 (1)	uplink	SRB1	UM	CS or PS	DCCH
tsc_RB1 (1)	downlink	SRB1	UM	CS or PS	DCCH
tsc_RB2 (2)	uplink	SRB2	AM	CS or PS	DCCH
tsc_RB2 (2)	downlink	SRB2	AM	CS or PS	DCCH
tsc_RB3 (3)	uplink	SRB3	AM	CS or PS	DCCH
tsc_RB3 (3)	downlink	SRB3	AM	CS or PS	DCCH
tsc_RB4 (4)	uplink	SRB4	AM	CS or PS	DCCH
tsc_RB4 (4)	downlink	SRB4	AM	CS or PS	DCCH
tsc_RB5 (5)	uplink		TM		DCCH
tsc_RB5 (5)	downlink		TM		DCCH
tsc_RB10 (10)	uplink	RAB#1	TM	CS	
tsc_RB10 (10)	downlink	RAB#1	TM	CS	
tsc_RB11 (11)	uplink	RAB#2	TM	CS	
tsc_RB11 (11)	downlink	RAB#2	TM	CS	
tsc_RB12 (12)	uplink	RAB#3	TM	CS	
tsc_RB12 (12)	downlink	RAB#3	TM	CS	
tsc_RB20 (20)	uplink	RAB#1	AM	PS	
tsc_RB20 (20)	downlink	RAB#1	AM	PS	
tsc_RB30 (30)	downlink		UM		CTCH FACH

The RB values 0-5 are used for the signalling bearers. The values 10-15 are assigned to the CS RAB sub-flows. The values 20-25 are assigned to the PS RAB sub-flows. The value 30 is assigned to the CBSMS/BMC service.

8.3 Channels configurations

8.3.1 Configuration of Cell_FACH

The configuration is based on 34.108, 6.10.2.4.3.2.1.2 for downlink and 34.108, 6.10.2.4.4.1.1.1 without RAB/DTCH for uplink. The configuration is applied to the RRC tests related in the states CELL_FACH, CELL_PCH and URA_PCH. They need a minimum radio configuration for testing.

Table 21: Uplink configuration of Cell_FACH

RB Identity	tsc_RB0 (0)	tsc_RB1 (1)	tsc_RB2 (2)	tsc_RB3 (3)	tsc_RB4 (4)
LogCh Type	CCCH	DCCH	DCCH	DCCH	DCCH
LogCh Identity	tsc_CCCH5 (5)	tsc_UL_DCCH1 (1)	tsc_UL_DCCH2 (2)	tsc_UL_DCCH3 (3)	tsc_UL_DCCH4 (4)
RLC mode	TM	UM	AM	AM	AM
TrCH Type	RACH				
TrCH identity	tsc_RACH1 (15)				
PhyCh Type	PRACH				
PhyCH identity	tsc_PRACH1 (8)				

Table 22: Downlink configuration of Cell_FACH

RB Identity	tsc_RB0 (0)	tsc_RB1 (1)	tsc_RB2 (2)	tsc_RB3 (3)	tsc_RB4 (4)	tsc_RB9 (9-3)	tsc_RB_PCC H (7-2)
LogCh Type	CCCH	DCCH	DCCH	DCCH	DCCH	BCCH	PCCH
LogCh Identity	tsc_CCCH6 (6)	tsc_DL_DCCH1 (1)	tsc_DL_DCCH2 (2)	tsc_DL_DCCH3 (3)	tsc_DL_DCCH4 (4)	tsc_BCCH5 (5)	tsc_PCCH1 (1)
RLC mode	UM	UM	AM	AM	AM	TM	TM
MAC priority	1	2	3	4	5	6	1
TrCH Type	FACH						PCH
TrCH identity	tsc_FACH2 (14)						tsc_PCH1 (13)
PhyCh Type	Secondary CCPCH						
PhyCH identity	tsc_S_CCPCH1 (5)						

8.3.2 Configuration of Cell_DCH_StandAloneSRB

The configuration is based on 34.108, 6.10.2.4.1.2. The RB0/UM-CCCH is referred to 34.108, 6.10.2.4.3.2.1.2 and RB0/TM-CCCH is referred to 34.108, 6.10.2.4.4.1.1.1. The configuration is applied to the RRC and NAS signalling tests in the DCH state without RAB.

Table 23: Uplink configuration of Cell_DCH_StandAloneSRB

RB Identity	tsc_RB1 (1)	tsc_RB2 (2)	tsc_RB3 (3)	tsc_RB4 (4)	tsc_RB0 (0)
LogCh Type	DCCH	DCCH	DCCH	DCCH	CCCH
LogCh Identity	tsc_UL_DCCH1 (1)	tsc_UL_DCCH2 (2)	tsc_UL_DCCH3 (3)	tsc_UL_DCCH4 (4)	tsc_CCCH5 (5)
RLC mode	UM	AM	AM	AM	TM
TrCH Type	DCH				RACH
TrCH identity	tsc_UL_DCH5 (5)				tsc_RACH1 (15)
PhyCh Type	DPDCH				PRACH
PhyCH identity	tsc_UL_DPCH1 (20)				tsc_PRACH1 (8)

Table 24: Downlink configuration of Cell_DCH_StandAloneSRB

RB Identity	tsc_RB1 (1)	tsc_RB2 (2)	tsc_RB3 (3)	tsc_RB4 (4)	tsc_RB0 (0)	tsc_RB_PCCH (7-2)
LogCh Type	DCCH	DCCH	DCCH	DCCH	CCCH	PCCH
LogCh Identity	tsc_DL_DCCH1 (1)	tsc_DL_DCCH2 (2)	tsc_DL_DCCH3 (3)	tsc_DL_DCCH4 (4)	tsc_CCCH6 (6)	tsc_PCCH1 (1)
RLC mode	UM	AM	AM	AM	UM	TM
MAC priority	1	2	3	4	1	1
TrCH Type	DCH				FACH	PCH
TrCH identity	tsc_DL_DCH5 (10)				tsc_FACH2 (14)	tsc_PCH1 (13)
PhyCh Type	DPCH				Secondary CCPCH	
PhyCH identity	tsc_DL_DPCH1 (20)				tsc_S_CCPCH1 (5)	

8.3.3 Configuration of Cell_DCH_Speech

The configuration is based on 34.108, 6.10.2.4.1.4 and 6.10.2.4.1.5. The RB0/UM-CCCH is referred to 34.108, 6.10.2.4.3.2.1.2 and RB0/TM-CCCH is referred to 34.108, 6.10.2.4.4.1.1.1. The configuration is applied to those RRC and NAS signalling tests in the DCH state where a CS voice service, such as narrowband speech, emergency speech call or TS 61 for speech, is established.

Table 25: Uplink configuration of Cell_DCH_Speech

RB Identity	tsc_RB10 (10)	tsc_RB11 (11)	tsc_RB12 (12)	Tsc_RB1 (1)	tsc_RB2 (2)	tsc_RB3 (3)	tsc_RB4 (4)	tsc
LogCh Type	DTCH	DTCH	DTCH	DCCH	DCCH	DCCH	DCCH	CC
LogCh Identity	tsc_UL_DTCH1 (7)	tsc_UL_DTCH2 (8)	tsc_UL_DTCH3 (9)	tsc_UL_DCCH1 (1)	tsc_UL_DCCH2 (2)	tsc_UL_DCCH3 (3)	tsc_UL_DCCH4 (4)	tsc_C
RLC mode	TM	TM	TM	UM	AM	AM	AM	T
TrCH Type	DCH	DCH	DCH	DCH				R
TrCH identity	tsc_UL_DCH1 (1)	tsc_UL_DCH2 (2)	tsc_UL_DCH3 (3)	tsc_UL_DCH5 (5)				tsc_R (
PhyCh Type	DPDCH							PR
PhyCH identity	tsc_UL_DPCH1 (20)							tsc_P

Table 26: Downlink configuration of Cell_DCH_Speech

RB Identity	tsc_RB10 (10)	tsc_RB11 (11)	tsc_RB12 (12)	Tsc_RB1 (1)	tsc_RB2 (2)	tsc_RB3 (3)	tsc_RB4 (4)	tsc_RB0 (0)	tsc_RB H (7-
LogCh Type	DTCH	DTCH	DTCH	DCCH	DCCH	DCCH	DCCH	CCCH	PC
LogCh Identity	tsc_DL_DTCH1 (7)	tsc_DL_DTCH2 (8)	tsc_DL_DTCH3 (9)	tsc_DL_DCCH1 (1)	tsc_DL_DCCH2 (2)	tsc_DL_DCCH3 (3)	tsc_DL_DCCH4 (4)	tsc_CCCH6 (6)	tsc_PC (1
RLC mode	TM	TM	TM	UM	AM	AM	AM	UM	TM
MAC priority	1	1	1	1	2	3	4	1	1
TrCH Type	DCH	DCH	DCH	DCH				FACH	PC
TrCH identity	tsc_DL_DCH1 (6)	tsc_DL_DCH2 (7)	tsc_DL_DCH3 (8)	tsc_DL_DCH5 (10)				tsc_FACH 2 (14)	tsc_P (1
PhyCh Type	DPCH							Secondary CCP	
PhyCH identity	tsc_DL_DPCH1 (20)							tsc_S_CCPCH (5)	

8.3.4 Configuration of Cell_DCH_64kCSRAB_SRB

The configuration is based on 34.108, 6.10.2.4.1.13 for the conversational unknown quality class. The RB0/UM-CCCH is referred to 34.108, 6.10.2.4.3.2.1.2 and RB0/TM-CCCH is referred to 34.108, 6.10.2.4.4.1.1.1. The configuration is applied to those RRC and NAS signalling tests in the DCH state where one of the following CS transparent data services is established:

- Multimedia call 28.8 k bit/s, 3.1kHz Audio,
- Multimedia call 32 k bit/s, UDI,
- Multimedia call 33.6 k bit/s, 3.1kHz Audio,
- Multimedia call 56 k bit/s, RDI,
- Multimedia call 64 k bit/s, UDI,
- Asynchronous 3.1kHz Audio 28.8 k bit/s,
- Synchronous 3.1kHz Audio 28.8 k bit/s,
- Synchronous V.110 UDI up to 56 k bit/s,
- BTM RDI 56 k bit/s,

- BTM UDI 64 bit/s.

Table 27: Uplink configuration of Cell_DCH_64kCSRAB_SRB

RB Identity	tsc_RB10 (10)	tsc_RB1 (1)	tsc_RB2 (2)	tsc_RB3 (3)	tsc_RB4 (4)	tsc_RB0 (0)
LogCh Type	DTCH	DCCH	DCCH	DCCH	DCCH	CCCH
LogCh Identity	tsc_UL_DTCH1 (7)	tsc_UL_DCCH1 (1)	tsc_UL_DCCH2 (2)	tsc_UL_DCCH3 (3)	tsc_UL_DCCH4 (4)	tsc_CCCH5 (5)
RLC mode	TM	UM	AM	AM	AM	TM
TrCH Type	DCH	DCH				RACH
TrCH identity	tsc_UL_DCH1 (1)	tsc_UL_DCH5 (5)				tsc_RACH1 (15)
PhyCh Type	DPDCH					PRACH
PhyCH identity	tsc_UL_DPCH1 (20)					tsc_PRACH1 (8)

Table 28: Downlink configuration of Cell_DCH_64kCSRAB_SRB

RB Identity	tsc_RB10 (10)	tsc_RB1 (1)	tsc_RB2 (2)	tsc_RB3 (3)	tsc_RB4 (4)	tsc_RB0 (0)	tsc_RB_PCCH (7-2)
LogCh Type	DTCH	DCCH	DCCH	DCCH	DCCH	CCCH	PCCH
LogCh Identity	tsc_DL_DTCH1 (7)	tsc_DL_DCCH1 (1)	tsc_DL_DCCH2 (2)	tsc_DL_DCCH3 (3)	tsc_DL_DCCH4 (4)	tsc_CCCH6 (6)	tsc_PCCH1 (1)
RLC mode	TM	UM	AM	AM	AM	UM	TM
MAC priority	1	1	2	3	4	1	1
TrCH Type	DCH	DCH				FACH	PCH
TrCH identity	tsc_DL_DCH1 (6)	tsc_DL_DCH5 (10)				tsc_FACH2 (14)	tsc_PCH1 (13)
PhyCh Type	DPCH					Secondary CCPCH	
PhyCH identity	tsc_DL_DPCH1 (20)					tsc_S_CCPCH1 (5)	

8.3.5 Configuration of Cell_DCH_57_6kCSRAB_SRB

The configuration is based on 34.108, 6.10.2.4.1.17 for the streaming unknown quality class. The RB0/UM-CCCH is referred to 34.108, 6.10.2.4.3.2.1.2 and RB0/TM-CCCH is referred to 34.108, 6.10.2.4.4.1.1.1. The configuration is applied to those RRC and NAS signalling tests in the DCH state where one of the following CS non-transparent data services is established:

- Asynchronous 3.1kHz Audio up to 19.2 k bit/s,
- Asynchronous 3.1kHz Audio modem auto-bauding,
- Asynchronous V.110 UDI up to 38.4 k bit/s, except 28.8 k bit/s,
- Asynchronous V.120 up to 56 k bit/s,
- Asynchronous PIAFS up to 64 k bit/s,
- Asynchronous FTM up to 64 k bit/s,
- Synchronous 3.1kHz Audio up to 19.2 k bit/s,
- Synchronous V.110 UDI up to 56 k bit/s, except 28.8 k bit/s,

- Synchronous X.31 Flags Stuffing UDI up to 56 k bit/s,
- Synchronous V.120 up to 56 k bit/s,
- Synchronous BTM up to 64 k bit/s,
- TS61 FAX.

Table 29: Uplink configuration of Cell_DCH_57_6kCSRAB_SRB

RB Identity	tsc_RB10 (10)	tsc_RB1 (1)	tsc_RB2 (2)	tsc_RB3 (3)	tsc_RB4 (4)	tsc_RB0 (0)
LogCh Type	DTCH	DCCH	DCCH	DCCH	DCCH	CCCH
LogCh Identity	tsc_UL_DTCH1 (7)	tsc_UL_DCCH1 (1)	tsc_UL_DCCH2 (2)	tsc_UL_DCCH3 (3)	tsc_UL_DCCH4 (4)	tsc_CCCH5 (5)
RLC mode	TM	UM	AM	AM	AM	TM
TrCH Type	DCH	DCH				RACH
TrCH identity	tsc_UL_DCH1 (1)	tsc_UL_DCH5 (5)				tsc_RACH1 (15)
PhyCh Type	DPDCH					PRACH
PhyCH identity	tsc_UL_DPCH1 (20)					tsc_PRACH1 (8)

Table 30: Downlink configuration of Cell_DCH_57_6kCSRAB_SRB

RB Identity	tsc_RB10 (10)	tsc_RB1 (1)	tsc_RB2 (2)	tsc_RB3 (3)	tsc_RB4 (4)	tsc_RB0 (0)	tsc_RB_PCCH (7-2)
LogCh Type	DTCH	DCCH	DCCH	DCCH	DCCH	CCCH	PCCH
LogCh Identity	tsc_DL_DTCH1 (7)	tsc_DL_DCCH1 (1)	tsc_DL_DCCH2 (2)	tsc_DL_DCCH3 (3)	tsc_DL_DCCH4 (4)	tsc_CCCH6 (6)	tsc_PCCH1 (1)
RLC mode	TM	UM	AM	AM	AM	UM	TM
MAC priority	1	1	2	3	4	1	1
TrCH Type	DCH	DCH				FACH	PCH
TrCH identity	tsc_DL_DCH1 (6)	tsc_DL_DCH5 (10)				tsc_FACH2 (14)	tsc_PCH1 (13)
PhyCh Type	DPCH					Secondary CCPCH	
PhyCH identity	tsc_DL_DPCH1 (20)					tsc_S_CCPCH1 (5)	

8.3.6 Configuration of Cell_DCH_AM_UM_RAB_7Lis

The configuration is based on 34.123-1, table 7.2/1, 7.2/3A and 7.2/3B for the RLC AM and UM tests with 7 bit length indicators. The RB0/UM-CCCH is referred to 34.108, 6.10.2.4.3.2.1.2 and RB0/TM-CCCH is referred to 34.108, 6.10.2.4.4.1.1.1.

Table 31: Uplink configuration of Cell_DCH_AM_UM_7Lis

RB Identity	tsc_RB10 (10)	tsc_RB1 (1)	tsc_RB2 (2)	tsc_RB3 (3)	tsc_RB4 (4)	tsc_RB0 (0)
LogCh Type	DTCH	DCCH	DCCH	DCCH	DCCH	CCCH
LogCh Identity	tsc_UL_DTCH1 (7)	tsc_UL_DCCH1 (1)	tsc_UL_DCCH2 (2)	tsc_UL_DCCH3 (3)	tsc_UL_DCCH4 (4)	tsc_CCCH5 (5)
RLC mode	TM	UM	AM	AM	AM	TM
TrCH Type	DCH					RACH
TrCH identity	tsc_UL_DCH5 (5)					tsc_RACH1 (15)
PhyCh Type	DPDCH					PRACH
PhyCH identity	tsc_UL_DPCH1 (20)					tsc_PRACH1 (8)

Table 32: Downlink configuration of Cell_DCH_AM_UM_7Lis

RB Identity	tsc_RB10 (10)	tsc_RB1 (1)	tsc_RB2 (2)	tsc_RB3 (3)	tsc_RB4 (4)	tsc_RB0 (0)	tsc_RB_PCCH (7-2)
LogCh Type	DTCH	DCCH	DCCH	DCCH	DCCH	CCCH	PCCH
LogCh Identity	tsc_DL_DTCH1 (7)	tsc_DL_DCCH1 (1)	tsc_DL_DCCH2 (2)	tsc_DL_DCCH3 (3)	tsc_DL_DCCH4 (4)	tsc_CCCH6 (6)	tsc_PCCH1 (1)
RLC mode	TM	UM	AM	AM	AM	UM	TM
MAC priority	5	1	2	3	4	1	1
TrCH Type	DCH					FACH	PCH
TrCH identity	tsc_DL_DCH5 (10)					tsc_FACH2 (14)	tsc_PCH1 (13)
PhyCh Type	DPCH					Secondary CCPCH	
PhyCH identity	tsc_DL_DPCH1 (20)					tsc_S_CCPCH1 (5)	

8.3.7 Configuration of Cell_DCH_AMRAB_15Lis

The configuration is based on 34.123-1, table 7.2/4A and 7.2/4B for the RLC AM tests with 15 bit length indicators. The RB0/UM-CCCH is referred to 34.108, 6.10.2.4.3.2.1.2 and RB0/TM-CCCH is referred to 34.108, 6.10.2.4.4.1.1.1.

Table 33: Uplink configuration of Cell_DCH_AMRAB_15Lis

RB Identity	tsc_RB10 (10)	tsc_RB1 (1)	tsc_RB2 (2)	tsc_RB3 (3)	tsc_RB4 (4)	tsc_RB0 (0)
LogCh Type	DTCH	DCCH	DCCH	DCCH	DCCH	CCCH
LogCh Identity	tsc_UL_DTCH1 (7)	tsc_UL_DCCH1 (1)	tsc_UL_DCCH2 (2)	tsc_UL_DCCH3 (3)	tsc_UL_DCCH4 (4)	tsc_CCCH5 (5)
RLC mode	TM	UM	AM	AM	AM	TM
TrCH Type	DCH	DCH				RACH
TrCH identity	tsc_UL_DCH1 (1)	tsc_UL_DCH5 (5)				tsc_RACH1 (15)
PhyCh Type	DPDCH					PRACH
PhyCH identity	tsc_UL_DPCH1 (20)					tsc_PRACH1 (8)

Table 34: Downlink configuration of Cell_DCH_AMRAB_15Lis

RB Identity	tsc_RB10 (10)	tsc_RB1 (1)	tsc_RB2 (2)	tsc_RB3 (3)	tsc_RB4 (4)	tsc_RB0 (0)	tsc_RB_P (7-2)
LogCh Type	DTCH	DCCH	DCCH	DCCH	DCCH	CCCH	PCCH
LogCh Identity	tsc_DL_DTCH1 (7)	tsc_DL_DCCH1 (1)	tsc_DL_DCCH2 (2)	tsc_DL_DCCH3 (3)	tsc_DL_DCCH4 (4)	tsc_CCCH6 (6)	tsc_PCC (1)
RLC mode	TM	UM	AM	AM	AM	UM	TM
MAC priority	1	1	2	3	4	1	1
TrCH Type	DCH	DCH				FACH	PCH
TrCH identity	tsc_DL_DCH1 (6)	tsc_DL_DCH5 (10)				tsc_FACH2 (14)	tsc_PC (13)
PhyCh Type	DPCH					Secondary CCPCH	
PhyCH identity	tsc_DL_DPCH1 (20)					tsc_S_CCPCH1 (5)	

8.3.8 Configuration of Cell_DCH_UMRAB_15Lis

The configuration is based on 34.123-1, table 7.2/2A and 7.2/2B for the RLC UM tests with 15 bit length indicators. The RB0/UM-CCCH is referred to 34.108, 6.10.2.4.3.2.1.2 and RB0/TM-CCCH is referred to 34.108, 6.10.2.4.4.1.1.1.

Table 35: Uplink configuration of Cell_DCH_UMRAB_15Lis

RB Identity	tsc_RB10 (10)	tsc_RB1 (1)	tsc_RB2 (2)	tsc_RB3 (3)	tsc_RB4 (4)	tsc_RB0 (0)
LogCh Type	DTCH	DCCH	DCCH	DCCH	DCCH	CCCH
LogCh Identity	tsc_UL_DTCH 1 (7)	tsc_UL_DCCH1 (1)	tsc_UL_DCCH2 (2)	tsc_UL_DCCH3 (3)	tsc_UL_DCCH4 (4)	tsc_CCCH5 (5)
RLC mode	TM	UM	AM	AM	AM	TM
TrCH Type	DCH	DCH				RACH
TrCH identity	tsc_UL_DCH1 (1)	tsc_UL_DCH5 (5)				tsc_RACH1 (15)
PhyCh Type	DPDCH					PRACH
PhyCH identity	tsc_UL_DPCH1 (20)					tsc_PRACH 1 (8)

Table 36: Downlink configuration of Cell_DCH_UMRAB_15Lis

RB Identity	tsc_RB10 (10)	tsc_RB1 (1)	tsc_RB2 (2)	tsc_RB3 (3)	tsc_RB4 (4)	tsc_RB0 (0)	tsc_RB_PCC H (7-2)
LogCh Type	DTCH	DCCH	DCCH	DCCH	DCCH	CCCH	PCCH
LogCh Identity	tsc_DL_DTCH 1 (7)	tsc_DL_DCCH1 (1)	tsc_DL_DCCH2 (2)	tsc_DL_DCCH3 (3)	tsc_DL_DCCH4 (4)	tsc_CCCH 6 (6)	tsc_PCCH1 (1)
RLC mode	TM	UM	AM	AM	AM	UM	TM
MAC priority	1	1	2	3	4	1	1
TrCH Type	DCH	DCH				FACH	PCH
TrCH identity	tsc_DL_DCH1 (6)	tsc_DL_DCH5 (10)				tsc_FACH2 (14)	tsc_PCH1 (13)
PhyCh Type	DPCH					Secondary CCPCH	
PhyCH identity	tsc_DL_DPCH1 (20)					tsc_S_CCPCH1 (5)	

8.3.9 Configuration of Cell_DCH_AMRAB_7_15Lis

The configuration is based on 34.123-1, 7.2.3.2.4 for the RLC AM tests involving selection of 7 or 15 bit length indicators. The RB0/UM-CCCH is referred to 34.108, 6.10.2.4.3.2.1.2 and RB0/TM-CCCH is referred to 34.108, 6.10.2.4.4.1.1.1.

Table 37: Uplink configuration of Cell_DCH_AMRAB_7_15Lis

RB Identity	tsc_RB10 (10)	tsc_RB1 (1)	tsc_RB2 (2)	tsc_RB3 (3)	tsc_RB4 (4)	tsc_RB0 (0)
LogCh Type	DTCH	DCCH	DCCH	DCCH	DCCH	CCCH
LogCh Identity	tsc_UL_DTCH 1 (7)	tsc_UL_DCCH1 (1)	Tsc_UL_DCCH2 (2)	tsc_UL_DCCH3 (3)	tsc_UL_DCCH4 (4)	tsc_CCCH5 (5)
RLC mode	TM	UM	AM	AM	AM	TM
TrCH Type	DCH	DCH				RACH
TrCH identity	tsc_UL_DCH1 (1)	tsc_UL_DCH5 (5)				tsc_RACH1 (15)
PhyCh Type	DPDCH					PRACH
PhyCH identity	tsc_UL_DPCH1 (20)					tsc_PRACH 1 (8)

Table 38: Downlink configuration of Cell_DCH_AMRAB_7_15Lis

RB Identity	tsc_RB10 (10)	tsc_RB1 (1)	tsc_RB2 (2)	tsc_RB3 (3)	tsc_RB4 (4)	tsc_RB0 (0)	tsc_RB_PCC H (7-2)
LogCh Type	DTCH	DCCH	DCCH	DCCH	DCCH	CCCH	PCCH
LogCh Identity	tsc_DL_DTCH 1 (7)	tsc_DL_DCCH1 (1)	tsc_DL_DCCH2 (2)	tsc_DL_DCCH3 (3)	tsc_DL_DCCH4 (4)	tsc_CCCH 6 (6)	tsc_PCCH1 (1)
RLC mode	TM	UM	AM	AM	AM	UM	TM
MAC priority	1	1	2	3	4	1	1
TrCH Type	DCH	DCH				FACH	PCH
TrCH identity	tsc_DL_DCH1 (6)	tsc_DL_DCH5 (10)				tsc_FACH2 (14)	tsc_PCH1 (13)
PhyCh Type	DPCH					Secondary CCPCH	
PhyCH identity	tsc_DL_DPCH1 (20)					tsc_S_CCPCH1 (5)	

8.3.10 Configuration of Cell_DCH_UMRAB_7_15Lis

The configuration is based on 34.123-1, 7.2.2.2.4 for the RLC UM tests involving selection of 7 or 15 bit length indicators. The RB0/UM-CCCH is referred to 34.108, 6.10.2.4.3.2.1.2 and RB0/TM-CCCH is referred to 34.108, 6.10.2.4.4.1.1.1.

Table 39: Uplink configuration of Cell_DCH_UMRAB_7_15Lis

RB Identity	tsc_RB10 (10)	tsc_RB1 (1)	tsc_RB2 (2)	tsc_RB3 (3)	tsc_RB4 (4)	tsc_RB0 (0)
LogCh Type	DTCH	DCCH	DCCH	DCCH	DCCH	CCCH
LogCh Identity	tsc_UL_DTCH 1 (7)	tsc_UL_DCCH1 (1)	tsc_UL_DCCH2 (2)	tsc_UL_DCCH3 (3)	tsc_UL_DCCH4 (4)	tsc_CCCH5 (5)
RLC mode	TM	UM	AM	AM	AM	TM
TrCH Type	DCH	DCH				RACH
TrCH identity	tsc_UL_DCH1 (1)	tsc_UL_DCH5 (5)				tsc_RACH1 (15)
PhyCh Type	DPDCH					PRACH
PhyCH identity	tsc_UL_DPCH1 (20)					tsc_PRACH 1 (8)

Table 40: Downlink configuration of Cell_DCH_UMRAB_7_15Lis

RB Identity	tsc_RB10 (10)	tsc_RB1 (1)	tsc_RB2 (2)	tsc_RB3 (3)	tsc_RB4 (4)	tsc_RB0 (0)	tsc_RB_PCC H (7-2)
LogCh Type	DTCH	DCCH	DCCH	DCCH	DCCH	CCCH	PCCH
LogCh Identity	tsc_DL_DTCH 1 (7)	tsc_DL_DCCH1 (1)	tsc_DL_DCCH2 (2)	tsc_DL_DCCH3 (3)	tsc_DL_DCCH4 (4)	tsc_CCCH 6 (6)	tsc_PCCH1 (1)
RLC mode	TM	UM	AM	AM	AM	UM	TM
MAC priority	1	1	2	3	4	1	1
TrCH Type	DCH	DCH				FACH	PCH
TrCH identity	tsc_DL_DCH1 (6)	tsc_DL_DCH5 (10)				tsc_FACH2 (14)	tsc_PCH1 (13)
PhyCh Type	DPCH					Secondary CCPCH	
PhyCH identity	tsc_DL_DPCH1 (20)					tsc_S_CCPCH1 (5)	

8.3.11 Configuration of Cell_FACH_BMC

The configuration is based on 34.108, 6.10.2.4.3.2.1.2 for downlink and 34.108, 6.10.2.4.4.1.1.1 without RAB/DTCH for uplink. A RB30/CTCH is configured. The configuration is applied to the BMC and CBSMS tests.

Table 41: Uplink configuration of Cell_FACH_BMC

RB Identity	tsc_RB0 (0)	tsc_RB1 (1)	tsc_RB2 (2)	Tsc_RB3 (3)	tsc_RB4 (4)
LogCh Type	CCCH	DCCH	DCCH	DCCH	DCCH
LogCh Identity	tsc_CCCH 5 (5)	tsc_UL_DCCH1 (1)	tsc_UL_DCCH2 (2)	tsc_UL_DCCH3 (3)	tsc_UL_DCCH4 (4)
RLC mode	TM	UM	AM	AM	AM
TrCH Type	RACH				
TrCH identity	tsc_RACH1 (15)				
PhyCh Type	PRACH				
PhyCH identity	tsc_PRACH1 (8)				

Table 42: Downlink configuration of Cell_FACH_BMC

RB Identity	tsc_RB0 (0)	tsc_RB1 (1)	tsc_RB2 (2)	tsc_RB3 (3)	tsc_RB4 (4)	tsc_RB9 (9-3)	Tsc_RB30 (30)	tsc_RB (7)
LogCh Type	CCCH	DCCH	DCCH	DCCH	DCCH	BCCH	CTCH	PC
LogCh Identity	tsc_CCCH 6 (6)	tsc_DL_DCCH1 (1)	tsc_DL_DCCH2 (2)	tsc_DL_DCCH3 (3)	tsc_DL_DCCH4 (4)	tsc_BCCH 5 (5)	Tsc_CTC H (11)	tsc_P
RLC mode	UM	UM	AM	AM	AM	TM	UM	T
MAC priority	1	2	3	4	5	6	7	
TrCH Type	FACH							P
TrCH identity	tsc_FACH2 (14)							tsc_
PhyCh Type	Secondary CCPCH							
PhyCH identity	tsc_S_CCPCH1 (5)							

8.3.12 Configuration of PS_Cell_FACH

The configuration is based on 34.108, 6.10.2.4.3.2.1.2 for downlink and 34.108, 6.10.2.4.4.1.1.1 for uplink. The configuration is applied to the RRC tests requiring a PS RAB in the state CELL_FACH.

Table 43: Uplink configuration of PS_Cell_FACH

RB Identity	tsc_RB20 (20)	tsc_RB0 (0)	tsc_RB1 (1)	tsc_RB2 (2)	tsc_RB3 (3)	tsc_RB4 (4)
LogCh Type	DTCH	CCCH	DCCH	DCCH	DCCH	DCCH
LogCh Identity	Tsc_UL_DTCH 1 (7)	tsc_CCCH 5 (5)	tsc_UL_DCCH1 (1)	tsc_UL_DCCH2 (2)	tsc_UL_DCCH3 (3)	tsc_UL_DCCH4 (4)
RLC mode	AM	TM	UM	AM	AM	AM
TrCH Type	RACH					
TrCH identity	tsc_RACH1 (15)					
PhyCh Type	PRACH					
PhyCH identity	tsc_PRACH1 (8)					

Table 44: Downlink configuration of PS_Cell_FACH

RB Identity	tsc_RB20 (20)	tsc_RB0 (0)	tsc_RB1 (1)	tsc_RB2 (2)	tsc_RB3 (3)	tsc_RB4 (4)	tsc_RB9 (9-3)
LogCh Type	DTCH	CCCH	DCCH	DCCH	DCCH	DCCH	BCCH
LogCh Identity	tsc_DL_DTCH 1 (6)	tsc_CCCH 6 (6)	tsc_DL_DCCH1 (1)	tsc_DL_DCCH2 (2)	tsc_DL_DCCH3 (3)	tsc_DL_DCCH4 (4)	tsc_BCCH5 (5)
RLC mode	AM	UM	UM	AM	AM	AM	TM
MAC priority	1	1	2	3	4	5	6
TrCH Type	FACH	FACH					
TrCH identity	tsc_FACH1 (12)	tsc_FACH2 (14)					
PhyCh Type	Secondary CCPCH						
PhyCH identity	tsc_S_CCPCH1 (5)						

8.3.13 Configuration of PS Cell_DCH_64kPSRAB_SRB

The configuration is based on 34.108, 6.10.2.4.1.26. The RB0/UM-CCCH is referred to 34.108, 6.10.2.4.3.2.1.2 and RB0/TM-CCCH is referred to 34.108, 6.10.2.4.4.1.1.1. The configuration is applied to those RRC and NAS signalling tests in the DCH state where a PS RAB on DTCH is setup for the interactive or background service class.

Table 45: Uplink configuration of PS Cell_DCH_64kPSRAB_SRB

RB Identity	tsc_RB20 (20)	tsc_RB1 (1)	tsc_RB2 (2)	tsc_RB3 (3)	tsc_RB4 (4)	tsc_RB0 (0)
LogCh Type	DTCH	DCCH	DCCH	DCCH	DCCH	CCCH
LogCh Identity	tsc_UL_DTCH 1 (7)	tsc_UL_DCCH1 (1)	tsc_UL_DCCH2 (2)	tsc_UL_DCCH3 (3)	tsc_UL_DCCH4 (4)	tsc_CCCH5 (5)
RLC mode	AM	UM	AM	AM	AM	TM
TrCH Type	DCH	DCH				RACH
TrCH identity	tsc_UL_DCH1 (1)	tsc_UL_DCH5 (5)				tsc_RACH1 (15)
PhyCh Type	DPDCH					PRACH
PhyCH identity	tsc_UL_DPCH1 (20)					tsc_PRACH 1 (8)

Table 46: Downlink configuration of PS Cell_DCH_64kPSRAB_SRB

RB Identity	tsc_RB20 (20)	tsc_RB1 (1)	tsc_RB2 (2)	tsc_RB3 (3)	tsc_RB4 (4)	tsc_RB0 (0)	tsc_RB_PCC H (7-2)
LogCh Type	DTCH	DCCH	DCCH	DCCH	DCCH	CCCH	PCCH
LogCh Identity	tsc_DL_DTCH 1 (7)	tsc_DL_DCCH1 (1)	tsc_DL_DCCH2 (2)	tsc_DL_DCCH3 (3)	tsc_DL_DCCH4 (4)	tsc_CCCH 6 (6)	tsc_PCCH1 (1)
RLC mode	AM	UM	AM	AM	AM	UM	TM
MAC priority	1	1	2	3	4	1	1
TrCH Type	DCH	DCH				FACH	PCH
TrCH identity	tsc_DL_DCH1 (6)	tsc_DL_DCH5 (10)				tsc_FACH2 (14)	tsc_PCH1 (13)
PhyCh Type	DPCH					Secondary CCPCH	
PhyCH identity	tsc_DL_DPCH1 (20)					tsc_S_CCPCH1 (5)	

8.3.14 Configuration of Cell_DCH_Speech_4.75-7.95 kbps

The configuration is based on 34.108, 6.10.2.4.1.6 to 6.10.2.4.1.11. The RB0/UM-CCCH is referred to 34.108, 6.10.2.4.3.2.1.2 and RB0/TM-CCCH is referred to 34.108, 6.10.2.4.4.1.1.1. The configuration is applied to RB tests.

Table 47: Uplink configuration of Cell_DCH_Speech_4.75-7.95 kbps

RB Identity	tsc_RB10 (10)	tsc_RB11 (11)	Tsc_RB1 (1)	tsc_RB2 (2)	tsc_RB3 (3)	tsc_RB4 (4)	tsc_RB0 (0)
LogCh Type	DTCH	DTCH	DCCH	DCCH	DCCH	DCCH	CCCH
LogCh Identity	tsc_UL_DTCH1 (7)	tsc_UL_DTCH2 (8)	tsc_UL_DCCH1 (1)	tsc_UL_DCCH2 (2)	tsc_UL_DCCH3 (3)	tsc_UL_DC CH4 (4)	tsc_CCCH5 (5)
RLC mode	TM	TM	UM	AM	AM	AM	TM
TrCH Type	DCH	DCH	DCH				RACH
TrCH identity	tsc_UL_DCH1 (1)	tsc_UL_DCH2 (2)	tsc_UL_DCH5 (5)				tsc_RACH1 (15)
PhyCh Type	DPDCH						PRACH
PhyCH identity	tsc_UL_DPCH1 (20)						tsc_PRACH 1 (8)

Table 48: Downlink configuration of Cell_DCH_Speech_4.75-7.95 kbps

RB Identity	tsc_RB10 (10)	tsc_RB11 (11)	Tsc_RB1 (1)	tsc_RB2 (2)	tsc_RB3 (3)	tsc_RB4 (4)	tsc_RB0 (0)	tsc
LogCh Type	DTCH	DTCH	DCCH	DCCH	DCCH	DCCH	CCCH	
LogCh Identity	tsc_DL_DTCH1 (7)	tsc_DL_DTCH2 (8)	tsc_DL_DCCH1 (1)	tsc_DL_DCCH2 (2)	tsc_DL_DCCH3 (3)	tsc_DL_DCC H4 (4)	tsc_CCCH6 (6)	ts
RLC mode	TM	TM	UM	AM	AM	AM	UM	
MAC priority	1	1	1	2	3	4	1	
TrCH Type	DCH	DCH	DCH				FACH	
TrCH identity	tsc_DL_DCH1 (6)	tsc_DL_DCH2 (7)	tsc_DL_DCH5 (10)				tsc_FACH2 (14)	ts
PhyCh Type	DPCH						Secondary C	
PhyCH identity	tsc_DL_DPCH1 (20)						tsc_S_CCP (5)	

8.3.15 Configuration of Cell_single_DTCH (CS)

The configuration is based on 34.108, 6.10.2.4.1.12 to 6.10.2.4.1.22. The RB0/UM-CCCH is referred to 34.108, 6.10.2.4.3.2.1.2 and RB0/TM-CCCH is referred to 34.108, 6.10.2.4.4.1.1.1. The configuration is applied to RB tests.

Table 49: Uplink configuration of Cell_single_DTCH (CS)

RB Identity	tsc_RB10 (10)	Tsc_RB1 (1)	tsc_RB2 (2)	tsc_RB3 (3)	tsc_RB4 (4)	tsc_RB0 (0)
LogCh Type	DTCH	DCCH	DCCH	DCCH	DCCH	CCCH
LogCh Identity	tsc_UL_DTCH1 (7)	tsc_UL_DCC H1 (1)	tsc_UL_DCC H2 (2)	tsc_UL_DCC H3 (3)	tsc_UL_DCC H4 (4)	tsc_CCCH5 (5)
RLC mode	TM	UM	AM	AM	AM	TM
TrCH Type	DCH	DCH				RACH
TrCH identity	tsc_UL_DCH1 (1)	tsc_UL_DCH5 (5)				tsc_RACH1 (15)
PhyCh Type	DPDCH					PRACH
PhyCH identity	tsc_UL_DPCH1 (20)					tsc_PRACH1 (8)

Table 50: Downlink configuration of Cell_single_DTCH (CS)

RB Identity	tsc_RB10 (10)	Tsc_RB1 (1)	tsc_RB2 (2)	tsc_RB3 (3)	tsc_RB4 (4)	tsc_RB0 (0)	tsc_RB_PCC H (-2)
LogCh Type	DTCH	DCCH	DCCH	DCCH	DCCH	CCCH	PCCH
LogCh Identity	tsc_DL_DTCH1 (7)	tsc_DL_DCCH1 (1)	tsc_DL_DCCH2 (2)	tsc_DL_DCCH3 (3)	tsc_DL_DCCH4 (4)	tsc_CCCH6 (6)	tsc_PCCH1 (1)
RLC mode	TM	UM	AM	AM	AM	UM	TM
MAC priority	1	1	2	3	4	1	1
TrCH Type	DCH	DCH				FACH	PCH
TrCH identity	tsc_DL_DCH1 (6)	tsc_DL_DCH5 (10)				tsc_FACH2 (14)	tsc_PCH1 (13)
PhyCh Type	DPCH					Secondary CCPCH	
PhyCH identity	tsc_DL_DPCH1 (20)					tsc_S_CCPCH1 (5)	

8.4 System information blocks scheduling

All SIBs specified in 34.108 are broadcast for all test cases in 34.123-3. The repeat period of broadcasting of a complete SIB configuration is 128 frames (1.28 s) for Europe and 64 frames (0.64s) for Japan.

Except MIB and SB1, they have the highest scheduling rates, SIB 2, 3, 4 and 7 have a higher scheduling rate.

The configurations of SIBs are regionally dependent, for example: only FDD-related SIBs needed in Japan, SIB16 in Europe, SIB 13 series and SIB 15 series in the North America. The schedule and SIB configurations are therefore different for a same test case. A PIXIT question is included in the ATs to reflect the different regional requirements. Combination of one or several segments of variable length in the same SYSTEM INFORMATION message for testing is for further study.

According to the default SIB contents in 34.108, SB1, SIB1, SIB 11 and SIB12 have 2 segments. SIB 5 and SIB 6 have 3 segments. SIB 16 has 6 segments. MIB, SB1, SIB 2, SIB 3, SIB 4 and SIB 7 are not segmented, i.e. one segment for each.

Use CMAC_SYSINFO_CONFIG_REQ, CMAC_SYSINFO_CONFIG_CNF and RLC_TR_DATA_REQ as interface to SS for broadcasting.

Two TSOs are defined, one for PER encoding function, the other for segmentation function. The TSOs shall be implemented in the tester.

8.4.1 Grouping SIBs for testing

Mandatory in 34.108	Used in Idle Mode	MIB, SB1, (SB2), SIB1, SIB2, SIB3, SIB5, SIB7, SIB11
	Used in Connected Mode	SIB4, SIB6, SIB12
Mandatory for FDD CPCH		SIB8, SIB9
Mandatory for FDD DRAC		SIB10
Mandatory for TDD		SIB14, SIB17
Mandatory for LCS		SIB15, SIB15.1, SIB15.2, SIB15.3
Mandatory for ANSI-41 system		SIB13, SIB13.1, SIB13.2, SIB13.3, SIB13.4
Mandatory for InterSys HO		SIB16

8.4.2 SIB configurations

The ATs contains two SIB configurations, Configuration 1 for UTRAN/FDD SYSTEM and Configuration 2 for UTRAN/FDD and GERAN system. A PIXIT question related is raised for the selection of the SIB configuration for the test.

Configuration1)	MIB, SB1, SIB1, SIB2, SIB3, SIB4, SIB5, SIB6, SIB7, SIB11, SIB12
Configuration2	MIB, SB1, SIB1, SIB2, SIB3, SIB4, SIB5, SIB6, SIB7, SIB11, SIB12, SIB16

8.4.3 Test SIB schedule for UTRAN/FDD and GERAN system

Frame No.	0	2	4	6	8	10	12	14
REP-POS	0	1	2	3	4	5	6	7
Block Type	MIB	SB1	SB1	SIB3	MIB	SIB1	SIB1	SIB2

Frame No.	16	18	20	22	24	26	28	30
REP-POS	8	9	10	11	12	13	14	15
Block Type	MIB	SB1	SB1		MIB	SIB5	SIB5	SIB5

Frame No.	32	34	36	38	40	42	44	46
REP-POS	16	17	18	19	20	21	22	23
Block Type	MIB	SB1	SB1	SIB4	MIB	SIB6	SIB6	SIB6

Frame No.	48	50	52	54	56	58	60	62
REP-POS	24	25	26	27	28	29	30	31
Block Type	MIB	SB1	SB1	SIB7	MIB	SIB11	SIB11	

Frame No.	64	66	68	70	72	74	76	78
REP-POS	32	33	34	35	36	37	38	39
Block Type	MIB	SB1	SB1	SIB3	MIB	SIB16	SIB16	SIB16

Frame No.	80	82	84	86	88	90	92	94
REP-POS	40	41	42	43	44	45	46	47
Block Type	MIB	SB1	SB1	SIB16	MIB	SIB16	SIB16	

Frame No.	96	98	100	102	104	106	108	110
REP-POS	48	49	50	51	52	53	54	55
Block Type	MIB	SB1	SB1	SIB4	MIB	SIB12	SIB12	

Frame No.	112	114	116	118	120	122	124	126
REP-POS	56	57	58	59	60	61	62	63
Block Type	MIB	SB1	SB1	SIB7	MIB			

SIB-repeat period (in frame)

Block Type	MIB	SB1	SIB1	SIB2	SIB3	SIB4	SIB5	SIB6	SIB7	SIB11	SIB12	SIB16
SIB Rep	8	16	128	128	64	64	128	128	64	128	128	128
Max. No of seg.	1	2	2	1	1	1	3	3	1	2	2	6

8.4.4 Test SIB schedule for UTRAN FDD system

Frame No.	0	2	4	6	8	10	12	14
REP-POS	0	1	2	3	4	5	6	7
Block Type	MIB	SB1	SB1	SIB3	MIB	SIB1	SIB1	SIB2

Frame No.	16	18	20	22	24	26	28	30
REP-POS	8	9	10	11	12	13	14	15
Block Type	MIB	SB1	SB1	SIB7	MIB	SIB5	SIB5	SIB5

Frame No.	32	34	36	38	40	42	44	46
REP-POS	16	17	18	19	20	21	22	23
Block Type	MIB	SB1	SB1	SIB4	MIB	SIB6	SIB6	SIB6

Frame No.	48	50	52	54	56	58	60	62
REP-POS	24	25	26	27	28	29	30	31
Block Type	MIB	SB1	SB1	SIB11	MIB	SIB11	SIB12	SIB12

SIB-repeat period (in frame)

Block Type	MIB	SB1	SIB1	SIB2	SIB3	SIB4	SIB5	SIB6	SIB7	SIB11	SIB12
SIB Rep	8	16	64	64	64	64	64	64	64	64	64
Max. No of seg	1	2	2	1	1	1	3	3	1	2	2

8.4.5 Handling the transmission of SIB

According to the SIB repeat periods, SIBs need to be transmitted on a very regular basis during the operation of a test case. This transmission usually has no direct bearing on the operation of the test case, although the carried information ensures the correct configuration and operation of the UE during the test case.

To send this information repeatedly directly from each test case would make the test cases very complex to implement, difficult to understand and place real-time requirements upon them that are beyond the capabilities of most TTCN driven test engines.

Management of scheduling of System Information messages is performed by the system simulator. The SIB contents, usually determined in part by the individual tests, come from the TTCN test cases.

8.4.5.1 Delivery of System Information content

The content of the System Information messages is delivered as a fully encoded bit string to the TM-RLC SAP from the message content defined in the TTCN test case.

The IE 'SFNprime' in the SI messages is set to 0 by the TTCN, and the correct value of 'SFNprime' shall be inserted by the System Simulator prior to transmission of a SI message.

SI messages are ASN.1 packed encoded through a TTCN TSO and segmented another TTCN TSO into SIBs in the TTCN and sent only once to the TM-RLC SAP. Repetition of the SIB is the responsibility of the System Simulator lower layers.

SIBs are considered to be cached. That is, sending a SIB to the TM-RLC SAP will cause a previously sent copy of the SIB to be lost, and all future transmissions of the SIB will be the

most recently sent version. This allows for the updating of System Information during the operation of a test case.

8.4.5.2 Scheduling of System Information Blocks

The schedule for the transmission of SIBs is provided by the TTCN test case. It is sent using the CMAC_SYSINFO_CONFIG_REQ primitive sent to the CMAC SAP (CMAC_PCO).

Each CMAC_SYSINFO_CONFIG_REQ primitive carries scheduling information for the next SIB sent from the TTCN. Each primitive is followed by an associated SIB. Sending two CMAC_SYSINFO_CONFIG_REQ primitives in succession may cause an unspecified result.

8.4.5.3 Example of usage

The following sequence shows how some SIBs are sent to the System Simulator lower layers, together with scheduling information:

```
CMAC_PCO:      CMAC_SYSINFO_CONFIG_REQ (8, 0)
TM_PCO:        MIB
CMAC_PCO:      CMAC_SYSINFO_CONFIG_REQ (16, 1)
TM_PCO:        SB1 (segment 1 of 2)
CMAC_PCO:      CMAC_SYSINFO_CONFIG_REQ (16, 2)
TM_PCO:        SB1 (segment 2 of 2)
CMAC_PCO:      CMAC_SYSINFO_CONFIG_REQ (64, 3)
TM_PCO:        SIB3 (segment 1 of 1)
CMAC_PCO:      CMAC_SYSINFO_CONFIG_REQ (8, 4)
TM_PCO:        MIB
CMAC_PCO:      CMAC_SYSINFO_CONFIG_REQ (128, 5)
TM_PCO:        SIB1 (segment 1 of 2)
...

```

8.5 Security in testing

The security functions in the SS side are implemented in RLC and MAC layers. The NAS and RRC TTCN relevant test steps communicate with the L2 emulator through PIXIT, TSOs and ASPs.

8.5.1 Authentication

A GMM or MM authentication test step makes use of a number of TSOs to generate an authentication vector:

```
AV := {RAND, XRES, CK, IK, AUTN}
```

8.5.2 Ciphering

tbd

8.5.3 Integrity

tbd

8.5.4 Counter check

tbd

8.5.5 Test USIM

tbd

8.6 Downlink power control in SS

tbd

8.7 Test suite operation definitions

Table 47: TSO definitions

TSO Name	Description
o_AuthRspChk	<p>Type of the result: BOOLEAN</p> <p>Parameters: p_AuthRsp : AuthRsp p_AuthRspExt : AuthRspExt p_Ki : BITSTRING p_RAND : BITSTRING p_Ext : BOOLEAN</p> <p>Description Checks the input parameter p_AuthRsp and p_AuthRspExt, both received in an Authentication Response, according to the authentication algorithm defined in the following procedure. The extension, p_AuthRspExt, is optional. Its presence is indicated by p_Ext. Returns TRUE if the Authentication Response contained in parameters p_AuthRsp and eventually p_AuthRspExt is correct, FALSE otherwise. The value of tcv_Auth_n indicates whether the AuthRspExt has been provided by the UE or not (n=31, or 31 < n < 128). See 3GPP TS 34.108 cl. 8.1.2. If not the parameter p_AuthRspExt is not to be used.</p> <p>Algorithm (without the knowledge of tcv_Auth_n): =====</p> <pre> if NOT p_Ext EvaluateAuthRsp else EvaluateAuthRspAndAuthRspExt EvaluateAuthRsp: ===== resultbitstring = o_BitstringXOR(XRES, AuthRsp) if resultbitstring is all 0s then there is a match. EvaluateAuthRspAndAuthRspExt: ===== XREShigh = o_BitstringXtract(XRES, 32, 32, 0) /* XRES divides into 2 parts: the higher part of 32 bits related to AuthRsp and the lower part related to AuthRspExt */ /* SourceLength of 32 is only to ensure usage of the procedure */ resultbitstring = o_BitstringXOR(XREShigh, AuthRsp) if resultbitstring is all 0s then there is a match for the first 32 bits:EvaluateAuthRspExt else Authentication failed. EvaluateAuthRspExt: ===== /* As AuthRspExt may not be octet aligned the last octet indicated in AuthRspExt is not used for checking */ if (AuthRspExt.iel = 1) then Authentication passed /* there was only 1 possibly incomplete octet which is not used */ else { AuthRspExthigh = o_BitstringXtract(AuthRspExt.authRsp, ((AuthRspExt.iel -1)* 8), (AuthRspExt.iel -1)* 8, 0) /* extract (AuthRspExt.iel -1)* 8 bits starting from bit 0 */ XRESlow = o_BitstringXtract(XRES, ((AuthRspExt.iel -1)* 8 + 32), (AuthRspExt.iel -1)* 8, 32) /* extract (AuthRspExt.iel -1)* 8 bits starting from bit 32 */ resultbitstring = o_BitstringXOR(XRESlow, AuthRspExthigh, (AuthRspExt.iel -1)* 8) if resultbitstring is all 0s then there is a match for the bits following the first 32 bits else Authentication failed </pre>
o_AuthSQN_Upd	<p>Type of the result: BOOLEAN</p> <p>Increments BITSTRING tsv_SQN so that it becomes available for use by the next</p>

	<p>authentication. Returns TRUE if the procedure succeeds, FALSE otherwise. Note : the incrementation algorithm is to be specified. Not yet known. ???</p>
o_BitstringChange	<p>Type of the result: BITSTRING Parameters: P_Str: BITSTRING p_Len: INTEGER p_Offset: INTEGER</p> <p>Description Performs the manipulation of a bitstring by toggling the bit identified by p_Offset. The length of the string to be manipulated is specified in p_Len. This is only provided to help ensure that the p_Offset is less than p_Len. Returns a resulting bitstring of length p_Len. Examples: o_BitstringChange('010101'B, 6, 5) produces '010100'B. o_BitstringChange('010101'B, 6, 0) produces '110101'B.</p>
o_BitstringConcat	<p>Type of the result: BITSTRING Parameters: P_Str1: BITSTRING p_Str2: BITSTRING p_Len1: INTEGER p_Len2: INTEGER</p> <p>Description Performs the concatenation of 2 bitstrings of possibly different lengths. The bit significance is from left to right, ie the MSB is at the lefthand side. Returns a resulting bitstring p_Str1 p_Str2 of length p_Len1 + p_Len2. Example: o_BitstringConcat('010101'B,'11'B) produces '01010111'B of length 6 + 2 = 8.</p>
o_BitstringXOR	<p>Type of the result: BITSTRING Parameters: P_Str1: BITSTRING p_Str2: BITSTRING p_Len: INTEGER</p> <p>Description Performs an XOR operation using 2 bitstrings of the same length (p_Len). Returns a resulting Bitstring of length p_Len. Example: o_BitstringXOR('0011'B, '0101'B, 4) produces '0110'B</p>
o_BitstringXtract	<p>Type of the result: BITSTRING Parameters: P_Str: BITSTRING p_SrcLen: INTEGER p_TargetLen: INTEGER p_Offset: INTEGER</p> <p>Description Performs the wrap around extract of a bitstring. The length of the string from which extraction is to be made is specified in p_SrcLen. The length of the bitstring to be extracted is indicated as p_TargetLen, the offset in the original string is indicated in p_Offset. <u>The bit position 0 is at the left, the MSB is at the righthand side.</u> <u>Returns a resulting bitstring of length p_TargetLen. The bit significance is from left to right, ie the MSB is at the lefthand side.</u> <u>Returns a resulting bitstring of length p_TargetLen.</u> Examples: <u>o_BitstringXtract('101010'B, 6, 2, 1) produces '01'B.</u> <u>o_BitstringXtract('101010'B, 6, 4, 3) produces '0101'B, wrapping around.</u> <u>o_BitstringXtract('111000'B, 6, 4, 3) produces '0111'B, wrapping around.</u> <u>o_BitstringXtract('010101'B, 6, 2, 1) produces '10'B.</u> <u>o_BitstringXtract('010101'B, 6, 4, 3) produces '1010'B, wrapping around.</u></p>

	o_BitstringXtract('000111'B, 6, 4, 3) produces '1110'B, wrapping around.
o_CheckStringStartWith	<p>Type of the result:BOOLEAN</p> <p>Parameters: p_SourceString: IA5String p_StartString : IA5String</p> <p>Description o_CheckStringStartWith returns TRUE if the p_sourceString start with the p_StartString. Otherwise it returns FALSE. For example: o_CheckStringStartWith ("+CLCC:1,0,0,2,0;", "+CLCC:1,0,0")=TRUE */</p>
o_ConcatStrg	<p>Type of the result: IA5String</p> <p>Parameters: P_String1: IA5String p_String2: IA5String</p> <p>Description o_ConcatString concatenates 'p_String1' and 'p_String2' and returns the resulting string. For example: o_ConcatString ("AT+CBST=0" , ",0") = "AT+CBST=0,0"</p>
o_ConvertIMSI	<p>Type of the result: IMSI_GSM_MAP</p> <p>Parameters: P_Imsi : HEXSTRING The input parameter `p_Imsi` is a BCD string (subset of HEXSTRING), the result is of type IMSI_GSM_MAP.</p>
o_ConvertTMSI	<p>Type of the result:TMSI_GSM_MAP</p> <p>Parameters: p_Tmsi : OCTETSTRING</p> <p>Description The input parameter `p_Tmsi` is an OCTETSTRING; the result is of type TMSI_GSM_MAP.</p>
o_ConvtAndConcatStr	<p>Type of the result:OCTETSTRING</p> <p>Parameters: p_MCC, p_MNC : HEXSTRING; p_LAC : OCTETSTRING</p> <p>Description functions of o_ConvtAndConcatStr are as following: 1. The least significant HEX of p_MNC is removed from p_MNC and inserted into p_MCC in the position left to the third HEX to form a new p_MCC of 4 HEXs, then swap the first HEX (left most, most significant Hex) with the second HEX of the new p_MCC. 2. Swap the first Hex with the second HEX of the remaining part of p_MNC and append it to the new p_MCC formed in step1 above. 3. Append p_LAC to the result of step 2, this is the final result.</p>
o_FirstDigit	<p>Type of the result: B4</p> <p>Parameters: p_BCDdigits : HEXSTRING</p> <p>Description The input parameter p_BCDdigits shall be a BCD string (subset of HEXSTRING), the result is a BITSTRING[4] of a binary representation of one BCD digit. The function of the o_FirstDigit is to return the first (most significant) digit of the input parameter `p_BCDdigits`. for example: o_FirstDigit('12345') = '0001'B, o_FirstDigit('012345678') = '0000'B.</p>
o_GetBit	<p>Type of the result: BITSTRING</p> <p>Parameters: p_Source: BITSTRING p_DataLength:INTEGER</p> <p>Description</p>

<p>o_GetN_OctetsFromPRBS</p>	<p>o_GetBit returns the BITSTRING of length p_DataLength extracted from p_Source.</p> <p>Type of the result:OCTETSTRING</p> <p>Parameters: p_Start, p_N: INTEGER</p> <p>Description This operation returns N octets from a repeated pseudo random bit sequence, starting with octet position p_Start. The PRBS is the 2047 bit pseudo random test pattern defined in ITU-T Recommendation O.153 for measurements at 64 kbit/s and N x 64 kbit/s o_GetN_OctetsFromPRBS(p_Start, p_N) generates an OCTETSTRING containing p_N octets starting from octet number p_Start in the PRBS.</p> <p>Requirements p_Start >= 0 p_N >= 1</p> <p>Definition Define the 2047 bit PRBS sequence b(i) as an m-sequence produced by using the following primitive (over GF(2)) generator polynomial of degree 11: $X^{11} + X^9 + 1$ This sequence is defined recursively as: $b(i) = 1$, i = 0,1,...,10 $b(i) = b(i - 2) + b(i - 11)$ modulo 2 , i = 11,16,...,2046</p> <p>The OCTETSTRING, o(j) generated by the present TSO is produced by extracting p_N octets from the repeated sequence b(i) as follows: $o(j,k) = b((n_Start + j) * 8 + k)$ modulo 2047)</p> <p>where: j = 0,1,...,p_N - 1 k = 0,1,..7 o(j,k) is the kth bit of the jth octet in o(j), o(j,0) is the MSB of the jth octet in o(j), o(j,7) is the LSB of the jth octet in o(j),</p> <p>Example results: o_GetN_OctetsFromPRBS(0, 25) and o_GetN_OctetsFromPRBS(2047, 25) both return: 'FFE665A5C5CA3452085408ABEECE4B0B813FD337873F2CD1E2'O o_GetN_OctetsFromPRBS(255, 25) and o_GetN_OctetsFromPRBS(255 + 2047, 25) both return '01FFCCCB4B8B9468A410A81157DD9C9617027FA66F0E7E59A3'O</p>
<p>o_GetPI</p>	<p>Type of the result: B18</p> <p>Parameters: p_lmsi : HEXSTRING p_DrxCycle: INTEGER p_Pbp: INTEGER p_Np: INTEGER</p> <p>Description The operation is used to calculate the PI (Page Indicator) from the given input parameters. The PI is calculated as following: $PI = drx_index \text{ mod } np$ The drx_index is calculated as described hereafter: $drx_index = (p_lmsi / (p_DrxCycle / p_Pbp))$</p>
<p>o_HexToDigitsMCC</p>	<p>Type of the result:MCC</p> <p>Parameters: p_BCDdigits : HEXSTRING</p> <p>Description The input parameter p_BCDdigits shall be a BCD string (subset of HEXSTRING), the result is a SEQUENCE (SIZE(3)) OF digit (MCC). NOTE: The length of p_BCDdigits shall be 3. User shall take the responsibility of fulfilling this requirement. for example: o_HexToDigitsMCC('111'H) = {1, 1, 1} o_HexToDigitsMCC('123'H) = {1, 2, 3}.</p>

o_HexToDigitsMNC	<p>Type of the result:MNC Parameters: p_BCDdigits : HEXSTRING</p> <p>Description The function of this operation is: 1. the least significant HEX is removed if it is 'F' and the operation returns SEQUENCE (SIZE(2)) OF Digit. 2. the operation returns SEQUENCE (SIZE(3)) OF Digit if all 3 HEX digits in p_BCDdigits are BCD Digit. for example: o_HexToDigitsMNC('123'H) = {1, 2, 3} o_HexToDigitsMNC('13F'H) = {1, 3}.</p>
o_HexToIA5	<p>Type of the result: IA5String Parameters: p_String: HEXSTRING</p> <p>Description o_HEX_TO_IA5 converts hexadecimal string 'p_String' to an IA5 String For example: o_HEX_TO_IA5 ('15A'H) = "15A"</p>
o_IA5ToOct	<p>Type of the result:OCTETSTRING Parameters: p_String : IA5String</p> <p>Description o_IA5_TO_OCT convert the string 'p_String' from IA5String type to OCTETSTRING. o_IA5_TO_OCT shall use '1111'B as an end mark, in the case of an odd number of number digits. For example: o_IA5_TO_OCT ("15A") = '15AF'O</p>
o_IntToOct	<p>Type of the result:OCTETSTRING Parameters: p_N : INTEGER p_L: INTEGER</p> <p>Description o_IntToOct converts the INTEGER `p_N` into OCTETSTRING with length = `p_L`. for example: o_IntToOct(14,1) = '0E'O; o_IntToOct(18,1) = '12'O; o_IntToOct(18,2) = '0012'O.</p>
o_OctetstringConcat	<p>Type of the result:OCTETSTRING Parameters: p_Str1, p_Str2: OCTETSTRING</p> <p>Description o_OctetstringConcat Performs the concatenation of 2 octetstrings of possibly different lengths. The octet significance is from left to right, i.e. the MSB is at the lefthand side. Returns a resulting octetstring p_Str1 p_Str2. Example: o_OctetstringConcat('135'O, '9A38'O) = '1359A38'O.</p>
o_OctToBit	<p>Type of the result: BITSTRING Parameters: p_octetStr: OCTETSTRING</p> <p>Description Converts an OCTETSTRING into a BITSTRING. The size of the resulting BITSTRING is 8 times the size of the input OCTETSTRING.</p>
o_OctToInt	<p>Type of the result: INTEGER Parameters:</p>

	<p><u>p_oct : OCTETSTRING</u></p> <p>Description <u>Transform an OCTETSTRING of length 1 to 4 into an unsigned 32 bits IINTEGER value. If the input octet string is larger than 4, then only the first 4 octets shall be considered.</u></p>
o_OeBit	<p>Type of the result:BITSTRING</p> <p>Parameters: p_BCDdigits: HEXSTRING</p> <p>Description The input parameter `p_BCDdigits` is a BCD string (subset of HEXSTRING), the result is BITSTRING[1]. The function of the o_OeBit is as the follows: 1. it returns '1'B, if the length of the `p_BCDdigits` is odd, 2. it returns '0'B, if the length of the `p_BCDdigits` is even. for example: o_OeBit('12583') = '1'B, o_OeBit('87259957') = '0'B.</p>
o_OtherDigits	<p>Type of the result:OCTETSTRING</p> <p>Parameters: p_BCDdigits : HEXSTRING</p> <p>The input parameter `p_BCDdigits` is a BCD string (subset of HEXSTRING), the result is an even string of BCD digits, with eventually a filler 'F'H used. */</p> <p>The function of the o_OtherDigits is as the follows: 1. If the number of the `p_BCDdigits` is odd, the operation removes the most significant digit, and then reverses the order of each pair of digits; 2. If the number of the `p_BCDdigits` is even, first the operation suffixes the `bcdigits` with 'F'H, then removes the most significant digit, and then reverses the order of each pair of digits. for example: o_OtherDigi('12345') = '3254', o_OtherDigi('12345678') = '325476F8'. See o_FirstDigit for the handling of the first digit.</p>
o_SendInSameFrame	<p>Type of the result: BOOLEAN</p> <p>Parameters: p_NumberMsg : INTEGER</p> <p>Description o_SendInSameFrame is called to request SS to send the p_NumberMsg messages in the same frame. Then it returns TRUE.</p>
o_SIB_PER_Encoding	<p>Type of the result:BITSTRING</p> <p>Parameters: p_SIB : SIB</p> <p>Description It returns the unaligned PER encoding (BIT STRING) of the input system information block p_SIB. Example: for the following SIBType1 value: SysInfoType1 ::= { cn-CommonGSM-MAP-NAS-SysInfo '32F4100001'H, cn-DomainSysInfoList { { cn-DomainIdentity ps-domain, cn-Type gsm-MAP : '0000'H, cn-DRX-CycleLengthCoeff 7}, {cn-DomainIdentity cs-domain, cn-Type gsm-MAP : '0001'H, cn-DRX-CycleLengthCoeff 7}}, ue-ConnTimersAndConstants { t-304 ms100, n-304 7,</p>

	<pre> t-308 ms40, t-309 8, t-313 15, n-313 s200, t-314 s20, t-315 s1800, n-315 s1000}, ue-IdleTimersAndConstants { t-300 ms400, n-300 7, t-312 10, n-312 s200}, nonCriticalExtensions { } } </pre> <p>The operation returns BITSTRING: "1000011001011110100000100000000000000000000101100010000000000000000100 0010000000000000001010000110011000001111100000111001111111111111111111 00101111010011"</p>
o_SIB_Segmentation	<p>Type of the result: SegmentsOfSysInfoBlock</p> <p>Parameters: p_SIBBitString : BITSTRING</p> <p>Description Function of o_SIBSegmentation is as following:</p> <ol style="list-style-type: none"> 1. The input operand p_SIBBitString is segmented from left to right into segments, each segment except the last one is 222 bits . The last segment may be 222 bits or shorter. If the length of last segment is great than 214 bits pad it to 222 bits with padding bits set to '0'. 2. The number of segments is assigned to segCount field of the result. 3. The first segment is assigned to seg1 field of the result, the second segment is assigned to the seg2 field of the result, the third segment is assigned to the seg3 field of the result, and so on till the last segment.

8.8 AT commands

The table below shows a list of AT commands. By using these commands the ATs communicate with the SS for an automatic execution. The column 'ATS' indicates in which ATS the command is used.

Table 48: AT commands used in 3GPP ATs

Command	Reference	ATS
A	TS 27.007 [23]	RRC, NAS, SMS
+CMOD	TS 27.007 [23]	RRC, NAS, SMS
+CBST	TS 27.007 [23]	RRC, NAS, SMS
D	TS 27.007 [23]	RRC, NAS, SMS
H	TS 27.007 [23]	NAS
+CLCC	TS 27.007 [23]	NAS
+VTS	TS 27.007 [23]	NAS
+CGMF	TS 27.005 [22]	SMS
+CGMD	TS 27.005 [22]	SMS
+CGMR	TS 27.005 [22]	SMS
+CMGW	TS 27.005 [22]	SMS
+CMSS	TS 27.005 [22]	SMS
+CNMI	TS 27.005 [22]	SMS
+CPMS	TS 27.005 [22]	SMS
+CSMS	TS 27.005 [22]	SMS
+CSMP	TS 27.005 [22]	SMS
+CSCS	TS 27.005 [22]	SMS
+CSCA	TS 27.005 [22]	SMS
+CGDCONT	TS 27.007 [23]	NAS
+CGEQREQ	TS 27.007 [23]	NAS
+CGEREQMIN	TS 27.007 [23]	NAS
+CGDSCONT	TS 27.007 [23]	NAS
+CGACT	TS 27.007 [23]	NAS
+CSGMOD	TS 27.007 [23]	NAS
+CGATT	TS 27.007 [23]	NAS

Annex A (normative): Abstract Test Suites (ATS)

This annex contains the approved ATSs.

The ATSs have been produced using the Tree and Tabular Combined Notation (TTCN) according to TR 101 666 [27].

The ATSs were developed on a separate TTCN software tool and therefore the TTCN tables are not completely referenced in the table of contents. Each ATS contains a test suite overview part which provides additional information and references.

A.1 Version of specifications

The table below shows the version of the test specifications which the delivered ATSs are referred to.

Table 1: Versions of the test and Core specifications

Test specifications	TS 34.123-1 v330
	TS 34.123-2 v330
	TS 34.108 v330
	TS 34.109 v320

A.2 NAS ATS

The approved NAS test cases are listed.

Table A 1: NAS TTCN test cases

Test case	Description
	MM
tc_9_1	TMSI reallocation
tc_9_2_1	Authentication accepted
tc_9_2_2	Authentication rejected by the network
tc_9_2_3	Authentication rejected by the UE (MAC code failure)
tc_9_2_4	Authentication rejected by the UE (SQN failure)
tc_9_3_1	General Identification
tc_9_3_2	Handling of IMSI shorter than the maximum length.
tc_9_4_1	Location updating / accepted
tc_9_4_2_1	Location updating / rejected / IMSI invalid
tc_9_4_2_2_1	Location updating / rejected / PLMN not allowed – test 1
tc_9_4_2_2_2	Location updating / rejected / PLMN not allowed – test 2
tc_9_4_2_3	Location updating / rejected / location area not allowed
tc_9_4_2_4_1	Location updating rejected / roaming not allowed in this location area – procedure 1
tc_9_4_2_4_2	Location updating rejected / roaming not allowed in this location area – procedure 2
tc_9_4_2_4_3	Location updating rejected / roaming not allowed in this location area – procedure 3
tc_9_4_2_4_4	Location updating rejected / roaming not allowed in this location area – procedure 4
tc_9_4_2_4_5	Location updating rejected / roaming not allowed in this location area – procedure 5
tc_9_4_3_1	Location updating / abnormal cases / random access fails
tc_9_4_3_2	Location Updating / Abnormal cases / Attempt counter less or equal to 4, LAI different
tc_9_4_3_3	Location Updating / Abnormal cases/ Attempt Counter Equal to 4
tc_9_4_3_4	Location Updating / Abnormal cases / Attempt Counter less or equal to 4, stored LAI equal to broadcast
tc_9_4_4	Location updating / release / expiry of T3240
tc_9_4_5_1	Location updating / periodic spread
tc_9_4_5_2	Location updating / periodic normal / test 1
tc_9_4_5_3	Location updating / periodic normal / test 2
tc_9_4_5_4_1	Location Updating / Periodic HPLMN search / UE waits time T.
tc_9_4_5_4_2	Location Updating / Periodic HPLMN search / UE in manual mode
tc_9_4_5_4_3	Location Updating / Periodic HPLMN search / UE waits at least two minutes and at most T minutes
tc_9_4_6	Location updating / interworking of attach and periodic
tc_9_5_2	MM connection / establishment with cipher
tc_9_5_3	MM connection / establishment without cipher
tc_9_5_4	MM connection / establishment rejected
tc_9_5_5	MM connection / establishment rejected cause 4
tc_9_5_6	MM connection / expiry T3230
tc_9_5_7_1	MM connection / abortion by the network / cause #6
tc_9_5_7_2	MM connection / abortion by the network / cause not equal to #6
tc_9_5_8_1	MM connection / follow-on request pending / test 1
tc_9_5_8_2	MM connection / follow-on request pending / test 2
tc_9_5_8_3	MM connection / follow-on request pending / test 3
	CC
tc_10_1_2_1_1	Outgoing call / U0 null state / MM connection requested
tc_10_1_2_2_1	Outgoing call / U0.1 MM connection pending / CM service rejected
tc_10_1_2_2_2	Outgoing call / U0.1 MM connection pending / CM service accepted
tc_10_1_2_2_3	Outgoing call / U0.1 MM connection pending / lower layer failure
tc_10_1_2_3_1	Outgoing call / U1 call initiated / receiving CALL PROCEEDING
tc_10_1_2_3_2	Outgoing call / U1 call initiated / rejecting with RELEASE COMPLETE

tc_10_1_2_3_3	Outgoing call / U1 call initiated / T303 expiry
tc_10_1_2_3_4	Outgoing call / U1 call initiated / lower layer failure
tc_10_1_2_3_5	Outgoing call / U1 call initiated / receiving ALERTING
tc_10_1_2_3_6	Outgoing call / U1 call initiated / entering state U10
tc_10_1_2_3_7	Outgoing call / U1 call initiated / unknown message received
tc_10_1_2_4_1	Outgoing call / U3 UE originating call proceeding / ALERTING received
tc_10_1_2_4_2	Outgoing call / U3 UE originating call proceeding / CONNECT received
tc_10_1_2_4_3	Outgoing call / U3 UE originating call proceeding / PROGRESS received without in band information
tc_10_1_2_4_4	Outgoing call / U3 UE originating call proceeding // PROGRESS with in band information
tc_10_1_2_4_5	Outgoing call / U3 UE originating call proceeding / DISCONNECT with in band tones
tc_10_1_2_4_6	Outgoing call / U3 UE originating call proceeding / DISCONNECT without in band tones
tc_10_1_2_4_7	Outgoing call / U3 UE originating call proceeding / RELEASE received
tc_10_1_2_4_8	Outgoing call / U3 UE originating call proceeding / termination requested by the user
tc_10_1_2_4_9	Outgoing call / U3 UE originating call proceeding / traffic channel allocation
tc_10_1_2_4_10	Outgoing call / U3 UE originating call proceeding / timer T310 time-out
tc_10_1_2_4_11	Outgoing call / U3 UE originating call proceeding / lower layer failure
tc_10_1_2_4_12	Outgoing call / U3 UE originating call proceeding / unknown message received
tc_10_1_2_4_13	Outgoing call / U3 UE originating call proceeding / CONNECT received
tc_10_1_2_5_1	Outgoing call / U4 call delivered / CONNECT received
tc_10_1_2_5_2	Outgoing call / U4 call delivered / termination requested by the user
tc_10_1_2_5_3	Outgoing call / U4 call delivered / DISCONNECT with in band tones
tc_10_1_2_5_4	Outgoing call / U4 call delivered / DISCONNECT without in band tones
tc_10_1_2_5_5	Outgoing call / U4 call delivered / RELEASE received
tc_10_1_2_5_6	Outgoing call / U4 call delivered / lower layer failure
tc_10_1_2_5_7	Outgoing call / U4 call delivered / traffic channel allocation
tc_10_1_2_5_8	Outgoing call / U4 call delivered / unknown message received
tc_10_1_2_6_1	U10 call active / termination requested by the user
tc_10_1_2_6_2	U10 call active / RELEASE received
tc_10_1_2_6_3	U10 call active / DISCONNECT with in band tones
tc_10_1_2_6_4	U10 call active / DISCONNECT without in band tones
tc_10_1_2_6_5	U10 call active / RELEASE COMPLETE received
tc_10_1_2_6_6	U10 call active / SETUP received
tc_10_1_2_7_1	U11 disconnect request / clear collision
tc_10_1_2_7_2	U11 disconnect request / RELEASE received
tc_10_1_2_7_3	U11 disconnect request / timer T305 time-out
tc_10_1_2_7_4	U11 disconnect request / lower layer failure
tc_10_1_2_7_5	U11 disconnect request / unknown message received
tc_10_1_2_8_1	U12 disconnect indication / call releasing requested by the user
tc_10_1_2_8_2	U12 disconnect indication / RELEASE received
tc_10_1_2_8_3	U12 disconnect indication / lower layer failure
tc_10_1_2_8_4	U12 disconnect indication / unknown message received
tc_10_1_2_9_1	Outgoing call / U19 release request / timer T308 time-out
tc_10_1_2_9_2	Outgoing call / U19 release request / 2 nd timer T308 time-out
tc_10_1_2_9_3	Outgoing call / U19 release request / RELEASE received
tc_10_1_2_9_4	Outgoing call / U19 release request / RELEASE COMPLETE received
tc_10_1_2_9_5	Outgoing call / U19 release request / lower layer failure
tc_10_1_3_1_1	Incoming call / U0 null state / SETUP received with a non supported bearer capability
tc_10_1_3_2_1	Incoming call / U6 call present / automatic call rejection
tc_10_1_3_3_1	Incoming call / U9 mobile terminating call confirmed / alerting or immediate connecting
tc_10_1_3_3_2	Incoming call / U9 mobile terminating call confirmed / DTCH assignment

tc_10_1_3_3_3	Incoming call / U9 mobile terminating call confirmed / termination requested by the user
tc_10_1_3_3_4	Incoming call / U9 mobile terminating call confirmed / DISCONNECT received
tc_10_1_3_3_5	Incoming call / U9 mobile terminating call confirmed / RELEASE received
tc_10_1_3_3_6	Incoming call / U9 mobile terminating call confirmed / lower layer failure
tc_10_1_3_3_7	Incoming call / U9 mobile terminating call confirmed / unknown message received
tc_10_1_3_4_1	Incoming call / U7 call received / call accepted
tc_10_1_3_4_2	Incoming call / U7 call received / termination requested by the user
tc_10_1_3_4_3	Incoming call / U7 call received / DISCONNECT received
tc_10_1_3_4_4	Incoming call / U7 call received / RELEASE received
tc_10_1_3_4_5	Incoming call / U7 call received / lower layer failure
tc_10_1_3_4_6	Incoming call / U7 call received / DTCH assignment
tc_10_1_3_4_7	Incoming call / U7 call received / unknown message received
tc_10_1_3_4_8	Incoming call / U7 call received / RELEASE COMPLETE received
tc_10_1_3_5_1	Incoming call / U8 connect request / CONNECT acknowledged
tc_10_1_3_5_2	Incoming call / U8 connect request / timer T313 time-out
tc_10_1_3_5_3	Incoming call / U8 connect request / termination requested by the user
tc_10_1_3_5_4	Incoming call / U8 connect request / DISCONNECT received with in-band information
tc_10_1_3_5_5	Incoming call / U8 connect request / DISCONNECT received without in-band information
tc_10_1_3_5_6	Incoming call / U8 connect request / RELEASE received
tc_10_1_3_5_7	Incoming call / U8 connect request / lower layer failure
tc_10_1_3_5_8	Incoming call / U8 connect request / DTCH assignment
tc_10_1_3_5_9	Incoming call / U8 connect request / unknown message received
tc_10_1_4_1_1	In-call functions / DTMF information transfer / basic procedures
tc_10_1_4_2_1	In-call functions / User notification / UE terminated
tc_10_1_4_3_1	In-call functions / channel changes / a successful channel change in active state / Hard handover
tc_10_1_4_3_2	In-call function / channel changes / an unsuccessful channel change in active mode / Hard Handover
tc_10_3	User to user signalling
	Session Management
tc_11_1_1_1	Attach initiated by context activation/QoS Offered by Network is the QoS Requested
tc_11_1_1_2_1	QoS accepted by UE
tc_11_1_1_2_2	QoS rejected by UE
tc_11_1_2	PDP context activation requested by the network, successful and unsuccessful
tc_11_1_3_1	T3380 Expiry
tc_11_1_3_2	Collision of UE initiated and network requested PDP context activation
tc_11_1_3_3	Network initiated PDP context activation request for an already activated PDP context (on the UE side)
tc_11_1_4_1_1	QoS Offered by Network is the QoS Requested
tc_11_1_4_1_2_1	QoS accepted by UE
tc_11_1_4_1_2_2	QoS rejected by UE
tc_11_1_4_2	Unsuccessful Secondary PDP Context Activation Procedure Initiated by the UE
tc_11_1_4_3_1	T3380 Expiry
tc_11_3_1	Network initiated PDP context modification
tc_11_3_2	UE initiated PDP Context Modification accepted by network
tc_11_3_3_1	UE initiated PDP Context Modification not accepted by the network
tc_11_3_3_2	T3381 Expiry
tc_11_2_1	Collision of UE and network initiated PDP context modification procedures
tc_11_2_2_1	PDP context deactivation initiated by the UE
tc_11_2_3_1	PDP context deactivation initiated by the network
tc_11_2_2_2	T3390 Expiry
tc_11_2_3_2	Collision of UE and network initiated PDP context deactivation requests
tc_11_4_1	Error cases

	GPRS Mobility Management
tc 12 2 1 1	PS attach / accepted
tc 12 2 1 2	PS attach / rejected / IMSI invalid / illegal UE
tc 12 2 1 3	PS attach / rejected / IMSI invalid / PS services not allowed
tc 12 2 1 4	PS attach / rejected / IMSI invalid / PLMN not allowed
tc 12 2 1 5 1	PS attach / rejected / roaming not allowed in this location area / test procedure 1
tc 12 2 1 5 2	PS attach / rejected / roaming not allowed in this location area / test procedure 2
tc 12 2 1 5 3	PS attach / rejected / roaming not allowed in this location area / test procedure 3
tc 12 2 1 5 4	PS attach / rejected / roaming not allowed in this location area / test procedure 4
tc 12 2 1 6 1	PS attach / abnormal cases / access barred due to access class control / procedure 1
tc 12 2 1 6 2	PS attach / abnormal cases / access barred due to access class control / procedure 2
tc 12 2 1 7	PS attach / abnormal cases / change of cell into new routing area
tc 12 2 1 8	PS attach / abnormal cases / power off
tc 12 2 1 9	PS attach / abnormal cases / PS detach procedure collision
tc 12 2 2 1	Combined PS attach / PS and non-PS attach accepted
tc 12 2 2 2 1	Combined PS attach / PS only attach accepted / procedure 1
tc 12 2 2 2 2	Combined PS attach / PS only attach accepted / procedure 2
tc 12 2 2 3	Combined PS attach / PS attach while IMSI attach
tc 12 2 2 4	Combined PS attach / rejected / IMSI invalid / illegal ME
tc 12 2 2 5	Combined PS attach / rejected / PS services and non-PS services not allowed
tc 12 2 2 6	Combined PS attach / rejected / PS services not allowed
tc 12 2 2 7	Combined PS attach / rejected / location area not allowed
tc 12 2 2 8	Combined PS attach / abnormal cases / attempt counter check / miscellaneous reject causes
tc 12 2 2 9	Combined PS attach / abnormal cases / PS detach procedure collision
tc 12 3 1 1	PS detach (NMO II) / power off / accepted
tc 12 3 1 2	PS detach / accepted
tc 12 3 1 3	PS detach / accepted
tc 12 3 1 4	PS detach / abnormal cases / GMM common procedure collision
tc 12 3 1 5	PS detach (NMO I) / power off / accepted
tc 12 3 1 6	PS detach (NMO I) / accepted / PS/IMSI detach
tc 12 3 1 7	PS detach / accepted / IMSI detach
tc 12 3 1 8	PS detach / abnormal cases / GMM common procedure collision
tc 12 3 1 9	PS detach (NMO I) / abnormal cases / PS detach procedure collision
tc 12 3 2 1	Network initiated PS detach/ re-attach not required / accepted
tc 12 3 2 2	Network initiated PS detach/ re-attach not required / accepted
tc 12 3 2 3	Network initiated PS detach / IMSI detach / accepted
tc 12 3 2 4	Network initiated PS detach/ re-attach requested / accepted
tc 12 3 2 5	Network initiated PS detach / rejected / location area not allowed
tc 12 4 1 1	Routing area updating / accepted
tc 12 4 1 2	Routing area updating / rejected /IMSI invalid / illegal ME
tc 12 4 1 3	Routing area updating / rejected / UE identity cannot be derived by the network
tc 12 4 1 4	Routing area updating / rejected / location area not allowed
tc 12 4 1 5	Routing area updating / abnormal cases /attempt counter check / miscellaneous reject causes
tc 12 4 1 6	Routing area updating / abnormal cases / change of cell into new routing area
tc 12 4 1 7	Routing area updating / abnormal cases / change of cell during routing area procedure
tc 12 4 1 8	Routing area updating / abnormal cases / P-TMSI reallocation procedure collision
tc 12 4 2 1	Combined routing area updating / combined RA/LA accepted
tc 12 4 2 2	Combined routing area updating / UE in CS operation at change of RA
tc 12 4 2 9	Combined routing area updating / abnormal cases / change of cell during routing area procedure
tc 12 5	P-TMSI reallocation

tc_12_6_1_3_1	Authentication rejected by the UE / GMM cause 'MAC failure'
tc_12_6_1_3_2	Authentication rejected by the UE / GMM cause 'Synch failure'
tc_12_7	Identification procedure
tc_12_8	GMM READY timer handling
General Tests	
tc_13_2_1_1	Emergency call / with USIM / accept case
tc_13_2_2_1	Emergency call / without USIM / accept case
tc_13_2_2_2	Emergency call / without USIM / reject case
User Equipment features	
tc_17_1_2	Test of autocalling restrictions/ Constraining the access to a single number (TS 22.001 category 3)
tc_17_1_3	Test of autocalling restrictions/ Constraining the access to a single number (TS 22.001 category 1 and 2)
tc_17_1_4	Test of autocalling restrictions/ Behaviour of the UE when its list of blacklisted numbers is full

A.2.1 The TTCN Graphical form (TTCN.GR)

The TTCN.GR representation of this ATS is contained in an Adobe Portable Document Format™ file (nas.PDF contained in archive nas.ZIP) which accompanies the present document.

A.2.2 The TTCN Machine Processable form (TTCN.MP)

The TTCN.MP representation corresponding to this ATS is contained in an ASCII file (nas.MP contained in archive nas.ZIP) which accompanies the present document.

A.3 SMS ATS

The approved SMS test cases are listed.

Table A 2: NAS TTCN test cases

Test case	Description
tc_16_1_1	SMS point to point on CS mode / SMS mobile terminated
tc_16_1_2	SMS point to point on CS mode / SMS mobile originated
tc_16_1_3	SMS point to point on CS mode / Test of memory full condition and memory available notification
tc_16_1_4	SMS point to point on CS mode / Test of the status report capabilities and of SMS-COMMAND
tc_16_1_5_1	SMS point to point on CS mode / Test of class 0 short messages
tc_16_1_5_2	SMS point to point on CS mode / Test of class 1 short messages
tc_16_1_5_3	SMS point to point on CS mode / Test of class 2 short messages
tc_16_1_7	SMS point to point on CS mode / Test of the replace mechanism for SM type 1-7
tc_16_1_8	SMS point to point on CS mode / Test of the reply path scheme
tc_16_1_9_1	SMS point to point on CS mode / Multiple SMS mobile originated / UE in idle mode
tc_16_1_9_2	SMS point to point on CS mode / Multiple SMS mobile originated / UE in active mode
tc_16_3	Short message service cell broadcast

A.3.1 The TTCN Graphical form (TTCN.GR)

The TTCN.GR representation of this ATS is contained in an Adobe Portable Document Format™ file (sms.PDF contained in archive sms.ZIP) which accompanies the present document.

A.3.2 The TTCN Machine Processable form (TTCN.MP)

The TTCN.MP representation corresponding to this ATS is contained in an ASCII file (sms.MP contained in archive sms.ZIP) which accompanies the present document.

A.4 RRC ATS

The approved RRC test cases are listed.

Table A 3: RRC TTCN test cases

Test case	Description
tc_8_1_1_1	Paging for Connection in idle mode
tc_8_1_1_2	Paging for Connection in connected mode (CELL_DCH)
tc_8_1_1_3	Paging for Connection in connected mode (URA_PCH)
tc_8_1_1_4	Paging for Notification in idle mode
tc_8_1_1_5	Paging for Notification in connected mode (CELL_PCH)
tc_8_1_1_6	Paging for Notification in connected mode (URA_PCH)
tc_8_1_1_7	Paging for Notification in connected mode (CELL_DCH)
tc_8_1_1_8	Paging for Notification in connected mode (CELL_FACH)
tc_8_1_2_1	RRC Connection Establishment in CELL_DCH state: Success
tc_8_1_2_2	RRC Connection Establishment: Success after T300 timeout
tc_8_1_2_3	RRC Connection Establishment: Failure (V300 is greater than N300)
tc_8_1_2_4	RRC Connection Establishment: Reject ("wait time" is not equal to 0)
tc_8_1_2_5	RRC Connection Establishment: Reject ("wait time" is not equal to 0 and V300 is greater than N300)
tc_8_1_2_6	RRC Connection Establishment: Reject ("wait time" is set to 0)
tc_8_1_2_7	RRC Connection Establishment in CELL_FACH state: Success
tc_8_1_2_8	RRC Connection Establishment: Invalid system information message reception
tc_8_1_2_9	RRC Connection Establishment: Success after Physical
tc_8_1_3_1	RRC Connection Release in CELL_DCH state: Success
tc_8_1_3_2	RRC Connection Release in CELL_FACH state: Success
tc_8_1_3_3	RRC Connection Release using on CCCH in CELL_FACH state: Success
tc_8_1_3_4	RRC Connection Release in CELL_FACH state: Failure
tc_8_1_3_5	RRC Connection Release in CELL_FACH state: Invalid message
tc_8_1_5_1	UE Capability: Success
tc_8_1_5_2	UE Capability: Success after T304 timeout
tc_8_1_5_3	UE Capability in CELL_DCH state: Failure (After N304 retransmissions)
tc_8_1_5_4	UE Capability in CELL_DCH state: Success
tc_8_1_5_5	UE Capability in CELL_FACH state: Success after T304 timeout
tc_8_1_6_1	Direct Transfer in CELL_DCH state (invalid message reception)
tc_8_1_6_2	Direct Transfer in CELL_FACH state (invalid message reception)
tc_8_1_7_1	Security mode control in CELL_DCH state
tc_8_1_7_2	Security mode control in CELL_FACH state
tc_8_1_8_1	Counter check in CELL_DCH state
tc_8_1_8_2	Counter check in CELL_FACH state
tc_8_1_9_1	Signalling Connection Release Request
tc_8_2_1_1	Radio Bearer Establishment for transition from CELL_DCH to CELL_DCH: Success (Data integrity protection algorithm is not applied)
tc_8_2_1_2	RB Est. for transition from CELL_DCH to CELL_DCH: Success (Affected Data integrity protection algorithm)
tc_8_2_1_3	RB Est. for transition from CELL_DCH to CELL_DCH: Failure (Unsupported configuration)
tc_8_2_1_4	RB Est. for transition from CELL_DCH to CELL_DCH: Failure (Physical channel Failure and successful reversion to old configuration)
tc_8_2_1_6	RB Est. for transition from CELL_DCH to CELL_DCH: Failure (Incompatible simultaneous reconfiguration)
tc_8_2_1_7	RB Est. for transition from CELL_DCH to CELL_DCH: Failure (Invalid message reception)
tc_8_2_4_1	Transport channel reconfiguration from CELL_DCH to CELL_DCH (Hard handover to same radio frequency) Success with no transport channel type switching
tc_8_2_4_2	Transport channel reconfiguration from CELL_DCH to CELL_DCH: Failure (Unsupported configuration)
tc_8_2_4_3	Transport channel reconfiguration from CELL_DCH to CELL_DCH: Failure (Physical channel failure and reversion to old configuration)
tc_8_2_4_4	Transport channel reconfiguration from CELL_DCH to CELL_DCH: Failure (Physical channel failure and reversion failure)
tc_8_2_4_5	Transport Channel Reconfiguration from CELL_DCH to CELL_DCH: Failure (Incompatible simultaneous reconfiguration)
tc_8_2_4_6	Transport channel reconfiguration from CELL_DCH to CELL_DCH: Failure (Invalid message reception and

	Invalid configuration)
tc_8_2_4_7	Transport channel reconfiguration from CELL_DCH to CELL_FACH: Success
tc_8_2_4_9	Transport channel reconfiguration from CELL_DCH to CELL_FACH: Failure (Cell re-selection)
tc_8_2_4_10	Transport channel reconfiguration from CELL_FACH to CELL_DCH: Success
tc_8_2_4_11	Transport channel reconfiguration from CELL_FACH to CELL_DCH: Failure (Unsupported configuration)
tc_8_2_4_12	Transport channel reconfiguration from CELL_FACH to CELL_DCH: Failure (Physical channel failure and reversion to old channel)
tc_8_2_4_13	Transport channel reconfiguration from CELL_FACH to CELL_DCH: Failure (Physical channel failure and reversion failure)
tc_8_2_4_14	Transport Channel Reconfiguration from CELL_FACH to CELL_DCH: Failure (Incompatible simultaneous reconfiguration)
tc_8_2_4_15	Transport channel reconfiguration from CELL_FACH to CELL_DCH: Failure (Invalid message reception and Invalid configuration)
tc_8_2_4_16	Transport channel reconfiguration from CELL_FACH to CELL_FACH: Success with no transport channel type switching
tc_8_2_4_17	Transport channel reconfiguration from CELL_FACH to CELL_FACH: Failure (Cell re-selection)
tc_8_2_4_18	Transport Channel Reconfiguration from CELL_DCH to CELL_DCH: Success (Subsequently received)
tc_8_2_4_19	Transport Channel Reconfiguration from CELL_FACH to CELL_DCH: Success (Subsequently received)
tc_8_2_4_20	Transport Channel Reconfiguration from CELL_DCH to CELL_PCH: Success
tc_8_2_4_21	Transport Channel Reconfiguration from CELL_DCH to URA_PCH: Success
tc_8_2_5_1	Transport format combination control in CELL_DCH: restriction
tc_8_2_5_2	Transport format combination control in CELL_DCH: release a restriction
tc_8_2_5_3	Transport format combination control in CELL_DCH: Failure (Incompatible simultaneous reconfiguration)
tc_8_2_5_4	Transport format combination control in CELL_DCH: Failure (Invalid message reception and Invalid configuration)
tc_8_2_6_1	Physical channel reconfiguration for transition from CELL_DCH to CELL_DCH (Hard handover to another frequency): Success
tc_8_2_6_2	Physical channel reconfiguration for transition from CELL_DCH to CELL_DCH (Hard handover to another frequency): Failure (Unsupported configuration)
tc_8_2_6_3	Physical channel reconfiguration for transition from CELL_DCH to CELL_DCH (Hard handover to another frequency): Failure (Physical channel failure and reversion to old channel)
tc_8_2_6_4	Physical channel reconfiguration for transition from CELL_DCH to CELL_DCH (Hard handover to another frequency): Failure (Physical channel failure and reversion failure)
tc_8_2_6_5	Physical channel reconfiguration for transition from CELL_DCH to CELL_DCH (Hard handover to another frequency): Failure (Incompatible simultaneous reconfiguration)
tc_8_2_6_6	Physical channel reconfiguration for transition from CELL_DCH to CELL_DCH (Hard handover to another frequency): Failure (Invalid message reception and Invalid configuration)
tc_8_2_6_7	Physical channel reconfiguration for transition from CELL_DCH to CELL_FACH: Success
tc_8_2_6_8	Physical channel reconfiguration for transition from CELL_DCH to CELL_FACH: Failure (Cell re-selection)
tc_8_2_6_9	Physical channel reconfiguration for transition from CELL_FACH to CELL_DCH: Success
tc_8_2_6_10	Physical channel reconfiguration for transition from CELL_FACH to CELL_DCH: Failure (Unsupported configuration)
tc_8_2_6_11	Physical channel reconfiguration for transition from CELL_FACH to CELL_DCH: Failure (Physical channel failure and reversion to old configuration)
tc_8_2_6_12	Physical channel reconfiguration for transition from CELL_FACH to CELL_DCH: Failure (Physical channel failure and reversion failure)
tc_8_2_6_13	Physical channel reconfiguration for transition from CELL_FACH to CELL_DCH: Failure (Incompatible simultaneous reconfiguration)
tc_8_2_6_14	Physical channel reconfiguration for transition from CELL_FACH to CELL_DCH: Failure (Invalid message reception and Invalid configuration)
tc_8_2_6_15	Physical channel reconfiguration for transition from CELL_FACH to CELL_FACH (Hard handover to another frequency): Success
tc_8_2_6_16	Physical channel reconfiguration for transition from CELL_FACH to CELL_FACH: Failure (Cell re-selection)
tc_8_2_6_17	Physical channel reconfiguration for transition from CELL_DCH to CELL_DCH (Hard handover to another frequency): Success (Subsequently received)
tc_8_2_6_18	Physical channel reconfiguration for transition from CELL_FACH to CELL_DCH: Success (Subsequently received)
tc_8_2_6_19	Physical Channel Reconfiguration from CELL_DCH to CELL_PCH: Success
tc_8_2_6_20	Physical Channel Reconfiguration from CELL_DCH to URA_PCH: Success

tc_8_3_3_1	RNTI reallocation: Success
tc_8_3_3_2	RNTI reallocation: Failure (Invalid message reception)
tc_8_3_1_1	Cell Update: cell reselection in CELL_FACH
tc_8_3_1_2	Cell Update: cell reselection in CELL_PCH
tc_8_3_1_3	Cell Update: periodical cell update in CELL_FACH
tc_8_3_1_4	Cell Update: periodical cell update in CELL_PCH
tc_8_3_1_5	Cell Update: UL data transmission in URA_PCH
tc_8_3_1_6	Cell Update: UL data transmission in CELL_PCH
tc_8_3_1_7	Cell Update: paging response in URA_PCH
tc_8_3_1_8	Cell Update: Paging response in CELL_PCH
tc_8_3_1_9	Cell Update: re-entering of service area after T305 expiry and being out of service area
tc_8_3_1_10	Cell Update: expiry of T307 after T305 expiry and being out of service area
tc_8_3_1_11	Cell Update: Success after T302 time-out
tc_8_3_1_12	Cell Update: Failure (After Maximum Re-transmissions)
tc_8_3_1_13	Cell Update: Reception of Invalid CELL UPDATE CONFIRM Message
tc_8_3_1_15	Cell Update: Acknowledged Mode RLC Reset
tc_8_3_1_16	Cell Update: cell reselection in CELL_FACH
tc_8_3_1_17	Cell Update: Failure (UTRAN initiate an RRC connection release procedure on DCCH)
tc_8_3_1_18	Cell Update: Radio Link Failure (T314>0, T315=0)
tc_8_3_1_19	Cell Update: Unrecoverable error in RLC
tc_8_3_1_20	Cell Update: Reception of CELL UPDATE CONFIRM Message that causes invalid configuration
tc_8_3_2_1	URA Update: URA reselection
tc_8_3_2_2	URA Update: periodical URA update
tc_8_3_2_3	URA Update: re-entering of service area after T306 expiry
tc_8_3_2_4	URA Update: loss of service after expiry of timers T307 and T306
tc_8_3_2_5	URA Update: Success After Confirmation error of URA-ID list
tc_8_3_2_6	URA Update: Failure (V303 is greater than N303: Confirmation error of URA-ID list)
tc_8_3_2_7	URA Update: Success after T303 timeout
tc_8_3_2_8	URA Update: Failure (V303 is greater than N303: T303 timeout)
tc_8_3_2_9	URA Update: Failure (UTRAN initiate an RRC connection release procedure on DCCH)
tc_8_3_3_1	UTRAN Mobility Information: Success
tc_8_3_3_2	UTRAN Mobility Information: Failure (Invalid message reception)
tc_8_3_4_1	Active set update in soft handover: Radio Link Addition
tc_8_3_4_2	Active set update in soft handover: Radio Link Removal
tc_8_3_4_3	Active set update in soft handover: Combined radio link addition and removal (Active set is not full)
tc_8_3_4_4	Active set update in soft handover: Unsupported configuration in the UE
tc_8_3_4_5	Active set update in soft handover: Combined radio link addition and removal (Active set is full)
tc_8_3_4_6	Active set update in soft handover: Subsequent reception of ACTIVE SET UPDATE message/Incompatible simultaneous reconfiguration
tc_8_3_4_7	Active set update in soft handover: Invalid Message Reception
Radio Bearer Services	
tc_14_2_4	Conversational / speech / UL:12.2 DL:12.2 kbps / CS RAB + UL:3.4 DL:3.4 kbps SRBs for DCCH
tc_14_2_5	Conversational / speech / UL:10.2 DL:10.2 kbps / CS RAB + UL:3.4 DL: 3.4 kbps SRBs for DCCH
tc_14_2_6	Conversational / speech / UL:7.95 DL:7.95 kbps / CS RAB + UL:3.4 DL:3.4 kbps SRBs for DCCH
tc_14_2_7	Conversational / speech / UL:7.4 DL:7.4 kbps / CS RAB+ UL:3.4 DL:3.4 kbps SRBs for DCCH
tc_14_2_8	Conversational / speech / UL:6.7 DL:6.7 kbps / CS RAB + UL:3.4 DL:3.4 kbps SRBs for DCCH
tc_14_2_9	Conversational / speech / UL:5.9 DL:5.9 kbps / CS RAB + UL:3.4 DL:3.4 kbps SRBs for DCCH
tc_14_2_10	Conversational / speech / UL:5.15 DL:5.15 kbps / CS RAB + UL:1.7 DL:1.7 kbps SRBs for DCCH
tc_14_2_11	Conversational / speech / UL:4.75 DL:4.75 kbps / CS RAB + UL:1.7 DL:1.7 kbps SRBs for DCCH
tc_14_2_12	Conversational / unknown / UL:28.8 DL:28.8 kbps / CS RAB + UL:3.4 DL:3.4 kbps SRBs for DCCH
tc_14_2_13_1	Conversational / unknown / UL:64 DL:64 kbps / CS RAB + UL:3.4 DL:3.4 kbps SRBs for DCCH
tc_14_2_13_1	Conversational / unknown / UL:64 DL:64 kbps / CS RAB / 20 ms TTI

tc_14_2_13_2	Conversational / unknown / UL:64 DL:64 kbps / CS RAB + UL:3.4 DL:3.4 kbps SRBs for DCCH Conversational / unknown / UL:64 DL:64 kbps / CS RAB / 40 ms TTI
tc_14_2_14_1	Conversational / unknown / UL:32 DL:32 kbps / CS RAB + UL:3.4 DL:3.4 kbps SRBs for DCCH Conversational / unknown / UL:32 DL:32 kbps / CS RAB / 20 ms TTI
tc_14_2_14_2	Conversational / unknown / UL:32 DL:32 kbps / CS RAB + UL:3.4 DL:3.4 kbps SRBs for DCCH Conversational / unknown / UL:32 DL:32 kbps / CS RAB / 40 ms TTI
tc_14_2_15	Streaming / unknown / UL:14.4/DL:14.4 kbps / CS RAB + UL:3.4 DL:3.4 kbps SRBs for DCCH
tc_14_2_16	Streaming / unknown / UL:28.8/DL:28.8 kbps / CS RAB + UL:3.4 DL:3.4 kbps SRBs for DCCH
tc_14_2_17	Streaming / unknown / UL:57.6/DL:57.6 kbps / CS RAB + UL:3.4 DL:3.4 kbps SRBs for DCCH

A.4.1 The TTCN Graphical form (TTCN.GR)

The TTCN.GR representation of this ATS is contained in an Adobe Portable Document Format™ file (rrc.PDF contained in archive rrc.ZIP) which accompanies the present document.

A.4.2 The TTCN Machine Processable form (TTCN.MP)

The TTCN.MP representation corresponding to this ATS is contained in an ASCII file (rrc.MP contained in archive rrc.ZIP) which accompanies the present document.

A.5 RLC ATS

. The approved RRC test cases are listed.

Table A 4: RLC TTCN test cases

Test case	Description
tc_7_2_2_2	UM Segmentation and reassembly / Selection of 7 or 15 bit Length Indicators
tc_7_2_2_3	UM Segmentation / 7-bit Length Indicators / Padding
tc_7_2_2_4	UM Segmentation / 7-bit Length Indicators / LI = 0
tc_7_2_2_5	UM Segmentation / 7-bit Length Indicators / Invalid LI value
tc_7_2_2_6	UM Segmentation / 7-bit Length Indicators / LI value > PDU size
tc_7_2_2_7	UM Segmentation / 7-bit Length Indicators / First data octet LI
tc_7_2_2_8	UM Segmentation / 15-bit Length Indicators / Padding
tc_7_2_2_9	UM Segmentation / 15-bit Length Indicators / LI = 0
tc_7_2_2_10	UM Segmentation / 15-bit Length Indicators / One octet short LI
tc_7_2_2_11	UM Segmentation / 15-bit Length Indicators / LI value > PDU size
tc_7_2_2_12	UM Segmentation / 15-bit Length Indicators / First data octet LI
tc_7_2_3_2	AM Segmentation and reassembly / Selection of 7 or 15 bit Length Indicators
tc_7_2_3_3	AM Segmentation / 7-bit Length Indicators / Padding or Piggy-backed Status
tc_7_2_3_4	AM Segmentation / 7-bit Length Indicators / LI = 0
tc_7_2_3_5	AM Segmentation / 7-bit Length Indicators / Reserved LI value
tc_7_2_3_6	AM Segmentation / 7-bit Length Indicators / LI value > PDU size
tc_7_2_3_7	AM Segmentation / 15-bit Length Indicators / Padding or Piggy-backed Status
tc_7_2_3_8	AM Segmentation / 15-bit Length Indicators / LI = 0
tc_7_2_3_9	AM Segmentation / 15-bit Length Indicators / One octet short LI
tc_7_2_3_10	AM Segmentation / 15-bit Length Indicators / Reserved LI value
tc_7_2_3_11	AM Segmentation / 15-bit Length Indicators / LI value > PDU size
tc_7_2_3_12	AM Correct use of Sequence Numbering
tc_7_2_3_13	AM Control of Transmit Window
tc_7_2_3_14	AM Control of Receive Window
tc_7_2_3_15	AM Polling for status / Last PU in transmission queue
tc_7_2_3_16	Polling for status / Last PU in retransmission queue
tc_7_2_3_17	AM Polling for status / Poll every Poll_PU Pus
tc_7_2_3_18	Polling for status / Poll every Poll_SDU SDUs
tc_7_2_3_19	AM Polling for status / Timer triggered polling (Timer_Poll_Periodic)
tc_7_2_3_20	AM Polling for status / Polling on Poll_Window% of transmission window
tc_7_2_3_21	AM Polling for status / Operation of Timer_Poll timer / Timer expiry
tc_7_2_3_22	AM Polling for status / Operation of Timer_Poll timer / Stopping Timer_Poll timer
tc_7_2_3_23	AM Polling for status / Operation of Timer_Poll timer / Restart of the Timer_Poll timer
tc_7_2_3_24	AM Polling for status / Operation of timer Timer_Poll_Prohibit
tc_7_2_3_25	AM Receiver Status Triggers / Detection of missing Pus
tc_7_2_3_26	AM Receiver Status Triggers / Operation of timer Timer_Status_Periodic
tc_7_2_3_27	AM Receiver Status Triggers / Operation of timer Timer_Status_Prohibit
tc_7_2_3_28	AM Status reporting / Abnormal conditions / Reception of LIST SUFI with Length set to zero
tc_7_2_3_30	AM SDU discard after MaxDAT number of retransmissions
tc_7_2_3_31	AM Timer based discard, with explicit signalling / Failure of MRW procedure
tc_7_2_3_32	AM SDU discard after MaxDAT number of retransmissions
tc_7_2_3_33	AM Operation of the RLC Reset procedure / UE Originated
tc_7_2_3_34	AM Operation of the RLC Reset procedure / UE Terminated

A.5.1 The TTCN Graphical form (TTCN.GR)

The TTCN.GR representation of this ATS is contained in an Adobe Portable Document Format™ file (rlc.PDF contained in archive rlc.ZIP) which accompanies the present document.

A.5.2 The TTCN Machine Processable form (TTCN.MP)

The TTCN.MP representation corresponding to this ATS is contained in an ASCII file (rlc.MP contained in archive rlc.ZIP) which accompanies the present document.

A.6 MAC ATS

tbd

A.7 BMC ATS

tbd

A.8 PDCP ATS

Tbd

Annex B (normative): Partial IXIT proforma

Notwithstanding the provisions of the copyright clause related to the text of the present document, [tbd] grants that users of the present document may freely reproduce the <proformatype> proforma in this {clause annex} so that it can be used for its intended purposes and may further publish the completed <proformatype>.
--

B.0 Introduction

This partial IXIT proforma contained in the present document is provided for completion, when the related Abstract Test Suite is to be used against the Implementation Under Test (IUT).

Text in *italics* is comments for guidance for the production of a IXIT, and is not to be included in the actual IXIT.

The completed partial IXIT will normally be used in conjunction with the completed ICS, as it adds precision to the information provided by the ICS.

B.1 Parameter values

B.1.1 L2M Test Suite Parameter Declarations

The following parameters are common to all ATs.

Table B1: L2M PIXIT

Parameter Name	Description	Type	Default Value	Supported Value
px_Auth_n	Value of n to initialize tcv_Auth_n (length of extended response) min 31, max 127 (TS 34.108 cl. 8.1.2)	INTEGER	3127	
px_AuthAMF	Authentication Management Field (16 bits). <u>The value shall be different from '1111 1111 1111 1111'B (AMFresynch).</u>	BITSTRING	See note 2	
px_AuthK	Authentication Key (128 bits)	BITSTRING	'01011110010010101010011001101010000001001000000100101100110011001100001100010011010011000101001'B	
px_AuthRAND	Random Challenge (128 bits)	BITSTRING	'01010101...01'B	
px_CiphAlgCap	Ciphering Algorithm Capability	B16	'0000000000000001'B	
px_CipheringAlgorithm	Ciphering Algorithm uea0 - 0, uea1 - 1, ...	CipheringAlgorithm	0	
px_CipheringOnOff	Security mode - TRUE if ciphering is applicable	BOOLEAN	FALSE	
px_CodeNumAICH	Channelization code number for AICH (spreading factor is 256), default value = 255 (from default SIB5)	INTEGER	255	
px_CodeNumberPICH	Channelization code for PICH, the spreading factor is 256, default value = 255 (from default SIB5)	ChannelisationCode256	255	
px_CRNTI	C RNTI	C_RNTI	'0000 0000 0000 0001'B	
px_CS	TRUE if Circuit Switched is applicable	BOOLEAN	TRUE	
px_DL_TxPower_DPCH_4_22AMR	Down link transmit power level of DPCH used for 12.2 kbps AMR	DL_TxPower	-5	
px_DL_TxPower_DPCH_3_4_StandAlone	Downlink transmission power level of DPCH used for 3.4 kbps stand-alone SRB	DL_TxPower	5	
px_DL_TxPower_DPCH_6_4K	Down link transmission power level of DPCH used for 64 kbps PS SRB	DL_TxPower	5	
px_FRESH	Value for FRESH	Fresh	See note 1	
px_IMEI_Def	Default IMEI value	HEXSTRING	See note 1	
px_IMEISV_Def	Default IMEISV value	HEXSTRING	See note 1	
px_IMSI_Def	Default IMSI value	HEXSTRING	'001010123456063'H	
px_IMSI_Diff	Different IMSI from the IMSI stored in the USIM	HEXSTRING	'001010654321063'H	
px_IntegrityOnOff	Integrity mode – TRUE if integrity is applicable	BOOLEAN	FALSE	

px_IntegrityProtectInitNumber	Integrity Protect Initial Number	IntegrityProtInitNumber	See note 1	
px_KeySeqDef	Default Key Sequence	Keyseq	'101'B	
px_MA_Code	Message Authentication Code (32) MAC-I	MessageAuthenticatiCode	See note 1	
px_MSCIsmk_A5_1	Default Algorithm A5/1 supported	B1	'0'B	
px_MSCIsmk_ESIND	Default Early Sending Indication	B1	'0'B	
px_MSCIsmk_RevLvl	Default Revision Level	B2	'10'B	
px_MSCIsmk_RF_PwrCap	Default RF Power Capability	B3	'000'B	
px_NMO	This parameter is used to specify network operation mode. Valid values: '00'O and '01'O	OCTETSTRING	'00'O	
px_PowerAICH	Transmission power level of AICH	DL_TxPower	-5	
px_PowerpCCPCH	Transmission power level of primary CCPCH	DL_TxPower	-2	
px_PowerpCPICH	Transmission power level of primary CPICH	DL_TxPower_PCPICH	-60	
px_PowerpCPICH_A	Transmission power level of primary CPICH (for the default Cell A)	DL_TxPower_PCPICH	-60	
px_PowerPICH	Transmission power level of primary PICH	DL_TxPower	-5	
px_PowerpSCH	Transmission power level of primary SCH	DL_TxPower	-5	
px_PowersCCPCH1	Transmission power level of secondary CCPCH1	DL_TxPower	-2	
px_PowersSCH	Transmission power level of secondary SCH	DL_TxPower	-5	
px_PriScrmCodeA	Primary scrambling code (for the default Cell A)	PrimaryScramblingCode	100	
px_PriScrmCodeB	Primary scrambling code (for the default Cell B)	PrimaryScramblingCode	110	
px_PriScrmCodeC	Primary scrambling code (for the default Cell C)	PrimaryScramblingCode	120	
px_PriScrmCodeD	Primary scrambling code (for the default Cell D)	PrimaryScramblingCode	130	
px_PriScrmCodeE	Primary scrambling code (for the default Cell E)	PrimaryScramblingCode	140	
px_PriScrmCodeF	Primary scrambling code (for the default Cell F)	PrimaryScramblingCode	150	
px_PS	TRUE if Packet Switched is applicable	BOOLEAN	TRUE	
px_PTMSI_Def	default PTMSI	OCTETSTRING	'12345678'O	
px_PTMSI_Sig_Def	default PTMSI signature (3 octets, 3GPP 24.008 / 10.5.5.8)	OCTETSTRING	'AB123466'O	
px_PuncLimit	Puncturing limit for PRACH	PuncturingLimit	PI1	
px_RAC	This parameter is used to specify routing arear code, valid length of the octetstring is 2.	OCTETSTRING		
px_RAT	This parameter is used to specify which radio access technology is being used for the current test execution. Valid values: fdd and tdd	RatType	fdd	
px_RB_ConfigType	Type of Radio Access Bearer to be established	RB_ConfigType	DCCH_3_4k	
px_Region	This parameter is used to specify for which region the system information blocks are broadcast in the test execution. Valid values: "Japan" and "Europe".	Region	"Europe"	
px_SF_Pilot_Code	Code of the Spread Fact and Pilot of	INTEGER	4	

	Downlink information common for all radio links. If the code is 'sf4' then the value of this pixit shall be 4.			
px_SF_Pilot_Size	Size of the Spread Fact and Pilot of Downlink information common for all radio links. Used for sfd128 and sfd256.	PilotBits128	pb4	
px_SF_PRACH	Spreading factor for PRACH	SF_PRACH	Sfpr64	
px_SF512_Code	Code of the Spread Factor and Code Number in downlink DPCH information per radio link code list, see constraint "cb_DL_InformationPerRL". If the code is 'sf4' then the value of this pixit shall be 4.	INTEGER	4	
px_SF512_Size	Size of the Spread Factor and Code Number in downlink DPCH information per radio link code list, see constraint "cb_DL_InformationPerRL"	INTEGER	3	
px_SlotFormatsCCPCH1	Channelization code for secondary CCPCH1 when spreading factor = 64	SCCPCHSlotFormat	4	
px_SndScrmCodeAICH	Secondary scrambling code for AICH channel, default value = 1(from default SIB5)	INTEGER	1	
px_SndScrmCodePICH	Secondary scrambling code for PICH channel, default value =2 (from default SIB5)	INTEGER	2	
px_SprdFct	Spread Fact of uplink DPCH info, see constraint " cb_UI_DpchInfo"	SpreadingFactor	sf16	
px_SRNC_Id	SRNC Id	SRNC_Identity	'0000 0000 0001'B	
px_SRNC_IdDiff	Different value for SRNC Id than in px_SRNCId	SRNC_Identity	'0000 0000 0010'B	
px_SRNTI	S RNTI	S_RNTI	'0000 0000 0000 0000 0001'B	
px_SRNTI_Diff	Different value for S RNTI than in px_SRNTI	S_RNTI	'0000 0000 0000 0000 0010'B	
px_TcellA	Timing offset between BFN and SCH (for the default Cell A)	Tcell	0	
px_TcellATcellB	Timing offset between BFN and SCH (for the default Cell BA)	Tcell	02	
px_Tcell_2ndCell	Timing offset between BFN and SCH (for the second Cell)	Tcell	1	
px_TimingsCCPCH1	Timing offset for secondary CCPCH1	INTEGER	0	
px_TMSI_Def	Default TMSI	OCTETSTRING	'12345678'O	
px_UARFCN_D_A	Default value = px_UARFCNu + 950 (for the default Cell A)	INTEGER	10700	
px_UARFCN_D_A_New	default value = px_UARFCNu + 950 on cell A	INTEGER	10650	
px_UARFCN_U_A	Uplink UARFCN number, default value = 9750 (for the default Cell:A)	INTEGER	9750	
px_UARFCN_U_A_New	uplink UARFCN number, default value = 9750 on cell A	INTEGER	9700	
px_UE_OpModeDef	Default UE operation mode (either opModeA or opModeC). (For most UEs this corresponds class-A or class-C, and can not be changed by the user)	UE_OperationMode	opModeA	
NOTE 1: No default value can be proposed (Manufacturer defined value).				
NOTE 2: No default value can be proposed, because not enough information is available in TS34.109 clause 8.1.2.				

B.1.2 L3M Test Suite Parameters Declarations

The following parameters are commonly used in the RRC and NAS ATSS.

Table B2: L3M PIXIT

Parameter Name	Description	Type	Default Value	Supported Value
px_AccessPt_Name	The logical name for the GGSN or the external packet world	IA5String	"ABCDEF"	
px_AddrInfo	A string parameter that identifies the MT in the address space applicable to the PDP.	IA5String	"200.1.1.80"	
px_BcapDataCompression	Data compression supported (used in the Bearer Capability)	B1	'0'B	
px_BcapFNUR	Fixed Network User rate supported: '00001'B: FNUR 9.6 kbit/s '00010'B: FNUR 14.4 kbit/s '00011'B: FNUR 19.2 kbit/s '00100'B: FNUR 28.8 kbit/s '00101'B: FNUR 38.4 kbit/s '00110'B: FNUR 48.0 kbit/s '00111'B: FNUR 56.0 kbit/s '01000'B: FNUR 64.0 kbit/s '01001'B: FNUR 33.6 kbit/s '01010'B: FNUR 32.0 kbit/s	B5	'00001'B	
px_BcapITC	Information transfer capability supported (used for the generation of the Bearer Capability) 0 - UDI 1 - RDI 2 - 31 kHz Audio 3 - Other	Itclnt	2	
px_BcapModemType	Modem type supported (used in the Bearer Capability)	B5	'00110'B	
px_BcapNumberDataBits	Number of data bits supported (used in the Bearer Capability)	B1	8	
px_BcapNumberStopBits	Number of Stops bits supported (used in the Bearer Capability)	B1	2	
px_BcapOtherModemType	Other modem type supported (used in the Bearer Capability)	B2	'10'B	
px_BcapParity	Parity supported (used in the Bearer Capability)	B3	'011'B	
px_BcapSACP	Signalling access protocol supported (used in the Bearer Capability)	B3	'001'B	
px_BcapSyncAsync	Synchronous '0'B or Asynchronous '1'B mode supported by IUT	B1	'1'B	
px_BcapUeFlowControl	UE flow control. 0-outband, 1-inband, 2-no flow control. 3- X.25 4- X.75 Default: 0, outband flow control	FlowControl	0	
px_CC_CallDiallingDigits	Dialling digits used to initiate a CC MO call	IA5String	"0123456902"	
px_CC_Serv	Service selected for Mobile Originated calls and Mobile Terminated calls. The possible values are ("Telephony", "EmergencyCall", "31kHz", "V110", "V120", "PIAFS", "FTM", "X31", "BTM", "MmediaCall")	Services	"31kHz"	
px_MS_Cismk_A5_2	Default Algorithm A5/2 supported	B1	'0'B	
px_MS_Cismk_A5_3	Default Algorithm A5/3 supported	B1	'0'B	
px_MS_Cismk_CM3	Default Classmark 3 Indicator	B1	'0'B	

px_MS_Clsmk_CMSP	Default CM Service Prompt Support	B1	'0'B	
px_MS_Clsmk_FreqCap	Default Frequency Capability	B1	'0'B	
px_MS_Clsmk_LCSVA_Cap	Default LCSVA Capabilities Support	B1	'0'B	
px_MS_Clsmk_PS_Cap	Default Pseudo Synchronisation Capability	B1	'0'B	
px_MS_Clsmk_SM_Cap	Default Short Message Capability	B1	'1'B	
px_MS_Clsmk_SoLSA	Default SoLSA supported	B1	'0'B	
px_MS_Clsmk_SSSI	Default SS Screen Indicator	B2	'01'B	
px_MS_Clsmk_UCS2	Default UCS2 encoding supported	B1	'0'B	
px_MS_Clsmk_VBS	Default VBS Capability	B1	'0'B	
px_MS_Clsmk_VGCS	Default VGCS Capability	B1	'0'B	
px_PDP_TypeNo	Indicates IP v4 or IP v6	PDP_TypeNo	'00100001'O	
px_PDP_TypeOrg	A string parameter which specifies the type of packet data protocol	B4	'0000'B	
px_PriScrmCodeB	Primary scrambling code for Cell B	PrimaryScramblingCode	150	
px_TcellB	Timing offset between BFN and SCH Cell B	Tcell	0	
px_UARFCN_D_B	RF frequency number for downlink Cell B	INTEGER	10650	
px_UARFCN_U_B	RF frequency number for uplink Cell B	INTEGER	9700	

B.1.3 NAS Test Suite Parameters Declarations

The following parameters are commonly used in the NAS ATS.

Table B3: NAS PIXIT

Parameter Name	Description	Type	Default Value	Supported Value
px_AuthRAND_2	A second Random Challenge (128 bits)	BITSTRING	'1010101...10'B	
px_AutocallingBlacklistNumber	Number of B-party numbers that can be stored in the list of blacklisted numbers	INTEGER	20	
px_AutocallingCause1or2	Cause value of category 1 or 2 to be used in TC_17_1_3	INTEGER	18	
px_AutocallingNumber	Called number to be used for autocalling	IA5String	"0613454120"	
px_AutocallingRepeatCategory2	Number of repeat attempt done for the category 1 or 2 to be used in TC_17_1_3	INTEGER	10	
px_CC_ServNotSupp	Not supported service selected for Mobile Originated calls and Mobile Terminated calls. The possible values are ("Telephony", "EmergencyCall", "31kHz", "V110", "V120", "PIAFS", "FTM", "X31", "BTM", "MmediaCall")	Services	"BTM"	
px_DTMF_BasicCharSet	TRUE if DTMF Chars 0-9, *, # supported	BOOLEAN	TRUE	
px_DTMF_OtherCharSet	TRUE if DTMF Chars A, B, C, D supported	BOOLEAN	TRUE	
px_DTMF_ToneInd	TRUE if UE support DTMF tone indication	BOOLEAN	TRUE	
px_KeySeq2	Second key sequence	KeySeq	'000'B	
px_NoNwOrgPDP_ContextSupp	This indicates the number of network originated PDP context supported by the UE	INTEGER (0..7)	7	
px_NwOrgPDP_Support	This indicates if the UE implementation supports network originated PDP Context	BOOLEAN	TRUE	
px_PriScrmCodeC	Primary scrambling code for Cell C	PrimaryScramblingCode	200	
px_PTMSI_Sig_Def	Default P-TMSI signature. Default :	OCTETSTRING	'AB123466'O	
px_TcellC	Timing offset between BFN and SCH Cell C	Tcell	0	
px_TMSI_2	Second TMSI value	OCTETSTRING	'09876543'O	
px_UARFCN_D_C	RF frequency number for downlink Cell C	INTEGER	10750	
px_UARFCN_U_C	RF frequency number for uplink Cell C	INTEGER	9800	
px_UuInfo	User-user information for TC 10_3	OCTETSTRING	'01020304'O	
px_Uupd	User-user protocol discriminator for TC 10_3	B8	'00000100'B	

B.1.4 SMS Test Suite Parameters Declarations

These parameters are used in the SMS ATS.

Table B4: SMS PIXIT

Parameter Name	Description	Type	Default Value	Supported Value
px_BMC_CB_RepPeriod01	CB repetition period for CB message 1	INTEGER	2	
px_BMC_CB_RepPeriod02	CB repetition period for CB message 2	INTEGER	2	
px_BMC_NoOfBC_Req01	No of broadcasts requested for CB message 1	INTEGER	2	
px_BMC_NoOfBC_Req02	No of broadcasts requested for CB message 2	INTEGER	2	
px_MaxCP_DataRetx	max. number of CP data retransmissions for SMS	INTEGER	3	
px_SMS_CB_Data01	Contents of the first Cell Broadcast Message sent will be converted to an OCTETSTRING	IA5String	"First Cell Broadcast Message"	
px_SMS_CB_Data02	Contents of the second Cell Broadcast Message sent will be converted to an OCTETSTRING	IA5String	"Second Cell Broadcast Message"	
px_SMS_CB_MsgId01	Message Id to be used for the first Cell Broadcast Message sent	B16	'0000000000000001'B	
px_SMS_CB_MsgId02	Message Id to be used for the second Cell Broadcast Message sent	B16	'0000000000000010'B	
px_TC1M	Value for timer TC1M, to be declared by the manufacturer	INTEGER	10000	

B.1.5 RRC Test Suite Parameters Declarations

These parameters are used in the RRC ATS.

Table B5: RRC PIXIT

Parameter Name	Description	Type	Default Value	Supported Value
px_RB_DataConversational_14_4	Data to be sent for RB test TC_14_2_15	BITSTRING	INT TO BIT (2473304159874, 563214258, 576) '00000000000000000000000000000000'B	
px_RB_DataConversational_28_8	Data to be sent for RB test TC_14_2_12	BITSTRING	INT TO BIT (5896632514789, 5411444477884, 54777, 1152) '00000000000000000000000000000000'B	
px_RB_DataConversational_32	Data to be sent for RB test TC_14_2_14	BITSTRING	INT TO BIT (1245789632541, 2455548851232, 3565565465, 1280) '00000000000000000000000000000000'B	
px_RB_DataConversational_64	Data to be sent for RB test TC_14_2_13	BITSTRING	INT TO BIT (8941203214580, 9654789322116, 84654654, 2560) '00000000000000000000000000000000'B	
px_RB_DataSpeech_10_2	Data to be sent for RB test TC_14_2_5	BITSTRING	INT TO BIT (123456789, 99) '00000000000000000000000000000000'B	
px_RB_DataSpeech_12_2	Data to be sent for RB test TC_14_2_4	BITSTRING	INT TO BIT (1589642321313, 2132, 103) '00000000000000000000000000000000'B	
px_RB_DataSpeech_4_75	Data to be sent for RB test TC_14_2_11	BITSTRING	INT TO BIT (9007195689745, 888, 53) '00000000000000000000000000000000'B	
px_RB_DataSpeech_5_15	Data to be sent for RB test TC_14_2_10	BITSTRING	INT TO BIT (1523402589632, 104555, 54) '00000000000000000000000000000000'B	
px_RB_DataSpeech_5_9	Data to be sent for RB test TC_14_2_9	BITSTRING	INT TO BIT (1234564787987, 987901247, 64) '00000000000000000000000000000000'B	
px_RB_DataSpeech_6_7	Data to be sent for RB test TC_14_2_8	BITSTRING	INT TO BIT (2589647589645, 46546546, 76) '00000000000000000000000000000000'B	
px_RB_DataSpeech_7_4	Data to be sent for RB test TC_14_2_7	BITSTRING	INT TO BIT (7894561234560, 4, 87)	

			'00000000000000 000000000000'B
px_RB_DataSpeech_7_95	Data to be sent for RB test TC_14_2_6	BITSTRING	INT_TO_BIT (9876542569874 56987455, 84) '00000000000000 000000000000'B
px_RB_DataStreaming_28_8	Data to be sent for RB test TC_14_2_16	BITSTRING	INT_TO_BIT (1238974566954 1023154687546 5465465465465 4, 1152) '00000000000000 000000000000'B
px_RB_DataStreaming_57_6	Data to be sent for RB test TC_14_2_17	BITSTRING	INT_TO_BIT (1235898745698 7465213213265 0, 2304) '00000000000000 000000000000'B

B.1.5 MMI questions

The table below shows the list of MMI questions used in the ATs, the column 'ATS' indicates in which ATS the question is used.

Table B5: MMI questions

MMI question	ATS
How to switch the PLMN selection mode of the UE to automatic selection? NOTE: Used in the step ts_MMI_PLMN_SelModeAuto	All ATs
How to switch the PLMN selection mode of the UE to manual selection? NOTE: Used in the step ts_MMI_PLMN_SelModeMan	All ATs
How to select a given PLMN manually? NOTE: Used in the step ts_MMI_PLMN_SelPerf	All ATs
How to power off the UE?	All ATs

NOTE: Used in the step ts_MMI_UE_PwrOff	
How to power on the UE? NOTE: Used in the step ts_MMI_UE_PwrOn	All ATs
How to switch off the UE? NOTE: Used in the step ts_MMI_UE_SwitchOff	All ATs
How to switch on the UE? NOTE: Used in the step ts_MMI_UE_SwitchOn	All ATs
How to insert the USIM card into the UE? NOTE: Used in the step ts_MMI_USIM_Insert	All ATs
How to remove the USIM card from the UE? NOTE: Used in the step ts_MMI_USIM_Remove	All ATs
How to check that DTCH is trough connected ? NOTE: Used in steps ts_MMI_CheckDTCH_ThroughConnected and ts_UT_DTCH_NotthroughConnected	RRC, SMS, NAS
How to configure UE for a MO telephony call?	RRC, SMS, NAS

NOTE: Used in the step ts_MMI_ConfigUE_MO	
How to configure UE for an emergency call? NOTE: Used in the step ts_MMI_ConfigUE_MO	RRC, SMS, NAS
How to configure UE for a MT telephony call? NOTE: Used in the step ts_MMI_ConfigUE_MT	RRC, SMS, NAS
How to send any NAS message in order for RRC to receive data? NOTE: Used in the step ts_MMI_SendData	RRC, SMS, NAS
How to initiate a non call related supplementary service which is supported by the UE? NOTE: Used in the step ts_MMI_InitNonCallRelSS	NAS
How to initiate sending of a mobile originated short message from the UE? NOTE: Used in the step ts_MMI_InitSMS_MO	NAS
How to insert 2 nd SIM card with short IMSI? NOTE: Used in the step ts_MMI_USIM2_Insert	NAS
How to initiate an autocalling call with a given number?	NAS

NOTE: Used in the step ts_MMI_AutocallingInitCall	
How to initiate an autocalling call for a number that will be put in the blacklisted list? NOTE: Used in the step ts_MMI_AutocallingInitCall_BlackList	NAS
How to reset the autocalling list of blacklisted numbers? NOTE: Used in the step ts_MMI_AutocallingresetBlacklist	NAS
How to check that the DTMF tone indication has been generated? NOTE: Used in the step ts_MMI_DTMF_CheckTone	NAS
How to enable call refusal on the UE? NOTE: Used in the step ts_MMI_EnableCallRefusal	NAS
How to check the contents of the received CBS? NOTE: Used in the step ts_MMI_ChkCBS_Received	SMS
How to check that the Memory Capacity Exceeded Flag has been set to the USIM simulator? NOTE: Used in the step ts_MMI_ChkMCEF_Set	SMS
How to check if the Memory Capacity Exceeded Flag has been unset on the USIM simulator?	SMS

NOTE: Used in the step ts_MMI_ChkMCEF_Unset	
How to check the length and the contents of a given received Short Message ? NOTE: Used in the step ts_MMI_ChkMsgDisplayed	SMS
How to check whether the USIM simulator indicated an attempt made by the ME to store the short message in the USIM and return the status response 'Memory Problem'('92 40')? NOTE: Used in the step ts_MMI_ChkUSIM_AttnMemProblem	SMS
How to check whether the USIM simulator indicates an attempt made by the ME to store the short message in the USIM and returns the status response 'OK' ('90 00')? NOTE: Used in the step ts_MMI_ChkUSIM_AttnOK	SMS
How to connect the USIM simulator to the UE? NOTE: Used in the step ts_MMI_ConnectUSIM_Simulator	SMS
How to send an SMS COMMAND message containing a request to delete the previously submitted Short Message? NOTE: Used in the step ts_MMI_InitSMS_CmdDel	SMS
How to send an SMS COMMAND message containing an enquiry about the previously submitted SM?	SMS

NOTE: Used in the step ts_MMI_InitSMS_CmdEnq	
How to check that NO recalled short Message is displayed? NOTE: Used in the step ts_MMI_RecallAndNotDisplay	SMS
How to reply to a short Message with a given length? NOTE: Used in the step ts_MMI_SM_Reply	SMS

Annex C (informative): Additional information to IXIT

Additional information may be provided when completing the IXIT questions listed in annex A.

C.1 Identification Summary

This table is completed by the test laboratory. The item "Contract References" is optional.

Table C1: Identification Summary

IXIT Reference Number	
Test Laboratory Name	
Date of Issue	
Issued to (name of client)	
Contract References	

C.2 Abstract Test Suite Summary

In the following table the test laboratory provides the version number of the protocol specification and the version number of ATS which are used in the conformance testing.

Table C2: ATS Summary

Protocol Specification	TS 25.331
Version of Protocol Specification	
Test Specification in prose	TS 34.123-1
Version of TSS & TP Specification	
ATS Specification	TS 34.123-3
Version of ATS Specification	
Abstract Test Method	Distributed Test Method

C.3 Test Laboratory

C.3.1 Test Laboratory Identification

The test laboratory provides the following information.

Table C3: Test Laboratory Identification

Name of Test Laboratory	
Postal Address	
Office address	
e-mail address	
Telephone Number	
FAX Number	

C.3.2 Accreditation status of the test service

The test laboratory provides the following information.

Table C4: Accreditation status of the test service

Accreditation status	
Accreditation Reference	

C.3.3 Manager of Test Laboratory

The test laboratory provides the information about the manager of test laboratory in the following table.

Table C5: Manager of Test Laboratory

Name of Manager of Test Laboratory	
e-mail address	
Telephone Number	
FAX Number	
E-mail Address	

C.3.4 Contact person of Test Laboratory

The test laboratory provides the information about the contact person of test laboratory in the following table.

Table C6: Contact person of Test Laboratory

Name of Contact of Test Laboratory	
e-mail address	
Telephone Number	
FAX Number	
E-mail Address	

C.3.5 Means of Testing

In the table below, the test laboratory provides a statement of conformance of the Means Of Testing (MOT) to the reference standardized ATS, and identifies all restrictions for the test execution required by the MOT beyond those stated in the reference standardized ATS.

Table C7: Means of Testing

Means of Testing

C.3.6 Instructions for Completion

In this table, the test laboratory provides any specific instructions necessary for completion and return of the proforma from the client.

Table C8: Instruction for Completion

Instructions for Completion

C.4 Client

C.4.1 Client Identification

The client provides the identification in the following table.

Table C9: Client Identification

Name of Client	
Postal Address	
Office Address	
Telephone Number	
FAX Number	

C.4.2 Client Test Manager

In this table the client provides information about the test manager.

Table C10: Client Test Manager

Name of Client Test Manager	
Telephone Number	
FAX Number	
E-mail Address	

C.4.3 Client Contact person

In this table the client provides information about the test contact person.

Table C11: Client Contact person

Name of Client contact person	
Telephone Number	
FAX Number	
E-mail Address	

C.4.4 Test Facilities Required

In the following table, the client records the particular facilities required for testing, if a range of facilities is provided by the test laboratory.

Table C12: Test Facilities Required

Test Facilities Required

C.5 System Under Test

C.5.1 SUT Information

The client provides information about the SUT in the table below.

Table C13: SUT Information

System Name	
System Version	
SCS Reference	
Machine Configuration	
Operating System Identification	
IUT Identification	
ICS Reference for the IUT	

C.5.2 Limitations of the SUT

In the table below, the client provides information explaining if any of the abstract tests cannot be executed.

Table C14: Limitation of the SUT

Limitations of the SUT

C.5.3 Environmental Conditions

In the table below the client provides information about any tighter environmental conditions for the correct operation of the SUT.

Table C15: Environmental Conditions

Environmental Conditions

C.6 Ancillary Protocols

This clause is completed by the client in conjunction with the test laboratory.

In the following tables, the client identifies relevant information concerning each ancillary protocol in the SUT other than the IUT itself. One table for one ancillary protocol.

Based on the MOT the test laboratory should create question proforma for each ancillary protocol in the blank space following each table. The information required is dependent on the MOT and the SUT, and covers all the addressing, parameter values, timer values and facilities (relevant to ENs) as defined by the ICS for the ancillary protocol.

C.6.1 Ancillary Protocols 1

Table C16: Ancillary Protocol 1

Protocol Name	
Version number	
ICS Reference (optional)	
IXIT Reference (optional)	
PCTR Reference (optional)	

C.6.2 Ancillary Protocols 2

Table C17: Ancillary Protocol 2

Protocol Name	
Version number	
ICS Reference (optional)	
IXIT Reference (optional)	
PCTR Reference (optional)	

Annex D (informative): PCTR Proforma

Notwithstanding the provisions of the copyright clause related to the text of this ETS, ETSI grants that users of this ETS may freely reproduce the PCTR proforma in this annex so that it can be used for its intended purposes and may further publish the completed PCTR.

PROTOCOL

Conformance Test Report

(PCTR)

Universal Mobile Telecommunication System, UMTS,
User Equipment-Network Access

Layer 3 Signalling Functions

Test Candidate	
Name :	SUT name
Model :	model
H/W version :	hw
S/W version :	sw
Serial No. :	serienr

Client	
Name :	
Street / No. :	
Postal Code / City:	
Country :	

This Test Report shall not be reproduced except in full without the written permission of TEST LAB REFERENCE, and shall not be quoted out of context.

Annex E (informative): TTCN style guide for 3GPP ATS

E.1 Introduction

This annex provides a set of coding standards and development guidelines for use in the development of TTCN abstract test suites for ensuring that user equipment for the 3GPP standard conforms to the relevant core specifications.

The following items are assumed to exist, but their specification is outside the scope of this annex.

- A complete unambiguous prose detailing all test cases to be implemented,
- A complete unambiguous set of core specifications,
- A complete unambiguous detailed description of all the messages that are to be sent,
- A tool or human process that can convert Test Suite Operation Definitions to physical processes within the test system or unit under test,
- An abstracted or generic application programmers interface to all hardware components in the system,
- A tool for the translation and/or compilation of ISO/IEC 9646 series TTCN to run on a test platform.

It is recognised within the context of the 3GPP User Terminal that some of these items are not yet stabilised.

The structure of the present annex maps directly to the guidelines provided in ETR 141. Rules are repeated in the present annex for convenience, with additional information specific to 3GPP test suite development provided where relevant. For more detailed information or examples about the rules, see ETR 141.

In the present annex, the terms 'should' and 'shall' are frequently used. For the purpose of this annex, the following definitions apply:

Shall means that the rule must be adhered to for all ATS development. If a rule expressed in terms of 'shall' is not followed, either the ATS must be updated so that the rule is followed, or the rule in the coding conventions must be updated to resolve the difference.

Should means that the rule is a guideline. If a rule expressed in terms of 'should' is broken, a brief comment should be provided describing why the guideline does not apply.

E.2 ETR 141 rules and applicability

RULE 1: Statement of naming conventions
--

Naming conventions should be explicitly stated. Naming conventions should not exist only for a single ATS, and the reader of an ATS should not be forced to "derive" the rules implicitly. The naming conventions should be part of the ATS conventions contained in the ATS specification document.
--

Names used in the present annex are comprised of a prefix part and a name body part. Conventions for deriving prefixes and name bodies are described after Rule 3 in the present annex.

RULE 2: Coverage of naming conventions

Naming conventions stated should, as a minimum, cover the following TTCN objects:

- test suite parameters/constants/variables;
- test case variables;
- formal parameters;
- timers;
- PDU/ASP/structured types;
- PDU/ASP/structured types constraints;
- test suite operations;
- aliases;
- test case/test step identifiers.

RULE 3: General properties of naming conventions

a) Protocol standard aligned

When there is a relationship between objects defined in the ATS and objects defined in the protocol standard, e.g. PDU types, the same names should be used in the ATS if this does not conflict with the character set for TTCN identifiers or with other rules. In case of a conflict, similar names should be used.

b) Distinguishing

The naming conventions should be defined in such a way, that objects of different types appearing in the same context, e.g. as constraint values, can be easily distinguished.

c) Structured

When objects of a given type allow a grouping or structuring into different classes, the names of these objects should reflect the structuring, i.e. the names should be composed of 2 or more parts, indicating the particular structure elements.

d) Self-explaining

The names should be such that the reader can understand the meaning (type/value/contents) of an object in a given context. When suffixes composed of digits are used, it is normally useful to have some rule expressed explaining the meaning of the digits.

e) Consistent

The rules stated should be used consistently throughout the document, there should be no exceptions.

f) Appropriate name length

Following the above rules extensively may occasionally lead to very long names, especially when structuring is used. The names should still be easily readable. When TTCN graphical form (TTCN.GR) is used, very long names are very inconvenient.

NOTE: Also, test tools may not be able to implement very long identifier names, which is an important aspect in this context.

E.2.1 Multiple words are separated by upper case letters at the start of each word

Many names consist of more words, and it shall be easy to distinguish the different words building up the same name. For all TTCN Object classes this is done using the case of the letters.

This rule is mandatory for all names appearing in the body of a dynamic behaviour table, and is recommended for all other TTCN object classes.

Generally every word a name consists of shall start with an upper case letter and the rest of this word shall be in lower case letters.

E.g. "channel" + "description" -> "ChannelDescription"

This rule also applies if a word starts after another upper case letter.

E.g. "px" + "Cell" + "A" + "Cell" + "Id" -> px_CellACellId

This rule also applies if the name has a prefix, which is always lower case.

E.g. A test case variable "sequence" + "number" -> tcv_SequenceNumber

This rule does not apply if the word is a unit, in which case the word retains its original case.

E.g. Power level 1.5 dBm ->PowerLv11_5dBm

This rule does not apply if the word in the name is an acronym, in which case the word retains its normal case.

- If an acronym is followed by another word, an underscore shall be used to separate the acronym from the following word.

E.g.: "this" + "Is" + "SIM" + "Message" + "With" + "CC" + "And" + "RR" + "Things" + "In" + "It" -> "thisIsSIM_MessageWithCC_AndRR_ThingsInIt"

- An exception to acronyms retaining their case is if the name is a field / element / parameter in a structured type / PDU / ASP, in which case it must start with a lower case letter.

E.g. "SCH" + "info" + "element" -> "sCH_InfoElement"

- A further exception to acronyms retaining their case is if the name is an ASN.1 constraint, in which case, in which case the first letter is upper case, and the remaining letters are lower case.

For all objects used in the body of dynamic behaviour tables, use of underscores is discouraged, except for the following situations:

- As a replacement for a '.'. E.g. Test case that maps to prose clause 7.2.3.1 -> tc_7_2_3_1
- To separate prefixes from names.
- To separate acronyms from the following word.
- To replace hyphens when types are re-used / imported from core specifications. This applies to types imported from ASN.1 definitions, and to names derived from table definitions in core specifications.
- To separate an ASP name from the embedded PDU name when the metatype PDU is not used. E.g RRC_DataInd_ConnAck for an RRC data indication ASP with an embedded CONNECT ACKNOWLEDGE PDU.

E.2.2 Identifiers shall be protocol standard aligned

To support rule 3(a), the mapping guidelines in table E1 shall be used. This mapping table also supports rule 6.

Table E1: Mapping guidelines between protocol standards and identifiers

Type	Naming rule
Objects of Structured Type	Shall be derived from the name of the Information Element in the standard, if it corresponds to this (use standard acronyms where appropriate). E.g.: "Window Size super-field" -> "WindowSizeSUF"
Fields in a Structured Type	Shall be derived from the name of the same field in the corresponding Information Element in the standard. (Acronyms for the entire field name shall not be used) E.g.: "Header Extension Type" -> "headerExtensionType" (not "HE")
Objects of ASP type	Shall be derived from the name of the corresponding Service Primitive in the Standard, using any relevant abbreviations from the present annex. The full name as it appears in the core specification shall be included in parentheses after the name. E.g.: "CRLC-SUSPEND-Conf" -> "CRLC_SuspendCnf (CRLC-SUSPEND-Conf)" If the metatype PDU is not used, the ASP name shall reflect both the ASP, and the embedded PDU name, using an underscore to separate the ASP part from the PDU part. E.g. DataReq_StartDTMF_Ack for an RRC-DATA-Req with an embedded START DTMF ACKNOWLEDGE PDU
Objects of PDU type	Shall have exactly the same name as the Message it corresponds to in the standard. If this Message is named by more words, they shall be joined, leaving the blanks out E.g.: "AMD PDU" -> "AMDPDU"

E.2.3 Identifiers shall be distinguishing (use of prefixes)

To support rules 2, 3(b), 4, and 5, the prefixes shown in table E2 shall be used for TTCN objects. Prefixes are separated from the name by an underscore to improve readability by clearly separating the prefix from the name. This convention will also support searching operations. For example, a search for all uses of PIXIT parameters in the test suite is possible by searching for 'px_'.

The optional *<protocol>* part shall be included in the name when the object is closely related to the protocol (e.g. PICS, some PIXIT parameters), it is necessary to be unambiguous or improves comprehension significantly (e.g. no need to think about protocol stacks on all used interfaces during reading). The optional *<protocol>* part shall be used for types defined in common modules.

Table E2: Prefixes used for TTCN objects

TTCN object	Case of first character	Prefix	Comment
Test Suite	Upper	-	
TTCN Module	Upper	-	
Simple Type	Upper	[<protocol>_]	Note 8
Structured Type	Upper	[<protocol>_]	Note 8
Element in Structured Type	Lower	-	
ASN.1 Type	Upper	[<protocol>_]	Note 8
Element in ASN.1 Type	Lower	-	
Test Suite Operation	Upper	o_ [<protocol>_]	Note 1, 8
TSO Procedural Definition	Upper	o_ [<protocol>_]	Note 1, 8
Formal Parameter to TSO or TSOP	Upper	p_	
Test Suite Parameter (PICS)	Upper	pc_ [<protocol>_]	Note 8
Test Suite Parameter (PIXIT)	Upper	px_ [<protocol>_]	Note 8
Test Case Selection Expression	Upper	[<protocol>_]	Note 8
Test Suite Constant	Upper	tsc_ [<protocol>_]	Note 8
Test Suite Variable	Upper	tsv_ [<protocol>_]	Note 8
Test Case Variable	Upper	tcv_ [<protocol>_]	Note 8
PCO Type	Upper	-	
PCO	Upper	-	Note 2
CP	Upper	cp_	Note 2
Timer	Upper	t_ [<protocol>_]	Note 8
Test Component	Upper	mtc_ [<protocol>_] or ptc_ [<protocol>_]	Note 3, 8
Test Component Configuration	Upper	-	
ASP Type	Upper	[<protocol>_]	Note 4, 8
Parameters within ASP Type	Lower	-	Note 4
PDU Type	Upper	[<protocol>_]	Note 4, 8
Fields within PDU Type	Lower	-	Note 4
Encoding Definition	Upper	enc_	
Encoding Variation	Upper	var_	
Invalid Field Encoding Variation	Upper	inv_	
CM Type	Upper	cm_	
Field within CM Type	Lower	-	
Alias	Upper	a_	
ASP constraint	Upper	ca[b d][s r w]_ [<protocol>_]	Note 5, 8
Constraint (other types)	Upper	c[b d][s r w]_ [<protocol>_]	Note 5, 8
Formal Parameter for a Constraint	Upper	p_	
Test Case Group	Upper	<protocol>/	Note 8
Test Step Group	Upper		
Test Case	Upper	tc_	Note 6
Test Step	Upper	(ts_ pr_ po_)<CN domain>_<protocol>_	Note 7, 8, 9
Local tree	Upper	lt_	
Defaults	Upper	<protocol>_	Note 8

NOTE 1: Coding rules are not specified for test suite operation procedural definitions at this stage. These rules will be defined when the need arises

NOTE 2: A prefix is not used for PCO declarations, but is used for CP declarations. This is because PCOs and CPs will only be used in send and receive statements, and PCOs will be used more frequently than CPs. Since a PCO name or a CP name will be used on most behaviour lines, PCO names should be as short as possible – E.g. 2 to 3 characters.

NOTE 3: The prefix is mtc if the component role is MTC, or ptc if the component role is PTC. If multiple PTCs are used, the rest of the identifier will clarify which PTC is being referred to. E.g. ptc_Cell1, ptc_Cell2.

NOTE 4: This applies for both tabular and ASN.1 definitions.

NOTE 5: Constraint prefixes are built up from the following regular expression. $c[a][b|d][s|r|w]$.

- 'c' shall always be present to indicate that the object is a constraint.
- 'a' shall be present for ASP constraints to distinguish them from PDU constraints.
- 'b' shall be present if the constraint is ever used as a base constraint. (i.e. included in the derivation path of any other constraint).
- 'd' shall be present if the constraint is derived from another constraint.(i.e. has an entry in it's derivation path field)
- 'b' and 'd' cannot both be used in the same constraint, thereby limiting the derivation path to 1.
- For the purpose of the present note, the following definitions are required (Ref TR 101 666 clause 12.6.2)
 - The term 'field' is used to represent a structured type element, an ASP parameter, or a PDU field.
 - A 'bound field' is a field that either contains a SpecificValue, or is Omitted (-).
 - An 'unbound field' is a field that contains any of the following matching mechanisms: Complement, AnyValue (?), AnyOrOmit (*), ValueList, Range, SuperSet, SubSet, AnyOne (?), AnyOrNone (*), Permutation, Length, or IfPresent.
- 's' may optionally be present if the constraint is only used in send statements. 's' shall not be present if the constraint contains any unbound fields, or any fields chained to a constraint whose prefix includes 'w' or 'r'.
- 'r' may optionally be present if the constraint is only used in receive statements.
- 'w' may optionally be present to indicate that the constraint contains fields that are unbound. Before these constraints are used in SEND events, all unbound fields must either be bound by using a derived constraint, or explicitly assigned a value in the SEND event behaviour line.
- Either 'w' or 'r' shall be used if any fields in the constraint are unbound or are chained to a constraint whose prefix includes 'w' or 'r'.

NOTE 6: Test case names will correspond to the clause in the prose that specifies the test purpose. E.g. tc_7_2_23_2. An additional digit may be specified if more than one test case is used to achieve the test purpose. If an additional digit is required, this probably means that the test prose are not well defined.

NOTE 7: Test steps may optionally use the prefixes pr_ or po_ to indicate that the test step is a preamble or postamble respectively.

NOTE 8: Protocol abbreviations are provided in table E3. Protocol abbreviations may optionally be used to clarify the scope of TTCN objects, or to resolve conflicts when the same name is required by multiple protocols within the ATS.

If two different types exist in the ATS that represent the same information (e.g. IMSI) conversion operations shall be used to ensure consistency between the types. Also, conversion operations shall be used to avoid asking the same PIXIT question twice. For example, if a type is defined as an OCTETSTRING[4] for a NAS protocol, and the same type is represented as a BITSTRING[32] for RRC, a single PIXIT question shall be asked, and conversion operations shall be used to ensure that the same value is used for both types.

Table E3: Protocol abbreviations for prefixes

Protocol / prefix
BMC
CC
CS
GMM
MAC
MM
PDCP
RLC
RRC
SMS
SS
TC

NOTE 9: The prefixes CS and PS may optionally be used to indicate that a test step is specific to circuit switched, or packet switched signalling respectively. For test steps specific to the Upper Tester, the prefixes AT or MMI or UT shall be used to indicate that, respectively, AT or MMI or both types of commands are used.

E.2.4 Identifiers should not be too long (use standard abbreviations)

To assist in keeping TTCN identifiers shorter, table E4 provides a non-exhaustive set of standard abbreviations that shall be used when naming objects that are used in the body of dynamic behaviour tables. Consistent use of abbreviations will improve test suite readability, and assist maintenance.

Table E4: Standard abbreviations

Abbreviations	Meaning
Acs	access
Acp	accept
Ack	acknowledge
act	activation
addr	address
(re)alloc	(re)allocated, (re)allocation
arg	argument
ass	assignment
auth	authentication
ava	avail, available
bCap	bearer capability
cau	cause
clg	calling
ch	channel
chk	check
ciph	cipher, ciphering
clد	called
clsmk	classmark
cmd	command
cmpl	complete
cnf	confirm
cfg	configuration
conn	connect
ctrl	control
def	default
descr	description
disc	disconnect
enq	enquiry
err	error
(re)est	(re)establish
ext	extended
fail	failure
ho	handover
id	identity / identification
ie	information element
iel	information element length
ind	indication
info	information
init	initialize
lvl	level
loc	location
locUpd	location update
max	maximum
mgmt	management
min	minimum
misc	miscellaneous
mod	modification
ms	mobile station
msg	message

Abbreviations	Meaning
mt	mobile terminal
neigh	neighbour
ntw	network
num	number
orig	origin/-al
pag	page/-ing
params	parameters
perm	permission
phy	physical
qual	quality
rand	random
ref	reference
reg	register
rej	reject
rel	release
req	request
rsp	response
rx	receiver
sel	selection
seq	sequence
serv	service
st	state
sysInfo	system information
sync	synchronization
sys	system
tx	transmitter

RULE 4: Specific naming rules for test suite parameters/constants/variables test case variables and formal parameters

- a) The name should reflect the purpose/objective the object is used for.
- b) If the type is not a predefined one, it is useful that the name reflects the type, too.
- c) It could be useful, that the individual naming conventions are not the same for all object classes this rule applies to. e.g. use upper case letters for test suite parameters/constants, and use one of the other possibilities presented in ETR 141 example 1 for other object classes.

See also ETR 141 clauses 5.1-5.4 for further discussion on naming test suite parameters.

RULE 5: Specific naming rule for timers

If the timer is not defined in the protocol to be tested, the name should reflect the objective of the timer used for testing.
NOTE: There is no need to indicate the object type "timer" in the name, since timers only occur together with timer operations

RULE 6: Specific naming rule for PDU/ASP/structured types

As far as applicable, derivation rules or mapping tables should be used to relate the names of the types to the corresponding objects in the protocol or service definition.
NOTE: There may be types, e.g. erroneous PDU types, that do not relate to an object in the protocol or service definition.

Whenever names of types are derived from ASN.1 type definitions provided in the core specifications, the names shall remain the same as the ASN.1 specifications, and references shall be provided in the comment fields.

RULE 7: Specific naming rule for PDU/ASP/structured types constraints

Rules should be stated to derive the names from the names of the corresponding type definitions. It is often possible to use the type name plus an appropriate suffix reflecting the specific constraint value. In case of lengthy names, useful abbreviations or a defined numbering scheme can be chosen.

Constraint names begin with the appropriate prefix, followed by the first letter of each word in the type, followed by words describing the peculiarity of the constraint. E.g. Type = RadioBearerSetupPDU, constraint name could be cb_RBSP_GenericUM_DTCH.

RULE 8: Specific naming rule for test suite operations

The name should reflect the operation being performed.
i.e. the name should indicate an activity, not a status. This can be achieved e.g. by using appropriate prefixes like "check", "verify", etc.

RULE 9: Specific naming rule for aliases

The name should reflect that aspect of its expansion, that is important in the situation where the alias is used. Derivation rules should be provided to derive the alias name from its macro expansion or from the name of an embedded ASP / PDU.

See also ETR 141 clauses 6.3.6 and 9 for further guidelines on naming aliases.

RULE 10: Specific naming rule for test steps

The name should reflect the objective of the test step.

RULE 11: Selecting the ASN.1 format for type definitions

- a) If the protocol standard uses ASN.1 to specify the PDUs, the ATS specifier should also use ASN.1.
- b) If the protocol standard does not use ASN.1, check carefully whether features of ASN.1 that the tabular format of type definition does not present are necessary in the ATS, or could ease the design and understanding of the definitions as a whole. Check especially whether fields or parameters have to be specified, the order of appearance of which, in a received ASP/PDU, cannot be predicted. If any of these conditions apply, use ASN.1 for type and ASP/PDU type declarations.
- c) Use the option of "ASN.1 ASP/PDU type Definitions by Reference" whenever applicable.
- d) Example 14 shows a compatibility problem that could occur, when ASN.1 type declarations as well as tabular type declarations are used in an ATS. Use the ATS Conventions to describe how this compatibility problem is handled in the ATS, i.e. whether in expressions and assignments entities defined in ASN.1 are only related to entities defined in ASN.1 or not.

Names of ASN.1 objects shall be kept the same as the core specifications in this case, even where the names are at odds with the naming conventions adopted for other TTCN objects.

RULE 12: Further guidelines on type definitions

- a) Use simple type or ASN.1 type definitions whenever an object of a base type with given characteristics (length, range, etc.) will be referenced more often than once.
- b) Use the optional length indication in the field type or parameter type column of structured type and ASP/PDU type definitions whenever the base standard/profile restricts the length.
NOTE 1: This can often be achieved by references to simple types.
- c) Map the applicable ASPs/PDUs from the service/protocol standard to corresponding ASP/PDU type definitions in the ATS.
NOTE 2: It may happen that not all ASPs/PDUs of a service/protocol standard are applicable to a particular ATS for the related protocol. It may also happen that additional ASP/PDU type declarations are necessary, e.g. to create syntactical errors.
- d) Map the structure of ASPs/PDUs in the service/protocol standard to a corresponding structure in the ATS.
NOTE 3: This mapping is not always one-to-one, e.g. because a field in the PDU definition of the protocol standard is always absent under the specific conditions of an ATS. But it should normally not happen, that a structured element in the protocol standard is expanded using the "<-" macro expansion, so that the individual fields are still referenced, but the structure is lost in the ATS.

RULE 13: Specification of test suite operations

- a) Use a test suite operation only if it cannot be substituted by other TTCN constructs.
- b) Write down the rationale/objective of the test suite operation.
Reference standards if applicable.
- c) Classify and simplify algorithm.
Split test suite operation if too complex.
- d) Choose an appropriate specification language depending on the rationale/objective:
 - predicates for Boolean tests;
 - abstract data types for manipulation of ASN.1 objects;
 - programming languages for simple calculation.
- e) Check/proof the test suite operation:
 - is the notation used known/explained;
 - are all alternative paths fully specified;
 - is the test suite operation returning a value in all circumstances;
 - are error situations covered (empty input variables, etc.).
- f) State some evident examples.

E.2.5 Test suite operations must not use global data

All information required by test suite operations must be passed as formal parameters. This includes test suite variables, test case variables, test suite parameters, and constraints.

RULE 14: General aspects of specifying constraints

- a) Develop a design concept for the complete constraints part, particularly with respect to the "conflicting" features as indicated in items i) to iv) and including naming conventions (see ETR 141 Clause 6).
- b) Make extensive use of the different optional "Comment" fields in the constraint declaration tables to highlight the peculiarity of each constraint.

RULE 15: Relation between base constraints and modified constraints

- a) Define different base constraints for the send- and receive direction of a PDU (when applicable).
- b) Use modified constraints preferably when only a small number of fields or parameter values are altered with respect to a given base.
NOTE 1: For SEND events the creation of a further modified constraint can sometimes be avoided, if an assignment is made in the SEND statement line, thus overwriting a particular constraint value.
- c) Design the relation between base constraints and modified constraints always in connection with parameterization of constraints (see the two subsequent subclauses).
NOTE 2: Additional parameters in a constraint, introduced to avoid the declaration of further base/modified constraints can reduce the amount of constraints needed in an ATS, but then the constraint reference is getting more and more unreadable.
- d) When modified constraints are used, keep the length of the derivation path small. The length of the derivation path (resulting from the number of dots in it) is a kind of nesting level, and it is known from experience that a length greater than 2 is normally difficult to overview and maintain.

Modified constraints should not have a derivation path longer than 1. A modified constraint should not alter more than 5 values with respect to a given base constraint. If a constraint is used as a base constraint, it must have the prefix 'cb', to warn test suite maintainers / developers that any changes to this constraint may cause side effects.

Note that if an existing constraint without the 'cb' prefix is to be used as a base constraint, either a new, identical constraint with an 'cb' prefix must be created, or the existing constraint must be renamed to include the 'cb' prefix in all places it is referenced in the test suite.

[Outstanding issue: Stating that all base constraints must have the 'cb' prefix may result in ALL constraints having this prefix, in case they are used as base constraints at a later stage during development. If this occurs, the 'b' becomes redundant, and should be removed from the coding conventions.]

RULE 16: Static and dynamic chaining

- a) Make a careful evaluation of which embedded PDUs are needed in ASPs/PDUs, in which (profile) environment the ATS may operate and which kind of parameterization for other parameters/fields is needed, to find an appropriate balance between the use of static and/or dynamic chaining in a particular ATS.
- b) When the ATS is used in different profile environments and the types and values of embedded PDUs cannot be predicted, dynamic chaining is normally the better choice.
- c) When static chaining is used, choose the name of the ASP/PDU constraint such that it reflects the peculiar value of the embedded PDU (see also the clause on naming conventions in ETR 141).

RULE 17: Parameterization of constraints

- a) Make a careful overall evaluation of which field/parameter values are needed in ASPs and PDUs to find an appropriate balance between the aim of a comparably small number of constraint declarations and readable and understandable constraint references.
- b) Keep the number of formal parameters small.
Keep in mind, that the number of formal parameters in structured/ASN.1 types Constraints will add up to the total number of ASP/PDU constraints.
A clear border for the number of formal parameters cannot be stated, but it is known from experience that a number bigger than 5 normally cannot be handled very well.

Constraints should not be passed more than five parameters. Instead, more constraints should be defined. Related parameters can be grouped in new structured types to reduce the number of parameters that must be passed to constraints.

[NOTE: The value five has been selected based on the recommendation in ETR 141 rule 17. If more parameters are required, we can update this rule, or use more than 5 parameters, and provide documentation indicating why more parameters are required.]

A constraint should not be passed parameters to that are not processed in that constraint. If for example a parameter is to be passed from a PDU constraint to a structured type constraint then the PDU constraint should be made specific and not have that parameter passed. The reason for this is that no editors as yet can trace through this mechanism and it becomes very difficult in a complex suite to see exactly what is being passed.

For example:

```
PduA ::= SEQUENCE {
    infoElement1 InformationElementType1,
    infoElement2 INTEGER
}

InformationElementType1 ::= SEQUENCE {
    field1 INTEGER,
    field2 INTEGER
}

cb_PATypical( p_Field1: INTEGER; p_Field2: INTEGER ) ::= {
    infoElement1 c_IET1Typical( p_Field1 ),
    infoElement2 pField2
}

c_IET1Typical( p_Field1: INTEGER ) ::= {
    field1 p_Field1,
    field2 5
}
```

In the example constraint cb_PATypical, passing p_Field1 through to a nested constraint is not allowed, but the use of p_Field2 is acceptable.

RULE 18: Constraint values

- a) Use comments to highlight the peculiarity of the value, especially when the value is a literal, whose meaning is not apparent.
- b) Use test suite constants instead of literals, when appropriate.
Normally not all literals can be defined as Test Suite Constants, but a rule by thumb is: if a literal value of a given type occurs more than once (as a constraint value or more generally in an expression), then it is useful to define it as a Test Suite Constant, letting the name reflect the value.
- c) Use the length attribute when possible and when the length is not implicit in the value itself or given by the type definition (e.g. for strings containing "**").

RULE 19: Verdict assignment in relation to the test body

Make sure that verdict assignment within a default tree is in relation to the test body. If an unsuccessful event arising in the test body is handled by the default tree, then assign a preliminary result "(FAIL)" within the corresponding behaviour line of the default tree. If the position of the unsuccessful event is not in the test body, assign a preliminary result "(INCONCLUSIVE)". If the behaviour line handling the unsuccessful event is a leaf of the default tree, assign a final verdict instead.

RULE 20: Test body entry marker

The entry of the test body should be marked.

RULE 21: State variable

For realizing test purposes dependent on protocol states, use a variable to reflect the current state of the IUT.

RULE 22: State checking event sequences

Combine event sequences used for checking a state of the IUT within test steps.

RULE 23: Easy adaptation of test steps to test cases

For easy adaptation of a test step to test case needs, parameterize the constraints used within a test step.

Test steps may be parameterised, but with no more than five parameters. See also ETR 141 clause 12.2 and rule 28. Related parameters can be grouped in new structured types to reduce the number of parameters that must be passed to constraints.

[NOTE: Again, the value five has been selected based on the recommendation in ETR 141 rule 17. If more parameters are required, we can update this rule, or use more than 5 parameters, and provide documentation indicating why more parameters are required.]

RULE 24: Minimizing complexity of test steps

Minimize the complexity of test steps either by restricting the objective of a test step to atomic confirmed service primitives or by separating event sequences, which build different "logical" units into different test steps.

RULE 25: Nesting level of test steps

Keep the nesting level of test steps to a minimum.

RULE 26: Recursive tree attachment

Avoid recursive tree attachment. Where possible, use loops instead of recursive tree attachments.

RULE 27: Verdict assignment within test steps

If verdicts are assigned within a test step, guarantee at least the partial (i.e. not general) re-use of the test step.

RULE 28: Parameterized test steps

Use parameterized test steps to ensure re-use of test steps within test cases for different needs.

RULE 29: Combining statements in a sequence of alternatives

If there is no Boolean expression included in an alternative sequence, a statement of type UCS should never be followed by a statement of type UCS or CS within a sequence of alternatives.

RULE 30: Using relational expressions as alternatives

- a) A relational expression should never restrict the value range of a preceding relational expression in the same alternative sequence using the same variable.
- b) The value range of a relational expression should be different from the whole value range of all preceding relational expressions in the same alternative sequence using the same variable.

RULE 31: Loop termination

Do not use conditions for terminating loops, which depend only on the behaviour of the IUT.

RULE 32: Avoiding deadlocks

- a) Make sure that each alternative sequence of receive events contains an OTHERWISE statement (without any qualifier) for each PCO.
- b) Make sure that each alternative sequence of receive events contains at least one TIMEOUT event (implying that a corresponding timer was started).

A set of alternatives using qualifiers shall always include an alternative containing the qualifier [TRUE], to provide a default behaviour if none of the qualifiers match.

For example:

```
[ tcv_Value = 1 ]
  AM ! ASP_ForValue1
  ...
[ tcv_Value = 2 ]
  AM ! ASP_ForValue2
  ...
[ TRUE ]
  AM ! ASP_ForOtherValues
  ...
```

RULE 33: Straightforward specification of test cases

- a) Use only event sequences leading to the test body within a preamble.
- b) Handle all event sequences not leading to the test body within the default tree of the test case/step.
- c) If the very same event sequence can be used to transfer the IUT from each possible state to the idle state, then realize this event sequence as a postamble.

RULE 34: Test component configuration declaration

Avoid recursive test component configuration declarations.

RULE 35: Default trees with RETURN statement

Special care should be taken by using a RETURN statement within a default tree in order to avoid an endless loop resulting from the expansion of the default tree.

E.3 3GPP ATS implementation guidelines

This clause provides a set of guidelines that must be followed during ATS development. In general, these guidelines are intended to prevent developers from making common errors, or discuss considerations that must be taken into account before using specific features of the TTCN language.

E.3.1 Test case groups shall reflect the TSS&TP document

Test groups shall be used to organise the test cases in the same way as the test purposes are structured in the prose specification.

The general structure of the test groups should be in the following format.

`<protocol>/<group>/<subgroup>`

E.g. RLC/UM/Segmentation/LengthIndicator7bit/

E.3.2 Test case names correspond to the clause number in the prose

Test case names are derived directly from the clause number in the prose specification. Decimal points between digits in the clause number are replaced with underscores. E.g. the test case name for the test purpose specified in clause 7.2.3.2 of 34.123-1 is tc_7_2_3_2. If more than one test case is required to achieve a test purpose, an additional digit may be added. See also ETR 141 clause 6.3.7

E.3.3 Use standard template for test case and test step header

Table E5 illustrates how the Test Case dynamic behaviour header fields should be used.

Table E5 – Template for TTCN test case table header

Field		Contents				
Test Case Name:		tc_NUMBER_OF_TESTCASE The number of the test case, which is used in the name of the test case, is the number it has in the prose specification. e.g.: "tc_26_13_1_3_1"				
Group:		Is automatically filled and cannot be changed				
Purpose:		This is taken directly from the prose specifications.				
Configuration:		As required if concurrent TTCN is being used.				
Default		The appropriate default				
Comments:		<u>First line contains:</u> Specification: The names and sub clauses of relevant core specifications. <u>Next line contains:</u> Status: OK / NOT OK (+explanation if not ok) / Version number / Validated / Reviewed etc... E.g.: Status: OK <u>Rest of lines give comments as:</u> What has to be done before running this test? E.g.: 1. Generic setup procedure must be completed before running this test. Any special information about what might be needed for the testing system, like specific requirements for the testing system, specific hacks, certain settings etc. This field should be short (if long description is needed it must be put into Detailed Comments)				
Selection Ref:		The appropriate test case selection expression.				
Description:		Optional. Max 4 lines. If available, this should be the title of the prose clause. Note 10				
Nr	Label	Behaviour	Description	Constraints Ref	Verdict	Comments
1			Note 12	Note 12		Note 11
Detailed Comments		Contains detailed information about test steps + additional information Note 11				

NOTE 10: The description field in the test case / step header is used to generate the test suite overview, and should only include a brief overview of the test case / step with a maximum of 4 lines. For a more detailed description of the test case / step algorithm / parameters etc, the comments or detailed comments fields should be used.

NOTE 11: The comments field for each behaviour line should usually consist of a number that is a reference to a specific numbered comment in the detailed comments field. If this extra level of indirection reduces readability, brief comments can be used in the comments field for each behaviour line.

NOTE 12: If entries in the behaviour description or constraints reference column contain lists with more than one element, carriage returns should be used between list elements to prevent the line from becoming too long.

Table E6 illustrates how the Test Case dynamic behaviour header fields should be used.

Table E6: Template for TTCN test case table header

Test Step Name	ts_TestStepName(p_Param1: Param1Type; p_Param2: Param2Type)				
Group	Is automatically filled and cannot be changed				
Objective	The objective of the test case. Provides a brief summary of the functionality of the test step.				
Default	The appropriate default				
Comments	<p>A detailed description of the test step, including the relevant items from the following categories:</p> <p>Algorithm A detailed description of the algorithm / principles used within the test step</p> <p>Parameters: A description of each of the parameters passed to the test step, including the purpose of the parameter, valid values, restrictions etc.</p> <p>Preconditions The required state of the UE and / or SS before using this test step, including test steps that should be executed before using the present test step, and a description of all test case variables that must contain appropriate values before using this test step.</p> <p>Postconditions The expected state of the UE and / or SS after using this test step, including a description of all test case variables that will be modified by this test step.</p> <p>NOTE: It is too difficult to maintain the list of variables required / affected by nested test steps, so it is the users responsibility to check which variables are required / affected by nested test steps.</p>				
Description	Optional. Max 4 lines. Note 10				
Nr	Label	Behaviour Description	Constraints Ref	Verdict	Comments
1		Note 12	Note 12		Note 11
Detailed Comments	Contains detailed information about test steps + additional information Note 11				

E.3.4 Do not use identical tags in nested CHOICE constructions

A nested CHOICE requires tags in the different alternative type lists to differ (see ISO 8824, sub clause 24.4, EXAMPLE 3, INCORRECT). 'The tag shall be considered to be variable, ... becomes equal to the tag of the "Type" ... from which the value was taken.'

EXAMPLE: components are defined in a nested CHOICE construction, but no distinguishing tags are used to make the difference between component types, i.e. tags for different types turn out to be identical.

```

Component ::= CHOICE {
  gSMLocationRegistration_Components  GSMLocationRegistration_Components,
  gSMLocationCancellation_Components  GSMLoactionCancellation_Components,
  ...
}

GSMLocationRegistration_Components ::= CHOICE {
  gSMLocationRegistration_InvokeCpt    [1] IMPLICIT GSMLocationRegistration_InvokeCpt,
  gSMLocationRegistration_RRCpt        [2] IMPLICIT GSMLocationRegistration_RRCpt,
  gSMLocationRegistration_RECpt        [3] IMPLICIT GSMLocationRegistration_RECpt,
  gSMLocationRegistration_RejectCpt    [4] IMPLICIT RejectComponent
}

GSMLocationCancellation_Components ::= CHOICE {
  gSMLocationCancellation_InvokeCpt    [1] IMPLICIT GSMLocationCancellation_InvokeCpt,

```

```
gSMLocationCancellation_RejectCpt [4] IMPLICIT RejectComponent
}
```

gSMLocationRegistrationInvokeCpt and gSMLocationCancellation_InviteCpt have the same tag and can therefore not distinguished anymore. Note that ITEX 3.5 does not report this error.

E.3.5 Incorrect usage of enumerations

Enumerations may contain distinct integers only (see ISO 8824, sub clause 15.1)

EXAMPLE: TypeOfNumber containing a NamedValueList in which there are non-distinct values.

```
TypeOfNumber ::=      ENUMERATED {
.....
internationalnumber (1),
level2RegionalNumber (1),
nationalNumber      (2),
level1RegionalNumber (2),
.....
}
```

E.3.6 Structured type as OCTETSTRING should not be used

"It is required to declare all fields of the PDUs that are defined in the relevant protocol standard, ..." TR 101 101 TTCN specification clause 11.15.1

EXAMPLE: The ISDN Bearer Capability Information Element (BCAP) contents is defined as OCTETSTRING.

EXAMPLE: Usage of data type BITSTRING [7..15] as data type of the Call Reference (= 7 bits or =15 bits, but not 8 bits for example) does not correspond to the specification !!).

E.3.7 Wildcards in PDU constraints for structured types should not be used

Values ? and * are incorrect in PDU constraints where they are used to indicate values of structured types, because they would allow any combinations of values – even incorrect ones - which is not admissible according to the specifications. It is to be kept in mind that in tabular form each field is optional! It would be better to create and use an "any"-constraint which would deal with all the fields in detail (mandatory, IF PRESENT, etc.). See TBR 33, 34 as example.

[TODO: Use of wildcards vs. 'any' constraints requires some further discussion]

E.3.8 TSOs should be passed as many parameters as meaningful to facilitate their implementation

Parameters should be passed to TSOs to facilitate the TSO realization. If a TSO is used in various contexts, this should be reflected in the parameters passed to the TSO. Specifically, TSOs operating on well-defined (parameterized) constraints should take these constraints (including relevant parameters) as parameters if required.

BAD EXAMPLE: In this example, the TSO may be used in many contexts, but no information is passed to the TSO, which makes TSO realization difficult.

		L?SETUPr (... tcv_invokeId := TSO_GET_INVOKEID (), ...)	Sr (SU_GR3(GSM_IncomingCallMMInfo_In voke(...)))		
--	--	--	---	--	--

GOOD EXAMPLE: In this case, the TSO is provided with information about the data object from which the invoke Id is to be extracted, and the type of component from which the invoke Id is to be extracted is identified by passing the component constraint.

		L?SETUPr (... tcv_invokeId := TSO_GET_INVOKEID (DL_DataInd_Setup.msg, GSM_IncomingCallMMInfo_Invoke(...)), ...)	Sr (SU_GR3(GSM_IncomingCallMMInfo_In voke(...)))		
--	--	--	---	--	--

To calculate the invocation identification and store the result in variable tcv_invokeId the TSO has to be provided with information about the data object from which the invoke Id is to be extracted. PDU constraint SU_GR3 may contain several components. In the specific situation only one of these components is relevant.

Depending on the nature of the TSO, passing the received value, or a subcomponent of the received value may be more appropriate than passing the constraint.

E.3.9 Specification of Encoding rules and variation should be indicated

TTCN does not mandate encoding rules, although TTCN foresees that applicable encoding rules and encoding variations can be indicated for the data structures used in a test suite.

There are standards defining encoding rules, e.g. the ITU-T X.680 series. However, the type of encoding called "Direct Encoding" - a bit-by-bit-mapping from the data definitions onto the data stream to be transmitted - is not defined anywhere. It therefore needs a "home".

TTCN should therefore define which encoding rules may legally be used by TTCN test suite specifiers. All the encoding rules defined in the X.680 series should be contained in this repertoire. Additionally an encoding rule called Direct Encoding is needed in particular for tabular TTCN.

X.680 allows to encode data objects using different length forms (short, long, indefinite). These could be used alternatively as encoding variations. Another encoding variation could be the "minimum encoding", accepting any of the length forms in reception, and using the shortest of the available forms in sending. The variation actually used has to be described somewhere (in the ATS).

EXAMPLE: In EN 301 144-4 BER is used as encoding variation, but is in fact an encoding rule. Furthermore no default encoding is specified which would apply to those data structures for which no encoding rule or encoding variation is explicitly specified.

E.3.10 Use of global data should be limited

The Phase 2 ATS became extremely complex due to the global definition of data. Data should be defined locally where possible if the language allows, alternatively the names of global constraints could be given prefixes to indicate their use.

E.3.11 Limit ATS scope to a single layer / sub-layer

Separate ATSs should be produced to test each Layer and perhaps sub Layer. By doing this preambles and common areas particular to one sub Layer can be confined to one test suite and parallel development of test suites can be facilitated.

E.3.12 Place system information in specially designed data structures

System Information data could be stored in specially defined data structures, use of these structures to build PDUs may help to ensure that a consistent set of data is transmitted in all the channels in a cell.

E.3.13 Place channel configuration in specially designed data structures

Likewise the configuration of a 'channel' could be stored in similar structures. This data can then be used to configure the test system and to build Assignment messages to the UE under test. This may help avoid the situation where the TTCN creates one channel and unintentionally commands the mobile to a different, non-existent, channel.

E.3.14 PICS / PIXIT parameters

It is desirable to limit the scope of PICS / PIXIT parameters.

A default value shall be provided in the PIXIT document for all PIXIT parameters.

PICS / PIXIT parameters shall not include structured types. If a structured parameter is required, several parameters shall be used, one for each simple element within the type, and a constraint shall be created to combine the simple parameters into a structured type.

For example, to use the following structured type as a parameter:

Type Name	LocAreald_v		
Encoding Variation			
Comments	Location Area Identification Value 3GPP TS 24.008 cl. 10.5.1.3		
Element Name	Type Definition	Field Encoding	Comments
mcc	HEXSTRING[3]		MCC 3 digits
mnc	HEXSTRING[3]		MNC 3 digits
lac	OCTETSTRING[2]		LAC
Detailed Comments			

The following three PIXIT parameters should be defined: Parameter Name	Type	PICS/PIXIT Ref	Comments
px_LACDef	OCTETSTRING	PIXIT TC	default LAC
px_MCCDef	HEXSTRING	PIXIT TC	default MCC
px_MNCDef	HEXSTRING	PIXIT TC	default MNC

And then the following constraint can be used to combine the simple parameters into a structured parameter:

Constraint Name	cb_LocArealdDef_v		
Structured Type	LocAreald_v		
Derivation Path			
Encoding Variation			
Comments			
Element Name	Element Value	Element Encoding	Comments
mcc	px_MCCDef		
mnc	px_MNCDef		
lac	px_LACDef		
Detailed Comments			

E.3.15 Dynamic vs. static choices

Don't use wildcards for static choice constraints. For example, a type that is similar for FDD and TDD should have 2 type definitions, rather than a single type that uses an ASN.1 choice. Then in the TTCN, the correct type should be selected based on test suite parameters.

E.g.:

```
[ pxUseTddMode ] AM ! TddSpecificAsp
  AM ?
  ...
[ pxUseFddMode ] AM ! FddSpecificAsp
  AM ? ...
  ...
```

E.3.16 Definition of Pre-Amble and Post Ambles

Test cases should, as far as possible, use one of a set of standard pre-amble to place the user equipment in its initial conditions. These pre-amble should align with the generic setup procedures in the conformance specification. All non-standard pre-amble should be identified and added to the pre-ambles library.

With pre-amble readability is very important so they should not use other test steps to send message sequences, and they should be passed as few parameters as possible. This also makes the results log easier to read.

The prose message sequence charts should be analysed, and a catalogue of common ways in which the test cases can terminate (correctly or incorrectly) created. This catalogue should be used to create a set of post-amble. All final verdicts should be assigned in the post-amble.

Wherever possible, a post-ambles should return the test system and the User Equipment under test to a known idle state.

E.3.17 Use test steps to encapsulate AT and MMI commands

When the same AT or MMI command is to be used more than once within a test suite, the command should be placed within a test step, to ensure that the same information is provided consistently. The main intention of this guideline is to ensure that MMI commands provided to the user are consistent, and can be changed easily if required.

For example, a test step similar to the one illustrated in table E7 should be created and attached so that the same information is provided to the user each time the test step is used, and the string to be sent only exists in one place within the test suite.

Table E7: Example test step to encapsulate AT / MMI commandsDefault behaviour

Test Step Name		ts_AT_MMI_Example			
Group					
Objective		Send an MMI command instructing the user to insert the USIM card into the UE.			
Default					
Comments		Encapsulate an AT / MMI command within a test step to ensure that the same information is used consistently, and the information only exists in one place within the test suite.			
Description					
N	Label	Behaviour Description	Constraints Ref	Verdict	Comments
1		Ut ! MMI_CmdReq	ca_MMICmdReq (" Please insert the USIM card into the UE ")		
2		Ut ? MMI_CmdCnf	ca_MMICmdCnf		

Defaults are test steps that are executed when ever a receive event occurs that is not expected. Not expected means that it does not match any of the defined ASP constraints at that point in the test case. The default behaviour used in test case is defined in the test case declaration. They can be defined to stop the test case by calling a standard post-amble or receive the event as OTHERWISE and RETURN back to step where the unexpected event occurred.

A strategy for dealing with unexpected behaviour involving consistent use of defaults should be developed, and applied to test cases wherever possible.

If during a test case or test step it is necessary to change the default behaviour, the ACTIVATE statement may be used.

E.3.18 Use system failure guard timers

A timer should be set at the beginning of each test case to guard against system failure. Behaviour on expiry of this timer should be consistent for all test cases.

E.3.19 Mapping between prose specification and individual test cases

The ATS should map one-to-one between test cases and tests as described in 32.123-1. A method for ensuring that the two specifications track each other needs to be defined.

E.3.20 Verdict assignment

E.3.20.1 General

Final verdicts shall only be used to indicate test case errors, or when unexpected UE behaviour occurs such that it not sensible to continue the test. When a test case reaches a leaf node, the test case ends, and the current preliminary verdict is assigned. At least one preliminary verdict shall be assigned for every test case. If a test case terminates and no final or preliminary verdicts have been assigned, the current value of the predefined variable R will be 'none', and a test case error is recorded instead of a final verdict.

Labels shall be used for every line in which a verdict is posted to improve the traceability of the conformance log produced when the test case is executed. These labels should be kept short, since they appear in the dynamic behaviour tables.

All test suites shall make use of a global boolean variable, defined in the common module, called `tcv_TestBody`. `tcv_TestBody` is updated within each test case to indicate if the test body is currently being executed. `tcv_TestBody` is referenced in defaults and test steps to assign a preliminary inconclusive verdict when unexpected events occur outside of the test body, or a preliminary failure verdict when unexpected events occur within the test body.

The initial value in the declaration of the test case variable `tcv_TestBody` shall be `FALSE`. The variable will be bound to this value when the ATS is initialised, and will be re-bound to this value after termination of each test case, ready for execution of the next test case.

E.3.20.2 Test cases

A line similar to line 3 in table E8 shall be used in all test cases to set `tcv_TestBody` to `TRUE`. This line shall have the label TBS to indicate the Test Body Start point.

A line similar to line 6 in table E8 shall be used in all test cases to set `tcv_TestBody` to `FALSE`. This line shall have the label TBE[N] to indicate the Test Body End point. A number N (with one or more digits) may optionally be appended to the label to distinguish between multiple test body end points. If the number of possible test sequences makes management of the `tcv_TestBody` variable too difficult, the variable can be set to `TRUE` at the beginning of the test. In this case, a comment shall be added to the test case noting that `tcv_TestBody` is not updated, so verdicts assigned within preambles and postambles will be treated as if they are part of the test body.

Within the test body, preliminary verdicts shall be used to indicate the result of the test purpose. Each behaviour line within the test body containing a preliminary verdict shall have a label of the form TBXN, where X is one of P, F, I for pass, fail, and inconclusive respectively, and N is a number (with one or more digits) used to distinguish multiple TBPs, TBFs, or TBIs in the same test case.

If an unexpected event occurs corresponding to a test case error, a final inconclusive verdict shall be assigned, and the behaviour line shall have a label ERRN, where N is a number used to distinguish multiple ERRs, and ERR indicates that a test case error has occurred. An example of this is provided in the test step clause.

Table E8 contains an example test case illustrating these concepts.

Table E8: Example test case illustrating use of verdicts, labels and tcv_TestBody test case variable.

Nr	Label	Behaviour Description	Constraints Ref	Verdict	Comments
1		+ts_Preambles			
2	TBS	(tcv_TestBody := TRUE)			1
3		L ! Stimulus	cs_Stimulus1		
4		+lt_Response			
5	TBE	(tcv_TestBody := FALSE)		(P)	2
6		+ts_Postambles			
		lt_Response			
7	TBP1	L ? Response	cr_ValidResponse1	(P)	3
8	TBP2	L ? Response	cr_ValidResponse2	(P)	3
9	TBF1	L ? Response	cr_InvalidResponse	(F)	4
10	TBI1	L ? Response	cr_OtherResponse	(I)	5
Detailed comments		<ol style="list-style-type: none"> 1. The behaviour line setting tcv_TestBody to TRUE shall have the label TBS 2. The behaviour line setting tcv_TestBody to FALSE shall have the label TBE, and can optionally be used to assign a verdict indicating that the test purpose has passed or failed (i.e. if the final behaviour statement in the test body is a tree attachment) 3. The label TBPn is used to indicate that the test purpose has been achieved via the Nth possible valid UE behaviour 4. The label TBFn is used to indicate that the test purpose has not been achieved, due to the Nth possible failure cause 5. The label TBin is used to indicate that the test result is inconclusive for the Nth possible unexpected / unknown event 			

E.3.20.3 Test steps

To promote re-use, test steps shall only assign preliminary verdicts (I) and (F). (P) verdicts shall be managed at the test case level in general, but may be used sparingly within test steps. ETR 141 clause 12.4 recommends that a preliminary pass verdict should be assigned at the leaf of each passing event sequence of the test step. If a test step includes an alternative for unexpected / invalid behaviour, then either a preliminary inconclusive verdict shall be assigned if tcv_TestBody is FALSE, or a preliminary failure verdict shall be assigned if tcv_TestBody is TRUE.

Each behaviour line within the test step containing a preliminary verdict shall have a label of the form TSXN, where X is one of P, F or I for pass, fail, and inconclusive respectively, and N is a number (with one or more digits) used to distinguish multiple TSPs, TSFs, or TSIs in the same test step.

If an unexpected event occurs corresponding to a test case error, a final inconclusive verdict shall be assigned, and the behaviour line shall have a label ERRN, where N is a number used to distinguish multiple ERRs, and ERR indicates that a test case error has occurred.

Table E9 contains an example test step illustrating these concepts.

Table E9: Example test step illustrating use of verdicts, labels and tcv_TestBody test case variable.

Nr	Label	Behaviour Description	Constraints Ref	Verdict	Comments
1		[p_Mode = tsc_Mode1]			
2		L ! Stimulus	cs_Stimulus1		
3		+It_Response			
4		[p_Mode = tsc_Mode2]			
5		L ! Stimulus	cs_Stimulus2		
6		+It_Response			
7	ERR1	[TRUE]		I	1
		It_Response			
8		L ? Response	cr_ValidResponse1		2
9		L ? Response	cr_InvalidResponse		
10	TSI1	[tcv_TestBody = FALSE]		(I)	3
11	TSF1	[tcv_TestBody = TRUE]		(F)	4
Detailed comments		<ol style="list-style-type: none"> 1. An invalid value for the parameter p_Mode has been passed to this test step, so a final inconclusive verdict is assigned, with a label indicating that a test case error has occurred. 2. If the expected behaviour occurs, then the test step completes at the leaf node, and the current preliminary verdict is not changed. 3. If unexpected / invalid behaviour occurs, and the current test step is being used as a preamble or postamble (tcv_TestBody = FALSE) then a preliminary inconclusive verdict is assigned. 4. If unexpected / invalid behaviour occurs, and the current test step is being used as part of the test purpose(tcv_TestBody = TRUE) then a preliminary failure verdict is assigned. 			

E.3.20.4 Defaults

Each behaviour line within a default behaviour table containing a preliminary verdict shall have a label of the form DFXN, where X is one of F or I for fail, and inconclusive respectively, and N is a number (with one or more digits) used to distinguish multiple DFFs, or DFIs in the same test step.

tcv_TestBody shall be referenced from within default behaviour tables to assign the appropriate verdict when unexpected events occur.

Table E10 contains an example default behaviour table illustrating these concepts.

TableE10: Example default behaviour table illustrating use of verdicts, labels and tcv_TestBody test case variable

Nr	Label	Behaviour Description	Constraints Ref	Verdict	Comments
1		L ? Response	cr_IgnoredResponse		1
2		RETURN			
3	DFI1	L ? OTHERWISE [tcv_TestBody = FALSE]		(I)	2
4	DFF1	L ? OTHERWISE [tcv_TestBody = TRUE]		(F)	3
Detailed comments		<ol style="list-style-type: none"> 1. Valid events that are to be ignored can be included in the default behaviour, but should have no preliminary verdict assigned. 2. If unexpected data is received in the preambles or postambles, a preliminary inconclusive verdict is assigned, and the test case is terminated 3. If unexpected data is received in the test body, a preliminary failure verdict is assigned, and the test case is terminated 			

[TODO: Update verdict assignment clause to include use of concurrent TTCN when required.]

See also ETR 141 clauses 11.2, 12.4, and 14.3.

E.3.21 Test suite and test case variables

A default value shall be provided for all test suite and test case variables.

[TODO: Define rules for use of test suite and test case variables, especially with regard to concurrent and modular TTCN]

E.3.22 Use of macros is forbidden

The use of macros is forbidden, to support migration to TTCN3.

E.3.23 Support for future Radio Access Technologies

To allow existing test cases to be updated in future to support other radio access technologies, test suites shall make use of a PIXIT parameter px_RAT of type RatType as shown in the following example.

Test Case Name		tc_RAT_Example1			
Nr	Label	Behaviour Description	Constraints Ref	Verdict	Comments
1		START t_Guard(300)			
2		[px_RAT = fdd]			
3		PCO ! FDD_PDU	c_FDD_PDU1		FDD specific behaviour
4	TBP1	PCO ? COMMON_PDU	c_COMMON_PDU1	(P)	
5		[px_RAT = tdd]			
6		PCO ! TDD_PDU	c_TDD_PDU1		TDD specific behaviour
7	TBP2	PCO ? COMMON_PDU	c_COMMON_PDU1	(P)	
8		[px_RAT = other_rat]		I	Tests for this RAT not implemented yet
9	TCE1	[TRUE]		I	Unexpected px_RAT value
Detailed Comments					

In general, alternatives should be used to separate behaviour specific for each RAT, and common behaviour should be re-used as much as possible. A final inconclusive verdict shall be used for any alternatives that have not been implemented yet.

Local trees may be used as shown in the following example to improve re-use of common behaviour.

Test Case Name		tc_RAT_Example2			
Nr	Label	Behaviour Description	Constraints Ref	Verdict	Comments
1		START t_Guard(300)			
2		+It_RAT_SpecificPart			
3	TBP1	PCO ? COMMON_PDU	c_COMMON_PDU1	(P)	Common behaviour
		It_RAT_SpecificPart			
4		[px_RAT = fdd]			
5		PCO ! FDD_PDU	c_FDD_PDU1		FDD specific behaviour
6		[px_RAT = tdd]			
7		PCO ! TDD_PDU	c_TDD_PDU1		TDD specific behaviour
8	TCE1	[TRUE]		(I)	Unexpected px_RAT value
Detailed Comments					

E.3.24 Managing multiple representations of the same information.

When the same information is represented using multiple types within the same test suite, it is necessary to manage conversions between the types, and ensure that the information remains consistent across all of the representations.

For example, IMSI is represented as 'SEQUENCE (SIZE (6..15)) OF Digit' in the RRC ASN.1 definitions, as a HEXSTRING for input as a PIXIT parameter, and as an information element defined in TTCN tabular format for MM.

E.3.24.1 Predefined types

Conversion operations are not required to convert the following TTCN predefined types to their counterparts in ASN.1.

- a) INTEGER predefined type
- b) BOOLEAN predefined type
- c) BITSTRING predefined type
- d) HEXSTRING predefined type
- e) OCTETSTRING predefined type
- f) OBJECTIDENTIFIER predefined type
- g) R_TYPE predefined type
- h) CharacterString predefined types

Therefore it is valid to pass a value of type BIT STRING (ASN.1) as a formal parameter of type BITSTRING (TTCN predefined).

E.3.24.2 Simple types

TR 101 666 clause 11.2.1 states:

'TTCN is a weakly typed language, in that values of any two types which have the same base type are considered to be type compatible (e.g. for the purposes of performing assignments or parameter passing).'

When simple types have restrictions, it is the TTCN author's responsibility to ensure that the restrictions are compatible. The TTCN compiler provides some assistance with this, but the extent of the checking is compiler specific.

E.3.24.3 Structured types

For conversion between more complex representations, test suite operations will generally be required. If the mapping is simple enough, it may be possible to perform the conversion using a test step, which takes the common representation as a parameter, and stores the required representation in a test case variable. This may avoid the need for an extra test suite operation.

E.3.24.4 Conversion responsibility

Two design approaches are possible for deciding where the responsibility of conversion lies: Calling party conversion and called party conversion.

The appropriate option should be selected on a case-by-case basis with the following restrictions:

- If one representation of the information is a PIXIT parameter, and this information must be passed to a test step, the called party conversion option shall be used, and the formal parameter to the test step shall always have the same type as the PIXIT parameter.
- If a test step provides multiple alternatives for different radio access technologies, which require different representations of the same information, the called party conversion convention shall be used. In this case a technology independent representation of the information shall be passed as a parameter, and the test step shall perform the conversion to the appropriate type depending on which RAT is being used.

E.3.24.5 Option 1: Calling party conversions

For this approach, each test step provides an interface based on its internal representation. It is the responsibility of the test case / step attaching the test step to perform the conversion before the attachment.

E.3.24.5.1 Advantages

- The number of calls to conversion operations is minimised.
- The complexity of the attached test steps is reduced because fewer conversions are required than for the called party conversion approach.

E.3.24.5.2 Disadvantages

- Different types are used to transfer the same information across the test step interfaces.
- The complexity of the attaching test steps / cases may be increased because conversions are required before attaching a test step.
- The attaching test steps / cases are responsible for ensuring that multiple representations contain consistent information.

E.3.24.6 Option 2: Called party conversions

In this case, the same representation is used wherever the information must be used as a formal parameter value to a test step, and it is the responsibility of the test step to perform any conversions required.

E.3.24.6.1 Advantages

- The complexity in the attaching test case / step is reduced, which will often improve readability.
- The test step interfaces are cleaner, because the same representation is always passed as a formal parameter.
- Internal representations may be hidden within test steps so that calling parties do not need to have any knowledge of them.

E.3.24.6.2 Disadvantages

- Conversion operations may be called more times than necessary, for example if the same test step is attached twice within one test case.

Annex J (informative):
Change history

Change history					
TSG T1#	Version	CR	Tdoc T	New Version	Subject/Comment
S16	100			101	