

Source: T1
Title: CR's to TS 34.122 v3.3.0 for approval
Agenda item: 5.1.3
Document for: Approval

This document contains 3 CRs to TS 34.122 v3.3.0. These CRs have been agreed by T1 and are put forward to TSG T for approval.

CRs due to test tolerance issue:

Spec	CR	Rev	Phase	Subject	Cat	Version-Current	Version-New	Doc-2 nd -Level
34.122	033		R99	New Power Classes require new test tolerances	F	3.3.0	3.4.0	T1-010154
34.122	034		R99	Test tolerances for Output Power Dynamic	F	3.3.0	3.4.0	T1-010155

CRs for creation of Rel4 specification:

Spec	CR	Rev	Phase	Subject	Cat	Version-Current	Version-New	Doc-2 nd -Level
34.122	035		Rel4	Inclusion of 1.28 Mcps TDD [Rel-4]	B	3.3.0	4.0.0	T1-010156

TSG-T WG1 meeting #11
Melbourne, Australia, 17th – 18th May 2001

T1-010154

CR-Form-v3

CHANGE REQUEST

⌘ 34.122 CR 033 ⌘ rev ⌘ Current version: 3.3.0 ⌘

For **HELP** on using this form, see bottom of this page or look at the pop-up text over the ⌘ symbols.

Proposed change affects: ⌘ (U)SIM ME/UE Radio Access Network Core Network

Title:	⌘ New Power Classes require new test tolerances		
Source:	⌘ T1/RF		
Work item code:	⌘	Date:	⌘ 14 May 2001
Category:	⌘ F	Release:	⌘ R99
Use <u>one</u> of the following categories: F (essential correction) A (corresponds to a correction in an earlier release) B (Addition of feature), C (Functional modification of feature) D (Editorial modification) Detailed explanations of the above categories can be found in 3GPP TR 21.900.		Use <u>one</u> of the following releases: 2 (GSM Phase 2) R96 (Release 1996) R97 (Release 1997) R98 (Release 1998) R99 (Release 1999) REL-4 (Release 4) REL-5 (Release 5)	

Reason for change:	⌘ Introduction of new power classes
Summary of change:	⌘ Test tolerances for new power classes.
Consequences if not approved:	⌘ No test tolerances for new power classes

Clauses affected:	⌘ 5.2.5 and Annex F4		
Other specs Affected:	<input type="checkbox"/> Other core specifications <input type="checkbox"/> Test specifications <input type="checkbox"/> O&M Specifications	⌘	
Other comments:	⌘		

5.2 User Equipment maximum output power

5.2.1 Definition and applicability

The maximum output power and its tolerance are defined according to the Power Class of the UE.

The **output power**, P_{out}, of the UE is the power when averaged (in the sense of thermal power) over the useful part of the TS at the maximum power control setting delivered in to a load with resistance equal to the nominal load impedance.

The requirements in this test apply to all UTRA – TDD- UEs

Notes copied from TS 25.102 clause 6.2.1 :

1. The maximum output power refers to.....
2. For multi-code operation the maximum output power will be reduced by the difference of peak to average ratio between single and multi-code transmission.
3. The tolerance of the maximum power is below the prescribed value even at the multi-code transmission mode
4. For UE using directive antennas for transmission, a class dependent limit will be placed on the maximum EIRP (Equivalent Isotropic Radiated Power).

5.2.2 Minimum Requirements

The error of the UE maximum output power shall not exceed the tolerance shown in Tables 5.2.2 a and b for single and multi-code.

Table 5.2.2.a: Maximum Output Power single code

Power Class	Maximum output power	Tolerance
1	+30 dBm	+1dB/-3dB
2	+24 dBm	+1dB /-3dB
3	+21 dBm	+2dB /-2dB
4	+10 dBm	+4dB/-4dB

Table 5.2.2.b: Maximum Output Power multi code

Power Class	Maximum output power	Tolerance
1	[+27 ⁻¹]dBm	+1dB/-3dB
2	[21 ⁻¹] dBm	+1dB /-3dB
3	[18 ⁻¹] dBm	+2dB /-2dB
4	[+7 ⁻¹] dBm	+4dB/-4dB

Note 1: These figures are not mentioned in 25.102. Instead there is a note, saying:
 “For multi-code operation the maximum output power will be reduced by the difference of peak to average ratio between single and multi-code transmission.”
 The figures are calculated from maximum output power single code (table 5.2.2.a) and UL multicode reference measurement channel (12.2 kbit/s) (annex C.2.2.) containing two code signals with equal level.

The normative reference for this requirement is 25.102 clause 6.2.

5.2.3 Test purpose

For the following reasons:

Limit interference.

Verify that the maximum output power is achievable.

It is the purpose of the test to verify that the UE’s maximum output power is within its tolerance limits under all environmental conditions.

5.2.4 Method of test

5.2.4.1 Initial conditions

- 1) Connect the SS to the UE antenna connector as shown in Figure A.1.
- 2) Calls are set up according to the Generic call setup procedure using parameters as specified in Tables 5.2.4.a and b
- 3) Enter the UE into loopback test mode and start the loopback test.

Table 5.2.4.a: Test parameters for Maximum Output Power single code

Parameter	Value/description
UL Reference measurement channel	12.2kbps, according to annex C.2.1
Uplink Power Control	SS level and signalling values such that UE transmits maximum power.
Data content	real life (sufficient irregular)

Table 5.2.4.b: Test parameters for Maximum Output Power multicode

Parameter	Value/description
Reference measurement channel	Multicode 12.2kbps, according to annex C.2.2
Uplink Power Control	SS level and signalling values such that UE transmits maximum power
Data content	real life (sufficient irregular)

5.2.4.2 Procedure

- 1) Measure thermal power over the useful part of the burst.
with a measurement bandwidth of at least 5 MHz.
- 2) Average over TBD time slots.
- 3) Run step 1) and 2) for RF channels Low / Mid / High

5.2.5 Test Requirements

The output power, measured in step 2) of subclause 5.2.4.2, shall not exceed the prescribed tolerance in Table 5.2.5 a and b.

Table 5.2.5.a: Maximum Output Power single code

Power Class	Maximum output power	Tolerance
1	+30 dBm	+1.7 dB/-3.7 dB
2	+24 dBm	+1.7dB /-3.7dB
3	+21 dBm	+2.7dB /-2.7dB
4	+10 dBm	+4.7 dB / -4.7 dB

Table 5.2.5.b: Maximum Output Power multi code

Power Class	Maximum output power	Tolerance
1	[27] dBm	+1.7 dB / -3.7 dB
2	[21] dBm	+1.7dB /-3.7dB
3	[18] dBm	+2.7dB /-2.7dB
4	[7] dBm	+4.7 dB / -4.7 dB

NOTE: If the above Test Requirement differs from the Minimum Requirement then the Test Tolerance applied for this test is non-zero. The Test Tolerance for this test is defined in Annex F.2 and the explanation of how the Minimum Requirement has been relaxed by the Test Tolerance is given in Annex F.4.

F.4 Derivation of Test Requirements (This subclause is informative)

The Test Requirements in this specification have been calculated by relaxing the Minimum Requirements of the core specification using the Test Tolerances defined in subclause F.2. When the Test Tolerance is zero, the Test Requirement will be the same as the Minimum Requirement. When the Test Tolerance is non-zero, the Test Requirements will differ from the Minimum Requirements, and the formula used for this relaxation is given in table F.4.

Table F.4. Derivation of Test Requirements

Test	Minimum Requirement in TS 25.102	Test Tolerance (TT)	Test Requirement in TS 34.122
5.2 Maximum Output Power	Power single code <u>Power class 1 (30 dBm)</u> <u>Tolerance = +1/-3 dB</u> Power class 2 (24 dBm) Tolerance = +1/-3 dB Power class 3 (21 dBm) Tolerance = +2/-2 dB Power multi code Power class 2 (21 dBm) Tolerance = +1/-3 dB Power class 3 (18 dBm) Tolerance = ±2 dB <u>Power class 4 (10 dBm)</u> <u>Tolerance = ± 4 dB</u>	0.7 dB	Formula: Upper Tolerance limit + TT Lower Tolerance limit – TT For power classes <u>1 and 2</u> (single and multi): Upper Tolerance limit = +1.7 dB Lower Tolerance limit = -3.7 dB For power class 3 (single and multi): Upper Tolerance limit = +2.7 dB Lower Tolerance limit = -2.7 dB <u>For power class 4 (single and multi)</u> <u>Upper Tolerance limit = +4.7 dB</u> <u>Lower Tolerance limit = -4.7 dB</u>

TSG-T WG1 meeting #11
Melbourne, Australia, 17th – 18th May 2001

T1-010155

CR-Form-v3

CHANGE REQUEST

⌘ **34.122 CR 034** ⌘ rev ⌘ Current version: **3.3.0** ⌘

For **HELP** on using this form, see bottom of this page or look at the pop-up text over the ⌘ symbols.

Proposed change affects: ⌘ (U)SIM ME/UE Radio Access Network Core Network

Title:	⌘ Test tolerances for Output Power Dynamic		
Source:	⌘ T1/RF		
Work item code:	⌘ 	Date:	⌘ 15 May 2001
Category:	⌘ F	Release:	⌘ R99
Use <u>one</u> of the following categories: F (essential correction) A (corresponds to a correction in an earlier release) B (Addition of feature), C (Functional modification of feature) D (Editorial modification) Detailed explanations of the above categories can be found in 3GPP TR 21.900.		Use <u>one</u> of the following releases: 2 (GSM Phase 2) R96 (Release 1996) R97 (Release 1997) R98 (Release 1998) R99 (Release 1999) REL-4 (Release 4) REL-5 (Release 5)	

Reason for change:	⌘ Test tolerances need to be incorporated into the test specification		
Summary of change:	⌘ Test tolerances for Output Power Dynamic incorporated		
Consequences if not approved:	⌘ missing test tolerances		

Clauses affected:	⌘ 5.4 and Annex F4 (F2 and F4)		
Other specs Affected:	<input type="checkbox"/> Other core specifications <input type="checkbox"/> Test specifications <input type="checkbox"/> O&M Specifications	⌘ 	
Other comments:	⌘ 		

5.4 Output Power Dynamics

Power control is used to limit the interference level.

5.4.1 Uplink power control

Uplink power control is the ability of the UE transmitter to sets its output power in accordance with measured downlink path loss, values determined by higher layer signalling and path loss weighting parameter α as defined in TS 25.331 [9].

The output power is defined as the average power of the transmit timeslot, and is measured with a filter that has a Root-Raised Cosine (RRC) filter response with a roll off $\alpha = 0.22$ and a bandwidth equal to the chip rate.

5.4.1.1 Initial accuracy

5.4.1.1.1 Definition and applicability

Initial Uplink power control is the ability of the UE transmitter to sets its output power in accordance with measured downlink path loss, and signalling values: I_{BTS} and Constant value, received from the BCH and applicable for the PRACH

The requirements and this test apply to all types of UTRA - UEs.

5.4.1.1.2 Conformance requirements

The UE power control, initial accuracy, is given in Table 5.4.1.1.2.

Table 5.4.1.1.2: Initial uplink power control tolerance

Normal conditions	± 9 dB
Extreme conditions	± 12 dB

The reference for this requirement is [1] TS 25.102 clause 6.4.1.1.

5.4.1.1.3 Test purpose

The power of the received signal at the UE and the BCCH information control the power of the transmitted UE signal with the target to transmit at lowest power, acceptable for proper communication.

The test stresses the ability of the receiver to measure the received power over the receiver dynamic range and to derive from this correct transmitter-power

5.4.1.1.4 Method of test

5.4.1.1.4.1 Initial conditions

Connect the SS to the MS antenna connector as shown in Figure A.1.

A call is set up according to the generic call setup procedure [3] using parameters as specified in Table 5.4.1.1.4. The RACH procedure within the call setup is used for the test.

Table 5.4.1.1.4: Test parameters for uplink Power Control

	RX-Upper dynamic end	RX-middle	RX-Sensitivity level
SS transmit power	-25 dBm/3.84 MHz	-65 dBm/3.84 MHz	-105 dBm/3.84 MHz
Broadcasted transmit-power CCPCH	35 dBm	35 dBm	24 dBm
Simulated path loss = Broadcasted TX – SS TX Power	60 dB	100 dB	129 dB
I _{BTS} (UL interference)	-75 dBm	-100 dBm	-110 dBm
Constant value	-10 dB	-10 dB	-10 dB
Nominal expected UE TX power	-25 dBm	-10 dBm	+9 dBm ²⁾

Note 1: While the SS transmit power shall cover the UE receiver input dynamic range, the logical parameters: broadcasted transmit power, I_{BTS} , and RACH constant value are chosen to achieve a UE TX power, located within the TX output power dynamic range of a class 3 UE.

Note 2: Nominal TX output power 9 dBm allows to check the uplink power control algorithm within the entire tolerance range (9 dBm +/-12 dB: 9 dBm +12 dB =21 dBm = max power class 3).

5.4.1.1.4.2 Procedure

- 1) Set the SS transmit power according to table 5.4.1.1.4.
- 2) Measure the RACH output power of the UE according to Annex B.
- 3) Repeat the test for all SS transmit powers and parameters in table 5.4.1.1.4.

5.4.1.1.5 Test requirements

The deviation with respect to the nominal expected UE TX power (table 5.4.1.1.2.) , derived in step 2, shall not exceed the prescribed tolerance in Table 5.4.1.1.5.

Table 5.4.1.1.5: Test parameters for uplink Power Control

Expected UE TX power, normal conditions	-25 dBm ±10 dB	-10 dBm±10 dB	+9 dBm ±10 dB
Expected UE TX power, extreme conditions	-25 dBm ±13 dB	-10 dBm±13 dB	+9 dBm ±13 dB

NOTE: If the above Test Requirement differs from the Minimum Requirement then the Test Tolerance applied for this test is non-zero. The Test Tolerance for this test is defined in Annex F.2 and the explanation of how the Minimum Requirement has been relaxed by the Test Tolerance is given in Annex F.4.

5.4.1.2 Differential accuracy, controlled input

5.4.1.2.1 Definition and applicability

Uplink power control, differential accuracy, is the ability of the UE transmitter to sets its output power in accordance with measured downlink path loss, and the signalling values: I_{BTS} , SIR_{Target} , Constant Value, received from higher layers and applicable for the DPCH.

Specifically, the uplink power control, differential accuracy, controlled input, is defined as the error in the UE transmitter power step as a result of a step in SIR_{TARGET} when the path loss weighting parameter $\alpha=0$, α calculated in the UE.

The requirements of this test apply to all types of UTRA -UE.

5.4.1.2.2 Conformance requirements

The step in SIR_{TARGET} shall be rounded to the closest integer dB value. The error shall not exceed the values in table 5.4.1.2.2.

Table 5.4.1.2.2.: Transmitter power step tolerance as a result of control power step

ΔSIR_{TARGET} [dB]	Transmitter power step tolerance [dB]
$\Delta SIR_{TARGET} \leq 1$	± 0.5
$1 < \Delta SIR_{TARGET} \leq 2$	± 1
$2 < \Delta SIR_{TARGET} \leq 3$	± 1.5
$3 < \Delta SIR_{TARGET} \leq 10$	± 2
$10 < \Delta SIR_{TARGET} \leq 20$	± 4
$20 < \Delta SIR_{TARGET} \leq 30$	± 6
$30 < \Delta SIR_{TARGET}$	± 9 (1)

(1) Value is given for normal conditions. For extreme conditions value is ±12

The reference for this requirement is [1] TS 25.102 clause 6.4.1.2.

5.4.1.2.3 Test purpose

It is verified if the UE sets correct uplink power steps in response to steps in the signalling value SIR_{Target} , signalled via the downlink to the UE

under the following conditions: keeping the other signalling parameters constant and deactivating any influence due to varying pathloss.

5.4.1.2.3 Method of test

5.4.1.2.3.1 Initial conditions

- 1) Connect the SS to the MS antenna connector as shown in Figure A.1.
- 2) A call is set up according to the generic call setup procedure using parameters as specified in Table 5.4.1.2.4

Table 5.4.1.2.4. Test parameters for Uplink Power Control, Differential Accuracy, Controlled Input

Parameter	Value/description
UL reference measurement channel	12.2kbps according to annex C.2.1.
BS Transmit to UE Transmit delay	7 TSS--> $\alpha=0$
SSTransmit power	[-65 dBm]
Reference transmit power broadcast on BCH	[35 dBm]
I _{BTS}	[-100]
Constant value	[-10]
Data content	real life (sufficient irregular)

5.4.1.2.3.2 Procedure

Using the SIR_{Target} -value in the downlink,

cover the UE-transmitter dynamic range by commanding the UEs power with the signalling value SIR_{Target} in a step resolution (positive and negative direction) of

- | | |
|------------------|---------------------------------------|
| 1 dB | approx. 68 steps up and 68 steps down |
| 2 dB | approx. 34 steps up and 34 steps down |
| 3 dB | approx. 22 steps up and 22 steps down |
| 10 dB | approx. 7 steps up and 7 steps down |
| 20 dB | approx. 3 steps up and 3 steps down |
| 30 dB | approx. 2 step up and 2 step down |
| maximum stepsize | 1 step up and 1 step down |

Measure the power according to Annex B.

5.4.1.2.4 Test requirements

For the UE output power laying between

Max Power minus tolerance and Min Power

the step response shall not exceed the prescribed tolerance in Table 5.4.1.2.42.

Table 5.4.1.2.4.: Transmitter power step tolerance as a result of control power step

<u>$\Delta\text{SIR}_{\text{TARGET}}$ [dB]</u>	<u>Transmitter power step tolerance [dB]</u>
<u>$\Delta\text{SIR}_{\text{TARGET}} \leq 1$</u>	<u>± 0.6</u>
<u>$1 < \Delta\text{SIR}_{\text{TARGET}} \leq 2$</u>	<u>± 1.15</u>
<u>$2 < \Delta\text{SIR}_{\text{TARGET}} \leq 3$</u>	<u>± 1.7</u>
<u>$3 < \Delta\text{SIR}_{\text{TARGET}} \leq 10$</u>	<u>± 2.5</u>
<u>$10 < \Delta\text{SIR}_{\text{TARGET}} \leq 20$</u>	<u>± 4.7</u>
<u>$20 < \Delta\text{SIR}_{\text{TARGET}} \leq 30$</u>	<u>± 6.7</u>
<u>$30 < \Delta\text{SIR}_{\text{TARGET}}$</u>	<u>± 10</u>

NOTE: If the above Test Requirement differs from the Minimum Requirement then the Test Tolerance applied for this test is non-zero. The Test Tolerance for this test is defined in Annex F.2 and the explanation of how the Minimum Requirement has been relaxed by the Test Tolerance is given in Annex F.4.

Annex F (normative): General test conditions and declarations

The requirements of this clause apply to all applicable tests in this specification.

Many of the tests in this specification measure a parameter relative to a value that is not fully specified in the UE specifications. For these tests, the Minimum Requirement is determined relative to a nominal value specified by the manufacturer.

When specified in a test, the manufacturer shall declare the nominal value of a parameter, or whether an option is supported.

.In all the relevant subclauses in this clause all Bit Error Ratio (BER), Block Error Ratio (BLER) measurements shall be carried out according to the general rules for statistical testing in annex F.6.

F.1 Acceptable uncertainty of Test System

The maximum acceptable uncertainty of the Test System is specified below for each test, where appropriate. The Test System shall enable the stimulus signals in the test case to be adjusted to within the specified range, and the equipment under test to be measured with an uncertainty not exceeding the specified values. All tolerances and uncertainties are absolute values, and are valid for a confidence level of 95 %, unless otherwise stated.

A confidence level of 95% is the measurement uncertainty tolerance interval for a specific measurement that contains 95% of the performance of a population of test equipment.

For RF tests it should be noted that the uncertainties in subclause F.1 apply to the Test System operating into a nominal 50 ohm load and do not include system effects due to mismatch between the DUT and the Test System.

F.1.1 Measurement of test environments

The measurement accuracy of the UE test environments defined in Annex G, Test environments shall be.

- Pressure ± 5 kPa.
- Temperature ± 2 degrees.
- Relative Humidity ± 5 %.
- DC Voltage $\pm 1,0$ %.
- AC Voltage $\pm 1,5$ %.
- Vibration 10 %.
- Vibration frequency 0,1 Hz.

The above values shall apply unless the test environment is otherwise controlled and the specification for the control of the test environment specifies the uncertainty for the parameter.

F.1.2 Measurement of transmitter

Table F.1.2 Maximum Test System Uncertainty for transmitter tests

Subclause	Maximum Test System Uncertainty
5.2 UE Maximum Output Power	±0.7 dB
5.3 Frequency Stability	± 10Hz
5.4.1 Uplink power control	Relative ±[0.3] dB
5.4.2 Minimum Transmit Power	±1.0 dB
5.4.3 Transmit OFF Power	±1.5 dB
5.4.4 Transmit ON/OFF Power	TBD
5.4.5 Out-of-synchronisation handling of output power	TBD
5.5.1 Occupied Bandwidth	±100 kHz
5.5.2.1 Spectrum emission mask	±1.5 dB
5.5.2.2 ACLR	5 MHz offset: ± 0.8 dB 10 MHz offset: ± 0.8 dB
5.5.3 Spurious emissions	± 2.0 dB for UE and coexistence bands for results > -60 dBm ± 3.0 dB for results < -60 dBm Outside above: f ≤ 2.2GHz : ± 1.5 dB 2.2 GHz < f ≤ 4 GHz : ± 2.0 dB f > 4 GHz : ±4.0 dB
5.6 Transmit intermodulation:	Will be based on BS, need to work out freq and level ranges.
5.7.1 Transmit modulation: EVM	±2.5 %
5.7.2 Transmit modulation: peak code domain error	±1 dB

F.1.3 Measurement of receiver

Table F.1.3 Maximum Test System Uncertainty for receiver tests

Subclause	Maximum Test System Uncertainty
6.2 Reference Sensitivity Level	± 0.7 dB
6.3 maximum input level:	TBD
6.4 Adjacent Channel Selectivity (ACS)	Overall system uncertainty ± 1.1 dB
6.5 Blocking Characteristics	Using ± 0.7 dB for signal and interferer as currently defined, and 68 dB ACLR @ 10 MHz. System error with f < 15 MHz offset: ± 1.4 dB f ≥ 15 MHz offset and f ≤ 2.2 GHz: ± [1.0] dB 2.2 GHz < f ≤ 4 GHz : ±[1.7] dB f > 4 GHz: ±[3.1] dB
6.6 Spurious Response	f < 2.2 GHz: ±1.0dB 2.2 < f < 4GHz: ±1.7dB f > 4 GHz: ±3.1dB
6.7 Intermodulation Characteristics	Assume ± 0.7 dB for all signals. Overall uncertainty = ± [0.6] dB Needs further analysis
6.8 Spurious Emissions	± 3.0 dB for UE receive band (-78 dBm) Outside above: f ≤ 2.2GHz : ± 2.0dB (-57 dBm) 2.2 GHz < f ≤ 4 GHz : ± 2.0 dB (-47 dBm) f > 4 GHz : ±4.0 dB (-47 dBm)

F.1.4 Performance requirement

Table F.1.4 Maximum Test System Uncertainty for Performance Requirements

Subclause	Maximum Test System Uncertainty
TBD	TBD

F.1.5 Requirements for support of RRM

TBD

F.2 Test Tolerances (This subclause is informative)

The Test Tolerances defined in this subclause have been used to relax the Minimum Requirements in this specification to derive the Test Requirements.

The Test Tolerances are derived from Test System uncertainties, regulatory requirements and criticality to system performance. As a result, the Test Tolerances may sometimes be set to zero.

The test tolerances should not be modified for any reason e.g. to take account of commonly known test system errors (such as mismatch, cable loss, etc.).

F.2.1 Transmitter

Table F.2.1 Test Tolerances for transmitter tests.

Subclause	Test Tolerance
5.2 Maximum Output Power	0.7 dB
5.3 UE Frequency Stability	10 Hz
5.4.1.1 Uplink Power Control, Initial Accuracy	+1.0 dB
5.4.1.2 Uplink Power Control, differential Accuracy	1dB step: 0.1 dB 2 dB step: 0.15 dB 3dB step: 0.2 dB 10 dB step: 0.5 dB 20 dB step: 0.7 dB 30 dB step: 0.7 dB >30 dB step: 1.0 dB
5.4.2 Minimum Transmit Power	1.0 dB
5.4.5 Out-of-synchronisation handling of output power: $\frac{DPCCH - E_c}{I_{or}}$	[0.3] dB
5.4.5 Out-of-synchronisation handling of output power: transmit ON/OFF time	0 ms
5.5.1 Transmit OFF power	1.5 dB
5.5.1 Occupied Bandwidth	0 kHz
5.5.2.1 Spectrum emission mask	1.5 dB
5.5.2.2 Adjacent Channel Leakage Power Ratio (ACLR)	0.8 dB
5.5.3 Spurious Emissions	0 dB
5.6 Transmit Intermodulation	0 dB
5.7.1 Error Vector Magnitude	0%
5.7.2 Peak code domain error	1.0 dB

F.2.2 Receiver

Table F.2.2 Test Tolerances for receiver tests.

Subclause	Test Tolerance
6.2 Reference sensitivity level	0.7 dB
6.4 Adjacent channel selectivity	0 dB
6.5 Blocking characteristics	0 dB
6.6 Spurious Response	0 dB
6.7 Intermodulation Characteristics	0 dB
6.8 Spurious emissions	0 dB

F.2.3 Performance requirements

Table F.2.3 Test Tolerances for Performance Requirements.

Subclause	Test Tolerance
7.2, Demodulation in Static Propagation Condition	
7.3, Demodulation of DCH in Multiplath Fading conditions	
7.4, Base Station Transmit diversity modes	

F.2.4 Requirements for support of RRM

TBD

F.3 Interpretation of measurement results

The measurement results returned by the Test System are compared - without any modification - against the Test Requirements as defined by the shared risk principle.

The Shared Risk principle is defined in ETR 273 Part 1 sub-part 2 section 6.5.

The actual measurement uncertainty of the Test System for the measurement of each parameter shall be included in the test report.

The recorded value for the Test System uncertainty shall be, for each measurement, equal to or lower than the appropriate figure in subclause F.1 of this specification.

If the Test System for a test is known to have a measurement uncertainty greater than that specified in subclause F.1, it is still permitted to use this apparatus provided that an adjustment is made value as follows.

Any additional uncertainty in the Test System over and above that specified in subclause F.1 shall be used to tighten the Test Requirement – making the test harder to pass. (For some tests e.g. receiver tests, this may require modification of stimulus signals). This procedure will ensure that a Test System not compliant with subclause F.1 does not increase the chance of passing a device under test where that device would otherwise have failed the test if a Test System compliant with subclause F.1 had been used.

F.4 Derivation of Test Requirements (This subclause is informative)

The Test Requirements in this specification have been calculated by relaxing the Minimum Requirements of the core specification using the Test Tolerances defined in subclause F.2. When the Test Tolerance is zero, the Test Requirement will be the same as the Minimum Requirement. When the Test Tolerance is non-zero, the Test Requirements will differ from the Minimum Requirements, and the formula used for this relaxation is given in table F.4.

Table F.4. Derivation of Test Requirements

Test	Minimum Requirement in TS 25.102	Test Tolerance (TT)	Test Requirement in TS 34.122																								
5.2 Maximum Output Power	Power single code Power class 2 (24 dBm) Tolerance = +1/-3 dB Power class 3 (21 dBm) Tolerance = +2/-2 dB Power multi code Power class 2 (21 dBm) Tolerance = +1/-3 dB Power class 3 (18 dBm) Tolerance = ±2 dB	0.7 dB	Formula: Upper Tolerance limit + TT Lower Tolerance limit – TT For power classes 2 (single and multi): Upper Tolerance limit = +1.7 dB Lower Tolerance limit = -3.7 dB For power class 3 (single and multi): Upper Tolerance limit = +2.7 dB Lower Tolerance limit = -2.7 dB																								
5.3 UE Frequency Stability	The UE modulated carrier frequency shall be accurate to within ±0.1 ppm compared to the carrier frequency received from the Node B.	10 Hz	Formula: modulated carrier frequency error + TT modulated carrier frequency error = ±(0.1 ppm + 10 Hz).																								
<u>5.4.1.1 Uplink Pwr Control, Initial accuracy</u>	<u>± 9dB normal conditions</u> <u>± 12dB extreme conditions</u>	<u>1.0 dB</u>	<u>Formula: Upper Tolerance limit + TT</u> <u>Lower Tolerance limit – TT</u> <u>Nominal expected TX power</u> <u>± 10dB (normal conditions)</u> <u>± 13dB (extreme conditions)</u>																								
<u>5.4.1.2 Uplink Power Control, differential accuracy</u>	<table border="0"> <tr> <td><u>SIR Target</u></td> <td><u>Pow Step Tol</u></td> </tr> <tr> <td><u><1 dB</u></td> <td><u>0.5 dB</u></td> </tr> <tr> <td><u><2dB</u></td> <td><u>1 dB</u></td> </tr> <tr> <td><u><3 dB</u></td> <td><u>1.5 dB</u></td> </tr> <tr> <td><u><10 dB</u></td> <td><u>2 dB</u></td> </tr> <tr> <td><u><20dB</u></td> <td><u>4 dB</u></td> </tr> <tr> <td><u><30 dB</u></td> <td><u>6 dB</u></td> </tr> <tr> <td><u>> 30 dB</u></td> <td><u>9 dB</u></td> </tr> </table>	<u>SIR Target</u>	<u>Pow Step Tol</u>	<u><1 dB</u>	<u>0.5 dB</u>	<u><2dB</u>	<u>1 dB</u>	<u><3 dB</u>	<u>1.5 dB</u>	<u><10 dB</u>	<u>2 dB</u>	<u><20dB</u>	<u>4 dB</u>	<u><30 dB</u>	<u>6 dB</u>	<u>> 30 dB</u>	<u>9 dB</u>	<table border="0"> <tr> <td><u>TT</u></td> </tr> <tr> <td><u>0.1 dB</u></td> </tr> <tr> <td><u>0.15 dB</u></td> </tr> <tr> <td><u>0.2 dB</u></td> </tr> <tr> <td><u>0.5 dB</u></td> </tr> <tr> <td><u>0.7 dB</u></td> </tr> <tr> <td><u>0.7 dB</u></td> </tr> <tr> <td><u>1.0 dB</u></td> </tr> </table>	<u>TT</u>	<u>0.1 dB</u>	<u>0.15 dB</u>	<u>0.2 dB</u>	<u>0.5 dB</u>	<u>0.7 dB</u>	<u>0.7 dB</u>	<u>1.0 dB</u>	<u>Formula: Upper Tolerance limit + TT</u> <u>Lower Tolerance limit – TT</u>
<u>SIR Target</u>	<u>Pow Step Tol</u>																										
<u><1 dB</u>	<u>0.5 dB</u>																										
<u><2dB</u>	<u>1 dB</u>																										
<u><3 dB</u>	<u>1.5 dB</u>																										
<u><10 dB</u>	<u>2 dB</u>																										
<u><20dB</u>	<u>4 dB</u>																										
<u><30 dB</u>	<u>6 dB</u>																										
<u>> 30 dB</u>	<u>9 dB</u>																										
<u>TT</u>																											
<u>0.1 dB</u>																											
<u>0.15 dB</u>																											
<u>0.2 dB</u>																											
<u>0.5 dB</u>																											
<u>0.7 dB</u>																											
<u>0.7 dB</u>																											
<u>1.0 dB</u>																											

CR-Form-v3

CHANGE REQUEST

⌘ **34.122 CR 035** ⌘ rev **-** ⌘ Current version: **3.3.0** ⌘

For **HELP** on using this form, see bottom of this page or look at the pop-up text over the ⌘ symbols.

Proposed change affects: ⌘ (U)SIM ME/UE Radio Access Network Core Network

Title:	⌘ Inclusion of 1.28 Mcps TDD in TS 34.122		
Source:	⌘ T1/RF		
Work item code:	⌘ LCRTDD-RF-TEST	Date:	⌘ 2001-05-10
Category:	⌘ B	Release:	⌘ REL-4
Use <u>one</u> of the following categories: F (essential correction) A (corresponds to a correction in an earlier release) B (Addition of feature), C (Functional modification of feature) D (Editorial modification) Detailed explanations of the above categories can be found in 3GPP TR 21.900.		Use <u>one</u> of the following releases: 2 (GSM Phase 2) R96 (Release 1996) R97 (Release 1997) R98 (Release 1998) R99 (Release 1999) REL-4 (Release 4) REL-5 (Release 5)	

Reason for change:	⌘ Include 1.28 Mcps TDD option into UE conformance test specifications		
Summary of change:	⌘ Test case descriptions for 1.28 Mcps TDD option		
Consequences if not approved:	⌘ 1.28 Mcps TDD option is not tested properly		

Clauses affected:	⌘ 1, 2, 4, 5, 6, 7, C, D, F.2		
Other specs affected:	<input type="checkbox"/> Other core specifications <input type="checkbox"/> Test specifications <input type="checkbox"/> O&M Specifications	⌘	
Other comments:	⌘		

How to create CRs using this form:

Comprehensive information and tips about how to create CRs can be found at: http://www.3gpp.org/3G_Specs/CRs.htm. Below is a brief summary:

- 1) Fill out the above form. The symbols above marked ⌘ contain pop-up help information about the field that they are closest to.
- 2) Obtain the latest version for the release of the specification to which the change is proposed. Use the MS Word "revision marks" feature (also known as "track changes") when making the changes. All 3GPP specifications can be downloaded from the 3GPP server under <ftp://www.3gpp.org/specs/>. For the latest version, look for the directory name with the latest date e.g. 2000-09 contains the specifications resulting from the September 2000 TSG meetings.
- 3) With "track changes" disabled, paste the entire CR form (use CTRL-A to select it) into the specification just in front of the clause containing the first piece of changed text. Delete those parts of the specification which are not relevant to the change request.

3GPP TS 34.122 V3.3.0 (2001-03)

Technical Specification

**3rd Generation Partnership Project;
Technical Specification Group Terminal;
Terminal Conformance Specification;
Radio transmission and reception (TDD)
(Release 1999)**



The present document has been developed within the 3rd Generation Partnership Project (3GPP™) and may be further elaborated for the purposes of 3GPP. The present document has not been subject to any approval process by the 3GPP Organisational Partners and shall not be implemented. This Specification is provided for future development work within 3GPP only. The Organisational Partners accept no liability for any use of this Specification. Specifications and reports for implementation of the 3GPP™ system should be obtained via the 3GPP Organisational Partners' Publications Offices.

Keywords

UMTS, testing, terminal

Keywords

terminal, testing, UMTS

3GPP

Postal address

3GPP support office address

650 Route des Lucioles - Sophia Antipolis
Valbonne - FRANCE
Tel.: +33 4 92 94 42 00 Fax: +33 4 93 65 47 16

Internet

<http://www.3gpp.org>

Copyright Notification

No part may be reproduced except as authorized by written permission.
The copyright and the foregoing restriction extend to reproduction in all media.

© 2001, 3GPP Organizational Partners (ARIB, CWTS, ETSI, T1, TTA, TTC).
All rights reserved.

Contents

Foreword.....	17
1 Scope.....	18
2 References.....	18
3 Definitions, abbreviations and equations.....	18
3.1 Definitions.....	18
3.2 Abbreviations.....	19
3.3 Equations.....	19
4 Frequency bands and channel arrangement.....	19
4.1 General.....	19
4.2 Frequency bands.....	19
4.3 TX–RX frequency separation.....	20
4.3.2 1.28 Mcps TDD Option.....	20
4.4 Channel arrangement.....	20
4.4.1 Channel spacing.....	20
4.4.1.2 1.28 Mcps TDD Option.....	20
4.4.2 Channel raster.....	20
4.4.3 Channel number.....	20
5 Transmitter Characteristics.....	20
5.1 General.....	20
5.2 User Equipment maximum output power.....	21
5.2.1 Definition and applicability.....	21
5.2.2 Minimum Requirements.....	21
5.2.3 Test purpose.....	22
5.2.4 Method of test.....	22
5.2.4.1 Initial conditions.....	22
5.2.4.2 Procedure.....	23
5.2.5 Test Requirements.....	23
5.3 UE frequency stability.....	24
5.3.1 Definition and applicability.....	24
5.3.2 Minimum Requirements.....	24
5.3.3 Test purpose.....	24
5.3.4 Method of test.....	24
5.3.4.1 Initial conditions.....	24
5.3.4.1.1 3.84 Mcps TDD Option.....	24
5.3.4.1.2 1.28 Mcps TDD Option.....	25
5.3.4.2 Procedure.....	25
5.3.5 Test Requirements.....	25
5.4 Output Power Dynamics.....	25
5.4.1 Uplink power control.....	25
5.4.1.1 Initial accuracy (3.84 Mcps TDD Option).....	26
5.4.1.1.1 Definition and applicability.....	26
5.4.1.1.2 Minimum requirements.....	26
5.4.1.1.3 Test purpose.....	26
5.4.1.1.4 Method of test.....	26
5.4.1.1.4.1 Initial conditions.....	26
5.4.1.1.4.2 Procedure.....	27
5.4.1.1.5 Test requirements.....	27
5.4.1.2 Differential accuracy, controlled input (3.84 Mcps TDD Option).....	27
5.4.1.2.1 Definition and applicability.....	27
5.4.1.2.2 Minimum requirements.....	27
5.4.1.2.3 Test purpose.....	27
5.4.1.2.4 Method of test.....	28
5.4.1.2.4.1 Initial conditions.....	28
5.4.1.2.4.2 Procedure.....	28

5.4.1.2.5	Test requirements	28
5.4.1.3	Open loop power control (1.28 Mcps TDD Option).....	28
5.4.1.3.2	Minimum requirements	29
5.4.1.4	Closed loop power control (1.28 Mcps TDD Option)	29
5.4.1.4.2	Minimum requirements	29
5.4.2	Minimum transmit output power	32
5.4.2.1	Definition and applicability	32
5.4.2.2	Minimum Requirements	32
5.4.2.2.2	1.28Mcps TDD Option.....	32
5.4.2.3	Test purpose.....	32
5.4.2.4	Method of test.....	32
5.4.2.4.1	Initial conditions.....	32
5.4.2.4.2	Procedure	32
5.4.2.5	Test requirements.....	33
5.4.3	Transmit OFF power.....	33
5.4.3.1	Definition and applicability	33
5.4.3.2	Minimum Requirements	33
5.4.3.3	Test purpose.....	33
5.4.3.4	Method of test.....	33
5.4.3.5	Test requirements.....	33
5.4.4	Transmit ON/OFF Time mask	33
5.4.4.1	Definition and applicability	33
5.4.4.2	Minimum requirements.....	34
5.4.4.2.1	3.84Mcps TDD Option.....	34
5.4.4.2.2	1.28Mcps TDD Option.....	34
5.4.4.3	Test Purpose	35
5.4.4.4	Method of test.....	35
5.4.4.4.1	Initial conditions.....	35
5.4.4.4.2	Procedure	35
5.4.4.5	Test requirements.....	35
5.4.5	Out-of-synchronisation handling of output power.....	35
5.4.5.1	Definition and applicability	35
5.4.5.2	Minimum Requirement.....	35
5.4.5.3	Test purpose.....	38
5.4.5.4	Method of test.....	38
5.4.5.4.1	Initial conditions.....	38
5.4.5.4.2	Procedure	38
5.4.5.5	Test Requirements	39
5.5	Output RF spectrum emissions.....	39
5.5.1	Occupied bandwidth	39
5.5.1.1	Definition and applicability	39
5.5.1.2	Minimum Requirements	39
5.5.1.2.2	1.28Mcps TDD Option	39
5.5.1.3	Test purpose.....	39
5.5.1.4	Method of test.....	40
5.5.1.4.1	Initial conditions.....	40
5.5.1.4.2	Procedure	40
5.5.1.5	Test requirements.....	40
5.5.2	Out of band emission	40
5.5.2.1	Spectrum emission mask	41
5.5.2.1.1	Definition and applicability.....	41
5.5.2.1.2	Minimum Requirements.....	41
5.5.2.1.2.1	3.84 Mcps TDD Option	41
5.5.2.1.2.2	1.28 Mcps TDD Option	41
5.5.2.1.3	Test purpose	42
5.5.2.1.4	Method of test	42
5.5.2.1.5	Test requirements	42
5.5.2.2	Adjacent Channel Leakage power Ratio (ACLR)	43
5.5.2.2.1	Definition and applicability.....	43
5.5.2.2.2	Minimum Requirements.....	43
5.5.2.2.2.2	1.28Mcps TDD Option.....	44

5.5.2.2.3	Test purpose	44
5.5.2.2.4	Method of test	44
5.5.2.2.5	Test requirements	45
5.5.3	Spurious emissions	45
5.5.3.1	Definition and applicability	45
5.5.3.2	Minimum Requirements	45
5.5.3.2.2	1.28Mcps TDD Option	46
5.5.3.3	Test purpose.....	47
5.5.3.4	Method of test.....	47
5.5.3.4.1	Initial conditions.....	47
5.5.3.4.2	Procedure	47
5.5.3.5	Test requirements.....	47
5.6	Transmit Intermodulation.....	48
5.6.1	Definition and applicability	48
5.6.2	Minimum Requirements	48
5.6.2.2	1.28 Mcps TDD Option	49
5.6.3	Test purpose.....	49
5.6.4	Method of test.....	49
5.6.4.1	Initial conditions	49
5.6.4.2	Procedure.....	49
5.6.5	Test requirements.....	50
5.6.5.2	1.28 Mcps TDD Option	50
5.7	Transmit Modulation.....	51
5.7.1	Error Vector Magnitude.....	51
5.7.1.1	Definition and applicability	51
5.7.1.2	Minimum Requirements	51
5.7.1.3	Test purpose.....	51
5.7.1.4	Method of test	51
5.7.1.4.1	Initial conditions.....	51
5.7.1.4.2	Procedure	51
5.7.1.5	Test requirements.....	51
5.7.2	Peak code domain error	52
5.7.2.1	Definition and applicability	52
5.7.2.2	Minimum Requirement.....	52
5.7.2.3	Test purpose.....	52
5.7.2.4	Method of test.....	52
5.7.2.4.1	Initial conditions.....	52
5.7.2.4.2	Procedure	53
5.7.2.5	Test requirements.....	53
6	Receiver Characteristics	53
6.1	General	53
6.2	Reference sensitivity level.....	54
6.2.1	Definition and applicability	54
6.2.2	Minimum Requirements	54
6.2.2.2	1.28 Mcps TDD Option	54
6.2.3	Test purpose.....	54
6.2.4	Method of test.....	55
6.2.4.1	Initial conditions	55
6.2.4.2	Procedure.....	55
6.2.5	Test requirements.....	55
6.3	Maximum Input Level.....	56
6.3.1	Definition and applicability	56
6.3.2	Minimum requirements.....	56
6.3.2.1	3.84 Mcps TDD Option	56
6.3.2.2	1.28 Mcps TDD Option	56
6.3.3	Test purpose.....	56
6.3.4	Method of test.....	57
6.3.4.1	Initial conditions	57
6.3.4.2	Procedure.....	57
6.3.5	Test requirements.....	57
6.4	Adjacent Channel Selectivity (ACS).....	57

6.4.1	Definition and applicability	57
6.4.2	Minimum Requirements	57
6.4.2.1	3.84 Mcps TDD Option	57
6.4.2.2	1.28 Mcps TDD Option	58
6.4.3	Test purpose.....	58
6.4.4	Method of test.....	58
6.4.4.1	Initial conditions	58
6.4.4.2	Procedure.....	59
6.4.5	Test Requirements	59
6.5	Blocking Characteristics.....	60
6.5.1	Definition and applicability	60
6.5.2	Minimum Requirements	60
6.5.2.1	3.84 Mcps TDD Option	60
6.5.2.2	1.28 Mcps TDD Option	61
6.5.3	Test purpose.....	62
6.5.4	Method of test.....	62
6.5.4.1	Initial conditions	62
6.5.4.2	Procedure.....	63
6.5.5	Test requirements.....	63
6.6	Spurious Response	64
6.6.1	Definition and applicability	64
6.6.2	Minimum Requirements	64
6.6.2.2	1.28 Mcps TDD Option	65
6.6.3	Test purpose.....	65
6.6.4	Method of test.....	65
6.6.4.1	Initial conditions	65
6.6.4.2	Procedure.....	65
6.6.5	Test requirements.....	66
6.7	Intermodulation Characteristics.....	66
6.7.1	Definition and applicability	66
6.7.2	Minimum Requirements	67
6.7.2.1	3.84 Mcps TDD Option	67
6.7.2.2	1.28 Mcps TDD Option	67
6.7.3	Test purpose.....	67
6.7.4	Method of test.....	67
6.7.4.1	Initial conditions	67
6.7.4.2	Procedure.....	68
6.7.5	Test requirements.....	68
6.8	Spurious Emissions	69
6.8.1	Definition and applicability	69
6.8.2	Minimum Requirements	69
6.8.2.1	3.84 Mcps TDD Option	69
6.8.2.2	1.28 Mcps TDD Option	69
6.8.3	Test purpose.....	70
6.8.4	Method of test.....	70
6.8.4.1	Initial conditions	70
6.8.4.2	Procedure.....	70
6.8.5	Test requirements.....	70
7	Performance Requirements.....	72
7.1	General	72
7.2	Demodulation in static propagation conditions	72
7.2.1	Demodulation of DCH.....	72
7.2.1.1	Definition and applicability	72
7.2.1.2	Minimum requirements.....	72
7.2.1.2.1	3.84 Mcps TDD Option	72
7.2.1.2.2	1.28 Mcps TDD Option	73
7.2.1.3	Test purpose.....	74
7.2.1.4	Method of test.....	74
7.2.1.4.1	Initial conditions.....	74
7.2.1.4.2	Procedure	74

7.2.1.5	Test requirements.....	74
7.3	Demodulation of DCH in multipath fading conditions	74
7.3.1	Multipath fading Case 1.....	74
7.3.1.1	Definition and applicability	74
7.3.1.2	Minimum requirements.....	74
7.3.1.2.2	1.28 Mcps TDD Option	75
7.3.1.3	Test purpose.....	76
7.3.1.4	Method of test.....	76
7.3.1.4.1	Initial conditions.....	76
7.3.1.4.2	Procedure	76
7.3.1.5	Test requirements.....	77
7.3.2	Multipath fading Case 2.....	77
7.3.2.1	Definition and applicability	77
7.3.2.2	Minimum requirement	77
7.3.2.2.1	3.84 Mcps TDD Option.....	77
7.3.2.2.2	1.28 Mcps TDD Option.....	78
7.3.2.3	Test purpose.....	79
7.3.2.4	Method of test.....	79
7.3.2.4.1	Initial conditions.....	79
7.3.2.4.2	Procedure	79
7.3.2.5	Test requirements.....	79
7.3.3	Multipath fading Case 3.....	79
7.3.3.1	Definition and applicability	79
7.3.3.2	Minimum requirements.....	79
7.3.3.2.2	1.28 Mcps TDD Option	81
7.3.3.3	Test purpose.....	82
7.3.3.4	Method of test.....	82
7.3.3.4.1	Initial conditions.....	82
7.3.3.4.2	Procedure	82
7.3.3.5	Test requirements.....	82
7.4	Base station transmit diversity mode for 3.84 Mcps TDD Option	82
7.4.1	Demodulation of BCH in Block STTD mode.....	82
7.4.1.1	Minimum requirements.....	82
7.5	Power control in downlink for 3.84 Mcps TDD Option.....	83
7.5.1	Minimum requirements.....	83
8	Requirements for Support of RRM.....	83
8.1	General	83
8.2	Idle Mode Tasks	84
8.2.1	Introduction.....	84
8.2.2	RF Cell Selection Scenario	84
8.2.2.1	Requirements for Cell Selection single carrier single cell case	84
8.2.2.2	Requirements for Cell Selection multicarrier carrier multi cell case	84
8.2.3	RF Cell Re-Selection Scenario	84
8.2.3.1	Requirements for Cell Re-Selection single carrier multi cell case.....	84
8.2.4	PLMN Selection and Re-Selection Scenario	84
8.2.5	Location Registration Scenario.....	84
8.3	RRC Connection mobility	84
8.3.1	Handover	84
8.3.1.1	Introduction.....	84
8.3.1.2	Handover 3G to 3G.....	84
8.3.1.2.1	TDD/TDD Handover	84
8.3.1.2.2	TDD/FDD Handover.....	84
8.3.1.3	Handover 3G to 2G.....	84
8.3.1.3.1	Handover to GSM	84
8.3.2	Radio Link Management	85
8.3.2.1	Link adaptation	85
8.3.3	Cell Update	85
8.3.4	URA Update	85
8.4	RRC Connection Control	85
8.4.1	Radio Access Bearer Control.....	85
8.5	Dynamic Channel Allocation	85

8.6	Timing characteristics	85
8.6.1	Timing Advance (TA) Requirements	85
8.7	Measurements Performance Requirements	85
8.7.1	Measurements Performance for UE	85
Annex A (informative): Connection Diagrams.....		86
Annex B (normative): Global In-Channel TX-Test		90
B.1	General.....	90
B.2	Definition of the process.....	90
B.2.1	Basic principle	90
B.2.2	Output signal of the TX under test.....	90
B.2.3	Reference signal.....	90
B.2.4	void	91
B.2.5	Classification of measurement results.....	91
B.2.6	Process definition to achieve results of type "deviation".....	91
B.2.7	Process definition to achieve results of type "residual"	92
B.2.7.1	Error Vector Magnitude (EVM)	92
B.2.7.2	Peak Code Domain Error (PCDE)	92
B.3	Notes	93
Annex C (normative): Measurement channels.....		95
C.1	General.....	95
C.2	UL Reference measurement channels.....	95
C.2.1	UL reference measurement channel (12.2 kbps)	95
C.2.1.2	UL reference measurement channel (12.2 kbps) for 1.28 Mcps TDD Option	96
C.2.2	UL multi code reference measurement channel (12.2 kbps).....	97
C.2.2.2	UL multi code reference measurement channel (12.2 kbps) for 1.28 Mcps TDD Option	99
C.2.3	UL reference measurement channel (64 kbps)	100
C.2.4	UL reference measurement channel (144 kbps)	102
C.2.5	UL reference measurement channel (384 kbps)	103
C.3	DL Reference measurement channels.....	104
C.3.1	DL reference measurement channel (12.2 kbps)	104
C.3.1.2	DL reference measurement channel (12.2 kbps) for 1.28 Mcps TDD Option	106
C.3.2	DL reference measurement channel (64 kbps)	107
C.3.2.2	DL reference measurement channel (64 kbps) for 1.28 Mcps TDD Option	109
C.3.3	DL reference measurement channel (144 kbps)	110
C.3.3.2	DL reference measurement channel (144 kbps) for 1.28 Mcps TDD Option	112
C.3.4	DL reference measurement channel (384 kbps)	113
C.3.4.2	DL reference measurement channel (384 kbps) for 1.28 Mcps TDD Option	115
C.3.5	BCH reference measurement channel.....	116
C.3.5.2	BCH reference measurement channel (12.3 kbps) for 1.28 Mcps TDD Option	117
C.3.6	DL reference measurement channel (2 Mbps) for 3.84 Mcps TDD Option	117
Annex D (normative): Propagation conditions.....		119
D.1	Test Environments	119
D.2	Propagation Conditions.....	119
D.2.1	Static propagation condition	119
D.2.2	Multi-path fading propagation conditions.....	119
D.2.2.2	1.28 Mcps TDD Option	120

Annex E (normative): Common RF test conditions	121
E.1 General.....	121
E.2 Connection Set-up.....	121
E.3 During connection.....	121
E.3.1 Measurement of Tx Characteristics	121
E.3.2 Measurement of Rx Characteristics	122
E.3.3 Measurement of Performance requirements	122
Annex F (normative): General test conditions and declarations	123
F.1 Acceptable uncertainty of Test System.....	123
F.1.1 Measurement of test environments	123
F.1.2 Measurement of transmitter	124
F.1.3 Measurement of receiver	125
F.1.4 Performance requirement.....	125
F.1.5 Requirements for support of RRM	125
F.2 Test Tolerances (This subclause is informative)	125
F.2.1 Transmitter.....	126
F.2.2 Receiver	126
F.2.3 Performance requirements	127
F.2.4 Requirements for support of RRM	127
F.3 Interpretation of measurement results.....	127
F.4 Derivation of Test Requirements (This subclause is informative)	127
F.5 Acceptable uncertainty of Test Equipment (This subclause is informative)	131
F.5.1 Transmitter measurements.....	131
F.5.2 Receiver measurements	131
F.5.3 Performance measurements	132
F.6 General rules for statistical testing.....	132
Annex G (normative): Environmental conditions	133
G.1 General.....	133
G.2 Environmental requirements	133
G.2.1 Temperature	133
G.2.2 Voltage.....	133
G.2.3 Vibration.....	134
Annex H (normative): Terminal Baseline and Service Implementation Capabilities (TDD)	135
H.1 Baseline Implementation Capabilities:	135
H.2 Service Implementation Capabilities:	135
Annex I (informative): Change history	136
Foreword.....	9
1— Scope.....	10
2— References.....	10
3— Definitions, abbreviations and equations.....	10
3.1 Definitions	10
3.2 Abbreviations	11
3.3 Equations.....	11
4— Frequency bands and channel arrangement	11
4.1 General	11
4.2 Frequency bands.....	11
4.3 TX-RX frequency separation.....	12

4.4	Channel arrangement	12
4.4.1	Channel spacing	12
4.4.2	Channel raster	12
4.4.3	Channel number	12
5	Transmitter Characteristics	12
5.1	General	12
5.2	User Equipment maximum output power	13
5.2.1	Definition and applicability	13
5.2.2	Minimum Requirements	13
5.2.3	Test purpose	13
5.2.4	Method of test	14
5.2.4.1	Initial conditions	14
5.2.4.2	Procedure	14
5.2.5	Test Requirements	14
5.3	UE frequency stability	15
5.3.1	Definition and applicability	15
5.3.2	Minimum Requirements	15
5.3.3	Test purpose	15
5.3.4	Method of test	15
5.3.4.1	Initial conditions	15
5.3.4.2	Procedure	16
5.3.5	Test Requirements	16
5.4	Output Power Dynamics	16
5.4.1	Uplink power control	16
5.4.1.1	Initial accuracy	16
5.4.1.1.1	Definition and applicability	16
5.4.1.1.2	Conformance requirements	16
5.4.1.1.3	Test purpose	17
5.4.1.1.4	Method of test	17
5.4.1.1.4.1	Initial conditions	17
5.4.1.1.4.2	Procedure 17	
5.4.1.1.5	Test requirements	17
5.4.1.2	Differential accuracy, controlled input	17
5.4.1.2.1	Definition and applicability	17
5.4.1.2.2	Conformance requirements	18
5.4.1.2.3	Test purpose	18
5.4.1.2.3	Method of test	18
5.4.1.2.3.1	Initial conditions	18
5.4.1.2.3.2	Procedure 18	
5.4.1.2.4	Test requirements	19
5.4.2	Minimum transmit output power	19
5.4.2.1	Definition and applicability	19
5.4.2.2	Minimum Requirements	19
5.4.2.3	Test purpose	19
5.4.2.4	Method of test	19
5.4.2.4.1	Initial conditions	19
5.4.2.4.2	Procedure	19
5.4.2.5	Test requirements	20
5.4.3	Transmit OFF power	20
5.4.3.1	Definition and applicability	20
5.4.3.2	Minimum Requirements	20
5.4.3.3	Test purpose	20
5.4.3.4	Method of test	20
5.4.3.5	Test requirements	20
5.4.4	Transmit ON/OFF Time mask	20
5.4.4.1	Definition and applicability	20
5.4.4.2	Conformance requirements	21
5.4.4.3	Test Purpose	21
5.4.4.4	Method of test	21
5.4.4.4.1	Initial conditions	21
5.4.4.4.2	Procedure	21

5.4.4.5	Test requirements	22
5.4.5	Out of synchronisation handling of output power	22
5.4.5.1	Definition and applicability	22
5.4.5.2	Minimum Requirement	22
5.4.5.3	Test purpose	23
5.4.5.4	Method of test	23
5.4.5.4.1	Initial conditions	23
5.4.5.4.2	Procedure	24
5.4.5.5	Test Requirements	24
5.5	Output RF spectrum emissions	24
5.5.1	Occupied bandwidth	24
5.5.1.1	Definition and applicability	24
5.5.1.2	Minimum Requirements	24
5.5.1.3	Test purpose	25
5.5.1.4	Method of test	25
5.5.1.4.1	Initial conditions	25
5.5.1.4.2	Procedure	25
5.5.1.5	Test requirements	25
5.5.2	Out of band emission	25
5.5.2.1	Spectrum emission mask	25
5.5.2.1.1	Definition and applicability	25
5.5.2.1.2	Minimum Requirements	26
5.5.2.1.3	Test purpose	26
5.5.2.1.4	Method of test	26
5.5.2.1.5	Test requirements	27
5.5.2.2	Adjacent Channel Leakage power Ratio (ACLR)	27
5.5.2.2.1	Definition and applicability	27
5.5.2.2.2	Minimum Requirements	27
5.5.2.2.3	Test purpose	27
5.5.2.2.4	Method of test	28
5.5.2.2.5	Test requirements	28
5.5.3	Spurious emissions	28
5.5.3.1	Definition and applicability	28
5.5.3.2	Minimum Requirements	29
5.5.3.3	Test purpose	29
5.5.3.4	Method of test	29
5.5.3.4.1	Initial conditions	29
5.5.3.4.2	Procedure	29
5.5.3.5	Test requirements	30
5.6	Transmit Intermodulation	30
5.6.1	Definition and applicability	30
5.6.2	Minimum Requirements	30
5.6.3	Test purpose	31
5.6.4	Method of test	31
5.6.4.1	Initial conditions	31
5.6.4.2	Procedure	31
5.6.5	Test requirements	31
5.7	Transmit Modulation	32
5.7.1	Error Vector Magnitude	32
5.7.1.1	Definition and applicability	32
5.7.1.2	Minimum Requirements	32
5.7.1.3	Test purpose	32
5.7.1.4	Method of test	32
5.7.1.4.1	Initial conditions	32
5.7.1.4.2	Procedure	32
5.7.1.5	Test requirements	32
5.7.2	Peak code domain error	33
5.7.2.1	Definition and applicability	33
5.7.2.2	Minimum Requirement	33
5.7.2.3	Test purpose	33
5.7.2.4	Method of test	33
5.7.2.4.1	Initial conditions	33

5.7.2.4.2	Procedure	33
5.7.2.5	Test requirements	33
6	Receiver Characteristics	34
6.1	General	34
6.2	Reference sensitivity level	34
6.2.1	Definition and applicability	34
6.2.2	Minimum Requirements	34
6.2.3	Test purpose	34
6.2.4	Method of test	35
6.2.4.1	Initial conditions	35
6.2.4.2	Procedure	35
6.2.5	Test requirements	35
6.3	Maximum Input Level	35
6.3.1	Definition and applicability	35
6.3.2	Conformance requirements	35
6.3.3	Test purpose	36
6.3.4	Method of test	36
6.3.4.1	Initial conditions	36
6.3.4.2	Procedure	36
6.3.5	Test requirements	36
6.4	Adjacent Channel Selectivity (ACS)	36
6.4.1	Definition and applicability	36
6.4.2	Minimum Requirements	36
6.4.3	Test purpose	37
6.4.4	Method of test	37
6.4.4.1	Initial conditions	37
6.4.4.2	Procedure	37
6.4.5	Test Requirements	37
6.5	Blocking Characteristics	37
6.5.1	Definition and applicability	37
6.5.2	Minimum Requirements	38
6.5.3	Test purpose	39
6.5.4	Method of test	39
6.5.4.1	Initial conditions	39
6.5.4.2	Procedure	39
6.5.5	Test requirements	39
6.6	Spurious Response	40
6.6.1	Definition and applicability	40
6.6.2	Minimum Requirements	40
6.6.3	Test purpose	40
6.6.4	Method of test	40
6.6.4.1	Initial conditions	40
6.6.4.2	Procedure	41
6.6.5	Test requirements	41
6.7	Intermodulation Characteristics	41
6.7.1	Definition and applicability	41
6.7.2	Minimum Requirements	41
6.7.3	Test purpose	42
6.7.4	Method of test	42
6.7.4.1	Initial conditions	42
6.7.4.2	Procedure	42
6.7.5	Test requirements	42
6.8	Spurious Emissions	42
6.8.1	Definition and applicability	42
6.8.2	Minimum Requirements	42
6.8.3	Test purpose	43
6.8.4	Method of test	43
6.8.4.1	Initial conditions	43
6.8.4.2	Procedure	43
6.8.5	Test requirements	43

7	Performance Requirements	44
7.1	General	44
7.2	Demodulation in static propagation conditions	44
7.2.1	Demodulation of DCH	44
7.2.1.1	Definition and applicability	44
7.2.1.2	Conformance requirements	44
7.2.1.3	Test purpose	45
7.2.1.4	Method of test	45
7.2.1.4.1	Initial conditions	45
7.2.1.4.2	Procedure	45
7.2.1.5	Test requirements	45
7.3	Demodulation of DCH in multipath fading conditions	45
7.3.1	Multipath fading Case 1	45
7.3.1.1	Definition and applicability	45
7.3.1.2	Conformance requirements	46
7.3.1.3	Test purpose	46
7.3.1.4	Method of test	46
7.3.1.4.1	Initial conditions	46
7.3.1.4.2	Procedure	46
7.3.1.5	Test requirements	47
7.3.2	Multipath fading Case 2	47
7.3.2.1	Definition and applicability	47
7.3.2.2	Conformance requirement	47
7.3.2.3	Test purpose	47
7.3.2.4	Method of test	47
7.3.2.4.1	Initial conditions	47
7.3.2.4.2	Procedure	48
7.3.2.5	Test requirements	48
7.3.3	Multipath fading Case 3	48
7.3.3.1	Definition and applicability	48
7.3.3.2	Conformance requirements	48
7.3.3.3	Test purpose	49
7.3.3.4	Method of test	49
7.3.3.4.1	Initial conditions	49
7.3.3.4.2	Procedure	49
7.3.3.5	Test requirements	49
7.4	Base station transmit diversity mode	49
7.4.1	Demodulation of BCH in Block STTD mode	49
7.4.1.1	Conformance requirements	50
7.5	Power control in downlink	50
7.5.1	Conformance requirements	50
8	Requirements for Support of RRM	51
8.1	General	51
8.2	Idle Mode Tasks	51
8.2.1	Introduction	51
8.2.2	RF Cell Selection Scenario	51
8.2.2.1	Requirements for Cell Selection single carrier single cell case	51
8.2.2.2	Requirements for Cell Selection multicarrier carrier multi cell case	51
8.2.3	RF Cell Re-Selection Scenario	51
8.2.3.1	Requirements for Cell Re-Selection single carrier multi cell case	51
8.2.4	PLMN Selection and Re-Selection Scenario	51
8.2.5	Location Registration Scenario	51
8.3	RRC Connection mobility	51
8.3.1	Handover	51
8.3.1.1	Introduction	51
8.3.1.2	Handover 3G to 3G	51
8.3.1.2.1	TDD/TDD Handover	51
8.3.1.2.2	TDD/FDD Handover	52
8.3.1.3	Handover 3G to 2G	52
8.3.1.3.1	Handover to GSM	52
8.3.2	Radio Link Management	52

8.3.2.1	Link adaptation	52
8.3.3	Cell Update	52
8.3.4	URA Update	52
8.4	RRC Connection Control	52
8.4.1	Radio Access Bearer Control	52
8.5	Dynamic Channel Allocation	52
8.6	Timing characteristics	52
8.6.1	Timing Advance (TA) Requirements	52
8.7	Measurements Performance Requirements	52
8.7.1	Measurements Performance for UE	52
Annex A (informative): Connection Diagrams		53
Annex B (normative): Global In-Channel TX Test		57
B.1	General	57
B.2	Definition of the process	57
B.2.1	Basic principle	57
B.2.2	Output signal of the TX under test	57
B.2.3	Reference signal	57
B.2.4	void	58
B.2.5	Classification of measurement results	58
B.2.6	Process definition to achieve results of type "deviation"	58
B.2.7	Process definition to achieve results of type "residual"	59
B.2.7.1	Error Vector Magnitude (EVM)	59
B.2.7.2	Peak Code Domain Error (PCDE)	59
B.3	Notes	60
Annex C (normative): Measurement channels		62
C.1	General	62
C.2	UL Reference measurement channels	62
C.2.1	UL reference measurement channel (12.2 kbps)	62
C.2.2	UL multi code reference measurement channel (12.2 kbps)	63
C.2.3	UL reference measurement channel (64 kbps)	64
C.2.4	UL reference measurement channel (144 kbps)	65
C.2.5	UL reference measurement channel (384 kbps)	66
C.3	DL Reference measurement channels	67
C.3.1	DL reference measurement channel (12.2 kbps)	67
C.3.2	DL reference measurement channel (64 kbps)	68
C.3.3	DL reference measurement channel (144 kbps)	69
C.3.4	DL reference measurement channel (384 kbps)	70
C.3.5	BCH reference measurement channel	71
Annex D (normative): Propagation conditions		72
D.1	Test Environments	72
D.2	Propagation Conditions	72
D.2.1	Static propagation condition	72
D.2.2	Multi path fading propagation conditions	72
Annex E (normative): Common RF test conditions		73
E.1	General	73
E.2	Connection Set up	73
E.3	During connection	73
E.3.1	Measurement of Tx Characteristics	73
E.3.2	Measurement of Rx Characteristics	74
E.3.3	Measurement of Performance requirements	74

Annex F (normative):	General test conditions and declarations	75
F.1	Acceptable uncertainty of Test System	75
F.1.1	Measurement of test environments	75
F.1.2	Measurement of transmitter	76
F.1.3	Measurement of receiver	77
F.1.4	Performance requirement	77
F.1.5	Requirements for support of RRM	77
F.2	Test Tolerances (This subclause is informative)	77
F.2.1	Transmitter	78
F.2.2	Receiver	78
F.2.3	Performance requirements	78
F.2.4	Requirements for support of RRM	78
F.3	Interpretation of measurement results	79
F.4	Derivation of Test Requirements (This subclause is informative)	79
F.5	Acceptable uncertainty of Test Equipment (This subclause is informative)	83
F.5.1	Transmitter measurements	83
F.5.2	Receiver measurements	83
F.5.3	Performance measurements	84
F.6	General rules for statistical testing	84
Annex G (normative):	Environmental conditions	85
G.1	General	85
G.2	Environmental requirements	85
G.2.1	Temperature	85
G.2.2	Voltage	85
G.2.3	Vibration	86
Annex H (normative):	Terminal Baseline and Service Implementation Capabilities (TDD)	87
H.1	Baseline Implementation Capabilities:	87
H.2	Service Implementation Capabilities:	87
Annex I (informative):	Change history	88

Foreword

This Technical Specification (TS) has been produced by the 3rd Generation Partnership Project (3GPP).

The contents of the present document are subject to continuing work within the TSG and may change following formal TSG approval. Should the TSG modify the contents of the present document, it will be re-released by the TSG with an identifying change of release date and an increase in version number as follows:

Version x.y.z

where:

- x the first digit:
 - 1 presented to TSG for information;
 - 2 presented to TSG for approval;
 - 3 or greater indicates TSG approved document under change control.
- y the second digit is incremented for all changes of substance, i.e. technical enhancements, corrections, updates, etc.
- z the third digit is incremented when editorial only changes have been incorporated in the document.

1 Scope

This present document specifies the measurement procedure for the conformance test of the mobile station that contain transmitting characteristics, receiving characteristics and performance requirements and requirements for support of RRM (Radio Resource Management) in TDD mode of both options of the TDD mode of UTRA. The two options are the 3.84 Mcps TDD Option and 1.28 Mcps TDD Option, respectively. The requirements are listed in different subsections only if the corresponding parameters deviate.-

2 References

The following documents contain provisions which, through reference in this text, constitute provisions of the present document.

- References are either specific (identified by date of publication, edition number, version number, etc.) or non-specific.
- For a specific reference, subsequent revisions do not apply.
- For a non-specific reference, subsequent revisions do apply.

[1] 3GPP TS 25.102: "UE Radio transmission and reception (TDD)".

Note: The current version reflects 3G TS 25.102 version 3.2.04.0.0.
In addition CRs agreed on RAN4 level (Meeting #13, Turku, Finland, May 2000) are taken into account.

[2] 3GPP TS 25.123: "Requirements for Support of Radio Resource Management (TDD)".

[3] 3GPP TS 34.108 "Common Test Environments for User Equipment (UE) Conformance Testing"

[4] 3GPP TS 34.109: "Logical Test Interface; Special conformance testing functions".

[5] 3GPP TS 25.224: "Physical Layer Procedures (TDD)".

[6] 3GPP TR 21.905: "Vocabulary for 3GPP Specifications".

[7] 3GPP TR 25.990: "Vocabulary".

[8] ITU-R Recommendation SM.328-9: "Spectra and bandwidth of emissions".

[9] 3GPP TS 25.331: "Radio Resource Control (RRC) Protocol Specification".

3 Definitions, abbreviations and equations

Definitions, symbols, abbreviations and equations used in the present document are listed in TR 21.905 [6] and TR 25.990 [7].

3.1 Definitions

For the purpose of the present document, the following additional definitions apply:

Average power: [TBD]

3.2 Abbreviations

For the purpose of the present document, the following additional abbreviations apply.

AFC	Automatic Frequency Control
ATT	Attenuator
EVM	Error Vector Magnitude
FFS	For Further Study
HYB	Hybrid
OBW	Occupied Bandwidth
OCNS	Orthogonal Channel Noise Simulator, a mechanism used to simulate the users or control signals on the other orthogonal channels of a downlink.
PCDE	Peak Code Domain Error
PRBS	Pseudo Random Bit Sequence
SS	System Simulator
TBD	To Be Defined
TS	Time Slot
RRC	Root-Raised Cosine

3.3 Equations

For the purpose of the present document, the following additional equations apply.

I_{BTS}	Interference signal power level at BTS in dBm, which is broadcasted on BCH
I_{oac}	The power spectral density of the adjacent frequency channel as measured at the UE antenna connector.
$\frac{\sum \text{DPCH_Ec}}{I_{\text{or}}}$	The ratio of the sum of DPCH_Ec for one service in case of multicode to the total transmit power spectral density of the downlink at the BS antenna connector

4 Frequency bands and channel arrangement

4.1 General

The information presented in this section is based on [thea](#) chip rates of 3.84 Mcps [TDD Option and 1.28 Mcps TDD Option](#).

~~NOTE:—Other chip rates may be considered in future releases.~~

4.2 Frequency bands

UTRA/TDD is designed to operate in the following bands;

- a) 1900 – 1920 MHz: Uplink and downlink transmission
2010 – 2025 MHz: Uplink and downlink transmission
- b)* 1850 – 1910 MHz: Uplink and downlink transmission
1930 – 1990 MHz: Uplink and downlink transmission
- c)* 1910 – 1930 MHz: Uplink and downlink transmission

* Used in ITU Region 2.

Additional allocations in ITU region 2 are for further study.

Deployment in existing or other frequency bands is not precluded.

4.3 TX–RX frequency separation

4.3.1 3.84 Mcps TDD Option

No TX-RX frequency separation is required as Time Division Duplex (TDD) is employed. Each TDMA frame consists of 15 timeslots where each timeslot can be allocated to either transmit or receive.

4.3.2 1.28 Mcps TDD Option

No TX-RX frequency separation is required as Time Division Duplex (TDD) is employed. Each subframe consists of 7 main timeslots where all main timeslots (at least the first one) before the single switching point are allocated DL and all main timeslots (at least the last one) after the single switching point are allocated UL.

4.4 Channel arrangement

4.4.1 Channel spacing

4.4.1.1 3.84 Mcps TDD Option

The nominal channel spacing is 5 MHz, but this can be adjusted to optimise performance in a particular deployment scenario.

4.4.1.2 1.28 Mcps TDD Option

The nominal channel spacing is 1.6 MHz, but this can be adjusted to optimise performance in a particular deployment scenario.

4.4.2 Channel raster

The channel raster is 200 kHz, which means that the carrier frequency must be a multiple of 200 kHz.

4.4.3 Channel number

The carrier frequency is designated by the UTRA absolute radio frequency channel number (UARFCN). The value of the UARFCN in the IMT2000 band is defined as follows:

$$N_t = 5 * F \quad 0.0 \text{ MHz} \leq F \leq 3276.6 \text{ MHz} \quad \text{where } F \text{ is the carrier frequency in MHz}$$

5 Transmitter Characteristics

5.1 General

Transmitting performance test of the UE is implemented during communicating with the SS via air interface. The procedure is uses normal call protocol until the UE is communicating on traffic channel basically. (Refer to TS 34.108 [3] Common Test Environments for User Equipment (UE) Conformance Testing) On the traffic channel, the UE provides special function for testing that is called Logical Test Interface and the UE is tested using this function. (Refer to TS 34.109 [4] Logical Test Interface; Special conformance testing functions).

Unless detailed the transmitter characteristic are specified at the antenna connector of the UE. For UE with integral antenna only, a reference antenna with a gain of 0 dBi is assumed. Transmitter characteristics for UE(s) with multiple antennas/antenna connectors are for further study.

The UE antenna performance has a significant impact on system performance, and minimum requirements on the antenna efficiency are therefore intended to be included in future versions of this specification. It is recognized that different requirements and test methods are likely to be required for the different types of UE.

The common RF test conditions are defined in annex E, and each test conditions in this Chapter should refer annex E. Individual test conditions are defined in the paragraph of each test.

5.2 User Equipment maximum output power

5.2.1 Definition and applicability

The maximum output power and its tolerance are defined according to the Power Class of the UE.

The **output power**, P_{out} , of the UE is the power when averaged (in the sense of thermal power) over the useful part of the TS at the maximum power control setting delivered in to a load with resistance equal to the nominal load impedance.

The requirements in this test apply to all UTRA – TDD- UEs

Notes copied from TS 25.102 clause 6.2.1 :

1. The maximum output power refers to the measure of power when averaged over the useful part of the transmit timeslots at the maximum power control setting.
2. For multi-code operation the maximum output power will be reduced by the difference of peak to average ratio between single and multi-code transmission.
3. The tolerance of the maximum power is below the prescribed value even at the multi-code transmission mode
4. For UE using directive antennas for transmission, a class dependent limit will be placed on the maximum EIRP (Equivalent Isotropic Radiated Power).

5.2.2 Minimum Requirements

The error of the UE maximum output power shall not exceed the tolerance shown in Tables 5.2.2 a and b for single and multi-code.

Table 5.2.2.a: Maximum Output Power single code

Power Class	Maximum output power	Tolerance
1	+30 dBm	+1dB/-3dB
2	+24 dBm	+1dB /-3dB
3	+21 dBm	+2dB /-2dB
4	+10 dBm	+4dB/-4dB

Table 5.2.2.b: Maximum Output Power multi code

Power Class	Maximum output power	Tolerance
1	[+27 ¹⁾]dBm	+1dB/-3dB
2	[21 ¹⁾] dBm	+1dB /-3dB
3	[18 ¹⁾] dBm	+2dB /-2dB
4	[+7 ¹⁾] dBm	+4dB/-4dB

Note 1: These figures are not mentioned in 25.102. Instead there is a note, saying:
 “For multi-code operation the maximum output power will be reduced by the difference of peak to average ratio between single and multi-code transmission.”

The figures are calculated from maximum output power single code (table 5.2.2.a) and UL multicode reference measurement channel (12.2 kbit/s) (annex C.2.2.1 [for the 3.84 TDD Option](#) and annex C.2.2.2 [for the 1.28 Mcps TDD Option, respectively](#)) containing two code signals with equal level.

The normative reference for this requirement is 25.102 [\[1\]](#) clause 6.2.1.

5.2.3 Test purpose

For the following reasons:

Limit interference.

Verify that the maximum output power is achievable.

It is the purpose of the test to verify that the UE's maximum output power is within its tolerance limits under all environmental conditions.

5.2.4 Method of test

5.2.4.1 Initial conditions

- 1) Connect the SS to the UE antenna connector as shown in Figure A.1.
- 2) Calls are set up according to the Generic call setup procedure using parameters as specified in Tables 5.2.4.1.1a and b [for the 3.84 Mcps TDD Option and in Tables 5.2.4.1.2a and b for the 3.84 Mcps TDD Option, respectively.](#)
- 3) Enter the UE into loopback test mode and start the loopback test.

5.2.4.1.1 [3.84 Mcps TDD Option](#)

Table 5.2.4.1.1.a: Test parameters for Maximum Output Power single code [\(3.84 Mcps TDD Option\)](#)

Parameter	Value/description
UL Reference measurement channel	12.2kbps, according to annex C.2.1.1
Uplink Power Control	SS level and signalling values such that UE transmits maximum power.
Data content	Real life (sufficient irregular)

Table 5.2.4.1.1b: Test parameters for Maximum Output Power multicode [\(3.84 Mcps TDD Option\)](#)

Parameter	Value/description
Reference measurement channel	Multicode 12.2kbps, according to annex C.2.2.1
Uplink Power Control	SS level and signalling values such that UE transmits maximum power
Data content	real life (sufficient irregular)

5.2.4.1.2 1.28 Mcps TDD Option

Table 5.2.4.1.2.a: Test parameters for Maximum Output Power single code (1.28 Mcps TDD Option)

Parameter	Value/description
UL Reference measurement channel	12.2kbps, according to annex C.2.1.2.
Uplink Power Control	SS level and signalling values such that UE transmits maximum power.
Data content	real life (sufficient irregular)

Table 5.2.4.1.2.b: Test parameters for Maximum Output Power multicode (1.28 Mcps TDD Option)

Parameter	Value/description
Reference measurement channel	Multicode 12.2kbps, according to annex C.2.2.2.
Uplink Power Control	SS level and signalling values such that UE transmits maximum power.
Data content	real life (sufficient irregular)

5.2.4.2 Procedure

- 1) Measure thermal power over the useful part of the burst.

with a measurement bandwidth of at least 5 MHz related to 3.84 Mcps TDD Option and with a measurement bandwidth of at least 1.6 MHz in case of 1.28 Mcps TDD Option.

- 2) Average over TBD time slots.
- 3) Run step 1) and 2) for RF channels Low / Mid / High

5.2.5 Test Requirements

The output power, measured in step 2) of subclause 5.2.4.2, shall not exceed the prescribed tolerance in Table 5.2.5 a and b.

Table 5.2.5.a: Maximum Output Power single code

Power Class	Maximum output power	Tolerance
1	+30 dBm	[+1.7] dB / [-3.7] dB
2	+24 dBm	+1.7dB /-3.7dB
3	+21 dBm	+2.7dB /-2.7dB
4	+10 dBm	[+4.7] dB / [-4.7] dB

Table 5.2.5.b: Maximum Output Power multi code

Power Class	Maximum output power	Tolerance
1		
2	[21] dBm	+1.7dB /-3.7dB
3	[18] dBm	+2.7dB /-2.7dB
4		

NOTE: If the above Test Requirement differs from the Minimum Requirement then the Test Tolerance applied for this test is non-zero. The Test Tolerance for this test is defined in Annex F.2 and the explanation of how the Minimum Requirement has been relaxed by the Test Tolerance is given in Annex F.4.

Note: [Concerning multicode transmission this test applies only for UE power classes 2 and 3. It is intended, that additional test requirements for UE power classes 1 and 4 in this case are part of a later \[version of this specification\]\(#\).](#)

5.3 UE frequency stability

5.3.1 Definition and applicability

The frequency stability is the difference of the modulated carrier frequency between the RF transmission from the UE and the RF transmission from the BS. The UE shall use the same frequency source for both RF frequency generation and chip clocking.

The requirements of this test apply to all types of UTRA- UE.

5.3.2 Minimum Requirements

The UE frequency stability, observed over a period of one timeslot, shall be within ± 0.1 ppm compared to signals received from the BS.

The normative reference for this requirement is [1] TS 25.102 subclause 6.3.

5.3.3 Test purpose

Reliable frequency stability of the UE's transmitter in certain tolerance limits is prerequisite for connectivity.

This test stresses the ability of the UE's receiver to derive correct frequency information from the received signal for the transmitter.

5.3.4 Method of test

5.3.4.1 Initial conditions

[5.3.4.1.1 3.84 Mcps TDD Option](#)

- 1) Connect the SS to the UE antenna connector as shown in Figure A.1.
- 2) A call is set up according to the Generic call setup procedure using parameters as specified in table 5.3.4.1.
- 3) Enter the UE into loopback test mode and start the loopback test.

Table 5.3.4.1.1: Test parameters for Frequency Stability ([3.84 Mcps TDD Option](#))

Parameter	Value/description
SS level (lor)	-105 dBm / 3.84MHz (reference sensitivity)
UL reference measurement channel	12.2kbps according to annex C.2.1.1 .
Data content	real life (sufficient irregular)

5.3.4.1.2 1.28 Mcps TDD Option

- 1) Connect the SS to the UE antenna connector as shown in Figure A.1.
- 2) A call is set up according to the Generic call setup procedure using parameters as specified in table 5.3.4.1.2.
- 3) Enter the UE into loopback test mode and start the loopback test.

Table 5.3.4.1.2: Test parameters for Frequency Stability (1.28 Mcps TDD Option)

<u>Parameter</u>	<u>Value/description</u>
<u>SS level (lor)</u>	<u>-108 dBm / 1.28MHz</u> <u>(reference sensitivity)</u>
<u>UL reference measurement channel</u>	<u>12.2kbps according to</u> <u>annex C.2.1.2</u>
<u>Data content</u>	<u>real life (sufficient irregular)</u>

5.3.4.2 Procedure

- 1) Measure the frequency error delta f across the TS according to annex B.
- 2) Repeat step 1) for 200 bursts (time slots).
- 3) Run Step 1) and 2) for RF channels Low /Mid/ High.

5.3.5 Test Requirements

For all measured bursts (time slots) , the frequency error, derived in subclause 5.3.4.2, shall not exceed $\pm (0.1 \text{ ppm} + 10\text{Hz})$.

NOTE: If the above Test Requirement differs from the Minimum Requirement then the Test Tolerance applied for this test is non-zero. The Test Tolerance for this test is defined in Annex F.2 and the explanation of how the Minimum Requirement has been relaxed by the Test Tolerance is given in Annex F.4

5.4 Output Power Dynamics

Power control is used to limit the interference level.

5.4.1 Uplink power control

Uplink power control is the ability of the UE transmitter to sets its output power in accordance with measured downlink path loss, values determined by higher layer signalling and path loss weighting parameter α as defined in TS 25.331 [9]. The output power is defined as the average power of the transmit timeslot, and is measured with a filter that has a Root-Raised Cosine (RRC) filter response with a roll off $\alpha = 0.22$ and a bandwidth equal to the chip rate.

5.4.1.1 Initial accuracy [\(3.84 Mcps TDD Option\)](#)

5.4.1.1.1 Definition and applicability

Initial Uplink power control is the ability of the UE transmitter to sets its output power in accordance with measured downlink path loss, and signalling values: I_{BTS} and Constant value, received from the BCH and applicable for the PRACH

The requirements and this test apply to all types of UTRA - UEs.

5.4.1.1.2 ~~Conformance~~ Minimum requirements

The UE power control, initial accuracy, is given in Table 5.4.1.1.2.

Table 5.4.1.1.2: Initial uplink power control tolerance [\(3.84 Mcps TDD Option\)](#)

Normal conditions	± 9 dB
Extreme conditions	± 12 dB

The reference for this requirement is [1] TS 25.102 clause 6.4.1.1.1.

5.4.1.1.3 Test purpose

The power of the received signal at the UE and the BCCH information control the power of the transmitted UE signal with the target to transmit at lowest power, acceptable for proper communication.

The test stresses the ability of the receiver to measure the received power over the receiver dynamic range and to derive from this correct transmitter-power

5.4.1.1.4 Method of test

5.4.1.1.4.1 Initial conditions

Connect the SS to the MS antenna connector as shown in Figure A.1.

A call is set up according to the generic call setup procedure [3] using parameters as specified in Table 5.4.1.1.4. The RACH procedure within the call setup is used for the test.

Table 5.4.1.1.4: Test parameters for uplink Power Control [\(3.84 Mcps TDD Option\)](#)

	RX-Upper dynamic end	RX-middle	RX-Sensitivity level
SS transmit power	-25 dBm/3.84 MHz	-65 dBm/3.84 MHz	-105 dBm/3.84 MHz
Broadcasted transmit-power CCPCH	35 dBm	35 dBm	24 dBm
Simulated path loss = Broadcasted TX – SS TX Power	60 dB	100 dB	129 dB
I_{BTS} (UL interference)	-75 dBm	-100 dBm	-110 dBm
Constant value	-10 dB	-10 dB	-10 dB
Nominal expected UE TX power	-25 dBm	-10 dBm	+9 dBm ²⁾

Note 1: While the SS transmit power shall cover the UE receiver input dynamic range, the logical parameters: broadcasted transmit power, I_{BTS} , and RACH constant value are chosen to achieve a UE TX power, located within the TX output power dynamic range of a class 3 UE.

Note 2: Nominal TX output power 9 dBm allows to check the uplink power control algorithm within the entire tolerance range (9 dBm \pm 12 dB: 9 dBm + 12 dB = 21 dBm = max power class 3).

5.4.1.1.4.2 Procedure

- 1) Set the SS transmit power according to table 5.4.1.1.4.
- 2) Measure the RACH output power of the UE according to Annex B.
- 3) Repeat the test for all SS transmit powers and parameters in table 5.4.1.1.4.

5.4.1.1.5 Test requirements

The deviation with respect to the nominal expected UE TX power (table 5.4.1.1.2.) , derived in step 2, shall not exceed the prescribed tolerance in Table 5.4.1.1.2.

5.4.1.2 Differential accuracy, controlled input [\(3.84 Mcps TDD Option\)](#)

5.4.1.2.1 Definition and applicability

Uplink power control, differential accuracy, is the ability of the UE transmitter to sets its output power in accordance with measured downlink path loss, and the signalling values: I_{BTS} , SIR_{Target} , Constant Value, received from higher layers and applicable for the DPCH.

Specifically, the uplink power control, differential accuracy, controlled input, is defined as the error in the UE transmitter power step as a result of a step in SIR_{TARGET} when the path loss weighting parameter $\alpha=0$, α calculated in the UE.

The requirements of this test apply to all types of UTRA -UE.

5.4.1.2.2 ~~Conformance~~ Minimum requirements

The step in SIR_{TARGET} shall be rounded to the closest integer dB value. The error shall not exceed the values in table 5.4.1.2.2.

Table 5.4.1.2.2.: Transmitter power step tolerance as a result of control power step
[\(3.84 Mcps TDD Option\)](#)

ΔSIR_{TARGET} [dB]	Transmitter power step tolerance [dB]
$\Delta SIR_{TARGET} \leq 1$	± 0.5
$1 < \Delta SIR_{TARGET} \leq 2$	± 1
$2 < \Delta SIR_{TARGET} \leq 3$	± 1.5
$3 < \Delta SIR_{TARGET} \leq 10$	± 2
$10 < \Delta SIR_{TARGET} \leq 20$	± 4
$20 < \Delta SIR_{TARGET} \leq 30$	± 6
$30 < \Delta SIR_{TARGET}$	± 9 ⁽¹⁾

(1) Value is given for normal conditions. For extreme conditions value is ± 12

The reference for this requirement is [1] TS 25.102 clause 6.4.1.[1.2](#).

5.4.1.2.3 Test purpose

It is verified if the UE sets correct uplink power steps in response to steps in the signalling value SIR_{Target} , signalled via the downlink to the UE

under the following conditions: keeping the other signalling parameters constant and deactivating any influence due to varying pathloss.

5.4.1.2.4.3 Method of test

5.4.1.2.4.3.1 Initial conditions

- 1) Connect the SS to the MS antenna connector as shown in Figure A.1.
- 2) A call is set up according to the generic call setup procedure using parameters as specified in Table 5.4.1.2.4

Table 5.4.1.2.4. Test parameters for Uplink Power Control, Differential Accuracy, Controlled Input (3.84 Mcps TDD Option)

Parameter	Value/description
UL reference measurement channel	12.2kbps according to annex C.2.1.1
BS Transmit to UE Transmit delay	7 TSS--> $\alpha=0$
SSTransmit power	[-65 dBm]
Reference transmit power broadcast on BCH	[35 dBm]
I _{BTS}	[-100]
Constant value	[-10]
Data content	real life (sufficient irregular)

5.4.1.2.4.2 Procedure

Using the SIR_{Target} -value in the downlink,

cover the UE-transmitter dynamic range by commanding the UEs power with the signalling value SIR_{Target} in a step resolution (positive and negative direction) of

- | | |
|------------------|---------------------------------------|
| 1 dB | approx. 68 steps up and 68 steps down |
| 2 dB | approx. 34 steps up and 34 steps down |
| 3 dB | approx. 22 steps up and 22 steps down |
| 10 dB | approx. 7 steps up and 7 steps down |
| 20 dB | approx. 3 steps up and 3 steps down |
| 30 dB | approx. 2 step up and 2 step down |
| maximum stepsize | 1 step up and 1 step down |

Measure the power according to Annex B.

5.4.1.2.5 Test requirements

For the UE output power laying between

Max Power minus tolerance and Min Power

the step response shall not exceed the prescribed tolerance in Table 5.4.1.2.2.

5.4.1.3 Open loop power control (1.28 Mcps TDD Option)

5.4.1.3.1 Definition and applicability

Open loop power control is the ability of the UE transmitter to sets its output power to a specific value. The open loop power control tolerance is given in Table 5.4.1.3.2.

5.4.1.3.2 Minimum requirements

The UE open loop power is defined as the average power in a timeslot or ON power duration, whichever is available, and they are measured with a filter that has a Root-Raised Cosine (RRC) filter response with a roll off $\alpha = 0.22$ and a bandwidth equal to the chip rate of 1.28 Mcps. The open loop power control tolerance is given in table 5.4.1.3.2.

Table 5.4.1.3.2: Open loop power control tolerance (1.28 Mcps TDD Option)

<u>Normal conditions</u>	<u>± 9 dB</u>
<u>Extreme conditions</u>	<u>± 12 dB</u>

5.4.1.3.3 Test purpose

TBD

5.4.1.3.4 Method of test

TBD

5.4.1.3.4.1 Initial conditions

TBD

5.4.1.3.4.2 Procedure

TBD

5.4.1.3.5 Test requirements

TBD

5.4.1.4 Closed loop power control (1.28 Mcps TDD Option)

5.4.1.4.1 Definition and applicability

Closed loop power control in the Uplink is the ability of the UE transmitter to adjust its output power in accordance with one or more TPC commands received in the downlink.

The power control step is the change in the UE transmitter output power in response to a single TPC command, TPC cmd, arrived at the UE.

5.4.1.4.2 Minimum requirements

The UE transmitter shall have the capability of changing the output power with a step size of 1, 2 and 3 dB according to the value of Δ_{TPC} in the slot immediately after the TPC cmd can be arrived.

- (a) The transmitter output power step due to closed loop power control shall be within the range shown in Table 5.4.1.4.2a.
- (b) The transmitter average output power step due to closed loop power control shall be within the range shown in Table 5.4.1.4.2b. Here a TPC cmd group is a set of TPC cmd values derived from a corresponding sequence of TPC commands of the same duration.

The closed loop power is defined as the relative power differences between averaged power of original (reference) timeslot and averaged power of the target timeslot without transient duration. They are measured with a filter that has a Root-Raised Cosine (RRC) filter response with a roll off $\alpha = 0.22$ and a bandwidth equal to the chip rate.

Table 5.4.1.4.2a: Transmitter power control range

TPC cmd	Transmitter power control range					
	1 dB step size		2 dB step size		3 dB step size	
	Lower	Upper	Lower	Upper	Lower	Upper
Up	+0.5 dB	+1.5 dB	+1 dB	+3 dB	+1.5 dB	+4.5 dB
Down	-0.5 dB	-1.5 dB	-1 dB	-3 dB	-1.5 dB	-4.5 dB

Table 5.4.1.4.2b: Transmitter average power control range

TPC cmd group	Transmitter power control range after 10 equal TPC cmd groups					
	1 dB step size		2 dB step size		3 dB step size	
	Lower	Upper	Lower	Upper	Lower	Upper
Up	+8 dB	+12 dB	+16 dB	+24 dB	+24 dB	+36 dB
Down	-8 dB	-12 dB	-16 dB	-24 dB	-24 dB	-36 dB

5.4.1.4.3 Test purpose

The purpose of this test is

- to verify that the UE inner loop power control size and response is meet to the described value shown in subclause 5.4.1.4.2. and
- to verify that the TPC cmd is correctly derived from received TPC commands.

5.4.1.4.4 Method of test

5.4.1.4.4.1 Initial conditions

- 1) Connect the SS to the UE antenna connector as shown in Figure A.1.
- 2) A call is set up according to the Generic call setup procedure.
- 3) Enter the UE into loopback test mode and start the loopback test.

See TS 34.108 [3] and TS 34.109 [4] for details regarding generic call setup procedure and loopback test.

5.4.1.4.4.2 Procedure

- 1) Before proceeding with paragraph (2) (Step A) below, set the output power of the UE, measured at the UE antenna connector, to be in the range -10 ± 9 dBm. This may be achieved by setting the downlink signal (\hat{I}_{or}) to yield an appropriate open loop output power and/or by generating suitable downlink TPC commands from the SS.
- 2) Step A: Configure the uplink channel to set the TPC step size to 1 dB. When the Configuration is complete, transmit a sequence of TPC commands with the value 1 until the UE output power is above the maximum power threshold.
- 3) Step B: Transmit a sequence of 68^1 TPC commands with the value 0.
- 4) Step C: Transmit a sequence of 68^1 TPC commands with the value 1.

- 5) Step D: Reconfigure the uplink channel to set the TPC step size to 2dB. When the reconfiguration is complete, transmit a sequence of TPC commands with the value 1 until the UE output power is above the maximum power threshold. Transmit a sequence of 34¹ TPC commands with the value 0.
- 6) Step E: Transmit a sequence of 34¹ TPC commands with the value 1.
- 7) Step F: Reconfigure the uplink channel to set the TPC step size to 3 dB. When the reconfiguration is complete, transmit a sequence of TPC commands with the value 1 until the UE output power is above the maximum power threshold. Transmit a sequence of 22¹ TPC commands with the value 0.
- 8) Step G: Transmit a sequence of 22¹ TPC commands with the value 1.

¹ NOTE: These numbers of TPC commands are given as examples. The actual number of TPC commands transmitted in these steps shall be sufficient to ensure that the UE reaches the relevant maximum or minimum power threshold.

5.4.1.4.5 Test requirements

- a) During Step B, the difference in mean output power between adjacent slots shall be within the prescribed range given in Table 5.4.1.4.2a for a TPC cmd of - 1 and step size of 1 dB, until the output power reaches (Minimum power threshold + 0.5 dB).
- b) During Step B, the change in mean output power over 10 consecutive slots shall be within the prescribed range for a TPC cmd group of - 1, and step size of 1 dB as given in Table 5.4.1.4.2b, until the output power reaches (Minimum power threshold + 0,5 dB).
- c) During Step C, the difference in mean output power between adjacent slots shall be within the prescribed range given in Table 5.4.1.4.2a for a TPC cmd of + 1 and step size of 1 dB, until the output power reaches (Maximum power threshold - 0,5 dB).
- d) During Step C, the change in mean output power over 10 consecutive slots shall be within the prescribed range for a TPC cmd group of + 1, and step size of 1 dB as given in Table 5.4.1.4.2b, until the output power reaches (Maximum power threshold - 0,5 dB).
- e) During Step D, the difference in mean output power between adjacent slots shall be within the prescribed range given in Table 5.4.1.4.2a for a TPC cmd of - 1 and step size of 2 dB, until the output power reaches (Minimum power threshold + 1 dB).
- f) During Step D, the change in mean output power over 10 consecutive slots shall be within the prescribed range for a TPC cmd group of - 1, and step size of 2 dB as given in Table 5.4.1.4.2b, until the output power reaches (Minimum power threshold +1 dB).
- g) During Step E, the difference in mean output power between adjacent slots shall be within the prescribed range given in Table 5.4.1.4.2a for a TPC cmd of + 1 and step size of 2 dB, until the output power reaches (Maximum power threshold -1 dB).
- h) During Step E, the change in mean output power over 10 consecutive slots shall be within the prescribed range for a TPC cmd group of + 1, and step size of 2 dB as given in Table 5.4.1.4.2b, until the output power reaches (Maximum power threshold - 1 dB).
- i) During Step F, the difference in mean output power between adjacent slots shall be within the prescribed range given in Table 5.4.1.4.2a for a TPC cmd of - 1 and step size of 3 dB, until the output power reaches (Minimum power threshold + 1 dB).
- j) During Step F, the change in mean output power over 10 consecutive slots shall be within the prescribed range for a TPC cmd group of - 1, and step size of 3 dB as given in Table 5.4.1.4.2b, until the output power reaches (Minimum power threshold +1 dB).
- k) During Step G, the difference in mean output power between adjacent slots shall be within the prescribed range given in Table 5.4.1.4.2a for a TPC cmd of + 1 and step size of 3 dB, until the output power reaches (Maximum power threshold -1 dB).

- 1) During Step G, the change in mean output power over 10 consecutive slots shall be within the prescribed range for a TPC cmd group of + 1, and step size of 3 dB as given in Table 5.4.1.4.2b, until the output power reaches (Maximum power threshold – 1 dB).

5.4.2 Minimum transmit output power

5.4.2.1 Definition and applicability

The minimum controlled output power of the UE is when the power control setting is set to a minimum value. This is when the uplink power control indicates a minimum transmit output power is required.

The normative requirements of this test apply to all types of UTRA- UE.

5.4.2.2 Minimum Requirements

5.4.2.2.1 3.84Mcps TDD Option

The minimum transmit power shall be lower than or equal to -44 dBm measured with a filter that has a root-raised cosine (RRC) filter response with a roll-off-factor $\alpha = 0.22$ and a bandwidth equal to the chip rate.

The normative reference for this requirement is TS 25.102 [1] subclause 6.4.2.1.1.

5.4.2.2.2 1.28Mcps TDD Option

The minimum transmit power shall be better than -49 dBm measured with a filter that has a root-raised cosine (RRC) filter response with a roll-off-factor $\alpha = 0.22$ and a bandwidth equal to the chip rate.

The normative reference for this requirement is TS 25.102 [1] subclause 6.4.2.1.2.

5.4.2.3 Test purpose

The test purpose is to verify the ability of the UE to reduce its output power to a specified value.

5.4.2.4 Method of test

5.4.2.4.1 Initial conditions

- 1) Connect the SS to the UE antenna connector as shown in Figure A.1.
- 2) A call is set up according to the Generic call setup procedure using parameters as specified in table E.3.1.2
- 3) Enter the UE into loopback test mode and start the loopback test.

5.4.2.4.2 Procedure

- 1) Configure the UE transmitter to enable power control steps of size 1 dB.
- 2) Measure power of the UE output signal over the useful part of the active time slot according to annex B.

NOTE: Annex B returns the power in the decision points (displayed as reference power and power offset). This is equivalent to thermal power at the air-interface. Insofar 5.4.2.2.1 minimum output power for 3.84 Mcps TDD Option and 5.4.2.2.2 minimum output power for 1.28 Mcps TDD Option is consistent with 5.2 maximum output power.

- 3) Average over TBD time slots.
- 4) Configure the UE transmitter to enable power control steps of 2 dB and of 3 dB, respectively, and repeat steps 2) to 3).

5) Run step 2) to 3) for RF channels Low Mid and High.

5.4.2.5 Test requirements

[5.4.2.5.1](#) [3.84 Mcps TDD Option](#)

For all measurements, the minimum transmit power derived in step 3), 4) and 5) of 5.4.2.4.2 shall be below -43 dBm.

[5.4.2.5.1](#) [1.28 Mcps TDD Option](#)

For all measurements, the minimum transmit power derived in step 3), 4) and 5) of 5.4.2.4.2 shall be below $[-48]$ dBm.

NOTE: If the above Test Requirement differs from the Minimum Requirement then the Test Tolerance applied for this test is non-zero. The Test Tolerance for this test is defined in Annex F.2 and the explanation of how the Minimum Requirement has been relaxed by the Test Tolerance is given in Annex F.4.

5.4.3 Transmit OFF power

5.4.3.1 Definition and applicability

The transmit OFF power state is when the UE does not transmit. This parameter is defined as the maximum output transmit power within the channel bandwidth when the transmitter is OFF.

The requirements of this test apply to all types of UTRA-UE.

5.4.3.2 Minimum Requirements

The transmit OFF power shall be below -65 dBm.

The normative reference for this requirement is TS 25.102 subclause 6.5.1.

5.4.3.3 Test purpose

refer clause 5.4.4.3.

5.4.3.4 Method of test

refer clause 5.4.4.4

5.4.3.5 Test requirements

The transmit OFF power shall be below -63.5 dBm.

NOTE: If the above Test Requirement differs from the Minimum Requirement then the Test Tolerance applied for this test is non-zero. The Test Tolerance for this test is defined in Annex F.2 and the explanation of how the Minimum Requirement has been relaxed by the Test Tolerance is given in Annex F.4

5.4.4 Transmit ON/OFF Time mask

5.4.4.1 Definition and applicability

The transmit ON/OFF time mask defines the ramping time allowed for the UE between transmit OFF power and transmit ON power.

This test applies for all UTRA TTD UEs.

5.4.4.2 Minimum Conformance requirements

5.4.4.2.1 3.84Mcps TDD Option

The transmit power level versus time shall meet the mask specified in figure 5.4.4.2, where the transmission period refers to the burst without guard-period for a single transmission slot, and to the period from the beginning of the burst in the first transmission slot to the end of the burst without guard period in the last transmission timeslot for consecutive transmission slots.

The reference for this requirement is TS25.102 [1] subclause 6.5.2.1.1.

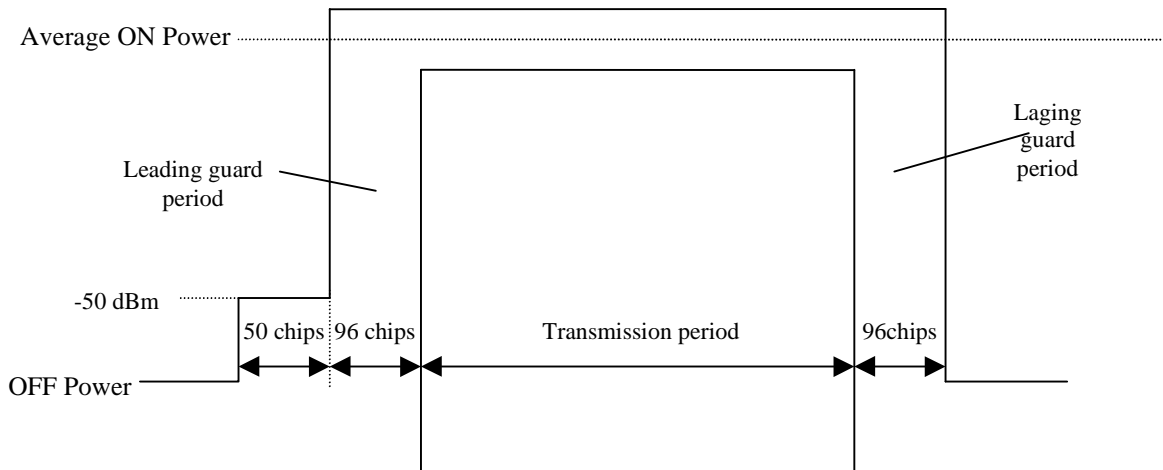

Figure 5.4.4.2.1: Transmit ON/OFF template for 3.84 Mcps TDD Option

5.4.4.2.2 1.28Mcps TDD Option

The transmit power level versus time shall meet the mask specified in figure 5.4.4.2.2, where the transmission period refers to the burst without guardperiod for a single transmission slot, and to the period from the beginning of the burst in the first transmission slot to the end of the burst without guard period in the last transmission timeslot for consecutive transmission slots.

The reference for this requirement is TS25.102 [1] subclause 6.5.2.1.2.

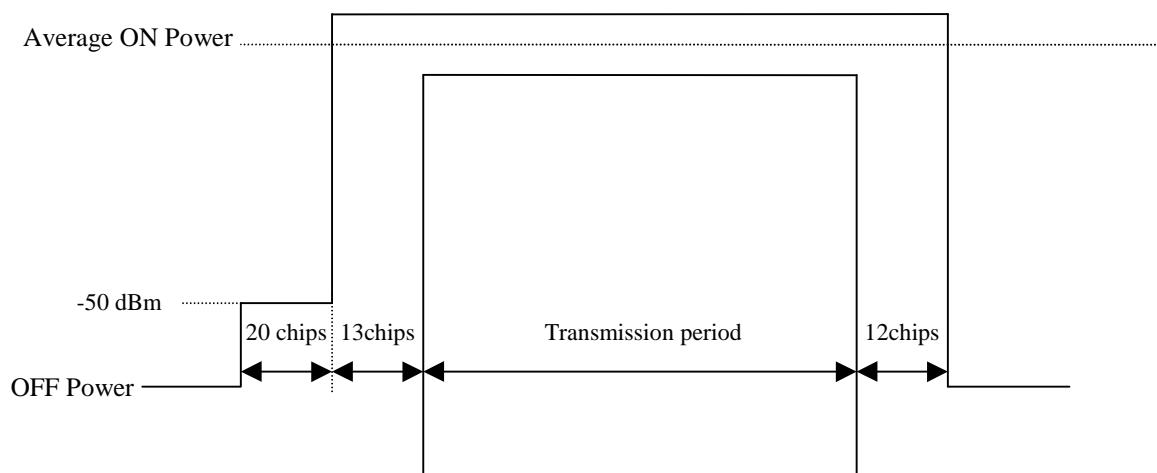

Figure 5.4.4.2.2: Transmit ON/OFF template for 1.28Mcps TDD Option

5.4.4.3 Test Purpose

It is tested if the UE TX signal uses the guard period for on-to-off and off-to-on transitions, where the time position of guard period is derived from the burst under test itself.

It is furtheron tested, if the UE TX signal is below certain limits outside transmission period and guard periods where the position in time is derived from the burst under test itself.

With this test interference to other UTRA TDD users are limited

Editor's note:

For the transmission period other tests apply.

For the absolute burst position in time other tests apply

5.4.4.4 Method of test

5.4.4.4.1 Initial conditions

Connect the SS to the UE antenna connector as shown in Figure A.1.

A call is set up according to the generic call setup procedure using parameters as specified in Table E.3.1.2.

Enter the UE into loopback test mode and start the loopback test.

5.4.4.4.2 Procedure

- 1) The time position of the midamble of the burst under test (TimeSlot s in Frame f) shall be the reference for the time position of the leading and laging guard-periods of the burst under test and, alternatively, for the equivalent guard periods of the next 2 bursts.
- 2) Record the following time periods with at least 2 samples /chip through a matched filter (RRC 0.22, BW equal to the chiprate) : TS $s-1$ and TS $s+1$ in frame f or $f+1$ or $f+2$
- 3) Calculate power samples by averaging the recorded samples of one chip duration.

5.4.4.5 Test requirements

Each power sample shall be below the limits (off Power (subclause 5.4.3.) and -50 dBm), indicated in figure 5.4.4.2. [1 for 3.84 Mcps TDD Option and figure 5.4.4.2.2 for 1.28 Mcps TDD Option, respectively.](#)

Editor's note: In this test no power limits apply during guard period.

5.4.5 Out-of-synchronisation handling of output power

5.4.5.1 Definition and applicability

The UE shall monitor the DPCH quality in order to detect a loss of the signal on Layer 1, as specified in TS 25.224. [5] The thresholds Q_{out} and Q_{in} specify at what DPCH quality levels the UE shall shut its power off and when it shall turn its power on, respectively. The thresholds are not defined explicitly, but are defined by the conditions under which the UE shall shut its transmitter off and turn it on, as stated in this clause.

The requirement of this subclause shall apply to all types of UTRA-UE.

5.4.5.2 Minimum Requirement

[5.4.5.2.1 3.84 Mcps TDD Option](#)

The parameters in Table 5.4.5.2.1 are defined using the DL reference measurement channel (12.2) kbps specified in Annex C where the CRC bits are replaced by data bits, and with static propagation conditions.

Table 5.4.5.2.14: DCH parameters for test of Out-of-synch handling

Parameter	Unit	Value
\hat{I}_{or}/I_{oc}	dB	-1
I_{oc}	dBm/3.84 MHz	-60
$\frac{\Sigma DPCH_E_c}{I_{or}}$	dB	See figure 5.4.5.2.14
Information Data Rate	kbps	13
TFCI	-	On

The conditions for when the UE shall shut its transmitter off and when it shall turn it on are defined by the parameters in Table 5.4.5.1.1 together with the DPCH power level as defined in Figure 5.4.5.1.

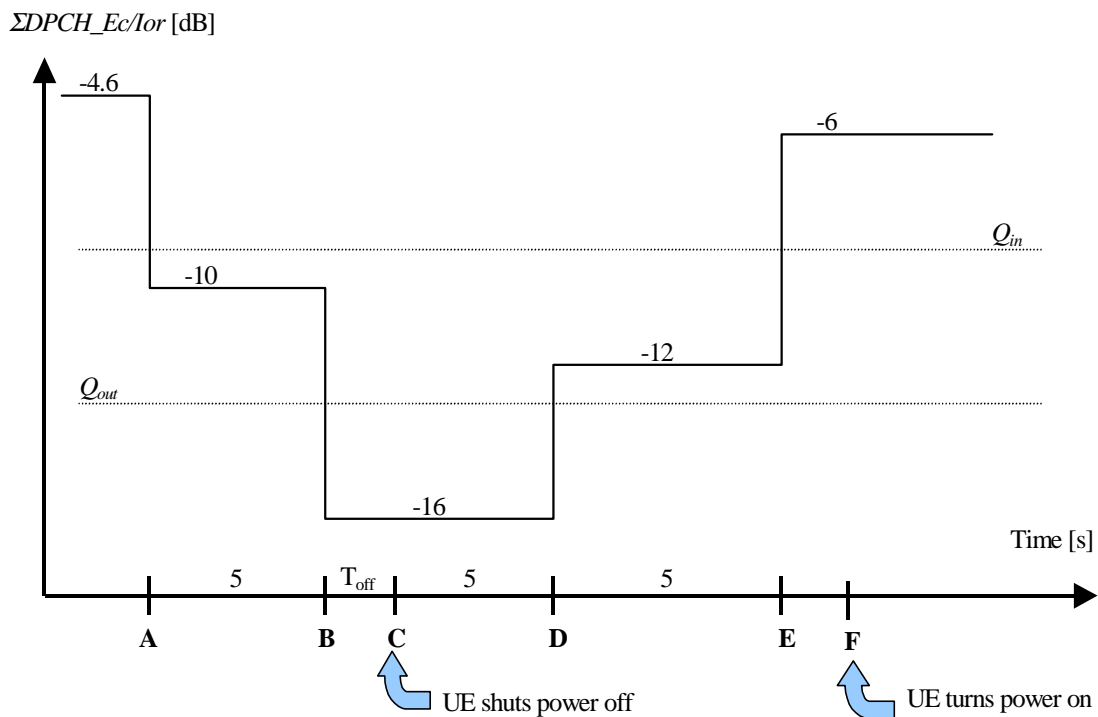

Figure 5.4.5.2.14. Conditions for out-of-synch handling in the UE. The indicated thresholds Q_{out} and Q_{in} are only informative. Conditions apply for 3.84 Mcps TDD Option.

The requirements for the UE are that:

- 1) The UE shall not shut its transmitter off before point B.
- 2) The UE shall shut its transmitter off before point C, which is $T_{off} = 200$ ms after point B
- 3) The UE shall not turn its transmitter on between points C and E.
- 4) The UE shall turn its transmitter on before point F, which is $T_{on} = 200$ ms after Point E.

The normative reference for this test is 25.102 [1] clause 6.4.3.1.1.

5.4.5.2.2 1.28 Mcps TDD Option

The parameters in Table 5.4.5.2.2 are defined using the DL reference measurement channel (12.2) kbps specified in Annex C where the CRC bits are replaced by data bits, and with static propagation conditions.

Table 5.4.5.2.2: DCH parameters for test of Out-of-synch handling

Parameter	Unit	Value
\hat{I}_{or}/I_{oc}	dB	-1
I_{oc}	dBm/1.28 MHz	-60
$\frac{\Sigma DPCH_E_c}{I_{or}}$	dB	See figure 5.4.5.2.2
Information Data Rate	kbps	12.2
TFCI	-	On

The conditions for when the UE shall shut its transmitter off and when it shall turn it on are defined by the parameters in Table 5.4.5.1.2 together with the DPCH power level as defined in Figure 5.4.5.1.

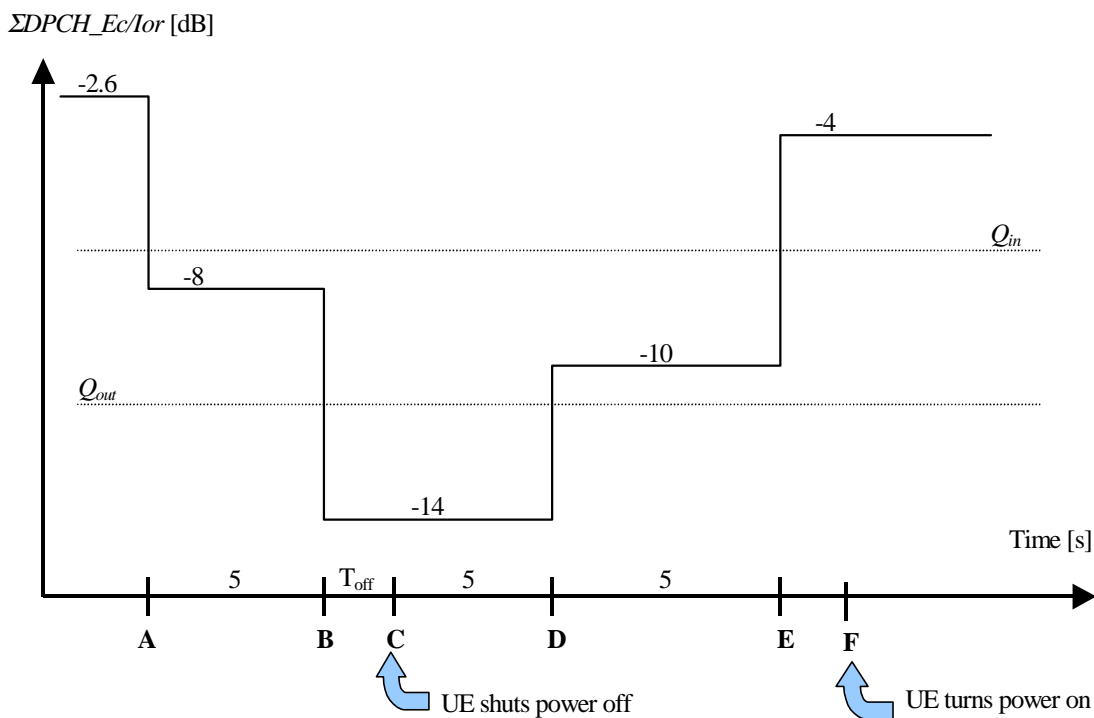

Figure 5.4.5.2.2: Conditions for out-of-synch handling in the UE. The indicated thresholds Q_{out} and Q_{in} are only informative. Conditions apply for 1.28 Mcps TDD Option.

The requirements for the UE are that:

1. The UE shall not shut its transmitter off before point B.
2. The UE shall shut its transmitter off before point C, which is $T_{off} = 200$ ms after point B
3. The UE shall not turn its transmitter on between points C and E.
4. The UE shall turn its transmitter on before point F, which is $T_{on} = 200$ ms after Point E.

The normative reference for this test is 25.102 [1] clause 6.4.3.1.2.

5.4.5.3 Test purpose

To verify that the UE monitors the DPCH quality and turns its transmitter on or off according to DPCH level diagram specified in figure 5.4.5.1

5.4.5.4 Method of test

5.4.5.4.1 Initial conditions

- 1) Connect the SS to the UE antenna connector as shown in Figure A.1.
- 2) Calls are set up according to the Generic call setup procedure using parameters as specified in table 5.4.5.1
- 3) Enter the UE into loopback test mode and start the loopback test.

5.4.5.4.2 Procedure

5.4.5.4.2.1 3.84 Mcps TDD Option

- 1) The SS sends continuously Up power control commands to the UE until the UE transmitter power reaches maximum level

- 2) Set the SS TX signal quality to $\frac{\Sigma DPCH_E_c}{I_{or}} = -4.6 + [0.3]$ dB and verify that the UE TX signal is on.

- 3) Set the SS TX signal quality to $\frac{\Sigma DPCH_E_c}{I_{or}} = -10 + [0.3]$ dB and verify that the UE TX signal remains on continuously for at least 5 seconds.

- 4) Set the SS TX signal quality to $\frac{\Sigma DPCH_E_c}{I_{or}} = -16 - [0.3]$ dB and verify that the UE TX signal turns off 200 ms or earlier with respect to that instant.

- 5) Set the SS TX signal quality to $\frac{\Sigma DPCH_E_c}{I_{or}} = -12 - [0.3]$ dB and verify that the UE TX signal remains off continuously for at least 5 seconds.

- 6) Set the SS TX signal quality to $\frac{\Sigma DPCH_E_c}{I_{or}} = -6 + [0.3]$ dB and verify that the UE TX signal is switched on 200 ms or earlier with respect to that instant.

5.4.5.4.2.2 1.28 Mcps TDD Option

- 1) The SS sends continuously Up power control commands to the UE until the UE transmitter power reaches maximum level

- 2) Set the SS TX signal quality to $\frac{\Sigma DPCH_E_c}{I_{or}} = -2.6 + [0.3]$ dB and verify that the UE TX signal is on.

- 3) Set the SS TX signal quality to $\frac{\Sigma DPCH_E_c}{I_{or}} = -8 + [0.3]$ dB and verify that the UE TX signal remains on continuously for at least 5 seconds.

- 4) Set the SS TX signal quality to $\frac{\Sigma DPCH_E_c}{I_{or}} = -14 - [0.3]$ dB and verify that the UE TX signal turns off 200 ms or earlier with respect to that instant.

5) Set the SS TX signal quality to $\frac{\Sigma DPCH - E_c}{I_{or}} = -10-[0.3]$ dB and verify that the UE TX signal remains off continuously for at least 5 seconds.

6) Set the SS TX signal quality to $\frac{\Sigma DPCH - E_c}{I_{or}} = -4+[0.3]$ dB and verify that the UE TX signal is switched on 200 ms or earlier with respect to that instant.

5.4.5.5 Test Requirements

The UE TX on-criterion including tolerance window is derived from the initial conditions and is verified with the method of 5.4.2.4 -minimum transmit power related to minimum requirements according to clause 5.4.2.2.1 for 3.84 Mcps TDD Option and 5.4.2.2.2 for 1.28 Mcps TDD Option, respectively. The UE transmitter is considered to be on if the UE transmitted power is higher than the minimum output power.

The UE TX off criterion including tolerance is verified according to clause 5.4.3 of this TS (Transmit off power).

To pass the test, steps 1 through 6 of the procedure must be fulfilled.

5.5 Output RF spectrum emissions

5.5.1 Occupied bandwidth

5.5.1.1 Definition and applicability

Occupied bandwidth is a measure of the bandwidth containing 99% of the total integrated power for transmitted spectrum and is centered on the assigned channel frequency.

The requirements in this subclause shall apply to all types of UTRA - UE.

5.5.1.2 Minimum Requirements

5.5.1.2.1 3.84Mcps TDD Option

The occupied bandwidth shall be less than 5 MHz based on a chip rate of 3,84 Mcps.

The normative reference for this requirement is TS 25.102 [1] subclause 6.6.1.1.

5.5.1.2.2 1.28Mcps TDD Option

The occupied channel bandwidth shall be less than 1.6 MHz based on a chip rate of 1.28 Mcps.

The normative reference for this requirement is TS 25.102 [1] subclause 6.6.1.2.

5.5.1.3 Test purpose

The occupied bandwidth, defined in the Radio Regulations of the International Telecommunication Union ITU, is a useful concept for specifying the spectral properties of a given emission in the simplest possible manner; see also ITU-R Recommendation SM.328-9 [8].

The test purpose is to verify that the emission of the UE is sufficiently concentrated in the bandwidth for the service to be provided and is, therefore, not likely to create interference to other users of the spectrum beyond undue limits.

5.5.1.4 Method of test

5.5.1.4.1 Initial conditions

- 1) Connect the SS to the UE antenna connector as shown in Figure A.1.
- 2) A call is set up according to the generic call setup procedure using parameters as specified in table E.3.1.2.
- 3) Enter the UE into loopback test mode and start the loopback test.

5.5.1.4.2 Procedure

- 1) Measure the power of the transmitted signal with a measurement filter of bandwidth [30 kHz]. The characteristic of the filter shall be approximately Gaussian (typical spectrum analyzer filter). The center frequency of the filter shall be stepped in contiguous 30 kHz steps from a minimum frequency, which shall be [7,5 – 0,015] MHz for the 3.84 Mcps TDD Option and [2,4 – 0,015] MHz for the 1.28 Mcps TDD Option, respectively, below the assigned channel frequency of the transmitted signal, up to a maximum frequency, which shall be [7,5 – 0,015] MHz for the 3.84 Mcps TDD Option and [2,4 – 0,015] MHz for the 1.28 Mcps TDD Option, respectively, above the assigned channel frequency of the transmitted signal. The step duration shall be sufficient slow to capture the active TS. The measured power shall be recorded for each step.
- 2) Determine the total transmitted power by accumulating the recorded power measurements results of all steps.
- 3) Sum up the power upward from the lower boundary of the measured frequency range in '(2)' and seek the limit frequency point by which this sum becomes 0.5 % of "Total Power" and save this point as "Lower Frequency".
- 4) Sum up the power downward from the upper boundary of the measured frequency range in '(2)' and seek the limit frequency point by which this sum becomes 0.5 % of "Total Power" and save this point as "Upper Frequency".
- 5) Calculate the difference ("Upper Frequency" – "Lower Frequency" = "Occupied Bandwidth") between two limit frequencies obtained in '(4)' and '(5)'.

5.5.1.5 Test requirements

5.5.1.5.1 3.84 Mcps TDD Option

The measured Occupied Bandwidth, derived in step 5), shall not exceed 5 MHz for the 3.84 Mcps TDD Option.

NOTE: If the above Test Requirement differs from the Minimum Requirement then the Test Tolerance applied for this test is non-zero. The Test Tolerance for this test is defined in Annex F.2 and the explanation of how the Minimum Requirement has been relaxed by the Test Tolerance is given in Annex F.4.

5.5.1.5.2 1.28 Mcps TDD Option

The measured Occupied Bandwidth, derived in step 5), shall not exceed [1.6] MHz for the 1.28 Mcps TDD Option.

NOTE: If the above Test Requirement differs from the Minimum Requirement then the Test Tolerance applied for this test is non-zero. The Test Tolerance for this test is defined in Annex F.2 and the explanation of how the Minimum Requirement has been relaxed by the Test Tolerance is given in Annex F.4.

5.5.2 Out of band emission

Out of band emissions are unwanted emissions immediately outside the nominal channel resulting from the modulation process and non-linearity in the transmitter but excluding spurious emissions. This out of band emission limit is specified in terms of a spectrum emission mask and adjacent channel power ratio.

5.5.2.1 Spectrum emission mask

5.5.2.1.1 Definition and applicability

5.5.2.1.1.1 3.84 Mcps TDD Option

The spectrum emission mask of the UE is a requirement that applies to frequencies which are between 2.5 and 12.5MHz to both sides of the carrier frequency. The out of channel emission is specified relative to the UE output power in a 3.84 MHz bandwidth.

The requirements of this test apply to all types of UTRA-UE.

5.5.2.1.1.2 1.28 Mcps TDD Option

The spectrum emission mask of the UE applies to frequencies, which are between 0.8 and 4.0MHz from a carrier frequency. The out of channel emission is specified relative to the UE output power measured in a 1.28 MHz bandwidth.

5.5.2.1.2 Minimum Requirements

5.5.2.1.2.1 3.84 Mcps TDD Option

The power of any UE emission shall not exceed the levels specified in table 5.5.2.1.2.1

The normative reference for this requirement is 3G TS 25.102 clause 6.6.2.1.1.1.

Table 5.5.2.1.2.1: Spectrum Emission Mask Requirement (3.84 Mcps TDD Option)

Frequency offset from carrier Δf	Minimum requirement	Measurement bandwidth
2.5 - 3.5 MHz	$-35 - 15 * (\Delta f - 2.5)$ dBc	30 kHz
3.5 - 7.5 MHz	$-35 - 1 * (\Delta f - 3.5)$ dBc	1 MHz
7.5 - 8.5 MHz	$-39 - 10 * (\Delta f - 7.5)$ dBc	1 MHz
8.5 - 12.5 MHz	-49 dBc	1 MHz

Note

1. The first and last measurement position with a 30 kHz filter is 2.515 MHz and 3.485 MHz.
2. The first and last measurement position with a 1 MHz filter is 4 MHz and 12 MHz.
3. The lower limit shall be $-50\text{dBm}/3.84\text{ MHz}$ or which ever is higher.

5.5.2.1.2.2 1.28 Mcps TDD Option

The power of any UE emission shall not exceed the levels specified in table 5.5.2.1.2.2

The normative reference for this requirement is 3G TS 25.102 clause 6.6.2.1.1.2.

Table 5.5.2.1.2.2: Spectrum Emission Mask Requirement (1.28Mcps TDD Option)

<u>Frequency offset from carrier Δf</u>	<u>Minimum requirement</u>	<u>Measurement bandwidth</u>
<u>0.8 MHz</u>	<u>-35 dBc</u>	<u>30 kHz</u>
<u>0.8-1.8 MHz</u>	<u>$-35 - 14 * (\Delta f - 0.8)$ dBc</u>	<u>30 kHz</u>
<u>1.8-2.4 MHz</u>	<u>$-49 - 25 * (\Delta f - 1.8)$ dBc</u>	<u>30 kHz</u>
<u>2.4 - 4.0MHz</u>	<u>-49 dBc</u>	<u>1MHz</u>

- NOTE:
- 1) The first and last measurement position with a 30 kHz filter is 0.815 MHz and 2.385 MHz
 - 2) The first and last measurement position with a 1 MHz filter is 2.9MHz and 3.5MHz
 - 3) The lower limit shall be -55dBm/1.28 MHz or which ever is the higher.

5.5.2.1.3 Test purpose

This test supplements Occupied Bandwidth (verifying the spectral concentration of the UE's emissions) and Adjacent Channel Leakage Ratio (simulating the perception of other UTRA receivers) in a system independent way. It is the purpose of this test to limit interferences to other systems (wideband or narrowband).

5.5.2.1.4 Method of test

5.5.2.1.4.1 Initial conditions

- 1) Connect the SS to the UE antenna connector as shown in Figure A.1.
- 2) A call is set up according to the generic call setup procedure using parameters as specified in table E.3.1.2.
- 3) Enter the UE into loopback test mode and start the loopback test.

5.5.2.1.4.2 Procedure

- 1) Measure the power of the transmitted signal with a measurement filter of bandwidths according to table 5.5.2.1.2. 1 for the 3.84 Mcps TDD Option and 5.5.2.1.2.2 for the 1.28 Mcps TDD Option, respectively. The characteristic of the filter shall be approximately Gaussian (typical spectrum analyzer filter). The center frequency of the filter shall be stepped in contiguous steps according to table 5.5.2.1.2. 1 for the 3.84 Mcps TDD Option and 5.5.2.1.2.2 for the 1.28 Mcps TDD Option, respectively. The step duration shall be sufficient slow to capture the active TS. The measured power shall be recorded for each step.
- 2) Measure the wanted output power according to annex B.
- 3) Display the results of 1) in dBc with respect to 2).

5.5.2.1.5 Test requirements

5.5.2.1.5.1 3.84 Mcps TDD Option

The result 5.5.2.1.4.2. step 3) shall fulfil the requirements of table 5.5.2.1.5.1.

Table 5.5.2.1.5.1: Spectrum Emission Mask Requirement (3.84 Mcps TDD Option)

Frequency offset from carrier ?f	Minimum requirement	Measurement bandwidth
2.5 - 3.5 MHz	-33.5 -15*($\Delta f - 2.5$) dBc	30 kHz
3.5 - 7.5 MHz	-33.5- 1*($\Delta f - 3.5$) dBc	1 MHz
7.5 - 8.5 MHz	-37.5 - 10*($\Delta f - 7.5$) dBc	1 MHz
8.5 - 12.5 MHz	-47.5 dBc	1 MHz

Note:

1. The first and last measurement position with a 30 kHz filter is 2.515 MHz and 3.485 MHz.
2. The first and last measurement position with a 1 MHz filter is 4 MHz and 12 MHz.
3. The lower limit shall be -48.5dBm/3.84 MHz or which ever is higher

NOTE: If the above Test Requirement differs from the Minimum Requirement then the Test Tolerance applied for this test is non-zero. The Test Tolerance for this test is defined in Annex F.2 and the explanation of how the Minimum Requirement has been relaxed by the Test Tolerance is given in Annex F.4.

5.5.2.1.5.2 1.28 Mcps TDD Option

The result 5.5.2.1.4.2, step 3) shall fulfil the requirements of table 5.5.2.1.5.2.

Table 5.5.2.1.5.2: Spectrum Emission Mask Requirement (1.28Mcps TDD Option)

<u>Frequency offset from carrier Δf</u>	<u>Minimum requirement</u>	<u>Measurement bandwidth</u>
<u>0.8 MHz</u>	<u>[-33.5] dBc</u>	<u>30 kHz</u>
<u>0.8-1.8 MHz</u>	<u>[-33.5] - 14*(Δf-0.8) dBc</u>	<u>30 kHz</u>
<u>1.8-2.4 MHz</u>	<u>[-47.5] - 25*(Δf-1.8)dBc</u>	<u>30 kHz</u>
<u>2.4 - 4.0MHz</u>	<u>[-47.5] dBc</u>	<u>1MHz</u>

Note:

- The first and last measurement position with a 30 kHz filter is 0.815 MHz and 2.385 MHz
- The first and last measurement position with a 1 MHz filter is 2.9MHz and 3.5MHz
- The lower limit shall be [- 53.5] dBm/1.28 MHz or which ever is the higher.

NOTE: If the above Test Requirement differs from the Minimum Requirement then the Test Tolerance applied for this test is non-zero. The Test Tolerance for this test is defined in Annex F.2 and the explanation of how the Minimum Requirement has been relaxed by the Test Tolerance is given in Annex F.4.

5.5.2.2 Adjacent Channel Leakage power Ratio (ACLR)

5.5.2.2.1 Definition and applicability

Adjacent Channel Leakage power Ratio (ACLR) is the ratio of the wanted power to the power in an adjacent channel. Both the wanted power and adjacent channel power are measured with a Root-Raised Cosine (RRC) filter with roll-off $\alpha = 0.22$ and a bandwidth equal to the chip rate.

The requirements in this subclause shall apply to all types of UTRA-UE.

5.5.2.2.2 Minimum Requirements

5.5.2.2.2.1 3.84Mcps TDD Option

If the adjacent channel power is greater than -50dBm then the ACLR shall be better than the value specified in table 5.5.2.2.2.1.

The normative reference for this requirement is 3G TS 25.102 [1] clause 6.6.2.2.1.1.

Table 5.5.2.2.2.1: UE ACLR (3.84 Mcps TDD Option)

Power Class	Adjacent channel	ACLR limit
2, 3	UE-channel ± 5 MHz	-33 dB
2, 3	UE-Channel ± 10 MHz	-43 dB

5.5.2.2.2.2 1.28Mcps TDD Option

If the adjacent channel power is greater than -55dBm then the ACLR shall be better than the value specified in Table 5.5.2.2.2.2.

The normative reference for this requirement is 3G TS 25.102 [1] clause 6.6.2.2.1.2.

Table 5.5.2.2.2.2 :UE ACLR(1.28Mcps TDD Option)

Power Class	adjacent channel	ACLR limit
2, 3	UE channel \pm 1.6 MHz	-33 dB
2, 3	UE channel \pm 3.2 MHz	-43 dB

Note

1. The requirement shall still be met in the presence of switching transients.
2. The ACLR requirements reflect what can be achieved with present state of the art technology.
3. Requirement on the UE shall be reconsidered when the state of the art technology progresses.

5.5.2.2.3 Test purpose

The test purpose is to verify the ability of the UE to limit the interference produced by the transmitted signal to other UTRA receivers operating at the first or second adjacent RF channel.

5.5.2.2.4 Method of test

5.5.2.2.4.1 Initial conditions

- 1) Connect the SS to the UE antenna connector as shown in Figure A.1.
- 2) A call is set up according to the generic call setup procedure using parameters as specified in table E.3.1.2.
- 3) Enter the UE into loopback test mode and start the loopback test.

5.5.2.2.4.2 Procedure

- 1) Measure the wanted transmitted power of the active timeslot using the method in annex B.
- 2) Average over TBD time slots.
- 3) Measure interference power at the first lower adjacent RF channel (center frequency 5 MHz for 3.84 Mcps TDD Option and 1.6 MHz for 1.28 Mcps TDD Option, respectively, below the assigned channel frequency of the transmitted signal) over the useful part of the active TS with a measurement filter that has a RRC filter response with a roll off $\alpha = 0,22$ and a bandwidth equal to the chip rate.
- 4) Average over TBD time slots.
- 5) Calculate the ACLR by
Transmitted power acc. to 2) / interference power acc. to 4).
- 6) Repeat steps 3), 4) and 5) for the second lower adjacent RF channel (center frequency 10 MHz for the 3.84 Mcps TDD Option and 3.2 MHz for the 1.28 Mcps TDD Option, respectively, below the assigned channel frequency of the transmitted signal) and also for the first and second upper adjacent RF channel (center frequency 5 MHz for

[the 3.84 Mcps TDD Option and 1.6 MHz for the 1.28 Mcps TDD Option, respectively](#), and 10 MHz [for the 3.84 Mcps TDD Option and 3.2 MHz for the 1.28 Mcps TDD Option, respectively](#)).

5.5.2.2.5 Test requirements

[5.5.2.2.5.1 3.84 Mcps TDD Option](#)

The ACLR calculated in steps 5) and 6) of subclause 5.5.2.2.4.2 shall be equal or greater than the limits given in table [5.5.2.2.5.1 for the 3.84 Mcps TDD Option](#).

Table 5.5.2.2.5.1: UE ACLR ([3.84 Mcps TDD Option](#))

Power Class	Adjacent channel	ACLR limit
2, 3	UE-channel ± 5 MHz	-32.2 dB
2, 3	UE-Channel ± 10 MHz	-42.2 dB

NOTE: If the above Test Requirement differs from the Minimum Requirement then the Test Tolerance applied for this test is non-zero. The Test Tolerance for this test is defined in Annex F.2 and the explanation of how the Minimum Requirement has been relaxed by the Test Tolerance is given in Annex F

[5.5.2.2.5.2 1.28 Mcps TDD Option](#)

The ACLR calculated in steps 5) and 6) of subclause 5.5.2.2.4.2 shall be equal or greater than the limits given in table [5.5.2.2.5.2 for the 1.28 Mcps TDD Option](#).

Table 5.5.2.2.5.2: UE ACLR ([1.28 Mcps TDD Option](#))

Power Class	Adjacent channel	ACLR limit
2, 3	UE-channel ± 1.6 MHz	[-32.2] dB
2, 3	UE-Channel ± 3.2 MHz	[-42.2] dB

[NOTE: If the above Test Requirement differs from the Minimum Requirement then the Test Tolerance applied for this test is non-zero. The Test Tolerance for this test is defined in Annex F.2 and the explanation of how the Minimum Requirement has been relaxed by the Test Tolerance is given in Annex F](#)

5.5.3 Spurious emissions

5.5.3.1 Definition and applicability

Spurious emissions are emissions which are caused by unwanted transmitter effects such as harmonics emission, parasitic emission, intermodulation products and frequency conversion products, but exclude out of band emissions.

The frequency boundary and the detailed transitions of the limits between the requirement for out band emissions and spectrum emissions are based on ITU-R Recommendations SM.329 [8].

5.5.3.2 Minimum Requirements

[5.5.3.2.1 3.84 Mcps TDD Option](#)

These requirements are only applicable for frequencies which are greater than 12.5 MHz away from the UE center carrier frequency.

The normative reference for this requirement is 3G TS 25.102 [1] clause 6.6.3.1.1.

Table 5.5.3.2.1a: General Spurious emissions requirements (3.84 Mcps TDD Option)

Frequency Bandwidth	Resolution Bandwidth	Minimum requirement
$9 \text{ kHz} \leq f < 150 \text{ kHz}$	1 kHz	-36 dBm
$150 \text{ kHz} \leq f < 30 \text{ MHz}$	10 kHz	-36 dBm
$30 \text{ MHz} \leq f < 1000 \text{ MHz}$	100 kHz	-36 dBm
$1 \text{ GHz} \leq f < 12.75 \text{ GHz}$	1 MHz	-30 dBm

Table 5.5.3.2.1b: Additional Spurious emissions requirements (3.84 Mcps TDD Option)

Frequency Bandwidth	Resolution Bandwidth	Minimum requirement
$925 \text{ MHz} \leq f \leq 935 \text{ MHz}$	100 kHz	-67 dBm*
$935 \text{ MHz} < f \leq 960 \text{ MHz}$	100 kHz	-79 dBm*
$1805 \text{ MHz} \leq f \leq 1880 \text{ MHz}$	100 kHz	-71 dBm*

NOTE: The measurements are made on frequencies which are integer multiples of 200 kHz. As exceptions, up to five measurements with a level up to the applicable requirements defined in table 5.5.3.2.1b are permitted for each UARFCN used in the measurement.

5.5.3.2.2 1.28Mcps TDD Option

These requirements are only applicable for frequencies which are greater than 4 MHz away from the UE center carrier frequency.

The normative reference for this requirement is 3G TS 25.102 [1] clause 6.6.3.1.2.

Table 5.5.3.2.2a : General Spurious emissions requirements(1.28Mcps TDD Option)

<u>Frequency Bandwidth</u>	<u>Resolution Bandwidth</u>	<u>Minimum requirement</u>
<u>$9 \text{ kHz} \leq f < 150 \text{ kHz}$</u>	<u>1 kHz</u>	<u>-36 dBm</u>
<u>$150 \text{ kHz} \leq f < 30 \text{ MHz}$</u>	<u>10 kHz</u>	<u>-36 dBm</u>
<u>$30 \text{ MHz} \leq f < 1000 \text{ MHz}$</u>	<u>100 kHz</u>	<u>-36 dBm</u>
<u>$1 \text{ GHz} \leq f < 12.75 \text{ GHz}$</u>	<u>1 MHz</u>	<u>-30 dBm</u>

Table 5.5.3.2.2b : Additional Spurious emissions requirements(1.28Mcps TDD Option)

<u>Frequency Bandwidth</u>	<u>Resolution Bandwidth</u>	<u>Minimum requirement</u>
<u>$925 \text{ MHz} \leq f \leq 935 \text{ MHz}$</u>	<u>100 KHz</u>	<u>-67 dBm*</u>
<u>$935 \text{ MHz} < f \leq 960 \text{ MHz}$</u>	<u>100 KHz</u>	<u>-79 dBm*</u>
<u>$1805 \text{ MHz} \leq f \leq 1880 \text{ MHz}$</u>	<u>100 KHz</u>	<u>-71 dBm*</u>

Note: The measurements are made on frequencies which are integer multiples of 200 kHz. As exceptions, up to five measurements with a level up to the applicable requirements defined in Table 5.5.3.2.2b are permitted for each UARFCN used in the measurement.

5.5.3.3 Test purpose

5.5.3.3.1 3.84 Mcps Option

The test purpose is to verify the ability of the UE to limit the interference caused by unwanted transmitter effects to other systems operating at frequencies which are more than 12,5 MHz away from of the UE's carrier frequency.

5.5.3.3.2 1.28 Mcps Option

The test purpose is to verify the ability of the UE to limit the interference caused by unwanted transmitter effects to other systems operating at frequencies which are more than 4 MHz away from of the UE's carrier frequency.

5.5.3.4 Method of test

5.5.3.4.1 Initial conditions

- 1) Connect the SS to the UE antenna connector as shown in Figure A.1.
- 2) A call is set up according to the generic call setup procedure using parameters as specified in table E.3.1.2.
- 3) Enter the UE into loopback test mode and start the loopback test.

5.5.3.4.2 Procedure

Measure the power of the spurious emissions applying measurement filters with bandwidths as specified in the relevant tables of 5.5.3.2.1 for 3.84 Mcps TDD Option and tables 5.5.3.2.1 for 1.28 Mcps TDD Option, respectively. The characteristic of the filters shall be approximately Gaussian (typical spectrum analyzer filters). The center frequency of the filter shall be swept over the frequency bands as given in the tables. The sweep time shall be sufficiently low to capture the active time slots.

5.5.3.5 Test requirements

5.5.3.5.1 3.84 Mcps TDD Option

The spurious emissions measured according to subclause 5.5.3.4.2 shall not exceed the limits specified in the relevant tables of 5.5.3.5.1.a and 5.5.3.5.1.b

Table 5.5.3.5.1a: General Spurious emissions requirements

Frequency Bandwidth	Resolution Bandwidth	Test requirement
$9 \text{ kHz} \leq f < 150 \text{ kHz}$	1 kHz	-36 dBm
$150 \text{ kHz} \leq f < 30 \text{ MHz}$	10 kHz	-36 dBm
$30 \text{ MHz} \leq f < 1000 \text{ MHz}$	100 kHz	-36 dBm
$1 \text{ GHz} \leq f < 12.75 \text{ GHz}$	1 MHz	-30 dBm

Table 5.5.3.5.1b: Additional Spurious emissions requirements

Frequency Bandwidth	Resolution Bandwidth	Test requirement
$925 \text{ MHz} \leq f \leq 935 \text{ MHz}$	100 kHz	-67 dBm*
$935 \text{ MHz} < f \leq 960 \text{ MHz}$	100 kHz	-79 dBm*
$1805 \text{ MHz} \leq f \leq 1880 \text{ MHz}$	100 kHz	-71 dBm*

NOTE: The measurements are made on frequencies which are integer multiples of 200 kHz. As exceptions, up to five measurements with a level up to the applicable requirements defined in table 5.5.3.5.1b for the 3.84 Mcps TDD Option are permitted for each UARFCN used in the measurement.

NOTE: If the above Test Requirement differs from the Minimum Requirement then the Test Tolerance applied for this test is non-zero. The Test Tolerance for this test is defined in Annex F.2 and the explanation of how the Minimum Requirement has been relaxed by the Test Tolerance is given in Annex F.4.

5.5.3.5.2 1.28 Mcps TDD Option

The spurious emissions measured according to subclause 5.5.3.4.2 shall not exceed the limits specified in the relevant tables of 5.5.3.5.2a and 5.5.3.5.2b

Table 5.5.3.5.2a : General Spurious emissions requirements(1.28Mcps TDD Option)

<u>Frequency Bandwidth</u>	<u>Resolution Bandwidth</u>	<u>Test requirement</u>
<u>9 kHz ≤ f < 150 kHz</u>	<u>1 kHz</u>	<u>[-36] dBm</u>
<u>150 kHz ≤ f < 30 MHz</u>	<u>10 kHz</u>	<u>[-36] dBm</u>
<u>30 MHz ≤ f < 1000 MHz</u>	<u>100 kHz</u>	<u>[-36] dBm</u>
<u>1 GHz ≤ f < 12.75 GHz</u>	<u>1 MHz</u>	<u>[-30] dBm</u>

Table 5.5.3.5.2b : Additional Spurious emissions requirements(1.28Mcps TDD Option)

<u>Frequency Bandwidth</u>	<u>Resolution Bandwidth</u>	<u>Test -requirement</u>
<u>925 MHz ≤ f ≤ 935 MHz</u>	<u>100 KHz</u>	<u>[-67] dBm*</u>
<u>935 MHz < f ≤ 960 MHz</u>	<u>100 KHz</u>	<u>[-79] dBm*</u>
<u>1805 MHz ≤ f ≤ 1880 MHz</u>	<u>100 KHz</u>	<u>[-71] dBm*</u>

NOTE: The measurements are made on frequencies which are integer multiples of 200 kHz. As exceptions, up to five measurements with a level up to the applicable requirements defined in table 5.5.3.5.2b for the 1.28 Mcps TDD Option are permitted for each UARFCN used in the measurement.

NOTE: If the above Test Requirement differs from the Minimum Requirement then the Test Tolerance applied for this test is non-zero. The Test Tolerance for this test is defined in Annex F.2 and the explanation of how the Minimum Requirement has been relaxed by the Test Tolerance is given in Annex F.4.

5.6 Transmit Intermodulation

5.6.1 Definition and applicability

The transmit intermodulation performance is a measure of the capability of the transmitter to inhibit the generation of signals in its non linear elements caused by the presence of the wanted signal and an interfering signal reaching the transmitter via the antenna.

The UE intermodulation attenuation is defined by the ratio of the output power of the wanted signal to the output power of the intermodulation product when an interfering CW signal is added at a level below the wanted signal. Both the wanted signal power and the intermodulation product power are measured with a filter response that is root-raised cosine (RRC) with roll-off $\alpha=0.22$ and with a bandwidth equal to the chip rate.

The requirements of this test shall apply for all UTRA-UE.

5.6.2 Minimum Requirements

5.6.2.1 3.84 Mcps TDD Option

The requirement of transmitting intermodulation for carrier spacing 5 MHz is prescribed in the table below.

The normative reference for this requirement is 3G TS 25.102 [1] clause 6.7.1.1.

Table 5.6.2.1: Transmit Intermodulation (3.84 Mcps TDD Option)

Interference Signal Frequency Offset	5MHz	10MHz
Interference Signal Level	-40 dBc	
Interferer Modulation	CW Note: BS Test uses a CDMA modulated signal	
Minimum Requirement	-31dBc	-41dBc

5.6.2.2 1.28 Mcps TDD Option

The requirement of transmitting intermodulation for carrier spacing 1.6 MHz is prescribed in Table 5.6.2.2

The normative reference for this requirement is 3G TS 25.102 [1] clause 6.7.1.1.

Table 5.6.2.2 : Transmit Intermodulation (1.28Mcps TDD Option)

Interference Signal Frequency Offset	1.6 MHz	3.2 MHz
Interference Signal Level	-40 dBc	
Interferer Modulation	CW Note: BS Test uses a CDMA modulated signal	
Minimum Requirement	-31dBc	-41dBc

5.6.3 Test purpose

User Equipment(s) transmitting in close vicinity of each other can produce intermodulation products, which can fall into other UE, or BS receive band as an unwanted interfering signal.

It is the purpose of this test to limit interferences to the own and other systems due to intermodulation products.

5.6.4 Method of test

5.6.4.1 Initial conditions

- 1) Connect the SS and the interferer to the UE antenna connector as shown in Figure A.2.
- 2) A call is set up according to the generic call setup procedure using parameters as specified in table E.3.1.2.
- 3) Enter the UE into loopback test mode and start the loopback test.

Parameters of the interferer according to table 5.6.2.1 for 3.84 Mcps TDD Option and table 5.6.2.2 for 1.28 Mcps TDD Option, respectively.

5.6.4.2 Procedure

5.6.4.2.1 3.84 Mcps TDD Option

- 1) Measure the unwanted emissions according to 5.6.2. in a carrier offset spacing of 5 MHz and in a frequency range [5 MHz to 12.75 GHz], using an interferer +5MHz offset.

The frequency occupied by the interferer is excluded from the measurement.

- 2) Repeat 1) with the other 3 interferer-configurations (-5MHz, +10 MHz, -10 MHz).

- 3) Measure the wanted power according to annex B.
- 4) Display 1) and 2) in dBc with respect to 3).

5.6.4.2.2 1.28 Mcps TDD Option

1) Measure the unwanted emissions according to 5.6.2.2 in a carrier offset spacing of 1.6 MHz and in a frequency range [1.6 MHz to 12.75GHz], using an interferer +1.6MHz offset.

The frequency occupied by the interferer is excluded from the measurement.

- 2) Repeat 1) with the other 3 interferer-configurations (-1.6 MHz, +3.2 MHz, -3.2 MHz).
- 3) Measure the wanted power according to annex B.
- 4) Display 1) and 2) in dBc with respect to 3).

5.6.5 Test requirements

5.6.5.1 3.84 Mcps TDD Option

The results in 4) from subclause 5.6.4.2.1 shall not exceed the prescribed values in table 5.6.5.1.

Table 5.6.5.1: Transmit Intermodulation (3.84 Mcps TDD Option)

Interference Signal Frequency Offset	5MHz	10MHz
Interference Signal Level	-40 dBc	
Interferer Modulation	CW Note: BS Test uses a CDMA modulated signal	
<u>Minimum Requirement</u>	<u>[-31+TT]</u> dBc	<u>[-41+TT]</u> dBc

NOTE: If the above Test Requirement differs from the Minimum Requirement then the Test Tolerance applied for this test is non-zero. The Test Tolerance for this test is defined in Annex F.2 and the explanation of how the Minimum Requirement has been relaxed by the Test Tolerance is given in Annex F.4.

5.6.5.2 1.28 Mcps TDD Option

The results in 4) from subclause 5.6.4.2.2 shall not exceed the prescribed values in table 5.6.5.2.

Table 5.6.5.2 : Transmit Intermodulation (1.28Mcps TDD Option)

<u>Interference signal frequency offset</u>	<u>1.6MHz</u>	<u>3.2MHz</u>
<u>Interference signal level</u>	<u>[-40]dBc</u>	
<u>Minimum requirement of intermodulation products</u>	<u>[-31+TT]</u> dBc	<u>[-41+TT]</u> dBc

NOTE: If the above Test Requirement differs from the Minimum Requirement then the Test Tolerance applied for this test is non-zero. The Test Tolerance for this test is defined in Annex F.2 and the explanation of how the Minimum Requirement has been relaxed by the Test Tolerance is given in Annex F.4.

5.7 Transmit Modulation

5.7.1 Error Vector Magnitude

5.7.1.1 Definition and applicability

The Error Vector Magnitude (EVM) is a measure of the difference between the measured waveform and the theoretical modulated waveform (the error vector). It is the square root of the ratio of the mean error vector power to the mean reference signal power expressed as a %. The measurement interval is one timeslot.

The requirement of this subclause shall apply to all types of UTRA-UE.

5.7.1.2 Minimum Requirements

The Error Vector Magnitude shall not exceed 17.5 % for the parameters specified in Table 5.7.2.1.

Table 5.7.1.2.: Test parameters for Error Vector Magnitude/Peak Code Domain Error

Parameter	Level	Unit
UE Output Power	≥ -20	dBm
Operating conditions	Normal conditions	
Power control step size	1	dB

The normative reference for this requirement is TS 25.102 [1] subclause 6.8.2.1.

5.7.1.3 Test purpose

The transmitter shall generate a sufficient precise waveform, to enable the receiver to achieve the specified receiver performances.

5.7.1.4 Method of test

5.7.1.4.1 Initial conditions

- 1) Connect the SS to the UE antenna connector as shown in Figure A.1.
- 2) A call is set up according to the generic call setup procedure using parameters as specified in table E.3.1.2.
- 3) Enter the UE into loopback test mode and start the loopback test.

5.7.1.4.2 Procedure

- 1) Starting from the initial conditions, measure EVM (Error Vector Magnitude) of the UE according to annex B.
- 2) Set SS-level and signalling values such that the power level of the UE is between -20 and -19 dBm
- 3) Measure EVM of the UE according to annex B.

5.7.1.5 Test requirements

The results in step 1) and 2) shall not exceed 17.5% for parameters specified in table 5.7.1.2.

NOTE: If the above Test Requirement differs from the Minimum Requirement then the Test Tolerance applied for this test is non-zero. The Test Tolerance for this test is defined in Annex F.2 and the explanation of how the Minimum Requirement has been relaxed by the Test Tolerance is given in Annex F.4.

5.7.2 Peak code domain error

5.7.2.1 Definition and applicability

The code domain error is computed by projecting the error vector power onto the code domain at a specific spreading factor. The error power for each code is defined as the ratio to the mean power of the projection onto the code, to the mean power of the composite reference waveform expressed in dB. And the Peak Code Domain Error is defined as the maximum value for Code Domain Error. The measurement interval is one timeslot.

This specification is applicable for multi-code transmission only.

The requirement of this test applies to all UTRA-UE, applicable for multi-code transmission.

5.7.2.2 Minimum Requirement

The peak code domain error shall not exceed -21dB at spreading factor 16.

The normative reference for this requirement is TS 25.102 [1] subclause 6.8.3.1.

5.7.2.3 Test purpose

It is the purpose of this test to limit crosstalk among codes.

5.7.2.4 Method of test

5.7.2.4.1 Initial conditions

5.7.2.4.1.1 3.84 Mcps TDD Option

- 1) Connect the SS to the UE antenna connector as shown in Figure A.1.
- 2) A call is set up according to the generic call setup procedure using parameters as specified in table 5.7.2.4.1.1 for the 3.84 Mcps TDD Option.
- 3) Enter the UE into loopback test mode and start the loopback test.

Table 5.7.2.4.1.1: Test parameters for Peak code Domain Error (3.84 Mcps TDD Option)

Parameter	Value/description
Reference measurement channel	Multicode 12.2kbps, according to annex C.2.2.1
Uplink Power Control	SS level and signalling values such that UE transmits maximum power
Data content	real life (sufficient irregular)

5.7.2.4.1.2 1.28 Mcps TDD Option

- 1) Connect the SS to the UE antenna connector as shown in Figure A.1.
- 2) A call is set up according to the generic call setup procedure using parameters as specified in table 5.7.2.4.1.2 for the 1.28 Mcps TDD Option.
- 3) Enter the UE into loopback test mode and start the loopback test.

Table 5.7.2.4.1.2: Test parameters for Peak code Domain Error (1.28 Mcps TDD Option)

<u>Parameter</u>	<u>Value/description</u>
<u>Reference measurement channel</u>	<u>Multicode 12.2kbps, according to annex C.2.2.2</u>
<u>Uplink Power Control</u>	<u>SS level and signalling values such that UE transmits maximum power</u>
<u>Data content</u>	<u>real life (sufficient irregular)</u>

5.7.2.4.2 Procedure

- 1) Starting from the initial conditions, measure peak code error(PCDE)of the UE according to annex B.
- 2) Set SS-level and signalling values such that the power level of the UE is between -20 and -19 dBm
- 3) Measure PCDE of the UE according to annex B.

5.7.2.5 Test requirements

The results in step 1) and 2) shall not exceed -20 dB, for parameters specified in table 5.7.1.2.

Note: If the above Test Requirement differs from the Minimum Requirement then the Test Tolerance applied for this test is non-zero. The Test Tolerance for this test is defined in Annex F.2 and the explanation of how the Minimum Requirement has been relaxed by the Test Tolerance is given in Annex F.4.

6 Receiver Characteristics

6.1 General

Receiving performance test of the UE is implemented during communicating with the SS via air interface. The procedure uses normal call protocol until the UE is communicating on traffic channel basically. (Refer to TS 34.108 [3] Common Test Environments for User Equipment (UE) Conformance Testing) On the traffic channel, the UE provides special function for testing that is described in Logical Test Interface and the UE is tested using this function. (Refer to TS 34.109 [3] Logical Test Interface (FDD/TDD) Special conformance testing functions)

Unless otherwise stated the receiver characteristics are specified at the antenna connector of the UE. For UE(s) with an integral antenna only, a reference antenna with a gain of 0 dBi is assumed. UE with an integral antenna may be taken into account by converting these power levels into field strength requirements, assuming a 0 dBi gain antenna. Receiver characteristics for UE(s) with multiple antennas/antenna connectors are for further study.

The UE antenna performance has a significant impact on system performance, and minimum requirements on the antenna efficiency are therefore intended to be included in future versions of this specification. It is recognized that different requirements and test methods are likely to be required for the different types of UE.

All the parameters in clause 6 are defined using the DL reference measurement channel (12.2 kbps) specified in subclause C.3.3.

6.2 Reference sensitivity level

6.2.1 Definition and applicability

The reference sensitivity is the minimum receiver input power measured at the antenna connector at which the BER does not exceed the specific value.

The requirements in this subclause shall apply to all types of UTRA UE.

6.2.2 Minimum Requirements

6.2.2.1 3.84 Mcps TDD Option

For the DL reference measurement channel 12.2 kBit/s specified in annex C, the BER shall not exceed 0.001 for the parameters specified in Table 6.2.2.1.

Table 6.2.2.1. Test parameters for reference sensitivity (3.84 Mcps TDD Option)

Parameter	Level	Unit
$\frac{\Sigma DPCH_Ec}{I_{or}}$	0	dB
\hat{I}_{or}	-105	dBm/3.84 MHz

The normative reference for this requirement is TS 25.102 [1] subclause 7.3.1.1.

6.2.2.2 1.28 Mcps TDD Option

The BER shall not exceed 0.001 for the parameters specified in Table 6.2.2.2.

Table 6.2.2.2 : Test parameters for reference sensitivity(1.28Mcps TDD Option)

Parameter	Level	Unit
$\frac{\Sigma DPCH_Ec}{I_{or}}$	0	dB
\hat{I}_{or}	-108	dBm/1.28 MHz

The normative reference for this requirement is TS 25.102 [1] subclause 7.3.1.2.

6.2.3 Test purpose

The test purpose is to verify the ability of the UE to receive a prescribed test signal at the lower end of the dynamic range under defined conditions (no interference, no multipath propagation) with a BER not exceeding a specified level. This test is also used as a reference case for other tests to allow the assessment of degradations due to various sources of interference.

6.2.4 Method of test

6.2.4.1 Initial conditions

- 1) Connect the SS to the UE antenna connector as shown in Figure A.3.
- 2) A call is set up according to the Generic call setup procedure..
- 3) Enter the UE into loopback test mode and start the loopback test.
- 4) The level of SS output signal measured at the UE antenna connector shall be -105 dBm for the 3.84 Mcps TDD Option and -108 dBm for the 1.28 Mcps TDD Option, respectively.

6.2.4.2 Procedure

- 1) Measure the BER of DCH received from the UE at the SS.

6.2.5 Test requirements

6.2.5.1 3.84 Mcps TDD Option

The measured BER, derived in step 1), shall not exceed 0.001 under conditions described in Table 6.2.5.1 for the 3.84 Mcps TDD Option.

Table 6.2.5.1. Test parameters for reference sensitivity (3.84 Mcps TDD Option)

Parameter	Level	Unit
$\frac{\Sigma DPCH_{Ec}}{I_{or}}$	0	dB
\hat{I}_{or}	-104.3	dBm/3.84 MHz

NOTE: If the above Test Requirement differs from the Minimum Requirement then the Test Tolerance applied for this test is non-zero. The Test Tolerance for this test is defined in Annex F.2 and the explanation of how the Minimum Requirement has been relaxed by the Test Tolerance is given in Annex F.4.

6.2.5.2 1.28 Mcps TDD Option

The measured BER, derived in step 1), shall not exceed 0.001 under conditions described in Table 6.2.5.2 for the 1.28 Mcps TDD Option.

Table 6.2.5.2. Test parameters for reference sensitivity (1.28 Mcps TDD Option)

Parameter	Level	Unit
$\frac{\Sigma DPCH_{Ec}}{I_{or}}$	<u>0</u>	<u>dB</u>
\hat{I}_{or}	<u>[-107.3]</u>	<u>dBm/1.28 MHz</u>

NOTE: If the above Test Requirement differs from the Minimum Requirement then the Test Tolerance applied for this test is non-zero. The Test Tolerance for this test is defined in Annex F.2 and the explanation of how the Minimum Requirement has been relaxed by the Test Tolerance is given in Annex F.4.

6.3 Maximum Input Level

6.3.1 Definition and applicability

This is defined as the maximum receiver input power, measured at the antenna connector, which does not degrade the specified BER performance.

The requirements in this subclause shall apply to all types of UTRA UE.

6.3.2 ~~Minimum Conformance~~ requirements

6.3.2.1 3.84 Mcps TDD Option

The BER shall not exceed 0,001 for the parameters specified in table 6.3.2.1.

Table 6.3.2.1: Maximum input level (3.84 Mcps TDD Option)

Parameter	Level	Unit
$\frac{\Sigma \text{DPCH_Ec}}{I_{\text{or}}}$	-7	dB
\hat{I}_{or}	-25	dBm/3.84 MHz

The reference for this requirement is TS 25.102 [1] subclause 7.4.1.1.

6.3.2.2 1.28 Mcps TDD Option

The BER shall not exceed 0.001 for the parameters specified in Table 6.3.2.2.

Table 6.3.2.2: Maximum input level(1.28Mcps TDD Option)

<u>Parameter</u>	<u>Level</u>	<u>Unit</u>
$\frac{\Sigma \text{DPCH_Ec}}{I_{\text{or}}}$	<u>-7</u>	<u>dB</u>
\hat{I}_{or}	<u>-25</u>	<u>dBm/1.28 MHz</u>

The reference for this requirement is TS 25.102 [1] subclause 7.4.1.2.

6.3.3 Test purpose

The test purpose is to verify the ability of the UE to receive a prescribed test signal at the upper end of the dynamic range under defined conditions (no interference, no multipath propagation) with BER not exceeding a specified value.

6.3.4 Method of test

6.3.4.1 Initial conditions

- 1) Connect the SS to the UE antenna connector as shown in Figure A.3.
- 2) A call is set up according to the Generic call setup procedure.
- 3) Enter the UE into loopback test mode and start the loopback test.
- 4) The level of SS output signal measured at the UE antenna connector shall be according to table 6.3.2. [1\(3.84 Mcps TDD Option\)](#) and [table 6.3.2.2\(1.28 Mcps TDD Option\)](#), respectively.

6.3.4.2 Procedure

Measure the BER of DCH received from the UE at the SS.

6.3.5 Test requirements

The measured BER, derived in step 1), shall not exceed 0,001.

6.4 Adjacent Channel Selectivity (ACS)

6.4.1 Definition and applicability

Adjacent Channel Selectivity is a measure of a receiver's ability to receive a wanted signal at its assigned channel frequency in the presence of an adjacent channel signal.

The requirements of this test apply to all UTRA UE.

6.4.2 Minimum Requirements

[6.4.2.1 3.84 Mcps TDD Option](#)

For the UE of power class 2 and 3, the BER shall not exceed 0,001 for parameters specified in table 6.4.2. This test condition is equivalent to the ACS value 33 dB.

Table 6.4.2.1: Test parameters for Adjacent Channel Selectivity [\(3.84 Mcps TDD Option\)](#)

Parameter	Unit	Level
$\frac{\Sigma DPCH_Ec}{I_{or}}$	dB	0
I_{or}	dBm/3.84 MHz	-91
I_{oac}	dBm/3.84 MHz	-52
F_{UW} offset	MHz	+5 or -5

Explanatory note:

Within the reference sensitivity BER= 0.001 corresponds to a test signal = -105 dBm/3.84 MHz and a noise level -99 dBm /3.84 MHz BW (S/I -6 dB)

Within ACS BER=0.001 is directly verified

Known from the reference sensitivity, this corresponds to S/I -6dB in the wanted BW.

As a wanted signal of -91 dBm applied, an in-channel-interfering-signal of -85 dBm can be assumed.

Verifying a filter suppression of 33 dB indirectly, an adjacent-channel-interferer of -52 dBm is needed

The normative reference of this requirement is TS 25.102 [1] subclause 7.5.

6.4.2.2 1.28 Mcps TDD Option

For the UE of power class 2 and 3, the BER shall not exceed 0,001 for parameters specified in table 6.4.2.2. This test condition is equivalent to the ACS value 33 dB.

Table 6.4.2.2: Test parameters for Adjacent Channel Selectivity (1.28Mcps TDD Option)

<u>Parameter</u>	<u>Unit</u>	<u>Level</u>
$\frac{\Sigma DPCH_Ec}{I_{or}}$	<u>dB</u>	<u>0</u>
\hat{I}_{or}	<u>dBm/1.28MHz</u>	<u>-91</u>
I_{oac}	<u>dBm/1.28 MHz</u>	<u>-54</u>
E_{uw_offset}	<u>MHz</u>	<u>+1.6 or -1.6</u>

Explanatory note:

Within the reference sensitivity BER= 0.001 corresponds to a testsignal = [-108 dBm]/1.28 MHz and a noise level [-104 dBm] /1.28 MHz BW (S/I -4 dB)

Within ACS BER=0.001 is directly verified

Known from the reference sensitivity, this corresponds to S/I -4dB in the wanted BW.

As a wanted signal of -91 dBm applied, an in-channel-interfering-signal of [-87 dBm] can be assumed.

Verifying a filter suppression of 33 dB indirectly, an adjacent-channel-interferer of [-54 dBm] is needed

The normative reference of this requirement is TS 25.102 [1] subclause 7.5.1.2

6.4.3 Test purpose

The test purpose is to verify the ability of the UE-receiver to sufficiently suppress the interfering signal in the channel adjacent to the wanted channel.

6.4.4 Method of test

6.4.4.1 Initial conditions

- 1) Connect the SS and the interferer to the UE antenna connector as shown in Figure A.4.
- 2) A call is set up according to the Generic call setup procedure.
- 3) Enter the UE into loopback test mode and start the loopback test.

- 4) Set the signal generator to produce an interference signal. The interference signal shall be equivalent to a continuously running wideband CDMA signal with one code and chip frequency 3.84 Mchp/s [for the 3.84 Mcps TDD Option and 1.28 Mchp/s for the 1.28 Mcps TDD Option, respectively](#) and rolloff 0.22.

6.4.4.2 Procedure

- 1) Set the interference signal 5 MHz [for the 3.84 Mcps TDD Option and 1.6 MHz for the 1.28 Mcps TDD Option, respectively](#) above the assigned channel frequency of the wanted signal.
- 2) Measure the BER of the wanted signal received from the UE at the SS.
- 3) Set the interference signal 5 MHz [for the 3.84 Mcps TDD Option and 1.6 MHz for the 1.28 Mcps TDD Option, respectively](#), below the assigned channel frequency of the wanted signal and repeat 2).

6.4.5 Test Requirements

6.4.5.1 3.84 Mcps TDD Option

The measured BER, derived in step 2), shall not exceed 0,001 under conditions described in table 6.4.5.1 [for the 3.84 Mcps TDD Option](#).

Table 6.4.5.1: Test parameters for Adjacent Channel Selectivity (3.84 Mcps TDD Option)

Parameter	Unit	Level
$\frac{\Sigma DPCH_Ec}{I_{or}}$	dB	0
\hat{I}_{or}	dBm/3.84 MHz	-91
I_{oac}	dBm/3.84 MHz	-52
F_{uw} offset	MHz	+5 or -5

NOTE: If the above Test Requirement differs from the Minimum Requirement then the Test Tolerance applied for this test is non-zero. The Test Tolerance for this test is defined in Annex F.2 and the explanation of how the Minimum Requirement has been relaxed by the Test Tolerance is given in Annex F.4.

6.4.5.2 1.28 Mcps TDD Option

The measured BER, derived in step 2), shall not exceed 0,001 under conditions described in table 6.4.5.2 [for the 1.28 Mcps TDD Option](#).

Table 6.4.5.2: Test parameters for Adjacent Channel Selectivity (1.28Mcps TDD Option)

<u>Parameter</u>	<u>Unit</u>	<u>Level</u>
$\frac{\Sigma DPCH_Ec}{I_{or}}$	<u>dB</u>	<u>0</u>
\hat{I}_{or}	<u>dBm/1.28MHz</u>	<u>[-91]</u>
I_{oac}	<u>dBm/1.28 MHz</u>	<u>[-54]</u>
F_{uw_offset}	<u>MHz</u>	<u>[+1.6 or -1.6]</u>

NOTE: If the above Test Requirement differs from the Minimum Requirement then the Test Tolerance applied for this test is non-zero. The Test Tolerance for this test is defined in Annex F.2 and the explanation of how the Minimum Requirement has been relaxed by the Test Tolerance is given in Annex F.4.

6.5 Blocking Characteristics

6.5.1 Definition and applicability

The blocking characteristics is a measure of the receiver ability to receive a wanted signal at its assigned channel frequency in the presence of an unwanted interferer on frequencies other than those of the spurious response or the adjacent channels without this unwanted input signal causing a degradation of the performance of the receiver beyond a specified limit.. The blocking performance shall apply at all frequencies except those at which a spurious response occur.

The requirements of this test apply to all UTRA UE

6.5.2 Minimum Requirements

6.5.2.1 3.84 Mcps TDD Option

The BER shall not exceed 0,001 for the parameters specified in table 6.5.2a and table 6.5.2b. For table 6.5.2b up to 24 exceptions are allowed for spurious response frequencies in each assigned frequency channel when measured using a 1MHz step size for the interference signal.

The normative reference for this requirement is 3G TS 25.102 clause 7.6.1.1.

Table 6.5.2.1a: In-band blocking (3.84 Mcps TDD Option)

Parameter	Offset 1	Offset 2	Unit
$\frac{\Sigma DPCH_Ec}{I_{or}}$	0	0	dB
I_{or}	<REFSENS> + 3 dB	<REFSENS> + 3 dB	dBm/3.84 MHz
$I_{blocking}$ (modulated)	-56	-44	dBm/3.84 MHz
F_{UW} offset	+10 or -10	+15 or -15	MHz

Table 6.5.2.1b: Out of band blocking (3.84 Mcps TDD Option)

Parameter	Band 1	Band 2	Band 3	Unit
$\Sigma DPCH - E_c$	0	0	0	dB
I_{or}	<REFSENS> + 3 dB	<REFSENS> + 3 dB	<REFSENS> + 3 dB	dBm/3.84 MHz
$I_{blocking}$ (CW)	-44	-30	-15	dBm
F_{UW} For operation in frequency bands as defined in subclause 4.2(a)	1840 <f < 1885 1935 <f < 1995 2040 <f < 2085	1815 <f < 1840 2085 <f < 2110	1 <f < 1815 2110 <f < 12750	MHz
F_{UW} For operation in frequency bands as defined in subclause 4.2(b)	1790 <f < 1835 2005 <f < 2050	1765 <f < 1790 2050 <f < 2075	1 <f < 1765 2075 <f < 12750	MHz
F_{UW} For operation in frequency bands as defined in subclause 4.2(c)	1850 <f < 1895 1945 <f < 1990	1825 <f < 1850 1990 <f < 2015	1 <f < 1825 2015 <f < 12750	MHz

- Note:
1. For operation referenced in 4.2(a), from 1885 <f < 1900 MHz, 1920 <f < 1935 MHz, 1995 <f < 2010 MHz and 2025 <f < 2040 MHz, the appropriate in-band blocking or adjacent channel selectivity in section 6.4.2.1 shall be applied.
 2. For operation referenced in 4.2(b), from 1835 <f < 1850 MHz and 1990 <f < 2005 MHz, the appropriate in-band blocking or adjacent channel selectivity in section 6.4.2.1 shall be applied.
 3. For operation referenced in 4.2(c), from 1895 <f < 1910 MHz and 1930 <f < 1945 MHz, the appropriate in-band blocking or adjacent channel selectivity in section 6.4.2.1 shall be applied.

6.5.2.2 1.28 Mcps TDD Option

The BER shall not exceed 0.001 for the parameters specified in table 6.5.2.2a and table 6.5.2.2b.

The normative reference for this requirement is 3G TS 25.102 [1] clause 7.6.1.2.

Table 6.5.2.2a: In-band blocking(1.28Mcps TDD Option)

Parameter	Offset	Offset	Unit
<u>Wanted Signal Level</u>	<REFSENS> + 3 dB	<REFSENS> + 3 dB	dBm/1.28 MHz
<u>Unwanted Signal Level (modulated)</u>	-61	-49	dBm/1.28 MHz
<u>F_{UW} (offset)</u>	+3.2 or -3.2	+4.8 or -4.8	MHz

Table 6.5.2.2b: Out of band blocking(1.28Mcps TDD Option)

<u>Parameter</u>	<u>Band 1</u>	<u>Band 2</u>	<u>Band 3</u>	<u>Unit</u>
<u>Wanted Signal Level</u>	<u><REFSENS> + 3 dB</u>	<u><REFSENS> + 3 dB</u>	<u><REFSENS> + 3 dB</u>	<u>dBm/1.28 MHz</u>
<u>Unwanted Signal Level (CW)</u>	<u>-44</u>	<u>-30</u>	<u>-15</u>	<u>dBm</u>
<u>F_{uw}</u> <u>For operation in frequency bands as defined in subclause 4.2(a)</u>	<u>1840 <f <1895.2</u> <u>1924.8 <f <2005.2</u> <u>2029.8 <f <2085</u>	<u>1815 <f <1840</u> <u>2085 <f <2110</u>	<u>1 <f <1815</u> <u>2110 <f <12750</u>	<u>MHz</u>
<u>F_{uw}</u> <u>For operation in frequency bands as defined in subclause 4.2(b)</u>	<u>1790 <f < 1845.2</u> <u>1994.8 <f < 2050</u>	<u>1765 <f < 1790</u> <u>2050 <f < 2075</u>	<u>1 <f < 1765</u> <u>2075 <f < 12750</u>	<u>MHz</u>
<u>F_{uw}</u> <u>For operation in frequency bands as defined in subclause 4.2(c)</u>	<u>1850 <f < 1905.2</u> <u>1934.8 <f < 1990</u>	<u>1825 <f < 1850</u> <u>1990 <f < 2015</u>	<u>1 <f < 1825</u> <u>2015 <f < 12750</u>	<u>MHz</u>

- Note: 1. For operation referenced in 4.2(a), from 1895.2 <f < 1900 MHz, 1920 <f < 1924.8 MHz, 2005.2 <f < 2010 MHz and 2025 <f < 2029.8 MHz, the appropriate in-band blocking or adjacent channel selectivity in section 6.4.2.2 shall be applied.
2. For operation referenced in 4.2(b), from 1845.2 <f < 1850 MHz and 1990 <f < 1994.8 MHz, the appropriate in-band blocking or adjacent channel selectivity in section 6.4.2.2 shall be applied.
3. For operation referenced in 4.2(c), from 1905.2 <f < 1910 MHz and 1930 <f < 1934.8 MHz, the appropriate in-band blocking or adjacent channel selectivity in section 6.4.2.2 shall be applied.

6.5.3 Test purpose

"The test stresses the ability of the UE receiver to withstand high-level interference from unwanted signals at frequency offsets of 10 MHz or more, without undue degradation of its sensitivity."

6.5.4 Method of test

6.5.4.1 Initial conditions

- 1) Connect the SS and the interfering Signal generator to the antenna connector as shown in Figure A.5.
- 2) A call is set up according to the Generic call setup procedure
- 3) Enter the UE into loopback test mode and start the loopback test.

6.5.4.2 Procedure

- 1) The wanted signal frequency channel is set into the middle of the band.
- 2) The interfering Signal Generator is stepped through the frequency range indicated in table 6.5.2.1a [for the 3.84 Mcps TDD Option and table 6.5.2.2a for the 1.28 Mcps TDD Option, respectively](#); with a step size of 1 MHz.
- 3) The interference signal shall be equivalent to a continuously running wideband CDMA signal with one code and chip frequency 3.84 Mchip/s [for the 3.84 Mcps TDD Option and 1.28 Mchip/s for the 1.28 Mcps TDD Option, respectively](#) and rolloff 0.22.
- 4) Measure the BER of the wanted signal received from the UE at the SS for each step of the interferer.
- 5) Repeat the inband blocking for wanted frequency channels low-band and high-band.
- 6) The wanted signal frequency channel is set into the middle of the band.
- 7) The interfering Signal Generator is stepped through the frequency range indicated in table 6.4.2.1.b [for the 3.84 Mcps TDD Option and table 6.4.2.2b for the 1.28 Mcps TDD Option, respectively](#) with a step size of 1 MHz.
- 8) The interference signal is a CW signal.
- 9) Measure the BER of the wanted signal received from the UE at the SS for each step of the interferer.

NOTE: Due to the large amount of time-consuming BER tests it is recommended to speed up a single BER test by reducing the 0.001-BER confidence level [10 000 bits under test or 10 errors] for screening the critical frequencies. Critical frequencies must be identified using standard BER confidence level. [30 000 bits or 30 errors].

6.5.5 Test requirements

6.5.5.1 3.84 Mcps TDD Option

The measured BER, derived in step 4) and 5), shall not exceed 0,001 (without exception) under test conditions described in table 6.5.5.1a.

The measured BER, derived in step 9), shall not exceed 0,001 except for up to 24 different frequencies of the interfering signal under test conditions described in table 6.5.5.1b.

These frequencies are further processed in subclause 6.6 Spurious response.

Table 6.5.5.1a: Test conditions In-band blocking (3.84 Mcps TDD Option)

Parameter	Offset 1	Offset 2	Unit
$\frac{\Sigma DPCH_Ec}{I_{or}}$	0	0	dB
I_{or}	<REFSENS> + 3 dB	<REFSENS> + 3 dB	dBm/3.84 MHz
$I_{blocking}$ (modulated)	-56	-44	dBm/3.84 MHz

Table 6.5.5.1b: Test conditions Out of band blocking (3.84 Mcps TDD Option)

Parameter	Band 1	Band 2	Band 3	Unit
$\frac{\Sigma DPCH_Ec}{I_{or}}$	0	0	0	dB
I_{or}	<REFSENS> + 3 dB	<REFSENS> + 3 dB	<REFSENS> + 3 dB	dBm/3.84 MHz
$I_{blocking}$ (CW)	-44	-30	-15	dBm

NOTE: If the above Test Requirement differs from the Minimum Requirement then the Test Tolerance applied for this test is non-zero. The Test Tolerance for this test is defined in Annex F.2 and the explanation of how the Minimum Requirement has been relaxed by the Test Tolerance is given in Annex F.4

6.5.5.2 1.28 Mcps TDD Option

The measured BER, derived in step 4) and 5), shall not exceed 0,001 (without exception) under test conditions described in table 6.5.5.2a.

The measured BER, derived in step 9), shall not exceed 0,001 except for up to 24 different frequencies of the interfering signal under test conditions described in table 6.5.5.2b.

These frequencies are further processed in subclause 6.6 Spurious response.

Table 6.5.5.2a: Test conditions In-band blocking (1.28 Mcps TDD Option)

Parameter	Offset 1	Offset 2	Unit
$\frac{\Sigma PCH_Ec}{I_{or}}$	0	0	dB
I_{or}	[<REFSENS> + 3 dB]	[<REFSENS> + 3 dB]	dBm/1.28 MHz
$I_{blocking}$ (modulated)	[-56]	[-44]	dBm/1.28 MHz

Table 6.5.5.2b: Test conditions Out of band blocking (3.84 Mcps TDD Option)

Parameter	Band 1	Band 2	Band 3	Unit
$\frac{\Sigma PCH_Ec}{I_{or}}$	0	0	0	dB
I_{or}	[<REFSENS> + 3 dB]	[<REFSENS> + 3 dB]	[<REFSENS> + 3 dB]	dBm/1.28 MHz
$I_{blocking}$ (CW)	[-44]	[-30]	[-15]	dBm

NOTE: If the above Test Requirement differs from the Minimum Requirement then the Test Tolerance applied for this test is non-zero. The Test Tolerance for this test is defined in Annex F.2 and the explanation of how the Minimum Requirement has been relaxed by the Test Tolerance is given in Annex F.4

6.6 Spurious Response

6.6.1 Definition and applicability

Spurious response is a measure of the receiver's ability to receive a wanted signal on its assigned channel frequency without exceeding a given degradation due to the presence of an unwanted CW interfering signal at any other frequency at which a response is obtained i.e. for which the blocking limit is not met.

The requirements of this test apply to all types of UTRA for the UE.

6.6.2 Minimum Requirements

6.6.2.1 3.84 Mcps TDD Option

The BER shall not exceed 0,001 for the parameters specified in table 6.6.2.1.

The normative reference for this requirement is 3G TS 25.102 clause 7.7.1.1.

Table 6.6.2.1: Spurious Response (3.84 Mcps TDD Option)

Parameter	Value	Unit
$\frac{\Sigma DPCH - Ec}{I_{or}}$	0	dB
\hat{I}_o	<REFSENS> + 3	dBm/3.84 MHz
I _{blocking} (CW)	-44	dBm
F _{uw}	Spurious response frequencies	MHz

6.6.2.2 1.28 Mcps TDD Option

The BER shall not exceed 0.001 for the parameters specified in Table 6.6.2.2.

Table 6.6.2.2: Spurious Response (1.28Mcps TDD Option)

Parameter	Level	Unit
Wanted Signal Level	<REFSENS> + 3 dB	dBm/1.28 MHz
Unwanted Signal Level (CW)	-44	dBm
F _{uw}	Spurious response frequencies	MHz

6.6.3 Test purpose

Spurious response frequencies, identified in the blocking test, are measured against a less stringent test requirement. The test stresses the ability of the receiver to withstand high level interference signals without undue degradation of its sensitivity due to the receiver's frequency conversion concept.

6.6.4 Method of test

6.6.4.1 Initial conditions

- 1) Connect the SS and the unwanted signal to the UE antenna connector as shown in Figure A.6.
- 2) A call is set up according to the Generic call setup procedure.
- 3) Enter the UE into loopback test mode and start the loopback test.

6.6.4.2 Procedure

- 1) Repeat the wanted signal frequency setting from the blocking test. Set the level according to table 6.6.2.1 for the 3.84 Mcps TDD Option and table 6.6.2.2 for the 1.28 Mcps TDD Option, respectively.
- 2) Repeat the frequency settings of the interferer signal, at which the blocking test failed. Set the level according to table 6.6.5.1 for the 3.84 Mcps TDD Option and table 6.6.5.2 for the 1.28 Mcps TDD Option, respectively.
- 3) Measure the BER of DCH received from the UE at the SS for each of the settings 1) and 2).

6.6.5 Test requirements

6.6.5.1 3.84 Mcps TDD

The measured BER, derived in step 3), shall not exceed 0,001 under test conditions described in Table 6.6.5.1 for the 3.84 Mcps TDD Option.

Table 6.6.5.1: Test Parameters Spurious Response (3.84 Mcps TDD Option)

Parameter	Value	Unit
$\frac{\Sigma DPCH - Ec}{I_{or}}$	0	dB
\hat{I}_o	<REFSENS> + 3	dBm/3.84 MHz
$I_{blocking} (CW)$	-44	dBm
F_{uw}	Spurious response frequencies	MHz

NOTE: If the above Test Requirement differs from the Minimum Requirement then the Test Tolerance applied for this test is non-zero. The Test Tolerance for this test is defined in Annex F.2 and the explanation of how the Minimum Requirement has been relaxed by the Test Tolerance is given in Annex F.4.

6.6.5.2 1.28 Mcps TDD

The measured BER, derived in step 3), shall not exceed 0,001 under test conditions described in Table 6.6.5.2 for the 1.28 Mcps TDD Option.

Table 6.6.5.2: Test Parameters Spurious Response (1.28 Mcps TDD Option)

Parameter	Value	Unit
$\frac{\Sigma DPCH - Ec}{I_{or}}$	0	dB
\hat{I}_o	[<REFSENS> + 3]	dBm/1.28 MHz
$I_{blocking} (CW)$	[-44]	dBm
F_{uw}	Spurious response frequencies	MHz

NOTE: If the above Test Requirement differs from the Minimum Requirement then the Test Tolerance applied for this test is non-zero. The Test Tolerance for this test is defined in Annex F.2 and the explanation of how the Minimum Requirement has been relaxed by the Test Tolerance is given in Annex F.4.

6.7 Intermodulation Characteristics

6.7.1 Definition and applicability

Third and higher order mixing of the two interfering RF signals can produce an interfering signal in the band of the desired channel. Intermodulation response rejection is a measure of the capability of the receiver to receiver a wanted signal on its assigned channel frequency in the presence of two or more interfering signals which have a specific frequency relationship to the wanted signal.

The requirements of this test shall apply to all UTRA UE.

6.7.2 Minimum Requirements

6.7.2.1 3.84 Mcps TDD Option

The BER shall not exceed 0,001 for the parameters specified in table 6.7.2.1

The normative reference for this requirement is 3G TS 25.102 subclause 7.8.1.1.

Table 6.7.2.1: Receive intermodulation characteristics (3.84 Mcps TDD Option)

Parameter	Value	Unit
$\frac{\Sigma DPCH_Ec}{I_{or}}$	0	dB
\hat{I}_{or} Wanted Signal Level	<REFSENS> + 3 dB	dBm/3.84 MHz
I_{ouw1} (CW)	-46	dBm
I_{ouw2} (modulated)	-46	dBm/3.84 MHz
F_{uw1} (CW)	±10	MHz
F_{uw2} (Modulated)	±20	MHz

6.7.2.2 1.28 Mcps TDD Option

The BER shall not exceed 0.001 for the parameters specified in table 6.7.2.2.

The normative reference for this requirement is 3G TS 25.102 subclause 7.8.1.2.

Table 6.7.2.2: Receive intermodulation characteristics(1.28Mcps TDD Option)

Parameter	Level	Unit
$\frac{\Sigma DPCH_Ec}{I_{or}}$	0	dB
\hat{I}_{or}	<REFSENS> + 3 dB	dBm/1.28 MHz
I_{ouw1} (CW)	-46	dBm
I_{ouw2} (modulated)	-46	dBm/1.28 MHz
F_{uw1} (CW)	3.2	MHz
F_{uw2} (Modulated)	6.4	MHz

6.7.3 Test purpose

The test stresses the ability of the receiver to withstand two or more high level interference signals without undue degradation of its sensitivity due to the receiver's non-linear elements.

6.7.4 Method of test

6.7.4.1 Initial conditions

- 1) Connect the SS and the unwanted signals to the UE antenna connector as shown in Figure A.7.

- 2) A call is set up according to the Generic call setup procedure.
- 3) Enter the UE into loopback test mode and start the loopback test.

6.7.4.2 Procedure

- 1) Set the interfering signals as indicated in table 6.7.2.1 for the 3.84 Mcps TDD Option and table 6.7.2.2 for the 1.28 Mcps TDD Option)-with positive offset with respect to the wanted signal.
- 2) Measure the BER of DCH received from the UE at the SS.
- 3) Set the interfering signals as indicated in table 6.7.2.1 for the 3.84 Mcps TDD Option and table 6.7.2.2 for the 1.28 Mcps TDD Option -with negative offset with respect to the wanted signal and repeat 2).

6.7.5 Test requirements

6.7.5.1 3.84 Mcps TDD Option

The measured BER, derived in step 2) and 3), shall not exceed 0,001 under test conditions described in Table 6.7.5.1 for the 3.84 Mcps TDD Option.

Table 6.7.5.1: Test parameters Receive intermodulation characteristics (3.84 Mcps TDD Option)

Parameter	Value	Unit
$\frac{\Sigma DPCH_Ec}{I_{or}}$	0	dB
\hat{I}_{or} Wanted Signal Level	<REFSENS> + 3 dB	dBm/3.84 MHz
$I_{ouw1}(CW)$	-46	dBm
$I_{ouw2}(\text{modulated})$	-46	dBm/3.84 MHz
$F_{uw1}(CW)$	±10	MHz
$F_{uw2}(\text{Modulated})$	±20	MHz

NOTE: If the above Test Requirement differs from the Minimum Requirement then the Test Tolerance applied for this test is non-zero. The Test Tolerance for this test is defined in Annex F.2 and the explanation of how the Minimum Requirement has been relaxed by the Test Tolerance is given in Annex F.4.

6.7.5.2 1.28 Mcps TDD Option

The measured BER, derived in step 2) and 3), shall not exceed 0,001 under test conditions described in Table 6.7.5.2 for the 1.28 Mcps TDD Option.

Table 6.7.5.2: Test parameters Receive intermodulation characteristics (1.28 Mcps TDD Option)

Parameter	Level	Unit
$\frac{\Sigma DPCH_Ec}{I_{or}}$	0	dB
\hat{I}_{or}	[<REFSENS> + 3 dB]	dBm/1.28 MHz
$I_{ouw1}(CW)$	[-46]	dBm
$I_{ouw2}(\text{modulated})$	[-46]	dBm/1.28 MHz
$F_{uw1}(CW)$	[3.2]	MHz
$F_{uw2}(\text{Modulated})$	[6.4]	MHz

NOTE: If the above Test Requirement differs from the Minimum Requirement then the Test Tolerance applied for this test is non-zero. The Test Tolerance for this test is defined in Annex F.2 and the explanation of how the Minimum Requirement has been relaxed by the Test Tolerance is given in Annex F.4.

6.8 Spurious Emissions

6.8.1 Definition and applicability

The Spurious Emissions Power is the power of emissions generated or amplified in a receiver that appear at the UE antenna connector.

The requirements of this test are applicable for all UTRA UE.

6.8.2 Minimum Requirements

6.8.2.1 3.84 Mcps TDD Option

The power of any spurious emission shall not exceed:

Table 6.8.2.1: Receiver spurious emission requirements (3.84 Mcps TDD Option)

Band	Maximum level	Measurement Bandwidth	Note
9 kHz – 1 GHz	-57 dBm	100 kHz	
1 GHz – 1.9 GHz and 1.92 GHz – 2.01 GHz and 2.025 GHz – 2.11 GHz	-47 dBm	1 MHz	With the exception of frequencies between 12.5MHz below the first carrier frequency and 12.5MHz above the last carrier frequency used by the UE.
1.9 GHz – 1.92 GHz and 2.01 GHz – 2.025 GHz and 2.11 GHz – 2.170 GHz	-60 dBm	3.84 MHz	With the exception of frequencies between 12.5MHz below the first carrier frequency and 12.5MHz above the last carrier frequency used by the UE.
2.170 GHz – 12.75 GHz	-47 dBm	1 MHz	

The normative reference for this requirement is TS 25.102 [1] subclause 7.9.1.1.

6.8.2.2 1.28 Mcps TDD Option

The power of any spurious emission shall not exceed:

Table 6.8.2.2: Receiver spurious emission requirements(1.28Mcps TDD Option)

<u>Band</u>	<u>Maximum level</u>	<u>Measurement Bandwidth</u>	<u>Note</u>
<u>9 kHz – 1 GHz</u>	<u>-57 dBm</u>	<u>100 kHz</u>	
<u>1 GHz – 1.9 GHz and 1.92 GHz – 2.01 GHz and 2.025 GHz – 2.11 GHz</u>	<u>-47 dBm</u>	<u>1 MHz</u>	<u>With the exception of frequencies between 4MHz below the first carrier frequency and 4MHz above the last carrier frequency used by the UE.</u>
<u>1.9 GHz – 1.92 GHz and 2.01 GHz – 2.025 GHz and 2.11 GHz – 2.170 GHz</u>	<u>-64 dBm</u>	<u>1.28 MHz</u>	<u>With the exception of frequencies between 4MHz below the first carrier frequency and 4MHz above the last carrier frequency used by the UE.</u>

2.170 GHz – 12.75 GHz	-47 dBm	1 MHz	
---------------------------------------	-------------------------	-----------------------	--

[The normative reference for this requirement is TS 25.102 \[1\] subclause 7.9.1.2.](#)

6.8.3 Test purpose

The test purpose is to verify the UE's ability to limit interference caused by receiver spurious emissions to the own and the other systems. The test requirements are tighter than in 5.5.3 ((TX) Spurious Emissions) because the time of Receive-Only-Operation is generally much longer than RX-TX-Operation.

6.8.4 Method of test

6.8.4.1 Initial conditions

- 1) Connect the measurement equipment to the UE antenna connector according to figure A.8.
- 2) The measurement equipment shall measure power through
 - a 100 kHz filter with a approximately gaussian filter-characteristic (typical spectrum analyzer), or
 - a 1MHz filter with a approximately gaussian filter-characteristic (typical spectrum analyzer), or
 - a matched filter with a bandwidth equal to the chip frequency 3.84 Mchip/s [for the 3.84 Mcps TDD Option and 1.28 Mchips/s for the 1.28 Mcps TDD Option, respectively.](#) and rolloff 0.22.
- 3) Enable the UE receiver and set Cell Search Mode on a PCCPCH. Since there is no down link signal, the UE should not pass the Cell Search mode.

<Editor's Note: The method to set Cell Search Mode should be defined.>

6.8.4.2 Procedure

Measure the power of spurious emissions by covering the frequency ranges of table 6.8.2.1 [for the 3.84 Mcps TDD Option and table 6.8.2.2 for the 1.28 Mcps TDD Option, respectively.](#) Cover the UTRA/TDD and UTRA/FDD UE receive band in contiguous steps of [200 kHz]. Cover the other frequency ranges in contiguous steps of 100 kHz. Apply the corresponding filters of table 6.8.2.1 [for the 3.84 Mcps TDD Option and table 6.8.2.2 for the 1.28 Mcps TDD Option, respectively.](#) The step duration shall be sufficient slow to capture intermittent spurious emissions.

6.8.5 Test requirements

[6.8.5.1 3.84 Mcps TDD Option](#)

The spurious emissions shall be according to table 6.8.5.1 [for the 3.84 Mcps TDD Option.](#)

Table 6.8.5.1: Receiver spurious emission test requirements (3.84 Mcps TDD Option)

Band	Maximum level	Measurement Bandwidth	Note
9 kHz – 1 GHz	-57 dBm	100 kHz	
1 GHz – 1.9 GHz and 1.92 GHz – 2.01 GHz and 2.025 GHz – 2.11 GHz	-47 dBm	1 MHz	With the exception of frequencies between 12.5MHz below the first carrier frequency and 12.5MHz above the last carrier frequency used by the UE.
1.9 GHz – 1.92 GHz and 2.01 GHz – 2.025 GHz and 2.11 GHz – 2.170 GHz	-60 dBm	3.84 MHz	With the exception of frequencies between 12.5MHz below the first carrier frequency and 12.5MHz above the last carrier frequency used by the UE.
2.170 GHz – 12.75 GHz	-47 dBm	1MHz	

NOTE: If the above Test Requirement differs from the Minimum Requirement then the Test Tolerance applied for this test is non-zero. The Test Tolerance for this test is defined in Annex F.2 and the explanation of how the Minimum Requirement has been relaxed by the Test Tolerance is given in Annex F.4.

6.8.5.2 1.28 Mcps TDD Option

The spurious emissions shall be according to table 6.8.5.2 for the 1.28 Mcps TDD Option.

Table 6.8.5.2: Receiver spurious emission requirements(1.28Mcps TDD Option)

<u>Band</u>	<u>Maximum level</u>	<u>Measurement Bandwidth</u>	<u>Note</u>
<u>9 kHz – 1 GHz</u>	<u>[-57 dBm]</u>	<u>100 kHz</u>	
<u>1 GHz – 1.9 GHz and 1.92 GHz – 2.01 GHz and 2.025 GHz – 2.11 GHz</u>	<u>[-47 dBm]</u>	<u>1 MHz</u>	<u>With the exception of frequencies between 4MHz below the first carrier frequency and 4MHz above the last carrier frequency used by the UE.</u>
<u>1.9 GHz – 1.92 GHz and 2.01 GHz – 2.025 GHz and 2.11 GHz – 2.170 GHz</u>	<u>[-64 dBm]</u>	<u>1.28 MHz</u>	<u>With the exception of frequencies between 4MHz below the first carrier frequency and 4MHz above the last carrier frequency used by the UE.</u>
<u>2.170 GHz – 12.75 GHz</u>	<u>[-47 dBm]</u>	<u>1 MHz</u>	

NOTE: If the above Test Requirement differs from the Minimum Requirement then the Test Tolerance applied for this test is non-zero. The Test Tolerance for this test is defined in Annex F.2 and the explanation of how the Minimum Requirement has been relaxed by the Test Tolerance is given in Annex F.4.

7 Performance Requirements

7.1 General

The performance requirements for the UE in this section is specified for the measurement channels specified in annex C and the test environments specified in annex D.

7.2 Demodulation in static propagation conditions

7.2.1 Demodulation of DCH

7.2.1.1 Definition and applicability

The performance requirement of DCH in static propagation conditions is determined by the maximum Block Error Ratio (BLER). The BLER is specified for each individual data rate of the DCH. DCH is mapped into the Dedicated Physical Channel (DPCH).

The UE shall be tested only according to the datarates, supported. The data-rate-corresponding requirements shall apply to the UE.

7.2.1.2 ~~Conformance~~ Minimum requirements

7.2.1.2.1 3.84 Mcps TDD Option

For the parameters specified in table 7.2.1.2.1a the BLER shall not exceed the piece-wise linear BLER curve specified in table 7.2.1.2.1b. . These requirements are applicable for TFCS size 16.

The reference for this requirement is 3G TS 25.102 clause 8.2.1.1.1.

Table 7.2.1.2.1a: DCH parameters in static propagation conditions(3.84 Mcps TDD Option)

Parameters	Unit	Test 1Unit	Test 2Test 4	Test 3Test 2	Test 4Test 3	Test 54
$\frac{\Sigma DPCH _ E_c}{I_{or}}$	dB	-6dB	-3-6	0-3	00	0
I_{oc}	dBm/3.84 MHz	dBm/3.84 MHz	-60-60			
Information Data Rate	kbps	12.2kbps	6412.2	14464	384144	2048384

Table 7.2.1.2.1b: Performance requirements in AWGN channel(3.84 Mcps TDD Option)

Test Number	$\frac{\hat{I}_{or}}{I_{oc}}$ [dB]	BLER
1	0.1	10^{-2}
2	2.3	10^{-1}
	2.6	10^{-2}
3	2.2	10^{-1}
	2.4	10^{-2}
4	1.6	10^{-1}
	1.8	10^{-2}
<u>5</u>	<u>3.5</u>	<u>10^{-1}</u>
	<u>3.6</u>	<u>10^{-2}</u>

7.2.1.2.2 1.28 Mcps TDD Option

For the parameters specified in Table 7.2.1.2.2a the BLER should not exceed the piece-wise linear BLER curve specified in Table 7.2.1.2.2b.

Table 7.2.1.2.2a: DCH parameters in static propagation conditions(1.28Mcps TDD Option)

Parameters	Unit	Test 1	Test 2	Test 3	Test 4
Number of DPCH _o		<u>8</u>	<u>2</u>	<u>2</u>	<u>0</u>
$\frac{DPCH_o - E_c}{I_{or}}$	dB	<u>-10</u>	<u>-10</u>	<u>-10</u>	<u>0</u>
I_{oc}	DBm/1.28MHz	<u>-60</u>			
Information Data Rate	Kbps	<u>12.2</u>	<u>64</u>	<u>144</u>	<u>384</u>

Table 7.2.1.2.2b: Performance requirements in AWGN channel(1.28Mcps TDD Option)

Test Number	$\frac{\hat{I}_{or}}{I_{oc}}$ [dB]	BLER
<u>1</u>	<u>3.1</u>	<u>10^{-2}</u>
<u>2</u>	<u>2.1</u>	<u>10^{-1}</u>
	<u>2.4</u>	<u>10^{-2}</u>
<u>3</u>	<u>2.5</u>	<u>10^{-1}</u>
	<u>2.8</u>	<u>10^{-2}</u>
<u>4</u>	<u>2.8</u>	<u>10^{-1}</u>

7.2.1.3 Test purpose

While the receiver tests in clause 6 aims for the RF hardware, this performance requirement aims for the receiver's signal processing.

The test purpose is to verify the ability of the receiver to receive a predefined test signal, representing a static propagation channel for the wanted and for the co-channel signals from serving and adjacent cells, with a block error ratio (BLER) not exceeding a specified value.

7.2.1.4 Method of test

7.2.1.4.1 Initial conditions

- 1) Connect the SS, AWGN Generator and additional components to the UE antenna connector as shown in Figure A.9.
- 2) A call is set up according to the Generic call setup procedure. The characteristic of the call shall be according to the DL reference measurement channels (12.2 kbit/s) (64 kbit/s), (144 kbit/s), and (384 kbit/s) specified in annex C.
- 3) Enter the UE into loopback test mode and start the loopback test. (test 1) and/or activate the Ack/Nack test mode (test 1 to test 4).
- 4) The levels of the wanted signal and the co-channel signals are set according to table 7.2.1.2.1a and b. [for the 3.84 Mcps TDD Option and table 7.2.1.2.2a and b for the 1.28 Mcps TDD Option, respectively.](#)

7.2.1.4.2 Procedure

Measure the BLER of DCH received from the UE at the SS for all 4-tests [specified in table 7.2.1.2.1a for the 3.84 Mcps TDD Option and table 7.2.1.2.2a for the 1.28 Mcps TDD Option, respectively.](#)

7.2.1.5 Test requirements

The measured BLER shall not exceed the values indicated in table 7.2.1.2.1b. [for the 3.84 Mcps TDD Option and table 7.2.1.2.2b for the 1.28 Mcps TDD Option, respectively.](#)

7.3 Demodulation of DCH in multipath fading conditions

7.3.1 Multipath fading Case 1

7.3.1.1 Definition and applicability

The performance requirement of DCH is determined by the maximum Block Error Ratio (BLER). The BLER is specified for each individual data ratio of the DCH. DCH is mapped into the Dedicated Physical Channel (DPCH).

The UE shall be tested only according to the data ratios, supported. The data-ratio-corresponding requirements shall apply to the UE.

7.3.1.2 ~~Conformance~~Minimum requirements

7.3.1.2.1 3.84 Mcps TDD Option

For the parameters specified in table 7.3.1.2.1a the BLER shall not exceed the piece-wise linear BLER curve specified in table 7.3.1.2.1b. . These requirements are applicable for TFCS size 16.

The reference for this requirement is 3G TS 25.102 clause 8.3.1.1.1.

Table 7.3.1.2.1a: DCH parameters in multipath Case 1 channel(3.84 Mcps TDD Option)

Parameters	Unit	Test 1	Test 2	Test 3	Test 4	Test 5
$\frac{\Sigma DPCH - E_c}{I_{or}}$	DB	-6	-3	0	0	0
I_{oc}	dBm/3.84 MHz	-60				
Information Data Rate	kbps	12.2	64	144	384	2048

Parameters	Unit	Test 1	Test 2	Test 3	Test 4
$\frac{\Sigma DPCH - E_c}{I_{or}}$	dB	-6	-3	0	0
I_{oc}	dBm/3.84 MHz	-60			
Information Data Rate	kbps	12.2	64	144	384

Table 7.3.1.2.1b: Performance requirements in multipath Case 1 channel(3.84 Mcps TDD Option)

Test Number	$\frac{\hat{I}_{or}}{I_{oc}}$ [dB]	BLER
1	13.5	10^{-2}
2	13.3	10^{-1}
	19.6	10^{-2}
3	13.3	10^{-1}
	19.7	10^{-2}
4	13.5	10^{-1}
	20.2	10^{-2}
5	13.2	10^{-1}
	17.8	10^{-2}

7.3.1.2.2 1.28 Mcps TDD Option

For the parameters specified in Table 7.3.1.2.2a the BLER should not exceed the piece-wise linear BLER curve specified in Table 7.3.1.2.2b.

Table 7.3.1.2.2a: DCH parameters in static propagation conditions(1.28Mcps TDD Option)

Parameters	Unit	Test 1	Test 2	Test 3	Test 4
Number of DPCH _o		8	2	2	0
$\frac{DPCH_o - E_c}{I_{or}}$	dB	-10	-10	-10	0

I_{oc}	DBm/1.28MHz	-60			
Information Data Rate	Kbps	12.2	64	144	384

Table 7.3.1.2.2b: Performance requirements in AWGN channel(1.28Mcps TDD Option)

Test Number	$\frac{\hat{I}_{or}}{I_{oc}}$ [dB]	BLER
1	3.1	10^{-2}
2	2.1	10^{-1}
	2.4	10^{-2}
3	2.5	10^{-1}
	2.8	10^{-2}
4	2.8	10^{-1}

7.3.1.3 Test purpose

While the receiver tests in clause 6 aims for the RF hardware, this performance requirement aims for the receiver's signal processing.

The test purpose is to verify the ability of the receiver to receive a predefined test signal, representing a multipath propagation channel for the wanted and for the co-channel signals from serving and adjacent cells, with a block error ratio (BLER) not exceeding a specified value.

7.3.1.4 Method of test

7.3.1.4.1 Initial conditions

- 1) Connect the SS, , the fading simulator, the AWGN generator and additional components to the UE antenna connector as shown in Figure A.10.
- 2) A call is set up according to the Generic call setup procedure. The characteristic of the call shall be according to the DL reference measurement channels (12.2 kbit/s), (64 kbit/s), (144 kbit/s), and (384 kbit/s) specified in annex C.
- 3) Enter the UE into loopback test mode and start the loopback test. (test 1) and/or activate the Ack/Nack test mode (test 1 to test 4).
- 4) The levels of the wanted signal and the co-channel signals are set according to table 7.3.1.2.1a and b. for the 3.84 Mcps TDD Option and table 7.3.1.2.2a and b for the 1.28 Mcps TDD Option, respectively.

7.3.1.4.2 Procedure

Measure the BLER of DCH received from the UE at the SS for all 4-tests specified in table 7.3.1.2.1a for the 3.84 Mcps TDD Option and table 7.3.1.2.2a for the 1.28 Mcps TDD Option, respectively.

7.3.1.5 Test requirements

The measured BLER shall not exceed the values indicated in table 7.3.1.2.1b. [for the 3.84 Mcps TDD Option and table 7.3.1.2.2b for the 1.28 Mcps TDD Option, respectively.](#)

7.3.2 Multipath fading Case 2

7.3.2.1 Definition and applicability

The performance requirement of DCH is determined by the maximum Block Error Ratio (BLER). The BLER is specified for each individual data rate of the DCH. DCH is mapped into the Dedicated Physical Channel (DPCH).

The UE shall be tested only according to the datarates, supported. The data-rate-corresponding requirements shall apply to the UE.

7.3.2.2 ~~Conformance~~Minimum requirement

[7.3.2.2.1 3.84 Mcps TDD Option](#)

For the parameters specified in table 7.3.2.2.1a the BLER should not exceed the piece-wise linear BLER curve specified in table 7.3.2.2.1b. . These requirements are applicable for TFCS size 16.

The reference for this requirement is 3G TS 25.102 clause 8.3.2.1

Table 7.3.2.2.1a: DCH parameters in multipath Case 2 channel(3.84 Mcps TDD Option)

Parameters	Unit	Test 1	Test 2	Test 3	Test 4	Test 5
$\frac{\Sigma DPCH - E_c}{I_{or}}$	DB	-3	0	0	0	0
I_{oc}	dBm/3.84 MHz	-60				
Information Data Rate	kbps	12.2	64	144	384	2048

Parameters	Unit	Test 1	Test 2	Test 3	Test 4
$\frac{\Sigma DPCH - E_c}{I_{or}}$	DB	-3	0	0	0
I_{oc}	dBm/3.84 MHz	-60			
Information Data Rate	kbps	12.2	64	144	384

Table 7.3.2.2.1b: Performance requirements in multipath Case 2 channel(3.84 Mcps TDD Option)

Test Number	$\frac{\hat{I}_{or}}{I_{oc}}$ [dB]	BLER
1	5.5	10^{-2}
2	5.8	10^{-1}
	9.7	10^{-2}
3	9.5	10^{-1}
	13.2	10^{-2}
4	8.5	10^{-1}
	12.6	10^{-2}
<u>5</u>	<u>10.3</u>	<u>10^{-1}</u>
	<u>12.7</u>	<u>10^{-2}</u>

7.3.2.2.2 1.28 Mcps TDD Option

For the parameters specified in Table 7.3.2.2.2a: the BLER should not exceed the piece-wise linear BLER curve specified in Table 7.3.2.2.2b.

Table 7.3.2.2.2a: DCH parameters in multipath Case 2 channel(1.28Mcps TDD Option)

Parameters	Unit	Test 1	Test 2	Test 3	Test 4
Number of DPCH _o		<u>8</u>	<u>2</u>	<u>2</u>	<u>0</u>
$\frac{DPCH_o - E_c}{I_{or}}$	dB	<u>-10</u>	<u>-10</u>	<u>-10</u>	<u>0</u>
I_{oc}	dBm/1.28MHz	<u>-60</u>			
Information Data Rate	Kbps	<u>12.2</u>	<u>64</u>	<u>144</u>	<u>384</u>

Table 7.3.2.2.2b: Performance requirements in multipath Case 2 channel(1.28Mcps TDD Option)

Test Number	$\frac{\hat{I}_{or}}{I_{oc}}$ [dB]	BLER
<u>1</u>	<u>13.2</u>	<u>10^{-2}</u>
<u>2</u>	<u>9.5</u>	<u>10^{-1}</u>
	<u>13.7</u>	<u>10^{-2}</u>
<u>3</u>	<u>10.0</u>	<u>10^{-1}</u>
	<u>14.0</u>	<u>10^{-2}</u>
<u>4</u>	<u>10.0</u>	<u>10^{-1}</u>
	<u>14.0</u>	<u>10^{-2}</u>

7.3.2.3 Test purpose

While the receiver tests in clause 6 aims for the RF hardware, this performance requirement aims for the receiver's signal processing.

The test purpose is to verify the ability of the receiver to receive a predefined test signal, representing a multipath propagation channel for the wanted and for the co-channel signals from serving and adjacent cells, with a block error ratio (BLER) not exceeding a specified value.

7.3.2.4 Method of test

7.3.2.4.1 Initial conditions

- 1) Connect the SS, the fading simulator, the AWGN generator and additional components to the UE antenna connector as shown in Figure A.10.
- 2) A call is set up according to the Generic call setup procedure. The characteristic of the call shall be according to the DL reference measurement channels (12.2 kbit/s) (64 kbit/s), (144 kbit/s), and (384 kbit/s) specified in annex C.
- 3) Enter the UE into loopback test mode and start the loopback test. (test 1) and/or activate the Ack/Nack test mode (test 1 to test 4).
- 4) The levels of the wanted signal and the co-channel signals are set according to table 7.3.2.2.1a and b. [for the 3.84 Mcps TDD Option and table 7.3.2.2.2a and b for the 1.28 Mcps TDD Option, respectively.](#)

7.3.2.4.2 Procedure

Measure the BLER of DCH received from the UE at the SS for all 4-tests [specified in table 7.3.2.2.1a for the 3.84 Mcps TDD Option and table 7.3.2.2.2a for the 1.28 Mcps TDD Option, respectively.](#)

7.3.2.5 Test requirements

The measured BLER shall not exceed the values indicated in table 7.3.2.2.1.b- [for the 3.84 Mcps TDD Option and table 7.3.2.2.2b for the 1.28 Mcps TDD Option, respectively.](#)

7.3.3 Multipath fading Case 3

7.3.3.1 Definition and applicability

The performance requirement of DCH is determined by the maximum Block Error Ratio (BLER). The BLER is specified for each individual data rate of the DCH. DCH is mapped into the Dedicated Physical Channel (DPCH).

The UE shall be tested only according to the data rates, supported. The data-rate-corresponding requirements shall apply to the UE.

7.3.3.2 ~~Conformance~~Minimum requirements

7.3.3.2.1 3.84 Mcps TDD Option

For the parameters specified in table 7.3.3.2.1a the BLER should not exceed the piece-wise linear BLER curve specified in table 7.3.3.2.1b. . These requirements are applicable for TFCS size 16.

The reference for this requirement is 3G TS 25.102 clause 8.3.3.1.1.

Table 7.3.3.2.1a: DCH parameters in multipath Case 3 channel(3.84 Mcps TDD Option)

Parameters	Unit	Test 1	Test 2	Test 3	Test 4	Test 5
$\frac{\Sigma DPCH - E_c}{I_{or}}$	DB	-3	0	0	0	0
I_{oc}	dBm/3.84 MHz	-60				
Information Data Rate	kbps	12.2	64	144	384	2048

Parameters	Unit	Test 1	Test 2	Test 3	Test 4
$\frac{\Sigma DPCH - E_c}{I_{or}}$	dB	-3	0	0	0
I_{oc}	dBm/3.84 MHz	-60			
Information Data Rate	kbps	12.2	64	144	384

Table 7.3.3.2.1b: Performance requirements in multipath Case 3 channel(3.84 Mcps TDD Option)

Test Number	$\frac{\hat{I}_{or}}{I_{oc}}$ [dB]	BLER
1	4.7	10^{-2}
2	5.2	10^{-1}
	8.4	10^{-2}
	12.1	10^{-3}
3	11.7	10^{-1}
	15.2	10^{-2}
	17.8	10^{-3}
4	8.2	10^{-1}
	11.3	10^{-2}
	13.0	10^{-3}
5	9.4	10^{-1}
	11.5	10^{-2}
	13.6	10^{-3}

Test Number	$\frac{\hat{I}_{or}}{I_{oc}}$ [dB]	BLER
12.2 kbps	4.7	10^{-2}
64 kbps	5.2	10^{-1}
	8.4	10^{-2}
	12.1	10^{-3}
144 kbps	11.7	10^{-1}
	15.2	10^{-2}
	17.8	10^{-3}
384 kbps	8.2	10^{-1}
	11.3	10^{-2}
	13.0	10^{-3}

7.3.3.2.2 1.28 Mcps TDD Option

For the parameters specified in Table 7.3.3.2.2a the BLER should not exceed the piece-wise linear BLER curve specified in Table 7.3.3.2.2b.

Table 7.3.3.2.2a: DCH parameters in multipath Case 3 channel(1.28Mcps TDD Option)

Parameters	Unit	Test 1	Test 2	Test 3	Test 4
Number of DPCH _o		8	2	2	0
$\frac{DPCH_o - E_c}{I_{or}}$	dB	-10	-10	-10	0
I _{oc}	dBm/1.28MHz	-60			
Information Data Rate	Kbps	12.2	64	144	384

Table 7.3.3.2.2b: Performance requirements in multipath Case 3 channel(1.28Mcps TDD Option)

Test Number	$\frac{\hat{I}_{or}}{I_{oc}}$ [dB]	BLER
1	10.8	10^{-2}
2	8.3	10^{-1}
	11.1	10^{-2}
	13.8	10^{-3}
3	8.7	10^{-1}
	10.6	10^{-2}
	11.8	10^{-3}
4	8.8	10^{-1}
	10.3	10^{-2}
	11.5	10^{-3}

7.3.3.3 Test purpose

While the receiver tests in clause 6 aims for the RF hardware, this performance requirement aims for the receiver's signal processing.

The test purpose is to verify the ability of the receiver to receive a predefined test signal ,representing a multipath propagation channel for the wanted and for the co-channel signals from serving and adjacent cells, with a block error ratio (BLER) not exceeding a specified value.

7.3.3.4 Method of test

7.3.3.4.1 Initial conditions

- 1) Connect the SS, the fading simulator, the AWGN generator and additional components to the UE antenna connector as shown in Figure A.10.
- 2) A call is set up according to the Generic call setup procedure. The characteristic of the call shall be according to the DL reference measurement channels (12.2 kbit/s)(64 kbit/s), (144 kbit/s), and (384 kbit/s) specified in annex C.
- 3) Enter the UE into loopback test mode and start the loopback test. (test 1) and/or activate the Ack/Nack test mode (test 1 to test 4).
- 4) The levels of the wanted signal and the co-channel signals are set according to table 7.3.3.2.1.a and b-[for the 3.84 Mcps TDD Option and table 7.3.3.2.2a and b for the 1.28 Mcps TDD Option, respectively.](#)

7.3.3.4.2 Procedure

Measure the BLER of DCH received from the UE at the SS for all 4-tests [specified in table 7.3.3.2.1a for the 3.84 Mcps TDD Option and table 7.3.3.2.2a for the 1.28 Mcps TDD Option, respectively.](#) .

7.3.3.5 Test requirements

The measured BLER shall not exceed the values indicated in table 7.3.3.2.1.b [for the 3.84 Mcps TDD Option and table 7.3.3.2.2b for the 1.28 Mcps TDD Option, respectively.](#)

7.4 Base station transmit diversity mode [for 3.84 Mcps TDD Option](#)

7.4.1 Demodulation of BCH in Block STTD mode

The performance requirement of BCH is determined by the maximum Block Error Rate (BLER). The BLER is specified for the BCH. BCH is mapped into the Primary Common Control Physical Channel (P-CCPCH).

7.4.1.1 [ConformanceMinimum](#) requirements

For the parameters specified in Table 7.4.1.1.a the BLER should not exceed the BLER specified in Table 7.4.1.1.b

The reference for this requirement is 3G TS 25.102 clause 8.4.1.

Table 7.4.1.1.a: P-CCPCH parameters in multipath Case 1 channel

Parameters	Unit	Test 1
$\frac{PCCPCH_E_c}{I_{or}}$	dB	-3
I	dBm/3.84 MHz	-60
Information Data Rate	Kbps	12.3

Table 7.4.1.1.b: Performance requirements in multipath Case 1 channel.

Test Number	$\frac{\hat{I}_{or}}{I_{oc}}$ [dB]	BLER
1	8.4	10^{-2}

7.5 Power control in downlink for 3.84 Mcps TDD Option

Power control in the downlink is the ability of the UE receiver to converge to the required link quality set by the network while using minimum downlink power.

7.5.1 ConformanceMinimum requirements

For the parameters specified in Table 7.5.1.a the average downlink \hat{I}_{or}/I_{oc} power shall not exceed the values specified in Table 7.5.1.b. Downlink power control is ON during the test.

Table 7.5.1.a: Test parameters for downlink power control

Parameter	Unit	Test 1	Test 2
$\frac{DPCH_E_c}{I_{or}}$	dB	0	[]
I_{oc}	dBm/3.84 MHz	-60	
Information Data Rate	kbps	12.2	
Target quality value on DTCH	BLER	0.01	
Propagation condition		Case 4	

Table 7.5.1.b: Requirements for downlink power control

Parameter	Unit	Test 1	Test 2
\hat{I}_{or}/I_{oc}	dB	[]	[]
Measured quality on DTCH	BLER	0.01±30%	0.01±30%

8 Requirements for Support of RRM

8.1 General

8.2 Idle Mode Tasks

8.2.1 Introduction

8.2.2 RF Cell Selection Scenario

8.2.2.1 Requirements for Cell Selection single carrier single cell case

8.2.2.2 Requirements for Cell Selection multicarrier carrier multi cell case

8.2.3 RF Cell Re-Selection Scenario

8.2.3.1 Requirements for Cell Re-Selection single carrier multi cell case

8.2.4 PLMN Selection and Re-Selection Scenario

8.2.5 Location Registration Scenario

8.3 RRC Connection mobility

8.3.1 Handover

8.3.1.1 Introduction

8.3.1.2 Handover 3G to 3G

8.3.1.2.1 TDD/TDD Handover

8.3.1.2.2 TDD/FDD Handover

8.3.1.3 Handover 3G to 2G

8.3.1.3.1 Handover to GSM

8.3.2 Radio Link Management

8.3.2.1 Link adaptation

8.3.3 Cell Update

8.3.4 URA Update

8.4 RRC Connection Control

8.4.1 Radio Access Bearer Control

8.5 Dynamic Channel Allocation

8.6 Timing characteristics

8.6.1 Timing Advance (TA) Requirements

8.7 Measurements Performance Requirements

8.7.1 Measurements Performance for UE

Annex A (informative): Connection Diagrams

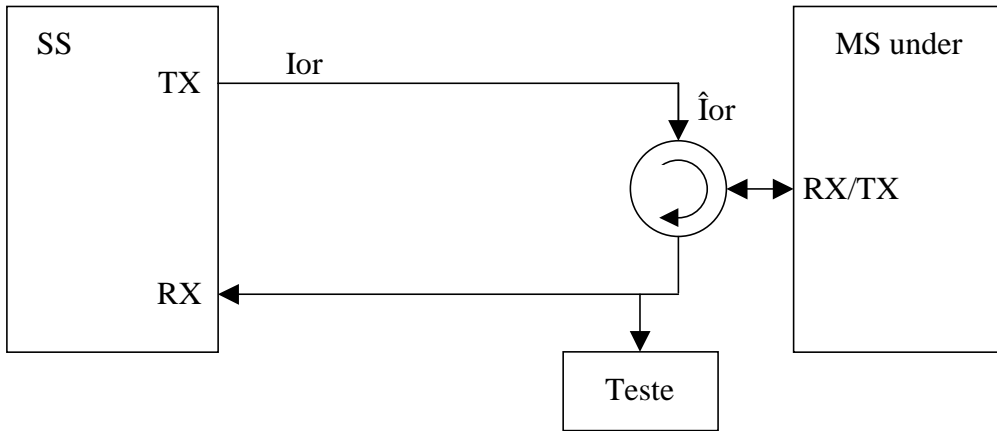

Figure A.1: Connection for Basic TX Test

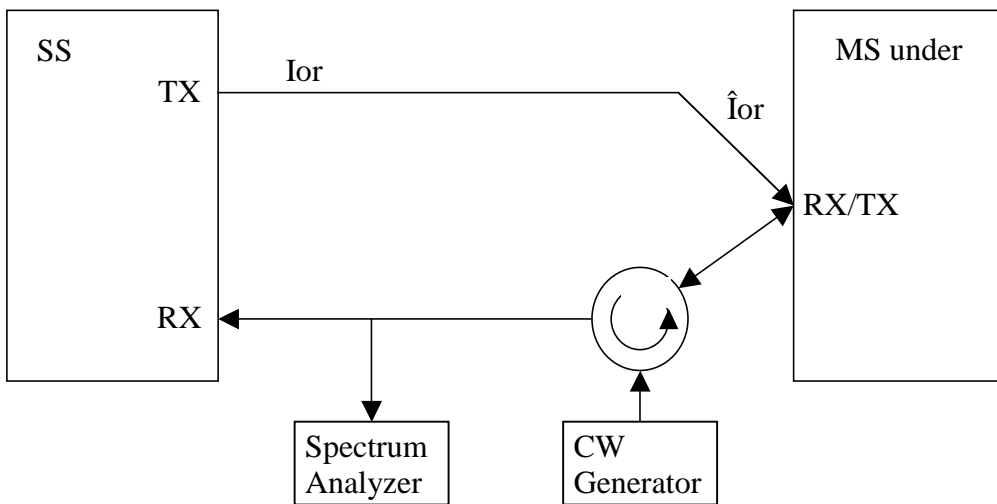

Figure A.2: Connection for TX Intermodulation Test

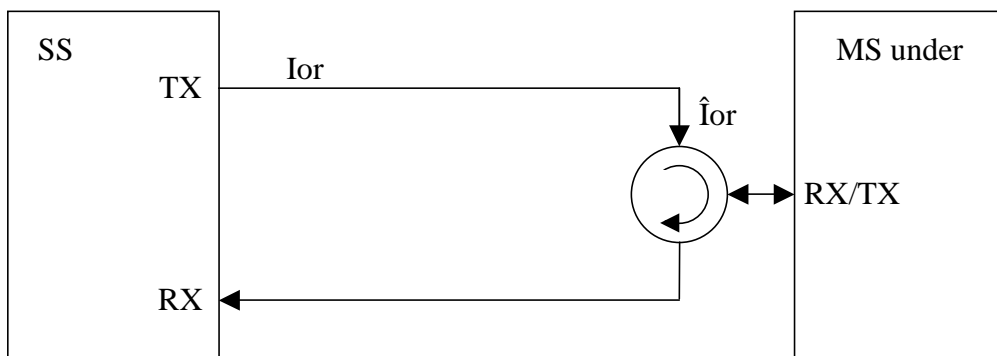

Figure A.3: Connection for Basic RX Test

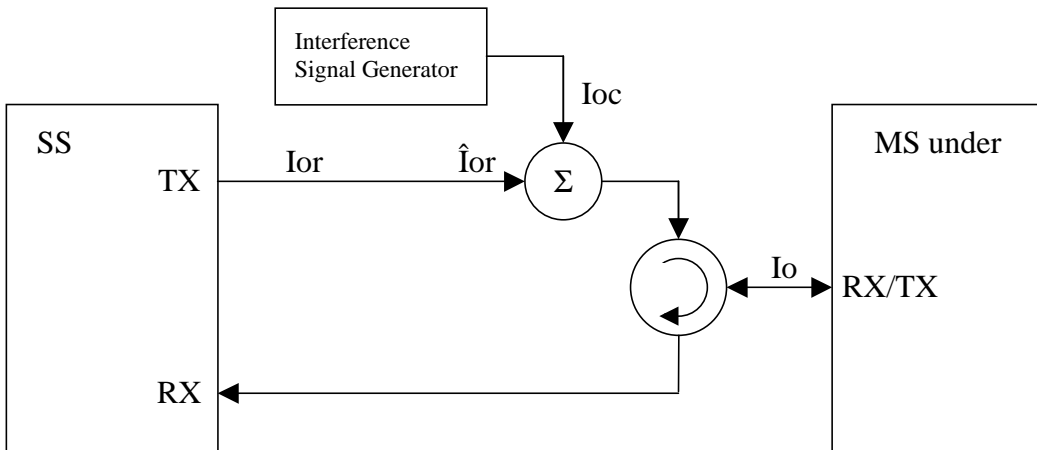

Figure A.4: Connection for RX Test with Interference

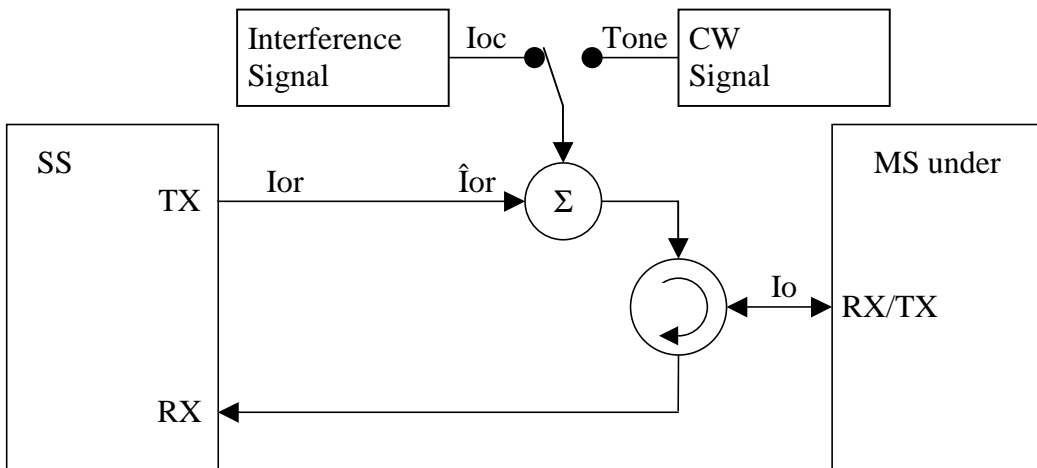

Figure A.5: Connection for RX Test with Interference or additional CW

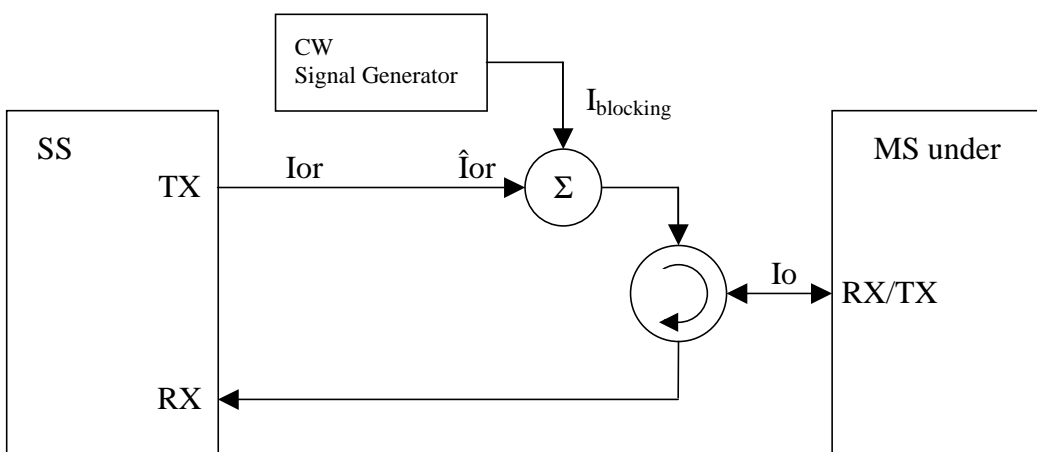

Figure A.6: Connection for RX Test with additional CW

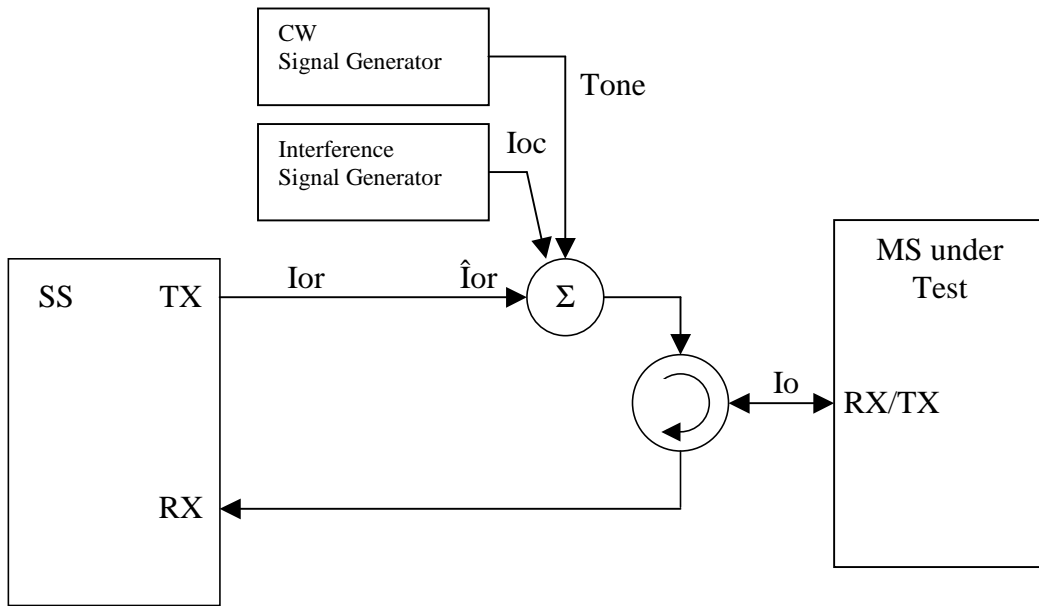

Figure A.7: Connection for RX Test with both Interference and additional CW



Figure A.8: Connection for Spurious Emission Test

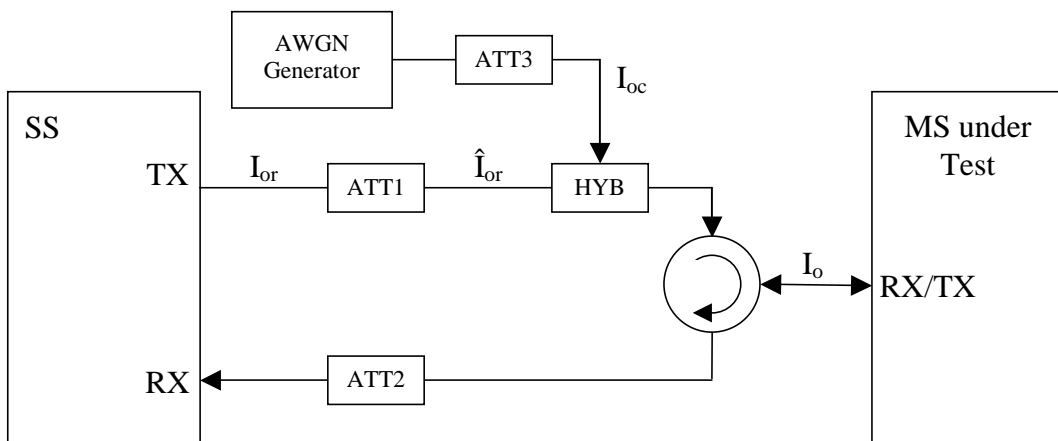

Figure A.9: Connection for Static Channel Test

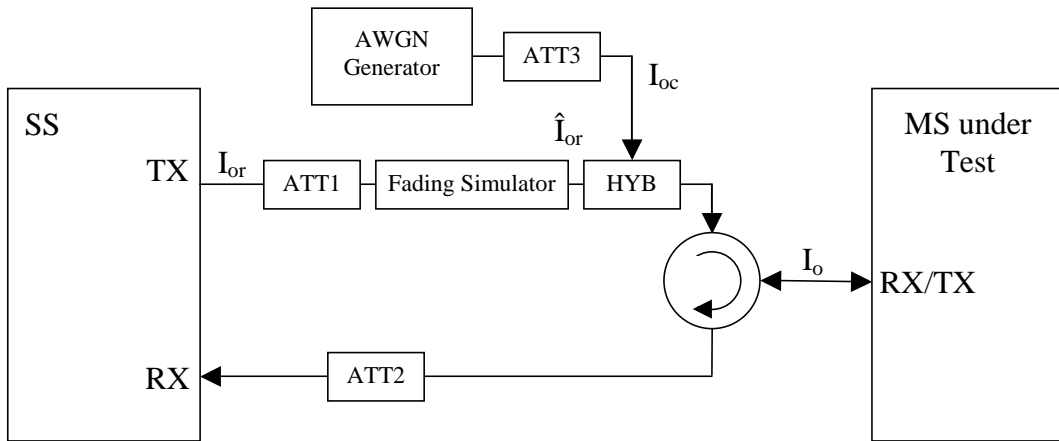

Figure A.10: Connection for Multiple Fading Channel Test

Annex B (normative): Global In-Channel TX-Test

B.1 General

The global in-channel Tx test enables the measurement of all relevant parameters that describe the in-channel quality of the output signal of the Tx under test in a single measurement process.

The parameters describing the in-channel quality of a transmitter, however, are not necessarily independent. The algorithm chosen for description inside this annex places particular emphasis on the exclusion of all interdependencies among the parameters. Any other algorithm (e.g. having better computational efficiency) may be applied, as long as the results are the same within the accuracy limits.

All notes referred in the various subclauses of B.2 are put together in B.3

B.2 Definition of the process

B.2.1 Basic principle

The process is based on the comparison of the actual **output signal of the TX under test**, received by an ideal receiver, with a **reference signal**, that is generated by the measuring equipment and represents an ideal error free received signal. All signals are represented as equivalent (generally complex) baseband signals.

B.2.2 Output signal of the TX under test

The output signal of the TX under test is acquired by the measuring equipment, filtered by a matched filter (RRC 0.22, correct in shape and in position on the frequency axis) and stored at one sample per chip at the Inter-Symbol-Interference free instants.

The following form represents the physical signal in the entire measurement interval:

one vector **Z**, containing $N = n_s \times sf + m_a$ complex samples;

with

n_s : number of symbols in the measurement interval;

sf : snumber of chips per symbol. (sf : spreading factor) (see Note: Symbol length)

m_a : number of midamble chips (only in TDD)

B.2.3 Reference signal

The reference signal is constructed by the measuring equipment according to the relevant TX specifications.

It is filtered by the same matched filter, mentioned in B.2.2., and stored at the Inter-Symbol-Interference free instants. The following form represents the reference signal in the entire measurement interval:

one vector **R**, containing $N = n_s \times sf + m_a$ complex samples;

n_s , sf , m_a : see B.2.2

B.2.4 void

B.2.5 Classification of measurement results

The measurement results achieved by the global in-channel TX test can be classified into two types:

Results of type “deviation”, where the error-free parameter has a non-zero magnitude. (These are the parameters that quantify the integral physical characteristic of the signal). These parameters are:

RF Frequency	
Power	(in case of single code)
Code Domain Power	(in case of multi code)
Timing	(only for UE)

(Additional parameters: see Note: Deviation)

Results of type “residual”, where the error-free parameter has value zero. (These are the parameters that quantify the error values of the measured signal, whose ideal magnitude is zero). These parameters are:

Error Vector Magnitude (EVM);
Peak Code Domain Error (PCDE).

(Additional parameters: see Note residual)

B.2.6 Process definition to achieve results of type “deviation”

The reference signal (**R**; see subclause B.2.3) is varied with respect to the parameters mentioned in subclause B.2.5 under "results of type deviation" in order to achieve best fit with the recorded signal under test (**Z**; see subclause B.2.2). Best fit is achieved when the RMS difference value between the signal under test and the varied reference signal is an absolute minimum. The varied reference signal, after the best fit process, will be called **R'**.

The varying parameters, leading to **R'** represent directly the wanted results of type “deviation”. These measurement parameters are expressed as deviation from the reference value with units same as the reference value.

In case of multi code, the type-“deviation”-parameters (frequency, timing and (RF-phase)) are varied commonly for all codes such that the process returns one frequency-deviation, one timing deviation, (one RF-phase –deviation).

(These parameters are not varied on the individual codes signals such that the process returns k frequency errors... . (k: number of codes)).

The only type-“deviation”-parameters varied individually are code powers such that the process returns k code power deviations (k: number of codes).

B.2.7 Process definition to achieve results of type "residual"

The difference between the varied reference signal (\mathbf{R}' ; see subclause B.2.6.) and the TX signal under test (\mathbf{Z} ; see subclause B.2.2) is the error vector \mathbf{E} versus time:

$$\mathbf{E} = \mathbf{Z} - \mathbf{R}'.$$

Depending on the parameter to be evaluated, it is appropriate to represent \mathbf{E} in one of the following two different forms:

Form EVM (representing the physical error signal in the entire measurement interval)

One vector \mathbf{E} , containing $N = n_s \times s_f + m_a$ complex samples;

n_s, s_f, m_a : see B.2.2

Form PCDE (derived from Form EVM by separating the samples into symbol intervals)

n_s time-sequential vectors \mathbf{e} with s_f complex samples comprising one symbol interval.

\mathbf{E} gives results of type "residual" applying the two algorithms defined in subclauses B 2.7.1 and B 2.7.2.

B.2.7.1 Error Vector Magnitude (EVM)

The Error Vector Magnitude EVM is calculated according to the following steps:

- 1) Take the error vector \mathbf{E} defined in subclause B.2.7 (Form EVM) and calculate the RMS value of \mathbf{E} ; the result will be called $\text{RMS}(\mathbf{E})$.
- 2) Take the varied reference vector \mathbf{R}' defined in subclause B.2.6 and calculate the RMS value of \mathbf{R}' ; the result will be called $\text{RMS}(\mathbf{R}')$.
- 3) Calculate EVM according to:

$$\text{EVM} = \frac{\text{RMS}(\mathbf{E})}{\text{RMS}(\mathbf{R}')} \times 100\% \quad (\text{here, EVM is relative and expressed in \%})$$

(see note TDD)

B.2.7.2 Peak Code Domain Error (PCDE)

The Peak Code Domain Error is calculated according to the following steps:

- 1) Take the error vectors \mathbf{e} defined in subclause B.2.7 (Form PCDE)
- 2) Take the orthogonal vectors of the channelisation - code set \mathbf{C} (all codes belonging to one spreading factor) as defined in TS 25.213 and TS 25.223 (range +1, -1). (see Note: Symbol length)
- 3) To achieve meaningful results it is necessary to descramble \mathbf{e} , leading to \mathbf{e}' (see Note1: Scrambling code)
- 4) Calculate the inner product of \mathbf{e}' with \mathbf{C} . Do this for all symbols of the measurement interval and for all codes in the code space.
This gives an array of format $k \times n_s$, each value representing an error-vector representing a specific symbol and a specific code, which can be exploited in a variety of ways.

k :	number of codes
n_s :	number of symbols in the measurement interval
- 5) Calculate k RMS values, each RMS value unifying n_s symbols within one code.
(These values can be called "*Absolute CodeEVMs*" [Volt].)
- 6) Find the peak value among the k "*Absolute CodeEVMs*".
(This value can be called "*Absolute PeakCodeEVM*" [Volt].)

7) Calculate PCDE according to:

$$10 \cdot \lg \frac{(\text{“Absolute PeakCodeEVM”})^2}{(\text{RMS}(\mathbf{R}'))^2} \quad \text{dB} \quad (\text{a relative value in dB}).$$

(see Note: Denominator)

(see Note2: Scrambling code)

(see Note IQ)

(see Note TDD)

(see Note Synch channel)

B.3 Notes

Note: Symbol length)

A general code multiplexed signal is multicode and multirate. In order to avoid unnecessary complexity, the measurement applications use a unique symbol-length, corresponding to a spreading factor, regardless of the really intended spreading factor. Nevertheless the complexity with a multicode / multirate signal can be mastered by introducing appropriate definitions.

Note: Deviation)

It is conceivable to regard more parameters as type „deviation“ e.g. Chip frequency and RF-phase.

As chip-frequency and RF-frequency are linked together by a statement in the core specifications [1] it is sufficient to process RF frequency only.

A parameter RF-phase must be varied within the best fit process (B 2.6.). Although necessary, this parameter-variation doesn't describe any error, as the modulation schemes used in the system don't depend on an absolute RF-phase.

Note: residual)

It is conceivable to regard more parameters as type „residual“ e.g. IQ origin offset. As it is not the intention of the test to separate for different error sources, but to quantify the quality of the signal, all such parameters are not extracted by the best fit process, instead remain part of EVM and PCDE.

Note: Denominator)

If the denominator stems from mutual time shifted signals of different code powers, (e.g. BS, FDD) the measurement result PCDE should be expressed absolutely instead.

Note1: Scrambling Code)

In general a TX signal under test can use more than one scrambling code. Note that PCDE is processed regarding the unused channelisation - codes as well. In order to know which scrambling code shall be applied on unused channelisation - codes, it is necessary to restrict the test conditions: TX signal under test shall use exactly one scrambling code.

Note2 Scrambling Code)

To interpret the measurement results in practice it should be kept in mind that erroneous code power on unused codes is generally de-scrambled differently under test conditions and under real life conditions, whereas erroneous code power on used codes is generally de-scrambled equally under test conditions and under real life conditions. It might be indicated if a used or unused code hits PCDE.

Note IQ)

As in FDD/uplink each code can be used twice, on the I and on the Q channel, the measurement result may indicate on which channel (I or Q) PCDE occurs.

Note TDD)

EVM covers the midamble part as well as the data part; however PCDE disregards the midamble part.

Note: Synch Channel)

A BS signal contains a physical synch channel, which is non orthogonal, related to the other DPCHs. In this context note: The code channel bearing the result of PCDE is exactly one of the DPCHs (never the synch channel). The origin of PCDE (erroneous code power) can be any DPCH and/or the synch channel.

Annex C (normative): Measurement channels

C.1 General

C.2 UL Reference measurement channels

C.2.1 UL reference measurement channel (12.2 kbps)

C.2.1.1 3.84 TDD Option

Parameter	
Information data rate	12.2 kbps
RU's allocated	2 RU
Midamble	512 chips
Interleaving	20 ms
Power control	2 Bit/user
TFCI	16 Bit/user
Inband signalling DCCH	2 kbps
Puncturing level at Code rate 1/3 : DCH / DCCH	5% / 0%

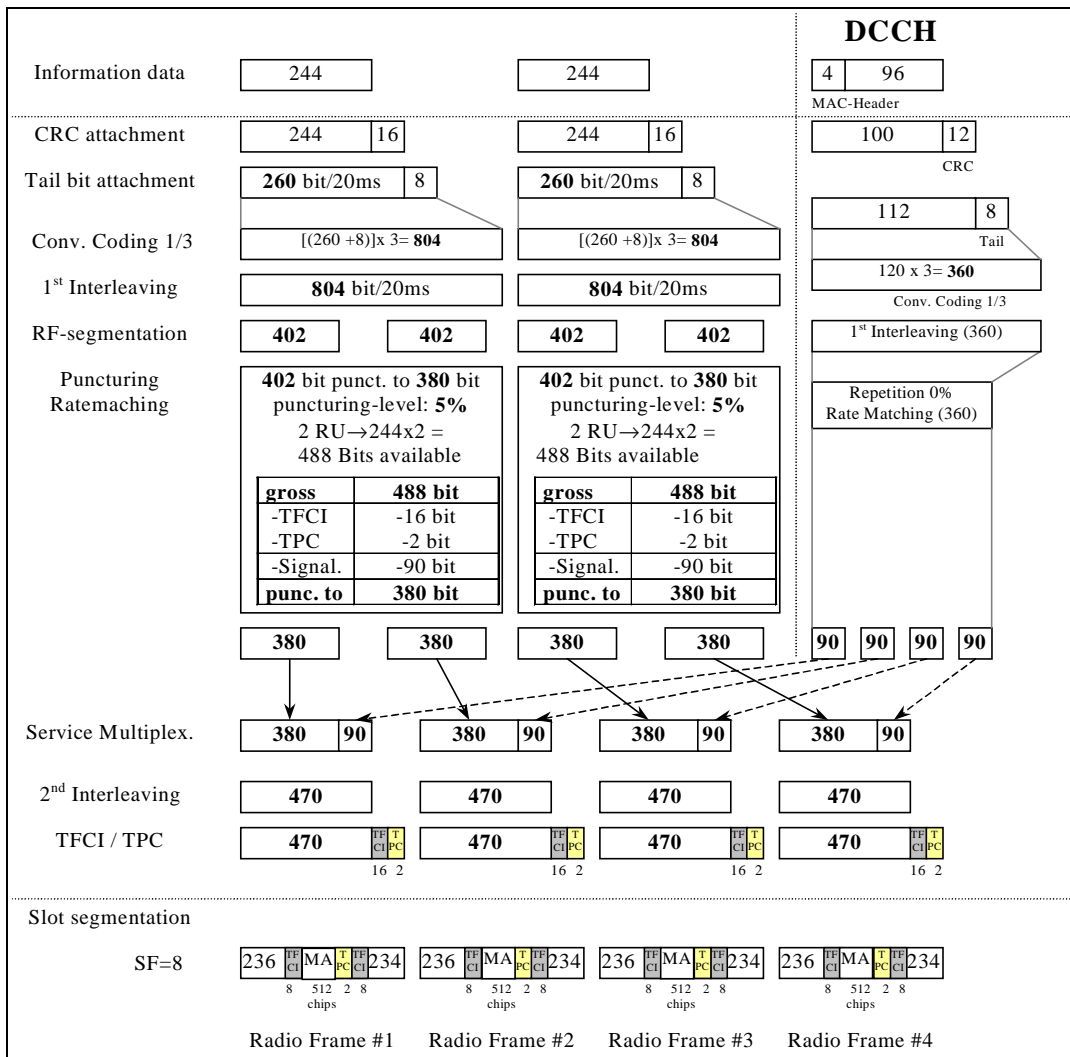

C.2.1.2 UL reference measurement channel (12.2 kbps) for 1.28 Mcps TDD Option

Parameter	
Information data rate	12.2 kbps
RU's allocated	1TS (1*SF8) = 2RU/5ms
Midamble	144

<u>Interleaving</u>	<u>20 ms</u>
<u>Power control (TPC)</u>	<u>4 Bit/user/10ms</u>
<u>TFCI</u>	<u>16 Bit/user/10ms</u>
<u>Synchronisation Shift (SS)</u>	<u>4 Bit/user/10ms</u>
<u>Inband signalling DCCH</u>	<u>2 kbps</u>
<u>Puncturing level at Code rate 1/3: DCH / DCCH</u>	<u>33% / 33%</u>

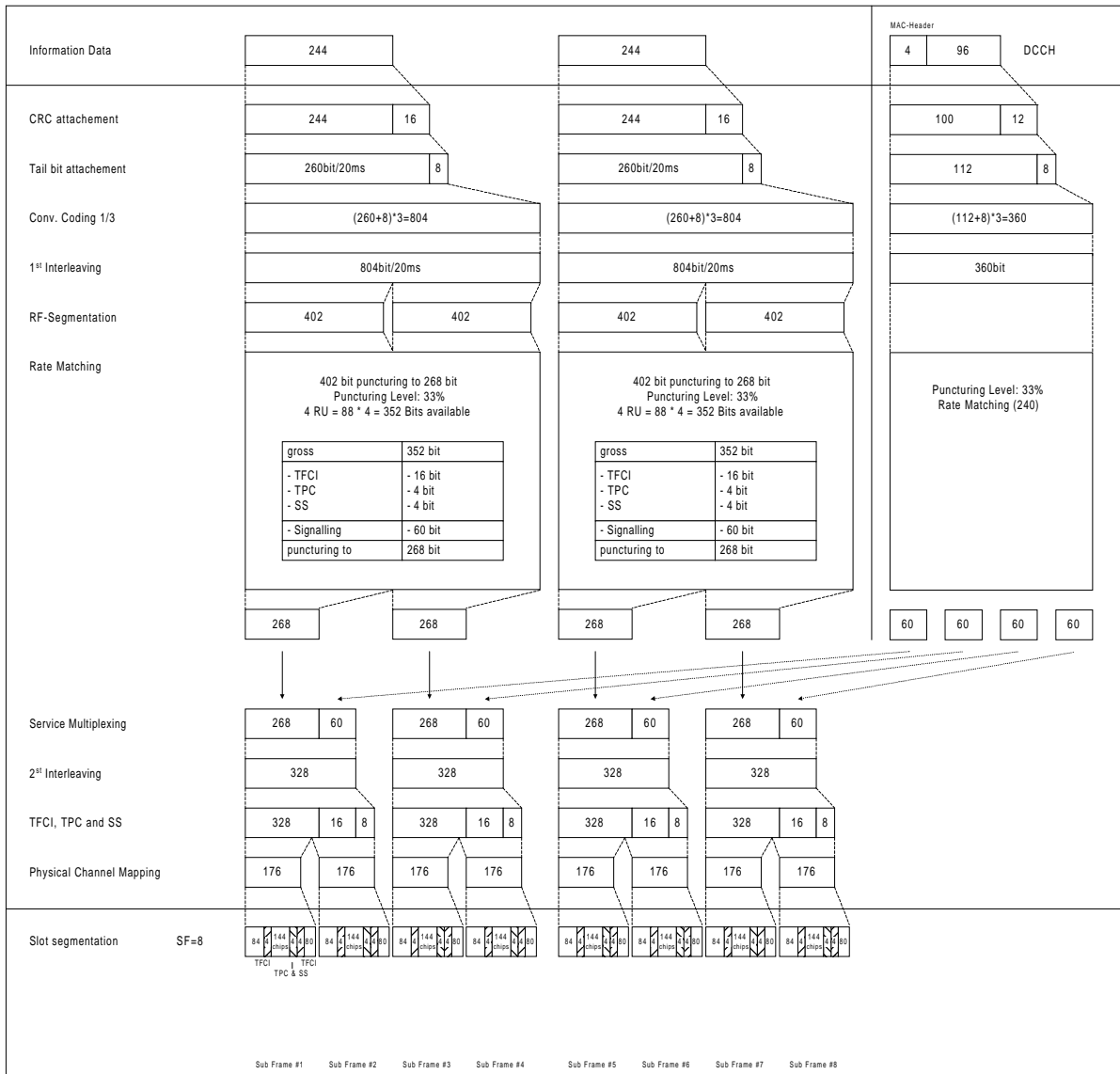

C.2.2 UL multi code reference measurement channel (12.2 kbps)

C.2.2.1 3.84 Mcps TDD Option

Parameter	
Information data rate	12.2 kbps
RU's allocated	2 RU
Midamble	512 chips
Interleaving	20 ms
Power control	2 Bit/user
TFCI	16 Bit/user
Inband signalling DCCH	2 kbps
Puncturing level at Code rate 1/3 : DCH / DCCH	5% / 0 %

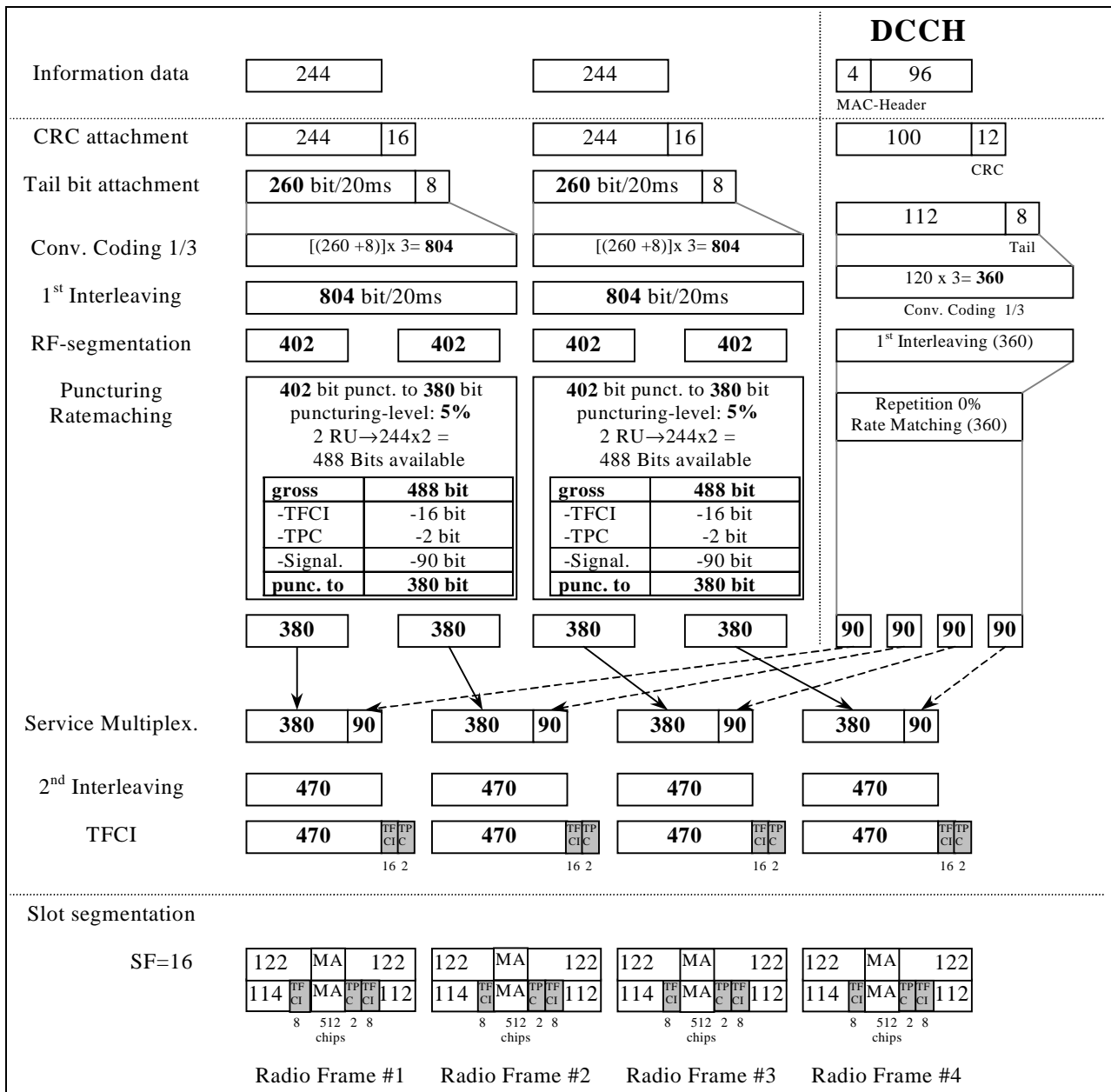

C.2.2.2 UL multi code reference measurement channel (12.2 kbps) for 1.28 Mcps TDD Option

Table A.7A

Parameter	Value
Information data rate	12.2 kbps
RU's allocated	1TS (2*SF16) = 2RU/5ms
Midamble	144
Interleaving	20 ms
Power control (TPC)	4 Bit/user/10ms
TFCI	16 Bit/user/10ms
4 Bit reserved for future use (place of SS)	4 Bit/user/10ms
Inband signalling DCCH	2.4 kbps
Puncturing level at Code rate 1/3: DCH / DCCH	33% / 33%

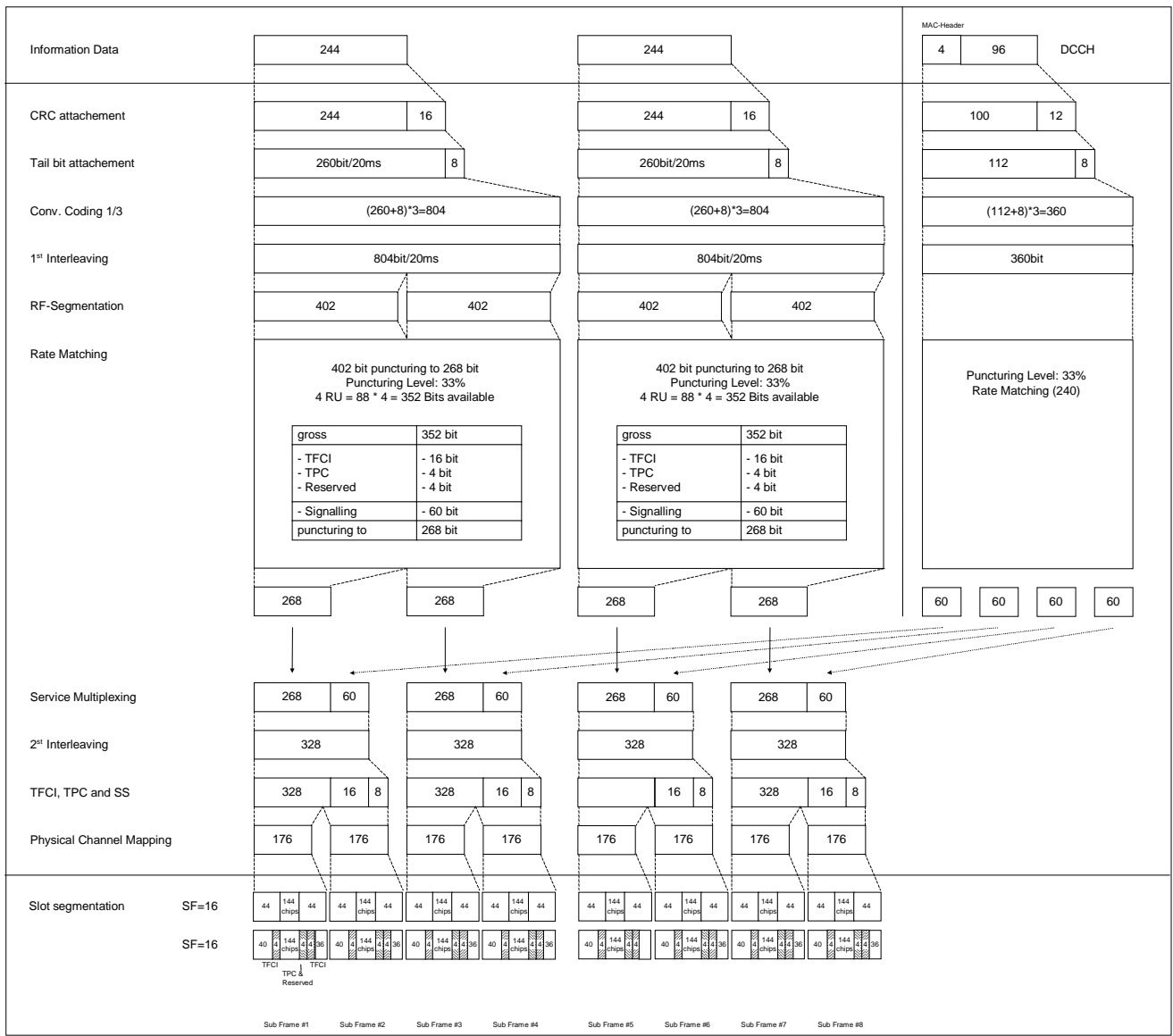

C.2.3 UL reference measurement channel (64 kbps)

Parameter	
Information data rate	64 kbps
RU's allocated	1 SF4 + 1 SF16 = 5RU
Midamble	512 chips
Interleaving	20 ms
Power control	2 Bit/user
TFCI	16 Bit/user
Inband signalling DCCH	2 kbps
Puncturing level at Code rate : 1/3 DCH / 1/2 DCCH	41.2% / 10%

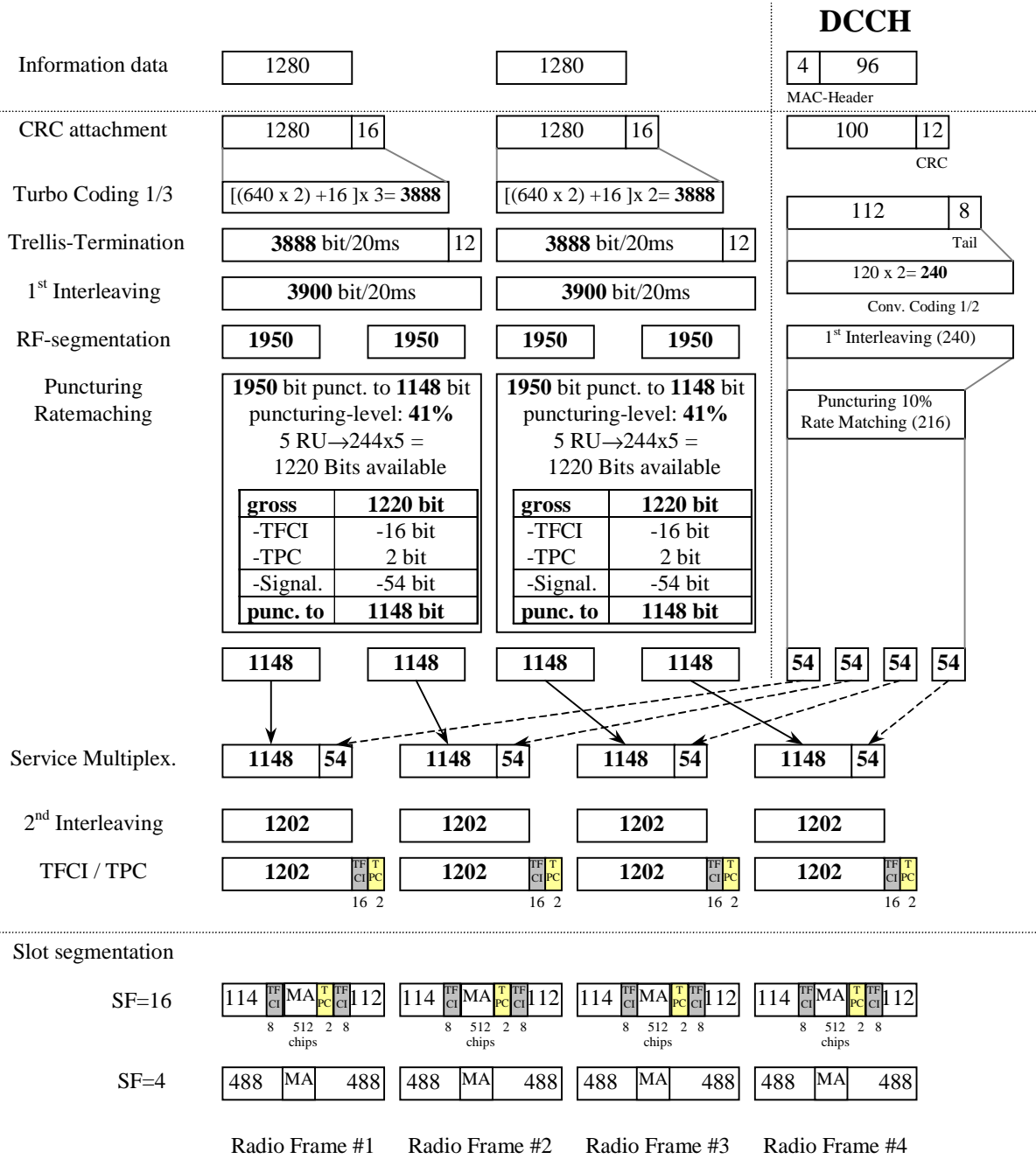

C.2.4 UL reference measurement channel (144 kbps)

Parameter	
Information data rate	144 kbps
RU's allocated	1 SF2 + 1 SF16 = 9RU
Midamble	256 chips
Interleaving	20 ms
Power control	2 Bit/user
TFCI	16 Bit/user
Inband signalling DCCH	2 kbps
Puncturing level at Code rate : 1/3 DCH / 1/2 DCCH	44.4% / 16.6%

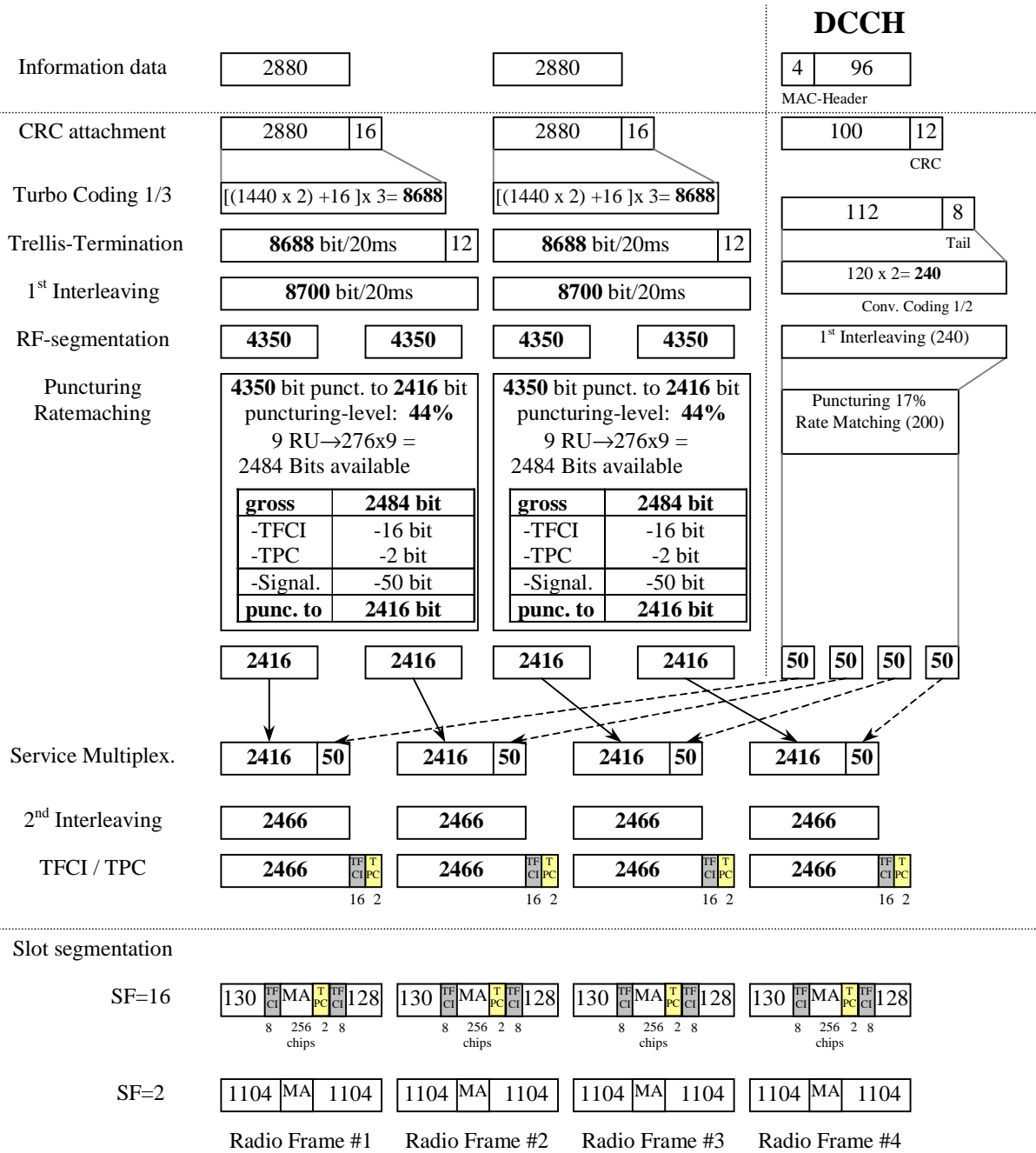

C.2.5 UL reference measurement channel (384 kbps)

Parameter	
Information data rate	384 kbps
RU's allocated	8*3TS = 24RU
Midamble	256 chips
Interleaving	20 ms
Power control	2 Bit/user
TFCI	16 Bit/user
Inband signalling DCCH	2 kbps
Puncturing level at Code rate : 1/3 DCH / 1/2 DCCH	43.4% / 15.3%

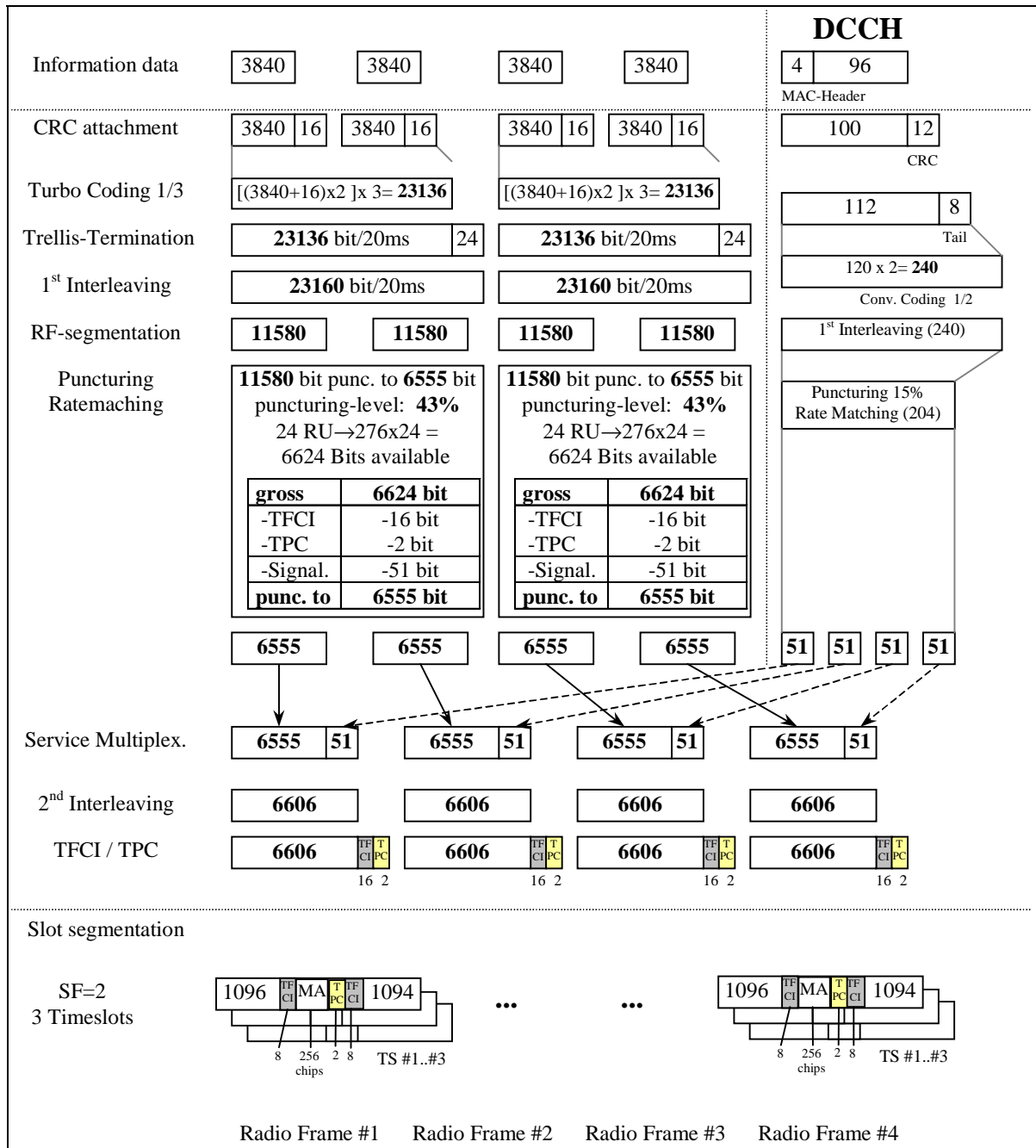

C.3 DL Reference measurement channels

C.3.13 DL reference measurement channel (12.2 kbps)

C.3.1.1 3.84 Mcps TDD Option

Parameter	
Information data rate	12.2 kbps
RU's allocated	2 RU
Midamble	512 chips
Interleaving	20 ms
Power control	0 Bit/user
TFCI	16 Bit/user
Inband signalling DCCH	2 kbps
Puncturing level at Code rate 1/3 : DCH / DCCH	5% / 0 %

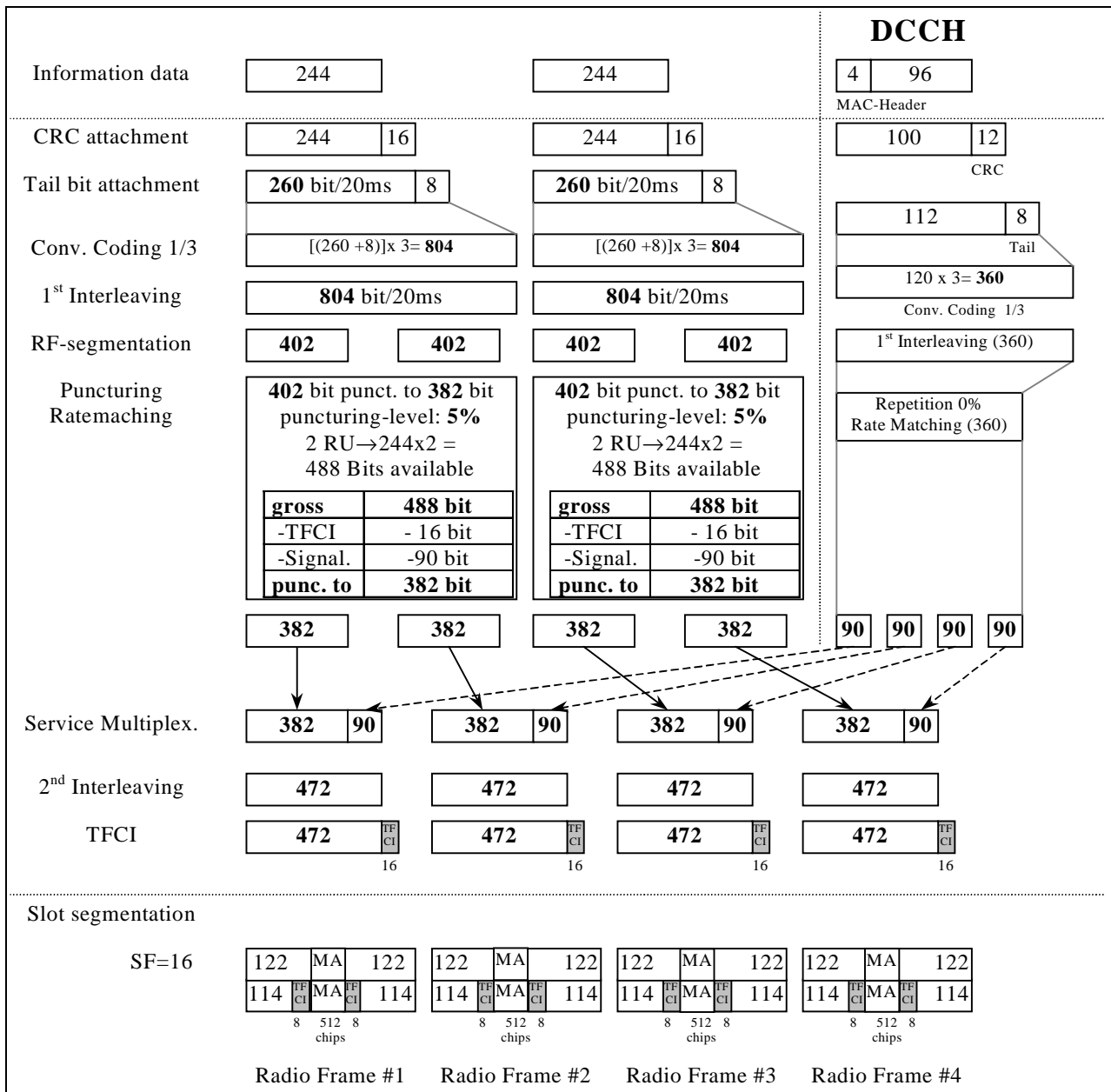

C.3.1.2 DL reference measurement channel (12.2 kbps) for 1.28 Mcps TDD Option

Table C.3.1.2

Parameter	Value
Information data rate	12.2 kbps
RU's allocated	1TS (2*SF16) = 2RU/5ms
Midamble	144
Interleaving	20 ms
Power control (TPC)	4 Bit/user/10ms
TFCI	16 Bit/user/10ms
Synchronisation Shift (SS)	4 Bit/user/10ms
Inband signalling DCCH	2.4 kbps
Puncturing level at Code rate 1/3: DCH / DCCH	33% / 33%

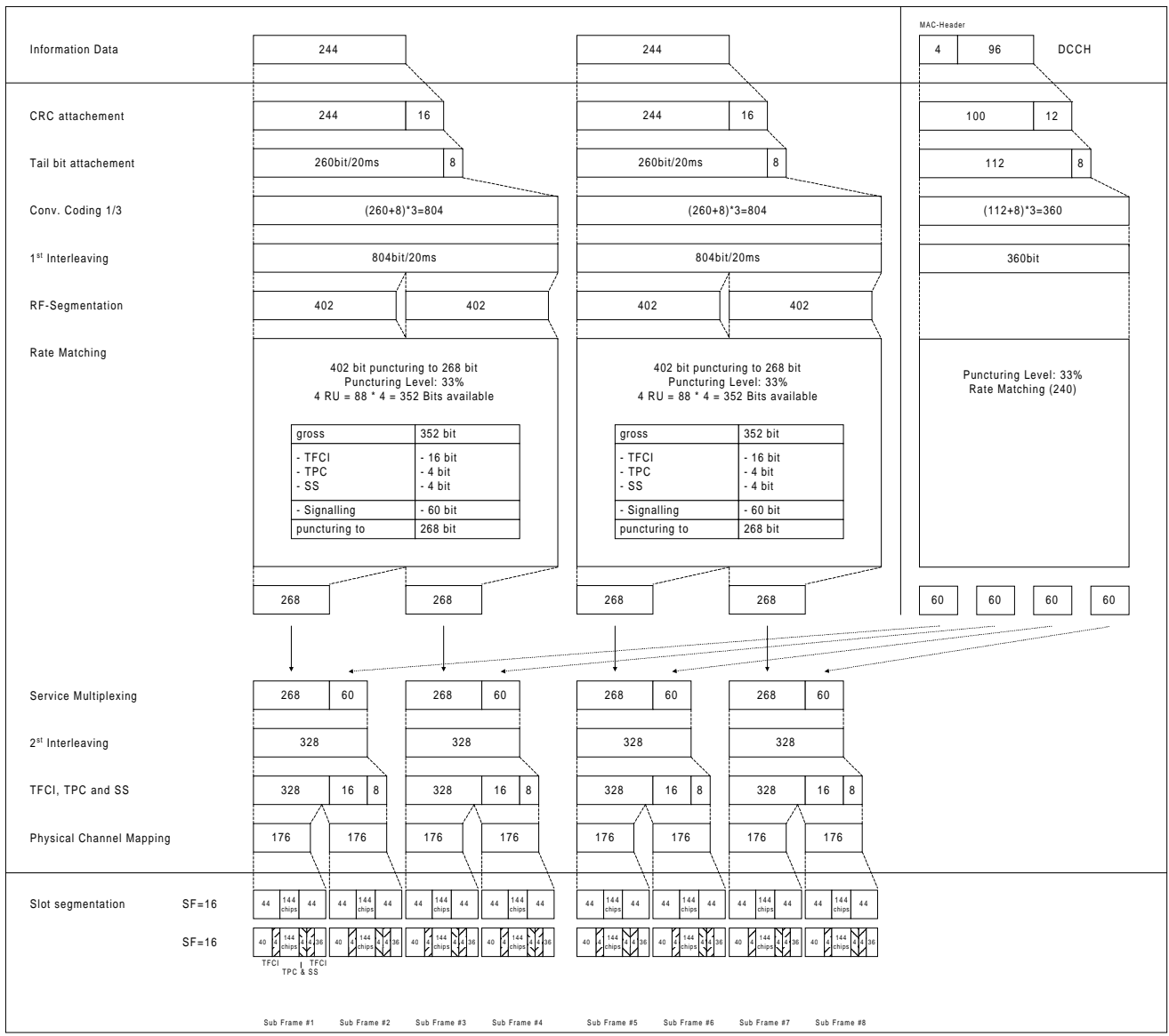

C.3.2 DL reference measurement channel (64 kbps)

C.3.2.1 3.84 Mcps TDD Option

Parameter	
Information data rate	64 kbps
RU's allocated	5 codes SF16 = 5RU
Midamble	512 chips
Interleaving	20 ms
Power control	0 Bit/user
TFCI	16 Bit/user
Inband signalling DCCH	2 kbps
Puncturing level at Code rate : 1/3 DCH / 1/2 DCCH	41.1% / 10%

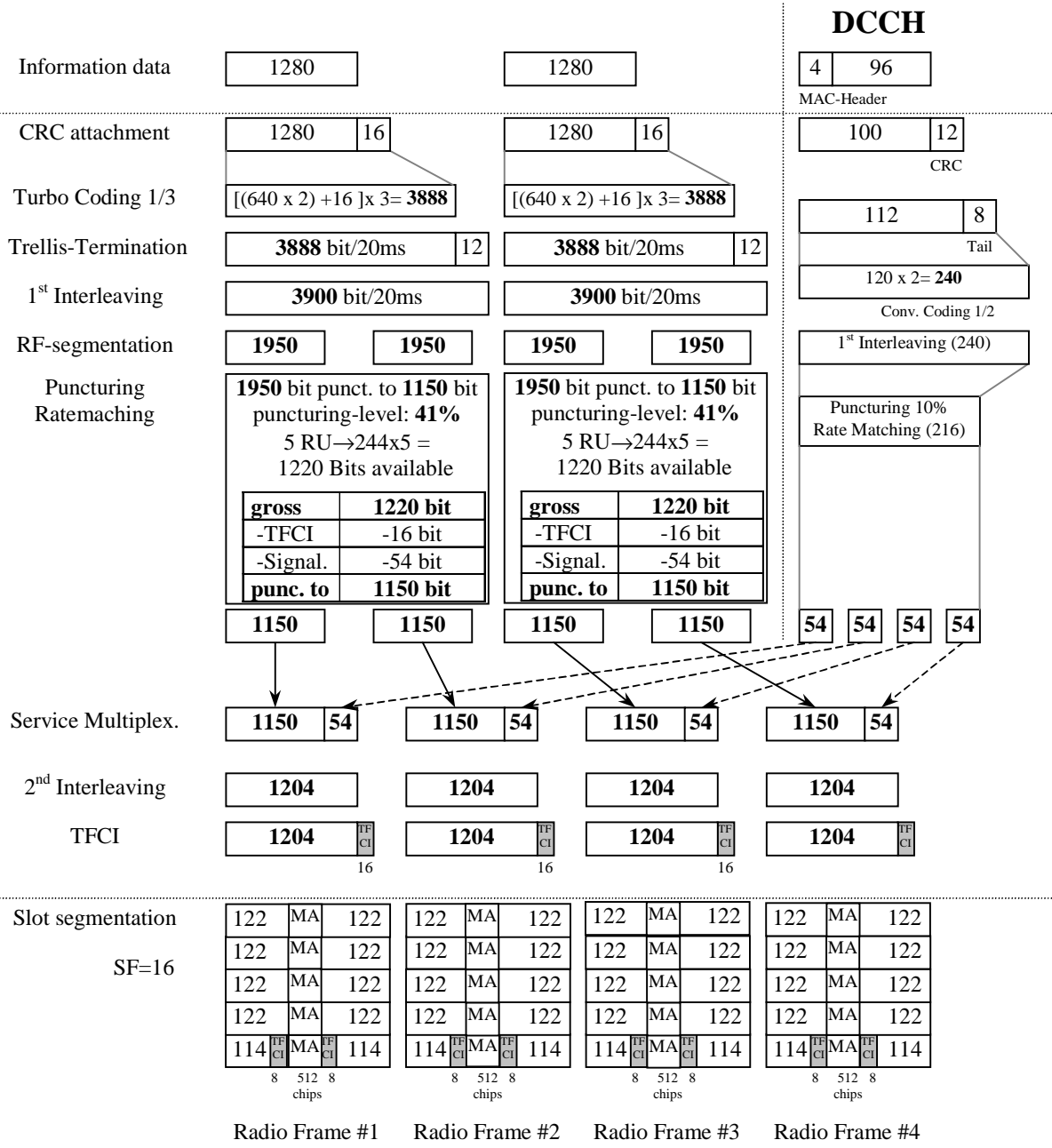

C.3.2.2 DL reference measurement channel (64 kbps) for 1.28 Mcps TDD Option

Table C.3.2.2

Parameter	Value
Information data rate	64 kbps
RU's allocated	1TS (8*SF16) = 8RU/5ms
Midamble	144
Interleaving	20 ms
Power control (TPC)	4 Bit/user/10ms
TFCI	16 Bit/user/10ms
Synchronisation Shift (SS)	4 Bit/user/10ms
Inband signalling DCCH	2.4 kbps
Puncturing level at Code rate: 1/3 DCH / 1/2 DCCH	32% / 0

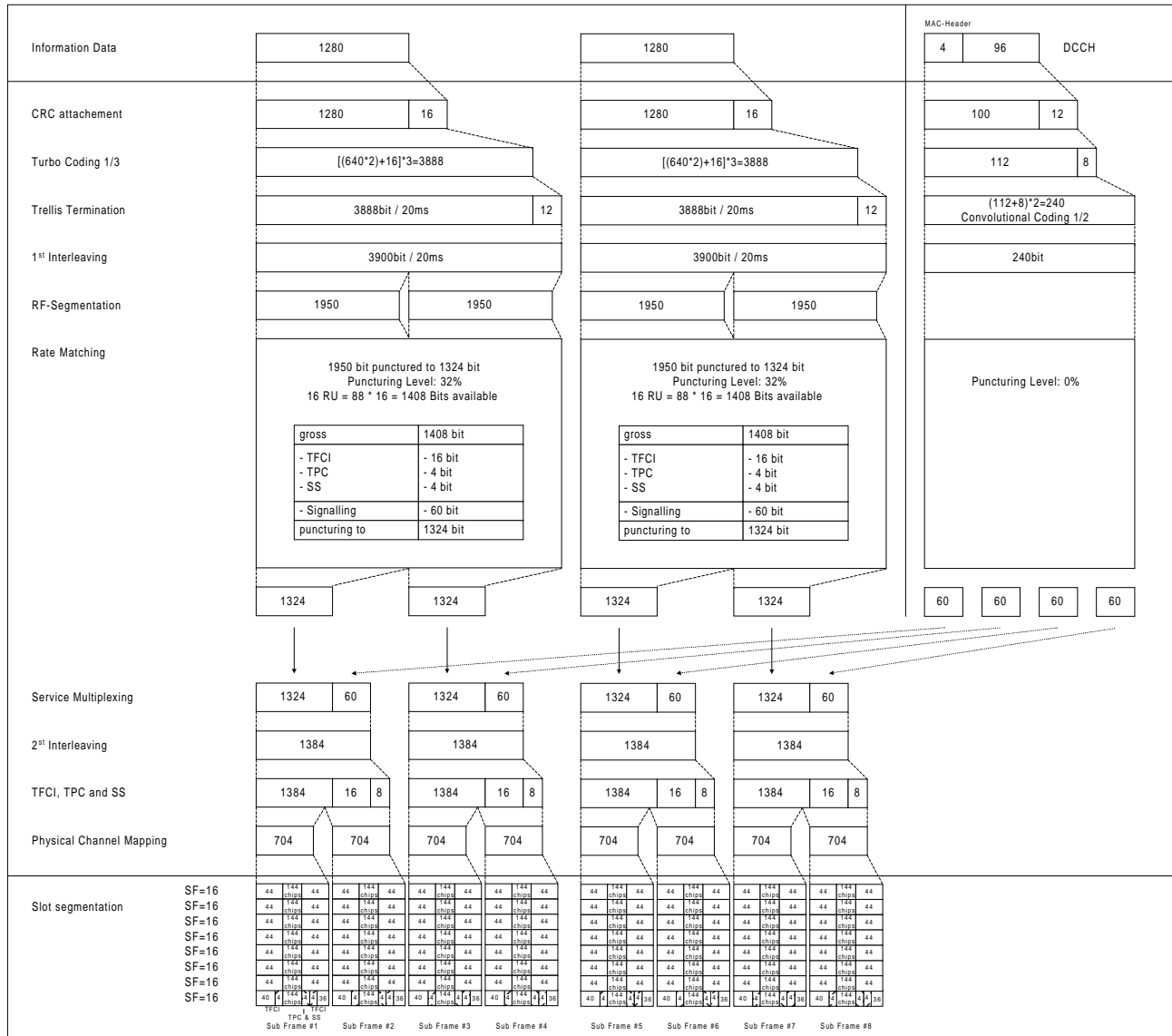

C.3.3 DL reference measurement channel (144 kbps)

C.3.3.1 3.84 Mcps TDD Option

Parameter	
Information data rate	144 kbps
RU's allocated	9 codes SF16 = 9RU
Midamble	256 chips
Interleaving	20 ms
Power control	0 Bit/user
TFCI	16 Bit/user
Inband signalling DCCH	2 kbps
Puncturing level at Code rate: 1/3 DCH / 1/2 DCCH	44.5% / 16.6%

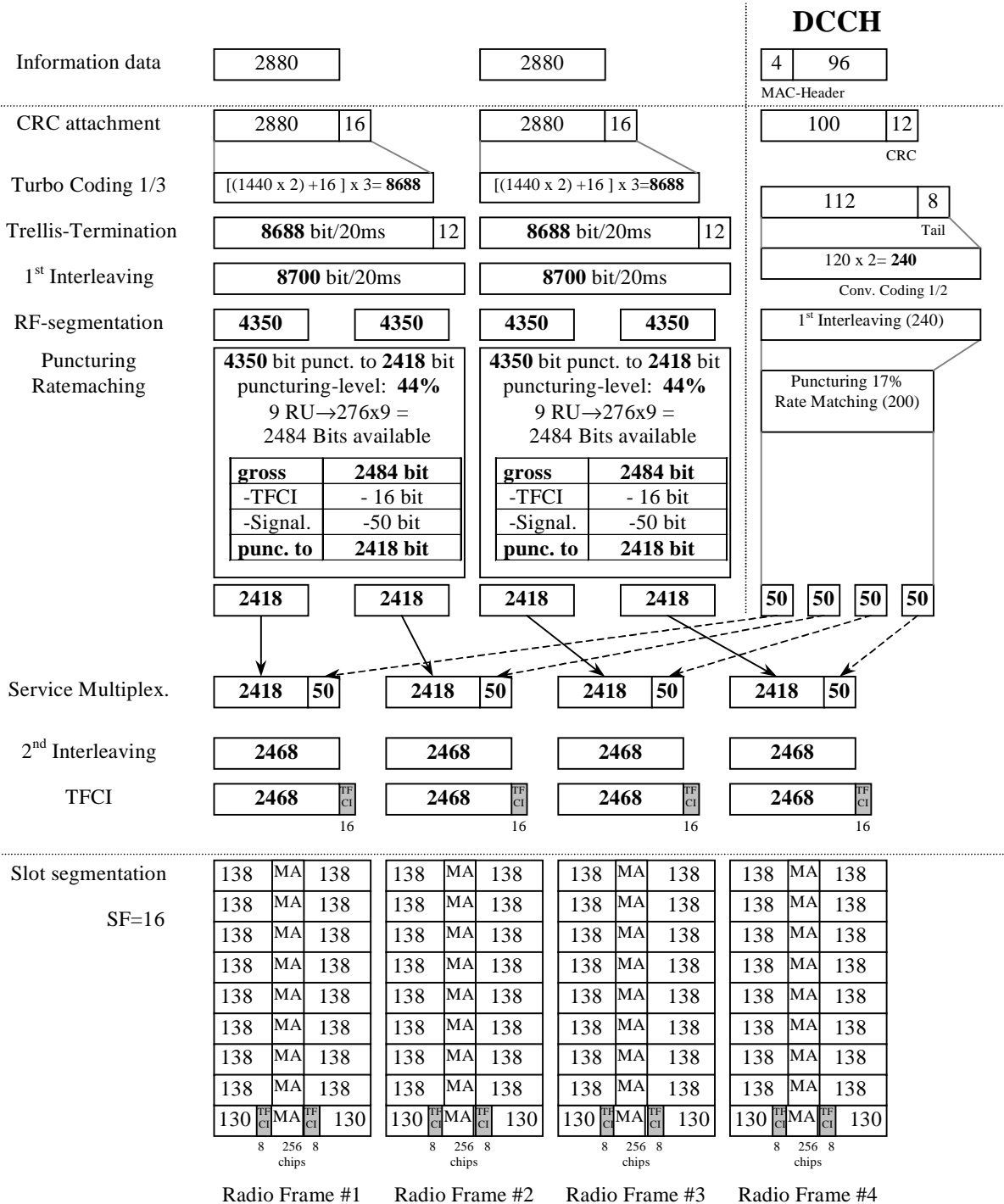

C.3.3.2 DL reference measurement channel (144 kbps) for 1.28 Mcps TDD Option

Table C.3.3.2

Parameter	Value
Information data rate	144 kbps
RU's allocated	2TS (8*SF16) = 16RU/5ms
Midamble	144
Interleaving	20 ms
Power control (TPC)	8 Bit/user/10ms
TFCI	32 Bit/user/10ms
Synchronisation Shift (SS)	8 Bit/user/10ms
Inband signalling DCCH	2.4 kbps
Puncturing level at Code rate: 1/3 DCH / 1/2 DCCH	38% / 7%

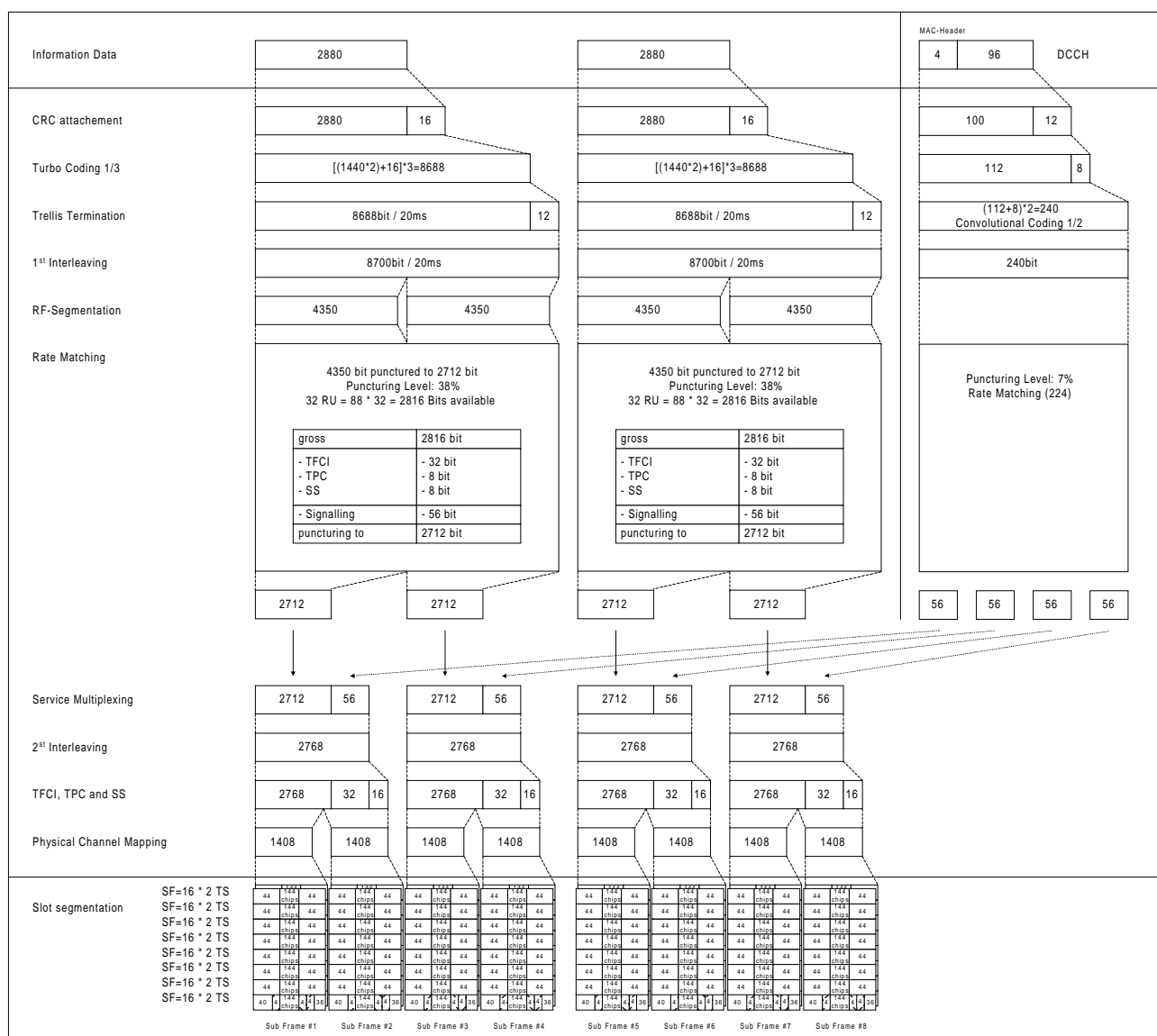

C.3.4 DL reference measurement channel (384 kbps)

C.3.4.1 3.84 Mcps TDD Option

Parameter	
Information data rate	384 kbps
RU's allocated	8*3TS = 24RU
Midamble	256 chips
Interleaving	20 ms
Power control	0 Bit/user
TFCI	16 Bit/user
Inband signalling DCCH	2 kbps
Puncturing level at Code rate : 1/3 DCH / 1/2 DCCH	43.4% / 15.3%

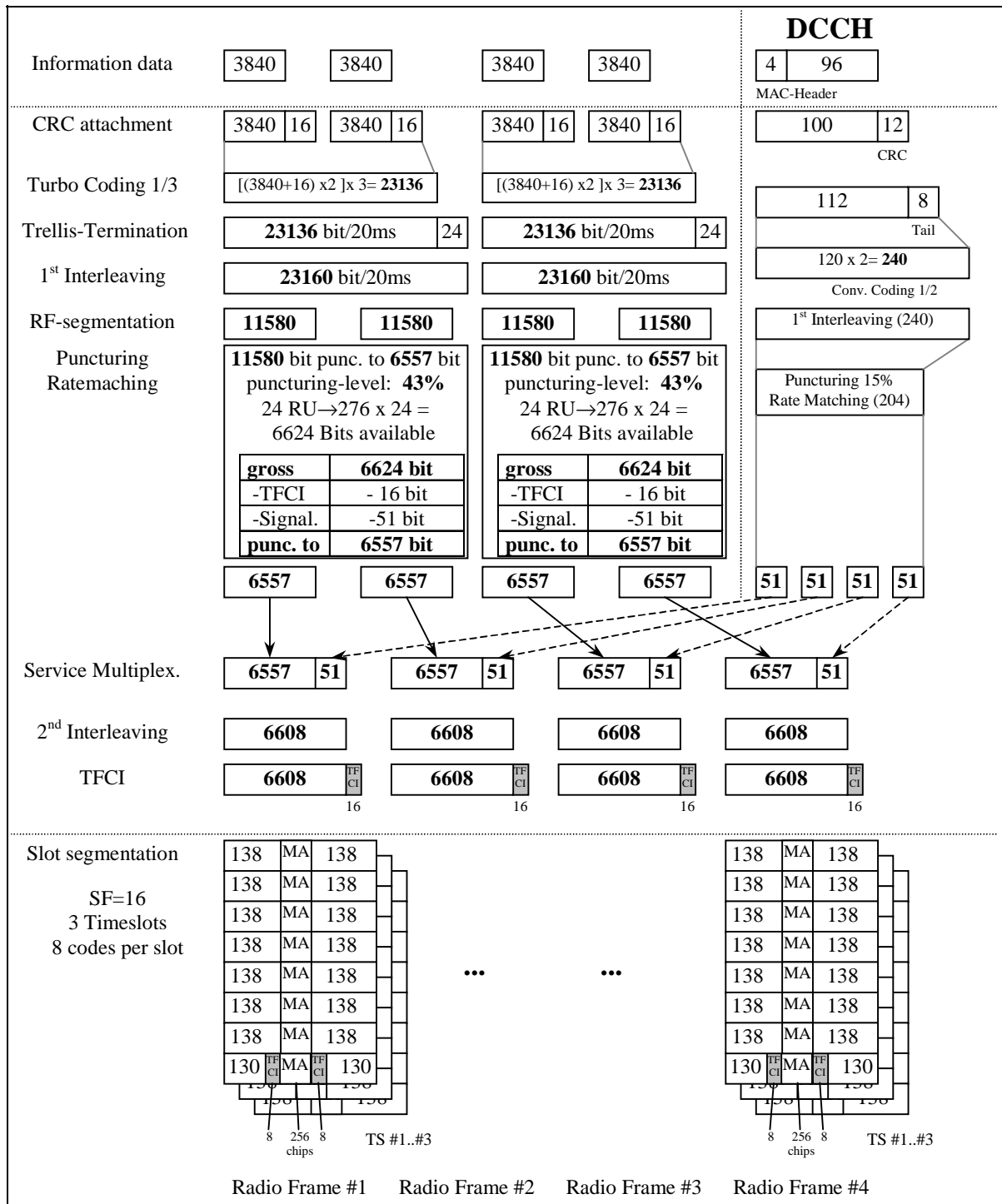

C.3.4.2 DL reference measurement channel (384 kbps) for 1.28 Mcps TDD Option

Table C.3.4.2

Parameter	Value
Information data rate	384 kbps
RU's allocated	4TS (10*SF16) = 40RU/5ms
Midamble	144
Interleaving	20 ms
Power control (TPC)	16 Bit/user/10ms
TFCI	64 Bit/user/10ms
Synchronisation Shift (SS)	16 Bit/user/10ms
Inband signalling DCCH	max.2 kbps
Puncturing level at Code rate: 1/3 DCH / 1/2 DCCH	41% / 12%

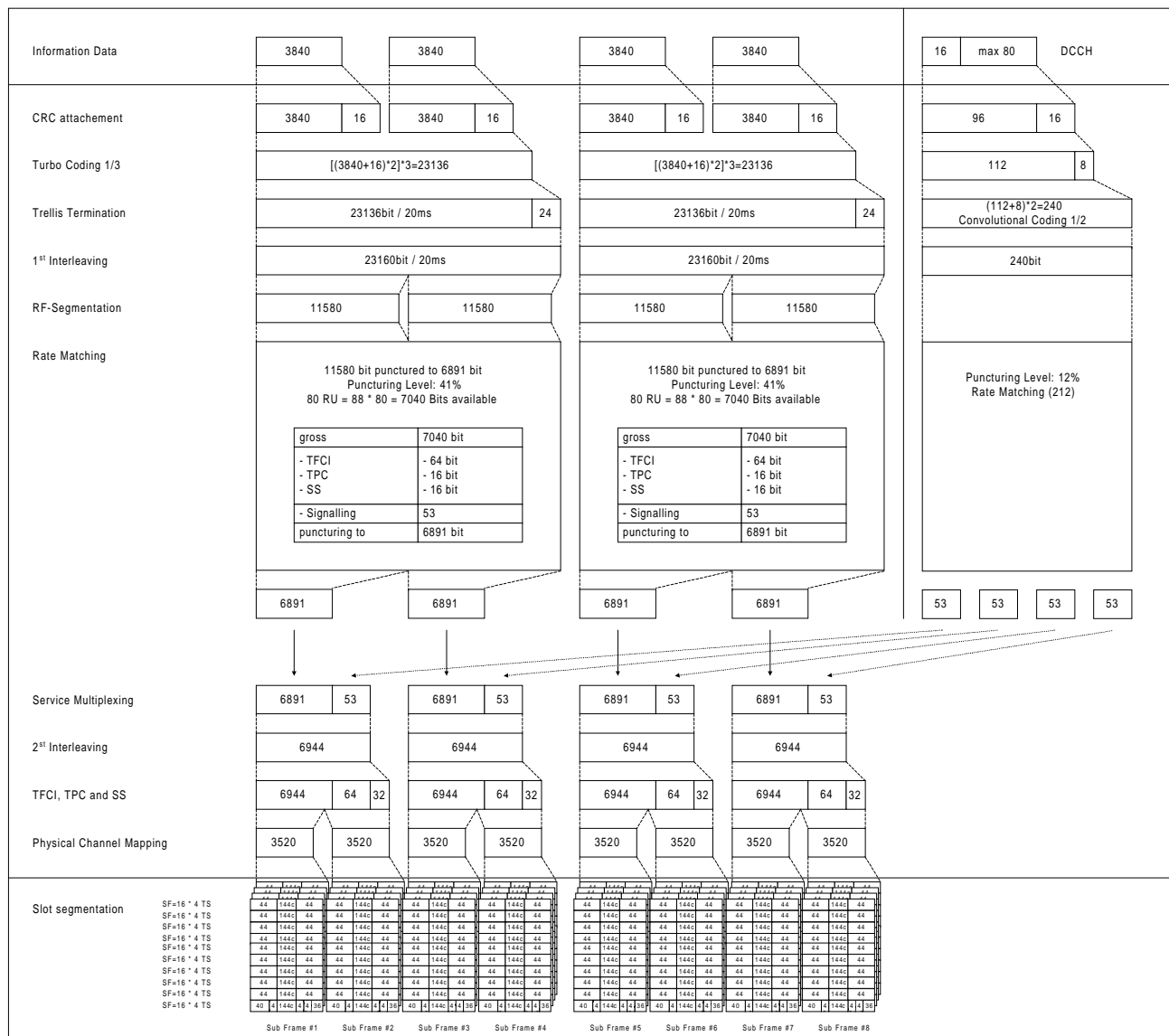

C.3.5 BCH reference measurement channel

C.3.5.1 3.84 Mcps TDD Option

[mapped to 1 code SF16]

Parameter	
Information data rate:	12.3 kbps
RU's allocated	1 RU
Midamble	512 chips
Interleaving	20 ms
Power control	0 bit
TFCI	0 bit
Puncturing level	10%

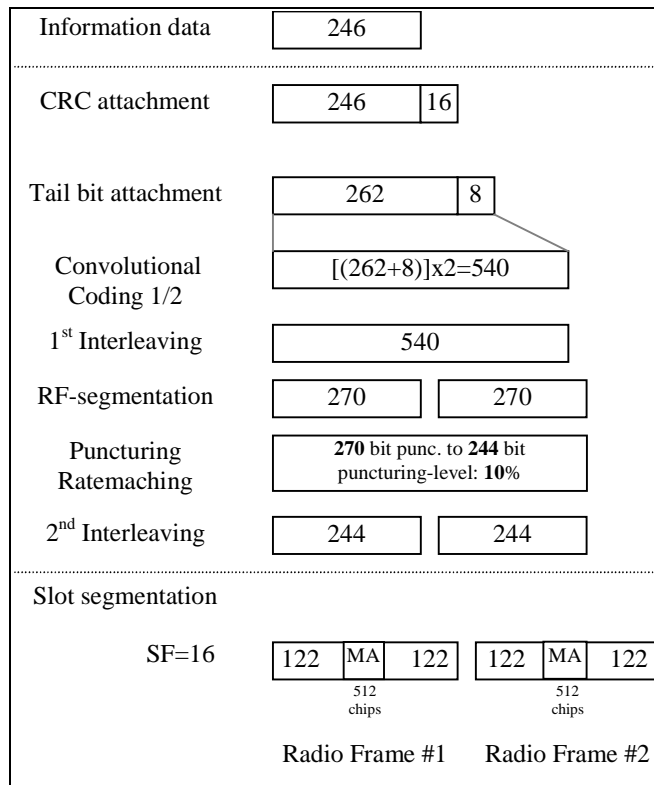

C.3.5.2 BCH reference measurement channel (12.3 kbps) for 1.28 Mcps TDD Option

Table C.3.5.2

Parameter	Value
Information data rate:	12.3 kbps
RU's allocated	2 RU
Midamble	144 chips
Interleaving	20 ms
Power control	0 bit
TFCI	0 bit
Puncturing level	13%

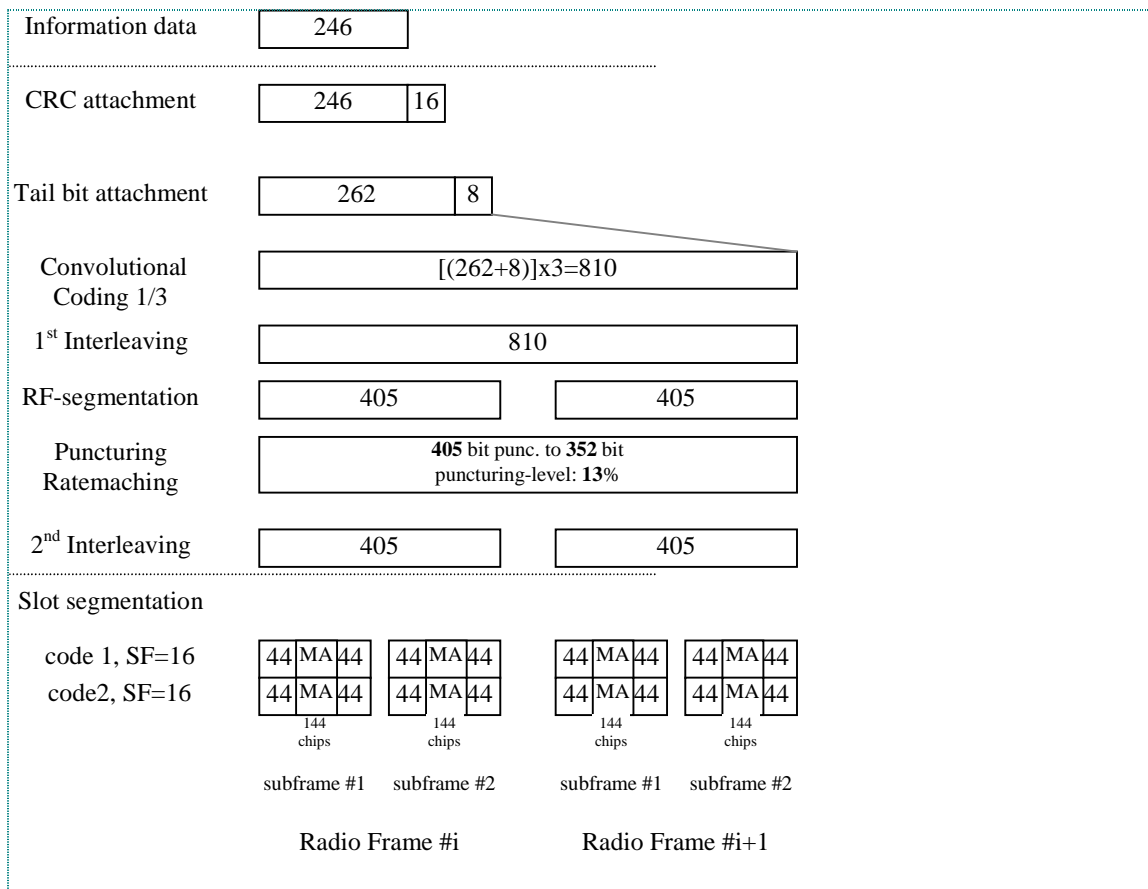

C.3.6 DL reference measurement channel (2 Mbps) for 3.84 Mcps TDD Option

Table C.3.6

Parameter	Value
Information data rate	2048 kbps
RU's allocated	16*12TS = 192RU
Midamble	256 chips
Interleaving	10 ms
Power control	0 Bit/user
TFCI	16 Bit/user
Inband signalling DCCH	2 kbps
Puncturing level at Code rate 1/3 : DCH / DCCH	13.9% / 0%

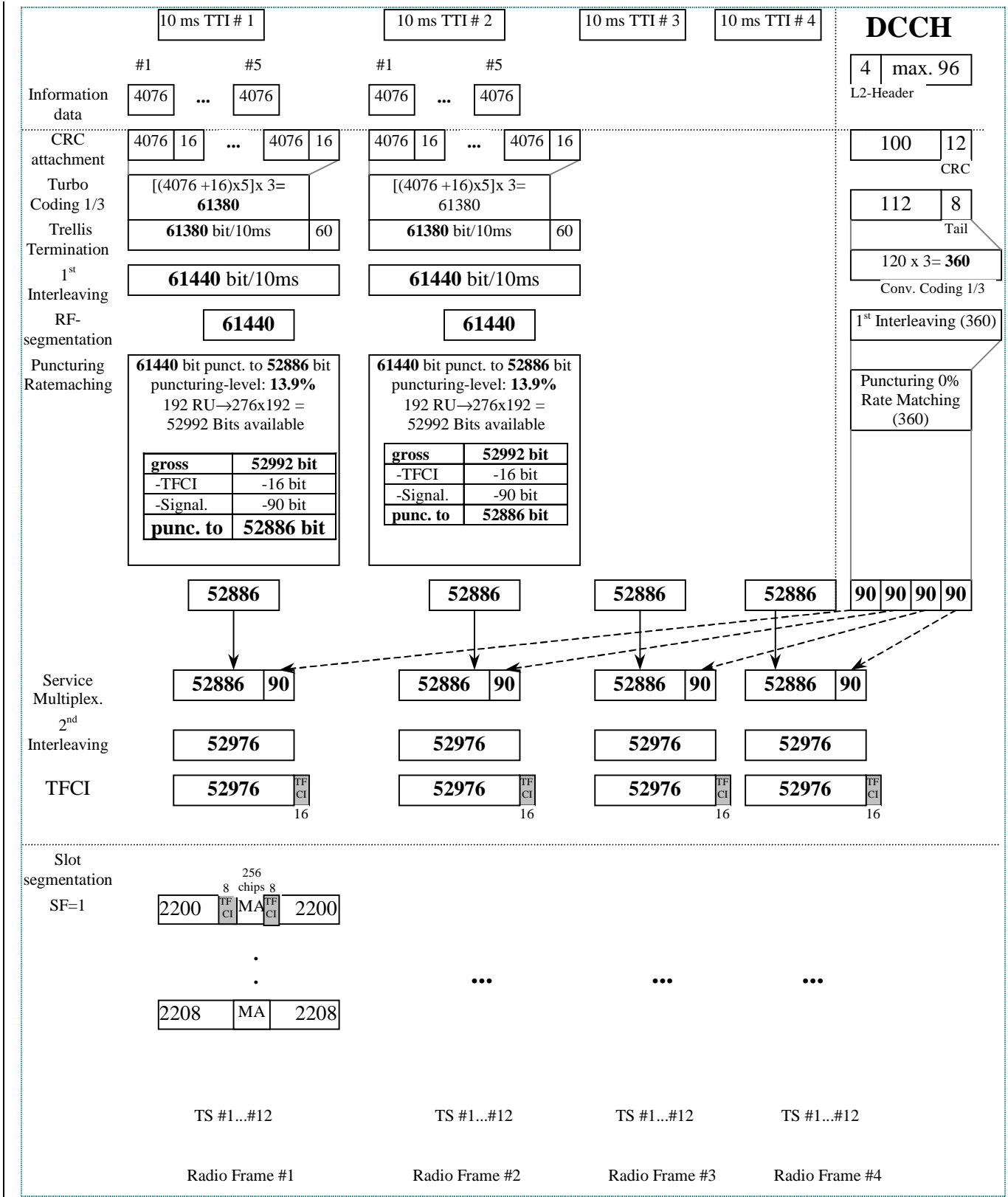

Annex D (normative): Propagation conditions

D.1 Test Environments

Table D.1 details the test services, the information data and the propagation conditions

Table D.1: Test Environments for UE Performance Specifications

Test Services	Information Data Rate	Static	Multipath Case 1	Multipath Case 2	Multipath Case 3
		Performance metric			
Paging Message			-	-	-
FACH Message			-	-	-
Circuit Switched Services	12.2 kbps	BLER <	BLER <	BLER <	BLER <
	64 kbps	BLER <	BLER <	BLER <	BLER <
	144 kbps	BLER <	BLER <	BLER <	BLER <
	384 kbps	BLER <	BLER <	BLER <	BLER <
	2048 kbps	BLER <	-	-	-
Packet Switched Data	TBD	TBD	TBD	TBD	TBD

D.2 Propagation Conditions

D.2.1 Static propagation condition

The propagation for the static performance measurement is an Additive White Gaussian Noise (AWGN) environment. No fading and multi-paths exist for this propagation model.

D.2.2 Multi-path fading propagation conditions

[D2.2.1 3.84 Mcps TDD Option](#)

Table D.2.2.1 shows propagation conditions that are used for the performance measurements in multi-path fading environment. All taps have classical Doppler spectrum.

Table D.2.2.1: Propagation Conditions for Multi path Fading Environments

Case 1, speed 3km/h		Case 2, speed 3 km/h		Case 3, 120 km/h		Case 4, 3 km/h	
Relative Delay [ns]	Average Power [dB]	Relative Delay [ns]	Average Power [dB]	Relative Delay [ns]	Average Power [dB]	Relative Delay [ns]	Average Power [dB]
0	0	0	0	0	0	0	0
976	-10	976	0	260	-3	976	0
		12000	0	521	-6		
				781	-9		

D.2.2.2 1.28 Mcps TDD Option

Table D2.2.2 shows propagation conditions that are used for the performance measurements in multi-path fading environment. All taps have classical Doppler spectrum.

Table D.2.2.2: Propagation Conditions for Multi-Path Fading Environments

<u>Case 1, speed 3km/h</u>		<u>Case 2, speed 3km/h</u>		<u>Case 3, speed 120km/h</u>	
<u>Relative Delay [ns]</u>	<u>Average Power [dB]</u>	<u>Relative Delay [ns]</u>	<u>Average Power [dB]</u>	<u>Relative Delay [ns]</u>	<u>Average Power [dB]</u>
<u>0</u>	<u>0</u>	<u>0</u>	<u>0</u>	<u>0</u>	<u>0</u>
<u>2928</u>	<u>-10</u>	<u>2928</u>	<u>0</u>	<u>781</u>	<u>-3</u>
		<u>12000</u>	<u>0</u>	<u>1563</u>	<u>-6</u>
				<u>2344</u>	<u>-9</u>

Annex E (normative): Common RF test conditions

E.1 General

This normative annex specifies the common RF test conditions that are needed for setting a connection and channels that are needed during a connection.

E.2 Connection Set-up

Table E.2 describes the downlink Physical Channels that are required for connection set up.

Table E.2: Downlink Physical Channels required for connection set-up

Physical Channel
PSCH
PCCPCH
DPCH
PICH

E.3 During connection

The following clauses describes the uplink and downlink Physical Channels that are transmitted during a connection i.e., when measurements are done.

E.3.1 Measurement of Tx Characteristics

Table E.3.1 is applicable for measurements on the Transmitter Characteristics (Section 5) with the exception of clause 5.2 (UE maximum output power), 5.3 (Frequency Stability), 5.4.1 (Uplink Power Control). For these cases certain parameters are defined individually.

Table E.3.1.1: Common downlink test condition RF parameters

Physical Channel	Power
DPCH	-93 dBm Data content PRBS
PSCH	TBD
PCCPCH	TBD
PICH	TBD
OCNS	Nothing

Table E.3.1.2: Common TX test parameters

Parameter	Value/description
UL Reference measurement channel	12.2kbps, according to annex C.2.1
Uplink Power Control	SS level and signalling values such that UE transmits maximum power.
Data content	real life (sufficient irregular)

E.3.2 Measurement of Rx Characteristics

Table E.3.2 is applicable for measurements on the Receiver Characteristics (Section 6)

Table E.3.2: Downlink Physical Channels transmitted during a connection.

Physical Channel	Power
CPICH	TBD
PCCPCH	TBD
SCH	TBD
PICH	TBD
DPCH	TBD

E.3.3 Measurement of Performance requirements

Table E.3.3 is applicable for measurements on the Performance requirements (Section 7)

Table E.3.3: Downlink Physical Channels transmitted during a connection.

Physical Channel	Power	Note
CPICH	TBD	
PCCPCH	TBD	
SCH	TBD	
PICH	TBD	
DPCH	TBD	
OCNS	TBD	

Annex F (normative): General test conditions and declarations

The requirements of this clause apply to all applicable tests in this specification.

Many of the tests in this specification measure a parameter relative to a value that is not fully specified in the UE specifications. For these tests, the Minimum Requirement is determined relative to a nominal value specified by the manufacturer.

When specified in a test, the manufacturer shall declare the nominal value of a parameter, or whether an option is supported.

.In all the relevant subclauses in this clause all Bit Error Ratio (BER), Block Error Ratio (BLER) measurements shall be carried out according to the general rules for statistical testing in annex F.6.

F.1 Acceptable uncertainty of Test System

The maximum acceptable uncertainty of the Test System is specified below for each test, where appropriate. The Test System shall enable the stimulus signals in the test case to be adjusted to within the specified range, and the equipment under test to be measured with an uncertainty not exceeding the specified values. All tolerances and uncertainties are absolute values, and are valid for a confidence level of 95 %, unless otherwise stated.

A confidence level of 95% is the measurement uncertainty tolerance interval for a specific measurement that contains 95% of the performance of a population of test equipment.

For RF tests it should be noted that the uncertainties in subclause F.1 apply to the Test System operating into a nominal 50 ohm load and do not include system effects due to mismatch between the DUT and the Test System.

F.1.1 Measurement of test environments

The measurement accuracy of the UE test environments defined in Annex G, Test environments shall be.

- Pressure ± 5 kPa.
- Temperature ± 2 degrees.
- Relative Humidity ± 5 %.
- DC Voltage $\pm 1,0$ %.
- AC Voltage $\pm 1,5$ %.
- Vibration 10 %.
- Vibration frequency 0,1 Hz.

The above values shall apply unless the test environment is otherwise controlled and the specification for the control of the test environment specifies the uncertainty for the parameter.

F.1.2 Measurement of transmitter

Table F.1.2 Maximum Test System Uncertainty for transmitter tests

Subclause	Maximum Test System Uncertainty
5.2 UE Maximum Output Power	± 0.7 dB
5.3 Frequency Stability	± 10 Hz
5.4.1 Uplink power control	Relative $\pm [0.3]$ dB
5.4.2 Minimum Transmit Power	± 1.0 dB
5.4.3 Transmit OFF Power	± 1.5 dB
5.4.4 Transmit ON/OFF Power	TBD
5.4.5 Out-of-synchronisation handling of output power	TBD
5.5.1 Occupied Bandwidth	± 100 kHz
5.5.2.1 Spectrum emission mask	± 1.5 dB
5.5.2.2 ACLR	5 MHz offset: ± 0.8 dB 10 MHz offset: ± 0.8 dB
5.5.3 Spurious emissions	± 2.0 dB for UE and coexistence bands for results > -60 dBm ± 3.0 dB for results < -60 dBm Outside above: $f \leq 2.2$ GHz : ± 1.5 dB 2.2 GHz < $f \leq 4$ GHz : ± 2.0 dB $f > 4$ GHz : ± 4.0 dB
5.6 Transmit intermodulation:	Will be based on BS, need to work out freq and level ranges.
5.7.1 Transmit modulation: EVM	± 2.5 %
5.7.2 Transmit modulation: peak code domain error	± 1 dB

F.1.3 Measurement of receiver

Table F.1.3 Maximum Test System Uncertainty for receiver tests

Subclause	Maximum Test System Uncertainty
6.2 Reference Sensitivity Level	± 0.7 dB
6.3 maximum input level:	TBD
6.4 Adjacent Channel Selectivity (ACS)	Overall system uncertainty ± 1.1 dB
6.5 Blocking Characteristics	Using ± 0.7 dB for signal and interferer as currently defined, and 68 dB ACLR @ 10 MHz. System error with $f < 15$ MHz offset: ± 1.4 dB $f \geq 15$ MHz offset and $f \leq 2.2$ GHz: $\pm [1.0]$ dB 2.2 GHz $< f \leq 4$ GHz : $\pm [1.7]$ dB $f > 4$ GHz: $\pm [3.1]$ dB
6.6 Spurious Response	$f < 2.2$ GHz: ± 1.0 dB $2.2 < f < 4$ GHz: ± 1.7 dB $f > 4$ GHz: ± 3.1 dB
6.7 Intermodulation Characteristics	Assume ± 0.7 dB for all signals. Overall uncertainty = $\pm [0.6]$ dB Needs further analysis
6.8 Spurious Emissions	± 3.0 dB for UE receive band (-78 dBm) Outside above: $f \leq 2.2$ GHz : ± 2.0 dB (-57 dBm) 2.2 GHz $< f \leq 4$ GHz : ± 2.0 dB (-47 dBm) $f > 4$ GHz : ± 4.0 dB (-47 dBm)

F.1.4 Performance requirement

Table F.1.4 Maximum Test System Uncertainty for Performance Requirements

Subclause	Maximum Test System Uncertainty
TBD	TBD

F.1.5 Requirements for support of RRM

TBD

F.2 Test Tolerances (This subclause is informative)

The Test Tolerances defined in this subclause have been used to relax the Minimum Requirements in this specification to derive the Test Requirements.

The Test Tolerances are derived from Test System uncertainties, regulatory requirements and criticality to system performance. As a result, the Test Tolerances may sometimes be set to zero.

The test tolerances should not be modified for any reason e.g. to take account of commonly known test system errors (such as mismatch, cable loss, etc.).

F.2.1 Transmitter

Table F.2.1 Test Tolerances for transmitter tests.

Subclause	Test Tolerance
5.2 Maximum Output Power	0.7 dB
5.3 UE Frequency Stability	10 Hz
5.4.2 Minimum Transmit Power	1.0 dB
5.4.5 Out-of-synchronisation handling of output power: $\frac{DPCCH_E_c}{I_{or}}$	[0.3] dB
5.4.5 Out-of-synchronisation handling of output power: transmit ON/OFF time	0 ms
5.5.1 Transmit OFF power	1.5 dB
5.5.1 Occupied Bandwidth	0 kHz
5.5.2.1 Spectrum emission mask	1.5 dB
5.5.2.2 Adjacent Channel Leakage Power Ratio (ACLR)	0.8 dB
5.5.3 Spurious Emissions	0 dB
5.6 Transmit Intermodulation	0 dB
5.7.1 Error Vector Magnitude	0%
5.7.2 Peak code domain error	1.0 dB

Note:

Unless explicitly specified test tolerances are set to be equal in the case of 3.84 Mcps TDD Option as well as in the case of 1.28 Mcps TDD Option.

F.2.2 Receiver

Table F.2.2 Test Tolerances for receiver tests.

Subclause	Test Tolerance
6.2 Reference sensitivity level	0.7 dB
6.4 Adjacent channel selectivity	0 dB
6.5 Blocking characteristics	0 dB
6.6 Spurious Response	0 dB
6.7 Intermodulation Characteristics	0 dB
6.8 Spurious emissions	0 dB

Note:

Unless explicitly specified test tolerances are set to be equal in the case of 3.84 Mcps TDD Option as well as in the case of 1.28 Mcps TDD Option.

F.2.3 Performance requirements

Table F.2.3 Test Tolerances for Performance Requirements.

Subclause	Test Tolerance
7.2, Demodulation in Static Propagation Condition	
7.3, Demodulation of DCH in Multiplath Fading conditions	
7.4, Base Station Transmit diversity modes	

F.2.4 Requirements for support of RRM

TBD

F.3 Interpretation of measurement results

The measurement results returned by the Test System are compared - without any modification - against the Test Requirements as defined by the shared risk principle.

The Shared Risk principle is defined in ETR 273 Part 1 sub-part 2 section 6.5.

The actual measurement uncertainty of the Test System for the measurement of each parameter shall be included in the test report.

The recorded value for the Test System uncertainty shall be, for each measurement, equal to or lower than the appropriate figure in subclause F.1 of this specification.

If the Test System for a test is known to have a measurement uncertainty greater than that specified in subclause F.1, it is still permitted to use this apparatus provided that an adjustment is made value as follows.

Any additional uncertainty in the Test System over and above that specified in subclause F.1 shall be used to tighten the Test Requirement – making the test harder to pass. (For some tests e.g. receiver tests, this may require modification of stimulus signals). This procedure will ensure that a Test System not compliant with subclause F.1 does not increase the chance of passing a device under test where that device would otherwise have failed the test if a Test System compliant with subclause F.1 had been used.

F.4 Derivation of Test Requirements (This subclause is informative)

The Test Requirements in this specification have been calculated by relaxing the Minimum Requirements of the core specification using the Test Tolerances defined in subclause F.2. When the Test Tolerance is zero, the Test Requirement will be the same as the Minimum Requirement. When the Test Tolerance is non-zero, the Test Requirements will differ from the Minimum Requirements, and the formula used for this relaxation is given in table F.4.

Table F.4. Derivation of Test Requirements

Test	Minimum Requirement in TS 25.102	Test Tolerance (TT)	Test Requirement in TS 34.122
5.2 Maximum Output Power	Power single code Power class 2 (24 dBm) Tolerance = +1/-3 dB Power class 3 (21 dBm) Tolerance = +2/-2 dB Power multi code Power class 2 (21 dBm) Tolerance = +1/-3 dB Power class 3 (18 dBm) Tolerance = ±2 dB	0.7 dB	Formula: Upper Tolerance limit + TT Lower Tolerance limit – TT For power classes 2 (single and multi): Upper Tolerance limit = +1.7 dB Lower Tolerance limit = -3.7 dB For power class 3 (single and multi): Upper Tolerance limit = +2.7 dB Lower Tolerance limit = -2.7 dB
5.3 UE Frequency Stability	The UE modulated carrier frequency shall be accurate to within ±0.1 ppm compared to the carrier frequency received from the Node B.	10 Hz	Formula: modulated carrier frequency error + TT modulated carrier frequency error = ±(0.1 ppm + 10 Hz).
5.4.2 Minimum Transmit Power	UE minimum transmit power shall be less than –44 dBm	1.0 dB	Formula: UE minimum transmit power + TT UE minimum transmit power = –43 dBm
5.4.5 Out-of-synchronisation handling of output power:	$\frac{DPCCH_E_c}{I_{or}}$ levels before A –4.6 dB AB: -10 dB BD: -16 dB DE: -12 dB EF: -6 dB transmit ON/OFF time 200ms	[0.3] dB for $\frac{DPCCH_E_c}{I_{or}}$ 0 ms for timing measurement	Formulas: Ratio between A and B + TT Ratio between B and D - TT Ratio between D and E - TT Ratio between E and F + TT transmit ON/OFF time + TT timing $\frac{DPCCH_E_c}{I_{or}}$ levels: Before A: -4.6 AB: -10 + [0.3] dB BD: -16 – [0.3] dB DE: -12 - [0.3] dB EF: -6 + [0.3] dB Uncertainty of OFF power measurement is handled by Transmit OFF power test and uncertainty of ON power measurement is handled by Minimum output power test.transmit ON/OFF time 200ms
5.5.1 Transmit OFF power	Transmit OFF power shall be less than –65 dBm	1.5 dB	Formula: Transmit OFF power + TT Transmit OFF power = –63.5 dBm
5.5.1 Occupied Bandwidth	The occupied channel bandwidth shall be less than 5 MHz based on a chip rate of 3.84 Mcps.	0 kHz	Formula: occupied channel bandwidth: + TT occupied channel bandwidth = 5.0 MHz
5.5.2.1 Spectrum emission mask	Minimum requirement defined in TS25.101 Table 6.10. The lower limit shall be –50 dBm / 3.84 MHz or which ever is higher.	1.5 dB	Formula: Minimum requirement + TT Lower limit + TT Add 1.5 to Minimum requirement entries in TS25.101 Table 6.10 The lower limit shall be –48.5 dBm / 3.84 MHz or which ever is higher.

5.5.2.2 Adjacent Channel Leakage Power Ratio (ACLR)	Power Classes 2 and 3: UE channel +5 MHz or -5 MHz, ACLR limit: 33 dB UE channel +10 MHz or -10 MHz, ACLR limit: 43 dB		0.8 dB	Formula: ACLR limit - TT Power Classes 2 and 3: UE channel +5 MHz or -5 MHz, ACLR limit: 32.2 dB UE channel +10 MHz or -10 MHz, ACLR limit: 42.2 dB	
5.5.3 Spurious Emissions				Formula: Minimum Requirement+ TT Add zero to all the values of Minimum Requirements in table 5.5.3	
	Frequency Band	Minimum Requirement		Frequency Band	Minimum Requirement
	9 kHz ≤ f < 150 kHz	-36dBm /1kHz	0 dB	9kHz ≤ f < 1GHz	-36dBm /1kHz
	150 kHz ≤ f < 30 MHz	-36dBm /10kHz	0 dB	150 kHz ≤ f < 30 MHz	-36dBm /10kHz
	30 MHz ≤ f < 1000 MHz	-36dBm /100kHz	0 dB	30 MHz ≤ f < 1000 MHz	-36dBm /100kHz
	1 GHz ≤ f < 12.75 GHz	-30dBm /1MHz	0 dB	1 GHz ≤ f < 2.2 GHz	-30dBm /1MHz
			0 dB	2.2 GHz ≤ f < 4 GHz	-30dBm /1MHz
			0 dB	4 GHz ≤ f < 12.75 GHz	-30dBm /1MHz
	925 MHz < f < 935 MHz	-67dBm /100kHz	0 dB	925 MHz < f < 935 MHz	-67dBm /100kHz
	935 MHz ≤ f ≤ 960 MHz	-79dBm /100kHz	0 dB	935 MHz ≤ f ≤ 960 MHz	-79dBm /100kHz
	1805 MHz < f ≤ 1880 MHz	-71dBm /100kHz	0 dB	1805 MHz < f ≤ 1880 MHz	-71dBm /100kHz
	1805 MHz ≤ f ≤ 1880 MHz	-71dBm /100kHz	0 dB	1805 MHz ≤ f ≤ 1880 MHz	-71dBm /100kHz

5.6 Transmit Intermodulation	Intermodulation Product 5MHz -31 dBc 10MHz -41 dBc	0 dB	Formula: Intermodulation Product + TT Intermodulation Product 5MHz -31 dBc 10MHz -41 dBc	
5.7.1 Error Vector Magnitude	The Error Vector Magnitude shall not exceed 17.5 %	0%	Formula: EVM limit + TT EVM limit = 17.5 %	
5.7.2 Peak code domain error	The peak code domain error shall not exceed -21dB	±1.0 dB	Formula: Peak code domain error + TT Peak code domain error = -20 dB	
6.2 Reference sensitivity level	$\hat{I}_{or} = -105 \text{ dBm} / 3.84 \text{ MHz}$ BER limit = 0.001	0.7 dB	Formula: $\hat{I}_{or} + T$ BER limit unchanged $\hat{I}_{or} = -104.3 \text{ dBm} / 3.84 \text{ MHz}$	
6.4 Adjacent Channel Selectivity	$\hat{I}_{or} = -91 \text{ dBm} / 3.84 \text{ MHz}$ $I_{oac}(\text{modulated}) = -52 \text{ dBm} / 3.84 \text{ MHz}$ BER limit = 0.001	0 dB	Formula: \hat{I}_{or} unchanged $I_{oac} - TT$ BER limit unchanged $I_{oac} = -52 \text{ dBm} / 3.84 \text{ MHz}$	
6.5 Blocking Characteristics	See Table 6.5.2a and 6.5.2b. in TS34.122 BER limit = 0.001	0 dB	Formula: $I_{\text{blocking}}(\text{modulated}) - TT$ (dBm/3.84MHz) $I_{\text{blocking}}(\text{CW}) - TT$ (dBm) BER limit unchanged	
6.6 Spurious Response	$I_{\text{blocking}}(\text{CW}) -44 \text{ dBm}$ Fuw: Spurious response frequencies BER limit = 0.001	0 dB	Formula: $I_{\text{blocking}}(\text{CW}) - TT$ (dBm) Fuw unchanged BER limit unchanged $I_{\text{blocking}}(\text{CW}) -44 \text{ dBm}$	
6.7 Intermodulation Characteristics	$I_{ouw1}(\text{CW}) -46 \text{ dBm}$ $I_{ouw2}(\text{modulated}) -46 \text{ dBm} / 3.84 \text{ MHz}$ Fuw1 (offset) 10 MHz Fuw2 (offset) 20 MHz BER limit = 0.001	0 dB	Formula: TBD BER limit unchanged.	
6.8 Spurious Emissions			Formula: Maximum level+ TT Add zero to all the values of Maximum Level in table 6.8.1.	
	Frequency Band	Maximum level	Frequency Band	Maximum level
	9kHz ≤ f < 1GHz	-57dBm /100kHz	0 dB	9kHz ≤ f < 1GHz -57dBm /100kHz
	1.9-1.92 GHz 2.01-2.025GHz 2.11-2.170GHz	-60 dBm / 3.84MHz	0 dB	1.9-1.92 GHz 2.01-2.025GHz 2.11-2.170GHz -60 dBm / 3.84MHz
	1 -1.9GHz, 1.92-2.01 GHz 2.025-2.11GHz	-47 dBm/1MHz	0 dB	1 -1.9GHz, 1.92-2.01 GHz 2.025-2.11GHz -47 dBm/1MHz
	1GHz ≤ f ≤ 12.75GHz	-47dBm /1MHz	0 dB	1GHz ≤ f ≤ 2.2GHz -47dBm /1MHz
0 dB			2.2GHz < f ≤ 4GHz -47dBm /1MHz	
		0 dB	4GHz < f ≤ 12.75GHz -47dBm /1MHz	

F.5 Acceptable uncertainty of Test Equipment (This subclause is informative)

This informative subclause specifies the critical parameters of the components of an overall Test System (e.g. Signal generators, Signal Analyzers etc.) which are necessary when assembling a Test System that complies with subclause F.1 Acceptable Uncertainty of Test System. These Test Equipment parameters are fundamental to the accuracy of the overall Test System and are unlikely to be improved upon through System Calibration.

F.5.1 Transmitter measurements

Table F.5.1 Equipment accuracy for transmitter measurements

Test	Equipment accuracy	Test conditions
5.2 UE Maximum Output Power	Not applicable	
5.3 Frequency Stability	± 10Hz	
5.4.1 Uplink power control		
5.4.2 Minimum Transmit Power		
5.4.3 Transmit OFF Power		
5.4.4 Transmit ON/OFF Power		
5.4.5 Out-of-synchronisation handling of output power $\frac{DPCCH - E_c}{I_{or}}$		
5.4.5 Out-of-synchronisation handling of output power: transmit ON/OFF time		
5.5.1 Occupied Bandwidth	100 kHz	
5.5.2.1 Spectrum emission mask	Not applicable	
5.5.2.2 ACLR		
5.5.3 Spurious emissions		
5.5.3 Spurious emissions: additional		
5.6 Transmit intermodulation:	Not applicable	
5.7.1 Transmit modulation: EVM	2.5 %	
5.7.2 Transmit modulation: peak code domain error	±[1 dB]	

F.5.2 Receiver measurements

Table F.5.2 Equipment accuracy for receiver measurements

Subclause	Equipment accuracy	Test conditions
6.2 Reference Sensitivity Level	Not applicable	
6.3 maximum input level:	Not applicable	
6.4 Adjacent Channel Selectivity (ACS)	Not applicable	
6.5 Blocking Characteristics	Not applicable	
6.6 Spurious Responce	Not applicable	
6.7 Intermodulation Characteristics	Not applicable	
6.8 Spurious Emissions	Not applicable	

F.5.3 Performance measurements

Table G.3 Equipment accuracy for performance measurements

Subclause	Equipment accuracy	Test conditions
TBD	TBD	

F.6 General rules for statistical testing

[TBD]

Annex G (normative): Environmental conditions

G.1 General

This normative annex specifies the environmental requirements of the UE. Within these limits the requirements of this specifications shall be fulfilled.

G.2 Environmental requirements

The requirements in this clause apply to all types of UE(s)

G.2.1 Temperature

The UE shall fulfil all the requirements in the full temperature range of:

+15°C to +35°C	for normal conditions (with relative humidity of 25 % to 75 %)
-10°C to +55°C	for extreme conditions (see IEC publications 68-2-1 and 68-2-2)

Outside this temperature range the UE, if powered on, shall not make ineffective use of the radio frequency spectrum. In no case shall the UE exceed the transmitted levels as defined in TS 25.101 [1] for extreme operation.

G.2.2 Voltage

The UE shall fulfil all the requirements in the full voltage range, i.e. the voltage range between the extreme voltages.

The manufacturer shall declare the lower and higher extreme voltages and the approximate shutdown voltage. For the equipment that can be operated from one or more of the power sources listed below, the lower extreme voltage shall not be higher, and the higher extreme voltage shall not be lower than that specified below.

Power source	Lower extreme voltage	Higher extreme voltage	Normal conditions voltage
AC mains	0,9 * nominal	1,1 * nominal	nominal
Regulated lead acid battery	0,9 * nominal	1,3 * nominal	1,1 * nominal
Non regulated batteries: Leclanché / lithium Mercury/nickel & cadmium	0,85 * nominal 0,90 * nominal	Nominal Nominal	Nominal Nominal

Outside this voltage range the UE if powered on, shall not make ineffective use of the radio frequency spectrum. In no case shall the UE exceed the transmitted levels as defined in [1] TS 25.101 for extreme operation. In particular, the UE shall inhibit all RF transmissions when the power supply voltage is below the manufacturer declared shutdown voltage.

G.2.3 Vibration

The UE shall fulfil all the requirements when vibrated at the following frequency/amplitudes:

Frequency	ASD (Acceleration Spectral Density) random vibration
5 Hz to 20 Hz	0,96 m ² /s ³
20 Hz to 500 Hz	0,96 m ² /s ³ at 20 Hz, thereafter –3 dB/Octave

Outside the specified frequency range the UE, if powered on, shall not make ineffective use of the radio frequency spectrum. In no case shall the UE exceed the transmitted levels as defined in TS 25.101 [1] for extreme operation.

Annex H (normative): Terminal Baseline and Service Implementation Capabilities (TDD)

H.1 Baseline Implementation Capabilities:

Table H.1: Baseline implementation capabilities

Capability TDD	Section	UE*	Comments
Chip rate 3.84 Mcps		M	
Frequency bands: (uplink and downlink)			
1900-1920 MHz		M	
2010-2025 MHz		M	
1850-1910 MHz		M	
1930-1990 MHz		M	
1910-1930 MHz		M	
Other spectrum		O	As Declared
Carrier raster 200 kHz		M	
UE maximum output power	6.2.1	M	2, 3

(* M = mandatory, O = optional)

- The special conformance testing functions and the logical test interface as specified in TS 34.109 [3]. This issue is currently under investigation.
- Uplink reference measurement channel 12.2 kbps (FDD), TS 25.102 [1] subclause A.2.1.
- Downlink reference measurement channel 12.2 kbps (FDD), TS 25.102 [1] subclause A.2.2.

H.2 Service Implementation Capabilities:

- Downlink reference measurement channel 64 kbps (TDD), TS 25.102 subclause A.2.3.
- Downlink reference measurement channel 144 kbps (TDD), TS 25.102 subclause A.2.4.
- Down-link reference measurement channel 384 kbps (TDD), TS 25.102 subclause A.2.5.
- BCH Reference Measurement Channel.

Annex I (informative): Change history

Meeting -1st- Level	Doc-1st- Level	CR	Rev	Subject	Cat	Version- Current	Version -New	Doc-2nd- Level
TP-08				Approval of the specification		2.0.0	3.0.0	
TP-09	TP-000134	001		Corrections to EVM and PCDE formulae (B.2.7.1, B2.7.2)	F	3.0.0	3.1.0	T1-000150
TP-10	TP-000217	002		Update of 34.122 according to RAN#9-approved CRs to	F	3.1.0	3.2.0	T1-000256
TP-10	TP-000217	003		Update according to former CRs to 25.102	F	3.1.0	3.2.0	T1-000257
TP-10	TP-000217	004		editorial corrections for: Global In-Channel TX- Test	D	3.1.0	3.2.0	T1-000259
TP-10	TP-000217	005		Handling of measurement uncertainties in UE conformance	F	3.1.0	3.2.0	T1-000262
TP-10	TP-000217	006		Uplink Power control	F	3.1.0	3.2.0	T1-000258
TP-10	TP-000217	007		UE maximum output power multicode	F	3.1.0	3.2.0	T1-000260
TP-10	TP-000217	008		Out-of-synchronisation handling of output power	F	3.1.0	3.2.0	T1-000261
TP-11	TP-010020	009		Test tolerance for 5.7.1 TDD EVM	F	3.2.0	3.3.0	T1-010048
TP-11	TP-010020	010		Test tolerance for 5.7.2 TDD PCDE	F	3.2.0	3.3.0	T1-010049
TP-11	TP-010020	011		Test tolerance for 5.2 Maximum Output Power test case	F	3.2.0	3.3.0	T1-010050
TP-11	TP-010020	012		Test tolerance for 5.3 Frequency Stability	F	3.2.0	3.3.0	T1-010051
TP-11	TP-010020	013		Test tolerance for 5.4.2 Minimum Transmit Output Power	F	3.2.0	3.3.0	T1-010052
TP-11	TP-010020	014		Test Tolerance for 5.4.3 Transmit OFF power	F	3.2.0	3.3.0	T1-010053
TP-11	TP-010020	015		Test tolerance for 5.4.5 Out-of-synchronisation handling of output power	F	3.2.0	3.3.0	T1-010054
TP-11	TP-010020	016		Test tolerance for 5.5.1 Occupied Bandwidth	F	3.2.0	3.3.0	T1-010055
TP-11	TP-010020	017		Test tolerance for 5.5.2.1 Spectrum Emission Mask	F	3.2.0	3.3.0	T1-010056
TP-11	TP-010020	018		Test tolerance for 5.5.2.2 ACLR test case	F	3.2.0	3.3.0	T1-010057
TP-11	TP-010020	019		Test Tolerance for 5.5.3 Spurious emissions	F	3.2.0	3.3.0	T1-010058
TP-11	TP-010020	020		Test Tolerance for 5.6 Transmit Intermodulation	F	3.2.0	3.3.0	T1-010059
TP-11	TP-010020	021		Test Tolerance for 6.2 Reference Sensitivity Level	F	3.2.0	3.3.0	T1-010060
TP-11	TP-010020	022		Test Tolerance for 6.4 Adjacent Channel Selectivity	F	3.2.0	3.3.0	T1-010061
TP-11	TP-010020	023		Test tolerances to 6.5 Blocking Characteristics	F	3.2.0	3.3.0	T1-010062
TP-11	TP-010020	024		Test tolerances to 6.6 Spurious Response	F	3.2.0	3.3.0	T1-010063
TP-11	TP-010020	025		Test tolerances to 6.7 Intermodulation Characteristics	F	3.2.0	3.3.0	T1-010064
TP-11	TP-010020	026		Test Tolerance for 6.5 RX Spurious Emissions	F	3.2.0	3.3.0	T1-010065
TP-11	TP-010020	027		Test tolerance for Annex F in TS34.122	F	3.2.0	3.3.0	T1-010068
TP-11	TP-010020	028		Correction concerning the coexistence of TDD and FDD in the same band	F	3.2.0	3.3.0	T1-010045
TP-11	TP-010020	029		Clarification of the mentioned parameter alpha	F	3.2.0	3.3.0	T1-010046
TP-11	TP-010020	030		Correction concerning the channel number calculation	F	3.2.0	3.3.0	T1-010047
TP-11	TP-010020	031		Correction concerning UE maximum output power classes	F	3.2.0	3.3.0	T1-010066
TP-11	TP-010020	032		Correction of Out-of-Sync criteria	F	3.2.0	3.3.0	T1-010067