

Source: T1
Title: CR's to TS 34.121 v3.4.0 for approval
Agenda item: 5.1.3
Document for: Approval

This document contains 15 CRs to TS 34.121 v3.4.0. These CRs have been agreed by T1 and are put forward to TSG T for approval.

CRs due to test tolerance issue:

Spec	CR	Rev	Phase	Subject	Cat	Version-Current	Version-New	Doc-2nd-Level
34.121	083		R99	CR: Addition of Test System uncertainties and Test Tolerances	F	3.4.0	3.5.0	T1-010139

CRs related to RRM:

Spec	CR	Rev	Phase	Subject	Cat	Version-Current	Version-New	Doc-2nd-Level
34.121	084		R99	CR: Measurement accuracy of CPICH RSCP	F	3.4.0	3.5.0	T1-010140
34.121	085		R99	CR: Measurement accuracy of CPICH Ec/Io	F	3.4.0	3.5.0	T1-010141
34.121	086		R99	CR: Modifications to the structure of RRM test cases (FDD)	F	3.4.0	3.5.0	T1-010142

CRs for maintenance:

Spec	CR	Rev	Phase	Subject	Cat	Version-Current	Version-New	Doc-2nd-Level
34.121	087		R99	Maintenance CR: Propagation condition 250 km/h	F	3.4.0	3.5.0	T1-010143
34.121	088		R99	Maintenance CR: Removal of square brackets	F	3.4.0	3.5.0	T1-010144
34.121	089		R99	Maintenance CR: Tx power for Rx characteristics measurement	F	3.4.0	3.5.0	T1-010145
34.121	090		R99	Maintenance CR: Correction of Definition of multi-code OCNS signal	F	3.4.0	3.5.0	T1-010146
34.121	091		R99	Maintenance CR: Conformance requirement to Minimum requirement	D	3.4.0	3.5.0	T1-010147
34.121	092		R99	Maintenance CR: Test conditions for TS 34.121	F	3.4.0	3.5.0	T1-010148
34.121	093		R99	Maintenance CR: Editorial correction 34.121	D	3.4.0	3.5.0	T1-010149
34.121	094		R99	Maintenance CR: closed loop power control close to the limits	C	3.4.0	3.5.0	T1-010150
34.121	095		R99	Maintenance CR: removal of annex I	D	3.4.0	3.5.0	T1-010151
34.121	096		R99	Maintenance CR: correction to annex E	F	3.4.0	3.5.0	T1-010152
34.121	097		R99	Maintenance CR: corrections to TS34.121	F	3.4.0	3.5.0	T1-010153

CHANGE REQUEST

⌘ **34.121 CR 083** ⌘ rev **-** ⌘ Current version: **3.4.0** ⌘

For **HELP** on using this form, see bottom of this page or look at the pop-up text over the ⌘ symbols.

Proposed change affects: ⌘ (U)SIM ME/UE Radio Access Network Core Network

Title:	⌘ Addition of Test System uncertainties and Test Tolerances		
Source:	⌘ T1/RF		
Work item code:	⌘	Date:	⌘ 16/05/01
Category:	⌘ F	Release:	⌘ R99
<p>Use <u>one</u> of the following categories:</p> <p>F (essential correction) A (corresponds to a correction in an earlier release) B (Addition of feature), C (Functional modification of feature) D (Editorial modification)</p> <p>Detailed explanations of the above categories can be found in 3GPP TR 21.900.</p>		<p>Use <u>one</u> of the following releases:</p> <p>2 (GSM Phase 2) R96 (Release 1996) R97 (Release 1997) R98 (Release 1998) R99 (Release 1999) REL-4 (Release 4) REL-5 (Release 5)</p>	

Reason for change:	⌘ To update Annex F according to recent work at TEM #04		
Summary of change:	⌘ Annex F is updated		
Consequences if not approved:	⌘ The test requirements for conformance tests will be incorrect		

Clauses affected:	⌘ Annex F.1, F.2, F.4		
Other specs affected:	<input type="checkbox"/> Other core specifications <input type="checkbox"/> Test specifications <input type="checkbox"/> O&M Specifications	⌘	
Other comments:	⌘		

How to create CRs using this form:

Comprehensive information and tips about how to create CRs can be found at: http://www.3gpp.org/3G_Specs/CRs.htm. Below is a brief summary:

- 1) Fill out the above form. The symbols above marked ⌘ contain pop-up help information about the field that they are closest to.
- 2) Obtain the latest version for the release of the specification to which the change is proposed. Use the MS Word "revision marks" feature (also known as "track changes") when making the changes. All 3GPP specifications can be downloaded from the 3GPP server under <ftp://www.3gpp.org/specs/> For the latest version, look for the directory name with the latest date e.g. 2000-09 contains the specifications resulting from the September 2000 TSG meetings.
- 3) With "track changes" disabled, paste the entire CR form (use CTRL-A to select it) into the specification just in front of the clause containing the first piece of changed text. Delete those parts of the specification which are not relevant to the change request.

Annex F (normative): General test conditions and declarations

The requirements of this clause apply to all applicable tests in this specification.

Many of the tests in this specification measure a parameter relative to a value that is not fully specified in the UE specifications. For these tests, the Minimum Requirement is determined relative to a nominal value specified by the manufacturer.

When specified in a test, the manufacturer shall declare the nominal value of a parameter, or whether an option is supported.

In all the relevant subclauses in this clause all Bit Error Ratio (BER), Block Error Ratio (BLER), False transmit format Detection Ratio (FDR) measurements shall be carried out according to the general rules for statistical testing in annex F.6.

F.1 Acceptable uncertainty of Test System

The maximum acceptable uncertainty of the Test System is specified below for each test, where appropriate. The Test System shall enable the stimulus signals in the test case to be adjusted to within the specified range, and the equipment under test to be measured with an uncertainty not exceeding the specified values. All ranges and uncertainties are absolute values, and are valid for a confidence level of 95 %, unless otherwise stated.

A confidence level of 95% is the measurement uncertainty tolerance interval for a specific measurement that contains 95% of the performance of a population of test equipment.

For RF tests it should be noted that the uncertainties in subclause F.1 apply to the Test System operating into a nominal 50 ohm load and do not include system effects due to mismatch between the DUT and the Test System.

F.1.1 Measurement of test environments

The measurement accuracy of the UE test environments defined in Annex G, Test environments shall be.

- Pressure ± 5 kPa.
- Temperature ± 2 degrees.
- Relative Humidity ± 5 %.
- DC Voltage $\pm 1,0$ %.
- AC Voltage $\pm 1,5$ %.
- Vibration 10 %.
- Vibration frequency 0,1 Hz.

The above values shall apply unless the test environment is otherwise controlled and the specification for the control of the test environment specifies the uncertainty for the parameter.

F.1.2 Measurement of transmitter

Table F.1.2 Maximum Test System Uncertainty for transmitter tests

Subclause	Maximum Test System Uncertainty	Derivation of Test System Uncertainty
5.2 Maximum Output Power	±0.7 dB	
5.3 Frequency Error	± 10 Hz	
5.4.1 Open loop power control in uplink	±1.0 dB comprising: SQRT(source_level_error ² + power_meas_error ²)	The uncertainty of this test is a combination of the downlink level setting error and the uplink power measurement which are uncorrelated. Formula = SQRT(source_level_error ² + power_meas_error ²)
5.4.2 Inner loop power control in the uplink -1 dB One step	±[0.1] dB relative over a 1.5 dB range (1 dB and 0 dB step) ±0.15 dB relative over a 3.0 dB range (2 dB step) ±0.2 dB relative over a 4.5 dB range (3 dB step)	
5.4.2 Inner loop power control in the uplink -10 dB	±[0.3] dB relative over a 12 dB to 26 dB range	
5.4.3 Minimum Output Power	±1.0 dB	
5.4.4 Out-of-synchronisation handling of output power: $\frac{DPCCH - E_c}{I_{or}}$	±[0.43] dB	0.1 dB uncertainty in DPCCH ratio 0.3 dB uncertainty in Ior/loc based on power meter measurement after the combiner Overall error is the sum of the loc/Ior ratio error and the DPCCH Ec/Ior ratio. The absolute error of the AWGN loc is not important but is specified as 1.0 dB
5.4.4 Out-of-synchronisation handling of output power: transmit ON/OFF time	[0] ms	
5.5.1 Transmit ON/OFF Power: UE minimum output power	±1.0 dB	(Static off power case)
5.5.2 Transmit ON/OFF Power: transmit ON/OFF time mask	On power +0.7 dB – 1.0 dB Off power (dynamic case) TBD	Assume asymmetric meas error -1.0 dB / 0.7 dB comprising RSS of: -0.7 dB downlink error plus -0.7 dB meas error, and +0.7 dB for upper limit (assume UE won't go above 24 nominal).
5.6 Change of TFC: power control step size	±0.25 dB TBD	
5.6 Change of TFC: timing	TBD	
5.7 Power setting in uplink compressed mode:-UE output power	TBD Will be a subset of 5.4.2.	
5.8 Occupied Bandwidth	±100 kHz	Accuracy = ±3*RBW. Assume 30 kHz bandwidth.
5.9 Spectrum emission mask	±1.5 dB	
5.10 ACLR	5 MHz offset: ± 0.8 dB 10 MHz offset: ± 0.8 dB	

5.11 Spurious emissions	± 2.0 dB for UE and coexistence bands for results > -60 dBm ± 3.0 dB for results < -60 dBm Outside above: $f \leq 2.2$ GHz : ± 1.5 dB 2.2 GHz $< f \leq 4$ GHz : ± 2.0 dB $f > 4$ GHz : ± 4.0 dB	
5.12 Transmit Intermodulation	Will be based on BS, need to work out freq and level ranges. ± 2.2 dB	<p><u>CW Interferer error is 0.7 dB for the UE power RSS with 0.7 dB for CW setting = 1.0 dB</u></p> <p><u>Measurement error of intermod product is 0.7 dB for UE power RSS with 0.7 dB for relative = 1.0 dB</u></p> <p><u>Interferer has an effect of 2 times on the intermod product so overall test uncertainty is $2 * 1.0$ RSS with 1.0 = 2.2 dB.</u></p> <p><u>Apply half any excess test system uncertainty to increase the interferer level</u></p>
5.13.1 Transmit modulation: EVM	± 2.5 % (for single code)	
5.13.2 Transmit modulation: peak code domain error	± 1.0 dB	

F.1.3 Measurement of receiver

Table F.1.3 Maximum Test System Uncertainty for receiver tests

Subclause	Maximum Test System Uncertainty	<u>Derivation of Test System Uncertainty</u>
6.2 Reference sensitivity level	± 0.7 dB	
6.3 maximum input level:	<u>± 0.7 dB</u> TBD	<p><u>The critical parameter is the overall signal level and not the -19 dB DPCH Ec/Ior ratio.</u></p> <p><u>0.7 dB absolute error due to signal measurement</u></p> <p><u>DPCH Ec/Ior ratio error is <0.1 dB but is not important so is ignored</u></p>
6.4 Adjacent channel selectivity	± 1.1 dB	<p><u>Overall system uncertainty comprises three quantities:</u></p> <ol style="list-style-type: none"> <u>1. Wanted signal level error</u> <u>2. Interferer signal level error</u> <u>3. Additional impact of interferer ACLR</u> <p><u>Items 1 and 2 are assumed to be uncorrelated so can be root sum squared to provide the ratio error of the two signals. Assume for simplicity this ratio error is linearly added to the interferer ACLR.</u></p> <p><u>Test System uncertainty = SQRT (wanted_level_error² + interferer_level_error²) + ACLR effect.</u></p> <p><u>The ACLR effect is calculated by:(Formula to follow)</u></p> <p><u>(E.g. ACLR at 5 MHz of 51 dB gives additional error of .0765 dB. ACLR of 48 gives error of -0.15 dB.)</u></p>
6.5 Blocking characteristics	<p>Using ± 0.7 dB for signal and interferer as currently defined, and 68 dB ACLR @ 10 MHz.</p> <p>System error with f <15 MHz offset: ± 1.4 dB</p> <p>f ≥ 15 MHz offset and f_b ≤ 2.2 GHz: ± [1.0] dB</p> <p>2.2 GHz < f ≤ 4 GHz : ±[1.7] dB</p> <p>f > 4 GHz: ±[3.1] dB</p>	
6.6 Spurious Response	<p>f ≤ 2.2 GHz: ± 1.0 dB</p> <p>2.2 GHz < f ≤ 4 GHz : ±1.7 dB</p> <p>f > 4 GHz: ±3.1 dB</p>	

<p>6.7 Intermodulation Characteristics</p>	<p>±1.3 dB Assume ±0.7 dB for all signals. Overall uncertainty = ±[0.6] dB</p> <p>Needs further analysis</p>	<p>Similar issues to 7.4 ACS test.</p> <p><u>ETR028 says impact if the closer signal is twice that of the far signal. If both signals drop 1 dB, intermod product drops 2 dB.</u></p> <p><u>Formula =</u> $\sqrt{(2 \cdot CW_level_error)^2 + (mod_level_error)^2}$</p> <p><u>(Using CW interferer ±0.5 dB, modulated interferer ±0.5 dB, wanted signal ±0.7 dB) 1.3 dB!</u></p> <p><u>Broadband noise/ACLR not considered but may have impact.</u></p>
<p>6.8 Spurious emissions</p>	<p>± 3.0 dB for UE receive band (-78 dBm) Outside above: f ≤ 2.2 GHz : ± 2.0 dB (-57 dBm) 2.2 GHz < f ≤ 4 GHz : ± 2.0 dB (-47 dBm) f > 4 GHz : ± 4.0 dB (-47 dBm)</p>	

F.1.4 Performance requirement

Table F.1.4 Maximum Test System Uncertainty for Performance Requirements

Subclause	Maximum Test System Uncertainty	Derivation of Test System Uncertainty
7.2 Demodulation in Static Propagation Condition	<p>Need combination of the following three parameters</p> $\hat{I}_{or}/I_{oc} \quad \pm\{0.35\} \text{ dB}$ $I_{oc} \quad \pm 1.0\{0.7\} \text{ dB}$ $\frac{DPCH - E_c}{I_{or}} \quad \pm\{0.13\} \text{ dB}$	<p>0.1 dB uncertainty in <u>DPCH_Ec ratio</u></p> <p>0.3 dB uncertainty in <u>lor/loc based on power meter measurement after the combiner</u></p> <p>Overall error is the sum of the <u>loc/lor ratio error and the DPCH_Ec/lor ratio but is not RSS for simplicity. The absolute error of the AWGN loc is not important for any tests in section 7 but is specified as 1.0 dB.</u></p>
7.3 Demodulation of DCH in multipath Fading Propagation conditions	<p>Need combination of the following three parameters</p> $\hat{I}_{or}/I_{oc} \quad \pm\{0.56\} \text{ dB}$ $I_{oc} \quad \pm\{1.0\} \text{ dB}$ $\frac{DPCH - E_c}{I_{or}} \quad \pm\{0.13\} \text{ dB}$	<p>Worst case gain uncertainty due to the fader from the <u>calibrated static profile is ±0.5 dB</u></p> <p>In addition the same <u>±0.3 dB lor/loc ratio error as 7.2.</u></p> <p><u>These are uncorrelated so can be RSS.</u></p> <p><u>Overall error in lior/loc is $(0.5^2 + 0.3^2)^{0.5} = 0.6 \text{ dB}$</u></p>
7.4 Demodulation of DCH in Moving Propagation conditions	$\hat{I}_{or}/I_{oc} \quad \pm 0.6 \text{ dB}$ $I_{oc} \quad \pm 1.0 \text{ dB}$ $\frac{DPCH - E_c}{I_{or}} \quad \pm 0.1 \text{ dB As 7.3}$	<p>Same as 7.3</p>
7.5 Demodulation of DCH in Birth-Death Propagation conditions	$\hat{I}_{or}/I_{oc} \quad \pm 0.6 \text{ dB}$ $I_{oc} \quad \pm 1.0 \text{ dB}$ $\frac{DPCH - E_c}{I_{or}} \quad \pm 0.1 \text{ dB As 7.3}$	<p>Same as 7.3</p>
7.6.1 Demodulation of DCH in <u>Base Station open loop</u> Transmit diversity mode	$\hat{I}_{or}/I_{oc} \quad \pm 0.8 \text{ dB}$ $I_{oc} \quad \pm 1.0 \text{ dB}$ $\frac{DPCH - E_c}{I_{or}} \quad \pm 0.1 \text{ dB As 7.3}$	<p>Worst case gain uncertainty due to the fader from the <u>calibrated static profile is ±0.5 dB per output</u></p> <p>In addition the same <u>±0.3 dB lor/loc ratio error as 7.2.</u></p> <p><u>These are uncorrelated so can be RSS.</u></p> <p><u>Overall error in lior/loc is $(0.5^2 + 0.5^2 + 0.3^2)^{0.5} = 0.768 \text{ dB}$</u> <u>Round up to 0.8 dB</u></p>
<u>7.6.2 Demodulation of DCH in closed loop</u> Transmit diversity mode	$\hat{I}_{or}/I_{oc} \quad \pm 0.8 \text{ dB}$ $I_{oc} \quad \pm 1.0 \text{ dB}$ $\frac{DPCH - E_c}{I_{or}} \quad \pm 0.1 \text{ dB}$	<p>Same as 7.6.1</p>

<p><u>7.6.3. Demodulation of DCH in site selection diversity Transmission power control mode</u></p>	$\frac{\hat{I}_{or}}{I_{oc}} \pm 0.8 \text{ dB}$ $I_{oc} \pm 1.0 \text{ dB}$ $\frac{DPCH - E_c}{I_{or}} \pm 0.1 \text{ dB}$	<p>Same as 7.6.1</p>
<p><u>7.7.1 Demodulation in inter-cell soft Handover conditions</u></p>	$\frac{\hat{I}_{or}}{I_{oc}} \pm 0.8 \text{ dB}$ $I_{oc} \pm 1.0 \text{ dB}$ $\frac{DPCH - E_c}{I_{or}} \pm 0.1 \text{ dB As 7.3}$	<p>Same as 7.6.1</p>
<p><u>7.7.2 Combining of TPC commands Test 1</u></p>	$\frac{\hat{I}_{or}}{I_{oc}} \pm 0.3 \text{ dB}$ $I_{oc} \pm 1.0 \text{ dB}$ $\frac{DPCH - E_c}{I_{or}} \pm 0.1 \text{ dB}$	<p>Have two Ior1 and Ior2, and no AWGN. So error is only 0.3 dB</p> <p>Test is looking for changes in power – need to allow for relaxation in criteria for power step of probably 0.1 dB to 0.4 dB</p>
<p><u>7.7.2 Combining of TPC commands Test 2</u></p>	$\frac{\hat{I}_{or}}{I_{oc}} \pm 0.8 \text{ dB}$ $I_{oc} \pm 1.0 \text{ dB}$ $\frac{DPCH - E_c}{I_{or}} \pm 0.1 \text{ dB}$	<p>Same as 7.6.1</p>
<p><u>7.8.1 Power control in downlink constant BLER target</u></p>	<p>As 7.3</p> $\frac{\hat{I}_{or}}{I_{oc}} \pm 0.6 \text{ dB}$ $I_{oc} \pm 1.0 \text{ dB}$ $\frac{DPCH - E_c}{I_{or}} \pm 0.1 \text{ dB}$	<p>Same as 7.3</p>
<p><u>7.8.2. Power control in downlink initial convergence</u></p>	$\frac{\hat{I}_{or}}{I_{oc}} \pm 0.6 \text{ dB}$ $I_{oc} \pm 1.0 \text{ dB}$ $\frac{DPCH - E_c}{I_{or}} \pm 0.1 \text{ dB}$	<p>Same as 7.3</p>
<p><u>7.8.3. Power control in downlink: wind up effects</u></p>	$\frac{\hat{I}_{or}}{I_{oc}} \pm 0.6 \text{ dB}$ $I_{oc} \pm 1.0 \text{ dB}$ $\frac{DPCH - E_c}{I_{or}} \pm 0.1 \text{ dB}$	<p>Same as 7.3</p>
<p>7.9 Downlink compressed mode</p>	$\frac{\hat{I}_{or}}{I_{oc}} \pm 0.6 \text{ dB}$ $I_{oc} \pm 1.0 \text{ dB}$ $\frac{DPCH - E_c}{I_{or}} \pm 0.1 \text{ dB As 7.3}$	<p>Same as 7.3</p>
<p><u>7.10 Blind transport format detection Tests 1, 2, 3</u></p>	$\frac{\hat{I}_{or}}{I_{oc}} \pm 0.3 \text{ dB}$ $I_{oc} \pm 1.0 \text{ dB}$ $\frac{DPCH - E_c}{I_{or}} \pm 0.1 \text{ dB}$ <p>As 7.3</p>	<p>Same as 7.2</p>

7.10 Blind transport format detection Tests 4, 5, 6	$\frac{\hat{I}_{or}}{I_{oc}} \quad \underline{\quad \quad \quad} \quad \pm 0.6 \text{ dB}$ $\frac{I_{oc}}{\quad \quad \quad} \quad \underline{\quad \quad \quad} \quad \pm 1.0 \text{ dB}$ $\frac{DPCH - E_c}{I_{or}} \quad \underline{\quad \quad \quad} \quad \pm 0.1 \text{ dB}$	Same as 7.3
--	---	-----------------------------

F.1.5 Requirements for support of RRM

TBD

F.2 Test Tolerances (This subclause is informative)

The Test Tolerances defined in this subclause have been used to relax the Minimum Requirements in this specification to derive the Test Requirements.

The Test Tolerances are derived from Test System uncertainties, regulatory requirements and criticality to system performance. As a result, the Test Tolerances may sometimes be set to zero.

The test tolerances should not be modified for any reason e.g. to take account of commonly known test system errors (such as mismatch, cable loss, etc.).

F.2.1 Transmitter

Table F.2.1 Test Tolerances for transmitter tests.

Subclause	Test Tolerance
5.2 Maximum Output Power	0.7 dB
5.3 Frequency error	10 Hz
5.4.1 Open loop power control in uplink	1.0 dB
5.4.2 Inner loop power control in the uplink -4 dB One step	0.1 dB (1 dB and 0 dB step) 0.15 dB (2 dB step) 0.2 dB (3 dB step)
5.4.2 Inner loop power control in the uplink -40 dB 7 and 10 steps	[0.3] dB
5.4.3 Minimum Output Power	1.0 dB
5.4.4 Out-of-synchronisation handling of output power: $\frac{DPCCCH - E_c}{I_{or}}$	[0.43] dB
5.4.4 Out-of-synchronisation handling of output power: transmit ON/OFF time	0 ms
5.5.1 Transmit OFF power	1.0 dB
5.6 Change of TFC: power control step size	0.25 dB
5.6 Change of TFC: timing	
5.7 Power setting in uplink compressed mode: -UE output power	See subset of 5.4.2
5.8 Occupied Bandwidth	0 kHz
5.9 Spectrum emission mask	1.5 dB
5.10 ACLR	0.8 dB
5.11 Spurious emissions	0 dB
5.12 Transmit Intermodulation	0 dB
5.13.1 Transmit modulation: EVM	0%
5.13.2 Transmit modulation: peak code domain error	1.0 dB

F.2.2 Receiver

Table F.2.2 Test Tolerances for receiver tests.

Subclause	Test Tolerance
6.2 Reference sensitivity level	0.7 dB
6.3 Maximum input level:	<u>0.7 dB</u>
6.4 Adjacent channel selectivity	0 dB
6.5 Blocking characteristics	0 dB
6.6 Spurious Response	0 dB
6.7 Intermodulation Characteristics	0 dB
6.8 Spurious emissions	0 dB

F.2.3 Performance requirements

Table F.2.3 Test Tolerances for Performance Requirements.

Subclause	Test Tolerance
7.2 Demodulation in Static Propagation Condition	<u>0.3 dB for loc/lor</u> <u>0.1 dB for DPCH Ec/lor</u>
7.3 Demodulation of DCH in multipath Fading Propagation conditions	<u>0.6 dB for loc/lor</u> <u>0.1 dB for DPCH Ec/lor</u>
7.4 Demodulation of DCH in Moving Propagation conditions	<u>0.6 dB for loc/lor</u> <u>0.1 dB for DPCH Ec/lor</u>
7.5 Demodulation of DCH in Birth-Death Propagation conditions	<u>0.6 dB for loc/lor</u> <u>0.1 dB for DPCH Ec/lor</u>
7.6.1 Demodulation of DCH in Base Station <u>open loop</u> Transmit diversity mode	<u>0.8 dB for loc/lor</u> <u>0.1 dB for DPCH Ec/lor</u>
7.6.2 Demodulation of DCH in closed loop Transmit diversity mode	<u>0.8 dB for loc/lor</u> <u>0.1 dB for DPCH Ec/lor</u>
7.6.3. Demodulation of DCH in site selection diversity Transmission power control mode	<u>0.8 dB for loc/lor</u> <u>0.1 dB for DPCH Ec/lor</u>
7.7.1 Demodulation in <u>inter-cell soft</u> Handover conditions	<u>0.8 dB for loc/lor</u> <u>0.1 dB for DPCH Ec/lor</u>
7.7.2 Combining of TPC commands Test 1	<u>0.8 dB for loc/lor</u> <u>0.1 dB for DPCH Ec/lor</u>
7.7.2 Combining of TPC commands Test 8	<u>0.3 dB for loc/lor</u> <u>0.1 dB for DPCH Ec/lor</u>
7.8.1 Power control in downlink <u>constant BLER target</u>	<u>0.6 dB for loc/lor</u> <u>0.1 dB for DPCH Ec/lor</u>
7.8.2. Power control in downlink <u>initial convergence</u>	<u>0.6 dB for loc/lor</u> <u>0.1 dB for DPCH Ec/lor</u>
7.8.3. Power control in downlink: <u>wind up effects</u>	<u>0.6 dB for loc/lor</u> <u>0.1 dB for DPCH Ec/lor</u>
7.9 Downlink compressed mode	<u>0.6 dB for loc/lor</u> <u>0.1 dB for DPCH Ec/lor</u>
7.10 Blind transport format detection Tests 1, 2, 3	<u>0.3 dB for loc/lor</u> <u>0.1 dB for DPCH Ec/lor</u>
7.10 Blind transport format detection Tests 4, 5, 6	<u>0.6 dB for loc/lor</u> <u>0.1 dB for DPCH Ec/lor</u>

F.2.4 Requirements for support of RRM

TBD

F.3 Interpretation of measurement results

The measurement results returned by the Test System are compared \pm without any modification \pm against the Test Requirements as defined by the shared risk principle.

The Shared Risk principle is defined in ETR 273 Part 1 sub-part 2 section 6.5.

The actual measurement uncertainty of the Test System for the measurement of each parameter shall be included in the test report.

The recorded value for the Test System uncertainty shall be, for each measurement, equal to or lower than the appropriate figure in subclause F.1 of this specification.

If the Test System for a test is known to have a measurement uncertainty greater than that specified in subclause F.1, it is still permitted to use this apparatus provided that an adjustment is made value as follows.

Any additional uncertainty in the Test System over and above that specified in subclause F.1 shall be used to tighten the Test Requirement – making the test harder to pass. (For some tests e.g. receiver tests, this may require modification of stimulus signals). This procedure will ensure that a Test System not compliant with subclause F.1 does not increase the chance of passing a device under test where that device would otherwise have failed the test if a Test System compliant with subclause F.1 had been used.

F.4 Derivation of Test Requirements (This subclause is informative)

The Test Requirements in this specification have been calculated by relaxing the Minimum Requirements of the core specification using the Test Tolerances defined in subclause F.2. When the Test Tolerance is zero, the Test Requirement will be the same as the Minimum Requirement. When the Test Tolerance is non-zero, the Test Requirements will differ from the Minimum Requirements, and the formula used for this relaxation is given in table F.4.

Table F.4.1 Derivation of Test Requirements (Transmitter tests)

Test	Minimum Requirement in TS 25.101	Test Tolerance (TT)	Test Requirement in TS 34.121
5.2 Maximum Output Power	Power class 1 (33 dBm) Tolerance = +1/-3 dB Power class 2 (27 dBm) Tolerance = +1/-3 dB Power class 3 (24 dBm) Tolerance = +1/-3 dB Power class 4 (21 dBm) Tolerance = ±2 dB	0.7 dB	Formula: Upper Tolerance limit + TT Lower Tolerance limit – TT For power classes 1-3: Upper Tolerance limit = +1.7 dB Lower Tolerance limit = -3.7 dB For power class 4: Upper Tolerance limit = +2.7 dB Lower Tolerance limit = -2.7 dB
5.3 Frequency Error	The UE modulated carrier frequency shall be accurate to within ±0.1 ppm compared to the carrier frequency received from the Node B.	10 Hz	Formula: modulated carrier frequency error + TT modulated carrier frequency error = ±(0.1 ppm + 10 Hz).
5.4.1 Open loop power control in the uplink	Open loop power control tolerance ±9 dB (Normal) Open loop power control tolerance ±12 dB (Normal)	1.0 dB	Formula: Upper Tolerance limit + TT Lower Tolerance limit – TT For Normal conditions: Upper Tolerance limit = +10 dB Lower Tolerance limit = -10 dB For Extreme conditions: Upper Tolerance limit = +13 dB Lower Tolerance limit = -13 dB
5.4.2 Inner loop power control in uplink	See table 5.4.2.1 and 5.4.2.2	0.25dB 0.15 dB 0.2 dB [0.3 dB]	Formula: Upper Tolerance limit + TT Lower Tolerance limit – TT
5.4.3 Minimum Output Power	UE minimum transmit power shall be less than –50 dBm	1.0 dB	Formula: UE minimum transmit power + TT UE minimum transmit power = –49 dBm

<p>5.4.4 Out-of-synchronisation handling of output power:</p>	<p>$\frac{DPCCH_E_c}{I_{or}}$ levels AB: -22 dB BD: -28 dB DE: -24 dB EF: -18 dB transmit ON/OFF time 200ms</p> <p>$\frac{DPDCH_E_c}{I_{or}} = -16.6$ dB</p> <p>$I_{oc} - 60$ dBm</p> <p>lor/loc = - 1 dB</p>	<p>{0.43} dB for $\frac{DPCCH_E_c}{I_{or}}$</p> <p>0 ms for timing measurement</p>	<p>Formulas: Ratio between A and B + TT Ratio between B and D = TT Ratio between D and E = TT Ratio between E and F + TT transmit ON/OFF time + TT timing</p> <p>$\frac{DPDCH_E_c}{I_{or}} = -16.6$ dB</p> <p>$I_{oc} - 60$ dBm</p> <p>lor/loc = - 1 dB</p> <p>$\frac{DPCCH_E_c}{I_{or}}$ levels: AB: -21.62 + {0.3} dB BD: -28.4 - {0.3} dB DE: -24.4 - {0.3} dB EF: -17.68 + {0.3} dB</p> <p>transmit ON/OFF time 200ms timing Uncertainty of OFF power measurement is handled by Transmit OFF power test and uncertainty of ON power measurement is handled by Minimum output power test.</p>
<p>5.5.1 Transmit OFF power</p>	<p>Transmit OFF power shall be less than -56 dBm</p>	<p>1.0 dB</p>	<p>Formula: Transmit OFF power + TT Transmit OFF power = -55dBm.</p>
<p>5.6 Change of TFC: <u>power control step size</u></p>	<p><u>TFC step size = -5 to -9 dB</u></p>	<p><u>0.25 dB</u></p>	<p>Formula: <u>Upper Tolerance limit + TT</u> <u>Lower Tolerance limit - TT</u></p> <p><u>Upper limit = -4.75 dB</u> <u>Lower limit = -9.25 dB</u></p>
<p>5.7 Power setting in <u>uplink compressed mode</u></p>	<p><u>Various</u></p>	<p><u>TBD</u> <u>(Subset of 5.4.2)</u></p>	<p><u>TBD</u></p>
<p>5.8 Occupied Bandwidth</p>	<p>The occupied channel bandwidth shall be less than 5 MHz based on a chip rate of 3.84 Mcps.</p>	<p>0 kHz</p>	<p>Formula: occupied channel bandwidth: + TT</p> <p>occupied channel bandwidth = 5.0 MHz</p>
<p>5.9 Spectrum emission mask</p>	<p>Minimum requirement defined in TS25.101 Table 6.10. The lower limit shall be -50 dBm / 3.84 MHz or which ever is higher.</p>	<p>1.5 dB</p>	<p>Formula: Minimum requirement + TT Lower limit + TT Add 1.5 to Minimum requirement entries in TS25.101 Table 6.10 The lower limit shall be -48.5 dBm / 3.84 MHz or which ever is higher.</p>
<p>5.10 Adjacent Channel Leakage Power Ratio (ACLR)</p>	<p>Power Classes 3 and 4: UE channel +5 MHz or -5 MHz, ACLR limit: 33 dB UE channel +10 MHz or -10 MHz, ACLR limit: 43 dB</p>	<p>0.8 dB</p>	<p>Formula: ACLR limit - TT Power Classes 3 and 4: UE channel +5 MHz or -5 MHz, ACLR limit: 32.2 dB UE channel +10 MHz or -10 MHz, ACLR limit: 42.2 dB</p>

5.11 Spurious Emissions			Formula: Minimum Requirement+ TT Add zero to all the values of Minimum Requirements in table 5.11.1a and 5.11.1b.		
	Frequency Band	Minimum Requirement		Frequency Band	Minimum Requirement
	9 kHz ≤ f < 150 kHz	-36dBm /1kHz	0 dB	9kHz ≤ f < 1GHz	-36dBm /1kHz
	150 kHz ≤ f < 30 MHz	-36dBm /10kHz	0 dB	150 kHz ≤ f < 30 MHz	-36dBm /10kHz
	30 MHz ≤ f < 1000 MHz	-36dBm /100kHz	0 dB	30 MHz ≤ f < 1000 MHz	-36dBm /100kHz
	1 GHz ≤ f < 12.75 GHz	-30dBm /1MHz	0 dB	1 GHz ≤ f < 2.2 GHz	-30dBm /1MHz
			0 dB	2.2 GHz ≤ f < 4 GHz	-30dBm /1MHz
			0 dB	4 GHz ≤ f < 12.75 GHz	-30dBm /1MHz
	1893.5 MHz < f < 1919.6 MHz	-41dBm /300kHz	0 dB	1893.5 MHz < f < 1919.6 MHz	-41dBm /300kHz
	925 MHz ≤ f ≤ 935 MHz	-67dBm /100kHz	0 dB	925 MHz ≤ f ≤ 935 MHz	-67dBm /100kHz
935 MHz < f ≤ 960 MHz	-79dBm /100kHz	0 dB	935 MHz < f ≤ 960 MHz	-79dBm /100kHz	
1805 MHz ≤ f ≤ 1880 MHz	-71dBm /100kHz	0 dB	1805 MHz ≤ f ≤ 1880 MHz	-71dBm /100kHz	
5.12 Transmit Intermodulation	Intermodulation Product 5MHz -31 dBc 10MHz -41 dBc <u>CW Interferer level = -40 dBc</u>		<u>0 dB</u>	Formula: <u>Intermodulation Product + TT</u> <u>Intermodulation Product</u> <u>5MHz -31 + TT dBc</u> <u>10MHz -41 +TT dBc</u> <u>CW interferer level - TT/2</u> <u>Intermod Products limits remain unchanged.</u> <u>CW interferer level = -40 dBc</u>	
5.13.1 Transmit modulation: EVM	The measured EVM shall not exceed 17.5%.		0%	Formula: EVM limit + TT EVM limit = 17.5 %	
5.13.2 Transmit modulation: peak code domain error	The measured Peak code domain error shall not exceed -15 dB.		1.0 dB	Formula: Peak code domain error + TT Peak code domain error = -14 dB	

Table F.4.2 Derivation of Test Requirements (Receiver tests)

Test	Minimum Requirement in TS 25.101	Test Tolerance (TT)	Test Requirement in TS 34.121
6.2 Reference sensitivity level	$\hat{I}_{or} = -106.7 \text{ dBm} / 3.84 \text{ MHz}$ DPCH_Ec = -117 dBm / 3.84 MHz BER limit = 0.001	0.7 dB	Formula: $\hat{I}_{or} + TT$ DPCH_Ec + TT BER limit unchanged $\hat{I}_{or} = -106 \text{ dBm} / 3.84 \text{ MHz}$ DPCH_Ec = -116.3 dBm / 3.84 MHz
<u>6.3 Maximum input level</u>	<u>-25 dBm Ior</u> <u>-19 dBc DPCH Ec/Ior</u>	<u>0.7 dB</u>	<u>Formula: Ior-TT</u> <u>Ior = -25.7 dBm</u>

6.4 Adjacent Channel Selectivity	$\hat{I}_{or} = -92.7 \text{ dBm} / 3.84 \text{ MHz}$ DPCH_Ec = $-103 \text{ dBm} / 3.84 \text{ MHz}$ Ioac (modulated) = $-52 \text{ dBm} / 3.84 \text{ MHz}$ BER limit = 0.001	0 dB	Formula: \hat{I}_{or} unchanged DPCH_Ec unchanged Ioac – TT BER limit unchanged Ioac = $-52 \text{ dBm} / 3.84 \text{ MHz}$		
6.5 Blocking Characteristics	See Table 6.5.3 and 6.5.4. in TS34.121 BER limit = 0.001	0 dB	Formula: $I_{\text{blocking}}(\text{modulated}) - TT$ (dBm/3.84MHz) $I_{\text{blocking}}(\text{CW}) - TT$ (dBm) BER limit unchanged		
6.6 Spurious Response	Iblocking(CW) -44 dBm Fuw: Spurious response frequencies BER limit = 0.001	0 dB	Formula: $I_{\text{blocking}}(\text{CW}) - TT$ (dBm) Fuw unchanged BER limit unchanged $I_{\text{blocking}}(\text{CW}) = -44 \text{ dBm}$		
6.7 Intermodulation Characteristics	Iouw1 (CW) -46 dBm Iouw2 (modulated) $-46 \text{ dBm} / 3.84 \text{ MHz}$ Fuw1 (offset) 10 MHz Fuw2 (offset) 20 MHz <u>$I_{or} = -103.7 \text{ dBm} / 3.84 \text{ MHz}$</u> <u>DPCH Ec = $-114 \text{ dBm} / 3.84$</u> BER limit = 0.001	0 dB	Formula: TBD <u>$I_{or} + TT$</u> <u>DPCH Ec + TT</u> <u>Iouw1 level unchanged</u> <u>Iouw2 level unchanged</u> <u>BER limit unchanged.</u> <u>$I_{or} = -114 \text{ dBm}$</u> BER limit unchanged. <u>= 0.001</u>		
6.8 Spurious Emissions			Formula: Maximum level+ TT Add zero to all the values of Maximum Level in table 6.8.1.		
	Frequency Band	Maximum level	Frequency Band	Maximum level	
	9kHz $\leq f < 1\text{GHz}$	$-57\text{dBm} / 100\text{kHz}$	9kHz $\leq f < 1\text{GHz}$	$-57\text{dBm} / 100\text{kHz}$	
	1GHz $\leq f \leq 12.75\text{GHz}$	$-47\text{dBm} / 1\text{MHz}$	0 dB	1GHz $\leq f \leq 2.2\text{GHz}$	$-47\text{dBm} / 1\text{MHz}$
0 dB			2.2GHz $< f \leq 4\text{GHz}$	$-47\text{dBm} / 1\text{MHz}$	
0 dB			4GHz $< f \leq 12.75\text{GHz}$	$-47\text{dBm} / 1\text{MHz}$	
	1920MHz $\leq f \leq 1980\text{MHz}$	$-60\text{dBm} / 3.84\text{MHz}$	0 dB	1920MHz $\leq f \leq 1980\text{MHz}$	$-60\text{dBm} / 3.84\text{MHz}$
	2110MHz $\leq f \leq 2170\text{MHz}$	$-60\text{dBm} / 3.84\text{MHz}$	0 dB	2110MHz $\leq f \leq 2170\text{MHz}$	$-60\text{dBm} / 3.84\text{MHz}$

Table F.4.3 Derivation of Test Requirements (Performance tests)

Test	Minimum Requirement in TS 25.101	Test Tolerance (TT)	Test Requirement in TS 34.121
<u>7.2 Demodulation of DPCH in static conditions</u>	$\frac{DPCH_E_c}{I_{or}} \text{ -5.5 to -16.6}$ $I_{oc} = -60 \text{ dBm}$ $\text{lor/loc} = -1 \text{ dB}$	$\frac{DPCH_E_c}{I_{or}}$ 0.1 dB for $\frac{DPCH_E_c}{I_{or}}$ 0.3 dB for loc/lor	Formulas: $\frac{DPCH_E_c}{I_{or}} = \text{ratio} + TT$ $\text{lor/loc} + \text{ratio} + TT$ $I_{oc} \text{ unchanged}$ $\text{lor/loc} = -0.7 \text{ dB}$ $\frac{DPCH_E_c}{I_{or}} \text{ -5.4 to -16.5 dB:}$
<u>7.3 Demodulation of DPCH in multi-path fading propagation conditions</u>	$\frac{DPCH_E_c}{I_{or}} \text{ -2.2 to -15.0}$ $I_{oc} = -60 \text{ dBm}$ $\text{lor/loc} = 9 \text{ dB to -3 dB}$	$\frac{DPCH_E_c}{I_{or}}$ 0.1 dB for $\frac{DPCH_E_c}{I_{or}}$ 0.6 dB for loc/lor	Formulas: $\frac{DPCH_E_c}{I_{or}} = \text{ratio} + TT$ $\text{lor/loc} + \text{ratio} + TT$ $I_{oc} \text{ unchanged}$ $\text{lor/loc} = 9.6 \text{ to -2.4 dB}$ $\frac{DPCH_E_c}{I_{or}} \text{ -2.1 to -14.9 dB:}$
<u>7.4 Demodulation of DPCH in moving propagation conditions</u>	$\frac{DPCH_E_c}{I_{or}} \text{ -2.2 to -15.0}$ $I_{oc} = -60 \text{ dBm}$ $\text{lor/loc} = 9 \text{ dB to -3 dB}$	$\frac{DPCH_E_c}{I_{or}}$ 0.1 dB for $\frac{DPCH_E_c}{I_{or}}$ 0.6 dB for loc/lor	Formulas: $\frac{DPCH_E_c}{I_{or}} = \text{ratio} + TT$ $\text{lor/loc} + \text{ratio} + TT$ $I_{oc} \text{ unchanged}$ $\text{lor/loc} = 9.6 \text{ to -2.4 dB}$ $\frac{DPCH_E_c}{I_{or}} \text{ -2.1 to -14.9 dB:}$
<u>7.5 Demodulation of DPCH birth-death propagation conditions</u>	$\frac{DPCH_E_c}{I_{or}} \text{ -2.2 to -15.0}$ $I_{oc} = -60 \text{ dBm}$ $\text{lor/loc} = 9 \text{ dB to -3 dB}$	$\frac{DPCH_E_c}{I_{or}}$ 0.1 dB for $\frac{DPCH_E_c}{I_{or}}$ 0.6 dB for loc/lor	Formulas: $\frac{DPCH_E_c}{I_{or}} = \text{ratio} + TT$ $\text{lor/loc} + \text{ratio} + TT$ $I_{oc} \text{ unchanged}$ $\text{lor/loc} = 9.6 \text{ to -2.4 dB}$ $\frac{DPCH_E_c}{I_{or}} \text{ -2.1 to -14.9 dB:}$

7.6.1 Demodulation of DPCH in transmit diversity propagation conditions	$\frac{DPCH_E_c}{I_{or}} \text{ -2.2 to -15.0}$ $I_{oc} = -60 \text{ dBm}$ $\text{lor/loc} = 9 \text{ dB to -3 dB}$	0.1 dB for $\frac{DPCH_E_c}{I_{or}}$ 0.8 dB for $\frac{\text{lor}}{\text{loc}}$	Formulas: $\frac{DPCH_E_c}{I_{or}} = \text{ratio} + TT$ $\text{lor/loc} + \text{ratio} + TT$ $I_{oc} \text{ unchanged}$ $\text{lor/loc} = 9.6 \text{ to -2.4 dB}$ $\frac{DPCH_E_c}{I_{or}} \text{ -2.1 to -14.9 dB:}$
7.6.2 Demodulation of DCH in closed loop Transmit diversity mode			To be completed
7.6.3. Demodulation of DCH in site selection diversity Transmission power control mode			To be completed
7.7.1 Demodulation in inter-cell soft Handover			To be completed
7.7.2 Combining of TPC commands Test 1			To be completed
7.7.2 Combining of TPC commands Test 2			To be completed
7.7.2 Combining of TPC commands Test 2			To be completed
7.8.1 Power control in downlink constant BLER target			To be completed
7.8.2. Power control in downlink initial convergence			To be completed
7.8.3. Power control in downlink: wind up effects			To be completed
7.9 Downlink compressed mode			To be completed
7.10 Blind transport format detection Tests 1, 2, 3			To be completed
7.10 Blind transport format detection Tests 4, 5, 6			To be completed

F.5 Acceptable uncertainty of Test Equipment (This subclause is informative)

This informative subclause specifies the critical parameters of the components of an overall Test System (e.g. Signal generators, Signal Analysers etc.) which are necessary when assembling a Test System that complies with subclause F.1 Acceptable Uncertainty of Test System. These Test Equipment parameters are fundamental to the accuracy of the overall Test System and are unlikely to be improved upon through System Calibration.

F.5.1 Transmitter measurements

Table F.5.1 Equipment accuracy for transmitter measurements

Test	Equipment accuracy	Test conditions
5.2 Maximum Output Power	Not critical	21 to 2833 dBm
5.3 Frequency error	± 10 Hz	0 to 500 Hz.
5.4.1 Open loop power control in uplink	Not critical	-43.7 dBm to 284 dBm
5.4.2 Inner loop power control in the uplink – 4 dB single step	± 0.1 dB relative over a 1.5 dB range ± 0.15 dB relative over a 3.0 range ± 0.2 dB relative over a 4.5 dB range	+ 284 dBm to -50 dBm
5.4.2 Inner loop power control in the uplink – 10 steps -dB	± 0.3 dB relative over a 4226 dB range	+ 284 dBm to -50 dBm
5.4.3 Minimum Output Power	Not critical	
5.4.4 Out-of-synchronisation handling of output power: $\frac{DPCCH - E_c}{I_{or}}$	± 0.1 dB uncertainty in DPCCH E_c/I_{or} ratio	Ratio from -16.6 dB to -28 dB
5.4.4 Out-of-synchronisation handling of output power: transmit ON/OFF time		
5.5.1 Transmit ON/OFF Power: UE transmit OFF power	<u>Not critical</u>	-56 dBm (static power)
5.5.2 Transmit ON/OFF Power: transmit ON/OFF time mask	<u>TBD</u>	-56 dBm (dynamic power)
5.6 Change of TFC: power control step size	± 0.25 dB relative over a 9 dB range	+ 28 dBm to -50 dBm
5.6 Change of TFC: timing		
5.7 Power setting in uplink compressed mode:-UE output power	<u>Subset of 5.4.2</u>	+ 28 dBm to -50 dBm
5.8 Occupied Bandwidth	±100 kHz	For results between 4 and 6 MHz?
5.9 Spectrum emission mask	Not critical	P_Max Accuracy applies ±5 dB either side of UE requirements
5.10 ACLR	5 MHz offset ± 0.8 dB 10 MHz offset ± 0.8 dB	P_Max 21 to 28 dBm at 5 MHz offset for results between 40 dB and 50 dB. P_Max 28 dBm at 10 MHz offset for results between 45 dB and 55 dB.
5.11 Spurious emissions	Not critical	P_Max 21 to 28 dBm
5.12 Transmit Intermodulation	Not critical	P_Max 21 to 28 dBm
5.13.1 Transmit modulation: EVM	±2.5 % (for single code)	2833 dBm to -210 dBm
5.13.2 Transmit modulation: peak code domain error	±1.0dB	For readings between -10 dB to -20 dB.

F.5.2 Receiver measurements

Table F.5.2: Equipment accuracy for receiver measurements

Subclause	Equipment accuracy	Test conditions
6.2 Reference sensitivity level	Not critical	
6.3 Maximum input level:	Not critical	
6.4 Adjacent channel selectivity	Not critical	
6.5 Blocking characteristics	Not critical	
6.6 Spurious Response	Not critical	
6.7 Intermod Characteristics	Not critical	
6.8 Spurious emissions	Not critical	

F.5.3 Performance measurements

Table G.3: Equipment accuracy for performance measurements

Subclause	Equipment accuracy	Test conditions
<u>7.2 to 7.10</u>	$\frac{DPCH_E_c}{I_{or}} \pm 0.1 \text{ dB}$	<u>-2.2 to -18.9 dB</u>
7.2 Demodulation in Static Propagation Condition	Not critical	
7.3 Demodulation of DCH in multipath Fading Propagation conditions	Not critical	
7.4 Demodulation of DCH in Moving Propagation conditions	Not critical	
7.5 Demodulation of DCH in Birth-Death Propagation conditions	Not critical	
7.6 Demodulation of DCH in Base Station Transmit diversity	Not critical	
7.7 Demodulation in Handover conditions	Not critical	
7.8 Power control in downlink	Not critical	
7.9 Downlink compressed mode	Not critical	
7.10 Blind transport format detection	Not critical	

F.6 General rules for statistical testing

[TBD]

CHANGE REQUEST

⌘ **34.121** **CR 084** ⌘ rev **-** ⌘ Current version: **3.4.0** ⌘

For **HELP** on using this form, see bottom of this page or look at the pop-up text over the ⌘ symbols.

Proposed change affects: ⌘ (U)SIM ME/UE Radio Access Network Core Network

Title:	⌘ Measurement accuracy of CPICH RSCP		
Source:	⌘ T1/RF		
Work item code:	⌘	Date:	⌘ 2001-5-14
Category:	⌘ F	Release:	⌘ R99
	<i>Use <u>one</u> of the following categories:</i> F (essential correction) A (corresponds to a correction in an earlier release) B (Addition of feature), C (Functional modification of feature) D (Editorial modification) Detailed explanations of the above categories can be found in 3GPP TR 21.900.		<i>Use <u>one</u> of the following releases:</i> 2 (GSM Phase 2) R96 (Release 1996) R97 (Release 1997) R98 (Release 1998) R99 (Release 1999) REL-4 (Release 4) REL-5 (Release 5)

Reason for change:	⌘ Description for test case is missing in TS34.121
Summary of change:	⌘ Test case description is proposed for intra and inter frequency measurement accuracy of CPICH RSCP. Also test conditions are proposed in this CR.
Consequences if not approved:	⌘ The test description is missing in TS 34.121 for measurement accuracy of CPICH RSCP requirement in TS 25.133.

Clauses affected:	⌘ 8.7.1	
Other specs Affected:	<input type="checkbox"/> Other core specifications ⌘ <input type="checkbox"/> Test specifications ⌘ <input type="checkbox"/> O&M Specifications ⌘	⌘
Other comments:	⌘	

How to create CRs using this form:

Comprehensive information and tips about how to create CRs can be found at: http://www.3gpp.org/3G_Specs/CRs.htm. Below is a brief summary:

- 1) Fill out the above form. The symbols above marked ⌘ contain pop-up help information about the field that they are closest to.
- 2) Obtain the latest version for the release of the specification to which the change is proposed. Use the MS Word "revision marks" feature (also known as "track changes") when making the changes. All 3GPP specifications can be downloaded from the 3GPP server under <ftp://www.3gpp.org/specs/> For the latest version, look for the directory name with the latest date e.g. 2000-09 contains the specifications resulting from the September 2000 TSG meetings.
- 3) With "track changes" disabled, paste the entire CR form (use CTRL-A to select it) into the specification just in front of the clause containing the first piece of changed text. Delete those parts of the specification which are not relevant to the change request.

8.7 Measurements Performance Requirements

8.7.1 CPICH RSCP

8.7.1.1 Intra frequency measurements accuracy

8.7.1.1.1 8.7.1.1.1 Absolute accuracy requirement

8.7.1.1.1.1 Definition and applicability

The absolute accuracy of CPICH RSCP is defined as the CPICH RSCP measured from one cell compared to the CPICH E_c power from same cell.

The requirements and this test apply to all types of UTRA for the FDD UE.

8.7.1.1.1.2 Minimum Requirements

The accuracy requirements in Table 8.7.1.1.1 are valid under the following conditions:

- CPICH RSCP1 \geq -114 dBm.

$$- \frac{I_o}{\left(\hat{I}_{or}\right)_{in \text{ dB}}} - \left(\frac{CPICH - E_c}{I_{or}} \right)_{in \text{ dB}} \leq 20dB$$

Table 8.7.1.1.1: CPICH RSCP Intra frequency absolute accuracy

Parameter	Unit	Accuracy [dB]		Conditions
		Normal condition	Extreme condition	Io [dBm]
CPICH RSCP	dBm	± 6	± 9	-94...-70
	dBm	± 8	± 11	-94...-50

The normative reference for this requirement is [2] TS 25.133 subclause 9.1.1.1 and A.9.1.1.2.

8.7.1.1.1.3 Test purpose

The purpose of this test is to verify that the CPICH RSCP absolute measurement accuracy is within the specified limits in subclause 8.7.1.1.2. This measurement is for handover evaluation, DL open loop power control, UL open loop control and for the calculation of pathloss.

8.7.1.1.1.4 Method of test

8.7.1.1.1.4.1 Initial conditions

Test environment: normal, TL/VL, TL/VH, TH/VL, TH/VH; see subclauses G.2.1 and G.2.2.

Frequencies to be tested: mid range; see subclause G.2.4.

Table 8.7.1.1.2 defines the limits of signal strengths and code powers, when the requirements are applicable. When verifying the CPICH RSCP intra frequency absolute accuracy requirement only cell 1 in Table 8.7.1.1.2 shall be present.

Table 8.7.1.1.1.2: CPICH RSCP Intra frequency test parameters

Parameter	Unit	Cell 1	Cell 2
UTRA RF Channel number		Channel 1	Channel 1
<i>CPICH Ec/lor</i>	dB	-10	-10
<i>PCCPCH Ec/lor</i>	dB	-12	-12
<i>SCH Ec/lor</i>	dB	-12	-12
<i>PICH Ec/lor</i>	dB	-15	-15
<i>DPCH Ec/lor</i>	dB	-15	-15
<i>OCNS</i>	dB	-1.11	-1.11
<i>lor/loc</i>	dB	10.5	10.5
<i>loc</i>	dBm/ 3.84 MHz	<i>lo - 13.7 dB = loc,</i> Note 1	<i>lo - 13.7 dB = loc,</i> Note 1
<i>Range 1: lo</i>		-94...-70	-94...-70
<i>Range 2: lo</i>	dBm	-94...-50	-94...-50
Propagation condition	-	AWGN	

NOTE 1: *loc* level shall be adjusted according the total signal power *Io* at receiver input and the geometry factor *lor/loc*.

- 1) UE is in idle mode and camped on cell 1. SS sends System Information Block type 11 message including intra-frequency measurement reporting criteria IE.
- 2) SS prompts the operator to make an outgoing call.
- 3) UE shall transmit a RRC CONNECTION REQUEST message on CCCH.
- 4) SS shall transmit a RRC CONNECTION SETUP message and allocates DPCH physical channels to UE.
- 5) UE shall transmit a RRC CONNECTION SETUP COMPLETE message and move to CELL_DCH state.
- 6) UE shall transmit a MEASUREMENT REPORT message.

8.7.1.1.1.4.2 Procedure

CPICH RSCP measured from Cell 1 is compared to CPICH Ec power.

8.7.1.1.1.5 Test requirements

The CPICH RSCP measurement accuracy shall meet the requirements in subclause 8.7.1.1.1.2.

NOTE: If the above Test Requirement differs from the Minimum Requirement then the Test Tolerance applied for this test is non-zero. The Test Tolerance for this test is defined in Annex F.2 and the explanation of how the Minimum Requirement has been relaxed by the Test Tolerance is given in Annex F.4.

8.7.1.1.2 8.7.1.1.2 Relative accuracy requirement

8.7.1.1.2.1 Definition and applicability

The relative accuracy of CPICH RSCP is defined as the CPICH RSCP measured from one cell compared to the CPICH RSCP measured from another cell on the same frequency.

The requirements and this test apply to all types of UTRA for the FDD UE.

8.7.1.1.2.2 Minimum Requirements

The accuracy requirements in Table 8.7.1.1.2.1 are valid under the following conditions:

- CPICH RSCP_{1,2} ≥ -114 dBm.

$$\left| CPICH_RSCP1|_{in\ dB} - CPICH_RSCP2|_{in\ dB} \right| \leq 20dB$$

$$\left| \frac{I_o}{\hat{I}_{or}} \right|_{in\ dB} - \left(\frac{CPICH_E_c}{I_{or}} \right)_{in\ dB} \leq 20dB$$

Table 8.7.1.1.2.1: CPICH RSCP Intra frequency relative accuracy

Parameter	Unit	Accuracy [dB]		Conditions
		Normal condition	Extreme condition	Io [dBm]
CPICH_RSCP	dBm	± 3	± 3	-94...-50

The normative reference for this requirement is [2] TS 25.133 subclause 9.1.1.1.2 and A.9.1.1.2.

8.7.1.1.2.3 Test purpose

The purpose of this test is to verify that the CPICH RSCP relative measurement accuracy is within the specified limits in subclause 8.7.1.1.2.2. This measurement is for handover evaluation, DL open loop power control, UL open loop control and for the calculation of pathloss.

8.7.1.1.2.4 Method of test

8.7.1.1.2.4.1 Initial conditions

Test environment: normal, TL/VL, TL/VH, TH/VL, TH/VH; see subclauses G.2.1 and G.2.2.

Frequencies to be tested: mid range; see subclause G.2.4.

In this case all cells are on the same frequency. Table 8.7.1.1.2 defines the limits of signal strengths and code powers, when the requirements are applicable. When verifying the CPICH RSCP intra frequency relative accuracy requirement both cell 1 and 2 in Table 8.7.1.1.2 shall be present.

- 1) UE is in idle mode and camped on cell 1. SS sends System Information Block type 11 message including intra-frequency measurement reporting criteria IE.
- 2) SS prompts the operator to make an outgoing call.
- 3) UE shall transmit a RRC CONNECTION REQUEST message on CCCH.
- 4) SS shall transmit a RRC CONNECTION SETUP message and allocates DPCH physical channels to UE.
- 5) UE shall transmit a RRC CONNECTION SETUP COMPLETE message and move to CELL_DCH state.
- 6) UE shall transmit a MEASUREMENT REPORT message.

8.7.1.1.2.4.2 Procedure

- 1) CPICH RSCP measured from cell 1 is compared to the CPICH RSCP measured from cell 2.
- 2) The result of step 1) is compared to actual level difference of CPICH_Ec of Cell 1 and Cell 2.

8.7.1.1.2.5 Test requirements

The CPICH RSCP measurement accuracy shall meet the requirements in subclause 8.7.1.1.2.2.

NOTE: If the above Test Requirement differs from the Minimum Requirement then the Test Tolerance applied for this test is non-zero. The Test Tolerance for this test is defined in Annex F.2 and the explanation of how the Minimum Requirement has been relaxed by the Test Tolerance is given in Annex F.4.

8.7.1.2 Inter frequency measurement accuracy

8.7.1.2.1 ~~8.7.1.2.1~~ Relative accuracy requirement

8.7.1.2.1.1 ~~8.7.1.2.1.1~~ Definition and applicability

The relative accuracy of CPICH RSCP in inter frequency case is defined as the CPICH RSCP measured from one cell compared to the CPICH RSCP measured from another cell on a different frequency.

The requirements and this test apply to all types of UTRA for the FDD UE.

8.7.1.2.1.2 ~~8.7.1.2.1.2~~ Minimum Requirements

The accuracy requirements in Table 8.7.1.2.1.1 are valid under the following conditions:

- ~~CPICH_RSCP1,2 ≥ -114 dBm.~~
- ~~$$\left| CPICH_RSCP1 \Big|_{in\ dB} - CPICH_RSCP2 \Big|_{in\ dB} \right| \leq 20dB$$~~
- ~~$| Channel\ 1\ I_o - Channel\ 2\ I_o | \leq 20\ dB.$~~
- ~~$$\left(\frac{I_o}{\hat{I}_{or}} \right) \Big|_{in\ dB} - \left(\frac{CPICH_E_c}{I_{or}} \right) \Big|_{in\ dB} \leq 20dB$$~~

Table 8.7.1.2.1.1: CPICH RSCP Inter frequency relative accuracy

Parameter	Unit	Accuracy [dB]		Conditions
		Normal condition	Extreme condition	Io [dBm]
CPICH RSCP	dBm	± 6	± 6	-94...-50

The normative reference for this requirement is [2] TS 25.133 subclause 9.1.1.2.1 and A.9.1.1.2.

8.7.1.2.1.3 ~~8.7.1.2.1.3~~ Test purpose

The purpose of this test is to verify that the CPICH RSCP relative measurement accuracy is within the specified limits in subclause 8.7.1.2.1.2. This measurement is for handover evaluation, DL open loop power control, UL open loop control and for the calculation of pathloss.

8.7.1.2.1.4 ~~8.7.1.2.1.4~~ Method of test

8.7.1.2.1.4.1 ~~8.7.1.2.1.4.1~~ Initial conditions

Test environment: normal, TL/VL, TL/VH, TH/VL, TH/VH; see subclauses G.2.1 and G.2.2.

Frequencies to be tested: mid range; see subclause G.2.4.

In this case both cells are on different frequencies and compressed mode is applied. The gap length is 7, detailed definition is in Annex C.5 [14 slots is FFS]. Table 8.7.1.2.1.2 defines the limits of signal strengths and code powers, where the requirement is applicable.

When verifying the CPICH RSCP inter frequency relative accuracy requirement both cell 1 and 2 in Table 8.7.1.2.1.2 shall be present.

Table 8.7.1.2.1.2: CPICH RSCP Inter frequency tests parameters

Parameter	Unit	Cell 1	Cell 2
UTRA RF Channel number		Channel 1	Channel 2
CPICH Ec/lor	dB	-10	-10
PCCPCH Ec/lor	dB	-12	-12
SCH Ec/lor	dB	-12	-12
PICH Ec/lor	dB	-15	-15
DPCH Ec/lor	dB	-15	-15
OCNS	dB	-1.11	-1.11
\hat{I} or/loc	dB	10.1	10.1
loc	dBm/ 3.84 MHz	$I_o - 10.6 \text{ dB} = I_{oc}$, Note 1	$I_o - 10.6 \text{ dB} = I_{oc}$, Note 1
Range 1: I_o		-94...-70	-94...-70
Range 2: I_o	dBm	-94...-50	-94...-50
Propagation condition	-	AWGN	
NOTE 1: I_{oc} level shall be adjusted in each carrier frequency according to the total signal power I_o at receiver input and the geometry factor \hat{I} or/loc.			

- 1) UE is in idle mode and camped on cell 1. SS sends System Information Block type 11 message.
- 2) SS prompts the operator to make an outgoing call.
- 3) UE shall transmit a RRC CONNECTION REQUEST message on CCCH.
- 4) SS shall transmit a RRC CONNECTION SETUP message and allocates DPCH physical channels to UE.
- 5) UE shall transmit a RRC CONNECTION SETUP COMPLETE message and move to CELL_DCH state.
- 6) SS shall transmit MEASUREMENT CONTROL message. SS requests UE to start inter frequency measurement for cell 1 and cell 2. DPCH compressed mode status info IE is set to simultaneously activate compressed mode pattern.
- 7) UE shall transmit a MEASUREMENT REPORT message.

8.7.1.2.1.4.2 Procedure

- 1) CPICH RSCP measured from cell 1 is compared to the CPICH RSCP measured from cell 2.
- 2) The result of step 1) is compared to actual level difference of CPICH Ec power of Cell 1 and Cell 2.

8.7.1.2.1.5 Test requirements

The CPICH RSCP measurement accuracy shall meet the requirements in subclause 8.7.1.2.1.2.

NOTE: If the above Test Requirement differs from the Minimum Requirement then the Test Tolerance applied for this test is non-zero. The Test Tolerance for this test is defined in Annex F.2 and the explanation of how the Minimum Requirement has been relaxed by the Test Tolerance is given in Annex F.4.

8.7.1.3 CPICH RSCP measurement report mapping

CHANGE REQUEST

⌘ **34.121** **CR 085** ⌘ rev **-** ⌘ Current version: **3.4.0** ⌘

For **HELP** on using this form, see bottom of this page or look at the pop-up text over the ⌘ symbols.

Proposed change affects: ⌘ (U)SIM ME/UE Radio Access Network Core Network

Title:	⌘ Measurement accuracy of CPICH Ec/Io		
Source:	⌘ T1/RF		
Work item code:	⌘	Date:	⌘ 2001-5-14
Category:	⌘ F	Release:	⌘ R99
	<i>Use one of the following categories:</i> F (essential correction) A (corresponds to a correction in an earlier release) B (Addition of feature), C (Functional modification of feature) D (Editorial modification) Detailed explanations of the above categories can be found in 3GPP TR 21.900.		<i>Use one of the following releases:</i> 2 (GSM Phase 2) R96 (Release 1996) R97 (Release 1997) R98 (Release 1998) R99 (Release 1999) REL-4 (Release 4) REL-5 (Release 5)

Reason for change:	⌘ Description for test case is missing in TS34.121		
Summary of change:	⌘ Test case description is proposed for intra and inter frequency measurement accuracy of CPICH Ec/Io. Also test conditions are proposed in this CR.		
Consequences if not approved:	⌘ The test description is missing in TS 34.121 for measurement accuracy of CPICH Ec/Io requirement in TS 25.133.		

Clauses affected:	⌘ 8.7.2		
Other specs Affected:	<input type="checkbox"/> Other core specifications ⌘ <input type="checkbox"/> Test specifications ⌘ <input type="checkbox"/> O&M Specifications ⌘		
Other comments:	⌘		

How to create CRs using this form:

Comprehensive information and tips about how to create CRs can be found at: http://www.3gpp.org/3G_Specs/CRs.htm. Below is a brief summary:

- 1) Fill out the above form. The symbols above marked ⌘ contain pop-up help information about the field that they are closest to.
- 2) Obtain the latest version for the release of the specification to which the change is proposed. Use the MS Word "revision marks" feature (also known as "track changes") when making the changes. All 3GPP specifications can be downloaded from the 3GPP server under <ftp://www.3gpp.org/specs/>. For the latest version, look for the directory name with the latest date e.g. 2000-09 contains the specifications resulting from the September 2000 TSG meetings.
- 3) With "track changes" disabled, paste the entire CR form (use CTRL-A to select it) into the specification just in front of the clause containing the first piece of changed text. Delete those parts of the specification which are not relevant to the change request.

8.7.2 CPICH Ec/Io

8.7.2.1 Intra frequency measurements accuracy

8.7.2.1.1 Absolute accuracy requirement

8.7.2.1.1.1 Definition and applicability

The absolute accuracy of CPICH Ec/Io is defined as the CPICH Ec/Io measured from one cell compared to the CPICH Ec/Io power from same cell.

The requirements and this test apply to all types of UTRA for the FDD UE.

8.7.2.1.1.2 Minimum Requirements

The accuracy requirements in Table 8.7.2.1.1.1 are valid under the following conditions:

- CPICH_RSCP1 ≥ -114 dBm.

$$\left| \frac{I_o}{\hat{I}_{or}} \right|_{in \text{ dB}} - \left(\frac{CPICH - E_c}{I_{or}} \right)_{in \text{ dB}} \leq 20dB$$

Table 8.7.2.1.1.1: CPICH Ec/Io Intra frequency absolute accuracy

Parameter	Unit	Accuracy [dB]		Conditions Io [dBm]
		Normal condition	Extreme condition	
CPICH Ec/Io	dB	± 1.5 for -14 ≤ CPICH Ec/Io ± 2 for -16 ≤ CPICH Ec/Io < -14 ± 3 for -20 ≤ CPICH Ec/Io < -16	± 3	-94...-50

The normative reference for this requirement is [2] TS 25.133 subclause 9.1.2.1.1 and A.9.1.2.2.

8.7.2.1.1.3 Test purpose

The purpose of this test is to verify that the CPICH Ec/Io absolute measurement accuracy is within the specified limits in subclause 8.7.2.1.1.2. This measurement is for Cell selection/re-selection and for handover evaluation.

8.7.2.1.1.4 Method of test

8.7.2.1.1.4.1 Initial conditions

Test environment: normal, TL/VL, TL/VH, TH/VL, TH/VH; see subclauses G.2.1 and G.2.2.

Frequencies to be tested: mid range; see subclause G.2.4.

Table 8.7.2.1.1.2 defines the limits of signal strengths and code powers, where the requirements are applicable.

When verifying the CPICH Ec/Io intra frequency absolute accuracy requirement only cell 1 in Table 8.7.2.1.1.2 shall be present.

Table 8.7.2.1.1.2: CPICH Ec/Io Intra frequency test parameters

Parameter	Unit	Cell 1	Cell 2
UTRA RF Channel number		Channel 1	Channel 1
<i>CPICH Ec/Io</i>	dB	-10	-10
<i>PCCPCH Ec/Io</i>	dB	-12	-12
<i>SCH Ec/Io</i>	dB	-12	-12
<i>PICH Ec/Io</i>	dB	-15	-15
<i>DPCH Ec/Io</i>	dB	-15	-15
<i>OCNS</i>	dB	-1.11	-1.11
<i>Ior/Ioc</i>	dB	10.5	10.5
<i>Ioc</i>	dBm/ 3.84 MHz	<i>Io -13.7 dB = Ioc,</i> Note 1	<i>Io -13.7 dB = Ioc,</i> Note 1
<i>Range 1: Ioc</i>	dBm	-94...-70	-94...-70
<i>Range 2: Ioc</i>	dBm	-94...-50	-94...-50
Propagation condition	-	AWGN	
NOTE 1: <i>Ioc</i> level shall be adjusted according the total signal power <i>Io</i> at receiver input and the geometry factor <i>Ior/Ioc</i> .			

- 1) UE is in idle mode and camped on cell 1. SS sends System Information Block type 11 message including intra-frequency measurement reporting criteria IE.
- 2) SS prompts the operator to make an outgoing call.
- 3) UE shall transmit a RRC CONNECTION REQUEST message on CCCH.
- 4) SS shall transmit a RRC CONNECTION SETUP message and allocates DPCH physical channels to UE.
- 5) UE shall transmit a RRC CONNECTION SETUP COMPLETE message and move to CELL_DCH state.
- 6) UE shall transmit a MEASUREMENT REPORT message.

8.7.2.1.1.4.2 Procedure

CPICH Ec/Io measured from Cell 1 is compared to CPICH Ec/Io power from same cell.

8.7.2.1.1.5 Test requirements

The CPICH Ec/Io measurement accuracy shall meet the requirements in subclause 8.7.2.1.1.2.

NOTE: If the above Test Requirement differs from the Minimum Requirement then the Test Tolerance applied for this test is non-zero. The Test Tolerance for this test is defined in Annex F.2 and the explanation of how the Minimum Requirement has been relaxed by the Test Tolerance is given in Annex F.4.

8.7.2.1.2 Relative accuracy requirement

8.7.2.1.2.1 Definition and applicability

The relative accuracy of CPICH Ec/Io is defined as the CPICH Ec/Io measured from one cell compared to the CPICH Ec/Io measured from another cell on the same frequency.

The requirements and this test apply to all types of UTRA for the FDD UE.

8.7.2.1.2.2 Minimum Requirements

The accuracy requirements in Table 8.7.2.1.2.1 are valid under the following conditions:

- CPICH_RSCP1,2 ≥ -114 dBm.

- $\left| CPICH_RSCP1 \Big|_{in\ dB} - CPICH_RSCP2 \Big|_{in\ dB} \right| \leq 20dB$

$$\left| \frac{I_o}{\hat{I}_{or}} \right|_{in \text{ dB}} - \left(\frac{CPICH_Ec}{I_{or}} \right)_{in \text{ dB}} \leq 20dB$$

Table 8.7.2.1.2.1: CPICH Ec/Io Intra frequency relative accuracy

Parameter	Unit	Accuracy [dB]		Conditions
		Normal condition	Extreme condition	Io [dBm]
CPICH_Ec/Io	dB	± 1.5 for -14 ≤ CPICH Ec/Io ± 2 for -16 ≤ CPICH Ec/Io < -14 ± 3 for -20 ≤ CPICH Ec/Io < -16	± 3	-94...-50

The normative reference for this requirement is [2] TS 25.133 subclause 9.1.2.1.2 and A.9.1.2.2.

8.7.2.1.2.3 Test purpose

The purpose of this test is to verify that the CPICH Ec/Io relative measurement accuracy is within the specified limits in subclause 8.7.2.1.2.2. This measurement is for Cell selection/re-selection and for handover evaluation.

8.7.2.1.2.4 Method of test

8.7.2.1.2.4.1 Initial conditions

Test environment: normal, TL/VL, TL/VH, TH/VL, TH/VH; see subclauses G.2.1 and G.2.2.

Frequencies to be tested: mid range; see subclause G.2.4.

In this case all cells are in the same frequency. Table 8.7.2.1.1.2 defines the limits of signal strengths and code powers, where the requirements are applicable. When verifying the CPICH Ec/Io intra frequency relative accuracy requirement both cell 1 and 2 in Table 8.7.2.1.1.2 shall be present.

- 1) UE is in idle mode and camped on cell 1. SS sends System Information Block type 11 message including intra-frequency measurement reporting criteria IE.
- 2) SS prompts the operator to make an outgoing call.
- 3) UE shall transmit a RRC CONNECTION REQUEST message on CCCH.
- 4) SS shall transmit a RRC CONNECTION SETUP message and allocates DPCH physical channels to UE.
- 5) UE shall transmit a RRC CONNECTION SETUP COMPLETE message and move to CELL_DCH state.
- 6) UE shall transmit a MEASUREMENT REPORT message.

8.7.2.1.2.4.2 Procedure

- 1) CPICH Ec/Io measured from cell 1 is compared to the CPICH Ec/Io measured from cell 2.
- 2) The result of step 1) is compared to actual level difference of CPICH_Ec power of Cell 1 and Cell 2.

8.7.2.1.2.5 Test requirements

The CPICH Ec/Io measurement accuracy shall meet the requirements in subclause 8.7.2.1.2.2.

NOTE: If the above Test Requirement differs from the Minimum Requirement then the Test Tolerance applied for this test is non-zero. The Test Tolerance for this test is defined in Annex F.2 and the explanation of how the Minimum Requirement has been relaxed by the Test Tolerance is given in Annex F.4.

8.7.2.2 Inter frequency measurement accuracy

8.7.2.2.1 Absolute accuracy requirement

8.7.2.2.1.1 Definition and applicability

[TBD]

8.7.2.2.1.2 Minimum Requirements

The accuracy requirements in Table 8.7.2.2.1.1 are valid under the following conditions:

- CPICH RSCP1 \geq -114 dBm.

$$-\frac{I_o}{(\hat{I}_{or})_{in \text{ dB}}} - \left(\frac{CPICH - E_c}{I_{or}} \right)_{in \text{ dB}} \leq 20dB$$

Table 8.7.2.2.1.1: CPICH Ec/Io Inter frequency absolute accuracy

Parameter	Unit	Accuracy [dB]		Conditions Io [dBm]
		Normal condition	Extreme condition	
CPICH Ec/Io	dB	± 1.5 for $-14 \leq$ CPICH Ec/Io ± 2 for $-16 \leq$ CPICH Ec/Io < -14 ± 3 for $-20 \leq$ CPICH Ec/Io < -16	± 3	-94...-50

The normative reference for this requirement is [2] TS 25.133 subclause 9.1.2.2.1 and A.9.1.2.2.

8.7.2.2.1.3 Test purpose

The purpose of this test is to verify that the CPICH Ec/Io absolute measurement accuracy is within the specified limits in subclause 8.7.2.2.1.2. This measurement is for Cell selection/re-selection and for handover evaluation.

8.7.2.2.1.4 Method of test

8.7.2.2.1.4.1 Initial conditions

Test environment: normal, TL/VL, TL/VH, TH/VL, TH/VH; see subclauses G.2.1 and G.2.2.

Frequencies to be tested: mid range; see subclause G.2.4.

[TBD]

8.7.2.2.1.4.2 Procedure

[TBD]

8.7.2.2.1.5 Test requirements

The CPICH Ec/Io measurement accuracy shall meet the requirements in subclause 8.7.2.2.1.2.

NOTE: If the above Test Requirement differs from the Minimum Requirement then the Test Tolerance applied for this test is non-zero. The Test Tolerance for this test is defined in Annex F.2 and the explanation of how the Minimum Requirement has been relaxed by the Test Tolerance is given in Annex F.4.

8.7.2.2.2 Relative accuracy requirement

8.7.2.2.2.1 Definition and applicability

The relative accuracy of CPICH Ec/Io in the inter frequency case is defined as the CPICH Ec/Io measured from one cell compared to the CPICH Ec/Io measured from another cell on a different frequency.

The requirements and this test apply to all types of UTRA for the FDD UE.

8.7.2.2.2.2 Minimum Requirements

The accuracy requirements in Table 8.7.2.2.2.1 are valid under the following conditions:

- CPICH RSCP1,2 ≥ -114 dBm.
- $\left| CPICH_RSCP1 \Big|_{in\ dB} - CPICH_RSCP2 \Big|_{in\ dB} \right| \leq 20dB$
- $| Channel\ 1\ I_o - Channel\ 2\ I_o | \leq 20\ dB.$
- $\left(\frac{I_o}{\hat{I}_{or}} \right) \Big|_{in\ dB} - \left(\frac{CPICH_E_c}{I_{or}} \right) \Big|_{in\ dB} \leq 20dB$

Table 8.7.2.2.2.1: CPICH Ec/Io Inter frequency relative accuracy

Parameter	Unit	Accuracy [dB]		Conditions
		Normal condition	Extreme condition	Io [dBm]
CPICH Ec/Io	dB	± 1.5 for -14 ≤ CPICH Ec/Io ± 2 for -16 ≤ CPICH Ec/Io < -14 ± 3 for -20 ≤ CPICH Ec/Io < -16	± 3	-94...-50

The normative reference for this requirement is [2] TS 25.133 subclause 9.1.2.2.2 and A.9.1.2.2.

8.7.2.2.2.3 Test purpose

The purpose of this test is to verify that the CPICH Ec/Io relative measurement accuracy is within the specified limits in subclause 8.7.2.2.2.2. This measurement is for Cell selection/re-selection and for handover evaluation.

8.7.2.2.2.4 Method of test

8.7.2.2.2.4.1 Initial conditions

Test environment: normal, TL/VL, TL/VH, TH/VL, TH/VH; see subclauses G.2.1 and G.2.2.

Frequencies to be tested: mid range; see subclause G.2.4.

In this case both cells are in different frequency and compressed mode is applied. The gap length is 7, detailed definition is in Annex C.5 [14 slots is FFS]. Table 8.7.2.2.2.2 defines the limits of signal strengths and code powers, where the requirement is applicable.

When verifying the CPICH Ec/Io inter frequency relative accuracy requirement both cell 1 and 2 in Table 8.7.2.2.2.2 shall be present.

Table 8.7.2.2.2: CPICH Ec/Io Inter frequency tests parameters

Parameter	Unit	Cell 1	Cell 2
UTRA RF Channel number		Channel 1	Channel 2
CPICH Ec/Io	dB	-10	-10
PCCPCH Ec/Io	dB	-12	-12
SCH Ec/Io	dB	-12	-12
PICH Ec/Io	dB	-15	-15
DPCH Ec/Io	dB	-15	-15
OCNS	dB	-1.11	-1.11
\hat{I}_{or}/I_{oc}	dB	10.1	10.1
I_{oc}	dBm/ 3.84 MHz	$I_{oc} - 10.6 \text{ dB} = I_{oc}$, Note 1	$I_{oc} - 10.6 \text{ dB} = I_{oc}$, Note 1
Range 1: I_{oc}	dBm	-94...-70	-94...-70
Range 2: I_{oc}		-94...-50	-94...-50
Propagation condition	-	AWGN	
NOTE 1: I_{oc} level shall be adjusted in each carrier frequency according to the total signal power I_{oc} at receiver input and the geometry factor \hat{I}_{or}/I_{oc} .			

- 1) UE is in idle mode and camped on cell 1. SS sends System Information Block type 11 message.
- 2) SS prompts the operator to make an outgoing call
- 3) UE shall transmit a RRC CONNECTION REQUEST message on CCCH.
- 4) SS shall transmit a RRC CONNECTION SETUP message and allocates DPCH physical channels to UE.
- 5) UE shall transmit a RRC CONNECTION SETUP COMPLETE message and move to CELL_DCH state.
- 6) SS shall transmit MEASUREMENT CONTROL message. SS requests UE to start inter frequency measurement for cell 1 and cell 2. DPCH compressed mode status info IE is set to simultaneously activate compressed mode pattern.
- 7) UE shall transmit a MEASUREMENT REPORT message.

8.7.2.2.2.4.2 Procedure

- 1) CPICH Ec/Io measured from cell 1 is compared to the CPICH Ec/Io measured from cell 2.
- 2) The result of step 1) is compared to actual level difference of CPICH Ec power of Cell 1 and Cell 2.

8.7.2.2.2.5 Test requirements

The CPICH Ec/Io measurement accuracy shall meet the requirements in subclause 8.7.2.2.2.

NOTE: If the above Test Requirement differs from the Minimum Requirement then the Test Tolerance applied for this test is non-zero. The Test Tolerance for this test is defined in Annex F.2 and the explanation of how the Minimum Requirement has been relaxed by the Test Tolerance is given in Annex F.4.

8.7.2.3 CPICH Ec/Io measurement report mapping

CHANGE REQUEST

⌘ **TS 34.121 CR 086** ⌘ rev ⌘ Current version: **3.4.0** ⌘

For **HELP** on using this form, see bottom of this page or look at the pop-up text over the ⌘ symbols.

Proposed change affects: ⌘ (U)SIM ME/UE Radio Access Network Core Network

Title:	⌘ Modifications to the structure of RRM test cases (FDD)				
Source:	⌘ T1/RF				
Work item code:	⌘ 	Date:	⌘ 14 May, 2001		
Category:	⌘ F	Release:	⌘ R99		
<i>Use <u>one</u> of the following categories:</i> F (essential correction) A (corresponds to a correction in an earlier release) B (Addition of feature), C (Functional modification of feature) D (Editorial modification)			<i>Use <u>one</u> of the following releases:</i> 2 (GSM Phase 2) R96 (Release 1996) R97 (Release 1997) R98 (Release 1998) R99 (Release 1999) REL-4 (Release 4) REL-5 (Release 5)		
Detailed explanations of the above categories can be found in 3GPP TR 21.900.					

Reason for change:	⌘ To keep consistency with the core specification
Summary of change:	⌘ Modify the structure of Chapter 8
Consequences if not approved:	⌘ Inconsistencies with the core specification are caused.

Clauses affected:	⌘ Chapter 8
Other specs affected:	⌘ <input type="checkbox"/> Other core specifications ⌘ <input type="checkbox"/> Test specifications <input type="checkbox"/> O&M Specifications
Other comments:	⌘

How to create CRs using this form:

Comprehensive information and tips about how to create CRs can be found at: http://www.3gpp.org/3G_Specs/CRs.htm. Below is a brief summary:

- 1) Fill out the above form. The symbols above marked ⌘ contain pop-up help information about the field that they are closest to.
- 2) Obtain the latest version for the release of the specification to which the change is proposed. Use the MS Word "revision marks" feature (also known as "track changes") when making the changes. All 3GPP specifications can be downloaded from the 3GPP server under <ftp://www.3gpp.org/specs/>. For the latest version, look for the directory name with the latest date e.g. 2000-09 contains the specifications resulting from the September 2000 TSG meetings.
- 3) With "track changes" disabled, paste the entire CR form (use CTRL-A to select it) into the specification just in front of the clause containing the first piece of changed text. Delete those parts of the specification which are not relevant to the change request.

8 Requirements for support of RRM

8.1 General

8.2 Idle Mode Tasks

8.2.1 Cell Selection

~~8.2.1.1 Cell Selection; the cells in the neighbour list belong to different frequencies~~

~~8.2.1.1.1 Definition and applicability~~

~~Test to verify that the UE is capable of selecting a suitable cell and camp on it within [X] seconds from switch on with stored information of the last registered PLMN. The stored information cell selection delay is then defined as the time the UE needs for sending the preamble for RRC Connection Request for Location Registration to UTRAN after the power has been switched on with a valid USIM and PIN is disabled. The test environment contains multiple cells.~~

~~This test is applicable for all UEs.~~

~~8.2.1.1.2 Conformance requirement~~

~~The stored information cell selection delay shall be equal or less than [X] seconds when the cells in the neighbour list belong to less than [3] frequencies. This shall be verified in more than [X%] of the cases with a confidence level of [Y%] [FFS].~~

~~The reference for this requirement is [2] TS 25.133 subclause 4.1.2.1.1 and A.4.1.1.2.~~

~~8.2.1.1.3 Test purpose~~

~~To verify that the UE meets the conformance requirement.~~

~~8.2.1.1.4 Method of test~~

~~8.2.1.1.4.1 Initial conditions~~

~~This scenario implies the presence of 2 carriers and 6 cells (3 cells per carrier) as given in Table 8.2.1 and 8.2.2.~~

~~The stored information of the last registered PLMN is used in this test. The stored information includes one of the UTRA RF CHANNEL NUMBERS used in the test. All the cells in the test are given in the measurement control information of each cell, which are on the RF carrier stored in the UE.~~

Table 8.2.1: General test parameters for Cell Selection in Multi carrier case

	Parameter	Unit	Value	Comment
Initial condition	Stored RF channel		Channel1	
	Neighbour cells of Cell1		Cell2, Cell3, Cell4, Cell5, Cell6	
	Neighbour cells of Cell2		Cell1, Cell3, Cell4, Cell5, Cell6	
	Neighbour cells of Cell3		Cell1, Cell2, Cell4, Cell5, Cell6	
Final condition	Active cell		Cell5	

~~The relative RF signal to total interference ratio at the UE ($CPICH_Ec/I_0$) between the cells is shown in Table 8.2.2 and shall be:~~

~~Cell 5 > Cell 1 > Cell 2 > Cell 4 > Cell 3 > Cell 6~~

The absolute signal level of each cell can be obtained from the values of \hat{I}_{or}/I_{oc} in table 8.2.2.

Table 8.2.2: Test parameters for Cell selection multi-carrier multi-cell

Parameter	Unit	Cell-1	Cell-2	Cell-3	Cell-4	Cell-5	Cell-6
UTRA RF Channel Number		Channel 1	Channel 1	Channel 1	Channel 2	Channel 2	Channel 2
CPICH_Ec/I _{or}	dB	-10	-10	-10	-10	-10	-10
P-CCPCH_Ec/I _{or}	dB	-12	-12	-12	-12	-12	-12
SCH_Ec/I _{or}	dB	-12	-12	-12	-12	-12	-12
PICH_Ec/I _{or}	dB	-15	-15	-15	-15	-15	-15
OCNS_Ec/I _{or}	dB	-0.941	-0.941	-0.941	-0.941	-0.941	-0.941
\hat{I}_{or}/I_{oc}	dB	5.3	2.3	-1.7	6.3	14.3	2.3
I_{oc}	dBm/ 3.84 MHz	-70			-70		
CPICH_Ec/I _e	dB	-13	-16	-20	-19	-11	-23
Propagation Condition		AWGN			AWGN		
Q _{qualmin}	dB	[]	[]	[]	[]	[]	[]
Q _{rxlevmin}	dBm	[]	[]	[]	[]	[]	[]
UE_TXPWR_MAX_RACH	dBm	[]	[]	[]	[]	[]	[]
Q _{offset_{s,n}}	dB	C1, C2: [] C1, C3: [] C1, C4: [] C1, C5: [] C1, C6: []	C2, C1: [] C2, C3: [] C2, C4: [] C2, C5: [] C2, C6: []	C3, C1: [] C3, C2: [] C3, C4: [] C3, C5: [] C3, C6: []	C4, C1: [] C4, C2: [] C4, C3: [] C4, C5: [] C4, C6: []	C5, C1: [] C5, C2: [] C5, C3: [] C5, C4: [] C5, C6: []	C6, C1: [] C6, C2: [] C6, C3: [] C6, C4: [] C6, C5: []

8.2.1.1.4.2 Procedures

- a) The SS activates cell 1-6 and monitors cell 5, 1 and 2 for random access requests from the UE
- b) The UE is switched on.
- c) The SS waits for random access request from the UE
- d) The UE is switched off.
- e) The SS monitors cell 5, 1 and 2 for random access requests from the UE
- f) The UE is switched on
- g) The SS waits for random access request from the UE
- h) Repeat step d) to g) [TBD] times

8.2.1.1.5 Test requirements

- 1) In step c), the UE shall respond on cell 5 within [FFS seconds]
[Editor's note: LS of proposed timeout values sent to CN1/RAN2 to get acceptance]
- 2) In step g), the UE shall respond on cell 5 within [X] seconds in more than [X%] of the cases.
[Editor's note: The test must be executed a number of times as indirectly set by the Conformance Requirement The number is for FFS]

8.2.1.2 Cell Selection; no cell is present in the neighbour list

8.2.1.2.1 Definition and applicability

Test to verify that the UE is capable of selecting a suitable cell and camp on it within [5] seconds from switch on with stored information of the last registered PLMN. The stored information cell selection delay is then defined as the time the UE needs for sending the preamble for RRC Connection Request for Location Registration to UTRAN after the power has been switched on with a valid USIM and PIN is disabled. The test environment contains only one cell.

This test is applicable for all UEs.

8.2.1.2.2 Conformance requirement

The stored information cell selection delay shall be equal or less than [5] seconds. This shall be verified in more than [X%] of the cases with a confidence level of [Y%] [FFS].

The reference for this requirement is [2] TS 25.133 subclause 4.1.2.1.2 and A.4.1.2.2.

8.2.1.2.3 Test purpose

To verify that the UE meets the conformance requirement.

8.2.1.2.4 Method of test

8.2.1.2.4.1 Initial conditions

This scenario implies the presence of 1 carrier and 1 cell.

The stored information of the last registered PLMN is used in this test. The stored information includes the UTRA RF CHANNEL NUMBER. The active cell in the test does not contain any neighbour cells in its measurement control information.

The absolute signal level of the cell can be obtained from the value of \hat{I}_{or}/I_{oc} in table 8.2.3.

Table 8.2.3: Test parameters for Cell selection single carrier single cell

Parameter	Unit	Cell 1
UTRA RF Channel Number		Channel 1
CPICH_Ec/I _{or}	dB	-10
P-CCPCH_Ec/I _{or}	dB	-12
SCH_Ec/I _{or}	dB	-12
PICH_Ec/I _{or}	dB	-15
OCNS_Ec/I _{or}	dB	-0.941
\hat{I}_{or}/I_{oc}	dB	0
I_{oc}	dBm/3-84 MHz	-70
GPICH_Ec/I _o	dB	-13
Propagation Condition		AWGN
Q _{qualmin}	dB	[]
Q _{rxlevmin}	dBm	[]
UE_TXPWR_MAX_RACH	dBm	[]

8.2.1.2.4.2 Procedures

- The SS activates cell 1 and monitors cell 1 for random access request from the UE

- ~~b) The UE is switched on~~
- ~~c) The SS waits for random access request from the UE~~
- ~~d) The UE is switched off~~
- ~~e) The SS monitors cell 1 for random access request from the UE~~
- ~~f) The UE is switched on~~
- ~~g) The SS waits for random access request from the UE~~
- ~~h) Repeat step d) to g) [TBD] times~~

~~8.2.1.2.5 Test requirements~~

- ~~1) In step c), the UE shall respond on cell 1 within [FFS seconds]
[Editor's note: LS of proposed timeout values sent to CN1/RAN2 to get acceptance]~~
- ~~2) In step g), the UE shall respond on cell 1 within [5] seconds in more than [X%] of the cases.
[Editor's note: The test must be executed a number of times as indirectly set by the Conformance Requirement. The number is for FFS]~~

8.2.2 Cell Re-Selection

~~8.2.2.1 Cell Re-Selection; single carrier case~~

~~8.2.2.1.1 Definition and applicability~~

~~Test to verify that the UE is capable of re-selecting a new cell within [5] seconds from it becoming a cell to be reselected according to the cell re-selection criteria. The cell re-selection delay is then defined as the time between the occurrence of any event which will trigger Cell Reselection Evaluation process and the moment in time when the UE starts sending the preamble for RRC Connection request for Location Update message to the UTRAN.~~

~~This test is applicable for all UEs.~~

~~8.2.2.1.2 Conformance requirement~~

~~The cell re-selection delay shall be equal or less than [5] seconds. This shall be verified in more than [X%] of the cases with a confidence level of [Y%] [FFS].~~

~~The reference for this requirement is [2] TS 25.133 subclause 4.2.2.2.1 and A.4.2.1.2.~~

~~8.2.2.1.3 Test purpose~~

~~To verify that the UE meets the conformance requirement.~~

~~8.2.2.1.4 Method of test~~

~~8.2.2.1.4.1 Initial conditions~~

~~This scenario implies the presence of 1 carrier and 6 cells as given in Table 8.2.4 and 8.2.5.~~

Table 8.2.4: General test parameters for Cell Re-selection single carrier multi-cell case

Parameter		Unit	Value	Comment
Initial condition	Active cell		Cell2	
	Neighbour cells		Cell1, Cell3, Cell4, Cell5, Cell6	
Final condition	Active cell		Cell4	
T1		s		T1 need to be defined so that cell re-selection reaction time is taken into account.
T2		s		T2 need to be defined so that cell re-selection reaction time is taken into account.

The relative RF signal to total interference ratio at the UE ($CPICH_{Ec}/I_o$) between the cells is shown in Table 8.2.5 and shall be:

T1: Cell 2 > Cell 1 > Cell 3 = Cell 4 = Cell 5 = Cell 6

T2: Cell 1 > Cell 2 > Cell 3 = Cell 4 = Cell 5 = Cell 6

The absolute signal level of each cell can be obtained from the values of \hat{I}_{or}/I_{oc} in table 8.2.5.

Table 8.2.5: Test parameters for Cell re-selection single carrier multi cell

Parameter	Unit	Cell 1		Cell 2		Cell 3		Cell 4		Cell 5		Cell 6	
		T1	T2	T1	T2	T1	T2	T1	T2	T1	T2	T1	T2
UTRA_RF_Channel_Number		Channel 1		Channel 1		Channel 1		Channel 1		Channel 1		Channel 1	
CPICH_Ec/Ior	dB	-10		-10		-10		-10		-10		-10	
PCPCH_Ec/Ior	dB	-12		-12		-12		-12		-12		-12	
SCH_Ec/Ior	dB	-12		-12		-12		-12		-12		-12	
PICH_Ec/Ior	dB	-15		-15		-15		-15		-15		-15	
OCNS_Ec/Ior	dB	-0.941		-0.941		-0.941		-0.941		-0.941		-0.941	
\hat{I}_{or}/I_{oc}	dB	7.3	10.27	10.27	7.3	0.27		0.27		0.27		0.27	
I_{oc}	dBm/ 3.84 MHz	-70											
CPICH_Ec/Io	dB	-16	-13	-13	-16	-23		-23		-23		-23	
Propagation Condition		-AWGN											
Cell_selection_and_reselection_quality_measure		CPICH_Ec/N0		CPICH_Ec/N0		CPICH_Ec/N0		CPICH_Ec/N0		CPICH_Ec/N0		CPICH_Ec/N0	
Qqualmin	dB	{}		{}		{}		{}		{}		{}	
Qrxlevmin	dBm	{}		{}		{}		{}		{}		{}	
UE_TXPWR_MAX_RACH	dB	{}		{}		{}		{}		{}		{}	
Qoffset2 _{s,n}	dB	C1, C2: {} C1, C3: {} C1, C4: {} C1, C5: {} C1, C6: {}	C2, C1: {} C2, C3: {} C2, C4: {} C2, C5: {} C2, C6: {}	C3, C1: {} C3, C2: {} C3, C4: {} C3, C5: {} C3, C6: {}	C4, C1: {} C4, C2: {} C4, C3: {} C4, C5: {} C4, C6: {}	C5, C1: {} C5, C2: {} C5, C3: {} C5, C4: {} C5, C6: {}	C6, C1: {} C6, C2: {} C6, C3: {} C6, C4: {} C6, C5: {}						
Qhyst2	dB	{}		{}		{}		{}		{}		{}	
PENALTY_TIME	s	{}		{}		{}		{}		{}		{}	
TEMP_OFFSET2	dB	{}		{}		{}		{}		{}		{}	
Tresselection	s	{}		{}		{}		{}		{}		{}	
Sintrasearch	dB	{}		{}		{}		{}		{}		{}	

8.2.2.1.4.2 Procedures

- a) The SS activates cell 1-6 with T1 defined parameters and monitors cell 1 and 2 for random access requests from the UE
- b) The UE is switched on
- c) The SS waits for random access requests from the UE
- d) After [T1] seconds from switch on, the parameters are changed as described for T2
- e) The SS waits for random access requests from the UE
- f) After [T2] seconds from switch on, the parameters are changed as described for T1
- g) Repeat step c) to f) [TBD] times

8.2.2.1.5 ~~Test requirements~~

1) ~~In step e), the UE shall respond on cell 2 within [FFS seconds]~~

~~[Editor's note: LS of proposed timeout values sent to CN1/RAN2 to get acceptance]~~

2) ~~In step e), the UE shall respond on cell 1 within [5] seconds in more than [X%] of the cases.~~

~~[Editor's note: The test must be executed a number of times as indirectly set by the Conformance Requirement The number is for FFS]~~

8.2.2.2 ~~Cell Re-Selection; multi carrier case~~

8.2.2.2.1 ~~Definition and applicability~~

~~Test to verify that the UE is capable of re-selecting a new cell within [Nt] seconds from it becoming a cell to be reselected according to the cell re-selection criteria. The cell re-selection delay is then defined as the time between the occurrence of any event which will trigger Cell Reselection Evaluation process and the moment in time when the UE starts sending the preamble for RRC Connection request for Location Update message to the UTRAN.~~

~~This test is applicable for all UEs.~~

8.2.2.2.2 ~~Conformance requirement~~

~~The cell re-selection delay shall be equal or less than [Nt] seconds. This shall be verified in more than [90%] of the cases with a confidence level of [Y%] [FFS]~~

~~The reference for this requirement is [2] TS 25.133 subclause 4.2.2.2.2 and A.4.2.2.2.~~

8.2.2.2.3 ~~Test purpose~~

~~To verify that the UE meets the conformance requirement.~~

8.2.2.2.4 ~~Method of test~~

8.2.2.2.4.1 ~~Initial conditions~~

~~This scenario implies the presence of 2 carriers and 6 cells as given in Table 8.2.6 and 8.2.7.~~

Table 8.2.6: General test parameters for Cell Re-selection in Multi-carrier case

	Parameter	Unit	Value	Comment
Initial condition	Active cell		Cell2	
	Neighbour cells		Cell1, Cell3, Cell4, Cell5, Cell6	
Final condition	Active cell		Cell4	
	T1	s		T1 need to be defined so that cell re-selection reaction time is taken into account.
	T2	s		T2 need to be defined so that cell re-selection reaction time is taken into account.

~~The relative RF signal to total interference ratio at the UE ($CPICH_{Ec}/I_o$) between the cells is shown in Table 8.2.7 and shall be:~~

~~T1: Cell 2 > Cell 1 > Cell 3 = Cell 4 = Cell 5 = Cell 6~~

~~T2: Cell 1 > Cell 2 > Cell 3 = Cell 4 = Cell 5 = Cell 6~~

~~The absolute signal level of each cell can be obtained from the values of \hat{I}_{or}/I_{oc} in table 8.2.7.~~

Table 8.2.7: Test parameters for Cell re-selection multi-carrier multi-cell

Parameter	Unit	Cell 1		Cell 2		Cell 3		Cell 4		Cell 5		Cell 6	
		T1	T2	T1	T2	T1	T2	T1	T2	T1	T2	T1	T2
UTRA-RE Channel Number		Channel 1		Channel 2		Channel 1		Channel 1		Channel 2		Channel 2	
CPICH_Ec/Ior	dB	-10		-10		-10		-10		-10		-10	
P-CCPCH_Ec/Ior	dB	-12		-12		-12		-12		-12		-12	
SCH_Ec/Ior	dB	-12		-12		-12		-12		-12		-12	
PICH_Ec/Ior	dB	-15		-15		-15		-15		-15		-15	
OCNS_Ec/Ior	dB	-0.941		-0.941		-0.941		-0.941		-0.941		-0.941	
\hat{I}_{or}/I_{oc}	dB	-3.4	2.2	2.2	-3.4	-7.4	-4.8	-7.4	-4.8	-4.8	-7.4	-4.8	-7.4
I_{oc}	dBm/ 3.84 MHz	-70											
CPICH_Ec/Io	dB	-16	-13	-13	-16	-20		-20		-20		-20	
Propagation Condition		AWGN											
Cell_selection_and_reselection_quality_measure		CPICH_Ec/N0		CPICH_Ec/N0		CPICH_Ec/N0		CPICH_Ec/N0		CPICH_Ec/N0		CPICH_Ec/N0	
Qqualmin	dB	[]		[]		[]		[]		[]		[]	
Qrxlevmin	dBm	[]		[]		[]		[]		[]		[]	
UE_TXPWR_MAX_RACH	dB	[]		[]		[]		[]		[]		[]	
Qoffset _{s,n}	dB	C1, C2: [] C1, C3: [] C1, C4: [] C1, C5: [] C1, C6: []	C2, C1: [] C2, C3: [] C2, C4: [] C2, C5: [] C2, C6: []	C3, C1: [] C3, C2: [] C3, C4: [] C3, C5: [] C3, C6: []	C4, C1: [] C4, C2: [] C4, C3: [] C4, C5: [] C4, C6: []	C5, C1: [] C5, C2: [] C5, C3: [] C5, C4: [] C5, C6: []	C6, C1: [] C6, C2: [] C6, C3: [] C6, C4: [] C6, C5: []						
Qhyst	dB	[2]		[2]		[2]		[2]		[2]		[2]	
PENALTY_TIME	s	[]		[]		[]		[]		[]		[]	
TEMP_OFFSET	dB	[]		[]		[]		[]		[]		[]	
Treselction	s	[5]		[5]		[5]		[5]		[5]		[5]	
Sintrasearch	dB	[]		[]		[]		[]		[]		[]	
Sintersearch	dB	[-8]		[-8]		[-8]		[-8]		[-8]		[-8]	

8.2.2.2.4.2 Procedures

- a) The SS activates cell 1-6 with T1 defined parameters and monitors cell 1 and 2 for random access requests from the UE
- b) The UE is switched on
- c) The SS waits for random access requests from the UE
- d) After [T1] seconds from switch on, the parameters are changed as described for T2
- e) The SS waits for random access request from the UE
- f) After [T2] seconds from switch on, the parameters are changed as described for T1
- g) Repeat step c) to f) [TBD] times

8.2.2.2.5 Test requirements

- 1) In step c), the UE shall respond on cell 2 within [FFS seconds]
[Editor's note: LS of proposed timeout values sent to CN1/RAN2 to get acceptance]
- 2) In step e), the UE shall respond on cell 1 within [Nt] seconds in more than [90%] of the cases.

~~[Editor's note: The test must be executed a number of times as indirectly set by the Conformance Requirement The number is for FFS]~~

~~8.2.2.1 Measurement and evaluation of cell selection criteria S of serving cell~~

~~8.2.2.2 Measurements of intra-frequency cells~~

~~8.2.2.3 Measurements of inter-frequency FDD cells~~

~~8.2.2.4 Measurements of inter-frequency TDD cells~~

~~8.2.2.5 Measurements of inter-RAT GSM cells~~

~~8.2.2.6 Evaluation of cell re-selection criteria~~

~~8.2.2.7 Maximum interruption in paging reception~~

~~8.2.2.8 Number of cells in cell lists~~

~~8.2.3 UTRAN to GSM Cell Re-Selection~~

~~8.2.3.1 Definition and applicability~~

~~Test to verify that a UE camped on a UTRAN cell is capable of re-selecting a GSM cell within [X] seconds from it becoming a cell to be reselected according to the cell re-selection criteria. The cell re-selection delay is then defined as the time between the occurrence of any event which will trigger Cell Reselection Evaluation process and the moment in time when the UE starts sending the RR Channel Request message for location update to GSM.~~

~~This test is applicable for UEs supporting both UTRAN and GSM.~~

~~8.2.3.2 Conformance requirement~~

~~The UTRAN to GSM cell re-selection delay shall be equal or less than [x] seconds. This shall be verified in more than [90%] of the cases with a confidence level of [Y%] [FFS]~~

~~The reference for this requirement is [2] TS 25.133 subclause 4.3.2.1 and A.4.3.1.2.~~

~~8.2.3.3 Test purpose~~

~~To verify that the UE meets the conformance requirement.~~

8.2.3.4 Method of test

8.2.3.4.1 Initial conditions

This scenario implies the presence of 1 UTRAN serving cell, and 1 GSM cell to be re-selected.

Table 8.2.8: General test parameters for UTRAN to GSM Cell Re-selection

Parameter		Unit	Value	Comment
Initial condition	Active-cell		Cell1	
	Neighbour-cell		Cell2	
Final condition	Active-cell		Cell2	
T1		s		T1 need to be defined so that cell re-selection reaction time is taken into account.
T2		s		T2 need to be defined so that cell re-selection reaction time is taken into account.

Table 8.2.9: Cell re-selection UTRAN to GSM cell case (cell 1)

Parameter	Unit	Cell 1 (UTRA)	
		T1	T2
UTRA RF Channel Number		Channel 1	
CPICH_Ec/I _{or}	dB	-10	
P-CCPCH_Ec/I _{or}	dB	-12	
SCH_Ec/I _{or}	dB	-12	
PICH_Ec/I _{or}	dB	-15	
OCNS_Ec/I _{or}	dB	-0.944	
\hat{I}_{or}/I_{oc}	dB	10.3	7.3
I_{oc}	dBm/3.84 MHz	-70	
CPICH_Ec/I _o	dB	-13	-16
CPICH_RSCP	dBm	[L1]	[L2]
Propagation Condition		AWGN	
Cell_selection_and_reselection_quality_measure		CPICH_Ec/N ₀	
Qqualmin	dB	[]	
Qrxlevmin	dBm	[]	
UE_TXPWR_MAX_RACH	dBm	[]	
Qoffset _{1s,n}	dB	C1, C2: []	
Qhyst1	dB	[]	
PENALTY_TIME	s	C2: []	
TEMP_OFFSET1	dB	C2: []	
Treselection	s	[]	
Ssearch _{RAT}	dB	[]	

Table 8.2.10: Cell re-selection UTRAN to GSM cell case (cell 2)

Parameter	Unit	Cell 2 (GSM)	
		T1	T2
Absolute RF Channel Number		ARFCN-1	
RXLEV	dBm	-70	-60
RXLEV_ACCESS_MIN	dBm	{}	
MS_TXPWR_MAX_CCH	dBm	{}	

8.2.3.4.2 Procedures

- a) The SS activates cell 1 and 2 with T1 defined parameters and monitors cell 1 and 2 for random access requests from the UE
- b) The UE is switched on
- c) The SS waits for random access request from the UE
- d) After [T1] seconds from switch on, the parameters are changed as described for T2
- e) The SS waits for random access request from the UE
- f) After [T2] seconds from switch on, the parameters are changed as described for T1
- g) Repeat step c) to f) [TBD] times

8.2.3.5 Test requirements

- 1) In step c), the UE shall respond on cell 1 within [TBD] seconds
 [Editor's note: LS of proposed timeout values sent to CN1/RAN2 to get acceptance]
- 2) In step e), the UE shall respond on cell 2 within [X] seconds in more than [90%] of the cases.
 [Editor's note: The test must be executed a number of times as indirectly set by the Conformance Requirement. The number is for FFS]

8.3 UTRAN Connected mode mobility

8.3.1 FDD/FDD Soft Handover

8.3.1.1 Active set dimension

8.3.1.2 Active set update delay

8.3.1.3 Interruption Time

8.3.2 FDD/FDD Hard Handover

8.3.2.1 Hard handover delay

8.3.2.2 Interruption time

8.3.3 FDD/TDD Handover

8.3.3.1 Hard handover delay

8.3.3.2 Interruption time

8.3.4 FDD/GSM Handover

8.3.4.1 ~~Inter-system h~~Handover delay

8.3.4.2 Interruption time

8.3.5 Cell Re-selection in CELL_FACH

8.3.5.1 ~~All cells in the neighbour list belong to the same frequency~~Intra frequency cell reselection

8.3.5.2 ~~The cells in the neighbour list belong to different frequencies~~Inter frequency cell reselection

8.3.5.3 FDD-TDD cell reselection

8.3.5.4 UTRAN-GSM Cell Reselection

8.3.6 Cell Re-selection in CELL_PCH

~~8.3.6.1 All cells in the neighbour list belong to the same frequency~~

~~8.3.6.2 — The cells in the neighbour list belong to different frequencies~~

8.3.7 Cell Re-selection in URA_PCH

~~8.3.7.1 — All cells in the neighbour list belong to the same frequency~~

~~8.3.7.2 — The cells in the neighbour list belong to different frequencies~~

8.4 RRC Connection Control

8.4.1 RRC Re-establishment

~~8.4.1.1 — Target cell known by UE~~

~~8.4.1.2 — Target cell not known by UE~~

8.4.2 Spare(void)

8.4.3 Random Access

8.4.3.1 Correct behaviour when receiving an ACK

8.4.3.2 Correct behaviour when receiving an NACK

8.4.3.3 Correct behaviour at Time-out

8.4.3.4 Correct behaviour when reaching maximum transmit power

8.4.4 Transport format combination selection in UE

8.5 Timing and Signalling characteristics

8.5.1 UE Transmit Timing

~~8.5.1.1 Initial transmission timing, Maximum timing adjustment size and Maximum timing adjustment rate~~

~~8.5.1.1.1 Definition and applicability~~

~~The UE shall have capability to follow the frame timing change of the connected Node B. UE initial transmit timing accuracy, maximum amount of timing change in one adjustment, and maximum adjustment rate are defined in the following requirements.~~

~~<Editor's Note: The applicability for this test whether it is mandatory or not should be clarified.>~~

~~8.5.1.1.2 Conformance requirements~~

~~For parameters specified in Table 8.5.1.1.1, UE initial transmission timing error shall be less than or equal to $\pm 1,5$ Chip. The reference point for the UE initial transmit timing control requirement shall be the first significant path of the corresponding downlink DPCH/DPDCH frame.~~

~~The UE shall be capable of changing the transmission timing according the received downlink DPCH/DPDCH frame. The maximum amount of the timing change in one adjustment shall be 1/4 Chip.~~

~~The maximum adjustment rate shall be 1/4 chip per 280 ms. In particular, within any given 280 ms period, the UE transmit timing shall not change in excess of $\pm 1/4$ chip from the timing at the beginning of this 280 ms period.~~

Table 8.5.1.1.1: Test parameters for Transmission timing requirement

Parameter	Cell 1 and 2 level	Unit
DPCH_Ec/I _{or}	-17	dB
I _{or} , Cell 1	-96	dBm / 3.84 MHz
I _{or} , Cell 2	-97	dBm / 3.84 MHz
Information data rate	12.2	kbps
TFCI	On	-
Propagation condition	AWGN	

~~a) Cell 2 starts transmission 5 seconds after call has been initiated. UE shall maintain it's original timing properties.~~

~~b) Cell 1 stop transmission 5 seconds after cell 2 has started transmission. UE shall adjust transmission timing with a maximum change of 1/4 chip per adjustment, and maximum timing adjustment rate of 1/4 chip per 280 ms.~~

~~The reference for this requirement is [2] TS 25.133 subclause 7.1.2 and A.7.1.2.~~

~~8.5.1.1.3 Test purpose~~

~~{TBD}~~

~~8.5.1.1.4 Method of test~~

~~8.5.1.1.4.1 Initial conditions~~

~~{TBD}~~

~~8.5.1.1.4.2 Procedures~~

~~{TBD}~~

~~8.5.1.1.5 Test requirements~~

~~{FDD}~~

~~8.5.2 Signalling Response Delay~~

~~8.5.3 Signalling Processing~~

8.6 UE Measurements Procedures

8.6.1 General Measurements Requirements in CELL_DCH State

8.6.1.1 UE Measurement Capability

8.6.1.2 FDD intra frequency measurements

8.6.1.42.1 Identification of a new cell

8.6.1.42.2 UE CPICH measurement capability

8.6.1.42.3 Periodic Reporting

8.6.1.42.4 Event Triggered Periodic Reporting

8.6.1.42.5 Event Triggered Reporting

8.6.1.23 FDD inter frequency measurements

8.6.1.23.1 Identification of a new cell

8.6.1.23.2 Measurement period

8.6.1.23.3 Periodic Reporting

8.6.1.~~23~~.4 Event Triggered Reporting

8.6.1.~~34~~ TDD measurements

8.6.1.4.1 Identification of a new cell

8.6.1.4.2 Measurement period

8.6.1.~~3-4~~.3 Periodic Reporting

8.6.1.~~3-24~~.4 Event Triggered Reporting

8.6.1.~~45~~ GSM measurements

8.6.1.~~45~~.1 GSM carrier RSSI

8.6.1.~~45~~.2 BSIC verification

8.6.1.~~45~~.2.1 Initial BSIC ~~verification~~identification

8.6.1.~~45~~.2.2 BSIC re-confirmation

8.6.2 ~~Parallel~~ Measurements in CELL_DCH State with special requirements

8.6.3 Capabilities for Support of Event Triggering and Reporting Criteria

8.6.~~34~~ Measurements in CELL_FACH State

8.6.4.1 UE Measurement Capability

8.6.4.2 FDD intra frequency measurements

8.6.4.2.1 Identification of a new cell

8.6.4.2.2 UE CPICH measurement capability

8.6.4.2.3 Periodic Reporting

8.6.4.2.4 Event Triggered Reporting

8.6.4.3 FDD inter frequency measurements

8.6.4.3.1 Identification of a new cell

8.6.4.3.2 Measurement period

8.6.4.3.3 Periodic Reporting

8.6.4.3.4 Event Triggered Reporting

8.6.4.4 TDD measurements

8.6.4.4.1 Identification of a new cell

8.6.4.4.2 Measurement period

8.6.4.5 GSM measurements

8.6.4.5.1 GSM carrier RSSI

8.6.4.5.2 BSIC verification

8.7 Measurements Performance Requirements

8.7.1 CPICH RSCP

8.7.1.1 Intra frequency measurements accuracy

8.7.1.1.1 Absolute accuracy requirement

8.7.1.1.2 Relative accuracy requirement

8.7.1.2 Inter frequency measurement accuracy

8.7.1.2.1 Relative accuracy requirement

8.7.1.3 CPICH RSCP measurement report mapping

8.7.2 CPICH Ec/Io

8.7.2.1 Intra frequency measurements accuracy

8.7.2.1.1 Absolute accuracy requirement

8.7.2.1.2 Relative accuracy requirement

8.7.2.2 Inter frequency measurement accuracy

8.7.2.2.1 Absolute accuracy requirement

8.7.2.2.2 Relative accuracy requirement

8.7.2.3 CPICH Ec/Io measurement report mapping

8.7.3 UTRA Carrier RSSI

8.7.3.1 Absolute accuracy requirement

- 8.7.3.2 Relative accuracy requirement
- 8.7.3.3 UTRA Carrier RSSI measurement report mapping
- 8.7.4 GSM carrier RSSI
- 8.7.5 Transport channel BLER
 - 8.7.5.1 BLER measurement requirement
 - 8.7.5.2 Transport channel BLER measurement report mapping
- 8.7.6 UE transmitted power
 - 8.7.6.1 Accuracy requirement
 - 8.7.6.2 UE transmitted power measurement report mapping
- 8.7.7 SFN-CFN observed time difference
 - 8.7.7.1 Intra frequency measurement requirement
 - 8.7.7.2 Inter frequency measurement requirement
 - 8.7.7.3 SFN-CFN observed time difference measurement report mapping
- 8.7.8 SFN-SFN observed time difference
 - 8.7.8.1 SFN-SFN observed time difference type 1
 - 8.7.8.1.1 Measurement requirement

8.7.8.1.2 SFN-SFN observed time difference type 1 measurement report mapping

8.7.8.2 SFN-SFN observed time difference type 2

8.7.8.2.1 Intra frequency measurement requirement accuracy without IPDL period active

8.7.8.2.2 Intra frequency measurement requirement accuracy with IPDL period active

8.7.8.2.3 Inter frequency measurement requirement accuracy

8.7.8.2.4 SFN-SFN observed time difference type 2 measurement report mapping

8.7.9 UE Rx-Tx time difference

8.7.9.1 ~~Measurement requirement~~ UE Rx-Tx time difference type 1

8.7.9.1.1 ~~Measurement requirement~~

8.7.9.1.2 ~~UE Rx-Tx time difference~~ type 1 measurement report mapping

8.7.9.2 UE Rx-Tx time difference type 2 ~~measurement report mapping~~

8.7.9.2.1 ~~Measurement requirement~~

8.7.9.2.2 ~~UE Rx-Tx time difference~~ type 2 measurement report mapping

8.7.10 Observed time difference to GSM cell

8.7.10.1 Measurement requirement

8.7.10.2 Observed time difference to GSM cell measurement report mapping

8.7.11 P-CCPCH RSCP

8.7.11.1 Absolute accuracy requirements

8.7.11.2 P-CCPCH RSCP measurement report mapping

8.7.12 UE GPS Timing of Cell Frames for LCS

8.7.12.1 UE GPS timing of Cell Frames for LCS measurement report mapping

CR-Form-v3

CHANGE REQUEST

⌘ **34.121** **CR 087** ⌘ rev **-** ⌘ Current version: **3.4.0** ⌘

For **HELP** on using this form, see bottom of this page or look at the pop-up text over the ⌘ symbols.

Proposed change affects: ⌘ (U)SIM ME/UE Radio Access Network Core Network

Title:	⌘ Propagation condition 250 km/h		
Source:	⌘ T1/RF		
Work item code:	⌘	Date:	⌘ 2001-5-14
Category:	⌘ F	Release:	⌘ R99
<p>Use <u>one</u> of the following categories:</p> <p>F (essential correction) A (corresponds to a correction in an earlier release) B (Addition of feature), C (Functional modification of feature) D (Editorial modification)</p> <p>Detailed explanations of the above categories can be found in 3GPP TR 21.900.</p>		<p>Use <u>one</u> of the following releases:</p> <p>2 (GSM Phase 2) R96 (Release 1996) R97 (Release 1997) R98 (Release 1998) R99 (Release 1999) REL-4 (Release 4) REL-5 (Release 5)</p>	

Reason for change:	⌘ Performance requirement for demodulation of DCH in multipath fading condition at 250 km/h has been added to TS 25.101 (25.101CR93).
Summary of change:	⌘ Test parameters and requirements were added for demolation of DCH in multipath fading conditions at 250 km/h (case 6). Parameters for propagation condition case 6 are added.
Consequences if not approved:	⌘ Inconsistency between core specification TS 25.101 and test specification TS34.121.

Clauses affected:	⌘ 7.3, D.2		
Other specs Affected:	⌘ <input type="checkbox"/> Other core specifications	⌘	
	<input type="checkbox"/> Test specifications		
	<input type="checkbox"/> O&M Specifications		
Other comments:	⌘		

How to create CRs using this form:

Comprehensive information and tips about how to create CRs can be found at: http://www.3gpp.org/3G_Specs/CRs.htm. Below is a brief summary:

- 1) Fill out the above form. The symbols above marked ⌘ contain pop-up help information about the field that they are closest to.
- 2) Obtain the latest version for the release of the specification to which the change is proposed. Use the MS Word "revision marks" feature (also known as "track changes") when making the changes. All 3GPP specifications can be downloaded from the 3GPP server under <ftp://www.3gpp.org/specs/>. For the latest version, look for the directory name with the latest date e.g. 2000-09 contains the specifications resulting from the September 2000 TSG meetings.

- 3) With "track changes" disabled, paste the entire CR form (use CTRL-A to select it) into the specification just in front of the clause containing the first piece of changed text. Delete those parts of the specification which are not relevant to the change request

7.3 Demodulation of DCH in Multi-path Fading Propagation conditions

7.3.1 Single Link Performance

7.3.1.1 Definition and applicability

The receive characteristics of the Dedicated Channel (DCH) in different multi-path fading environments are determined by the Block Error Ratio (BLER) values. BLER is measured for the each of the individual data rate specified for the DPCH. DCH is mapped into in Dedicated Physical Channel (DPCH).

The UE shall be tested only according to the data rate, supported. The data-rate-corresponding requirements shall apply to the UE.

7.3.1.2 Conformance requirements

For the parameters specified in Table 7.3.1.1, 7.3.1.3, ~~7.3.1.5~~ and ~~7.3.1.7~~ and 7.3.1.9 the average downlink $\frac{DPCH_E_c}{I_{or}}$ power shall be below the specified value for the BLER shown in Table 7.3.1.2, 7.3.1.4, 7.3.1.6, ~~and 7.3.1.8~~ and 7.3.1.10. These requirements are applicable for TFCS size 16.

Table 7.3.1.1: DCH parameters in multi-path fading propagation conditions (Case 1)

Parameter	Test 1	Test 2	Test 3	Test 4	Unit
Phase reference	P-CPICH				
\hat{I}_{or}/I_{oc}	9				dB
I_{oc}	-60				dBm / 3.84 MHz
Information Data Rate	12.2	64	144	384	kbps

Table 7.3.1.2: DCH requirements in multi-path fading propagation conditions (Case 1)

Test Number	$\frac{DPCH_E_c}{I_{or}}$	BLER
1	-15.0 dB	10^{-2}
2	-13.9 dB	10^{-1}
	-10.0 dB	10^{-2}
3	-10.6 dB	10^{-1}
	-6.8 dB	10^{-2}
4	-6.3 dB	10^{-1}
	-2.2 dB	10^{-2}

Table 7.3.1.3: DCH parameters in multi-path fading propagation conditions (Case 2)

Parameter	Test 5	Test 6	Test 7	Test 8	Unit
Phase reference	P-CPICH				
\hat{I}_{or}/I_{oc}	-3	-3	3	6	dB
I_{oc}	-60				dBm / 3.84 MHz
Information Data Rate	12.2	64	144	384	kbps

Table 7.3.1.4: DCH requirements in multi-path fading propagation conditions (Case 2)

Test Number	$\frac{DPCH_E_c}{I_{or}}$	BLER
5	-7.7 dB	10^{-2}
6	-6.4 dB	10^{-1}
	-2.7 dB	10^{-2}
7	-8.1 dB	10^{-1}
	-5.1 dB	10^{-2}
8	-5.5 dB	10^{-1}
	-3.2 dB	10^{-2}

Table 7.3.1.5: DCH parameters in multi-path fading propagation conditions (Case 3)

Parameter	Test 9	Test 10	Test 11	Test 12	Unit
Phase reference	P-CPICH				
\hat{I}_{or}/I_{oc}	-3	-3	3	6	dB
I_{oc}	-60				dBm / 3.84 MHz
Information Data Rate	12.2	64	144	384	kbps

Table 7.3.1.6: DCH requirements in multi-path fading propagation conditions (Case 3)

Test Number	$\frac{DPCH_E_c}{I_{or}}$	BLER
9	-11.8 dB	10^{-2}
10	-8.1 dB	10^{-1}
	-7.4 dB	10^{-2}
	-6.8 dB	10^{-3}
11	-9.0 dB	10^{-1}
	-8.5 dB	10^{-2}
	-8.0 dB	10^{-3}
12	-5.9 dB	10^{-1}
	-5.1 dB	10^{-2}
	-4.4 dB	10^{-3}

Table 7.3.1.7: DCH parameters in multi-path fading propagation conditions (Case 1) with S-CPICH

Parameter	Test 13	Test 14	Test 15	Test 16	Unit
Phase reference	S-CPICH				
\hat{I}_{or}/I_{oc}	9				dB
I_{oc}	-60				dBm / 3.84 MHz
Information Data Rate	12.2	64	144	384	kbps

Table 7.3.1.8: DCH requirements in multi-path fading propagation conditions (Case 1) with S-CPICH

Test Number	$\frac{DPCH_E_c}{I_{or}}$	BLER
13	-15.0 dB	10^{-2}
14	-13.9 dB	10^{-1}
	-10.0 dB	10^{-2}
15	-10.6 dB	10^{-1}
	-6.8 dB	10^{-2}
16	-6.3 dB	10^{-1}
	-2.2 dB	10^{-2}

Table 7.3.1.9: DCH parameters in multi-path fading propagation conditions (Case 6)

Parameter	Test 9	Test 10	Test 11	Test 12	Unit
Phase reference	P-CPICH				
\hat{I}_{or}/I_{oc}	-3	-3	3	6	dB
I_{oc}	-60				dBm / 3.84 MHz
Information Data Rate	12.2	64	144	384	kbps

Table 7.3.1.10: DCH requirements in multi-path fading propagation conditions (Case 6)

Test Number	$\frac{DPCH_E_c}{I_{or}}$	BLER
9	-8.8 dB	10^{-2}
10	-5.1 dB	10^{-1}
	-4.4 dB	10^{-2}
	-3.8 dB	10^{-3}
11	-6.0 dB	10^{-1}
	-5.5 dB	10^{-2}
	-5.0 dB	10^{-3}
12	-2.9 dB	10^{-1}
	-2.1 dB	10^{-2}
	-1.4 dB	10^{-3}

The reference for this requirement is [1] TS 25.101 subclause 8.3.1.1.

7.3.1.3 Test purpose

To verify the ability of the receiver to receive a predefined test signal, representing a multi-path fading propagation channel for the wanted and for the co-channel signals from serving and adjacent cells, with a BLER not exceeding a specified value.

7.3.1.4 Method of test

7.3.1.4.1 Initial conditions

1. Connect the SS, multi-path fading simulator and an AWGN noise source to the UE antenna connector as shown in Figure A.10.
2. Set up a call according to the Generic call setup procedure.
3. Set the test parameters for test 1-15 as specified Table 7.3.1.1, Table 7.3.1.3, Table 7.3.1.5, ~~and~~Table 7.3.1.7 and Table 7.3.1.9.
4. Enter the UE into loopback test mode and start the loopback test.
5. Setup fading simulators as fading condition case 1, case 2, case 3 and case 6, ~~to 3~~ which are described in Table D.2.2.1

7.3.1.4.2 Procedures

1. Measure BLER of DCH.

7.3.1.5 Test requirements

For the parameters specified in Table 7.3.1.1, Table 7.3.1.3, Table 7.3.1.5, ~~and~~Table 7.3.1.7 and Table 7.3.1.9 the BLER shall not exceed the value at the DPCH_Ec/Ior specified in Table 7.3.1.2, Table 7.3.1.4, Table 7.3.1.6, ~~and~~Table 7.3.1.8 and Table 7.3.1.10.

Annex D (normative): Propagation Conditions

D.1 General

D.2 Propagation Conditions

D.2.1 Static propagation condition

The propagation for the static performance measurement is an Additive White Gaussian Noise (AWGN) environment. No fading and multi-paths exist for this propagation model.

D.2.2 Multi-path fading propagation conditions

Table D.2.2.1 shows propagation conditions that are used for the performance measurements in multi-path fading environment. All taps have classical Doppler spectrum.

Table D.2.2.1: Propagation condition for multi-path fading environments

Case 1, speed 3km/h		Case 2, speed 3 km/h		Case 3, 120 km/h		Case 4, 3 km/h		Case 5, 50 km/h	
Relative Delay [ns]	Average Power [dB]	Relative Delay [ns]	Average Power [dB]	Relative Delay [ns]	Average Power [dB]	Relative Delay [ns]	Average Power [dB]	Relative Delay [ns]	Average Power [dB]
0	0	0	0	0	0	0	0	0	0
976	-10	976	0	260	-3	976	0	976	-10
		20000	0	524	-6				
				784	-9				

Table D.2.2.1: Propagation conditions for multi-path fading environments

Case 1, speed 3km/h		Case 2, speed 3 km/h		Case 3, speed 120 km/h		Case 4, speed 3 km/h		* Case 5, speed 50 km/h		Case 6, speed 250 km/h	
Relative Delay [ns]	Average Power [dB]	Relative Delay [ns]	Average Power [dB]	Relative Delay [ns]	Average Power [dB]	Relative Delay [ns]	Average Power [dB]	Relative Delay [ns]	Average Power [dB]	Relative Delay [ns]	Average Power [dB]
0	0	0	0	0	0	0	0	0	0	0	0
976	-10	976	0	260	-3	976	0	976	-10	260	-3
		20000	0	524	-6					524	-6
				784	-9					784	-9

Note Case 5 is only used in Requirements for support of RRM.

CHANGE REQUEST

⌘ **34.121** **CR 088** ⌘ rev **-** ⌘ Current version: **3.4.0** ⌘

For **HELP** on using this form, see bottom of this page or look at the pop-up text over the ⌘ symbols.

Proposed change affects: ⌘ (U)SIM ME/UE Radio Access Network Core Network

Title:	⌘ Removal of square brackets		
Source:	⌘ T1/RF		
Work item code:	⌘	Date:	⌘ 2001-5-14
Category:	⌘ F	Release:	⌘ R99
	<i>Use one of the following categories:</i> F (essential correction) A (corresponds to a correction in an earlier release) B (Addition of feature), C (Functional modification of feature) D (Editorial modification) Detailed explanations of the above categories can be found in 3GPP TR 21.900.		<i>Use one of the following releases:</i> 2 (GSM Phase 2) R96 (Release 1996) R97 (Release 1997) R98 (Release 1998) R99 (Release 1999) REL-4 (Release 4) REL-5 (Release 5)

Reason for change:	⌘ Square brackets were removed from test parameters and requirements in core specification TS 25.101.
Summary of change:	⌘ Title of clause 7.6 was changed (according to core specification). Square brackets were removed consistently with 25.101 CR91.
Consequences if not approved:	⌘ Inconsistency between core specification TS 25.101 and test specification TS 34.121.

Clauses affected:	⌘ 7.6, 7.8, 7.10	
Other specs Affected:	<input type="checkbox"/> Other core specifications ⌘ <input type="checkbox"/> Test specifications <input type="checkbox"/> O&M Specifications	⌘
Other comments:	⌘	

How to create CRs using this form:

Comprehensive information and tips about how to create CRs can be found at: http://www.3gpp.org/3G_Specs/CRs.htm. Below is a brief summary:

- 1) Fill out the above form. The symbols above marked ⌘ contain pop-up help information about the field that they are closest to.
- 2) Obtain the latest version for the release of the specification to which the change is proposed. Use the MS Word "revision marks" feature (also known as "track changes") when making the changes. All 3GPP specifications can be downloaded from the 3GPP server under <ftp://www.3gpp.org/specs/>. For the latest version, look for the directory name with the latest date e.g. 2000-09 contains the specifications resulting from the September 2000 TSG meetings.
- 3) With "track changes" disabled, paste the entire CR form (use CTRL-A to select it) into the specification just in front of the clause containing the first piece of changed text. Delete those parts of the specification which are not relevant to the change request

7.6 Demodulation of DCH in Base Station downlink Transmit diversity modes

7.6.1 Demodulation of DCH in open-loop transmit diversity mode

7.6.1.1 Definition and applicability

The receive characteristic of the Dedicated Channel (DCH) in open loop transmit diversity mode is determined by the Block Error Ratio (BLER). DCH is mapped into in Dedicated Physical Channel (DPCH).

The requirements and this test apply to all types of UTRA for the FDD UE.

7.6.1.2 Conformance requirements

For the parameters specified in Table 7.6.1.1 the average downlink $\frac{DPCH_E_c}{I_{or}}$ power shall be below the specified value for the BLER shown in Table 7.6.1.2.

Table 7.6.1.1: Test parameters for DCH reception in a open-loop transmit diversity scheme (Propagation condition: Case 1)

Parameter	Test 1	Unit
Phase reference	P-CPICH	
\hat{I}_{or}/I_{oc}	9	dB
I_{oc}	-60	dBm / 3.84 MHz
Information data rate	12.2	kbps

Table 7.6.1.2: Test requirements for DCH reception in open-loop transmit diversity scheme

Test Number	$\frac{DPCH_E_c}{I_{or}}$ (antenna 1/2)	BLER
1	{-16.8 dB}	10^{-2}

The reference for this requirement is [1] TS 25.101 subclause 8.6.1.1.

10) Enter the UE into loopback test mode and start the loopback test.

11) Perform the following steps a) to d) [15] times:

- a) Before proceeding with step b), set the output power of the UE, measured at the UE antenna connector, to be in the range -10 ± 9 dBm. This may be achieved by generating suitable downlink TPC commands from the SSs.
- b) Send the following sequences of TPC commands in the downlink from each SS over a period of 33 timeslots:

	Downlink TPC commands
SS1	1 0 0 1 1 0 0 1 1 0 0 1 1 0 0 1 1 0 0 1 1 0 0 1 1 0 0 1 1 0 0 1 1
SS2	1 0 1 0 1 0 1 0 1 0 1 0 1 0 1 0 1 0 1 0 1 0 1 0 1 0 1 0 1 0 1 0 1 0 1 0 1 0 1

- c) Measure the average output power at the UE antenna connector in each timeslot, not including the 25μ s transient periods at the start and end of each slot.
- d) For each timeslot from the 2nd timeslot to the 33rd timeslot inclusive:
 - if the average power in that timeslot is greater than or equal to the average power in the previous timeslot plus 0.5dB, increment “Transmitted power UP” by 1;
 - if the average power in that timeslot is less than or equal to the average power in the previous timeslot minus 0.5dB, increment “Transmitted power DOWN” by 1.

7.7.2.5 Test requirements

- 1) In Step 2) of subclause 7.7.2.4.2, the average power in slot #1 shall be less than or equal to the average power in slot #0 minus 0.5dB.
- 2) In Step 2) of subclause 7.7.2.4.2, the average power in slot #2 shall be less than or equal to the average power in slot #1 minus 0.5dB.
- 3) In Step 2) of subclause 7.7.2.4.2, the average power in slot #3 shall be less than or equal to the average power in slot #2 minus 0.5dB.
- 4) In Step 2) of subclause 7.7.2.4.2, the average power in slot #4 shall be greater than or equal to the average power in slot #3 plus 0.5dB.
- 5) At the end of the test, "Transmitted power UP" shall be greater than or equal to [95] and "Transmitted power DOWN" shall be greater than or equal to [210].

NOTE: The test limits in requirements (4) and (5) have been computed to give a confidence level of [99.7]% that a UE which follows the core requirements will pass. The number of timeslots has been chosen to get a good compromise between the test time and the risk of passing a bad UE.

7.8 Power control in downlink

Power control in the downlink is the ability of the UE receiver to converge to required link quality set by the network while using as low power as possible in downlink. If a BLER target has been assigned to a DCCH (See Annex C.3), then it has to be such that outer loop is based on DTCH and not on DCCH.

7.8.1 Power control in the downlink, constant BLER target

7.8.1.1 Definition and applicability

Power control in the downlink is the ability of the UE receiver to converge to required link quality set by the network while using as low power as possible in downlink. If a BLER target has been assigned to a DCCH (See Annex C.3), then it has to be such that outer loop is based on DTCH and not on DCCH. The requirements and this test apply to all types of UTRA for the FDD UE.

7.8.1.2 Conformance requirements

For the parameters specified in Table 7.8.1.1 the downlink $\frac{DPCH_E_c}{I_{or}}$ power measured values, which are averaged over one slot, shall be below the specified value in Table 7.8.1.2 more than 90% of the time. BLER shall be as shown in Table 7.8.1.2. Power control in downlink is ON during the test.

Table 7.8.1.1: Test parameter for downlink power control, constant BLER target

Parameter	Test 1	Test 2	Unit
\hat{I}_{or}/I_{oc}	9	-1	dB
I_{oc}	-60		dBm / 3.84 MHz
Information Data Rate	12.2		kbps
Target quality on DTCH	0.01		BLER
Propagation condition	Case 4		
Maximum_DL_Power *	7		dB
Minimum_DL_Power *	-18		dB
Limited_Power_Raise_Used	"Not used"		-

Note *: Power is compared to P-CPICH as specified in [9].

Table 7.8.1.2: Requirements in downlink power control, constant BLER target

Parameter	Test 1	Test 2	Unit
$\frac{DPCH_E_c}{I_{or}}$	-16.0	-9.0	dB
Measured quality on DTCH	0.01±30%	0.01±30%	BLER

The reference for this requirement is [1] TS 25.101 subclause 8.8.1.1.

7.8.1.3 Test purpose

To verify that the UE receiver is capable of converging to required link quality set by network while using as low power as possible.

7.8.1.4 Method of test

7.8.1.4.1 Initial conditions

- 1) Connect SS, multipath fading simulator and an AWGN source to the UE antenna connector as shown in Figure A.10.
- 2) Set up a call according to the Generic call setup procedure.
- 3) RF parameters are set up according to Table 7.8.1.1.
- 4) Enter the UE into loopback test mode and start the loopback test.
- 5) SS signals to UE target quality value on DTCH as specified in Table 7.8.1.1. SS will vary the physical channel power in downlink according to the TPC commands from UE. SS response time for UE TPC commands shall be one slot. At the same time BLER is measured. This is continued until the target quality value on DTCH is met, within the minimum accuracy requirement.

See [3] TS 34.108 and [4] TS 34.109 for details regarding generic call setup procedure and loopback test.

7.8.1.4.2 Procedure

- 1) After the target quality on DTCH is met, BLER is measured. Simultaneously the downlink $\frac{DPCH - E_c}{I_{or}}$ power averaged over one slot is measured. This is repeated until adequate amount of measurements is done to reach the required confidence level.
- 2) The measured quality on DTCH (BLER) and the measured downlink $\frac{DPCH - E_c}{I_{or}}$ power values averaged over one slot are compared to limits in Table 7.8.1.2.

7.8.1.5 Test Requirements

- a) The measured quality on DTCH does not exceed the values in Table 7.8.1.2.
- b) The downlink $\frac{DPCH - E_c}{I_{or}}$ power values, which are averaged over one slot, shall be below the values in Table 7.8.1.2 more than 90% of the time.

7.8.2 Power control in the downlink, initial convergence

7.8.2.1 Definition and applicability

This requirement verifies that DL power control works properly during the first seconds after DPCH connection is established. The requirements and this test apply to all types of UTRA for the FDD UE.

7.8.2.2 Conformance requirements

For the parameters specified in Table 7.8.2.1 the downlink DPCH_Ec/Ior power measured values, which are averaged over {50 ms}, shall be within the range specified in Table 7.8.2.2 more than 90% of the time. T1 equals to {500 ms} and it starts {10 ms} after the DPDCH connection is initiated. T2 equals to {500 ms} and it starts when T1 has expired. Power control is ON during the test.

Table 7.8.2.1: Test parameters for downlink power control, initial convergence

Parameter	Test 1	Test 2	Test 3	Test 4	Unit
Target quality value on DTCH	0.01	0.01	0.1	0.1	BLER
Initial DPCH_Ec/Ior	-5.9	-25.9	-2.1	-22.1	dB
Information Data Rate	12.2	12.2	64	64	kbps
\hat{I}_{or}/I_{oc}	-1				dB
I_{oc}	-60				dBm/3.84 MHz
Propagation condition	{Static}				
Maximum_DL_Power *	7				dB
Minimum_DL_Power *	-18				dB
Limited_Power_Raise_Used	"Not used"				

Note *: Power is compared to P-CPICH as specified in [9]

Table 7.8.2.2: Requirements in downlink power control, initial convergence

Parameter	Test 1 and Test 2	Test 3 and Test 4	Unit
$\frac{DPCH_E_c}{I_{or}}$ during T1	$\{-18.9 \leq DPCH_Ec/lor \leq -11.9\}$	$\{-15.1 \leq DPCH_Ec/lor \leq -8.1\}$	dB
$\frac{DPCH_E_c}{I_{or}}$ during T2	$\{-18.9 \leq DPCH_Ec/lor \leq -14.9\}$	$\{-15.1 \leq DPCH_Ec/lor \leq -11.1\}$	dB

The reference for this requirement is [1] TS 25.101 subclause 8.8.2.1.

7.8.2.3 Test purpose

To verify that DL power control works properly during the first seconds after DPCH connection is established.

7.8.2.4 Method of test

7.8.2.4.1 Initial conditions

- 1) Connect SS, multipath fading simulator and an AWGN source to the UE antenna connector as shown in Figure A.10.

7.8.2.4.2 Procedure

- 1) Set up call using test parameters according to Table 7.8.2.1.
- 2) Measure $\frac{DPCH_E_c}{I_{or}}$ power averaged over $\{50\text{ ms}\}$ during T1. T1 starts $\{10\text{ ms}\}$ after DPCH connection is initiated and T1 equals to $\{500\text{ ms}\}$
- 3) Measure $\frac{DPCH_E_c}{I_{or}}$ power averaged over $\{50\text{ ms}\}$ during T2. T2 starts, when T1 has expired and T2 equals to $\{500\text{ ms}\}$

7.8.2.5 Test Requirements

- a) The downlink $\frac{DPCH_E_c}{I_{or}}$ power values shall be within the range specified in Table 7.8.2.2 during T1 more than 90% of the time.
- b) The downlink $\frac{DPCH_E_c}{I_{or}}$ power values shall be within the range specified in Table 7.8.2.2 during T2 more than 90% of the time.

7.8.3 Power control in the downlink, wind up effects

7.8.3.1 Definition and applicability

This requirement verifies that, after the downlink maximum power is limited in the UTRAN and it has been released again, the downlink power control in the UE does not have a wind up effect, i.e. the required DL power has increased during time period the DL power was limited. The requirements and this test apply to all types of UTRA for the FDD UE.

7.8.3.2 Conformance requirements

This test is run in three stages where stage 1 is for convergence of the power control loop, in stage two the maximum downlink power for the dedicated channel is limited not to be higher than the parameter specified in Table 7.8.3.1. All parameters used in the three stages are specified in Table 7.8.3.1. The downlink $\frac{DPCH_E_c}{I_{or}}$ power measured values,

which are averaged over one slot, during stage 3 shall be lower than the value specified in Table 7.8.3.2 more than 90% of the time. Power control of the UE is ON during the test.

Table 7.8.3.1: Test parameter for downlink power control, wind-up effects

Parameter	Test 1			Unit
	Stage 1	Stage 2	Stage 3	
Time in each stage	>15	5	0.5	s
\hat{I}_{or}/I_{oc}	5			dB
I_{oc}	-60			dBm/3.84 MHz
Information Data Rate	12.2			kbps
Quality target on DTCH	0.01			BLER
Propagation condition	Case 4			
Maximum_DL_Power *	7	-6.2	7	dB
Minimum_DL_Power *	-18			dB
Limited_Power_Raise_Used	"Not used"			-

Note *: Power is compared to P-CPICH as specified in [9]

Table 7.8.3.2: Requirements in downlink power control, wind-up effects

Parameter	Test 1, stage 3	Unit
$\frac{DPCH_E_c}{I_{or}}$	{-13.3}	dB

The reference for this requirement is [1] TS 25.101 subclause 8.8.3.1.

7.9.1.4.2 Procedure

- 1) Test 1: Measure quality on DTCH and $\frac{DPCH_E_c}{I_{or}}$ power values averaged over one slot.
- 2) Test 2: Measure quality on DTCH and quality of compressed and recovery frames.
- 3) Test 3: Measure quality on DTCH and $\frac{DPCH_E_c}{I_{or}}$ power values averaged over one slot.
- 4) Test 4: Measure quality on DTCH and quality of compressed and recovery frames.

7.9.1.5 Test requirements

- a) Test 1: The downlink $\frac{DPCH_E_c}{I_{or}}$ power values averaged over one slot shall be below the values in Table 7.9.2 more than 90% of the time. The measured quality on DTCH shall be as required in Table 7.9.2.
- b) Test 2: Measured quality on DTCH and measured quality of compressed and recovery frames do not exceed the values in Table 7.9.2.
- c) Test3: The downlink $\frac{DPCH_E_c}{I_{or}}$ power values averaged over one slot shall be below the values in Table 7.9.2 more than 90% of the time. The measured quality on DTCH shall be as required in Table 7.9.2.
- d) Test 4: Measured quality on DTCH and measured quality of compressed and recovery frames do not exceed the values in Table 7.9.2.

7.10 Blind transport format detection

7.10.1 Definition and applicability

Performance of Blind transport format detection is determined by the Block Error Ratio (BLER) values and by the measured average transmitted DPCH_Ec/Ior value.

7.10.2 Conformance requirements

For the parameters specified in Table 7.10.1 the average downlink $\frac{DPCH_E_c}{I_{or}}$ power shall be below the specified value for the BLER and FDR shown in Table 7.10.2.

Table 7.10.1: Test parameters for Blind transport format detection

Parameter	Test 1	Test 2	Test 3	Test 4	Test 5	Test 6	Unit
\hat{I}_{or}/I_{oc}	-1			-3			dB
I_{oc}	-60						dBm / 3.84 MHz
Information Data Rate	12.2 (rate 1)	7.95 (rate 2)	1.95 (rate 3)	12.2 (rate 1)	7.95 (rate 2)	1.95 (rate 3)	kbps
propagation condition	static			multi-path fading case 3			-
TFCI	off						-

Table 7.10.2: The Requirements for DCH reception in Blind transport format detection

Test Number	$\frac{DPCH_E_c}{I_{or}}$	BLER	FDR
1	{-17.7dB}	10^{-2}	10^{-4}
2	{-17.8dB}	10^{-2}	10^{-4}
3	{-18.4dB}	10^{-2}	10^{-4}
4	{-13.0dB}	10^{-2}	10^{-4}
5	{-13.2dB}	10^{-2}	10^{-4}
6	{-13.8dB}	10^{-2}	10^{-4}

* The value of DPCH_Ec/I_{or}, I_{oc}, and I_{or}/I_{oc} are defined in case of DPCH is transmitted

Note: In the test, 9 deferent Transport Format Combinations (Table.7.10.3) are sent during the call set up procedure, so that UE has to detect correct transport format in this 9 candidates.

Table.7.10.3: Transport format combinations informed during the call set up procedure in the test

	1	2	3	4	5	6	7	8	9
DTCH	12.2k	10.2k	7.95k	7.4k	6.7k	5.9k	5.15k	4.75k	1.95k
DCCH					2.4k				

7.10.3 Test purpose

To verify the ability of the blind transport format detection to receive a predefined test signal, representing a static propagation channel for the wanted and for the co-channel signals from serving and adjacent cells, with a block error ratio (BLER) and false transport format detection ratio (FDR) not exceeding a specified value.

To verify the ability of the blind transport format detection to receive a predefined test signal, representing a multi-path propagation channel for the wanted and for the co-channel signals from serving and adjacent cells, with a block error ratio (BLER) and false transport format detection ratio (FDR) not exceeding a specified value.

7.10.4 Method of test

7.10.4.1 Initial conditions

1. Connect the SS and AWGN noise source to the UE antenna connector as shown in Figure A.9 in the case for test 1-3. Connect the SS, multipath fading simulator and an AWGN noise source to the UE antenna connector as shown in Figure A.10 in the case of test 4-6.
2. Set up a call according to the Generic call setup procedure.
3. Set the test parameters for test 1-6 as specified Table 7.10.1 and Table 7.10.2.
4. Enter the UE into loopback test mode and start the loopback test.
5. In the case of test 4-6, Setup fading simulator as fading condition case 3 which are described in Table D.2.2.1.

7.10.4.2 Procedure

Measure BLER and FDR of DCH.

7.10.5 Test requirements

BLER and FDR shall not exceed the values at the DPCH_Ec/I_{or} specified in Table 7.10.2.

CHANGE REQUEST

⌘ **TS 34.121 CR 089** ⌘ rev **-** ⌘ Current version: **3.4.0** ⌘

For **HELP** on using this form, see bottom of this page or look at the pop-up text over the ⌘ symbols.

Proposed change affects: ⌘ (U)SIM ME/UE Radio Access Network Core Network

Title:	⌘ Transmit power level during Receiver characteristics test		
Source:	⌘ T1/RF		
Work item code:	⌘	Date:	⌘ 14 May 2001
Category:	⌘ F	Release:	⌘ R99
<p>Use <u>one</u> of the following categories:</p> <p>F (essential correction) A (corresponds to a correction in an earlier release) B (Addition of feature), C (Functional modification of feature) D (Editorial modification)</p> <p>Detailed explanations of the above categories can be found in 3GPP TR 21.900.</p>		<p>Use <u>one</u> of the following releases:</p> <p>2 (GSM Phase 2) R96 (Release 1996) R97 (Release 1997) R98 (Release 1998) R99 (Release 1999) REL-4 (Release 4) REL-5 (Release 5)</p>	

Reason for change:	⌘ UE transmit power levels during measurements on Receiver characteristics are clearly defined in the core specification, TS25.101 V3.6.0.		
Summary of change:	⌘ Introduction of the transmit power levels as additional test parameters for applicable Receiver characteristics tests		
Consequences if not approved:	⌘ Inconsistency with the core specification is left.		

Clauses affected:	⌘ 6.2, 6.3, 6.4, 6.5, 6.6 and 6.7		
Other specs affected:	<input type="checkbox"/> Other core specifications <input type="checkbox"/> Test specifications <input type="checkbox"/> O&M Specifications	⌘	
Other comments:	⌘		

How to create CRs using this form:

Comprehensive information and tips about how to create CRs can be found at: http://www.3gpp.org/3G_Specs/CRs.htm. Below is a brief summary:

- 1) Fill out the above form. The symbols above marked ⌘ contain pop-up help information about the field that they are closest to.
- 2) Obtain the latest version for the release of the specification to which the change is proposed. Use the MS Word "revision marks" feature (also known as "track changes") when making the changes. All 3GPP specifications can be downloaded from the 3GPP server under <ftp://www.3gpp.org/specs/> For the latest version, look for the directory name with the latest date e.g. 2000-09 contains the specifications resulting from the September 2000 TSG meetings.
- 3) With "track changes" disabled, paste the entire CR form (use CTRL-A to select it) into the specification just in front of the clause containing the first piece of changed text. Delete those parts of the specification which are not relevant to the change request.

6 Receiver Characteristics

6.1 General

Receiving performance test of the UE is implemented during communicating with the SS via air interface. The procedure is using normal call protocol until the UE is communicating on traffic channel basically. On the traffic channel, the UE provides special function for testing that is called Logical Test Interface and the UE is tested using this function (Refer to [4] TS 34.109)

Transmitting or receiving bit/symbol rate for test channel is shown in Table 6.1.

Table 6.1: Bit / Symbol rate for Test Channel

Type of User Information	User bit rate	DL DPCH symbol rate	UL DPCH bit rate	Remarks
12.2 kbps reference measurement channel	12.2 kbps	30 ksps	60 kbps	Standard Test

Unless otherwise stated the receiver characteristics are specified at the antenna connector of the UE. For UE(s) with an integral antenna only, a reference antenna with a gain of 0 dBi is assumed. UE with an integral antenna may be taken into account by converting these power levels into field strength requirements, assuming a 0 dBi gain antenna. Receiver characteristics for UE(s) with multiple antennas/antenna connectors are FFS.

The UE antenna performance has a significant impact on system performance, and minimum requirements on the antenna efficiency are therefore intended to be included in future versions of this specification. It is recognised that different requirements and test methods are likely to be required for the different types of UE.

All the parameters in clause 6 are defined using the DL reference measurement channel (12.2 kbps) specified in subclause C.3.1 and unless stated otherwise, with DL power control OFF.

The common RF test conditions of Rx Characteristics are defined in Annex E.3.2, and each test conditions in this clause (clause 6) should refer Annex E.3.2. Individual test conditions are defined in the paragraph of each test.

6.2 Reference Sensitivity Level

6.2.1 Definition and applicability

The reference sensitivity is the minimum receiver input power measured at the antenna port at which the Bit Error Ratio (BER) does not exceed a specific value

The requirements and this test apply to all types of UTRA for the FDD UE.

6.2.2 Minimum Requirements

The BER shall not exceed 0.001 for the parameters specified in Table 6.2.1.

Table 6.2.1: Test parameters for Reference Sensitivity Level

Parameter	Level / Status	Unit
\hat{I}_{or}	-106.7	dBm / 3.84 MHz
DPCH_Ec	-117	dBm / 3.84 MHz
1. For Power class 3, this shall be at the maximum output power 2. For Power class 4, this shall be at the maximum output power		

The normative reference for this requirement is [1] TS 25.101 subclause 7.3.1.

6.2.3 Test purpose

To verify that the UE BER does not exceed 0.001 for the parameters specified in Table 6.2.

The lack of the reception sensitivity decreases the coverage area at the far side from Node B.

6.2.4 Method of test

6.2.4.1 Initial conditions

- 1) Connect the SS to the UE antenna connector as shown in Figure A.3.
- 2) A call is set up according to the Generic call setup procedure, and RF parameters are set up according to Table 6.2.2.
- 3) Enter the UE into loopback test mode and start the loopback test.

See [3] TS 34.108 and [4] TS 34.109 for details regarding generic call setup procedure and loopback test.

6.2.4.2 Procedure

- 1) Set and send continuously Up power control commands to the UE until the UE output power shall be maximum level.
- 2) Measure the BER of DCH received from the UE at the SS.

6.2.5 Test requirements

The measured BER, derived in step 2), shall not exceed 0.001.

Table 6.2.2: Test parameters for Reference Sensitivity Level

Parameter	Level / Status	Unit
\hat{I}_{or}	-106	dBm / 3.84 MHz
DPCH_Ec	-116.3	dBm / 3.84 MHz
1. For Power class 3, this shall be at the maximum output power 2. For Power class 4, this shall be at the maximum output power		

NOTE: If the above Test Requirement differs from the Minimum Requirement then the Test Tolerance applied for this test is non-zero. The Test Tolerance for this test is defined in Annex F.2 and the explanation of how the Minimum Requirement has been relaxed by the Test Tolerance is given in Annex F.4.

6.3 Maximum Input Level

6.3.1 Definition and applicability

This is defined as the maximum receiver input power at the UE antenna port which does not degrade the specified BER performance.

The requirements and this test apply to all types of UTRA for the FDD UE.

6.3.2 Conformance requirements

The BER shall not exceed 0.001 for the parameters specified in Table 6.3.

The reference for this requirement is [1] TS 25.101 subclause 7.4.1.

NOTE: Since the spreading factor is large ($10\log(SF)=21\text{dB}$), the majority of the total input signal consists of the OCNS interference. The structure of OCNS signal is defined in Annex E.3.2.

6.3.3 Test purpose

To verify that the UE BER does not exceed 0.001 for the parameters specified in Table 6.3.

The lack of the maximum input level decreases the coverage area at the near side from Node B.

6.3.4 Method of test

6.3.4.1 Initial conditions

- 1) Connect the SS to the UE antenna connector as shown in Figure A.3.
- 2) A call is set up according to the Generic call setup procedure, and RF parameters are set up according to Table 6.3 and Table E.3.3.
- 3) Enter the UE into loopback test mode and start the loopback test.

See [3] TS 34.108 and [4] TS 34.109 for details regarding generic call setup procedure and loopback test.

Table 6.3: Test parameters for Maximum Input Level

Parameter	Level / Status	Unit
\hat{I}_{or}	-25	dBm / 3.84MHz
$\frac{DPCH_E_c}{I_{or}}$	-19	dB
1. For Power class 3, the average transmit output power shall be +20 dBm 2. For Power class 4, the average transmit output power shall be +18 dBm		

6.3.4.2 Procedure

- 1) Measure the BER of DCH received from the UE at the SS.

6.3.5 Test requirements

The measured BER, derived in step 1), shall not exceed 0.001.

6.4 Adjacent Channel Selectivity (ACS)

6.4.1 Definition and applicability

Adjacent Channel Selectivity (ACS) is a measure of a receiver's ability to receive a W-CDMA signal at its assigned channel frequency in the presence of an adjacent channel signal at a given frequency offset from the centre frequency of the assigned channel. ACS is the ratio of the receive filter attenuation on the assigned channel frequency to the receive filter attenuation on the adjacent channel(s).

The requirements and this test apply to all types of UTRA for the FDD UE.

6.4.2 Minimum Requirements

For the UE of power class 3 and 4, the BER shall not exceed 0.001 for the parameters specified in Table 6.4.1. This test condition is equivalent to the ACS value 33 dB.

Table 6.4.1: Test parameters for Adjacent Channel Selectivity

Parameter	Level / Status	Unit
DPCH_Ec	-103	dBm / 3.84 MHz
I _{or}	-92.7	dBm / 3.84 MHz
I _{oac} (modulated)	-52	dBm / 3.84 MHz
F _{uw} (offset)	-5 or +5	MHz
1. For Power class 3, the average transmit output power shall be +20 dBm 2. For Power class 4, the average transmit output power shall be +18 dBm		

The normative reference for this requirement is [1] TS 25.101 subclause 7.5.1.

Note: The I_{oac} (modulated) signal consists of common channels needed for tests and 16 dedicated data channels. The channelisation codes for data channels are chosen optimally to reduce peak to average ratio (PAR). All dedicated channels user data is uncorrelated to each other.

6.4.3 Test purpose

To verify that the UE BER does not exceed 0.001 for the test parameters specified in Table 6.4.1.

The lack of the ACS decreases the coverage area when other transmitter exists in the adjacent channel.

6.4.4 Method of test

6.4.4.1 Initial conditions

- 1) Connect the SS to the UE antenna connector as shown in Figure A.4.
- 2) A call is set up according to the Generic call setup procedure, and RF parameters are set up according to Table 6.4.2.
- 3) Enter the UE into loopback test mode and start the loopback test.

See [3] TS 34.108 and [4] TS 34.109 for details regarding generic call setup procedure and loopback test.

6.4.4.2 Procedure

- 1) Set the parameters of the interference signal generator as shown in Table 6.4.2.
- 2) Measure the BER of DCH received from the UE at the SS.

6.4.5 Test requirements

The measured BER, derived in step 1), shall not exceed 0.001.

Table 6.4.2: Test parameters for Adjacent Channel Selectivity

Parameter	Level / Status	Unit
DPCH_Ec	-103	dBm / 3.84 MHz
I_{or}	-92.7	dBm / 3.84 MHz
I_{oac} (modulated)	-52	dBm / 3.84 MHz
F_{uw} (offset)	-5 or +5	MHz
1. For Power class 3, the average transmit output power shall be +20 dBm 2. For Power class 4, the average transmit output power shall be +18 dBm		

NOTE: If the above Test Requirement differs from the Minimum Requirement then the Test Tolerance applied for this test is non-zero. The Test Tolerance for this test is defined in Annex F.2 and the explanation of how the Minimum Requirement has been relaxed by the Test Tolerance is given in Annex F.4.

6.5 Blocking Characteristics

6.5.1 Definition and applicability

The blocking characteristic is a measure of the receiver's ability to receive a wanted signal at its assigned channel frequency in the presence of an unwanted interferer on frequencies other than those of the spurious response or the adjacent channels, without this unwanted input signal causing a degradation of the performance of the receiver beyond a specified limit. The blocking performance shall apply at all frequencies except those at which a spurious response occur.

The requirements and this test apply to all types of UTRA for the FDD UE.

6.5.2 Minimum Requirements

The BER shall not exceed 0.001 for the parameters specified in Table 6.5.1 and Table 6.5.2. For Table 6.5.2 up to (24) exceptions are allowed for spurious response frequencies in each assigned frequency channel when measured using a 1 MHz step size.

The normative reference for this requirement is [1] TS 25.101 subclause 7.6.1.

Note: $I_{blocking}$ (modulated) consists of common channels and 16 dedicated data channels. The channelisation codes for data channels are chosen optimally to reduce peak to average ratio (PAR). All dedicated channels user data is uncorrelated to each other.

Table 6.5.1: Test parameters for In-band blocking characteristics

Parameter	10 MHz offset	15 MHz offset	Unit
DPCH_Ec	-114	-114	dBm / 3.84 MHz
I_{or}	-103.7	-103.7	dBm / 3.84 MHz
$I_{blocking}$ (modulated)	-56	-44	dBm / 3.84 MHz
F_{uw} (offset)	+10 or -10	+15 or -15	MHz
1. For Power class 3, the average transmit output power shall be +20 dBm 2. For Power class 4, the average transmit output power shall be +18 dBm			

Table 6.5.2: Test parameters for Out of band blocking characteristics

Parameter	Band 1	Band 2	Band 3	Unit
DPCH_Ec	-114	-114	-114	dBm / 3.84MHz
\uparrow or	-103.7	-103.7	-103.7	dBm / 3.84MHz
I _{blocking} (CW)	-44	-30	-15	dBm
F _{uw} For operation in frequency bands as defined in subclause 4.2(a)	2050 < f < 2095 2185 < f < 2230	2025 < f < 2050 2230 < f < 2255	1 < f < 2025 2255 < f < 12750	MHz
F _{uw} For operation in frequency bands as defined in subclause 4.2(b)	1870 < f < 1915 2005 < f < 2050	1845 < f < 1870 2050 < f < 2075	1 < f < 1845 2075 < f < 12750	MHz
1. For Power class 3, the average transmit output power shall be +20 dBm 2. For Power class 4, the average transmit output power shall be +18 dBm				

NOTE:

- For operation in bands referenced in 4.2(a), from 2095 < f < 2110 MHz and 2170 < f < 2185 MHz, the appropriate in-band blocking or adjacent channel selectivity in subclause 6.4.2 shall be applied.
- For operation in bands referenced in 4.2(b), 1915 < f < 1930 MHz and 1990 < f < 2005 MHz, the appropriate in-band blocking or adjacent channel selectivity in subclause 6.4.2 shall be applied.

6.5.3 Test purpose

To verify that the UE BER does not exceed 0.001 for the parameters specified in Table 6.5.1 and Table 6.5.2. For Table 6.5.2 up to (24) exceptions are allowed for spurious response frequencies in each assigned frequency channel when measured using a 1 MHz step size.

The lack of the blocking ability decreases the coverage area when other transmitter exists (except in the adjacent channels and spurious response).

6.5.4 Method of test

6.5.4.1 Initial conditions

- Connect the SS to the UE antenna connector as shown in Figure A.5.
- A call is set up according to the Generic call setup procedure, and RF parameters are set up according to Table 6.5.3 and Table 6.5.4.
- Enter the UE into loopback test mode and start the loopback test.

See [3] TS 34.108 and [4] TS 34.109 for details regarding generic call setup procedure and loopback test.

6.5.4.2 Procedure

- Set the parameters of the CW generator or the interference signal generator as shown in Table 6.5.3 and Table 6.5.4. For Table 6.5.4, the frequency step size is 1 MHz.
- Measure the BER of DCH received from the UE at the SS.
- For Table 6.5.4, record the frequencies for which BER exceed the test requirements.

6.5.5 Test requirements

For Table 6.5.3, the measured BER, derived in step 2), shall not exceed 0.001. For Table 6.5.4, the measured BER, derived in step 2) shall not exceed 0.001 except for the spurious response frequencies, recorded in step 3). The number of spurious response frequencies, recorded in step 3) shall not exceed 24.

Table 6.5.3: Test parameters for In-band blocking characteristics

Parameter	10 MHz offset	15 MHz offset	Unit
DPCH_Ec	-114	-114	dBm / 3.84 MHz
\hat{I}_{or}	-103.7	-103.7	dBm / 3.84 MHz
$I_{blocking}$ (modulated)	-56	-44	dBm / 3.84 MHz
F_{uw} (offset)	+10 or -10	+15 or -15	MHz
1. For Power class 3, the average transmit output power shall be +20 dBm 2. For Power class 4, the average transmit output power shall be +18 dBm			

Table 6.5.4: Test parameters for Out of band blocking characteristics

Parameter	Band 1	Band 2	Band 3	Unit
DPCH_Ec	-114	-114	-114	dBm / 3.84MHz
\hat{I}_{or}	-103.7	-103.7	-103.7	dBm / 3.84MHz
$I_{blocking}$ (CW)	-44	-30	-15	dBm
F_{uw} For operation in frequency bands as defined in subclause 4.2(a)	2050 < f < 2095 2185 < f < 2230	2025 < f < 2050 2230 < f < 2255	1 < f < 2025 2255 < f < 12750	MHz
F_{uw} For operation in frequency bands as defined in subclause 4.2(b)	1870 < f < 1915 2005 < f < 2050	1845 < f < 1870 2050 < f < 2075	1 < f < 1845 2075 < f < 12750	MHz
1. For Power class 3, the average transmit output power shall be +20 dBm 2. For Power class 4, the average transmit output power shall be +18 dBm				

NOTE:

- For operation in bands referenced in 4.2(a), from 2095 < f < 2110 MHz and 2170 < f < 2185 MHz, the appropriate in-band blocking or adjacent channel selectivity in subclause 6.4.2 shall be applied.
- For operation in bands referenced in 4.2(b), 1915 < f < 1930 MHz and 1990 < f < 2005 MHz, the appropriate in-band blocking or adjacent channel selectivity in subclause 6.4.2 shall be applied.
- If the above Test Requirement differs from the Minimum Requirement then the Test Tolerance applied for this test is non-zero. The Test Tolerance for this test is defined in Annex F.2 and the explanation of how the Minimum Requirement has been relaxed by the Test Tolerance is given in Annex F.4.

6.6 Spurious Response

6.6.1 Definition and applicability

Spurious response is a measure of the receiver's ability to receive a wanted signal on its assigned channel frequency without exceeding a given degradation due to the presence of an unwanted CW interfering signal at any other frequency at which a response is obtained i.e. for which the blocking limit is not met.

The requirements and this test apply to all types of UTRA for the FDD UE.

6.6.2 Minimum Requirements

The BER shall not exceed 0.001 for the parameters specified in Table 6.6.1.

The normative reference for this requirement is [1] TS 25.101 subclause 7.7.1.

Table 6.6.1: Test parameters for Spurious Response

Parameter	Level	Unit
DPCH_Ec	-114	dBm / 3.84MHz
I_{or}	-103.7	dBm / 3.84MHz
$I_{blocking}(CW)$	-44	dBm
F_{uw}	Spurious response frequencies	MHz
1. For Power class 3, the average transmit output power shall be +20 dBm 2. For Power class 4, the average transmit output power shall be +18 dBm		

6.6.3 Test purpose

To verify that the UE BER does not exceed 0.001 for the parameters specified in Table 6.6.1.

The lack of the spurious response ability decreases the coverage area when other unwanted interfering signal exists at any other frequency.

6.6.4 Method of test

6.6.4.1 Initial conditions

- 1) Connect the SS to the UE antenna connector as shown in Figure A.6.
- 2) A call is set up according to the Generic call setup procedure, and RF parameters are set up according to Table 6.6.2.
- 3) Enter the UE into loopback test mode and start the loopback test.

See [3] TS 34.108 and [4] TS 34.109 for details regarding generic call setup procedure and loopback test.

6.6.4.2 Procedure

- 1) Set the parameter of the CW generator as shown in Table 6.6.2. The spurious response frequencies are determined in step 3) of section 6.5.4.2.
- 2) Measure the BER of DCH received from the UE at the SS.

6.6.5 Test requirements

The measured BER, derived in step 2), shall not exceed 0.001.

Table 6.6.2: Test parameters for Spurious Response

Parameter	Level	Unit
DPCH_Ec	-114	dBm / 3.84MHz
I _{or}	-103.7	dBm / 3.84MHz
I _{blocking} (CW)	-44	dBm
F _{uw}	Spurious response frequencies	MHz
1. For Power class 3, the average transmit output power shall be +20 dBm 2. For Power class 4, the average transmit output power shall be +18 dBm		

NOTE: If the above Test Requirement differs from the Minimum Requirement then the Test Tolerance applied for this test is non-zero. The Test Tolerance for this test is defined in Annex F.2 and the explanation of how the Minimum Requirement has been relaxed by the Test Tolerance is given in Annex F.4.

6.7 Intermodulation Characteristics

6.7.1 Definition and applicability

Third and higher order mixing of the two interfering RF signals can produce an interfering signal in the band of the desired channel. Intermodulation response rejection is a measure of the capability of the receiver to receiver a wanted signal on its assigned channel frequency in the presence of two or more interfering signals which have a specific frequency relationship to the wanted signal.

The requirements and this test apply to all types of UTRA for the FDD UE.

6.7.2 Minimum Requirements

The BER shall not exceed 0.001 for the parameters specified in Table 6.7.1.

The normative reference for this requirement is [1] TS 25.101 subclause 7.8.1.

Note: I_{ouw2} (modulated) consists of common channels and 16 dedicated data channels. The channelisation codes for data channels are chosen optimally to reduce peak to average ratio (PAR). All dedicated channels user data is uncorrelated to each other.

Table 6.7.1: Test parameters for Intermodulation Characteristics

Parameter	Level		Unit
DPCH_Ec	-114		dBm / 3.84 MHz
I _{or}	-103.7		dBm / 3.84 MHz
I _{ouw1} (CW)	-46		dBm
I _{ouw2} (modulated)	-46		dBm / 3.84 MHz
F _{uw1} (offset)	10	-10	MHz
F _{uw2} (offset)	20	-20	MHz
1. For Power class 3, the average transmit output power shall be +20 dBm 2. For Power class 4, the average transmit output power shall be +18 dBm			

6.7.3 Test purpose

To verify that the UE BER does not exceed 0.001 for the parameters specified in Table 6.7.1.

The lack of the intermodulation response rejection ability decreases the coverage area when two or more interfering signals, which have a specific frequency relationship to the wanted signal, exist.

6.7.4 Method of test

6.7.4.1 Initial conditions

- 1) Connect the SS to the UE antenna connector as shown in Figure A.7.
- 2) A call is set up according to the Generic call setup procedure, and RF parameters are set up according to Table 6.7.2.
- 3) Enter the UE into loopback test mode and start the loopback test.

See [3] TS 34.108 and [4] TS 34.109 for details regarding generic call setup procedure and loopback test.

6.7.4.2 Procedure

- 1) Set the parameters of the CW generator and interference signal generator as shown in Table 6.7.2.
- 2) Measure the BER of DCH received from the UE at the SS.

6.7.5 Test requirements

The measured BER, derived in step 1), shall not exceed 0.001.

Table 6.7.2: Test parameters for Intermodulation Characteristics

Parameter	Level		Unit
DPCH_Ec	-114		dBm / 3.84 MHz
I_{or}	-103.7		dBm / 3.84 MHz
I_{ouw1} (CW)	-46		dBm
I_{ouw2} (modulated)	-46		dBm / 3.84 MHz
F_{uw1} (offset)	10	-10	MHz
F_{uw2} (offset)	20	-20	MHz
1. For Power class 3, the average transmit output power shall be +20 dBm 2. For Power class 4, the average transmit output power shall be +18 dBm			

NOTE: If the above Test Requirement differs from the Minimum Requirement then the Test Tolerance applied for this test is non-zero. The Test Tolerance for this test is defined in Annex F.2 and the explanation of how the Minimum Requirement has been relaxed by the Test Tolerance is given in Annex F.4.

CR-Form-v3

CHANGE REQUEST

⌘ **34.121 CR 090** ⌘ rev **-** ⌘ Current version: **3.4.0** ⌘

For **HELP** on using this form, see bottom of this page or look at the pop-up text over the ⌘ symbols.

Proposed change affects: ⌘ (U)SIM ME/UE Radio Access Network Core Network

Title:	⌘ Correction of Definition of multi-code OCNS signal		
Source:	⌘ T1/RF		
Work item code:	⌘	Date:	⌘ 14, May, 2001
Category:	⌘ F	Release:	⌘ R99
	<i>Use one of the following categories:</i> F (essential correction) A (corresponds to a correction in an earlier release) B (Addition of feature), C (Functional modification of feature) D (Editorial modification)		<i>Use one of the following releases:</i> 2 (GSM Phase 2) R96 (Release 1996) R97 (Release 1997) R98 (Release 1998) R99 (Release 1999) REL-4 (Release 4) REL-5 (Release 5)
	Detailed explanations of the above categories can be found in 3GPP TR 21.900.		

Reason for change:	⌘ The current OCNS definition is not correct (Correspondent to TS25.101 CR92)		
Summary of change:	⌘ The current text includes a refernce from TS34.121 to TS25.141, which is formally incorrect. For that the reason the reference is removed and substituted by the corresponding table 6.2 from 25.141.		
Consequences if not approved:	⌘ The test results could depend on the OCNS signal that is used for the test.		

Clauses affected:	⌘ 2, E.3.3, E.3.4, and E.3.5		
Other specs affected:	<input type="checkbox"/> Other core specifications <input type="checkbox"/> Test specifications <input type="checkbox"/> O&M Specifications	⌘	
Other comments:	⌘		

How to create CRs using this form:

Comprehensive information and tips about how to create CRs can be found at: http://www.3gpp.org/3G_Specs/CRs.htm. Below is a brief summary:

- 1) Fill out the above form. The symbols above marked ⌘ contain pop-up help information about the field that they are closest to.
- 2) Obtain the latest version for the release of the specification to which the change is proposed. Use the MS Word "revision marks" feature (also known as "track changes") when making the changes. All 3GPP specifications can be downloaded from the 3GPP server under <ftp://www.3gpp.org/specs/>. For the latest version, look for the directory name with the latest date e.g. 2000-09 contains the specifications resulting from the September 2000 TSG meetings.
- 3) With "track changes" disabled, paste the entire CR form (use CTRL-A to select it) into the specification just in front of the clause containing the first piece of changed text. Delete those parts of the specification which are not relevant to the change request.

2 References

The following documents contain provisions which, through reference in this text, constitute provisions of the present document.

- References are either specific (identified by date of publication, edition number, version number, etc.) or non-specific.
- For a specific reference, subsequent revisions do not apply.
- For a non-specific reference, the latest version applies. In the case of a reference to a 3GPP document (including a GSM document), a non-specific reference implicitly refers to the latest version of that document in the same Release as the present document.

- [1] 3GPP TS 25.101 "UE Radio transmission and reception (FDD)".
- [2] 3GPP TS 25.133 "Requirements for Support of Radio Resource Management (FDD)".
- [3] 3GPP TS 34.108 "Common Test Environments for User Equipment (UE) Conformance Testing".
- [4] 3GPP TS 34.109 "Logical Test Interface; Special conformance testing functions".
- [5] 3GPP TS 25.214 "Physical layer procedures (FDD)".
- [6] 3GPP TR 21.905 "Vocabulary for 3GPP Specifications".
- [7] 3GPP TR 25.990 "Vocabulary".
- [8] 3GPP TS 25.331: "Radio Resource Control (RRC) Protocol Specification".
- [9] 3GPP TS 25.433 "UTRAN Iub Interface NBAP Signalling".
- [10] ~~void~~3GPP TS 25.141: "Base station conformance testing (FDD)"

E.3.3 Measurement of Performance requirements

Table E.3.3 is applicable for measurements on the Performance requirements (clause 7), including subclause 6.3 (Maximum input level), excluding subclauses 7.6.1 (Demodulation of DCH in open loop transmit diversity mode) and 7.6.2 (Demodulation of DCH in closed loop transmit diversity mode).

Table E.3.3: Downlink Physical Channels transmitted during a connection¹

Physical Channel	Power	Note
P-CPICH	$P\text{-CPICH_Ec/Ior} = -10 \text{ dB}$	Use of P-CPICH or S-CPICH as phase reference is specified for each requirement and is also set by higher layer signalling.
S-CPICH	$S\text{-CPICH_Ec/Ior} = -10 \text{ dB}$	When S-CPICH is the phase reference in a test condition, the phase of S-CPICH shall be 180 degrees offset from the phase of P-CPICH. When S-CPICH is not the phase reference, it is not transmitted.
P-CCPCH	$P\text{-CCPCH_Ec/Ior} = -12 \text{ dB}$	
SCH	$SCH_Ec/Ior = -12 \text{ dB}$	This power shall be divided equally between Primary and Secondary Synchronous channels
PICH	$PICH_Ec/Ior = -15 \text{ dB}$	
DPCH	Test dependent power	When S-CPICH is the phase reference in a test condition, the phase of DPCH shall be 180 degrees offset from the phase of P-CPICH.
OCNS	Necessary power so that total transmit power spectral density of Node B (Ior) adds to one	<ol style="list-style-type: none"> 1. OCNS interference consists of 16 dedicated data channels. The channelization codes, level settings and timing offsets for data channels are chosen as specified for the 16 DPCH channels of Test Model 4 in TS 25.441 [10] Table 6-2E.3.6. 2. All dedicated channels user data is uncorrelated to each other and the measurement channel during the BER/BLER measurement period.

Note 1: For dynamic power correction required to compensate for the presence of transient channels, e.g. control channels, a subset of the DPCH channels may be used.

¹ Power levels are based on the assumption that multipath propagation conditions and noise source representing interference from other cells Ioc are turned on after the call set-up phase.

E.3.4 Connection with open-loop transmit diversity mode

Table E.3.4 is applicable for measurements for subclause 7.6.1 (Demodulation of DCH in open loop transmit diversity mode)

Table E.3.4: Downlink Physical Channels transmitted during a connection²

Physical Channel	Power	Note
P-CPICH (antenna 1)	$P\text{-CPICH_Ec1/I_{or}} = -13 \text{ dB}$	1. Total $P\text{-CPICH_Ec/I_{or}} = -10 \text{ dB}$
P-CPICH (antenna 2)	$P\text{-CPICH_Ec2/I_{or}} = -13 \text{ dB}$	
P-CPICH (antenna 1)	$P\text{-CPICH_Ec1/I_{or}} = -13 \text{ dB}$	1. Total $P\text{-CPICH_Ec/I_{or}} = -10 \text{ dB}$
P-CPICH (antenna 2)	$P\text{-CPICH_Ec2/I_{or}} = -13 \text{ dB}$	
P-CCPCH (antenna 1)	$P\text{-CCPCH_Ec1/I_{or}} = -15 \text{ dB}$	1. STTD applied 2. Total $P\text{-CCPCH_Ec/I_{or}} = -12 \text{ dB}$
P-CCPCH (antenna 2)	$P\text{-CCPCH_Ec2/I_{or}} = -15 \text{ dB}$	
SCH (antenna 1 / 2)	$SCH_Ec/I_{or} = -12 \text{ dB}$	1. TSTD applied. 2. This power shall be divided equally between Primary and Secondary Synchronous channels
PICH (antenna 1)	$PICH_Ec1/I_{or} = -18 \text{ dB}$	1. STTD applied 2. Total $PICH_Ec/I_{or} = -15 \text{ dB}$
PICH (antenna 2)	$PICH_Ec2/I_{or} = -18 \text{ dB}$	
DPCH	Test dependent power	1. STTD applied 2. Total power from both antennas
OCNS	Necessary power so that total transmit power spectral density of Node B (I_{or}) adds to one	1. This power shall be divided equally between antennas 2. OCNS interference consists of 16 dedicated data channels. The channelization codes, level settings and timing offsets for data channels are chosen as specified for the 16 DPCH channels of Test Model 1 in TS 25.141 [10] Table 6.2E.3.6. 3. <u>All dedicated channels user data is uncorrelated to each other and the measurement channel during the BER/BLER measurement period.</u>

Note 1: For dynamic power correction required to compensate for the presence of transient channels, e.g. control channels, a subset of the DPCH channels may be used.

² Power levels are based on the assumption that multipath propagation conditions and noise source representing interference from other cells I_{oc} are turned on after the call set-up phase.

E.3.5 Connection with closed loop transmit diversity mode

Table E.3.5 is applicable for measurements for subclause 7.6.2 (Demodulation of DCH in closed loop transmit diversity mode)

Table E.3.5: Downlink Physical Channels transmitted during a connection³

Physical Channel	Power	Note
P-CPICH (antenna 1)	P-CPICH_Ec1/lor = -13 dB	1. Total P-CPICH_Ec/lor = -10 dB
P-CPICH (antenna 2)	P-CPICH_Ec2/lor = -13 dB	
P-CCPCH (antenna 1)	P-CCPCH_Ec1/lor = -15 dB	1. STTD applied
P-CCPCH (antenna 2)	P-CCPCH_Ec2/lor = -15 dB	1. STTD applied, total P-CCPCH_Ec/lor = -12 dB
SCH (antenna 1 / 2)	SCH_Ec/lor = -12 dB	1. TSTD applied
PICH (antenna 1)	PICH_Ec1/lor = -18 dB	1. STTD applied
PICH (antenna 2)	PICH_Ec2/lor = -18 dB	2. STTD applied, total PICH_Ec/lor = -15 dB
DPCH	Test dependent power	1. Total power from both antennas
OCNS	Necessary power so that total transmit power spectral density of Node B (lor) adds to one	1. This power shall be divided equally between antennas 2. OCNS interference consists of 16 dedicated data channels. The channelization codes, level settings and timing offsets for data channels are chosen as specified for the 16 DPCH channels of Test Model 4 in TS 25.141 [10] Table 6.2E.3.6. 3. All dedicated channels user data is uncorrelated to each other and the measurement channel during the BER/BLER measurement period.

Note 1: For dynamic power correction required to compensate for the presence of transient channels, e.g. control channels, a subset of the DPCH channels may be used.

Table E.3.6: DPCH Spreading Code, Timing offsets and relative level settings for OCNS signal.

Channelization Code	Timing offset (x256T _{chip})	Level setting (dB)
2	86	-1
11	134	-3
17	52	-3
23	45	-5
31	143	-2
38	112	-4
47	59	-8
55	23	-7
62	1	-4
69	88	-6
78	30	-5
85	18	-9
94	30	-10
102	61	-8
113	128	-6
119	143	0

Note: The DPCH Spreading Codes, Timing offsets and relative level settings are chosen for simulating a signal with realistic PAR.

³ Power levels are based on the assumption that multipath propagation conditions and noise source representing interference from other cells Ioc are turned on after the call set-up phase.

CHANGE REQUEST

⌘ **TS 34.121 CR 091** ⌘ rev ⌘ Current version: **3.4.0** ⌘

For **HELP** on using this form, see bottom of this page or look at the pop-up text over the ⌘ symbols.

Proposed change affects: ⌘ (U)SIM ME/UE Radio Access Network Core Network

Title:	⌘ Replacement for the Conformance requirements		
Source:	⌘ T1/RF		
Work item code:	⌘ 	Date:	⌘ 14 May, 2001
Category:	⌘ D	Release:	⌘ R99
	<i>Use <u>one</u> of the following categories:</i> F (essential correction) A (corresponds to a correction in an earlier release) B (Addition of feature), C (Functional modification of feature) D (Editorial modification) Detailed explanations of the above categories can be found in 3GPP TR 21.900.		<i>Use <u>one</u> of the following releases:</i> 2 (GSM Phase 2) R96 (Release 1996) R97 (Release 1997) R98 (Release 1998) R99 (Release 1999) REL-4 (Release 4) REL-5 (Release 5)

Reason for change:	⌘ To keep consistency with the core specification
Summary of change:	⌘ Replace "Conformance requirements" with "Minimum requirements"
Consequences if not approved:	⌘ Inconsistencies with the core specification are caused.

Clauses affected:	⌘ Chapter 5, 6 and 7	
Other specs affected:	⌘ <input type="checkbox"/> Other core specifications <input type="checkbox"/> Test specifications <input type="checkbox"/> O&M Specifications	⌘
Other comments:	⌘ 	

How to create CRs using this form:

Comprehensive information and tips about how to create CRs can be found at: http://www.3gpp.org/3G_Specs/CRs.htm. Below is a brief summary:

- 1) Fill out the above form. The symbols above marked ⌘ contain pop-up help information about the field that they are closest to.
- 2) Obtain the latest version for the release of the specification to which the change is proposed. Use the MS Word "revision marks" feature (also known as "track changes") when making the changes. All 3GPP specifications can be downloaded from the 3GPP server under <ftp://www.3gpp.org/specs/>. For the latest version, look for the directory name with the latest date e.g. 2000-09 contains the specifications resulting from the September 2000 TSG meetings.
- 3) With "track changes" disabled, paste the entire CR form (use CTRL-A to select it) into the specification just in front of the clause containing the first piece of changed text. Delete those parts of the specification which are not relevant to the change request.

5 Transmitter Characteristics

5.4 Output Power Dynamics in the Uplink

5.4.1 Open Loop Power Control in the Uplink

5.4.1.2 ~~Conformance~~Minimum requirements

5.4.2 Inner Loop Power Control in the Uplink

5.4.2.2 ~~Conformance~~Minimum requirements

5.5 Transmit ON/OFF Power

5.5.2 Transmit ON/OFF Time mask

5.5.2.2 ~~Conformance~~Minimum requirements

5.6 Change of TFC

5.6.2 ~~Conformance~~Minimum requirements

5.7 Power setting in uplink compressed mode

5.7.2 ~~Conformance~~Minimum requirements

6 Receiver Characteristics

6.3 Maximum Input Level

6.3.2 ~~Conformance~~Minimum requirements

-
- 7 Performance requirements
 - 7.2 Demodulation in Static Propagation conditions
 - 7.2.1 Demodulation of Dedicated Channel (DCH)
 - 7.2.1.2 ~~Conformance~~Minimum requirements
 - 7.3 Demodulation of DCH in Multi-path Fading Propagation conditions
 - 7.3.1 Single Link Performance
 - 7.3.1.2 ~~Conformance~~Minimum requirements
 - 7.4 Demodulation of DCH in Moving Propagation conditions
 - 7.4.1 Single Link Performance
 - 7.4.1.2 ~~Conformance~~Minimum requirements
 - 7.5 Demodulation of DCH in Birth-Death Propagation conditions
 - 7.5.1 Single Link Performance
 - 7.5.1.2 ~~Conformance~~Minimum requirements
 - 7.6 Demodulation of DCH in Base Station Transmit diversity modes
 - 7.6.1 Demodulation of DCH in open-loop transmit diversity mode
 - 7.6.1.2 ~~Conformance~~Minimum requirements

7.6.2 Demodulation of DCH in closed loop transmit diversity mode

7.6.2.2 ConformanceMinimum requirements

7.6.3 Demodulation of DCH in Site Selection Diversity Transmission Power Control mode

7.6.3.2 ConformanceMinimum requirements

7.7 Demodulation in Handover conditions

7.7.1 Demodulation of DCH in Inter-Cell Soft Handover

7.7.1.2 ConformanceMinimum requirements

7.7.2 Combining of TPC commands from radio links of different radio link sets

7.7.2.2 ConformanceMinimum requirements

7.8 Power control in downlink

7.8.1 Power control in the downlink, constant BLER target

7.8.1.2 ConformanceMinimum requirements

7.8.2 Power control in the downlink, initial convergence

7.8.2.2 ConformanceMinimum requirements

7.8.3 Power control in the downlink, wind up effects

7.8.3.2 ConformanceMinimum requirements

7.9 Downlink compressed mode

7.9.1 Single link performance

7.9.1.2 ~~Conformance~~Minimum requirements

7.10 Blind transport format detection

7.10.2 ~~Conformance~~Minimum requirements

CHANGE REQUEST

⌘ **34.121** **CR 092** ⌘ rev **-** ⌘ Current version: **3.4.0** ⌘

For **HELP** on using this form, see bottom of this page or look at the pop-up text over the ⌘ symbols.

Proposed change affects: ⌘ (U)SIM ME/UE Radio Access Network Core Network

Title:	⌘ Test conditions for TS 34.121		
Source:	⌘ T1/RF		
Work item code:	⌘	Date:	⌘ 2001-5-14
Category:	⌘ F	Release:	⌘ R99
	<i>Use one of the following categories:</i> F (essential correction) A (corresponds to a correction in an earlier release) B (Addition of feature), C (Functional modification of feature) D (Editorial modification) Detailed explanations of the above categories can be found in 3GPP TR 21.900.		<i>Use one of the following releases:</i> 2 (GSM Phase 2) R96 (Release 1996) R97 (Release 1997) R98 (Release 1998) R99 (Release 1999) REL-4 (Release 4) REL-5 (Release 5)

Reason for change:	⌘ Environmental test conditions and used test frequencies are not specified for each test case. European regulatory document states that TS 34.121 defines exceptions for normal test conditions
Summary of change:	⌘ Test conditions are defined for each test case in subclauses 5, 6 and 7
Consequences if not approved:	⌘ Inconsistency between TS 34.121 and European regulatory requirements

Clauses affected:	⌘ 5, 6, 7		
Other specs Affected:	<input type="checkbox"/> Other core specifications ⌘ <input type="checkbox"/> Test specifications ⌘ <input type="checkbox"/> O&M Specifications ⌘		
Other comments:	⌘		

How to create CRs using this form:

Comprehensive information and tips about how to create CRs can be found at: http://www.3gpp.org/3G_Specs/CRs.htm. Below is a brief summary:

- 1) Fill out the above form. The symbols above marked ⌘ contain pop-up help information about the field that they are closest to.
- 2) Obtain the latest version for the release of the specification to which the change is proposed. Use the MS Word "revision marks" feature (also known as "track changes") when making the changes. All 3GPP specifications can be downloaded from the 3GPP server under <ftp://www.3gpp.org/specs/>. For the latest version, look for the directory name with the latest date e.g. 2000-09 contains the specifications resulting from the September 2000 TSG meetings.
- 3) With "track changes" disabled, paste the entire CR form (use CTRL-A to select it) into the specification just in front of the clause containing the first piece of changed text. Delete those parts of the specification which are not relevant to the change request.

5 Transmitter Characteristics

5.1 General

Transmitting performance test of the UE is implemented during communicating with the SS via air interface. The procedure is using normal call protocol until the UE is communicating on traffic channel basically. On the traffic channel, the UE provides special function for testing that is called Logical Test Interface and the UE is tested using this function. (Refer to [4] TS 34.109).

Transmitting or receiving bit/symbol rate for test channel is shown in Table 5.1.

Table 5.1: Bit / Symbol rate for Test Channel

Type of User Information	User bit rate	DL DPCH symbol rate	UL DPCH bit rate	Remarks
12.2 kbps reference measurement channel	12.2 kbps	30 ksps	60 kbps	Standard Test

Unless detailed the transmitter characteristic are specified at the antenna connector of the UE. For UE with integral antenna only, a reference antenna with a gain of 0 dBi is assumed. Transmitter characteristics for UE(s) with multiple antennas/antenna connectors are FFS.

The UE antenna performance has a significant impact on system performance, and minimum requirements on the antenna efficiency are therefore intended to be included in future versions of this specification. It is recognised that different requirements and test methods are likely to be required for the different types of UE.

All the parameters in clause 5 are defined using the UL reference measurement channel (12.2 kbps) specified in subclause C.2.1 and unless stated otherwise, with the UL power control ON.

The common RF test conditions of Tx Characteristics are defined in Annex E.3.1, and each test conditions in this clause (clause 5) should refer Annex E.3.1. Individual test conditions are defined in the paragraph of each test.

5.2 Maximum Output Power

5.2.1 Definition and applicability

The maximum output power and its tolerance are defined according to the Power Class of the UE.

The maximum output power refers to the measure power when averaged over the transmit slot at the maximum power control setting.

The requirements and this test apply to all types of UTRA for the FDD UE.

5.2.2 Minimum Requirements

The UE maximum output power shall be within the shown value in Table 5.2.1 even for the multi-code transmission mode.

Table 5.2.1: Maximum Output Power

Power Class	Maximum output power	Tolerance
1	+33 dBm	+1/-3 dB
2	+27 dBm	+1/-3 dB
3	+24 dBm	+1/-3 dB
4	+21 dBm	± 2 dB

The normative reference for this requirement is [1] TS 25.101 subclause 6.2.1.

5.2.3 Test purpose

To verify that the error of the UE maximum output power does not exceed the prescribed tolerance in Table 5.2.1.

An excess maximum output power has the possibility to interfere to other channels or other systems. A small maximum output power decreases the coverage area.

5.2.4 Method of test

5.2.4.1 ~~5.2.4.1~~ Initial conditions

Test environment: normal, TL/VL, TL/VH, TH/VL, TH/VH; see subclauses G.2.1 and G.2.2.

Frequencies to be tested: low range, mid range, high range; see subclause G.2.4.

- 1) Connect the SS to the UE antenna connector as shown in Figure A.1.
- 2) A call is set up according to the Generic call setup procedure.
- 3) Enter the UE into loopback test mode and start the loopback test.

See [3] TS 34.108 and [4] TS 34.109 for details regarding generic call setup procedure and loopback test.

5.2.4.2 Procedure

- 1) Set and send continuously Up power control commands to the UE.
- 2) Measure the output power of the UE by Tester. The output power shall be averaged over the transmit one timeslot.

5.2.5 Test requirements

The error of measured output power, derived in step 2), shall not exceed the prescribed tolerance in Table 5.2.2.

Table 5.2.2: Maximum Output Power

Power Class	Maximum output power	Tolerance
1	+33 dBm	+1.7/-3.7 dB
2	+27 dBm	+1.7/-3.7 dB
3	+24 dBm	+1.7/-3.7 dB
4	+21 dBm	± 2.7 dB

NOTE: If the above Test Requirement differs from the Minimum Requirement then the Test Tolerance applied for this test is non-zero. The Test Tolerance for this test is defined in Annex F.2 and the explanation of how the Minimum Requirement has been relaxed by the Test Tolerance is given in Annex F.4.

5.3 Frequency Error

5.3.1 Definition and applicability

The frequency error is the difference between the RF modulated carrier frequency transmitted from the UE with AFC ON and assigned frequency. The UE transmitter tracks to the RF carrier frequency received from the Node B. These signals will have an apparent error due to Node B frequency error and Doppler shift. In the later case, signals from the Node B must be averaged over sufficient time that errors due to noise or interference are allowed for within the above ± 0.1 PPM figure.

The UE shall use the same frequency source for both RF frequency generation and the chip clock.

The requirements and this test apply to all types of UTRA for the FDD UE.

5.3.2 Minimum Requirements

The UE modulated carrier frequency shall be accurate to within ± 0.1 ppm compared to the carrier frequency received from the Node B.

The normative reference for this requirement is [1] TS 25.101 subclause 6.3.

5.3.3 Test purpose

To verify that the UE carrier frequency error does not exceed ± 0.1 ppm.

An excess error of the carrier frequency increases the transmission errors in the up link own channel.

This test verifies the ability of receiver to derive correct frequency information for transmitter.

5.3.4 Method of test

5.3.4.1 ~~5.3.4.1~~ Initial conditions

Test environment: normal, TL/VL, TL/VH, TH/VL, TH/VH, vibration; see subclauses G.2.1, G.2.2 and G.2.3.

Frequencies to be tested: low range, mid range, high range; see subclause G.2.4.

- 1) Connect the SS to the UE antenna connector as shown in Figure A.1.
- 2) A call is set up according to the Generic call setup procedure, and RF parameters (DPCH_Ec and \hat{I}_{or}) are set up according to Table 5.3. The relative power level of other downlink physical channels to the DPCH_Ec are set up according to Annex E.3.1.
- 3) Enter the UE into loopback test mode and start the loopback test.

See [3] TS 34.108 and [4] TS 34.109 for details regarding generic call setup procedure and loopback test.

Table 5.3: Test parameters for Frequency Error

Parameter	Level / Status	Unit
DPCH_Ec	-117	dBm / 3.84 MHz
\hat{I}_{or}	-106.7	dBm / 3.84 MHz

5.3.4.2 Procedure

- 1) Set and send continuously Up power control commands to the UE until the UE output power shall be maximum level.
- 2) Measure the frequency error delta f, at the UE antenna connector by Tester using Global In-Channel-Tx-test (Annex B). Since counter method leads an incorrect result, EVM method shall be used.

5.3.5 Test Requirements

For all measured bursts, the frequency error, derived in step 2), shall not exceed $\pm(0.1 \text{ ppm} + 10 \text{ Hz})$.

NOTE: If the above Test Requirement differs from the Minimum Requirement then the Test Tolerance applied for this test is non-zero. The Test Tolerance for this test is defined in Annex F.2 and the explanation of how the Minimum Requirement has been relaxed by the Test Tolerance is given in Annex F.4.

5.4 Output Power Dynamics in the Uplink

Power control is used to limit the interference level.

5.4.1 Open Loop Power Control in the Uplink

5.4.1.1 Definition and applicability

Open loop power control in the uplink is the ability of the UE transmitter to set its output power to a specific value. This function is used for PRACH transmission and based on the information from Node B using BCCH and the downlink received signal power level of the CPICH. The information from Node B includes transmission power of CPICH and uplink interference power level.

The requirements and this test apply to all types of UTRA for the FDD UE.

5.4.1.2 Conformance requirements

The UE open loop power is defined as the average power in a timeslot or ON power duration, whichever is available, and they are measured with a filter that has a Root-Raised Cosine (RRC) filter response with a roll off $\alpha = 0.22$ and a bandwidth equal to the chip rate.

The UE open loop power control tolerance is given in Table 5.4.1.1.

Table 5.4.1.1: Open loop power control tolerance

Normal conditions	$\pm 9 \text{ dB}$
Extreme conditions	$\pm 12 \text{ dB}$

The reference for this requirement is [1] TS 25.101 subclause 6.4.1.

5.4.1.3 Test purpose

The power of the received signal and the BCCH information control the power of the transmitted signal with the target to transmit at lowest power acceptable for proper communication.

The test stresses the ability of the receiver to measure the received power correctly over the receiver dynamic range.

The test purpose is to verify that the UE open loop power control tolerance does not exceed the described value shown in Table 5.4.1.1.

An excess error of the open loop power control decreases the system capacity.

5.4.1.4 Method of test

5.4.1.4.1 ~~5.4.1.4.1~~ Initial conditions

Test environment: normal, TL/VL, TL/VH, TH/VL, TH/VH; see subclauses G.2.1 and G.2.2.

Frequencies to be tested: low range, mid range, high range; see subclause G.2.4.

- 1) Connect the SS to the UE antenna connector as shown in Figure A.1.
- 2) A call is set up according to the Generic call setup procedure, and \hat{I}_{or} is set up according to Table 5.4.1.2. The relative power level of downlink physical channels to I_{or} are set up according to Annex E.2.1. The RACH procedure within the call setup is used for the test.

See [3] TS 34.108 for details regarding generic call setup procedure.

Table 5.4.1.2: Test parameters for Open Loop Power Control (UE)

Parameter	Level / Status	Unit
\hat{I}_{or}	See Table 5.4.1.3	dBm / 3.84 MHz

Table 5.4.1.3: Test parameters for Open Loop Power Control (SS)

Parameter	RX Upper dynamic end	RX-middle	RX-Sensitivity level
\hat{I}_{or} ³⁾	-25.0 dBm / 3.84 MHz	-65.7 dBm / 3.84 MHz	-106.7 dBm / 3.84 MHz
CPICH_RSCP ^{3),4)}	-28.3 dBm	-69 dBm	-110 dBm
Primary CPICH DL TX power	+19 dBm	+28 dBm	+19 dBm
Simulated path loss = Primary CPICH DL TX power – CPICH_RSCP	+47.3 dBm	+97 dB	+129 dB
UL interference	-75 dBm	-101 dBm	-110 dBm
Constant Value	-10 dB	-10 dB	-10 dB
Expected nominal UE TX power ⁵⁾	-37.7dBm	-14dBm	+9 dBm ²⁾

NOTE 1: While the SS transmit power shall cover the receiver input dynamic range, the logical parameters: Primary CPICH DL TX power, UL interference, Constant Value are chosen to achieve a UE TX power, located within the TX output power dynamic range of a class 4 UE.

NOTE 2: Nominal TX output power 9 dBm allows to check the open loop power algorithm within the entire tolerance range (9 dBm \pm 12 dB; 9 dBm + 12 dB = 21 dBm = max power class 4).

NOTE 3: The power level of S-CCPCH should be defined because S-CCPCH is transmitted during Preamble RACH transmission period. The power level of S-CCPCH is temporarily set to -10.3dB relative to I_{or} . However, it is necessary to check whether the above S-CCPCH level is enough to establish a connection with the reference measurement channels.

NOTE 4: The purpose of this parameter is to calculate the Expected nominal UE TX power.

NOTE 5: The Expected nominal UE TX power is calculated by using the equation in the clause 8.5.9 Open Loop Power Control of [8]TS25.331.

5.4.1.4.2 Procedure

- 1) Set the TX output level of the SS to obtain \hat{I}_{or} at the UE antenna connector. \hat{I}_{or} shall be according to Table 5.4.1.3 (-25 dBm / 3.84 MHz).
- 2) Measure the first RACH preamble output power of the UE according to Annex B.
- 3) Repeat the above measurement for all SS levels in Table 5.4.1.3.

5.4.1.5 Test requirements

The deviation with respect to the Expected nominal UE TX power (Table 5.4.1.3), derived in step 2), shall not exceed the prescribed tolerance in Table 5.4.1.1.

5.4.2 Inner Loop Power Control in the Uplink

5.4.2.1 Definition and applicability

Inner loop power control in the uplink is the ability of the UE transmitter to adjust its output power in accordance with one or more TPC commands received in the downlink.

The power control step is the change in the UE transmitter output power in response to a single TPC command, TPC_cmd, derived at the UE.

This clause does not cover all the requirements of compressed mode or soft handover.

The requirements and this test apply to all types of UTRA for the FDD UE.

5.4.2.2 Conformance requirements

The UE transmitter shall have the capability of changing the output power with a step size of 1, 2 and 3 dB according to the value of Δ_{TPC} or $\Delta_{\text{RP-TPC}}$, in the slot immediately after the TPC_cmd can be derived.

- a) The transmitter output power step due to inner loop power control shall be within the range shown in Table 5.4.2.1. The Maximum power threshold is defined as the lowest permissible maximum output power for the UE power class, as defined in Table 5.2.1. The Minimum power threshold is defined as -50 dBm.
- b) When the transmitter output power is between the Minimum and Maximum power thresholds, the transmitter average output power step due to inner loop power control shall be within the range shown in Table 5.4.2.2. Here a TPC_cmd group is a set of TPC_cmd values derived from a corresponding sequence of TPC commands of the same duration.

NOTE: 3dB inner loop power control steps are only used in compressed mode.

The inner loop power step is defined as the relative power difference between the average power of the original (reference) timeslot and the average power of the target timeslot, not including the transient duration. The transient duration is from $25\mu\text{s}$ before the slot boundary to $25\mu\text{s}$ after the slot boundary. The power is measured with a filter that has a Root-Raised Cosine (RRC) filter response with a roll off $\alpha = 0.22$ and a bandwidth equal to the chip rate.

Table 5.4.2.1: Transmitter power control tolerance

TPC_cmd	Transmitter power control range (all units are in dB)					
	1 dB step size		2 dB step size		3 dB step size	
	Lower	Upper	Lower	Upper	Lower	Upper
+ 1	+0.5	+1.5	+1	+3	+1.5	+4.5
0	-0.5	+0.5	-0.5	+0.5	-0.5	+0.5
- 1	-0.5	-1.5	-1	-3	-1.5	-4.5
+ 1 at or above max power threshold	-0.5	+1.5	-0.5	+3	-0.5	+4.5
- 1 at or below min power threshold	+0.5	-1.5	+0.5	-3	+0.5	-4.5

NOTE: The requirements for TPC_cmd = +1 at or above max power threshold and for TPC_cmd = -1 at or below min power threshold are included to avoid ambiguity in the required test behaviour. These requirements are not explicitly included in [1] but are consistent with [1] and [5].

Table 5.4.2.2: Transmitter average power control tolerance

TPC_cmd group	Transmitter power control range after 10 equal TPC_cmd group (all units are in dB)				Transmitter power control range after 7 equal TPC_cmd groups (all units are in dB)	
	1 dB step size		2 dB step size		3 dB step size	
	Lower	Upper	Lower	Upper	Lower	Upper
+ 1	+8	+12	+16	+24	+16	+26
0	-1	+1	-1	+1	-1	+1
- 1	-8	-12	-16	-24	-16	-26
0,0,0,0,+1	+6	+14	N/A	N/A	N/A	N/A
0,0,0,0,-1	-6	-14	N/A	N/A	N/A	N/A

The reference for this requirement is [1] TS 25.101 subclause 6.4.2.1.1.

The requirements for the derivation of TPC_cmd are detailed in TS 25.214 subclauses 5.1.2.2.2 and 5.1.2.2.3.

5.4.2.3 Test purpose

- To verify that the UE inner loop power control size and response is meet to the described value shown in subclause 5.4.2.2.
- To verify that TPC_cmd is correctly derived from received TPC commands.

An excess error of the inner loop power control decreases the system capacity.

5.4.2.4 Method of test

5.4.2.4.1 ~~5.4.2.4.1~~ Initial conditions

Test environment: normal; see subclauses G.2.1 and G.2.2.

Frequencies to be tested: mid range; see subclause G.2.4.

- 1) Connect the SS to the UE antenna connector as shown in Figure A.1.
- 2) A call is set up according to the Generic call setup procedure. The Uplink DPCH Power Control Info shall specify the Power Control Algorithm as algorithm 2 for interpreting TPC commands.
- 3) Enter the UE into loopback test mode and start the loopback test.

See [3] TS 34.108 and [4] TS 34.109 for details regarding generic call setup procedure and loopback test.

5.4.2.4.2

Procedure

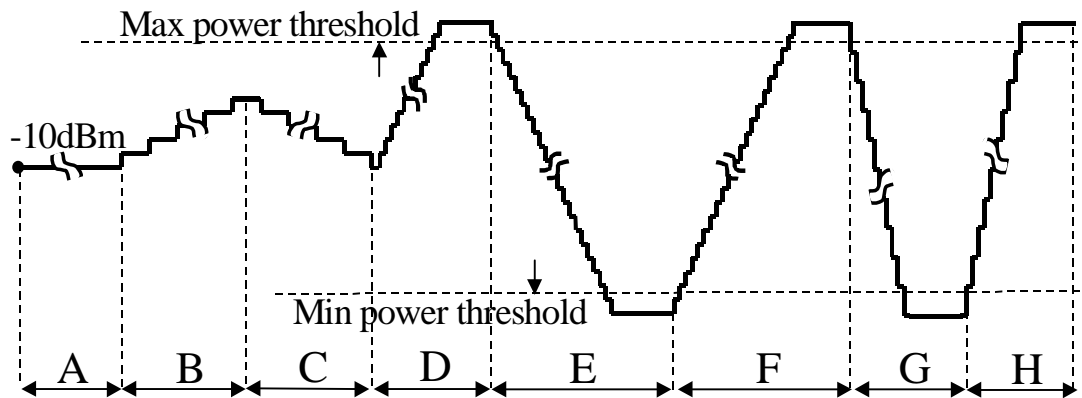

Figure 5.4.2.4 Inner Loop Power Control Test Steps

- 1) Before proceeding with paragraph (2) (Step A) below, set the output power of the UE, measured at the UE antenna connector, to be in the range -10 ± 9 dBm. This may be achieved by setting the downlink signal (\hat{I}_{or}) to yield an appropriate open loop output power and/or by generating suitable downlink TPC commands from the SS.
- 2) Step A: Transmit a sequence of at least 30 and no more than 60 TPC commands, which shall commence at a frame boundary and last for a whole number of frames, and which shall contain:
 - no sets of 5 consecutive "0" or "1" commands which commence in the 1st, 6th or 11th slots of a frame;
 - at least one set of 5 consecutive "0" commands which does not commence in the 1st, 6th or 11th slots of a frame;
 - at least one set of 5 consecutive "1" commands which does not commence in the 1st, 6th or 11th slots of a frame.

The following is an example of a suitable sequence of TPC commands:

```
10000010101010111110100000101010101111010000010101010111110
```

- 3) Step B: Transmit a sequence of 50 TPC commands with the value 1.
- 4) Step C: Transmit a sequence of 50 TPC commands with the value 0.
- 5) Step D: Reconfigure the uplink channel to set the Power Control Algorithm to algorithm 1, and the TPC step size to 1 dB. When the reconfiguration is complete, transmit a sequence of TPC commands with the value 1 until the UE output power is above the maximum power threshold.
- 6) Step E: Transmit a sequence of 150¹ TPC commands with the value 0.
- 7) Step F: Transmit a sequence of 150¹ TPC commands with the value 1.

- 8) Step G: Reconfigure the uplink channel to set the TPC step size to 2 dB (with the Power Control Algorithm remaining as algorithm 1). When the reconfiguration is complete, transmit a sequence of TPC commands with the value 1 until the UE output power is above the maximum power threshold. Transmit a sequence of 75¹ TPC commands with the value 0.
- 9) Step H: Transmit a sequence of 75¹ TPC commands with the value 1.
- 10) During steps A to H the mean output power of every slot shall be measured, with the following exceptions:
- In steps D and F, measurement of the output power is not required in slots after the 10th slot after the mean output power has exceeded the maximum power threshold;
 - In steps E and G, measurement of the output power is not required in slots after the 10th slot after the mean output power has fallen below the minimum power threshold.

The transient periods of 25µs before each slot boundary and 25µs after each slot boundary shall not be included in the power measurements.

¹ NOTE: These numbers of TPC commands are given as examples. The actual number of TPC commands transmitted in these steps shall be at least 10 more than the number required to ensure that the UE reaches the relevant maximum or minimum power threshold in each step, as shown in Figure 5.4.2.4.

5.4.2.5 Test requirements

- a) During Step A, the difference in mean output power between adjacent slots shall be within the prescribed range for a TPC_cmd of 0, as given in Table 5.4.2.1.
- b) During Step A, the change in mean output power over 10 consecutive slots shall be within the prescribed range for a TPC_cmd group of 0, as given in Table 5.4.2.2.
- c) During Step B, the difference in mean output power between adjacent slots shall be within the prescribed range given in Table 5.4.2.1, given that every 5th TPC_cmd should have the value + 1, with a step size of 1 dB, and all other TPC_cmd should have the value 0.
- d) During Step B, the change in mean output power over 50 consecutive slots shall be within the prescribed range for a TPC_cmd group of {0,0,0,0,+1}, as given in Table 5.4.2.2.
- e) During Step C, the difference in mean output power between adjacent slots shall be within the prescribed range given in Table 5.4.2.1, given that every 5th TPC_cmd should have the value – 1, with a step size of 1 dB, and all other TPC_cmd should have the value 0.
- f) During Step C, the change in mean output power over 50 consecutive slots shall be within the prescribed range for a TPC_cmd group of {0,0,0,0,-1}, as given in Table 5.4.2.2.
- g) During Step E, the difference in mean output power between adjacent slots shall be within the prescribed range given in Table 5.4.2.1 for a TPC_cmd of – 1 and step size of 1 dB, until the output power reaches (Minimum power threshold + 0.5 dB). When the output power is between the values of (Minimum power threshold + 0.5 dB) and (Minimum power threshold), the difference in mean output power between adjacent slots shall be at least sufficient to decrease the output power to the Minimum power threshold, but shall not exceed – 1.5 dB. Once the output power is at or below the Minimum power threshold, the relevant condition in Table 5.4.2.1 shall be met.
- h) During Step E, the change in mean output power over 10 consecutive slots shall be within the prescribed range for a TPC_cmd group of – 1, and step size of 1 dB as given in Table 5.4.2.2, until the output power reaches (Minimum power threshold + 0,5 dB).

- i) During Step F, the difference in mean output power between adjacent slots shall be within the prescribed range given in Table 5.4.2.1 for a TPC_cmd of + 1 and step size of 1 dB, until the output power reaches (Maximum power threshold – 0,5 dB). When the output power is between the values of (Maximum power threshold – 0,5 dB) and (Maximum power threshold), the difference in mean output power between adjacent slots shall be at least sufficient to increase the output power to the Maximum power threshold, but shall not exceed + 1,5 dB. Once the output power is at or above the Maximum power threshold, the relevant condition in Table 5.4.2.1 shall be met.
- j) During Step F, the change in mean output power over 10 consecutive slots shall be within the prescribed range for a TPC_cmd group of + 1, and step size of 1 dB as given in Table 5.4.2.2, until the output power reaches (Maximum power threshold – 0,5 dB).
- k) During Step G, the difference in mean output power between adjacent slots shall be within the prescribed range given in Table 5.4.2.1 for a TPC_cmd of – 1 and step size of 2 dB, until the output power reaches (Minimum power threshold + 1 dB). When the output power is between the values of (Minimum power threshold + 1 dB) and (Minimum power threshold), the difference in mean output power between adjacent slots shall be at least sufficient to decrease the output power to the Minimum power threshold, but shall not exceed – 3 dB. Once the output power is at or below the Minimum power threshold, the relevant condition in Table 5.4.2.1 shall be met.
- l) During Step G, the change in mean output power over 10 consecutive slots shall be within the prescribed range for a TPC_cmd group of – 1, and step size of 2 dB as given in Table 5.4.2.2, until the output power reaches (Minimum power threshold +1 dB).
- m) During Step H, the difference in mean output power between adjacent slots shall be within the prescribed range given in Table 5.4.2.1 for a TPC_cmd of + 1 and step size of 2 dB, until the output power reaches (Maximum power threshold –1 dB). When the output power is between the values of (Maximum power threshold –1 dB) and (Maximum power threshold), the difference in mean output power between adjacent slots shall be at least sufficient to increase the output power to the Maximum power threshold, but shall not exceed + 3 dB. Once the output power is at or above the Maximum power threshold, the relevant condition in Table 5.4.2.1 shall be met.
- n) During Step H, the change in mean output power over 10 consecutive slots shall be within the prescribed range for a TPC_cmd group of + 1, and step size of 2 dB as given in Table 5.4.2.2, until the output power reaches (Maximum power threshold – 1 dB).

5.4.3 Minimum Output Power

5.4.3.1 Definition and applicability

The minimum controlled output power of the UE is when the power control setting is set to a minimum value. This is when both the inner loop and open loop power control indicate a minimum transmit output power is required.

The requirements and this test apply to all types of UTRA for the FDD UE.

5.4.3.2 Minimum Requirements

The minimum transmit power is defined as an averaged power in a time slot measured with a filter that has a Root-Raised Cosine (RRC) filter response with a roll off $\alpha = 0.22$ and a bandwidth equal to the chip rate. The minimum transmit power shall be better than –50 dBm.

The normative reference for this requirement is [1] TS 25.101 subclause 6.4.3.1.

5.4.3.3 Test purpose

To verify that the UE minimum transmit power is below –50 dBm.

An excess minimum output power increases the interference to other channels, and decreases the system capacity.

5.4.3.4 Method of test

5.4.3.4.1 ~~5.4.3.4.1~~ Initial conditions

Test environment: normal, TL/VL, TL/VH, TH/VL, TH/VH; see subclauses G.2.1 and G.2.2.

Frequencies to be tested: low range, mid range, high range; see subclause G.2.4.

- 1) Connect the SS to the UE antenna connector as shown in Figure A.1.
- 2) A call is set up according to the Generic call setup procedure.
- 3) Enter the UE into loopback test mode and start the loopback test.

See [3] TS 34.108 and [4] TS 34.109 for details regarding generic call setup procedure and loopback test.

5.4.3.4.2 Procedure

- 1) Set and send continuously Down power control commands to the UE.
- 2) Measure the output power of the UE by Tester.

5.4.3.5 Test requirements

The measured output power, derived in step 2), shall be below -49 dBm.

NOTE: If the above Test Requirement differs from the Minimum Requirement then the Test Tolerance applied for this test is non-zero. The Test Tolerance for this test is defined in Annex F.2 and the explanation of how the Minimum Requirement has been relaxed by the Test Tolerance is given in Annex F.4.

5.4.4 Out-of-synchronisation handling of output power

5.4.4.1 Definition and applicability

The UE shall monitor the DPCCCH quality in order to detect a loss of the signal on Layer 1, as specified in [5] TS 25.214. The thresholds Q_{out} and Q_{in} specify at what DPCCCH quality levels the UE shall shut its power off and when it shall turn its power on respectively. The thresholds are not defined explicitly, but are defined by the conditions under which the UE shall shut its transmitter off and turn it on, as stated in this subclause.

5.4.4.2 Minimum Requirements

The parameters in Table 5.4.4.1 are defined using the DL reference measurement channel (12.2 kbps) specified in Annex C.3.1 and with static propagation conditions.

Table 5.4.4.1: DCH parameters for test of Out-of-synch handling

Parameter	Value	Unit
\hat{I}_{or}/I_{oc}	-1	dB
I_{oc}	-60	dBm / 3.84 MHz
$\frac{DPDCH_E_c}{I_{or}}$	See Figure 5.4.4.1: Before point A -16.6 After point A Not defined ¹⁾	dB
$\frac{DPCCCH_E_c}{I_{or}}$	See Table 5.4.4.2	dB
Information Data Rate	12.2	kbps
TFCI	on	-

Table 5.4.4.2: Minimum Requirements for DPCCH_Ec/I_{or} levels

Section from figure 5.4.4.1	DPCCH_Ec/I _{or}	Unit
Before A	-16.6	dB
A to B	-22.0	dB
B to D	-28.0	dB
D to E	-24.0	dB
After E	-18.0	dB

The conditions for when the UE shall shut its transmitter off and when it shall turn it on are defined by the parameters in Table 5.4.4.1 and Table 5.4.4.2.

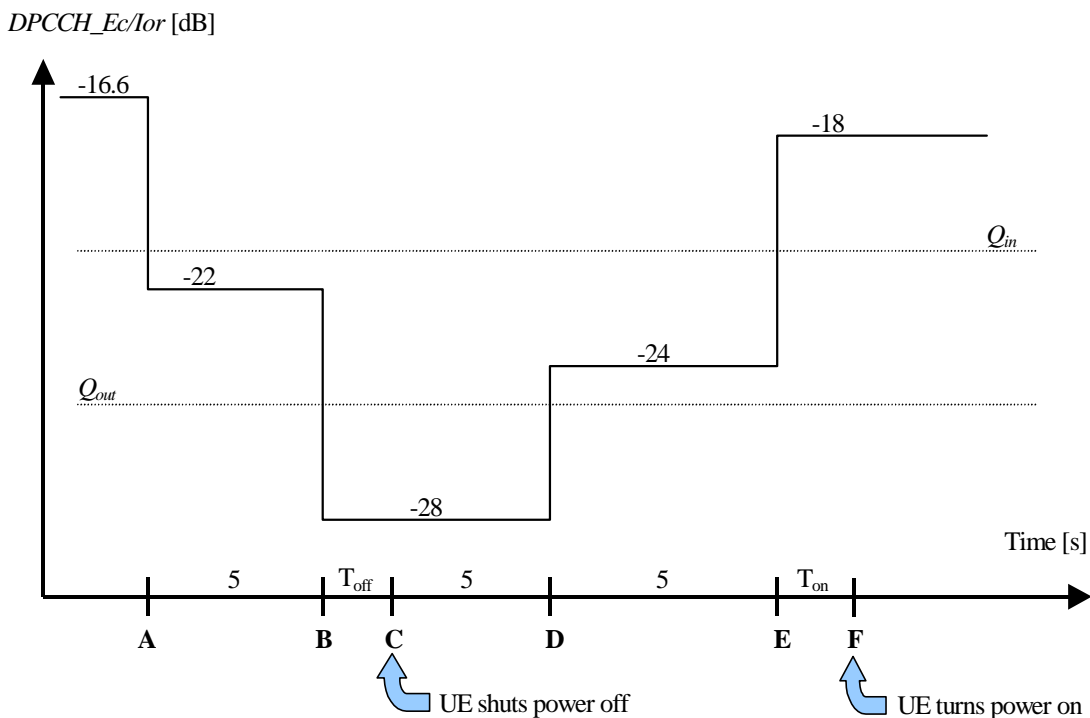

Figure 5.4.4.1: Conditions for out-of-synch handling in the UE. The indicated thresholds Q_{out} and Q_{in} are only informative.

The requirements for the UE are that

1. The UE shall not shut its transmitter off before point B.
2. The UE shall shut its transmitter off before point C, which is T_{off} = 200 ms after point B.
3. The UE shall not turn its transmitter on between points C and E.
4. The UE shall turn its transmitter on before point F, which is T_{on}=200ms after point E.

The normative reference for this requirement is [1] TS 25.101 subclause 6.4.4.1.

5.4.4.3 Test purpose

To verify that the UE monitors the DPCCH quality and turns its transmitter on or off according to DPCCH level diagram specified in Figure 5.4.4.1.

NOTE 1: DPCCH_Ec/I_{or} after point A is not defined in Table 5.4.4.1. However it is assumed that DPCCH and DPCCH power level are same on DL 12.2kbps reference measurement channel for testing. (PO1, PO2, and PO3 are zero.)

5.4.4.4 Method of test

5.4.4.4.1 ~~5.4.4.4.1~~ Initial conditions

Test environment: normal; see subclauses G.2.1 and G.2.2.

Frequencies to be tested: mid range; see subclause G.2.4.

- 1) Connect the SS to the UE antenna connector as shown in Figure A.1.
- 2) A call is set up according to the Generic call setup procedure, and DCH parameters are set up according to Table 5.4.4.1 with DPCCH_Ec/Ior ratio level at -16.6 dB. The other RF parameters are set up according to Annex E.3.1.
- 3) Enter the UE into loopback test mode and start the loopback test.

See [3] TS 34.108 and [4] TS 34.109 for details regarding generic call setup procedure and loopback test.

5.4.4.4.2 Procedure

- 1) The SS sends continuously Up power control commands to the UE until the UE transmitter power reach maximum level.
- 2) The SS controls the DPCCH_Ec/Ior ratio level according to section 'A to B' as defined in Table 5.4.4.3. The SS monitors the UE transmitted power for 5 seconds and verifies that the UE transmitter is not switched off during this time.
- 3) The SS controls the DPCCH_Ec/Ior ratio level according to section 'B to D' as defined in Table 5.4.4.3. The SS waits 200 ms and then verifies that the UE transmitter has been switched off.
- 4) The SS monitors the UE transmitted power for 5 seconds and verifies that the UE transmitter is not switched on during this time.
- 5) The SS controls the DPCCH_Ec/Ior ratio level according to section 'E to F' as defined in Table 5.4.4.3. The SS monitors the UE transmitted power for 5 seconds and verifies that the UE transmitter is not switched on during this time.
- 6) The SS controls the DPCCH_Ec/Ior ratio level according to section 'After F' as defined in Table 5.4.4.3. The SS waits 200 ms and then verifies that the UE transmitter has been switched on.

5.4.4.5 Test requirements

Table 5.4.4.3: Test Requirements for DPCCH_Ec/Ior levels

Section from figure 5.4.4.1	DPCCH_Ec/Ior	Unit
Before A	-16.6	dB
A to B	-[21.7]	dB
B to D	-[28.3]	dB
D to E	-[24.3]	dB
After E	-[17.7]	dB

To pass the test, steps 1 through 6 of the procedure in 5.4.4.4.2 must be fulfilled.

The UE transmitter off criterion and its tolerances is defined in subclause 5.5.1 (Transmit off power)

The UE transmitter on criterion and its tolerances is defined in subclause 5.4.3 (Minimum Output Power). The UE transmitter is considered to be on if the UE transmitted power is higher than minimum output power.

NOTE: If the above Test Requirement differs from the Minimum Requirement then the Test Tolerance applied for this test is non-zero. The Test Tolerance for this test is defined in Annex F.2 and the explanation of how the Test Requirement has been relaxed by the Test Tolerance is given in Annex F.4.

5.5 Transmit ON/OFF Power

5.5.1 Transmit OFF Power

5.5.1.1 Definition and applicability

The transmit OFF power state is when the UE does not transmit except during uplink compressed mode. This parameter is defined as the maximum output transmit power within the channel bandwidth when the transmitter is OFF.

The requirements and this test apply to all types of UTRA for the FDD UE.

5.5.1.2 Minimum Requirements

The transmit OFF power is defined as an averaged power at least in a timeslot duration, excluding any transient periods, measured with a filter that has a Root-Raised Cosine (RRC) filter response with a roll off $\alpha = 0.22$ and a bandwidth equal to the chip rate. The requirement for the transmit OFF power shall be better than -56 dBm.

The normative reference for this requirement is [1] TS 25.101 subclause 6.5.1.1.

5.5.1.3 Test purpose

To verify that the UE transmit OFF power is below -56 dBm.

An excess transmit OFF power increases the interference to other channels, and decreases the system capacity.

5.5.1.4 Method of test

This test is also covered by subclause 5.5.2 Transmit ON/OFF Time mask.

5.5.1.4.1 ~~5.5.1.4.1~~ Initial conditions

Test environment: normal, TL/VL, TL/VH, TH/VL, TH/VH; see subclauses G.2.1 and G.2.2.

Frequencies to be tested: low range, mid range, high range; see subclause G.2.4.

- 1) Connect the SS to the UE antenna connector as shown in Figure A.1.
- 2) A call is set up according to the Generic call setup procedure.
- 3) Enter the UE into loopback test mode and start the loopback test.

See [3] TS 34.108 and [4] TS 34.109 for details regarding generic call setup procedure and loopback test.

5.5.1.4.2 Procedure

- 1) Send release message to the UE to stop transmitting.
- 2) Measure the leakage power within the transmission band from the UE by the Tester.

5.5.1.5 Test requirements

The measured leakage power, derived in step 2), shall be below -55 dBm.

NOTE: If the above Test Requirement differs from the Minimum Requirement then the Test Tolerance applied for this test is non-zero. The Test Tolerance for this test is defined in Annex F.2 and the explanation of how the Minimum Requirement has been relaxed by the Test Tolerance is given in Annex F.4.

5.5.2 Transmit ON/OFF Time mask

5.5.2.1 Definition and applicability

The time mask for transmit ON/OFF defines the ramping time allowed for the UE between transmit OFF power and transmit ON power. Possible ON/OFF scenarios are PRACH, CPCH or uplink compressed mode.

The requirements and this test apply to all types of UTRA for the FDD UE.

5.5.2.2 Conformance requirements

The transmit power levels versus time shall meet the mask specified in Figure 5.5.1 for PRACH preambles, and the mask in Figure 5.5.2 for all other cases. The signal is measured with a filter that has a Root-Raised Cosine (RRC) filter response with a roll off $\alpha = 0.22$ and a bandwidth equal to the chip rate.

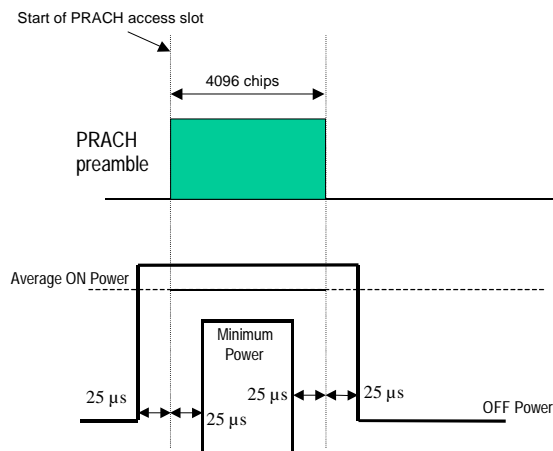

Figure 5.5.1: Transmit ON/OFF template for PRACH preambles

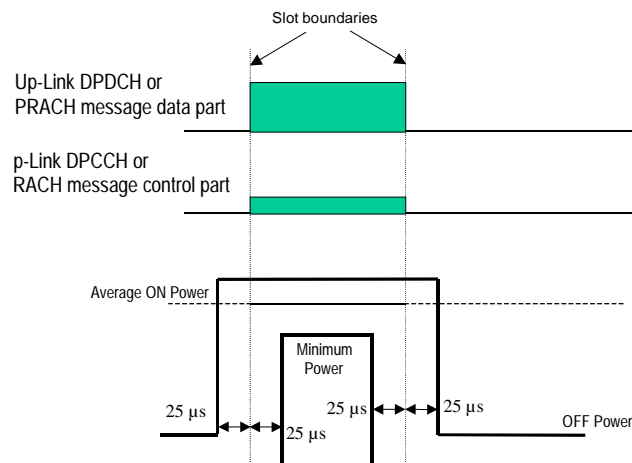

Figure 5.5.2: Transmit ON/OFF template for all other On/Off cases

OFF Power is defined in 5.5.1.

ON power is defined as either case as follows. The specification depends on each possible case.

- First preamble of PRACH: Open loop accuracy (Table 5.4.1.1).
- During preamble ramping of the RACH and between final RACH preamble and RACH message part: Accuracy depending on size of the required power difference (Table 5.5.2.1).
- After transmission gaps in compressed mode: Accuracy as in Table 5.7.1.

- Power step to Maximum Power: Maximum power accuracy (Table 5.2.1).

Table 5.5.2.1: Transmitter power difference tolerance for RACH preamble ramping, and between final RACH preamble and RACH message part

Power difference size ΔP [dB]	Transmitter power difference tolerance [dB]
0	+/- 1 dB
1	+/- 1 dB
2	+/- 1.5 dB
3	+/- 2 dB
$4 \leq \Delta P \leq 10$	+/- 2.5 dB
$11 \leq \Delta P \leq 15$	+/- 3.5 dB
$16 \leq \Delta P \leq 20$	+/- 4.5 dB
$21 \leq \Delta P$	+/- 6.5 dB

The reference for this requirement is [1] TS 25.101 subclause 6.5.2.1.

This is tested using PRACH operation.

The minimum requirement for ON power is defined in subclause 5.4.1.2.

The minimum requirement for OFF power is defined in subclause 5.5.1.2.

Note: The main objective for this test case is to check the ramp-up/down power shape. A test case using the first preamble of PRACH is enough to cover the objective.

5.5.2.3 Test purpose

To verify that the UE transmit ON/OFF power levels versus time meets the described mask shown in Figure 5.5.1 and Figure 5.5.2.

An excess error of transmit ON/OFF response increases the interference to other channels, or increases transmission errors in the up link own channel.

5.5.2.4 Method of test

5.5.2.4.1 ~~5.5.2.4.1~~ Initial conditions

Test environment: normal, TL/VL, TL/VH, TH/VL, TH/VH; see subclauses G.2.1 and G.2.2.

Frequencies to be tested: low range, mid range, high range; see subclause G.2.4.

- 1) Connect the SS to the UE antenna connector as shown in Figure A.1.
- 2) A call is set up according to the Generic call setup procedure, and \hat{I}_{or} are set up according to Table 5.5.2.2. The relative power level of downlink physical channels to I_{or} are set up according to Annex E.2.1.

The RACH procedure within the call setup is used for the test.

See [3] TS 34.108 for details regarding generic call setup procedure.

Table 5.5.2.2: Test parameters for Transmit ON/OFF Time mask (UE)

Parameter	Level / Status	Unit
\hat{I}_{or}	See Table 5.5.2.2	dBm / 3.84 MHz

Table 5.5.2.3: Test parameters for Transmit ON/OFF Time mask (SS)

Parameter	Power Class 1	Power Class 2	Power Class 3	Power Class 4	Unit
\hat{I}_{or} ¹⁾	-106.7	-106.7	-106.7	-106.7	dBm / 3.84 MHz
CPICH_RSCP ^{1),2)}	-110	-110	-110	-110	dBm
Primary CPICH DL TX power	+19	+19	+19	+19	dBm
Simulated path loss = Primary CPICH DL TX power – CPICH_RSCP	+129	+129	+129	+129	dB
UL interference	-86	-92	-95	-98	dBm
Constant Value	-10	-10	-10	-10	dB
Expected nominal UE TX power ³⁾	+33	+27	+24	+21	dBm

NOTE 1: The power level of S-CCPCH should be defined because S-CCPCH is transmitted during Preamble RACH transmission period. The power level of S-CCPCH is temporarily set to -10.3dB relative to \hat{I}_{or} . However, it is necessary to check whether the above S-CCPCH level is enough to establish a connection with the reference measurement channels.

NOTE 2: The purpose of this parameter is to calculate the Expected nominal UE TX power.

NOTE 3: The Expected nominal UE TX power is calculated by using the equation in the clause 8.5.9 Open Loop Power Control of [8] TS25.331.

5.5.2.4.2 Procedure

- 1) Set the TX output level of the SS to obtain \hat{I}_{or} at the UE antenna connector and select the test parameters of Table 5.5.2.3 according to the power class. \hat{I}_{or} shall be according to Table 5.5.2.3 (-106.7 dBm / 3.84 MHz).
- 2) Measure the first RACH preamble output power (ON power) of the UE. The measurements shall not include the transient periods.
- 3) Measure the OFF power immediately before and after the first RACH preamble (ON power). The measurements shall not include the transient periods.

5.5.2.5 Test requirements

The deviation with respect to the Expected nominal UE TX power (Table 5.5.2.3), derived in step 2), shall not exceed the prescribed upper tolerance in Table 5.2.1 (Subclause 5.2.2) and lower tolerance in Table 5.4.1.1. (Subclause 5.4.1.2).

The measured leakage power, derived in step 3), shall be below -56 dBm. (Subclause 5.5.1.2).

5.6 Change of TFC

5.6.1 Definition and applicability

A change of TFC (Transport Format Combination) in uplink means that the power in the uplink varies according to the change in data rate. DTX, where the DPCH is turned off, is a special case of variable data, which is used to minimise the interference between UE(s) by reducing the UE transmit power when voice, user or control information is not present.

The requirements and this test apply to all types of UTRA for the FDD UE.

5.6.2 Conformance requirements

A change of output power is required when the TFC, and thereby the data rate, is changed. The ratio of the amplitude between the DPDCH codes and the DPCCH code will vary. The power step due to a change in TFC shall be calculated in the UE so that the power transmitted on the DPCCH shall follow the inner loop power control. The step in total transmitted power (DPCCH + DPDCH) shall then be rounded to the closest integer dB value. A power step exactly half-way between two integer values shall be rounded to the closest integer of greater magnitude. The accuracy of the power step, given the step size is specified in Table 5.6.1. The power change due to a change in TFC is defined as the relative power difference between the average power of the original (reference) timeslot and the average power of the target timeslot, not including the transient duration. The transient duration is from 25µs before the slot boundary to 25µs after the slot boundary. The power is measured with a filter that has a Root-Raised Cosine (RRC) filter response with a roll off $\alpha = 0.22$ and a bandwidth equal to the chip rate.

Table 5.6.1: Transmitter power step tolerance

Power control step size (Up or down) ΔP [dB]	Transmitter power step tolerance
0	+/- 0.5 dB
1	+/- 0.5 dB
2	+/- 1.0 dB
3	+/- 1.5 dB
$4 \leq \Delta P \leq 10$	+/- 2.0 dB
$11 \leq \Delta P \leq 15$	+/- 3.0 dB
$16 \leq \Delta P \leq 20$	+/- 4.0 dB
$21 \leq \Delta P$	+/- 6.0 dB

Clause C.2.1 defines the UL reference measurement channels (12,2 kbps) for TX test and the power ratio between DPCCH and DPDCH as -5.46 dB. Therefore, only one power control step size is selected as minimum requirement from Table 5.6.1. The accuracy of the power step, given the step size is specified in Table 5.6.2.

Table 5.6.2: Transmitter power step tolerance for test

Quantized amplitude ratios β_c and β_d	Power control step size (Up or down) ΔP [dB]	Transmitter power step tolerance
$\beta_c = 0.5333, \beta_d = 1.0$	7	+/- 2 dB

The transmit power levels versus time shall meet the mask specified in Figure 5.6.1.

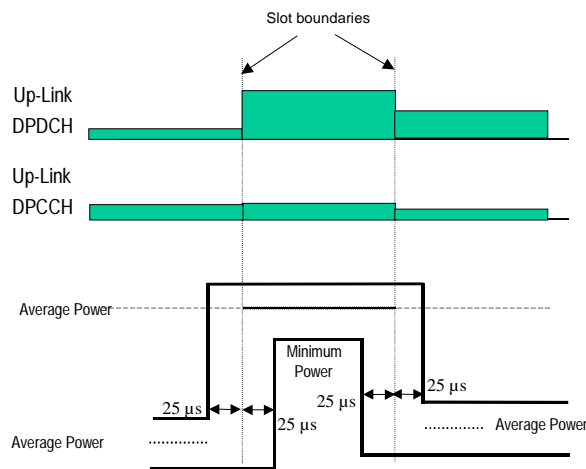

Figure 5.6.1: Transmit template during TFC change

The UL reference measurement channel (12.2 kbps) is a fixed rate channel. Therefore, DTX, where the DPDCH is turned off, is tested, as shown in Figure 5.6.2.

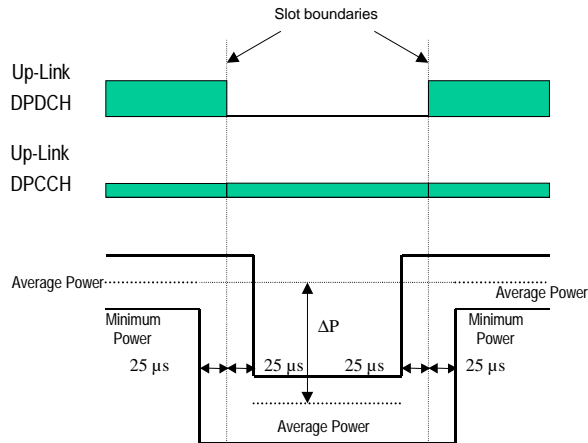

Figure 5.6.2: Transmit template during DTX

The reference for this requirement is [1] TS 25.101 subclause 6.5.3.1.

5.6.3 Test purpose

To verify that the tolerance of power control step size does not exceed the described value shown in Table 5.6.2.

To verify that the DTX ON/OFF power levels versus time meets the described mask shown in Figure 5.6.2.

5.6.4 Method of test

5.6.4.1 ~~5.6.4.1~~ Initial conditions

Test environment: normal; see subclauses G.2.1 and G.2.2.

Frequencies to be tested: mid range; see subclause G.2.4.

- 1) Connect the SS to the UE antenna connector as shown in Figure A.1.
- 2) A call is set up according to the Generic call setup procedure. The Uplink DPCH Power Control Info shall specify the Power Control Algorithm as algorithm 2 for interpreting TPC commands.
- 3) Enter the UE into loopback test mode and start the loopback test.

See [3] TS 34.108 and [4] TS 34.109 for details regarding generic call setup procedure and loopback test.

5.6.4.2 Procedure

- 1) Set the attenuation in the downlink signal (\hat{I}_{Or}) to yield an open loop output power, measured at the UE antenna connector, of 0 dBm.
- 2) Send alternating “0” and “1” TPC commands in the downlink so as to satisfy the condition of obtaining $TPC_cmd = 0$.
- 3) Using the Tester, measure the average output power at the antenna connector of the UE in two cases, both DPDCH and DPCCH are ON and only DPCCH is ON. The measurements shall not include the transient periods.

5.6.5 Test requirements

The difference in mean output power between DPDCH ON and OFF, derived in step 3), shall not exceed the prescribed range in Table 5.6.2.

5.7 Power setting in uplink compressed mode

5.7.1 Definition and applicability

Compressed mode in uplink means that the power in uplink is changed.

The requirements and this test apply to all types of UTRA for the FDD UE.

5.7.2 Conformance requirements

A change of output power is required during uplink compressed frames since the transmission of data is performed in a shorter interval. The ratio of the amplitude between the DPDCH codes and the DPCCH code will also vary. The power step due to compressed mode shall be calculated in the UE so that the energy transmitted on the pilot bits during each transmitted slot shall follow the inner loop power control.

Thereby, the power during compressed mode, and immediately afterwards, shall be such that the power on the DPCCH follows the steps due to inner loop power control combined with additional steps of $10\text{Log}_{10}(N_{\text{pilot,prev}} / N_{\text{pilot,curr}})$ dB where $N_{\text{pilot,prev}}$ is the number of pilot bits in the previously transmitted slot, and $N_{\text{pilot,curr}}$ is the current number of pilot bits per slot.

The resulting step in total transmitted power (DPCCH + DPDCH) shall then be rounded to the closest integer dB value. A power step exactly half-way between two integer values shall be rounded to the closest integer of greatest magnitude. The accuracy of the power step, given the step size, is specified in Table 5.6.1 in subclause 5.6.2. The power step is defined as the relative power difference between the average power of the original (reference) timeslot and the average power of the target timeslot, when neither the original timeslot nor the reference timeslot are in a transmission gap. The transient duration is not included, and is from 25 μ s before the slot boundary to 25 μ s after the slot boundary. The relative power is measured with a filter that has a Root-Raised Cosine (RRC) filter response with a roll off $\alpha = 0.22$ and a bandwidth equal to the chip rate.

In addition to any power change due to the ratio $N_{\text{pilot,prev}} / N_{\text{pilot,curr}}$, the average power of the DPCCH in the first slot after a compressed mode transmission gap shall differ from the average power in the last slot before the transmission gap by an amount Δ_{RESUME} , where Δ_{RESUME} is calculated as described in subclause 5.1.2.3 of [5] TS 25.214.

The resulting difference in the total transmitted power (DPCCH + DPDCH) shall then be rounded to the closest integer dB value. A power difference exactly half-way between two integer values shall be rounded to the closest integer of greatest magnitude. The accuracy of the resulting difference in the total transmitted power (DPCCH + DPDCH) after a transmission gap of up to 14 slots shall be as specified in Table 5.7.1.

Table 5.7.1: Transmitter power difference tolerance after a transmission gap of up to 14 slots

Tolerance on required difference in total transmitter power after a transmission gap
+/- 3 dB

The power difference is defined as the relative power difference between the average power of the original (reference) timeslot before the transmission gap and the average power of the target timeslot after the transmission gap, not including the transient durations. The transient durations at the start and end of the transmission gaps are each from 25 μ s before the slot boundary to 25 μ s after the slot boundary. The relative power is measured with a filter that has a Root-Raised Cosine (RRC) filter response with a roll off $\alpha = 0.22$ and a bandwidth equal to the chip rate.

The transmit power levels versus time shall meet the mask specified in Figure 5.7.1.

The reference for this requirement is [1] TS 25.101 subclause 6.5.4.1.

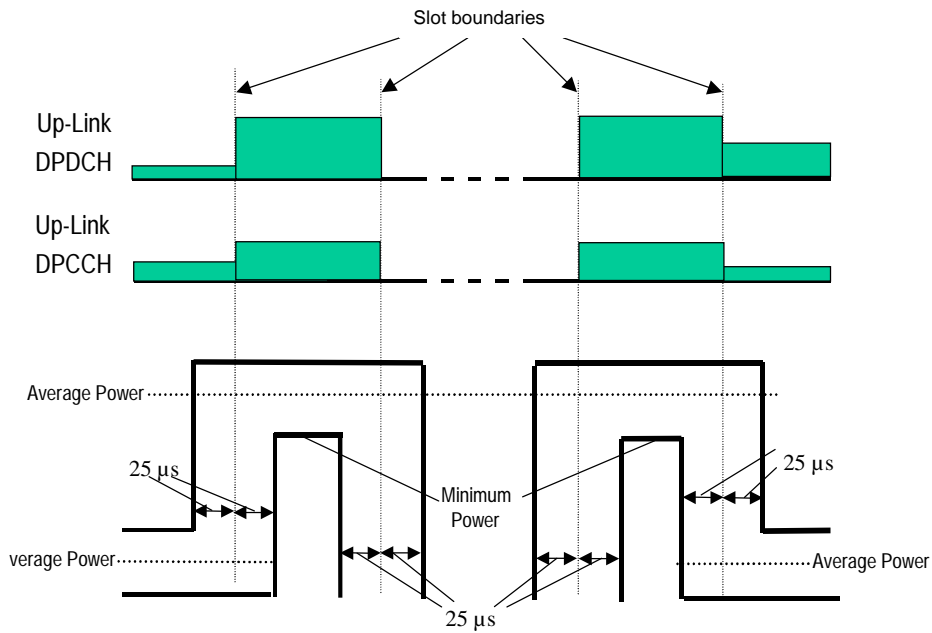

Figure 5.7.1: Transmit template during Compressed mode

The mean power in the transmission gaps, not including the transition periods, shall be less than -56 dBm. The reference for this requirement is [1] TS 25.101 subclause 6.5.1.1.

For RPL (Recovery Period Length) slots after the transmission gap, where RPL is the minimum out of the transmission gap length and 7 slots, the UE shall use the power control algorithm and step size specified by the signalled Recovery Period Power Control Mode (RPP), as detailed in TS 25.214 subclause 5.1.2.3.

When nominal 3 dB power control steps are used in the recovery period, the transmitter output power steps due to inner loop power control shall be within the range shown in Table 5.7.2, and the transmitter average output power step due to inner loop power control shall be within the range shown in Table 5.7.3, excluding any other power changes due, for example, to changes in spreading factor or number of pilot bits.

Table 5.7.2: Transmitter power control range for 3dB step size

TPC_cmd	Transmitter power control range for 3dB step size	
	Lower	Upper
+ 1	+1.5 dB	+4.5 dB
0	-0.5 dB	+0.5 dB
- 1	-1.5 dB	-4.5 dB

Table 5.7.3: Transmitter average power control range for 3dB step size

TPC_cmd group	Transmitter power control range after 7 equal TPC_cmd groups	
	Lower	Upper
+ 1	+16 dB	+26 dB
0	-1 dB	+1 dB
- 1	-16 dB	-26 dB

The reference for this requirement is [1] TS 25.101 subclause 6.4.2.1.1.

5.7.3 Test purpose

To verify that the changes in uplink transmit power in compressed mode are within the prescribed tolerances.

Excess error in transmit power setting in compressed mode increases the interference to other channels, or increases transmission errors in the uplink.

5.7.4 Method of test

5.7.4.1 ~~5.7.4.1~~—Initial conditions

Test environment: normal; see subclauses G.2.1 and G.2.2.

Frequencies to be tested: mid range; see subclause G.2.4.

- 1) Connect the SS to the UE antenna connector as shown in Figure A.1.
- 2) A call is set up according to the Generic call setup procedure. The 12.2 kbps UL reference measurement channel is used, with gain factors $\beta_c = 0.5333$ and $\beta_d = 1.0$ in non-compressed frames. Slot formats 0, 0A and 0B are used on the uplink DPCCCH.
- 3) Enter the UE into loopback test mode and start the loopback test.

See [3] TS 34.108 and [4] TS 34.109 for details regarding generic call setup procedure and loopback test.

5.7.4.2 Procedure

NOTE: CFNs are given in this procedure for reference as examples only. A fixed offset may be applied to the CFNs.

- 1) Before proceeding with paragraph (4) below, set the output power of the UE, measured at the UE antenna connector, to be in the range -34 ± 9 dBm. This may be achieved by setting the downlink signal (\hat{I}_0) to yield an appropriate open loop output power and/or by generating suitable downlink TPC commands from the SS.
- 2) Signal the uplink power control parameters to use Algorithm 1 and a step size of 2 dB.
- 3) Signal the set of compressed mode parameters shown in Table 5.7.5. This set of compressed mode parameters defines the compressed mode pattern which is used to test the implementation of 3dB output power steps and the implementation of a power change when resuming transmission after a compressed mode gap.

Table 5.7.5: Parameters for pattern A for compressed mode test

Parameter	Meaning	Value
TGPRC	Number of transmission gap patterns within the Transmission Gap Pattern Sequence	1
TGCFN	Connection Frame Number of the first frame of the first pattern within the Transmission Gap Pattern Sequence	0
TGSN	Slot number of the first transmission gap slot within the TGCFN	10
TGL1	Length of first transmission gap within the transmission gap pattern	10 slots
TGL2	Length of second transmission gap within the transmission gap pattern	5 slots
TGD	Duration between the starting slots of two consecutive transmission gaps within a transmission gap pattern	20 slots
TGPL1	Duration of transmission gap pattern 1	3 frames
TGPL2	Duration of transmission gap pattern 2	Omit
RPP	Recovery Period Power Control Mode	Mode 1
ITP	Initial Transmit Power Mode	Mode 1
UL/DL Mode	Defines whether only DL, only UL, or combined UL/DL compressed mode is used	UL/DL
Downlink Compressed Mode Method	Method for generating downlink compressed mode gap	SF/2
Uplink Compressed Mode Method	Method for generating uplink compressed mode gap	SF/2
Scrambling code change	Indicates whether the alternative scrambling code is used	No code change
Downlink frame type	Downlink compressed frame structure	A
DeltaSIR	Delta in DL SIR target value to be set in the UE during compressed frames	0
DeltaSIRafter	Delta in DL SIR target value to be set in the UE one frame after the compressed frames	0

The resulting compressed mode pattern is shown in Figure 5.7.2.

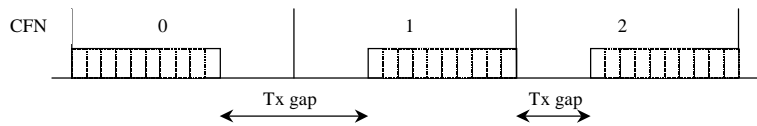

Figure 5.7.2: Pattern A for compressed mode test

- 4) Transmit TPC commands on the downlink as shown in Table 5.7.6:

Table 5.7.6: TPC commands transmitted in downlink

CFN	TPC commands in downlink
0	1 1 1 1 1 1 1 1 1 1 - - - - -
1	- - - - - 1 1 1 1 1 1 1 1 0 0
2	- - - - - 0 1 0 1 0 1 0 1 0 1

- 5) Measure the mean output power in the following slots, not including the 25µs transient periods at the start and end of each slot:

CFN 1: Slots # 5,6,7,8,9,10,11,12,14
 CFN 2: Slot # 5

Also measure the mean output power in each transmission gap, not including the 25µs transient periods at the start and end of each transmission gap.

- 6) Re-start the test. Before proceeding with step (8) below, set the output power of the UE, measured at the UE antenna connector, to be in the range 3±9dBm. This may be achieved by, setting the downlink signal (\hat{I} or) to yield an appropriate open loop output power and/or by generating suitable downlink TPC commands from the SS.
- 7) Repeat steps (2) and (3) above, with the exception that TGCFN = 3.
- 8) Transmit TPC commands on the downlink as shown in Table 5.7.7:

Table 5.7.7: TPC commands transmitted in downlink

CFN	TPC commands in downlink
3	0 0 0 0 0 0 0 0 0 0 - - - - -
4	- - - - - 0 0 0 0 0 0 0 0 1 1
5	- - - - - 1 0 1 0 1 0 1 0 1 0

- 9) Measure the mean output power in the following slots, not including the 25µs transient periods at the start and end of each slot:

CFN 4: Slots # 5,6,7,8,9,10,11,12,14
 CFN 5: Slot # 5

Also measure the mean output power in each transmission gap, not including the 25µs transient periods at the start and end of each transmission gap.

- 10) Re-start the test. Before proceeding with step (13) below, set the output power of the UE, measured at the UE antenna connector, to be in the range -10±9dBm. This may be achieved by setting the downlink signal (\hat{I} or) to yield an appropriate open loop output power and/or by generating suitable downlink TPC commands from the SS.
- 11) Signal the uplink power control parameters to use Algorithm 1 and a step size of 1 dB.

12) Signal the set of compressed mode parameters shown in Table 5.7.8. This set of compressed mode parameters defines the compressed mode pattern which is used to test the implementation of power steps at the start and end of compressed frames, and the implementation of a zero power change when resuming transmission after a compressed mode gap.

Table 5.7.8: Parameters for pattern B for compressed mode test

Parameter	Meaning	Value
TGPRC	Number of transmission gap patterns within the Transmission Gap Pattern Sequence	1
TGCFN	Connection Frame Number of the first frame of the first pattern within the Transmission Gap Pattern Sequence	7
TGSN	Slot number of the first transmission gap slot within the TGCFN	8
TGL1	Length of first transmission gap within the transmission gap pattern	14 slots
TGL2	Length of second transmission gap within the transmission gap pattern	omit
TGD	Duration between the starting slots of two consecutive transmission gaps within a transmission gap pattern	0
TGPL1	Duration of transmission gap pattern 1	4 frames
TGPL2	Duration of transmission gap pattern 2	Omit
RPP	Recovery Period Power Control Mode	Mode 0
ITP	Initial Transmit Power Mode	Mode 0
UL/DL Mode	Defines whether only DL, only UL, or combined UL/DL compressed mode is used	UL/DL
Downlink Compressed Mode Method	Method for generating downlink compressed mode gap	SF/2
Uplink Compressed Mode Method	Method for generating uplink compressed mode gap	SF/2
Scrambling code change	Indicates whether the alternative scrambling code is used	No code change
Downlink frame type	Downlink compressed frame structure	A
DeltaSIR	Delta in DL SIR target value to be set in the UE during compressed frames	0
DeltaSIRafter	Delta in DL SIR target value to be set in the UE one frame after the compressed frames	0

The resulting compressed mode pattern is shown in Figure 5.7.3.

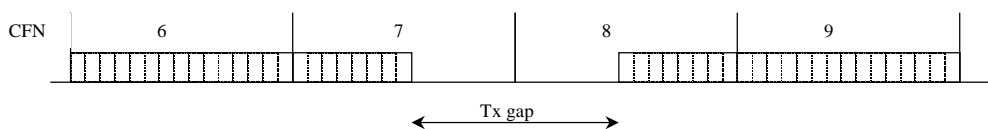

Figure 5.7.3: Pattern B for compressed mode test

13) Transmit TPC commands on the downlink as shown in Table 5.7.8:

Table 5.7.8: TPC commands transmitted in downlink

CFN	TPC commands in downlink
6	000000000000111
7	11111111-----
8	-----0000000
9	000111111111111

14) Measure the mean output power in the following slots, not including the 25µs transient periods at the start and end of each slot:

- CFN 6: Slot # 14
- CFN 7: Slots # 0 and 7
- CFN 8: Slots # 7 and 14
- CFN 9: Slot # 0

Also measure the mean output power in the transmission gap, not including the 25µs transient periods at the start and end of the transmission gap.

5.7.5 Test requirements

For ease of reference, the following uplink output power measurements are defined in Figure 5.7.4. In this figure:

- P_g is the mean power in an uplink transmission gap, excluding the 25 µs transient periods.
- P_a is the mean power in the last slot before a compressed frame (or pair of compressed frames), excluding the 25 µs transient periods.
- P_b is the mean power in the first slot of a compressed frame, excluding the 25 µs transient periods.
- P_c is the mean power in the last slot before a transmission gap, excluding the 25 µs transient periods.
- P_d is the mean power in the first slot after a transmission gap, excluding the 25 µs transient periods.
- P_e is the mean power in the last slot of a compressed frame, excluding the 25 µs transient periods.
- P_f is the mean power in the first slot after a compressed frame (or pair of compressed frames), excluding the 25 µs transient periods.

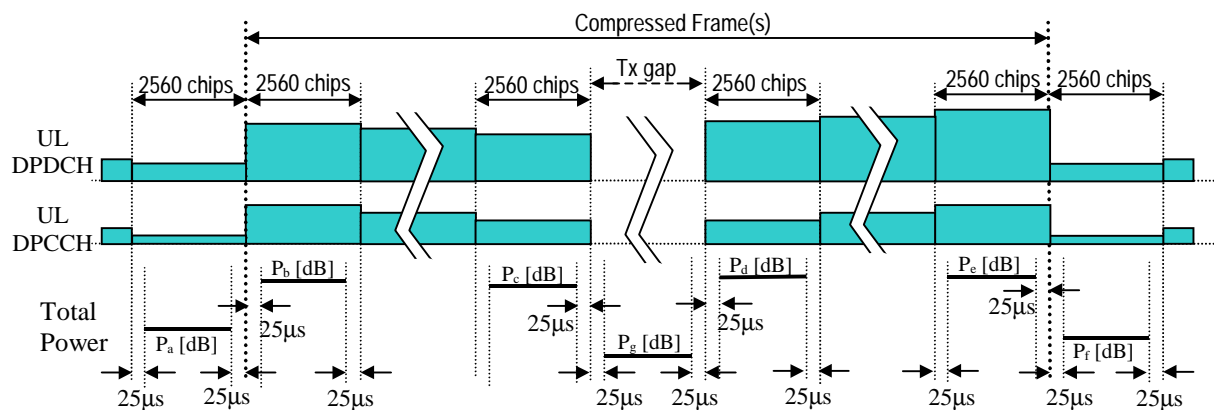

Figure 5.7.4: Uplink transmit power in uplink compressed mode

1. At the boundary between CFN 6 and CFN 7, $P_b - P_a$ shall be within the range $+4 \pm 2$ dB.
2. In slot #5 of CFN 2, the power difference $P_d - P_c$ from the power in slot #14 of CFN 1 shall be within the range -6 ± 3 dB.
3. In slot #5 of CFN 5, the power difference $P_d - P_c$ from the power in slot #14 of CFN 4 shall be within the range $+6 \pm 3$ dB.
4. In slot #7 of CFN 8, the power difference $P_d - P_c$ from the power in slot #7 of CFN 7 shall be within the range 0 ± 3 dB.
5. In CFNs 0, 1, 2, 3, 4, 5, 7 and 8, P_g shall be less than -56 dBm.
6. At the boundary between CFN 8 and CFN 9, $P_f - P_e$ shall be within the range -4 ± 2 dB.

7. In the slots between slot #6 of CFN 1 and slot #12 of CFN 1 inclusive, the change in mean output power from the previous slot shall be within the range given in Table 5.7.2 for TPC_cmd = +1.
8. The aggregate change in mean output power from slot #5 of CFN 1 to slot #12 of CFN 1 shall be within the range given in Table 5.7.3 for TPC_cmd = +1.
9. In the slots between slot #6 of CFN 4 and slot #12 of CFN 4 inclusive, the change in mean output power from the previous slot shall be within the range given in Table 5.7.2 for TPC_cmd = -1.
10. The aggregate change in mean output power from slot #5 of CFN 4 to slot #12 of CFN 4 shall be within the range given in Table 5.7.3 for TPC_cmd = -1.

5.8 Occupied Bandwidth (OBW)

5.8.1 Definition and applicability

Occupied bandwidth is a measure of the bandwidth containing 99 % of the total integrated power of the transmitted spectrum, centred on the assigned channel frequency.

The requirements and this test apply to all types of UTRA for the FDD UE.

5.8.2 Minimum Requirements

The occupied channel bandwidth shall be less than 5 MHz based on a chip rate of 3.84 Mcps.

The normative reference for this requirement is [1] TS 25.101 subclause 6.6.1.

5.8.3 Test purpose

To verify that the UE occupied channel bandwidth is less than 5 MHz based on a chip rate of 3.84 Mcps.

Excess occupied channel bandwidth increases the interference to other channels or to other systems.

5.8.4 Method of test

5.8.4.1 ~~5.8.4.1~~ Initial conditions

Test environment: normal; see subclauses G.2.1 and G.2.2.

Frequencies to be tested: low range, mid range, high range; see subclause G.2.4.

- 1) Connect the SS to the UE antenna connector as shown in Figure A.1.
- 2) A call is set up according to the Generic call setup procedure
- 3) Enter the UE into loopback test mode and start the loopback test.

See [3] TS 34.108 and [4] TS 34.109 for details regarding generic call setup procedure and loopback test.

5.8.4.2 Procedure

- 1) Set and send continuously Up power control commands to the UE until the UE output power shall be maximum level.
- 2) Measure the power spectrum distribution within two times or more range over the requirement for Occupied Bandwidth specification centring on the current carrier frequency with 30 kHz or less RBW. The characteristic of the filter shall be approximately Gaussian (typical spectrum analyzer filter).
- 3) Calculate the total power within the range of all frequencies measured in '2)' and save this value as "Total Power".

- 4) Sum up the power upward from the lower boundary of the measured frequency range in '2)' and seek the limit frequency point by which this sum becomes 0.5 % of "Total Power" and save this point as "Lower Frequency".
- 5) Sum up the power downward from the upper boundary of the measured frequency range in '2)' and seek the limit frequency point by which this sum becomes 0.5 % of "Total Power" and save this point as "Upper Frequency".
- 6) Calculate the difference ("Upper Frequency" – "Lower Frequency" = "Occupied Bandwidth") between two limit frequencies obtained in '4)' and '5)'.

5.8.5 Test Requirements

The measured Occupied Bandwidth, derived in step 6), shall not exceed 5 MHz.

NOTE: If the above Test Requirement differs from the Minimum Requirement then the Test Tolerance applied for this test is non-zero. The Test Tolerance for this test is defined in Annex F.2 and the explanation of how the Minimum Requirement has been relaxed by the Test Tolerance is given in Annex F.4.

5.9 Spectrum emission mask

5.9.1 Definition and applicability

The spectrum emission mask of the UE applies to frequencies, which are between 2.5 MHz and 12.5 MHz away from the UE centre carrier frequency. The out of channel emission is specified relative to the UE output power measured in a 3.84 MHz bandwidth.

The requirements and this test apply to all types of UTRA for the FDD UE.

5.9.2 Minimum Requirements

The power of any UE emission shall not exceed the levels specified in Table 5.9.1.

Table 5.9.1: Spectrum Emission Mask Requirement

Frequency offset from carrier Δf	Minimum requirement	Measurement bandwidth
2.5 - 3.5 MHz	$-35 - 15*(\Delta f - 2.5)$ dBc	30 kHz *
3.5 - 7.5 MHz	$-35 - 1*(\Delta f - 3.5)$ dBc	1 MHz *
7.5 - 8.5 MHz	$-39 - 10*(\Delta f - 7.5)$ dBc	1 MHz *
8.5 - 12.5 MHz	-49 dBc	1 MHz *

NOTE*:

1. The first and last measurement position with a 30 kHz filter is 2.515 MHz and 3.485 MHz.
2. The first and last measurement position with a 1 MHz filter is 4 MHz and 12 MHz. As a general rule, the resolution bandwidth of the measuring equipment should be equal to the measurement bandwidth. To improve measurement accuracy, sensitivity and efficiency, the resolution bandwidth can be different from the measurement bandwidth. When the resolution bandwidth is smaller than the measurement bandwidth, the result should be integrated over the measurement bandwidth.
3. The lower limit shall be -50 dBm / 3.84 MHz or which ever is higher.

The normative reference for this requirement is [1] TS 25.101 subclause 6.6.2.1.1.

5.9.3 Test purpose

To verify that the power of UE emission does not exceed the prescribed limits shown in Table 5.9.1.

Excess emission increases the interference to other channels or to other systems.

5.9.4 Method of test

5.9.4.1 ~~5.9.4.1~~ Initial conditions

Test environment: normal; see subclauses G.2.1 and G.2.2.

Frequencies to be tested: low range, high range; see subclause G.2.4.

- 1) Connect the SS to the UE antenna connector as shown in Figure A.1.
- 2) A call is set up according to the Generic call setup procedure.
- 3) Enter the UE into loopback test mode and start the loopback test.

See [3] TS 34.108 and [4] TS 34.109 for details regarding generic call setup procedure and loopback test.

5.9.4.2 Procedure

- 1) Set and send continuously Up power control commands to the UE until the UE output power shall be maximum level.
- 2) Measure the power of the transmitted signal with a measurement filter of bandwidths according to Table 5.9.2. Measurements with an offset from the carrier centre frequency between 2.515 MHz and 3.485 MHz shall use a 30 kHz measurement filter. Measurements with an offset from the carrier centre frequency between 4 MHz and 12 MHz shall use 1 MHz measurement bandwidth and the result may be calculated by integrating multiple 50 kHz or narrower filter measurements. The characteristic of the filter shall be approximately Gaussian (typical spectrum analyzer filter). The centre frequency of the filter shall be stepped in contiguous steps according to Table 5.9.2. The measured power shall be recorded for each step.
- 3) Measure the wanted output power according to Annex B.
- 4) Calculate the ratio of the power 2) with respect to 3) in dBc.

5.9.5 Test requirements

The result of 5.9.4.2 step 4) shall fulfil the requirements of Table 5.9.2.

Table 5.9.2: Spectrum Emission Mask Requirement

Frequency offset from carrier Δf	Minimum requirement	Measurement bandwidth
2.5 - 3.5 MHz	$-33.5 - 15*(\Delta f - 2.5)$ dBc	30 kHz *
3.5 - 7.5 MHz	$-33.5 - 1*(\Delta f - 3.5)$ dBc	1 MHz *
7.5 - 8.5 MHz	$-37.5 - 10*(\Delta f - 7.5)$ dBc	1 MHz *
8.5 - 12.5 MHz	-47.5 dBc	1 MHz *

NOTE*:

1. The first and last measurement position with a 30 kHz filter is 2.515 MHz and 3.485 MHz.
2. The first and last measurement position with a 1 MHz filter is 4 MHz and 12 MHz. As a general rule, the resolution bandwidth of the measuring equipment should be equal to the measurement bandwidth. To improve measurement accuracy, sensitivity and efficiency, the resolution bandwidth can be different from the measurement bandwidth. When the resolution bandwidth is smaller than the measurement bandwidth, the result should be integrated over the measurement bandwidth.
3. The lower limit shall be -48.5 dBm / 3.84 MHz or which ever is higher.
4. If the above Test Requirement differs from the Minimum Requirement then the Test Tolerance applied for this test is non-zero. The Test Tolerance for this test is defined in Annex F.2 and the explanation of how the Minimum Requirement has been relaxed by the Test Tolerance is given in Annex F.4.

5.10 Adjacent Channel Leakage Power Ratio (ACLR)

5.10.1 Definition and applicability

ACLR is the ratio of the transmitted power to the power measured in an adjacent channel. Both the transmitted power and the adjacent channel power are measured with a filter that has a Root-Raised Cosine (RRC) filter response with roll-off $\alpha=0.22$ and a bandwidth equal to the chip rate.

The requirements and this test apply to all types of UTRA for the FDD UE.

5.10.2 Minimum Requirements

If the adjacent channel power is greater than -50dBm then the ACLR should be higher than the value specified in Table 5.10.1.

Table 5.10.1: UE ACLR due to modulation

Power Class	UE channel	ACLR limit
3	+ 5 MHz or – 5 MHz	33 dB
	+ 10 MHz or – 10 MHz	43 dB
4	+ 5 MHz or – 5 MHz	33 dB
	+ 10 MHz or – 10 MHz	43 dB

The normative reference for this requirement is [1] TS 25.101 subclause 6.6.2.2.1.

5.10.3 Test purpose

To verify that the UE ACLR due to modulation does not exceed prescribed limit shown in Table 5.10.1.

Excess ACLR increase the interference to other channels or to other systems.

5.10.4 Method of test

5.10.4.1 ~~5.10.4.1~~ Initial conditions

Test environment: normal, TL/VL, TL/VH, TH/VL, TH/VH; see subclauses G.2.1 and G.2.2.

Frequencies to be tested: low range, mid range, high range; see subclause G.2.4.

- 1) Connect the SS to the UE antenna connector as shown in Figure A.1.
- 2) A call is set up according to the Generic call setup procedure.
- 3) Enter the UE into loopback test mode and start the loopback test.

See [3] TS 34.108 and [4] TS 34.109 for details regarding generic call setup procedure and loopback test.

5.10.4.2 Procedure

- 1) Set and send continuously Up power control commands to the UE until the UE output power shall be maximum level.
- 2) Measure the power within the bandwidth of current carrier through a matched filter (RRC 0.22).
- 3) Measure the power fallen in the bandwidth of the first adjacent channels and the second adjacent channels through a matched filter (RRC 0.22).
- 4) Calculate the ratio of the power between the values measured in '2)' and '3)'.

5.10.5 Test requirements

If the measured adjacent channel power, derived in step 3), is greater than -50dBm then the measured ACLR, derived in step 4), shall be higher than the limit in Table 5.10.2.

Table 5.10.2: UE ACLR due to modulation

Power Class	UE channel	ACLR limit
3	+ 5 MHz or – 5 MHz	32.2 dB
	+ 10 MHz or – 10 MHz	42.2 dB
4	+ 5 MHz or – 5 MHz	32.2 dB
	+ 10 MHz or – 10 MHz	42.2 dB

NOTE: If the above Test Requirement differs from the Minimum Requirement then the Test Tolerance applied for this test is non-zero. The Test Tolerance for this test is defined in Annex F.2 and the explanation of how the Minimum Requirement has been relaxed by the Test Tolerance is given in Annex F.4.

5.11 Spurious Emissions

5.11.1 Definition and applicability

Spurious emissions are emissions which are caused by unwanted transmitter effects such as harmonics emission, parasitic emission, intermodulation products and frequency conversion products, but exclude out of band emissions.

The frequency boundary and the detailed transitions of the limits between the requirement for out band emissions and spectrum emissions are based on ITU-R Recommendations SM.329.

The requirements and this test apply to all types of UTRA for the FDD UE.

5.11.2 Minimum Requirements

These requirements are only applicable for frequencies, which are greater than 12.5 MHz away from the UE centre carrier frequency.

Table 5.11.1a: General spurious emissions requirements

Frequency Bandwidth	Resolution Bandwidth	Minimum requirement
$9\text{ kHz} \leq f < 150\text{ kHz}$	1 kHz	-36 dBm
$150\text{ kHz} \leq f < 30\text{ MHz}$	10 kHz	-36 dBm
$30\text{ MHz} \leq f < 1000\text{ MHz}$	100 kHz	-36 dBm
$1\text{ GHz} \leq f < 12.75\text{ GHz}$	1 MHz	-30 dBm

Table 5.11.1b: Additional spurious emissions requirements

Frequency Bandwidth	Resolution Bandwidth	Minimum requirement
$1893.5\text{ MHz} < f < 1919.6\text{ MHz}$	300 kHz	-41 dBm
$925\text{ MHz} \leq f \leq 935\text{ MHz}$	100 kHz	-67 dBm^*
$935\text{ MHz} < f \leq 960\text{ MHz}$	100 kHz	-79 dBm^*
$1805\text{ MHz} \leq f \leq 1880\text{ MHz}$	100 kHz	-71 dBm^*

*NOTE: The measurements are made on frequencies which are integer multiples of 200 kHz. As exceptions, up to five measurements with a level up to the applicable requirements defined in Table 5.11.1b are permitted for each UARFCN used in the measurement.

The normative reference for this requirement is [1] TS 25.101 subclause 6.6.3.1.

5.11.3 Test purpose

To verify that the UE spurious emissions do not exceed described value shown in Table 5.11.1a and Table 5.11.1b.

Excess spurious emissions increase the interference to other systems.

5.11.4 Method of test

5.11.4.1 ~~5.11.4.1~~ Initial conditions

Test environment: normal; see subclauses G.2.1 and G.2.2.

Frequencies to be tested: low range, mid range, high range; see subclause G.2.4.

- 1) Connect the SS to the UE antenna connector as shown in Figure A.8.
- 2) A call is set up according to the Generic call setup procedure.
- 3) Enter the UE into loopback test mode and start the loopback test.

See [3] TS 34.108 and [4] TS 34.109 for details regarding generic call setup procedure and loopback test.

5.11.4.2 Procedure

- 1) Set and send continuously Up power control commands to the UE until the UE output power shall be maximum level.
- 2) Sweep the spectrum analyzer (or equivalent equipment) over a frequency range and measure the average power of spurious emission.

5.11.5 Test requirements

The measured average power of spurious emission, derived in step 2), shall not exceed the described value in Table 5.11.2a and 5.11.2b.

These requirements are only applicable for frequencies, which are greater than 12.5 MHz away from the UE centre carrier frequency.

Table 5.11.2a: General spurious emissions test requirements

Frequency Bandwidth	Resolution Bandwidth	Minimum requirement
$9 \text{ kHz} \leq f < 150 \text{ kHz}$	1 kHz	-36 dBm
$150 \text{ kHz} \leq f < 30 \text{ MHz}$	10 kHz	-36 dBm
$30 \text{ MHz} \leq f < 1000 \text{ MHz}$	100 kHz	-36 dBm
$1 \text{ GHz} \leq f < 12.75 \text{ GHz}$	1 MHz	-30 dBm

Table 5.11.2b: Additional spurious emissions test requirements

Frequency Bandwidth	Resolution Bandwidth	Minimum requirement
$1893.5 \text{ MHz} < f < 1919.6 \text{ MHz}$	300 kHz	-41 dBm
$925 \text{ MHz} \leq f \leq 935 \text{ MHz}$	100 kHz	-67 dBm *
$935 \text{ MHz} < f \leq 960 \text{ MHz}$	100 kHz	-79 dBm *
$1805 \text{ MHz} \leq f \leq 1880 \text{ MHz}$	100 kHz	-71 dBm *

NOTE:

1. The measurements are made on frequencies which are integer multiples of 200 kHz. As exceptions, up to five measurements with a level up to the applicable requirements defined in Table 5.11.2b are permitted for each UARFCN used in the measurement.

2. If the above Test Requirement differs from the Minimum Requirement then the Test Tolerance applied for this test is non-zero. The Test Tolerance for this test is defined in Annex F.2 and the explanation of how the Minimum Requirement has been relaxed by the Test Tolerance is given in Annex F.4.

5.12 Transmit Intermodulation

5.12.1 Definition and applicability

The transmit intermodulation performance is a measure of the capability of the transmitter to inhibit the generation of signals in its non linear elements caused by presence of the wanted signal and an interfering signal reaching the transmitter via the antenna.

UE(s) transmitting in close vicinity of each other can produce intermodulation products, which can fall into the UE, or Node B receive band as an unwanted interfering signal. The UE transmit intermodulation attenuation is defined by the ratio of the output power of the wanted signal to the output power of the intermodulation product when an interfering CW signal is added at a level below the wanted signal. Both the wanted signal power and the IM product power are measured with a filter that has a Root-Raised Cosine (RRC) filter response with roll-off $\alpha = 0,22$ and a bandwidth equal to the chip rate.

The requirements and this test apply to all types of UTRA for the FDD UE.

5.12.2 Minimum Requirements

The UE transmit intermodulation shall not exceed the described value in Table 5.12.1.

Table 5.12.1: Transmit Intermodulation

CW Signal Frequency Offset from Transmitting Carrier	5MHz	10MHz
Interference CW Signal Level	-40 dBc	
Intermodulation Product	-31 dBc	-41 dBc

The normative reference for this requirement is [1] TS 25.101 subclause 6.7.1.

5.12.3 Test purpose

To verify that the UE transmit intermodulation does not exceed the described value in Table 5.12.1.

An excess transmit intermodulation increases transmission errors in the up link own channel when other transmitter exists nearby.

5.12.4 Method of test

5.12.4.1 ~~5.12.4.1~~ Initial conditions

Test environment: normal; see subclauses G.2.1 and G.2.2.

Frequencies to be tested: mid range; see subclause G.2.4.

- 1) Connect the SS to the UE antenna connector as shown in Figure A.2.
- 2) A call is set up according to the Generic call setup procedure.
- 3) Enter the UE into loopback test mode and start the loopback test.

See [3] TS 34.108 and [4] TS 34.109 for details regarding generic call setup procedure and loopback test.

5.12.4.2 Procedure

- 1) Set and send continuously Up power control commands to the UE until the UE output power shall be maximum level.
- 2) Set the frequency of the CW generator to the offset 1 or offset 2 as shown in Table 5.12.2.
- 3) Measure the average output power of the UE by spectrum analyzer (or equivalent equipment) through RRC filter.
- 4) Search the intermodulation product signal, then measure the average power of transmitting intermodulation through RRC filter, and calculate the ratio to the average output power of UE.
- 5) Repeat the measurement with another tone offset.

5.12.5 Test requirements

The measured average power of transmit intermodulation, derived in step 4), shall not exceed the described value in Table 5.12.2.

Table 5.12.2: Transmit Intermodulation

CW Signal Frequency Offset from Transmitting Carrier	5MHz	10MHz
Interference CW Signal Level	-40 dBc	
Intermodulation Product	$[-31 + TT]$ dBc	$[-41 + TT]$ dBc

NOTE: If the above Test Requirement differs from the Minimum Requirement then the Test Tolerance applied for this test is non-zero. The Test Tolerance for this test is defined in Annex F.2 and the explanation of how the Minimum Requirement has been relaxed by the Test Tolerance is given in Annex F.4.

5.13 Transmit Modulation

5.13.1 Error Vector Magnitude (EVM)

5.13.1.1 Definition and applicability

The Error Vector Magnitude (EVM) is a measure of the difference between the measured waveform and the theoretical modulated waveform (the error vector). It is the square root of the ratio of the mean error vector power to the mean reference signal power expressed as a %. The measurement interval is one power control group (timeslot).

The requirements and this test apply to all types of UTRA for the FDD UE.

5.13.1.2 Minimum Requirements

The EVM shall not exceed 17.5 % for the parameters specified in Table 5.13.1.

Table 5.13.1: Parameters for EVM

Parameter	Level / Status	Unit
Output power	≥ -20	dBm
Operating conditions	Normal conditions	
Power control step size	1	dB

The normative reference for this requirement is [1] TS 25.101 clause 6.8.2.1.

5.13.1.3 Test purpose

To verify that the EVM does not exceed 17.5 % for the specified parameters in Table 5.13.1.

An excess EVM increases transmission errors in the up link own channel.

5.13.1.4 Method of test

5.13.1.4.1 ~~5.13.1.4.1~~ Initial conditions

Test environment: normal, TL/VL, TL/VH, TH/VL, TH/VH, vibration; see subclauses G.2.1, G.2.2 and G.2.3.

Frequencies to be tested: low range, mid range, high range; see subclause G.2.4.

- 1) Connect the SS to the UE antenna connector as shown in Figure A.1.
- 2) A call is set up according to the Generic call setup procedure.
- 3) Enter the UE into loopback test mode and start the loopback test.

See [3] TS 34.108 and [4] TS 34.109 for details regarding generic call setup procedure and loopback test.

5.13.1.4.2 Procedure

- 1) Set and send continuously Up power control commands to the UE until the UE output power shall be maximum level.
- 2) Measure the EVM using Global In-Channel Tx-Test (Annex B).
- 3) Set the power level of UE to -20dBm or send Down power control commands (1dB step size should be used.) to the UE until UE output power shall be -20dBm with $\pm 1\text{dB}$ tolerance.
- 4) Repeat step 2).

5.13.1.5 Test requirements

The measured EVM, derived in step 2) and 4), shall not exceed 17.5% for parameters specified in table 5.13.1 Parameters for EVM.

NOTE: If the above Test Requirement differs from the Minimum Requirement then the Test Tolerance applied for this test is non-zero. The Test Tolerance for this test is defined in Annex F.2 and the explanation of how the Minimum Requirement has been relaxed by the Test Tolerance is given in Annex

5.13.2 Peak code domain error

5.13.2.1 Definition and applicability

The Peak Code Domain Error is computed by projecting power of the error vector (as defined in 5.13.1.1) onto the code domain at a specific spreading factor. The Code Domain Error for every code in the domain is defined as the ratio of the mean power of the projection onto that code, to the mean power of the composite reference waveform expressed in dB. The Peak Code Domain Error is defined as the maximum value for the Code Domain Error for all codes. The measurement interval is one power control group (timeslot).

The requirements and this test apply only to the UE in which the multi-code transmission is provided.

5.13.2.2 Minimum Requirements

The peak code domain error shall not exceed -15 dB at spreading factor 4 for the parameters specified in Table 5.13.3. The requirements are defined using the UL reference measurement channel (768 kbps) specified in subclause C.2.5.

Table 5.13.3: Parameters for Peak code domain error

Parameter	Level / Status	Unit
Output power	≥ -20	dBm
Operating conditions	Normal conditions	
Power control step size	1	dB

The normative reference for this requirement is [1] TS 25.101 subclause 6.8.3.1.

5.13.2.3 Test purpose

To verify that the UE peak code domain error does not exceed -15 dB for the specified parameters in Table 5.13.3.

An excess peak code domain error increases transmission errors in the up link own channel.

5.13.2.4 Method of test

5.13.2.4.1 ~~5.13.2.4.1~~ Initial conditions

Test environment: normal, TL/VL, TL/VH, TH/VL, TH/VH; see subclauses G.2.1 and G.2.2.

Frequencies to be tested: low range, mid range, high range; see subclause G.2.4.

- 1) Connect the SS to the UE antenna connector as shown in Figure A.1.
- 2) A call is set up according to the Generic call setup procedure, and RF parameters are set up according to Table 5.13.4.
- 3) Enter the UE into loopback test mode and start the loopback test.

See [3] TS 34.108 and [4] TS 34.109 for details regarding generic call setup procedure and loopback test.

Table 5.13.4: Test parameters for Peak code domain error

Parameter	Level / Status	Unit
Operating conditions	Normal conditions	
Uplink signal	multi-code	
Information bit rate	2*384	kbps
Power control step size	1	dB

5.13.2.4.2 Procedure

- 1) Set and send continuously Up power control commands to the UE until the UE output power shall be maximum level.
- 2) Measure the Peak code Domain error using Global In-Channel Tx-Test (Annex B).
- 3) Set the power level of UE to -20dBm or send Down power control commands (1dB step size should be used.) to the UE until UE output power shall be -20dBm with +/- 1dB tolerance.
- 4) Repeat step 2).

5.13.2.5 Test requirements

The measured Peak code domain error, derived in step 2) and 4), shall not exceed -14 dB.

NOTE: If the above Test Requirement differs from the Minimum Requirement then the Test Tolerance applied for this test is non-zero. The Test Tolerance for this test is defined in Annex F.2 and the explanation of how the Minimum Requirement has been relaxed by the Test Tolerance is given in Annex F.4

6 Receiver Characteristics

6.1 General

Receiving performance test of the UE is implemented during communicating with the SS via air interface. The procedure is using normal call protocol until the UE is communicating on traffic channel basically. On the traffic channel, the UE provides special function for testing that is called Logical Test Interface and the UE is tested using this function (Refer to [4] TS 34.109)

Transmitting or receiving bit/symbol rate for test channel is shown in Table 6.1.

Table 6.1: Bit / Symbol rate for Test Channel

Type of User Information	User bit rate	DL DPCH symbol rate	UL DPCH bit rate	Remarks
12.2 kbps reference measurement channel	12.2 kbps	30 ksps	60 kbps	Standard Test

Unless otherwise stated the receiver characteristics are specified at the antenna connector of the UE. For UE(s) with an integral antenna only, a reference antenna with a gain of 0 dBi is assumed. UE with an integral antenna may be taken into account by converting these power levels into field strength requirements, assuming a 0 dBi gain antenna. Receiver characteristics for UE(s) with multiple antennas/antenna connectors are FFS.

The UE antenna performance has a significant impact on system performance, and minimum requirements on the antenna efficiency are therefore intended to be included in future versions of this specification. It is recognised that different requirements and test methods are likely to be required for the different types of UE.

All the parameters in clause 6 are defined using the DL reference measurement channel (12.2 kbps) specified in subclause C.3.1 and unless stated otherwise, with DL power control OFF.

The common RF test conditions of Rx Characteristics are defined in Annex E.3.2, and each test conditions in this clause (clause 6) should refer Annex E.3.2. Individual test conditions are defined in the paragraph of each test.

6.2 Reference Sensitivity Level

6.2.1 Definition and applicability

The reference sensitivity is the minimum receiver input power measured at the antenna port at which the Bit Error Ratio (BER) does not exceed a specific value

The requirements and this test apply to all types of UTRA for the FDD UE.

6.2.2 Minimum Requirements

The BER shall not exceed 0.001 for the parameters specified in Table 6.2.1.

Table 6.2.1: Test parameters for Reference Sensitivity Level

Parameter	Level / Status	Unit
\hat{I}_{or}	-106.7	dBm / 3.84 MHz
DPCH_Ec	-117	dBm / 3.84 MHz

The normative reference for this requirement is [1] TS 25.101 subclause 7.3.1.

6.2.3 Test purpose

To verify that the UE BER does not exceed 0.001 for the parameters specified in Table 6.2.

The lack of the reception sensitivity decreases the coverage area at the far side from Node B.

6.2.4 Method of test

6.2.4.1 ~~6.2.4.1~~ Initial conditions

Test environment: normal, TL/VL, TL/VH, TH/VL, TH/VH; see subclauses G.2.1 and G.2.2.

Frequencies to be tested: low range, mid range, high range; see subclause G.2.4.

- 1) Connect the SS to the UE antenna connector as shown in Figure A.3.
- 2) A call is set up according to the Generic call setup procedure, and RF parameters are set up according to Table 6.2.2.
- 3) Enter the UE into loopback test mode and start the loopback test.

See [3] TS 34.108 and [4] TS 34.109 for details regarding generic call setup procedure and loopback test.

6.2.4.2 Procedure

- 1) Set and send continuously Up power control commands to the UE until the UE output power shall be maximum level.
- 2) Measure the BER of DCH received from the UE at the SS.

6.2.5 Test requirements

The measured BER, derived in step 2), shall not exceed 0.001.

Table 6.2.2: Test parameters for Reference Sensitivity Level

Parameter	Level / Status	Unit
\hat{I}_{or}	-106	dBm / 3.84 MHz
DPCH_Ec	-116.3	dBm / 3.84 MHz

NOTE: If the above Test Requirement differs from the Minimum Requirement then the Test Tolerance applied for this test is non-zero. The Test Tolerance for this test is defined in Annex F.2 and the explanation of how the Minimum Requirement has been relaxed by the Test Tolerance is given in Annex F.4.

6.3 Maximum Input Level

6.3.1 Definition and applicability

This is defined as the maximum receiver input power at the UE antenna port which does not degrade the specified BER performance.

The requirements and this test apply to all types of UTRA for the FDD UE.

6.3.2 Conformance requirements

The BER shall not exceed 0.001 for the parameters specified in Table 6.3.

The reference for this requirement is [1] TS 25.101 subclause 7.4.1.

NOTE: Since the spreading factor is large ($10\log(SF)=21\text{dB}$), the majority of the total input signal consists of the OCNS interference. The structure of OCNS signal is defined in Annex E.3.2.

6.3.3 Test purpose

To verify that the UE BER does not exceed 0.001 for the parameters specified in Table 6.3.

The lack of the maximum input level decreases the coverage area at the near side from Node B.

6.3.4 Method of test

6.3.4.1 ~~6.3.4.1~~—Initial conditions

Test environment: normal; see subclauses G.2.1 and G.2.2.

Frequencies to be tested: mid range; see subclause G.2.4.

- 1) Connect the SS to the UE antenna connector as shown in Figure A.3.
- 2) A call is set up according to the Generic call setup procedure, and RF parameters are set up according to Table 6.3 and Table E.3.3.
- 3) Enter the UE into loopback test mode and start the loopback test.

See [3] TS 34.108 and [4] TS 34.109 for details regarding generic call setup procedure and loopback test.

Table 6.3: Test parameters for Maximum Input Level

Parameter	Level / Status	Unit
I_{or}	-25	dBm / 3.84MHz
$\frac{DPCH_E_c}{I_{or}}$	-19	dB

6.3.4.2 Procedure

- 1) Measure the BER of DCH received from the UE at the SS.

6.3.5 Test requirements

The measured BER, derived in step 1), shall not exceed 0.001.

6.4 Adjacent Channel Selectivity (ACS)

6.4.1 Definition and applicability

Adjacent Channel Selectivity (ACS) is a measure of a receiver's ability to receive a W-CDMA signal at its assigned channel frequency in the presence of an adjacent channel signal at a given frequency offset from the centre frequency of the assigned channel. ACS is the ratio of the receive filter attenuation on the assigned channel frequency to the receive filter attenuation on the adjacent channel(s).

The requirements and this test apply to all types of UTRA for the FDD UE.

6.4.2 Minimum Requirements

For the UE of power class 3 and 4, the BER shall not exceed 0.001 for the parameters specified in Table 6.4.1. This test condition is equivalent to the ACS value 33 dB.

Table 6.4.1: Test parameters for Adjacent Channel Selectivity

Parameter	Level / Status	Unit
DPCH_Ec	-103	dBm / 3.84 MHz
I _{or}	-92.7	dBm / 3.84 MHz
I _{oac} (modulated)	-52	dBm / 3.84 MHz
F _{uw} (offset)	-5 or +5	MHz

The normative reference for this requirement is [1] TS 25.101 subclause 7.5.1.

Note: The I_{oac} (modulated) signal consists of common channels needed for tests and 16 dedicated data channels. The channelisation codes for data channels are chosen optimally to reduce peak to average ratio (PAR). All dedicated channels user data is uncorrelated to each other.

6.4.3 Test purpose

To verify that the UE BER does not exceed 0.001 for the test parameters specified in Table 6.4.1.

The lack of the ACS decreases the coverage area when other transmitter exists in the adjacent channel.

6.4.4 Method of test

6.4.4.1 ~~6.4.4.1~~—Initial conditions

Test environment: normal; see subclauses G.2.1 and G.2.2.

Frequencies to be tested: mid range; see subclause G.2.4.

- 1) Connect the SS to the UE antenna connector as shown in Figure A.4.
- 2) A call is set up according to the Generic call setup procedure, and RF parameters are set up according to Table 6.4.2.
- 3) Enter the UE into loopback test mode and start the loopback test.

See [3] TS 34.108 and [4] TS 34.109 for details regarding generic call setup procedure and loopback test.

6.4.4.2 Procedure

- 1) Set the parameters of the interference signal generator as shown in Table 6.4.2.
- 2) Measure the BER of DCH received from the UE at the SS.

6.4.5 Test requirements

The measured BER, derived in step 1), shall not exceed 0.001.

Table 6.4.2: Test parameters for Adjacent Channel Selectivity

Parameter	Level / Status	Unit
DPCH_Ec	-103	dBm / 3.84 MHz
I_{or}	-92.7	dBm / 3.84 MHz
I_{oac} (modulated)	-52	dBm / 3.84 MHz
F_{uw} (offset)	-5 or +5	MHz

NOTE: If the above Test Requirement differs from the Minimum Requirement then the Test Tolerance applied for this test is non-zero. The Test Tolerance for this test is defined in Annex F.2 and the explanation of how the Minimum Requirement has been relaxed by the Test Tolerance is given in Annex F.4.

6.5 Blocking Characteristics

6.5.1 Definition and applicability

The blocking characteristic is a measure of the receiver's ability to receive a wanted signal at its assigned channel frequency in the presence of an unwanted interferer on frequencies other than those of the spurious response or the adjacent channels, without this unwanted input signal causing a degradation of the performance of the receiver beyond a specified limit. The blocking performance shall apply at all frequencies except those at which a spurious response occur.

The requirements and this test apply to all types of UTRA for the FDD UE.

6.5.2 Minimum Requirements

The BER shall not exceed 0.001 for the parameters specified in Table 6.5.1 and Table 6.5.2. For Table 6.5.2 up to (24) exceptions are allowed for spurious response frequencies in each assigned frequency channel when measured using a 1 MHz step size.

The normative reference for this requirement is [1] TS 25.101 subclause 7.6.1.

Note: $I_{blocking}$ (modulated) consists of common channels and 16 dedicated data channels. The channelisation codes for data channels are chosen optimally to reduce peak to average ratio (PAR). All dedicated channels user data is uncorrelated to each other.

Table 6.5.1: Test parameters for In-band blocking characteristics

Parameter	10 MHz offset	15 MHz offset	Unit
DPCH_Ec	-114	-114	dBm / 3.84 MHz
I_{or}	-103.7	-103.7	dBm / 3.84 MHz
$I_{blocking}$ (modulated)	-56	-44	dBm / 3.84 MHz
F_{uw} (offset)	+10 or -10	+15 or -15	MHz

Table 6.5.2: Test parameters for Out of band blocking characteristics

Parameter	Band 1	Band 2	Band 3	Unit
DPCH_Ec	-114	-114	-114	dBm / 3.84MHz
\uparrow or	-103.7	-103.7	-103.7	dBm / 3.84MHz
I _{blocking} (CW)	-44	-30	-15	dBm
F _{uw} For operation in frequency bands as defined in subclause 4.2(a)	2050 < f < 2095 2185 < f < 2230	2025 < f < 2050 2230 < f < 2255	1 < f < 2025 2255 < f < 12750	MHz
F _{uw} For operation in frequency bands as defined in subclause 4.2(b)	1870 < f < 1915 2005 < f < 2050	1845 < f < 1870 2050 < f < 2075	1 < f < 1845 2075 < f < 12750	MHz

NOTE:

1. For operation in bands referenced in 4.2(a), from 2095 < f < 2110 MHz and 2170 < f < 2185 MHz, the appropriate in-band blocking or adjacent channel selectivity in subclause 6.4.2 shall be applied.
2. For operation in bands referenced in 4.2(b), 1915 < f < 1930 MHz and 1990 < f < 2005 MHz, the appropriate in-band blocking or adjacent channel selectivity in subclause 6.4.2 shall be applied.

6.5.3 Test purpose

To verify that the UE BER does not exceed 0.001 for the parameters specified in Table 6.5.1 and Table 6.5.2. For Table 6.5.2 up to (24) exceptions are allowed for spurious response frequencies in each assigned frequency channel when measured using a 1 MHz step size.

The lack of the blocking ability decreases the coverage area when other transmitter exists (except in the adjacent channels and spurious response).

6.5.4 Method of test

6.5.4.1 ~~6.5.4.1~~ Initial conditions

For in-band case:

Test environment: normal; see subclauses G.2.1 and G.2.2.

Frequencies to be tested: mid range; see subclause G.2.4.

For out-of-band case:

Test environment: normal; see subclauses G.2.1 and G.2.2.

Frequencies to be tested: 1 arbitrary frequency selected between low and high range; see subclause G.2.4.

- 1) Connect the SS to the UE antenna connector as shown in Figure A.5.
- 2) A call is set up according to the Generic call setup procedure, and RF parameters are set up according to Table 6.5.3 and Table 6.5.4.
- 3) Enter the UE into loopback test mode and start the loopback test.

See [3] TS 34.108 and [4] TS 34.109 for details regarding generic call setup procedure and loopback test.

6.5.4.2 Procedure

- 1) Set the parameters of the CW generator or the interference signal generator as shown in Table 6.5.3 and Table 6.5.4. For Table 6.5.4, the frequency step size is 1 MHz.
- 2) Measure the BER of DCH received from the UE at the SS.
- 3) For Table 6.5.4, record the frequencies for which BER exceed the test requirements.

6.5.5 Test requirements

For Table 6.5.3, the measured BER, derived in step 2), shall not exceed 0.001. For Table 6.5.4, the measured BER, derived in step 2) shall not exceed 0.001 except for the spurious response frequencies, recorded in step 3). The number of spurious response frequencies, recorded in step 3) shall not exceed 24.

Table 6.5.3: Test parameters for In-band blocking characteristics

Parameter	10 MHz offset	15 MHz offset	Unit
DPCH_Ec	-114	-114	dBm / 3.84 MHz
I _{or}	-103.7	-103.7	dBm / 3.84 MHz
I _{blocking} (modulated)	-56	-44	dBm / 3.84 MHz
F _{uw} (offset)	+10 or -10	+15 or -15	MHz

Table 6.5.4: Test parameters for Out of band blocking characteristics

Parameter	Band 1	Band 2	Band 3	Unit
DPCH_Ec	-114	-114	-114	dBm / 3.84MHz
I _{or}	-103.7	-103.7	-103.7	dBm / 3.84MHz
I _{blocking} (CW)	-44	-30	-15	dBm
F _{uw} For operation in frequency bands as defined in subclause 4.2(a)	2050 < f < 2095 2185 < f < 2230	2025 < f < 2050 2230 < f < 2255	1 < f < 2025 2255 < f < 12750	MHz
F _{uw} For operation in frequency bands as defined in subclause 4.2(b)	1870 < f < 1915 2005 < f < 2050	1845 < f < 1870 2050 < f < 2075	1 < f < 1845 2075 < f < 12750	MHz

NOTE:

1. For operation in bands referenced in 4.2(a), from 2095 < f < 2110 MHz and 2170 < f < 2185 MHz, the appropriate in-band blocking or adjacent channel selectivity in subclause 6.4.2 shall be applied.
2. For operation in bands referenced in 4.2(b), 1915 < f < 1930 MHz and 1990 < f < 2005 MHz, the appropriate in-band blocking or adjacent channel selectivity in subclause 6.4.2 shall be applied.
3. If the above Test Requirement differs from the Minimum Requirement then the Test Tolerance applied for this test is non-zero. The Test Tolerance for this test is defined in Annex F.2 and the explanation of how the Minimum Requirement has been relaxed by the Test Tolerance is given in Annex F.4.

6.6 Spurious Response

6.6.1 Definition and applicability

Spurious response is a measure of the receiver's ability to receive a wanted signal on its assigned channel frequency without exceeding a given degradation due to the presence of an unwanted CW interfering signal at any other frequency at which a response is obtained i.e. for which the blocking limit is not met.

The requirements and this test apply to all types of UTRA for the FDD UE.

6.6.2 Minimum Requirements

The BER shall not exceed 0.001 for the parameters specified in Table 6.6.1.

The normative reference for this requirement is [1] TS 25.101 subclause 7.7.1.

Table 6.6.1: Test parameters for Spurious Response

Parameter	Level	Unit
DPCH_Ec	-114	dBm / 3.84MHz
\hat{I}_{or}	-103.7	dBm / 3.84MHz
$I_{blocking}(CW)$	-44	dBm
F_{uw}	Spurious response frequencies	MHz

6.6.3 Test purpose

To verify that the UE BER does not exceed 0.001 for the parameters specified in Table 6.6.1.

The lack of the spurious response ability decreases the coverage area when other unwanted interfering signal exists at any other frequency.

6.6.4 Method of test

6.6.4.1 ~~6.6.4.1~~ Initial conditions

Test environment: normal; see subclauses G.2.1 and G.2.2.

Frequencies to be tested: low range, high range; see subclause G.2.4.

- 1) Connect the SS to the UE antenna connector as shown in Figure A.6.
- 2) A call is set up according to the Generic call setup procedure, and RF parameters are set up according to Table 6.6.2.
- 3) Enter the UE into loopback test mode and start the loopback test.

See [3] TS 34.108 and [4] TS 34.109 for details regarding generic call setup procedure and loopback test.

6.6.4.2 Procedure

- 1) Set the parameter of the CW generator as shown in Table 6.6.2. The spurious response frequencies are determined in step 3) of section 6.5.4.2.
- 2) Measure the BER of DCH received from the UE at the SS.

6.6.5 Test requirements

The measured BER, derived in step 2), shall not exceed 0.001.

Table 6.6.2: Test parameters for Spurious Response

Parameter	Level	Unit
DPCH_Ec	-114	dBm / 3.84MHz
I_{or}	-103.7	dBm / 3.84MHz
$I_{blocking}(CW)$	-44	dBm
F_{UW}	Spurious response frequencies	MHz

NOTE: If the above Test Requirement differs from the Minimum Requirement then the Test Tolerance applied for this test is non-zero. The Test Tolerance for this test is defined in Annex F.2 and the explanation of how the Minimum Requirement has been relaxed by the Test Tolerance is given in Annex F.4.

6.7 Intermodulation Characteristics

6.7.1 Definition and applicability

Third and higher order mixing of the two interfering RF signals can produce an interfering signal in the band of the desired channel. Intermodulation response rejection is a measure of the capability of the receiver to receiver a wanted signal on its assigned channel frequency in the presence of two or more interfering signals which have a specific frequency relationship to the wanted signal.

The requirements and this test apply to all types of UTRA for the FDD UE.

6.7.2 Minimum Requirements

The BER shall not exceed 0.001 for the parameters specified in Table 6.7.1.

The normative reference for this requirement is [1] TS 25.101 subclause 7.8.1.

Note: I_{ouw2} (modulated) consists of common channels and 16 dedicated data channels. The channelisation codes for data channels are chosen optimally to reduce peak to average ratio (PAR). All dedicated channels user data is uncorrelated to each other.

Table 6.7.1: Test parameters for Intermodulation Characteristics

Parameter	Level		Unit
DPCH_Ec	-114		dBm / 3.84 MHz
I_{or}	-103.7		dBm / 3.84 MHz
I_{ouw1} (CW)	-46		dBm
I_{ouw2} (modulated)	-46		dBm / 3.84 MHz
F_{UW1} (offset)	10	-10	MHz
F_{UW2} (offset)	20	-20	MHz

6.7.3 Test purpose

To verify that the UE BER does not exceed 0.001 for the parameters specified in Table 6.7.1.

The lack of the intermodulation response rejection ability decreases the coverage area when two or more interfering signals, which have a specific frequency relationship to the wanted signal, exist.

6.7.4 Method of test

[6.7.4.1](#) ~~6.7.4.1~~—Initial conditions

Test environment: normal; see subclauses G.2.1 and G.2.2.

Frequencies to be tested: mid range; see subclause G.2.4.

- 1) Connect the SS to the UE antenna connector as shown in Figure A.7.
- 2) A call is set up according to the Generic call setup procedure, and RF parameters are set up according to Table 6.7.2.
- 3) Enter the UE into loopback test mode and start the loopback test.

See [3] TS 34.108 and [4] TS 34.109 for details regarding generic call setup procedure and loopback test.

6.7.4.2 Procedure

- 1) Set the parameters of the CW generator and interference signal generator as shown in Table 6.7.2.
- 2) Measure the BER of DCH received from the UE at the SS.

6.7.5 Test requirements

The measured BER, derived in step 1), shall not exceed 0.001.

Table 6.7.2: Test parameters for Intermodulation Characteristics

Parameter	Level		Unit
DPCH_Ec	-114		dBm / 3.84 MHz
I _{or}	-103.7		dBm / 3.84 MHz
I _{ouw1} (CW)	-46		dBm
I _{ouw2} (modulated)	-46		dBm / 3.84 MHz
F _{uw1} (offset)	10	-10	MHz
F _{uw2} (offset)	20	-20	MHz

NOTE: If the above Test Requirement differs from the Minimum Requirement then the Test Tolerance applied for this test is non-zero. The Test Tolerance for this test is defined in Annex F.2 and the explanation of how the Minimum Requirement has been relaxed by the Test Tolerance is given in Annex F.4.

6.8 Spurious Emissions

6.8.1 Definition and applicability

The spurious emissions power is the power of emissions generated or amplified in a receiver that appear at the UE antenna connector.

The requirements and this test apply to all types of UTRA for the FDD UE.

6.8.2 Minimum Requirements

The power of any narrow band CW spurious emission shall not exceed the maximum level specified in Table 6.8.1 and Table 6.8.2.

Table 6.8.1: General receiver spurious emission requirements

Frequency Band	Measurement Bandwidth	Maximum level	Note
9kHz ≤ f < 1GHz	100 kHz	-57 dBm	
1GHz ≤ f ≤ 12.75 GHz	1 MHz	-47 dBm	

Table 6.8.2: Additional receiver spurious emission requirements

Frequency Band	Measurement Bandwidth	Maximum level	Note
$1920 \text{ MHz} \leq f \leq 1980 \text{ MHz}$	3.84 MHz	-60 dBm	Mobile transmit band in URA_PCH, Cell_PCH and idle state
$2110 \text{ MHz} \leq f \leq 2170 \text{ MHz}$	3.84 MHz	-60 dBm	Mobile receive band

The reference for this requirement is [1] TS 25.101 subclause 7.9.1.

6.8.3 Test purpose

To verify that the UE spurious emission meets the specifications described in subclause 6.8.2.

Excess spurious emissions increase the interference to other systems.

6.8.4 Method of test

6.8.4.1 ~~6.8.4.1~~ Initial conditions

Test environment: normal; see subclauses G.2.1 and G.2.2.

Frequencies to be tested: low range, mid range, high range; see subclause G.2.4.

- 1) Connect a spectrum analyzer (or other suitable test equipment) to the UE antenna connector as shown in Figure A.8.
- 2) RF parameters are setup according to Table [TBD].
- 3) UE shall be camped on a cell
- 4) UE shall perform Location Registration (LR) before the test procedure in subclause 6.8.4.2, but not during it.
- 5) Neighbour cell list shall be empty.
- 6) Paging repetition period and DRX cycle shall be set to minimum (shortest possible time interval).

6.8.4.2 Procedure

- 1) Sweep the spectrum analyzer (or equivalent equipment) over a frequency range and measure the average power of spurious emission.

6.8.5 Test requirements

The all measured spurious emissions, derived in step 1), shall not exceed the maximum level specified in Table 6.8.3 and Table 6.8.4.

Table 6.8.3: General receiver spurious emission requirements

Frequency Band	Measurement Bandwidth	Maximum level	Note
$9\text{kHz} \leq f < 1\text{GHz}$	100 kHz	-57 dBm	
$1\text{GHz} \leq f \leq 12.75 \text{ GHz}$	1 MHz	-47 dBm	

Table 6.8.4: Additional receiver spurious emission requirements

Frequency Band	Measurement Bandwidth	Maximum level	Note
$1920 \text{ MHz} \leq f \leq 1980 \text{ MHz}$	3.84 MHz	-60 dBm	Mobile transmit band in URA_PCH, Cell_PCH and idle state
$2110 \text{ MHz} \leq f \leq 2170 \text{ MHz}$	3.84 MHz	-60 dBm	Mobile receive band

NOTE: If the above Test Requirement differs from the Minimum Requirement then the Test Tolerance applied for this test is non-zero. The Test Tolerance for this test is defined in Annex F.2 and the explanation of how the Minimum Requirement has been relaxed by the Test Tolerance is given in Annex F.4.

7 Performance requirements

7.1 General

The performance requirements for the UE in this clause are specified for the measurement channels specified in Annex C and Table 7.1.1, the propagation conditions specified in 7.1.2 and the Down link Physical channels specified in Annex D. Unless stated otherwise, DL power control is OFF.

The method for Block Error Ratio (BLER) measurement is specified in [4] TS 34.109.

Table 7.1.1: Bit / Symbol rate for Test Channel

Type of User Information	User bit rate	DL DPCH symbol rate	UL DPCH bit rate
12.2 kbps reference measurement channel	12.2 kbps	30 ksps	60 kbps
64/144/384 kbps reference measurement channel	64 kbps	120 ksps	240 kbps
	144 kbps	240 ksps	480 kbps
	384 kbps	480 ksps	960 kbps

The common RF test conditions of Performance requirement are defined in Annex E.3.3, and each test conditions in this clause (clause 7) should refer Annex E.3.3. Individual test conditions are defined in the paragraph of each test.

7.1.1 Measurement Configurations

In all measurements UE should transmit with maximum power while receiving signals from Node B. Transmission Power Control is always disable during the measurements. Chip Rate is specified to be 3.84 MHz.

It is assumed that fields inside DPCH have the same energy per PN chip. Also, if the power of S-CCPCH is not specified in the test parameter table, it should be set to zero. The power of OCNS should be adjusted that the power ratios (E_c/I_{or}) of all specified forward channels add up to one.

Measurement configurations for different scenarios are shown in Figure A.9, Figure A.10 and Figure A.11.

7.2 Demodulation in Static Propagation conditions

7.2.1 Demodulation of Dedicated Channel (DCH)

7.2.1.1 Definition and applicability

The receive characteristic of the Dedicated Channel (DCH) in the static environment is determined by the Block Error Ratio (BLER). BLER is specified for each individual data rate of the DCH. DCH is mapped into the Dedicated Physical Channel (DPCH).

The UE shall be tested only according to the data rate, supported. The data-rate-corresponding requirements shall apply to the UE.

7.2.1.2 Conformance requirements

For the parameters specified in Table 7.2.1.1 the average downlink $\frac{DPCH - E_c}{I_{or}}$ power shall be below the specified value for the BLER shown in Table 7.2.1.2. These requirements are applicable for TFCS size 16.

Table 7.2.1.1: DCH parameters in static propagation conditions

Parameter	Test 1	Test 2	Test 3	Test 4	Unit
Phase reference	P-CPICH				
\hat{I}_{or}/I_{oc}	-1				dB
I_{oc}	-60				dBm / 3.84 MHz
Information Data Rate	12,2	64	144	384	kbps

Table 7.2.1.2: DCH requirements in static propagation conditions

Test Number	$\frac{DPCH - E_c}{I_{or}}$	BLER
1	-16.6 dB	10^{-2}
2	-13.1 dB	10^{-1}
	-12.8 dB	10^{-2}
3	-9.9 dB	10^{-1}
	-9.8 dB	10^{-2}
4	-5.6 dB	10^{-1}
	-5.5 dB	10^{-2}

The reference for this requirement is [1] TS 25.101 subclause 8.2.3.1.

7.2.1.3 Test purpose

To verify the ability of the receiver to receive a predefined test signal, representing a static propagation channel for the wanted and for the co-channel signals from serving and adjacent cells, with a BLER not exceeding a specified value.

7.2.1.4 Method of test

7.2.1.4.1 ~~7.2.1.4.1~~ Initial conditions

Test environment: normal; see subclauses G.2.1 and G.2.2.

Frequencies to be tested: mid range; see subclause G.2.4.

1. Connect the SS and an AWGN noise source to the UE antenna connector as shown in Figure A.9.

2. Set up a call according to the Generic call setup procedure.
3. Set the test parameters for test 1-5 as specified in Table 7.2.1.1.
4. Enter the UE into loopback test mode and start the loopback test.

7.2.1.4.2 Procedures

1. Measure BLER of DCH.

7.2.1.5 Test requirements

For the parameters specified in Table 7.2.1.1 the BLER shall not exceed the value at the $DPCH_{Ec}/I_{or}$ specified in Table 7.2.1.2.

7.3 Demodulation of DCH in Multi-path Fading Propagation conditions

7.3.1 Single Link Performance

7.3.1.1 Definition and applicability

The receive characteristics of the Dedicated Channel (DCH) in different multi-path fading environments are determined by the Block Error Ratio (BLER) values. BLER is measured for the each of the individual data rate specified for the DPCH. DCH is mapped into in Dedicated Physical Channel (DPCH).

The UE shall be tested only according to the data rate, supported. The data-rate-corresponding requirements shall apply to the UE.

7.3.1.2 Conformance requirements

For the parameters specified in Table 7.3.1.1, 7.3.1.3, 7.1.3.5 and 7.1.3.7 the average downlink $\frac{DPCH_{Ec}}{I_{or}}$ power shall be below the specified value for the BLER shown in Table 7.3.1.2, 7.3.1.4, 7.3.1.6 and 7.3.1.8. These requirements are applicable for TFCS size 16.

Table 7.3.1.1: DCH parameters in multi-path fading propagation conditions (Case 1)

Parameter	Test 1	Test 2	Test 3	Test 4	Unit
Phase reference	P-CPICH				
\hat{I}_{or}/I_{oc}	9				dB
I_{oc}	-60				dBm / 3.84 MHz
Information Data Rate	12.2	64	144	384	kbps

Table 7.3.1.2: DCH requirements in multi-path fading propagation conditions (Case 1)

Test Number	$\frac{DPCH_E_c}{I_{or}}$	BLER
1	-15.0 dB	10^{-2}
2	-13.9 dB	10^{-1}
	-10.0 dB	10^{-2}
3	-10.6 dB	10^{-1}
	-6.8 dB	10^{-2}
4	-6.3 dB	10^{-1}
	-2.2 dB	10^{-2}

Table 7.3.1.3: DCH parameters in multi-path fading propagation conditions (Case 2)

Parameter	Test 5	Test 6	Test 7	Test 8	Unit
Phase reference	P-CPICH				
\hat{I}_{or}/I_{oc}	-3	-3	3	6	dB
I_{oc}	-60				dBm / 3.84 MHz
Information Data Rate	12.2	64	144	384	kbps

Table 7.3.1.4: DCH requirements in multi-path fading propagation conditions (Case 2)

Test Number	$\frac{DPCH_E_c}{I_{or}}$	BLER
5	-7.7 dB	10^{-2}
6	-6.4 dB	10^{-1}
	-2.7 dB	10^{-2}
7	-8.1 dB	10^{-1}
	-5.1 dB	10^{-2}
8	-5.5 dB	10^{-1}
	-3.2 dB	10^{-2}

Table 7.3.1.5: DCH parameters in multi-path fading propagation conditions (Case 3)

Parameter	Test 9	Test 10	Test 11	Test 12	Unit
Phase reference	P-CPICH				
\hat{I}_{or}/I_{oc}	-3	-3	3	6	dB
I_{oc}	-60				dBm / 3.84 MHz
Information Data Rate	12.2	64	144	384	kbps

Table 7.3.1.6: DCH requirements in multi-path fading propagation conditions (Case 3)

Test Number	$\frac{DPCH_E_c}{I_{or}}$	BLER
9	-11.8 dB	10^{-2}
10	-8.1 dB	10^{-1}
	-7.4 dB	10^{-2}
	-6.8 dB	10^{-3}
11	-9.0 dB	10^{-1}
	-8.5 dB	10^{-2}
	-8.0 dB	10^{-3}
12	-5.9 dB	10^{-1}
	-5.1 dB	10^{-2}
	-4.4 dB	10^{-3}

Table 7.3.1.7: DCH parameters in multi-path fading propagation conditions (Case 1) with S-CPICH

Parameter	Test 13	Test 14	Test 15	Test 16	Unit
Phase reference	S-CPICH				
\hat{I}_{or}/I_{oc}	9				dB
I_{oc}	-60				dBm / 3.84 MHz
Information Data Rate	12.2	64	144	384	kbps

Table 7.3.1.8: DCH requirements in multi-path fading propagation conditions (Case 1) with S-CPICH

Test Number	$\frac{DPCH_E_c}{I_{or}}$	BLER
13	-15.0 dB	10^{-2}
14	-13.9 dB	10^{-1}
	-10.0 dB	10^{-2}
15	-10.6 dB	10^{-1}
	-6.8 dB	10^{-2}
16	-6.3 dB	10^{-1}
	-2.2 dB	10^{-2}

The reference for this requirement is [1] TS 25.101 subclause 8.3.1.1.

7.3.1.3 Test purpose

To verify the ability of the receiver to receive a predefined test signal, representing a multi-path fading propagation channel for the wanted and for the co-channel signals from serving and adjacent cells, with a BLER not exceeding a specified value.

7.3.1.4 Method of test

7.3.1.4.1 ~~7.3.1.4.1~~ Initial conditions

Test environment: normal; see subclauses G.2.1 and G.2.2.

Frequencies to be tested: mid range; see subclause G.2.4.

1. Connect the SS, multi-path fading simulator and an AWGN noise source to the UE antenna connector as shown in Figure A.10.
2. Set up a call according to the Generic call setup procedure.
3. Set the test parameters for test 1-15 as specified Table 7.3.1.1, Table 7.3.1.3, Table 7.3.1.5 and Table 7.3.1.7.
4. Enter the UE into loopback test mode and start the loopback test.
5. Setup fading simulators as fading condition case 1 to 3 which are described in Table D.2.2.1

7.3.1.4.2 Procedures

1. Measure BLER of DCH.

7.3.1.5 Test requirements

For the parameters specified in Table 7.3.1.1, Table 7.3.1.3, Table 7.3.1.5 and Table 7.3.1.7 the BLER shall not exceed the value at the $DPCH_E_c/I_{or}$ specified in Table 7.3.1.2, Table 7.3.1.4, Table 7.3.1.6 and Table 7.3.1.8.

7.4 Demodulation of DCH in Moving Propagation conditions

7.4.1 Single Link Performance

7.4.1.1 Definition and applicability

The receive single link performance of the Dedicated Channel (DCH) in dynamic moving propagation conditions are determined by the Block Error Ratio (BLER) values. BLER is measured for the each of the individual data rate specified for the DPCH. DCH is mapped into Dedicated Physical Channel (DPCH).

The UE shall be tested only according to the data rate, supported. The data-rate-corresponding requirements shall apply to the UE.

7.4.1.2 Conformance requirements

For the parameters specified in Table 7.4.1.1 the average downlink $\frac{DPCH_E_c}{I_{or}}$ power shall be below the specified value for the BLER shown in Table 7.4.1.2.

Table 7.4.1.1: DCH parameters in moving propagation conditions

Parameter	Test 1	Test 2	Unit
Phase reference	P-CPICH		
\hat{I}_{or}/I_{oc}	-1		dB
I_{oc}	-60		dBm / 3.84 MHz
Information Data Rate	12.2	64	kbps

Table 7.4.1.2: DCH requirements in moving propagation conditions

Test Number	$\frac{DPCH_E_c}{I_{or}}$	BLER
1	-14.5 dB	10^{-2}
2	-10.9 dB	10^{-2}

The reference for this requirement is [1] TS 25.101 subclause 8.4.1.1.

7.4.1.3 Test purpose

To verify the ability of the receiver to receive a predefined test signal, representing a moving propagation channel for the wanted and for the co-channel signals from serving and adjacent cells, with a BLER not exceeding a specified value.

7.4.1.4 Method of test

7.4.1.4.1 ~~7.4.1.4.1~~ Initial conditions

Test environment: normal; see subclauses G.2.1 and G.2.2.

Frequencies to be tested: mid range; see subclause G.2.4.

1. Connect the SS and an AWGN noise source to the UE antenna connector as shown in Figure A.10.
2. Set up a call according to the Generic call setup procedure.
3. Set the test parameters as specified in Table 7.4.1.1.
4. Enter the UE into loopback test mode and start the loopback test.
5. Setup fading simulator as moving propagation condition, which is described in clause D.2.3.

7.4.1.4.2 Procedures

1. Measure BLER of DCH.

7.4.1.5 Test requirements

For the parameters specified in Table 7.4.1.1 the BLER shall not exceed the value at the $DPCH_{Ec}/I_{or}$ specified in Table 7.4.1.2.

7.5 Demodulation of DCH in Birth-Death Propagation conditions

7.5.1 Single Link Performance

7.5.1.1 Definition and applicability

The receive single link performance of the Dedicated Channel (DCH) in dynamic birth-death propagation conditions are determined by the Block Error Ratio (BLER) values. BLER is measured for the each of the individual data rate specified for the DPCH. DCH is mapped into Dedicated Physical Channel (DPCH).

The UE shall be tested only according to the data rate, supported. The data-rate-corresponding requirements shall apply to the UE.

7.5.1.2 Conformance requirements

For the parameters specified in Table 7.5.1.1 the average downlink $\frac{DPCH_{Ec}}{I_{or}}$ power shall be below the specified value for the BLER shown in Table 7.5.1.2.

Table 7.5.1.1: DCH parameters in birth-death propagation conditions

Parameter	Test 1	Test 2	Unit
Phase reference	P-CPICH		
\hat{I}_{or}/I_{oc}	-1		dB
I_{oc}	-60		dBm / 3.84 MHz
Information Data Rate	12.2	64	kbps

Table 7.5.1.2: DCH requirements in birth-death propagation conditions

Test Number	$\frac{DPCH_E_c}{I_{or}}$	BLER
1	-12.6 dB	10^{-2}
2	-8.7 dB	10^{-2}

The reference for this requirement is [1] TS 25.101 subclause 8.5.1.1.

7.5.1.3 Test purpose

To verify the ability of the receiver to receive a predefined test signal, representing a birth-death propagation channel for the wanted and for the co-channel signals from serving and adjacent cells, with a BLER not exceeding a specified value.

7.5.1.4 Method of test

7.5.1.4.1 ~~7.5.1.4.1~~ Initial conditions

Test environment: normal; see subclauses G.2.1 and G.2.2.

Frequencies to be tested: mid range; see subclause G.2.4.

1. Connect the SS and an AWGN noise source to the UE antenna connector as shown in Figure A.10.
2. Set up a call according to the Generic call setup procedure.
3. Set the test parameters as specified in Table 7.5.1.1.
4. Enter the UE into loopback test mode and start the loopback test.
5. Setup fading simulator as birth-death propagation condition, which is described in clause D.2.4.

7.5.1.4.2 Procedures

1. Measure BLER of DCH.

7.5.1.5 Test requirements

For the parameters specified in Table 7.5.1.1 the BLER shall not exceed the value at the $DPCH_E_c/I_{or}$ specified in Table 7.5.1.2.

7.6 Demodulation of DCH in Base Station Transmit diversity modes

7.6.1 Demodulation of DCH in open-loop transmit diversity mode

7.6.1.1 Definition and applicability

The receive characteristic of the Dedicated Channel (DCH) in open loop transmit diversity mode is determined by the Block Error Ratio (BLER). DCH is mapped into in Dedicated Physical Channel (DPCH).

The requirements and this test apply to all types of UTRA for the FDD UE.

7.6.1.2 Conformance requirements

For the parameters specified in Table 7.6.1.1 the average downlink $\frac{DPCH_E_c}{I_{or}}$ power shall be below the specified value for the BLER shown in Table 7.6.1.2.

Table 7.6.1.1: Test parameters for DCH reception in an open-loop transmit diversity scheme (Propagation condition: Case 1)

Parameter	Test 1	Unit
Phase reference	P-CPICH	
\hat{I}_{or}/I_{oc}	9	dB
I_{oc}	-60	dBm / 3.84 MHz
Information data rate	12.2	kbps

Table 7.6.1.2: Test requirements for DCH reception in open-loop transmit diversity scheme

Test Number	$\frac{DPCH_E_c}{I_{or}}$ (antenna 1/2)	BLER
1	[-16.8 dB]	10^{-2}

The reference for this requirement is [1] TS 25.101 subclause 8.6.1.1.

7.6.1.3 Test purpose

To verify that UE reliably demodulates the DPCH of the Node B while open loop transmit diversity is enabled during the connection.

7.6.1.4 Method of test

7.6.1.4.1 ~~7.6.1.4.1~~ Initial conditions

Test environment: normal; see subclauses G.2.1 and G.2.2.

Frequencies to be tested: mid range; see subclause G.2.4.

- 1) Connect SS, multi-path fading simulators and an AWGN source to the UE antenna connector as shown in Figure A.12.
- 2) Set up a call according to the Generic call setup procedure.
- 3) RF parameters are set up according to Table 7.6.1.1 and Table E 3.4.
- 4) Enter the UE into loopback test mode and start the loopback test.
- 5) Activate open loop Tx diversity function.
- 6) Set up fading simulators as fading condition case 1, which is described in Table D.2.2.1.

See [3] TS 34.108 and [4] TS 34.109 for details regarding generic call setup procedure and loopback test.

7.6.1.4.2 Procedure

- 1) Measure BLER in points specified in Table 7.6.1.2.

7.6.1.5 Test Requirements

For the parameters specified in Table 7.6.1.1 the BLER shall not exceed the value at the $DPCH_E_c/I_{or}$ specified in Table 7.6.1.2.

7.6.2 Demodulation of DCH in closed loop transmit diversity mode

7.6.2.1 Definition and applicability

The receive characteristic of the dedicated channel (DCH) in closed loop transmit diversity mode is determined by the Block Error Ratio (BLER). DCH is mapped into in Dedicated Physical Channel (DPCH).

The requirements and this test apply to all types of UTRA for the FDD UE.

7.6.2.2 Conformance requirements

For the parameters specified in Table 7.6.2.1 the average downlink $\frac{DPCH_E_c}{I_{or}}$ power shall be below the specified value for the BLER shown in Table 7.6.2.2.

Table 7.6.2.1: Test Parameters for DCH Reception in closed loop transmit diversity mode (Propagation condition: Case 1)

Parameter	Test 1 (Mode 1)	Test 2 (Mode 2)	Unit
\hat{I}_{or}/I_{oc}	9	9	dB
I_{oc}	-60	-60	dBm / 3.84 MHz
Information data rate	12.2	12.2	kbps
Feedback error ratio	4	4	%

Table 7.6.2.2: Test requirements for DCH reception in feedback transmit diversity mode

Test Number	$\frac{DPCH_E_c}{I_{or}}$ (see note)	BLER
1	-18.0 dB	10^{-2}
2	-18.3 dB	10^{-2}
Note: This is the total power from both antennas. Power sharing between antennas are closed loop mode dependent as specified in TS25.214.		

The reference for this requirement is [1] TS 25.101 subclause 8.6.2.1.

7.6.2.3 Test purpose

To verify that UE reliably demodulates the DPCH of the Node B while closed loop transmit diversity is enabled during the connection.

7.6.2.4 Method of test

7.6.2.4.1 ~~7.6.2.4.1~~ Initial conditions

Test environment: normal; see subclauses G.2.1 and G.2.2.

Frequencies to be tested: mid range; see subclause G.2.4.

- 1) Connect SS, multi-path fading simulators and an AWGN source to the UE antenna connector as shown in Figure A.12.
- 2) Set up a call according to the Generic call setup procedure.
- 3) RF parameters are set up according to Table 7.6.2.1 and Table E 3.5.
- 4) Enter the UE into loopback test mode and start the loopback test.

- 5) Activate closed loop Tx diversity function.
- 6) Set up fading simulators as fading condition case 1, which is described in Table D.2.2.1.

See [3] TS 34.108 and [4] TS 34.109 for details regarding generic call setup procedure and loopback test.

7.6.2.4.2 Procedure

- 1) Measure BLER in points specified in Table 7.6.2.2.

7.6.2.5 Test Requirements

For the parameters specified in Table 7.6.2.1 the BLER shall not exceed the value at the $DPCH_{Ec}/I_{or}$ specified in Table 7.6.2.2.

7.6.3 Demodulation of DCH in Site Selection Diversity Transmission Power Control mode

7.6.3.1 Definition and applicability

The bit error characteristics of UE receiver is determined in Site Selection Diversity Transmission Power Control (SSDT) mode. Two Node B emulators are required for this performance test. The delay profiles of signals received from different base stations are assumed to be the same but time shifted by 10 chip periods.

The requirements and this test apply to all types of UTRA for the FDD UE.

7.6.3.2 Conformance requirements

The downlink physical channels and their relative power to I_{or} are the same as those specified in clause E.3.3 irrespective of Node Bs and the test cases. $DPCH_{Ec}/I_{or}$ value applies whenever DPDCH in the cell is transmitted. In Test 1 and Test 3, the received powers at UE from two Node Bs are the same, while 3dB offset is given to one that comes from one of Node Bs for Test 2 and Test 4 as specified in Table 7.6.3.1.

For the parameters specified in Table 7.6.3.1 the average downlink $\frac{DPCH_{Ec}}{I_{or}}$ power shall be below the specified value for the BLER shown in Table 7.6.3.2.

Table 7.6.3.1: DCH parameters in multi-path propagation conditions during SSDT mode (Propagation condition: Case 1)

Parameter	Test 1	Test 2	Test 3	Test 4	Unit
Phase reference	P-CPICH				
\hat{I}_{or1}/I_{oc}	0	-3	0	0	dB
\hat{I}_{or2}/I_{oc}	0	0	0	-3	dB
I_{oc}	-60				dBm / 3.84 MHz
Information Data Rate	12.2	12.2	12.2	12.2	kbps
Feedback error rate*	4	4	4	4	%
Number of FBI bits assigned to "S" Field	1	1	2	2	
Code word Set	Long	Long	Short	Short	

*NOTE: Feedback error rate is defined as FBI bit error rate.

Table 7.6.3.2: DCH requirements in multi-path propagation conditions during SSDT Mode

Test Number	$\frac{DPCH_E_c}{I_{or}}$	BLER
1	-7.5 dB	10^{-2}
2	-6.5 dB	10^{-2}
3	-10.5 dB	10^{-2}
4	-9.2 dB	10^{-2}

The reference for this requirement is [1] TS 25.101 subclause 8.6.3.1.

7.6.3.3 Test purpose

To verify that UE reliably demodulates the DPCH of the selected Node B while site selection diversity is enabled during soft handover.

7.6.3.4 Method of test

7.6.3.4.1 ~~7.6.3.4.1~~ Initial conditions

Test environment: normal; see subclauses G.2.1 and G.2.2.

Frequencies to be tested: mid range; see subclause G.2.4.

- 1) Connect two SS's, multi-path fading simulators and an AWGN source to the UE antenna connector as shown in Figure A.11.
- 2) Set up a call according to the Generic call setup procedure, and RF parameters are set up according to Table 7.6.3.1 and Table 7.6.3.2.
- 3) Enter the UE into loopback test mode and start the loopback test.
- 4) Activate SSDT function.
- 5) Set up fading simulators as fading condition case 1, which is described in Table D.2.2.1.

7.6.3.4.2 Procedure

Measure BLER in points specified in Table 7.6.3.2..

7.6.3.5 Test Requirements

BLER shall not exceed the value at the $DPCH_E_c/I_{or}$ specified in Table 7.6.3.2.

7.7 Demodulation in Handover conditions

7.7.1 Demodulation of DCH in Inter-Cell Soft Handover

7.7.1.1 Definition and applicability

The bit error ratio characteristics of UE is determined during an inter-cell soft handover. During the soft handover a UE receives signals from different Base Stations. A UE has to be able to demodulate two P-CCPCH channels and to combine the energy of DCH channels. Delay profiles of signals received from different Base Stations are assumed to be the same but time shifted by 10 chips.

The receive characteristics of the different channels during inter-cell handover are determined by the Block Error Ratio (BLER) values.

The UE shall be tested only according to the data rate, supported. The data-rate-corresponding requirements shall apply to the UE.

7.7.1.2 Conformance requirements

For the parameters specified in Table 7.7.1.1 the average downlink $\frac{DPCH_Ec}{I_{or}}$ power shall be below the specified value for the BLER shown in Table 7.7.1.2.

Table 7.7.1.1: DCH parameters in multi-path propagation conditions during Soft Handoff (Case 3)

Parameter	Test 1	Test 2	Test 3	Test 4	Unit
Phase reference	P-CPICH				
\hat{I}_{or1}/I_{oc} and \hat{I}_{or2}/I_{oc}	0	0	3	6	dB
I_{oc}	-60				dBm / 3.84 MHz
Information Data Rate	12.2	64	144	384	kbps

Table 7.7.1.2: DCH requirements in multi-path propagation conditions during Soft Handoff (Case 3)

Test Number	$\frac{DPCH_Ec}{I_{or}}$	BLER
1	-15.2 dB	10^{-2}
2	-11.8 dB	10^{-1}
	-11.3 dB	10^{-2}
3	-9.6 dB	10^{-1}
	-9.2 dB	10^{-2}
4	-6.0 dB	10^{-1}
	-5.5 dB	10^{-2}

The reference for this requirement is [1] TS 25.101 subclause 8.7.1.1.

7.7.1.3 Test purpose

To verify that the BLER does not exceed the value at the $DPCH_Ec/I_{or}$ specified in Table 7.7.1.2.

7.7.1.4 Method of test

7.7.1.4.1 ~~7.7.1.4.1~~ Initial conditions

Test environment: normal; see subclauses G.2.1 and G.2.2.

Frequencies to be tested: mid range; see subclause G.2.4.

[TBD]

7.7.1.4.2 Procedures

- 1) Connect the SS, multi-path fading simulator and an AWGN noise source to the UE antenna connector as shown in Figure A.11.
- 2) Set up the call.
- 3) Set the test parameters for test 1-5 as specified in Table 7.7.1.1.

- 4) Count, at the SS, the number of information blocks transmitted and the number of correctly received information blocks at the UE.
- 5) Measure BLER of DCH channel.

7.7.1.5 Test requirements

For the parameters specified in Table 7.7.1.1 the BLER shall not exceed the value at the DPCH_Ec/Ior specified in Table 7.7.1.2.

7.7.2 Combining of TPC commands from radio links of different radio link sets

7.7.2.1 Definition and applicability

When a UE is in soft handover, multiple TPC commands may be received in each slot from different cells in the active set. In general, the TPC commands transmitted in the same slot in the different cells may be different and need to be combined to give TPC_cmd as specified in [5] TS25.214, in order to determine the required uplink power step.

The requirements and this test apply to all types of UTRA for the FDD UE.

7.7.2.2 Conformance requirements

Test parameters are specified in Table 7.7.2.1. The delay profiles of the signals received from the different cells are the same but time-shifted by 10 chips.

For Test 1, the uplink power changes between adjacent slots shall be as shown in Table 7.7.2.2 over the 4 consecutive slots. Note that this case is without an additional noise source I_{oc} .

For Test 2, the Cell1 and Cell2 TPC patterns are repeated a number of times. If the transmitted power of a given slot is increased compared to the previous slot, then a variable "Transmitted power UP" is increased by one, otherwise a variable "Transmitted power DOWN" is increased by one. The requirements for "Transmitted power UP" and "Transmitted power DOWN" are shown in Table 7.7.2.3.

Table 7.7.2.1: Parameters for TPC command combining

Parameter	Test 1	Test 2	Unit
Phase reference	P-CPICH		-
DPCH_Ec/Ior	-12		dB
\hat{I}_{or1} and \hat{I}_{or2}	-60		dBm / 3.84 MHz
I_{oc}	-	-60	dBm / 3.84 MHz
Power-Control-Algorithm	Algorithm 1		-
Cell 1 TPC commands over 4 slots	{0,0,1,1}		-
Cell 2 TPC commands over 4 slots	{0,1,0,1}		-
Information Data Rate	12.2		Kbps
Propagation condition	Static without AWGN source I_{oc}	Multi-path fading case 3	-

Table 7.7.2.2: Requirements for Test 1

Test Number	Required power changes over the 4 consecutive slots
1	Down, Down, Down, Up

Table 7.7.2.3: Requirements for Test 2

Test Number	Ratio (Transmitted power UP) / (Total number of slots)	Ratio (Transmitted power DOWN) / (Total number of slots)
2	≥0.25	≥0.5

The reference for this requirement is [1] TS 25.101 subclause 8.7.2.1.

7.7.2.3 Test purpose

To verify that the combining of TPC commands received in soft handover results in TPC_cmd being derived so as to meet the requirements stated in Tables 7.7.2.2 and 7.7.2.3.

7.7.2.4 Method of test

7.7.2.4.1 ~~7.7.2.4.1~~ Initial conditions

Test environment: normal; see subclauses G.2.1 and G.2.2.

Frequencies to be tested: mid range; see subclause G.2.4.

- 1) Connect two SS's to the UE antenna connector as shown in Figure A.13.
- 2) Set the test parameters as specified in Table 7.7.2.1 for Test 1.
- 3) Set up a call according to the Generic Call Setup procedure.
- 4) Signal the uplink DPCH power control parameters to use Algorithm 1 and a step size of 1dB.
- 5) Enter the UE into loopback test mode and start the loopback test.

See [3] TS 34.108 and [4] TS 34.109 for details regarding the generic call setup procedure and loopback test.

7.7.2.4.2 Procedures

- 1) Before proceeding with paragraph (2), set the output power of the UE, measured at the UE antenna connector, to be in the range -10 ± 9 dBm. This may be achieved by setting the downlink signal (\hat{I}_{or}) to yield an appropriate open loop output power and/or by generating suitable downlink TPC commands from the SSs.
- 2) Send the following sequences of TPC commands in the downlink from each SS over a period of 5 timeslots:

	Downlink TPC commands				
	Slot #0	Slot #1	Slot #2	Slot #3	Slot #4
SS1	0	0	0	1	1
SS2	0	0	1	0	1

- 3) Measure the average output power at the UE antenna connector in timeslots # 0, 1, 2, 3 and 4, not including the 25µs transient periods at the start and end of each slot.
- 4) End test 1 and disconnect UE.
- 5) Connect two SS's and an AWGN source to the UE antenna connector as shown in Figure A.11.
- 6) Initialise variables "Transmitted power UP" and "Transmitted power DOWN" to zero.
- 7) Set the test parameters as specified in Table 7.7.2.1 for Test 2.
- 8) Set up a call according to the Generic Call Setup procedure.
- 9) Signal the uplink DPCH power control parameters to use Algorithm 1 and a step size of 1dB.
- 10) Enter the UE into loopback test mode and start the loopback test.

11) Perform the following steps a) to d) [15] times:

- a) Before proceeding with step b), set the output power of the UE, measured at the UE antenna connector, to be in the range $-10\pm 9\text{dBm}$. This may be achieved by generating suitable downlink TPC commands from the SSs.
- b) Send the following sequences of TPC commands in the downlink from each SS over a period of 33 timeslots:

	Downlink TPC commands
SS1	1 0 0 1 1 0 0 1 1 0 0 1 1 0 0 1 1 0 0 1 1 0 0 1 1 0 0 1 1 0 0 1 1
SS2	1 0 1 0 1 0 1 0 1 0 1 0 1 0 1 0 1 0 1 0 1 0 1 0 1 0 1 0 1 0 1 0 1 0 1 0 1 0 1

- c) Measure the average output power at the UE antenna connector in each timeslot, not including the $25\mu\text{s}$ transient periods at the start and end of each slot.
- d) For each timeslot from the 2nd timeslot to the 33rd timeslot inclusive:
 - if the average power in that timeslot is greater than or equal to the average power in the previous timeslot plus 0.5dB, increment "Transmitted power UP" by 1;
 - if the average power in that timeslot is less than or equal to the average power in the previous timeslot minus 0.5dB, increment "Transmitted power DOWN" by 1.

7.7.2.5 Test requirements

- 1) In Step 2) of subclause 7.7.2.4.2, the average power in slot #1 shall be less than or equal to the average power in slot #0 minus 0.5dB.
- 2) In Step 2) of subclause 7.7.2.4.2, the average power in slot #2 shall be less than or equal to the average power in slot #1 minus 0.5dB.
- 3) In Step 2) of subclause 7.7.2.4.2, the average power in slot #3 shall be less than or equal to the average power in slot #2 minus 0.5dB.
- 4) In Step 2) of subclause 7.7.2.4.2, the average power in slot #4 shall be greater than or equal to the average power in slot #3 plus 0.5dB.
- 5) At the end of the test, "Transmitted power UP" shall be greater than or equal to [95] and "Transmitted power DOWN" shall be greater than or equal to [210].

NOTE: The test limits in requirements (4) and (5) have been computed to give a confidence level of [99.7]% that a UE which follows the core requirements will pass. The number of timeslots has been chosen to get a good compromise between the test time and the risk of passing a bad UE.

7.8 Power control in downlink

Power control in the downlink is the ability of the UE receiver to converge to required link quality set by the network while using as low power as possible in downlink. If a BLER target has been assigned to a DCCH (See Annex C.3), then it has to be such that outer loop is based on DTCH and not on DCCH.

7.8.1 Power control in the downlink, constant BLER target

7.8.1.1 Definition and applicability

Power control in the downlink is the ability of the UE receiver to converge to required link quality set by the network while using as low power as possible in downlink. If a BLER target has been assigned to a DCCH (See Annex C.3), then it has to be such that outer loop is based on DTCH and not on DCCH. The requirements and this test apply to all types of UTRA for the FDD UE.

7.8.1.2 Conformance requirements

For the parameters specified in Table 7.8.1.1 the downlink $\frac{DPCH_E_c}{I_{or}}$ power measured values, which are averaged over one slot, shall be below the specified value in Table 7.8.1.2 more than 90% of the time. BLER shall be as shown in Table 7.8.1.2. Power control in downlink is ON during the test.

Table 7.8.1.1: Test parameter for downlink power control, constant BLER target

Parameter	Test 1	Test 2	Unit
\hat{I}_{or}/I_{oc}	9	-1	dB
I_{oc}	-60		dBm / 3.84 MHz
Information Data Rate	12.2		kbps
Target quality on DTCH	0.01		BLER
Propagation condition	Case 4		
Maximum_DL_Power *	7		dB
Minimum_DL_Power *	-18		dB
Limited_Power_Raise_Used	"Not used"		-

Note *: Power is compared to P-CPICH as specified in [9].

Table 7.8.1.2: Requirements in downlink power control, constant BLER target

Parameter	Test 1	Test 2	Unit
$\frac{DPCH_E_c}{I_{or}}$	-16.0	-9.0	dB
Measured quality on DTCH	0.01±30%	0.01±30%	BLER

The reference for this requirement is [1] TS 25.101 subclause 8.8.1.1.

7.8.1.3 Test purpose

To verify that the UE receiver is capable of converging to required link quality set by network while using as low power as possible.

7.8.1.4 Method of test

7.8.1.4.1 ~~7.8.1.4.1~~ Initial conditions

Test environment: normal; see subclauses G.2.1 and G.2.2.

Frequencies to be tested: mid range; see subclause G.2.4.

- 1) Connect SS, multipath fading simulator and an AWGN source to the UE antenna connector as shown in Figure A.10.
- 2) Set up a call according to the Generic call setup procedure.
- 3) RF parameters are set up according to Table 7.8.1.1.
- 4) Enter the UE into loopback test mode and start the loopback test.
- 5) SS signals to UE target quality value on DTCH as specified in Table 7.8.1.1. SS will vary the physical channel power in downlink according to the TPC commands from UE. SS response time for UE TPC commands shall be one slot. At the same time BLER is measured. This is continued until the target quality value on DTCH is met, within the minimum accuracy requirement.

See [3] TS 34.108 and [4] TS 34.109 for details regarding generic call setup procedure and loopback test.

7.8.1.4.2 Procedure

- 1) After the target quality on DTCH is met, BLER is measured. Simultaneously the downlink $\frac{DPCH - E_c}{I_{or}}$ power averaged over one slot is measured. This is repeated until adequate amount of measurements is done to reach the required confidence level.
- 2) The measured quality on DTCH (BLER) and the measured downlink $\frac{DPCH - E_c}{I_{or}}$ power values averaged over one slot are compared to limits in Table 7.8.1.2.

7.8.1.5 Test Requirements

- a) The measured quality on DTCH does not exceed the values in Table 7.8.1.2.
- b) The downlink $\frac{DPCH - E_c}{I_{or}}$ power values, which are averaged over one slot, shall be below the values in Table 7.8.1.2 more than 90% of the time.

7.8.2 Power control in the downlink, initial convergence

7.8.2.1 Definition and applicability

This requirement verifies that DL power control works properly during the first seconds after DPCH connection is established. The requirements and this test apply to all types of UTRA for the FDD UE.

7.8.2.2 Conformance requirements

For the parameters specified in Table 7.8.2.1 the downlink DPCH_Ec/Ior power measured values, which are averaged over [50 ms], shall be within the range specified in Table 7.8.2.2 more than 90% of the time. T1 equals to [500 ms] and it starts [10 ms] after the DPDCH connection is initiated. T2 equals to [500 ms] and it starts when T1 has expired. Power control is ON during the test.

Table 7.8.2.1: Test parameters for downlink power control, initial convergence

Parameter	Test 1	Test 2	Test 3	Test 4	Unit
Target quality value on DTCH	0.01	0.01	0.1	0.1	BLER
Initial DPCH_Ec/Ior	-5.9	-25.9	-2.1	-22.1	dB
Information Data Rate	12.2	12.2	64	64	kbps
\hat{I}_{or}/I_{oc}	-1				dB
I_{oc}	-60				dBm/3.84 MHz
Propagation condition	[Static]				
Maximum_DL_Power *	7				dB
Minimum_DL_Power *	-18				dB
Limited_Power_Raise_Used	"Not used"				

Note *: Power is compared to P-CPICH as specified in [9]

Table 7.8.2.2: Requirements in downlink power control, initial convergence

Parameter	Test 1 and Test 2	Test 3 and Test 4	Unit
$\frac{DPCH_E_c}{I_{or}}$ during T1	$[-18.9 \leq DPCH_Ec/lor \leq -11.9]$	$[-15.1 \leq DPCH_Ec/lor \leq -8.1]$	dB
$\frac{DPCH_E_c}{I_{or}}$ during T2	$[-18.9 \leq DPCH_Ec/lor \leq -14.9]$	$[-15.1 \leq DPCH_Ec/lor \leq -11.1]$	dB

The reference for this requirement is [1] TS 25.101 subclause 8.8.2.1.

7.8.2.3 Test purpose

To verify that DL power control works properly during the first seconds after DPCH connection is established.

7.8.2.4 Method of test

7.8.2.4.1 ~~7.8.2.4.1~~ Initial conditions

Test environment: normal; see subclauses G.2.1 and G.2.2.

Frequencies to be tested: mid range; see subclause G.2.4.

- 1) Connect SS, multipath fading simulator and an AWGN source to the UE antenna connector as shown in Figure A.10.

7.8.2.4.2 Procedure

- 1) Set up call using test parameters according to Table 7.8.2.1.
- 2) Measure $\frac{DPCH_E_c}{I_{or}}$ power averaged over [50 ms] during T1. T1 starts [10 ms] after DPDCH connection is initiated and T1 equals to [500 ms]
- 3) Measure $\frac{DPCH_E_c}{I_{or}}$ power averaged over [50 ms] during T2. T2 starts, when T1 has expired and T2 equals to [500 ms]

7.8.2.5 Test Requirements

- a) The downlink $\frac{DPCH_E_c}{I_{or}}$ power values shall be within the range specified in Table 7.8.2.2 during T1 more than 90% of the time.
- b) The downlink $\frac{DPCH_E_c}{I_{or}}$ power values shall be within the range specified in Table 7.8.2.2 during T2 more than 90% of the time.

7.8.3 Power control in the downlink, wind up effects

7.8.3.1 Definition and applicability

This requirement verifies that, after the downlink maximum power is limited in the UTRAN and it has been released again, the downlink power control in the UE does not have a wind up effect, i.e. the required DL power has increased during time period the DL power was limited. The requirements and this test apply to all types of UTRA for the FDD UE.

7.8.3.2 Conformance requirements

This test is run in three stages where stage 1 is for convergence of the power control loop, in stage two the maximum downlink power for the dedicated channel is limited not to be higher than the parameter specified in Table 7.8.3.1. All parameters used in the three stages are specified in Table 7.8.3.1. The downlink $\frac{DPCH_E_c}{I_{or}}$ power measured values,

which are averaged over one slot, during stage 3 shall be lower than the value specified in Table 7.8.3.2 more than 90% of the time. Power control of the UE is ON during the test.

Table 7.8.3.1: Test parameter for downlink power control, wind-up effects

Parameter	Test 1			Unit
	Stage 1	Stage 2	Stage 3	
Time in each stage	>15	5	0.5	s
\hat{I}_{or}/I_{oc}	5			dB
I_{oc}	-60			dBm/3.84 MHz
Information Data Rate	12.2			kbps
Quality target on DTCH	0.01			BLER
Propagation condition	Case 4			
Maximum_DL_Power *	7	-6.2	7	dB
Minimum_DL_Power *	-18			dB
Limited_Power_Raise_Used	"Not used"			-

Note *: Power is compared to P-CPICH as specified in [9]

Table 7.8.3.2: Requirements in downlink power control, wind-up effects

Parameter	Test 1, stage 3	Unit
$\frac{DPCH_E_c}{I_{or}}$	[-13.3]	dB

The reference for this requirement is [1] TS 25.101 subclause 8.8.3.1.

7.8.3.3 Test purpose

To verify that the UE downlink power control does not require too high downlink power during a period after the downlink power is limited by the UTRAN.

7.8.3.4 Method of test

7.8.3.4.1 ~~7.8.3.4.1~~ Initial conditions

Test environment: normal; see subclauses G.2.1 and G.2.2.

Frequencies to be tested: mid range; see subclause G.2.4.

- 1) Connect SS, multipath fading simulator and an AWGN source to the UE antenna connector as shown in Figure A.10.
- 2) Set up a call according to the Generic call setup procedure.

- 3) Enter the UE into loopback test mode and start the loopback test.
- 4) RF parameters are set up according to Table 7.8.3.1. Stage 1 is used for the power control to converge and during Stage 2 the maximum downlink power is limited by UTRAN.

See [3] TS 34.108 and [4] TS 34.109 for details regarding generic call setup procedure and loopback test.

7.8.3.4.2 Procedure

- 1) Measure $\frac{DPCH_E_c}{I_{or}}$ power during stage 3 according to Table 7.8.3.1.

7.8.3.5 Test Requirements

The downlink $\frac{DPCH_E_c}{I_{or}}$ power values, which are averaged over one slot, shall be lower than the level specified in table 7.8.3.2 during stage 3 more than 90% of the time.

7.9 Downlink compressed mode

Downlink compressed mode is used to create gaps in the downlink transmission, to allow the UE to make measurements on other frequencies.

7.9.1 Single link performance

7.9.1.1 Definition and applicability

The receiver single link performance of the Dedicated Traffic Channel (DCH) in compressed mode is determined by the Block Error Ratio (BLER) and transmitted DPCH_Ec/Ior power in the downlink.

The compressed mode parameters are given in clause C.5. Tests 1 and 2 are using Set 1 compressed mode pattern parameters from Table C.5.1 in clause C.5 while tests 3 and 4 are using Set 2 compressed mode patterns from the same table.

The requirements and this test apply to all types of UTRA for the FDD UE.

7.9.1.2 Conformance requirements

For the parameters specified in Table 7.9.1 the downlink $\frac{DPCH_E_c}{I_{or}}$ power measured values, which are averaged over one slot, shall be below the specified value in Table 7.9.2 more than 90% of the time. The measured quality on DTCH shall be as required in Table 7.9.2.

Downlink power control is ON during the test. Uplink TPC commands shall be error free. System simulator shall increase the transmitted power during compressed frames by the same amount that UE is expected to increase its SIR target during those frames.

Table 7.9.1: Test parameter for downlink compressed mode

Parameter	Test 1	Test 2	Test 3	Test 4	Unit
Delta SIR1	0	3	0	3	dB
Delta SIR after1	0	3	0	3	dB
Delta SIR2	0	0	0	0	dB
Delta SIR after2	0	0	0	0	dB
\hat{I}_{or}/I_{oc}	9				dB
I_{oc}	-60				dBm / 3.84 MHz
Information Data Rate	12.2				kbps
Propagation condition	Case 2				
Target quality value on DTCH	0.01				BLER
Maximum DL Power *	7				dB
Minimum DL Power *	-18				dB
Limited Power Raise Used	"Not used"				-

Note *: Power is compared to P-CPICH as specified in [9].

Table 7.9.2: Requirements in downlink compressed mode

Parameter	Test 1	Test 2	Test 3	Test 4	Unit
$\frac{DPCH - E_c}{I_{or}}$	-14.8	No requirements	-15.4	No requirements	dB
Measured quality of compressed and recovery frames	No requirements	<0.001	No requirements	<0.001	BLER
Measured quality on DTCH	0.01 ± 30 %				BLER

The reference for this requirement is [1] TS 25.101 subclause 8.9.1.1.

7.9.1.3 Test purpose

The purpose of this test is to verify the reception of DPCH in a UE while downlink is in a compressed mode. The UE needs to preserve the BLER using sufficient low DL power. It is also verified that UE applies the Delta SIR values, which are signaled from network, in its outer loop power control algorithm.

7.9.1.4 Method of test

7.9.1.4.1 ~~7.9.1.4.1~~ Initial conditions

Test environment: normal; see subclauses G.2.1 and G.2.2.

Frequencies to be tested: mid range; see subclause G.2.4.

- 1) Connect SS, multipath fading simulator and an AWGN source to the UE antenna connector as shown in Figure A.10.
- 2) Set up a call according to the Generic call setup procedure.
- 3) RF parameters are set up according to Table 7.9.1. SS shall increase the transmitted power during compressed mode frames by the same amount that UE is expected to increase its SIR target during those frames
- 4) Set compressed mode parameters according to Table C.5.1. Tests 1 and 2 are using Set 1 compressed mode pattern parameters and while tests 3 and 4 are using Set 2 compressed mode pattern parameters.
- 5) Enter the UE into loopback test mode and start the loopback test.
- 6) SS signals to UE target quality value on DTCH as specified in Table 7.9.1. Uplink TPC commands shall be error free. SS will vary the physical channel power in downlink according to the TPC commands from UE. SS

response time for UE TPC commands shall be one slot. At the same time BLER is measured. This is continued until the target quality value on DTCH is met, within the minimum accuracy requirement.

See [3] TS 34.108 and [4] TS 34.109 for details regarding generic call setup procedure and loopback test.

7.9.1.4.2 Procedure

- 1) Test 1: Measure quality on DTCH and $\frac{DPCH - E_c}{I_{or}}$ power values averaged over one slot.
- 2) Test 2: Measure quality on DTCH and quality of compressed and recovery frames.
- 3) Test 3: Measure quality on DTCH and $\frac{DPCH - E_c}{I_{or}}$ power values averaged over one slot.
- 4) Test 4: Measure quality on DTCH and quality of compressed and recovery frames.

7.9.1.5 Test requirements

- a) Test 1: The downlink $\frac{DPCH - E_c}{I_{or}}$ power values averaged over one slot shall be below the values in Table 7.9.2 more than 90% of the time. The measured quality on DTCH shall be as required in Table 7.9.2.
- b) Test 2: Measured quality on DTCH and measured quality of compressed and recovery frames do not exceed the values in Table 7.9.2.
- c) Test3: The downlink $\frac{DPCH - E_c}{I_{or}}$ power values averaged over one slot shall be below the values in Table 7.9.2 more than 90% of the time. The measured quality on DTCH shall be as required in Table 7.9.2.
- d) Test 4: Measured quality on DTCH and measured quality of compressed and recovery frames do not exceed the values in Table 7.9.2.

7.10 Blind transport format detection

7.10.1 Definition and applicability

Performance of Blind transport format detection is determined by the Block Error Ratio (BLER) values and by the measured average transmitted DPCH_Ec/Ior value.

7.10.2 Conformance requirements

For the parameters specified in Table 7.10.1 the average downlink $\frac{DPCH - E_c}{I_{or}}$ power shall be below the specified value for the BLER and FDR shown in Table 7.10.2.

Table 7.10.1: Test parameters for Blind transport format detection

Parameter	Test 1	Test 2	Test 3	Test 4	Test 5	Test 6	Unit
\hat{I}_{or}/I_{oc}	-1				-3		dB
I_{oc}	-60						dBm / 3.84 MHz
Information Data Rate	12.2 (rate 1)	7.95 (rate 2)	1.95 (rate 3)	12.2 (rate 1)	7.95 (rate 2)	1.95 (rate 3)	kbps
propagation condition	static			multi-path fading case 3			-
TFCI	off						-

Table 7.10.2: The Requirements for DCH reception in Blind transport format detection

Test Number	$\frac{DPCH_E_c}{I_{or}}$	BLER	FDR
1	[-17.7dB]	10^{-2}	10^{-4}
2	[-17.8dB]	10^{-2}	10^{-4}
3	[-18.4dB]	10^{-2}	10^{-4}
4	[-13.0dB]	10^{-2}	10^{-4}
5	[-13.2dB]	10^{-2}	10^{-4}
6	[-13.8dB]	10^{-2}	10^{-4}

* The value of DPCH_Ec/I_{or}, I_{oc}, and I_{or}/I_{oc} are defined in case of DPCH is transmitted

Note: In the test, 9 deferent Transport Format Combinations (Table.7.10.3) are sent during the call set up procedure, so that UE has to detect correct transport format in this 9 candidates.

Table.7.10.3: Transport format combinations informed during the call set up procedure in the test

	1	2	3	4	5	6	7	8	9
DTCH	12.2k	10.2k	7.95k	7.4k	6.7k	5.9k	5.15k	4.75k	1.95k
DCCH					2.4k				

7.10.3 Test purpose

To verify the ability of the blind transport format detection to receive a predefined test signal, representing a static propagation channel for the wanted and for the co-channel signals from serving and adjacent cells, with a block error ratio (BLER) and false transport format detection ratio (FDR) not exceeding a specified value.

To verify the ability of the blind transport format detection to receive a predefined test signal, representing a multi-path propagation channel for the wanted and for the co-channel signals from serving and adjacent cells, with a block error ratio (BLER) and false transport format detection ratio (FDR) not exceeding a specified value.

7.10.4 Method of test

7.10.4.1 ~~7.10.4.1~~ Initial conditions

Test environment: normal; see subclauses G.2.1 and G.2.2.

Frequencies to be tested: mid range; see subclause G.2.4.

1. Connect the SS and AWGN noise source to the UE antenna connector as shown in Figure A.9 in the case for test 1-3. Connect the SS, multipath fading simulator and an AWGN noise source to the UE antenna connector as shown in Figure A.10 in the case of test 4-6.
2. Set up a call according to the Generic call setup procedure.
3. Set the test parameters for test 1-6 as specified Table 7.10.1 and Table 7.10.2.
4. Enter the UE into loopback test mode and start the loopback test.
5. In the case of test 4-6, Setup fading simulator as fading condition case 3 which are described in Table D.2.2.1.

7.10.4.2 Procedure

Measure BLER and FDR of DCH.

7.10.5 Test requirements

BLER and FDR shall not exceed the values at the DPCH_Ec/I_{or} specified in Table 7.10.2.

Annex G (normative): Environmental conditions

G.1 General

This normative annex specifies the environmental requirements of the UE. Within these limits the requirements of this specifications shall be fulfilled.

G.2 Environmental requirements

The requirements in this clause apply to all types of UE(s)

G.2.1 Temperature

The UE shall fulfil all the requirements in the full temperature range of:

Table G.2.1.1

+15°C to +35°C	for normal conditions (with relative humidity of 25 % to 75 %)
-10°C to +55°C	for extreme conditions (see IEC publications 68-2-1 and 68-2-2)

Outside this temperature range the UE, if powered on, shall not make ineffective use of the radio frequency spectrum. In no case shall the UE exceed the transmitted levels as defined in [1] TS 25.101 for extreme operation.

Some tests in this TS are performed also in extreme temperature conditions. These test conditions are denoted as TL (temperature low, -10°C) and TH (temperature high, +55°C).

G.2.2 Voltage

The UE shall fulfil all the requirements in the full voltage range, i.e. the voltage range between the extreme voltages.

The manufacturer shall declare the lower and higher extreme voltages and the approximate shutdown voltage. For the equipment that can be operated from one or more of the power sources listed below, the lower extreme voltage shall not be higher, and the higher extreme voltage shall not be lower than that specified below.

Table G.2.2.1

Power source	Lower extreme Voltage	Higher extreme voltage	Normal conditions Voltage
AC mains	0.9 * nominal	1.1 * nominal	Nominal
Regulated lead acid battery	0.9 * nominal	1.3 * nominal	1.1 * nominal
Non regulated batteries: - Leclanché / lithium - Mercury/nickel & cadmium	0.85 * nominal 0.90 * nominal	Nominal Nominal	Nominal Nominal

Outside this voltage range the UE if powered on, shall not make ineffective use of the radio frequency spectrum. In no case shall the UE exceed the transmitted levels as defined in [1] TS 25.101 for extreme operation. In particular, the UE shall inhibit all RF transmissions when the power supply voltage is below the manufacturer declared shutdown voltage.

Some tests in this TS are performed also in extreme voltage conditions. These test conditions are denoted as VL (lower extreme voltage) and VH (higher extreme voltage).

G.2.3 Vibration

The UE shall fulfil all the requirements when vibrated at the following frequency/amplitudes:

Table G.2.3.1

Frequency	ASD (Acceleration Spectral Density) random vibration
5 Hz to 20 Hz	0.96 m ² /s ³
20 Hz to 500 Hz	0.96 m ² /s ³ at 20 Hz, thereafter –3 dB / Octave

Outside the specified frequency range the UE, if powered on, shall not make ineffective use of the radio frequency spectrum. In no case shall the UE exceed the transmitted levels as defined in [1] TS 25.101 for extreme operation.

G.2.4 Specified frequency range

The manufacturer shall declare, which of the frequency bands defined in subclause 4.2 is supported by the UE.

Some tests in this TS are performed also in low, mid and high range of the operating frequency band of the UE. The UARFCN's to be used for low, mid and high range are defined in [3] TS 34.108 subclause 5.1.1.

CHANGE REQUEST

⌘ **TS 34.121 CR 093** ⌘ rev ⌘ Current version: **3.4.0** ⌘

For **HELP** on using this form, see bottom of this page or look at the pop-up text over the ⌘ symbols.

Proposed change affects: ⌘ (U)SIM ME/UE Radio Access Network Core Network

Title:	⌘ Editorial corrections		
Source:	⌘ T1/RF		
Work item code:	⌘ 	Date:	⌘ 14 May, 2001
Category:	⌘ D	Release:	⌘ R99
<p>Use <u>one</u> of the following categories:</p> <p>F (essential correction) A (corresponds to a correction in an earlier release) B (Addition of feature), C (Functional modification of feature) D (Editorial modification)</p> <p>Detailed explanations of the above categories can be found in 3GPP TR 21.900.</p>		<p>Use <u>one</u> of the following releases:</p> <p>2 (GSM Phase 2) R96 (Release 1996) R97 (Release 1997) R98 (Release 1998) R99 (Release 1999) REL-4 (Release 4) REL-5 (Release 5)</p>	

Reason for change:	⌘ Editorial error corrections		
Summary of change:	⌘ Correct tables 5.4.1.3 and 5.5.2.2		
Consequences if not approved:	⌘ Misunderstandings of readers may be caused.		

Clauses affected:	⌘ 5.4.1.4.1 and 5.5.2.4.1		
Other specs affected:	⌘ <input type="checkbox"/> Other core specifications	⌘ 	
	<input type="checkbox"/> Test specifications		
	<input type="checkbox"/> O&M Specifications		
Other comments:	⌘ 		

How to create CRs using this form:

Comprehensive information and tips about how to create CRs can be found at: http://www.3gpp.org/3G_Specs/CRs.htm. Below is a brief summary:

- 1) Fill out the above form. The symbols above marked ⌘ contain pop-up help information about the field that they are closest to.
- 2) Obtain the latest version for the release of the specification to which the change is proposed. Use the MS Word "revision marks" feature (also known as "track changes") when making the changes. All 3GPP specifications can be downloaded from the 3GPP server under <ftp://www.3gpp.org/specs/> For the latest version, look for the directory name with the latest date e.g. 2000-09 contains the specifications resulting from the September 2000 TSG meetings.
- 3) With "track changes" disabled, paste the entire CR form (use CTRL-A to select it) into the specification just in front of the clause containing the first piece of changed text. Delete those parts of the specification which are not relevant to the change request.

5.3.5 Test Requirements

For all measured bursts, the frequency error, derived in step 2), shall not exceed $\pm(0.1 \text{ ppm} + 10 \text{ Hz})$.

NOTE: If the above Test Requirement differs from the Minimum Requirement then the Test Tolerance applied for this test is non-zero. The Test Tolerance for this test is defined in Annex F.2 and the explanation of how the Minimum Requirement has been relaxed by the Test Tolerance is given in Annex F.4.

5.4 Output Power Dynamics in the Uplink

Power control is used to limit the interference level.

5.4.1 Open Loop Power Control in the Uplink

5.4.1.1 Definition and applicability

Open loop power control in the uplink is the ability of the UE transmitter to set its output power to a specific value. This function is used for PRACH transmission and based on the information from Node B using BCCH and the downlink received signal power level of the CPICH. The information from Node B includes transmission power of CPICH and uplink interference power level.

The requirements and this test apply to all types of UTRA for the FDD UE.

5.4.1.2 Conformance requirements

The UE open loop power is defined as the average power in a timeslot or ON power duration, whichever is available, and they are measured with a filter that has a Root-Raised Cosine (RRC) filter response with a roll off $\alpha = 0.22$ and a bandwidth equal to the chip rate.

The UE open loop power control tolerance is given in Table 5.4.1.1.

Table 5.4.1.1: Open loop power control tolerance

Normal conditions	$\pm 9 \text{ dB}$
Extreme conditions	$\pm 12 \text{ dB}$

The reference for this requirement is [1] TS 25.101 subclause 6.4.1.

5.4.1.3 Test purpose

The power of the received signal and the BCCH information control the power of the transmitted signal with the target to transmit at lowest power acceptable for proper communication.

The test stresses the ability of the receiver to measure the received power correctly over the receiver dynamic range.

The test purpose is to verify that the UE open loop power control tolerance does not exceed the described value shown in Table 5.4.1.1.

An excess error of the open loop power control decreases the system capacity.

5.4.1.4 Method of test

5.4.1.4.1 Initial conditions

- 1) Connect the SS to the UE antenna connector as shown in Figure A.1.
- 2) A call is set up according to the Generic call setup procedure, and \hat{I}_{or} is set up according to Table 5.4.1.2. The relative power level of downlink physical channels to I_{or} are set up according to Annex E.2.1. The RACH procedure within the call setup is used for the test.

See [3] TS 34.108 for details regarding generic call setup procedure.

Table 5.4.1.2: Test parameters for Open Loop Power Control (UE)

Parameter	Level / Status	Unit
\hat{I}_{or}	See Table 5.4.1.3	dBm / 3.84 MHz

Table 5.4.1.3: Test parameters for Open Loop Power Control (SS)

Parameter	RX Upper dynamic end	RX-middle	RX-Sensitivity level
$\hat{I}_{or}^{3)}$	-25.0 dBm / 3.84 MHz	-65.7 dBm / 3.84 MHz	-106.7 dBm / 3.84 MHz
CPICH_RSCP ^{3),4)}	-28.3 dBm	-69 dBm	-110 dBm
Primary CPICH DL TX power	+19 dBm	+28 dBm	+19 dBm
Simulated path loss = Primary CPICH DL TX power – CPICH_RSCP	+47.3 dB	+97 dB	+129 dB
UL interference	-75 dBm	-101 dBm	-110 dBm
Constant Value	-10 dB	-10 dB	-10 dB
Expected nominal UE TX power ⁵⁾	-37.7dBm	-14dBm	+9 dBm ²⁾

NOTE 1: While the SS transmit power shall cover the receiver input dynamic range, the logical parameters: Primary CPICH DL TX power, UL interference, Constant Value are chosen to achieve a UE TX power, located within the TX output power dynamic range of a class 4 UE.

NOTE 2: Nominal TX output power 9 dBm allows to check the open loop power algorithm within the entire tolerance range (9 dBm ± 12 dB; 9 dBm + 12 dB = 21 dBm = max power class 4).

NOTE 3: The power level of S-CCPCH should be defined because S-CCPCH is transmitted during Preamble RACH transmission period. The power level of S-CCPCH is temporarily set to -10.3dB relative to \hat{I}_{or} . However, it is necessary to check whether the above S-CCPCH level is enough to establish a connection with the reference measurement channels.

NOTE 4: The purpose of this parameter is to calculate the Expected nominal UE TX power.

NOTE 5: The Expected nominal UE TX power is calculated by using the equation in the clause 8.5.9 Open Loop Power Control of [8]TS25.331.

5.4.1.4.2 Procedure

- 1) Set the TX output level of the SS to obtain \hat{I}_{or} at the UE antenna connector. \hat{I}_{or} shall be according to Table 5.4.1.3 (-25 dBm / 3.84 MHz).
- 2) Measure the first RACH preamble output power of the UE according to Annex B.
- 3) Repeat the above measurement for all SS levels in Table 5.4.1.3.

5.4.1.5 Test requirements

The deviation with respect to the Expected nominal UE TX power (Table 5.4.1.3), derived in step 2), shall not exceed the prescribed tolerance in Table 5.4.1.1.

5.5.2 Transmit ON/OFF Time mask

5.5.2.1 Definition and applicability

The time mask for transmit ON/OFF defines the ramping time allowed for the UE between transmit OFF power and transmit ON power. Possible ON/OFF scenarios are PRACH, CPCH or uplink compressed mode.

The requirements and this test apply to all types of UTRA for the FDD UE.

5.5.2.2 Conformance requirements

The transmit power levels versus time shall meet the mask specified in Figure 5.5.1 for PRACH preambles, and the mask in Figure 5.5.2 for all other cases. The signal is measured with a filter that has a Root-Raised Cosine (RRC) filter response with a roll off $\alpha = 0.22$ and a bandwidth equal to the chip rate.

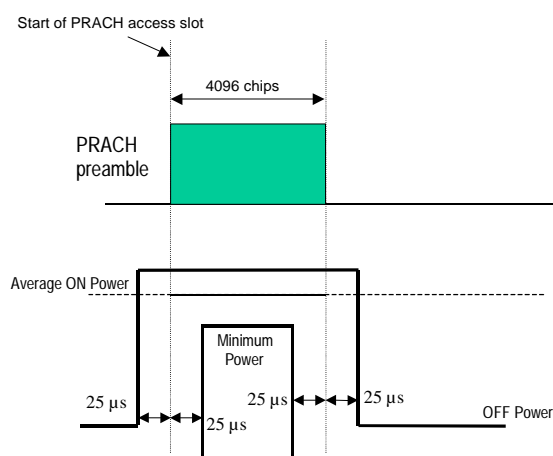

Figure 5.5.1: Transmit ON/OFF template for PRACH preambles

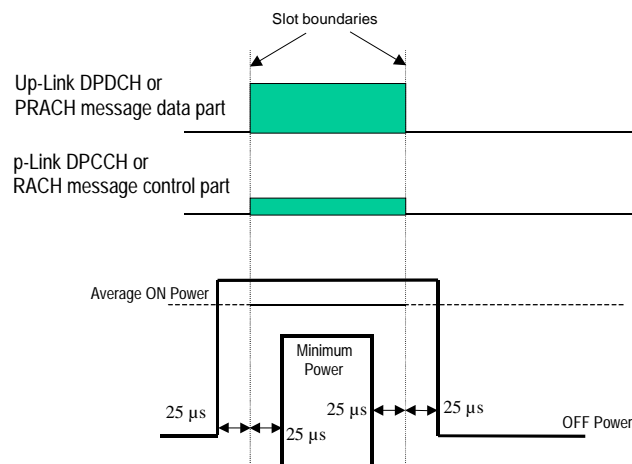

Figure 5.5.2: Transmit ON/OFF template for all other On/Off cases

OFF Power is defined in 5.5.1.

ON power is defined as either case as follows. The specification depends on each possible case.

- First preamble of PRACH: Open loop accuracy (Table 5.4.1.1).
- During preamble ramping of the RACH and between final RACH preamble and RACH message part: Accuracy depending on size of the required power difference (Table 5.5.2.1).
- After transmission gaps in compressed mode: Accuracy as in Table 5.7.1.

- Power step to Maximum Power: Maximum power accuracy (Table 5.2.1).

Table 5.5.2.1: Transmitter power difference tolerance for RACH preamble ramping, and between final RACH preamble and RACH message part

Power difference size ΔP [dB]	Transmitter power difference tolerance [dB]
0	+/- 1 dB
1	+/- 1 dB
2	+/- 1.5 dB
3	+/- 2 dB
$4 \leq \Delta P \leq 10$	+/- 2.5 dB
$11 \leq \Delta P \leq 15$	+/- 3.5 dB
$16 \leq \Delta P \leq 20$	+/- 4.5 dB
$21 \leq \Delta P$	+/- 6.5 dB

The reference for this requirement is [1] TS 25.101 subclause 6.5.2.1.

This is tested using PRACH operation.

The minimum requirement for ON power is defined in subclause 5.4.1.2.

The minimum requirement for OFF power is defined in subclause 5.5.1.2.

Note: The main objective for this test case is to check the ramp-up/down power shape. A test case using the first preamble of PRACH is enough to cover the objective.

5.5.2.3 Test purpose

To verify that the UE transmit ON/OFF power levels versus time meets the described mask shown in Figure 5.5.1 and Figure 5.5.2.

An excess error of transmit ON/OFF response increases the interference to other channels, or increases transmission errors in the up link own channel.

5.5.2.4 Method of test

5.5.2.4.1 Initial conditions

- 1) Connect the SS to the UE antenna connector as shown in Figure A.1.
- 2) A call is set up according to the Generic call setup procedure, and \hat{I}_{Or} are set up according to Table 5.5.2.2. The relative power level of downlink physical channels to I_{Or} are set up according to Annex E.2.1.

The RACH procedure within the call setup is used for the test.

See [3] TS 34.108 for details regarding generic call setup procedure.

Table 5.5.2.2: Test parameters for Transmit ON/OFF Time mask (UE)

Parameter	Level / Status	Unit
\hat{I}_{Or}	See Table 5.5.2.23	dBm / 3.84 MHz

Table 5.5.2.3: Test parameters for Transmit ON/OFF Time mask (SS)

Parameter	Power Class 1	Power Class 2	Power Class 3	Power Class 4	Unit
\hat{I}_{or} ¹⁾	-106.7	-106.7	-106.7	-106.7	dBm / 3.84 MHz
CPICH_RSCP ^{1),2)}	-110	-110	-110	-110	dBm
Primary CPICH DL TX power	+19	+19	+19	+19	dBm
Simulated path loss = Primary CPICH DL TX power – CPICH_RSCP	+129	+129	+129	+129	dB
UL interference	-86	-92	-95	-98	dBm
Constant Value	-10	-10	-10	-10	dB
Expected nominal UE TX power ³⁾	+33	+27	+24	+21	dBm

NOTE 1: The power level of S-CCPCH should be defined because S-CCPCH is transmitted during Preamble RACH transmission period. The power level of S-CCPCH is temporarily set to -10.3dB relative to \hat{I}_{or} . However, it is necessary to check whether the above S-CCPCH level is enough to establish a connection with the reference measurement channels.

NOTE 2: The purpose of this parameter is to calculate the Expected nominal UE TX power.

NOTE 3: The Expected nominal UE TX power is calculated by using the equation in the clause 8.5.9 Open Loop Power Control of [8] TS25.331.

5.5.2.4.2 Procedure

- 1) Set the TX output level of the SS to obtain \hat{I}_{or} at the UE antenna connector and select the test parameters of Table 5.5.2.3 according to the power class. \hat{I}_{or} shall be according to Table 5.5.2.3 (-106.7 dBm / 3.84 MHz).
- 2) Measure the first RACH preamble output power (ON power) of the UE. The measurements shall not include the transient periods.
- 3) Measure the OFF power immediately before and after the first RACH preamble (ON power). The measurements shall not include the transient periods.

5.5.2.5 Test requirements

The deviation with respect to the Expected nominal UE TX power (Table 5.5.2.3), derived in step 2), shall not exceed the prescribed upper tolerance in Table 5.2.1 (Subclause 5.2.2) and lower tolerance in Table 5.4.1.1. (Subclause 5.4.1.2).

The measured leakage power, derived in step 3), shall be below -56 dBm. (Subclause 5.5.1.2).

5.6 Change of TFC

5.6.1 Definition and applicability

A change of TFC (Transport Format Combination) in uplink means that the power in the uplink varies according to the change in data rate. DTX, where the DPCH is turned off, is a special case of variable data, which is used to minimise the interference between UE(s) by reducing the UE transmit power when voice, user or control information is not present.

The requirements and this test apply to all types of UTRA for the FDD UE.

CHANGE REQUEST

⌘ **TS 34.121 CR 094** ⌘ rev ⌘ Current version: **3.4.0** ⌘

For **HELP** on using this form, see bottom of this page or look at the pop-up text over the ⌘ symbols.

Proposed change affects: ⌘ (U)SIM ME/UE Radio Access Network Core Network

Title:	⌘ Modifications to test for inner loop power control in the uplink (FDD)				
Source:	⌘ T1/RF				
Work item code:	⌘ 	Date:	⌘ 14 May, 2001		
Category:	⌘ C	Release:	⌘ R99		
<i>Use <u>one</u> of the following categories:</i> F (essential correction) A (corresponds to a correction in an earlier release) B (Addition of feature), C (Functional modification of feature) D (Editorial modification) Detailed explanations of the above categories can be found in 3GPP TR 21.900.			<i>Use <u>one</u> of the following releases:</i> 2 (GSM Phase 2) R96 (Release 1996) R97 (Release 1997) R98 (Release 1998) R99 (Release 1999) REL-4 (Release 4) REL-5 (Release 5)		

Reason for change:	⌘ To keep consistency with the core specification
Summary of change:	⌘ Modify the Conformance requirements and Test requirements
Consequences if not approved:	⌘ Inconsistencies with the core specification are caused.

Clauses affected:	⌘ 5.4.2
Other specs affected:	⌘ <input type="checkbox"/> Other core specifications ⌘ <input type="checkbox"/> Test specifications <input type="checkbox"/> O&M Specifications
Other comments:	⌘

How to create CRs using this form:

Comprehensive information and tips about how to create CRs can be found at: http://www.3gpp.org/3G_Specs/CRs.htm. Below is a brief summary:

- 1) Fill out the above form. The symbols above marked ⌘ contain pop-up help information about the field that they are closest to.
- 2) Obtain the latest version for the release of the specification to which the change is proposed. Use the MS Word "revision marks" feature (also known as "track changes") when making the changes. All 3GPP specifications can be downloaded from the 3GPP server under <ftp://www.3gpp.org/specs/>. For the latest version, look for the directory name with the latest date e.g. 2000-09 contains the specifications resulting from the September 2000 TSG meetings.
- 3) With "track changes" disabled, paste the entire CR form (use CTRL-A to select it) into the specification just in front of the clause containing the first piece of changed text. Delete those parts of the specification which are not relevant to the change request.

5.4.2 Inner Loop Power Control in the Uplink

5.4.2.1 Definition and applicability

Inner loop power control in the uplink is the ability of the UE transmitter to adjust its output power in accordance with one or more TPC commands received in the downlink.

The power control step is the change in the UE transmitter output power in response to a single TPC command, TPC_cmd, derived at the UE.

This clause does not cover all the requirements of compressed mode or soft handover.

The requirements and this test apply to all types of UTRA for the FDD UE.

5.4.2.2 ~~Minimum~~ ~~Conformance~~ requirements

The UE transmitter shall have the capability of changing the output power with a step size of 1, 2 and 3 dB according to the value of Δ_{TPC} or $\Delta_{\text{RP-TPC}}$, in the slot immediately after the TPC_cmd can be derived.

- The transmitter output power step due to inner loop power control shall be within the range shown in Table 5.4.2.1. ~~The Maximum power threshold is defined as the lowest permissible maximum output power for the UE power class, as defined in Table 5.2.1. The Minimum power threshold is defined as -50 dBm.~~
- ~~When the transmitter output power is between the Minimum and Maximum power thresholds, \pm~~ The transmitter average output power step due to inner loop power control shall be within the range shown in Table 5.4.2.2. Here a TPC_cmd group is a set of TPC_cmd values derived from a corresponding sequence of TPC commands of the same duration.

~~NOTE: ± 3 dB inner loop power control steps are only used in compressed mode.~~

The inner loop power step is defined as the relative power difference between the average power of the original (reference) timeslot and the average power of the target timeslot, not including the transient duration. The transient duration is from $25\mu\text{s}$ before the slot boundary to $25\mu\text{s}$ after the slot boundary. The power is measured with a filter that has a Root-Raised Cosine (RRC) filter response with a roll off $\alpha = 0.22$ and a bandwidth equal to the chip rate.

Table 5.4.2.1: Transmitter power control tolerance

TPC_cmd	Transmitter power control range (all units are in dB)					
	1 dB step size		2 dB step size		3 dB step size	
	Lower	Upper	Lower	Upper	Lower	Upper
+ 1	+0.5	+1.5	+1	+3	+1.5	+4.5
0	-0.5	+0.5	-0.5	+0.5	-0.5	+0.5
- 1	-0.5	-1.5	-1	-3	-1.5	-4.5
+1 at or above max power threshold	-0.5	+1.5	-0.5	+3	-0.5	+4.5
-1 at or below min power threshold	+0.5	-1.5	+0.5	-3	+0.5	-4.5

~~NOTE: The requirements for TPC_cmd = +1 at or above max power threshold and for TPC_cmd = -1 at or below min power threshold are included to avoid ambiguity in the required test behaviour. These requirements are not explicitly included in [1] but are consistent with [1] and [5].~~

Table 5.4.2.2: Transmitter average power control tolerance

TPC_cmd group	Transmitter power control range after 10 equal TPC_cmd group (all units are in dB)				Transmitter power control range after 7 equal TPC_cmd groups (all units are in dB)	
	1 dB step size		2 dB step size		3 dB step size	
	Lower	Upper	Lower	Upper	Lower	Upper
+ 1	+8	+12	+16	+24	+16	+26
0	-1	+1	-1	+1	-1	+1
- 1	-8	-12	-16	-24	-16	-26
0,0,0,0,+1	+6	+14	N/A	N/A	N/A	N/A
0,0,0,0,-1	-6	-14	N/A	N/A	N/A	N/A

NOTE 1: 3dB inner loop power control steps are only used in compressed mode.

The reference for this requirement is [1] TS 25.101 subclause 6.4.2.1.1.

The requirements for the derivation of TPC_cmd are detailed in TS 25.214 subclauses 5.1.2.2.2 and 5.1.2.2.3.

5.4.2.3 Test purpose

- To verify that the UE inner loop power control size and response is meet to the described value shown in subclause 5.4.2.2.
- To verify that TPC_cmd is correctly derived from received TPC commands.

An excess error of the inner loop power control decreases the system capacity.

The UE shall be tested for the requirements for inner loop power control over the power range bounded by the Min power threshold for test and the Max power threshold for test.

The Min power threshold for test is defined as the Minimum Output Power Test Requirement (subclause 5.4.3.5).

The Max power threshold for test is defined as the Maximum output power of the UE (as measured in subclause 5.2.4.2 step 2) minus the Test Tolerance specified for test 5.2 Maximum Output Power in table F.2.1.

For the final power step adjacent to the Min or Max power threshold for test, the lower step size requirement does not apply.

5.4.2.4 Method of test

5.4.2.4.1 Initial conditions

- 1) Connect the SS to the UE antenna connector as shown in Figure A.1.
- 2) A call is set up according to the Generic call setup procedure. The Uplink DPCH Power Control Info shall specify the Power Control Algorithm as algorithm 2 for interpreting TPC commands.
- 3) Enter the UE into loopback test mode and start the loopback test.

See [3] TS 34.108 and [4] TS 34.109 for details regarding generic call setup procedure and loopback test.

5.4.2.4.2

Procedure

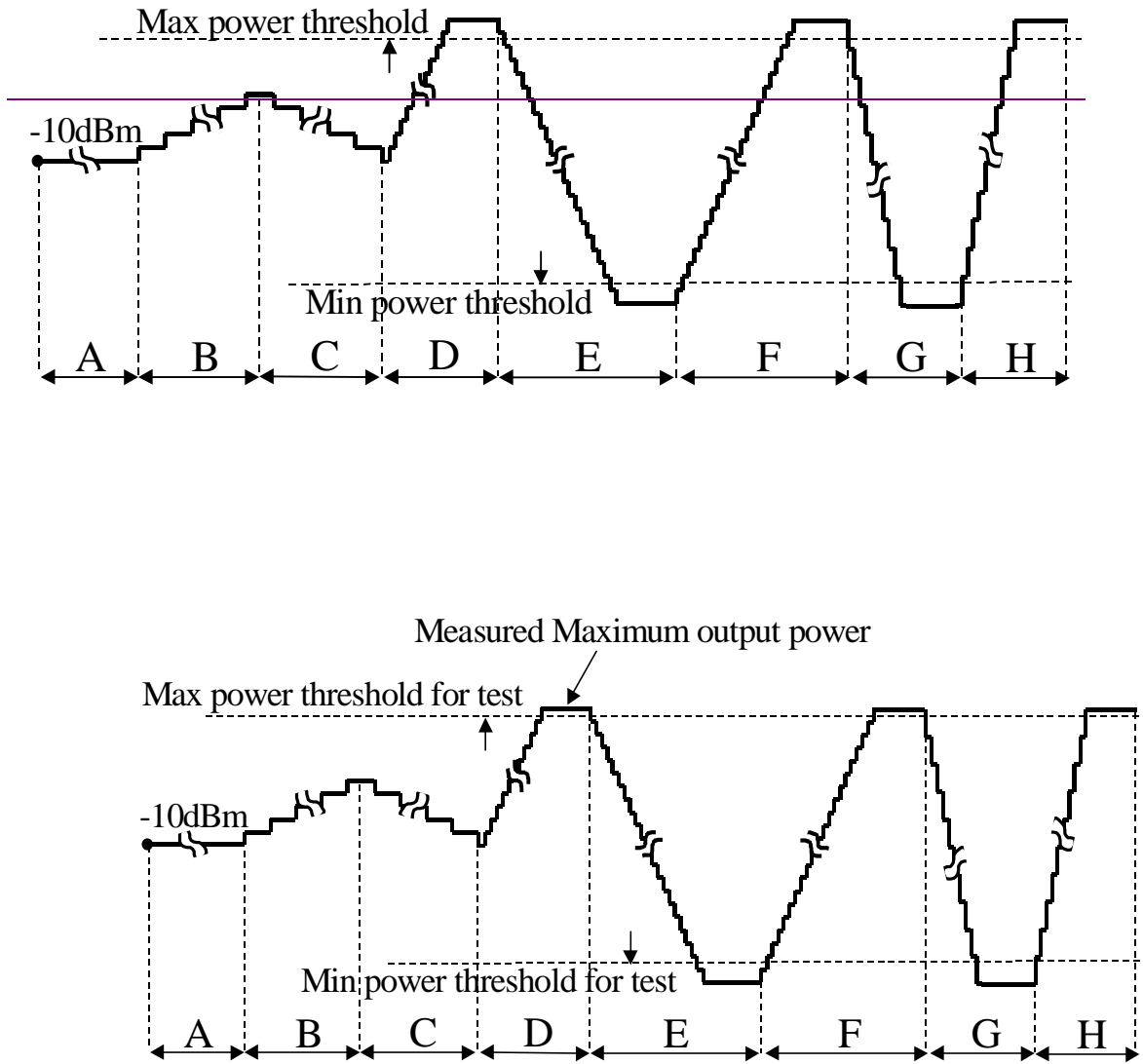

Figure 5.4.2.4 Inner Loop Power Control Test Steps

- 1) Before proceeding with paragraph (2) (Step A) below, set the output power of the UE, measured at the UE antenna connector, to be in the range -10 ± 9 dBm. This may be achieved by setting the downlink signal (\hat{I}_{or}) to yield an appropriate open loop output power and/or by generating suitable downlink TPC commands from the SS.

- 2) Step A: Transmit a sequence of at least 30 and no more than 60 TPC commands, which shall commence at a frame boundary and last for a whole number of frames, and which shall contain:
- no sets of 5 consecutive “0” or “1” commands which commence in the 1st, 6th or 11th slots of a frame;
 - at least one set of 5 consecutive “0” commands which does not commence in the 1st, 6th or 11th slots of a frame;
 - at least one set of 5 consecutive “1” commands which does not commence in the 1st, 6th or 11th slots of a frame.

The following is an example of a suitable sequence of TPC commands:

100001010101011111010000101010101111101000010101010111110

- 3) Step B: Transmit a sequence of 50 TPC commands with the value 1.
- 4) Step C: Transmit a sequence of 50 TPC commands with the value 0.
- 5) Step D: Reconfigure the uplink channel to set the Power Control Algorithm to algorithm 1, and the TPC step size to 1 dB. When the reconfiguration is complete, transmit a sequence of TPC commands with the value 1 until the UE output power is above the maximum power threshold.
- 6) Step E: Transmit a sequence of 150¹ TPC commands with the value 0.
- 7) Step F: Transmit a sequence of 150¹ TPC commands with the value 1.
- 8) Step G: Reconfigure the uplink channel to set the TPC step size to 2 dB (with the Power Control Algorithm remaining as algorithm 1). When the reconfiguration is complete, transmit a sequence of TPC commands with the value 1 until the UE output power is above the maximum power threshold. Transmit a sequence of 75¹ TPC commands with the value 0.
- 9) Step H: Transmit a sequence of 75¹ TPC commands with the value 1.
- 10) During steps A to H the mean output power of every slot shall be measured, with the following exceptions:
- In steps D and F, measurement of the output power is not required in slots after the 10th slot after the mean output power has exceeded the maximum power threshold;
 - In steps E and G, measurement of the output power is not required in slots after the 10th slot after the mean output power has fallen below the minimum power threshold.

The transient periods of 25µs before each slot boundary and 25µs after each slot boundary shall not be included in the power measurements.

¹ NOTE: These numbers of TPC commands are given as examples. The actual number of TPC commands transmitted in these steps shall be at least 10 more than the number required to ensure that the UE reaches the relevant maximum or minimum power threshold in each step, as shown in Figure 5.4.2.4.

5.4.2.5 Test requirements

- a) During Step A, the difference in mean output power between adjacent slots shall be within the prescribed range for a TPC_cmd of 0, as given in Table 5.4.2.1.
- b) During Step A, the change in mean output power over 10 consecutive slots shall be within the prescribed range for a TPC_cmd group of 0, as given in Table 5.4.2.2.
- c) During Step B, the difference in mean output power between adjacent slots shall be within the prescribed range given in Table 5.4.2.1, given that every 5th TPC_cmd should have the value + 1, with a step size of 1 dB, and all other TPC_cmd should have the value 0.
- d) During Step B, the change in mean output power over 50 consecutive slots shall be within the prescribed range for a TPC_cmd group of {0,0,0,0,+1}, as given in Table 5.4.2.2.

- e) During Step C, the difference in mean output power between adjacent slots shall be within the prescribed range given in Table 5.4.2.1, given that every 5th TPC_cmd should have the value -1 , with a step size of 1 dB, and all other TPC_cmd should have the value 0.
- f) During Step C, the change in mean output power over 50 consecutive slots shall be within the prescribed range for a TPC_cmd group of $\{0,0,0,0,-1\}$, as given in Table 5.4.2.2.
- g) During Step E, the difference in mean output power between adjacent slots shall be within the prescribed range given in Table 5.4.2.1 for a TPC_cmd of -1 and step size of 1 dB. This applies when the original (reference) timeslot power and the target timeslot power are between the Min power threshold for test and the Max power threshold for test. For the power step adjacent to the Min or Max power threshold for test, the lower step size requirement does not apply, until the output power reaches (Minimum power threshold + 0.5 dB). When the output power is between the values of (Minimum power threshold + 0.5 dB) and (Minimum power threshold), the difference in mean output power between adjacent slots shall be at least sufficient to decrease the output power to the Minimum power threshold, but shall not exceed -1.5 dB. Once the output power is at or below the Minimum power threshold, the relevant condition in Table 5.4.2.1 shall be met.
- h) During Step E, the change in mean output power over 10 consecutive slots shall be within the prescribed range for a TPC_cmd group of -1 , and step size of 1 dB as given in Table 5.4.2.2. This applies when the original (reference) timeslot power and the target timeslot power are between the Min power threshold for test and the Max power threshold for test. The power step adjacent to the Min or Max power threshold for test should not be part of the 10 consecutive slots tested, until the output power reaches (Minimum power threshold + 0.5 dB).
- i) During Step F, the difference in mean output power between adjacent slots shall be within the prescribed range given in Table 5.4.2.1 for a TPC_cmd of $+1$ and step size of 1 dB. This applies when the original (reference) timeslot power and the target timeslot power are between the Min power threshold for test and the Max power threshold for test. For the power step adjacent to the Min or Max power threshold for test, the lower step size requirement does not apply, until the output power reaches (Maximum power threshold -0.5 dB). When the output power is between the values of (Maximum power threshold -0.5 dB) and (Maximum power threshold), the difference in mean output power between adjacent slots shall be at least sufficient to increase the output power to the Maximum power threshold, but shall not exceed $+1.5$ dB. Once the output power is at or above the Maximum power threshold, the relevant condition in Table 5.4.2.1 shall be met.
- j) During Step F, the change in mean output power over 10 consecutive slots shall be within the prescribed range for a TPC_cmd group of $+1$, and step size of 1 dB as given in Table 5.4.2.2. This applies when the original (reference) timeslot power and the target timeslot power are between the Min power threshold for test and the Max power threshold for test. The power step adjacent to the Min or Max power threshold for test should not be part of the 10 consecutive slots tested, until the output power reaches (Maximum power threshold -0.5 dB).
- k) During Step G, the difference in mean output power between adjacent slots shall be within the prescribed range given in Table 5.4.2.1 for a TPC_cmd of -1 and step size of 2 dB. This applies when the original (reference) timeslot power and the target timeslot power are between the Min power threshold for test and the Max power threshold for test. For the power step adjacent to the Min or Max power threshold for test, the lower step size requirement does not apply, until the output power reaches (Minimum power threshold + 1 dB). When the output power is between the values of (Minimum power threshold + 1 dB) and (Minimum power threshold), the difference in mean output power between adjacent slots shall be at least sufficient to decrease the output power to the Minimum power threshold, but shall not exceed -3 dB. Once the output power is at or below the Minimum power threshold, the relevant condition in Table 5.4.2.1 shall be met.
- l) During Step G, the change in mean output power over 10 consecutive slots shall be within the prescribed range for a TPC_cmd group of -1 , and step size of 2 dB as given in Table 5.4.2.2. This applies when the original (reference) timeslot power and the target timeslot power are between the Min power threshold for test and the Max power threshold for test. The power step adjacent to the Min or Max power threshold for test should not be part of the 10 consecutive slots, until the output power reaches (Minimum power threshold + 1 dB).

- m) During Step H, the difference in mean output power between adjacent slots shall be within the prescribed range given in Table 5.4.2.1 for a TPC_cmd of + 1 and step size of 2 dB. This applies when the original (reference) timeslot power and the target timeslot power are between the Min power threshold for test and the Max power threshold for test. For the power step adjacent to the Min or Max power threshold for test, the lower step size requirement does not apply, until the output power reaches (Maximum power threshold – 1 dB). When the output power is between the values of (Maximum power threshold – 1 dB) and (Maximum power threshold), the difference in mean output power between adjacent slots shall be at least sufficient to increase the output power to the Maximum power threshold, but shall not exceed + 3 dB. Once the output power is at or above the Maximum power threshold, the relevant condition in Table 5.4.2.1 shall be met.
- n) During Step H, the change in mean output power over 10 consecutive slots shall be within the prescribed range for a TPC_cmd group of + 1, and step size of 2 dB as given in Table 5.4.2.2. This applies when the original (reference) timeslot power and the target timeslot power are between the Min power threshold for test and the Max power threshold for test. The power step adjacent to the Min or Max power threshold for test should not be part of the 10 consecutive slots tested, until the output power reaches (Maximum power threshold – 1 dB).

CHANGE REQUEST

⌘ **TS34.121 CR 095** ⌘ rev **-** ⌘ Current version: **3.4.0** ⌘

For **HELP** on using this form, see bottom of this page or look at the pop-up text over the ⌘ symbols.

Proposed change affects: ⌘ (U)SIM ME/UE Radio Access Network Core Network

Title:	⌘	Removal of Annex-I	
Source:	⌘	T1/RF	
Work item code:	⌘		Date: ⌘ 15/May/2001
Category:	⌘	D	Release: ⌘ R99
		<p>Use <u>one</u> of the following categories:</p> <p>F (essential correction)</p> <p>A (corresponds to a correction in an earlier release)</p> <p>B (Addition of feature),</p> <p>C (Functional modification of feature)</p> <p>D (Editorial modification)</p> <p>Detailed explanations of the above categories can be found in 3GPP TR 21.900.</p>	<p>Use <u>one</u> of the following releases:</p> <p>2 (GSM Phase 2)</p> <p>R96 (Release 1996)</p> <p>R97 (Release 1997)</p> <p>R98 (Release 1998)</p> <p>R99 (Release 1999)</p> <p>REL-4 (Release 4)</p> <p>REL-5 (Release 5)</p>

Reason for change:	⌘	In T1/RF #18 meeting, it was agreed that Annex-I is no more needed.
Summary of change:	⌘	Remove all of contents in Annex-I, and Annex-I is kept as (void).
Consequences if not approved:	⌘	Needless Annex remains.

Clauses affected:	⌘	Annex-I
Other specs affected:	⌘	<input type="checkbox"/> Other core specifications <input type="checkbox"/> Test specifications <input type="checkbox"/> O&M Specifications
Other comments:	⌘	

How to create CRs using this form:

Comprehensive information and tips about how to create CRs can be found at: http://www.3gpp.org/3G_Specs/CRs.htm. Below is a brief summary:

- 1) Fill out the above form. The symbols above marked ⌘ contain pop-up help information about the field that they are closest to.
- 2) Obtain the latest version for the release of the specification to which the change is proposed. Use the MS Word "revision marks" feature (also known as "track changes") when making the changes. All 3GPP specifications can be downloaded from the 3GPP server under <ftp://www.3gpp.org/specs/> For the latest version, look for the directory name with the latest date e.g. 2000-09 contains the specifications resulting from the September 2000 TSG meetings.
- 3) With "track changes" disabled, paste the entire CR form (use CTRL-A to select it) into the specification just in front of the clause containing the first piece of changed text. Delete those parts of the specification which are not relevant to the change request.

~~Annex I (informative): (Void)~~ ~~Test cases requiring evaluation for applicability~~

~~I.1 General~~

~~This annex contains test cases that were removed from 34.121 V3.2.0 (2000-09), clause 8 when it was restructured according to core requirements in 25.133 V3.3.0 (2000-09). The test cases were left out because no corresponding core requirement existed. This, however, does not mean that there will not be any corresponding core requirements in future versions of 25.133. Therefore, to preserve the content for future enhancements, it has been decided to move these test specifications to this annex.~~

~~I.2 Synchronization performance~~

~~8.5.1 Synchronization performance~~

~~8.5.1.1 Search of other Cells~~

~~8.5.1.1.1 Definition and applicability~~

~~Search for other cells is used to check whether the UE correctly searches and measures other BS(s) during the specified operation:~~

~~<Editor's Note: The applicability for this test whether it is mandatory or not should be clarified.>~~

~~8.5.1.1.2 Conformance requirements~~

~~[TBD]~~

Table 8.5.1.1.1: Test Parameters for the Search of other Cells

Parameter	Channel 1		Channel 2		Unit
	Time 1	Time 2	Time 1	Time 2	
$P_{CCPCH} \frac{E_c}{I_{or}}$					dB
\hat{I}_{or}/I_{oc}					dB
I_{oc}	-60				dBm / 3.84 MHz
$P_{CCPCH} \frac{E_c}{I_o}$					dB

~~The reference for this requirement is [2] TS 25.133 subclause 7.1.1.1.~~

~~8.5.1.1.3 Test purpose~~

~~[TBD]~~

~~8.5.1.1.4 Method of test~~

~~The measuring configuration is shown in Figure A.9.~~

~~8.5.1.1.4.1 Initial conditions~~

~~[TBD]~~

~~8.5.1.1.4.2~~ Procedures

- ~~1. Setup the equipment as shown in Figure A.11 (without fading channel blocks).~~
- ~~2. Set the test parameters as specified in Table 8.5.1.1.1.~~
- ~~3. Turn UE on.~~
- ~~4. TBD~~

~~8.5.1.1.5~~ Test requirements

~~{TBD}~~

~~1.3~~ Reception timing

~~8.5.4~~ Reception Timing

~~8.5.4.1~~ Definition and applicability

The reception timing of the UE is determined during the specified operation.

~~<Editor's Note: The applicability for this test whether it is mandatory or not should be clarified.>~~

~~8.5.4.2~~ Conformance requirements

~~{TBD}~~

The reference for this requirement is [2] TS 25.133 subclause 7.4.1.

~~8.5.4.3~~ Test purpose

~~{TBD}~~

~~8.5.4.4~~ Method of test

The measuring configuration is shown in Figure A.9.

~~8.5.4.4.1~~ Initial conditions

~~{TBD}~~

~~8.5.4.4.2~~ Procedures

~~{TBD}~~

~~8.5.4.5~~ Test requirements

~~{TBD}~~

CHANGE REQUEST

⌘ **34.121 CR 096** ⌘ rev **-** ⌘ Current version: **3.4.0** ⌘

For **HELP** on using this form, see bottom of this page or look at the pop-up text over the ⌘ symbols.

Proposed change affects: ⌘ (U)SIM ME/UE Radio Access Network Core Network

Title:	⌘	Correction of downlink signal conditions for out-of-synchronization handling of output power	
Source:	⌘	T1/RF	
Work item code:	⌘		Date: ⌘ May 15, 2001
Category:	⌘	F	Release: ⌘ R99
		<p><i>Use one of the following categories:</i></p> <p>F (essential correction) A (corresponds to a correction in an earlier release) B (Addition of feature), C (Functional modification of feature) D (Editorial modification)</p> <p>Detailed explanations of the above categories can be found in 3GPP TR 21.900.</p>	<p><i>Use one of the following releases:</i></p> <p>2 (GSM Phase 2) R96 (Release 1996) R97 (Release 1997) R98 (Release 1998) R99 (Release 1999) REL-4 (Release 4) REL-5 (Release 5)</p>

Reason for change:	⌘	The downlink signal condition is not well defined in Annex-E for this test.
Summary of change:	⌘	"Method of test" in this test is modified to refer to Annex-E.3.3. And the description in E.3.3 is modified.
Consequences if not approved:	⌘	The downlink signal remains ambiguous in test specification.

Clauses affected:	⌘	5.4.4.4, Annex-E.3.3
Other specs affected:	⌘	<input type="checkbox"/> Other core specifications ⌘ <input type="checkbox"/> Test specifications ⌘ <input type="checkbox"/> O&M Specifications ⌘
Other comments:	⌘	

How to create CRs using this form:

Comprehensive information and tips about how to create CRs can be found at: http://www.3gpp.org/3G_Specs/CRs.htm. Below is a brief summary:

- 1) Fill out the above form. The symbols above marked ⌘ contain pop-up help information about the field that they are closest to.
- 2) Obtain the latest version for the release of the specification to which the change is proposed. Use the MS Word "revision marks" feature (also known as "track changes") when making the changes. All 3GPP specifications can be downloaded from the 3GPP server under <ftp://www.3gpp.org/specs/> For the latest version, look for the directory name with the latest date e.g. 2000-09 contains the specifications resulting from the September 2000 TSG meetings.
- 3) With "track changes" disabled, paste the entire CR form (use CTRL-A to select it) into the specification just in front of the clause containing the first piece of changed text. Delete those parts of the specification which are not relevant to the change request.

5.4.4 Out-of-synchronisation handling of output power

5.4.4.1 Definition and applicability

The UE shall monitor the DPCCH quality in order to detect a loss of the signal on Layer 1, as specified in [5] TS 25.214. The thresholds Q_{out} and Q_{in} specify at what DPCCH quality levels the UE shall shut its power off and when it shall turn its power on respectively. The thresholds are not defined explicitly, but are defined by the conditions under which the UE shall shut its transmitter off and turn it on, as stated in this subclause.

5.4.4.2 Minimum Requirements

The parameters in Table 5.4.4.1 are defined using the DL reference measurement channel (12.2 kbps) specified in Annex C.3.1 and with static propagation conditions.

Table 5.4.4.1: DCH parameters for test of Out-of-synch handling

Parameter	Value	Unit
\hat{I}_{or}/I_{oc}	-1	dB
I_{oc}	-60	dBm / 3.84 MHz
$\frac{DPDCH_E_c}{I_{or}}$	See Figure 5.4.4.1: Before point A -16.6 After point A Not defined ¹⁾	dB
$\frac{DPCCH_E_c}{I_{or}}$	See Table 5.4.4.2	dB
Information Data Rate	12.2	kbps
TFCI	on	-

Table 5.4.4.2: Minimum Requirements for DPCCH_Ec/Ior levels

Section from figure 5.4.4.1	DPCCH_Ec/Ior	Unit
Before A	-16.6	dB
A to B	-22.0	dB
B to D	-28.0	dB
D to E	-24.0	dB
After E	-18.0	dB

The conditions for when the UE shall shut its transmitter off and when it shall turn it on are defined by the parameters in Table 5.4.4.1 and Table 5.4.4.2.

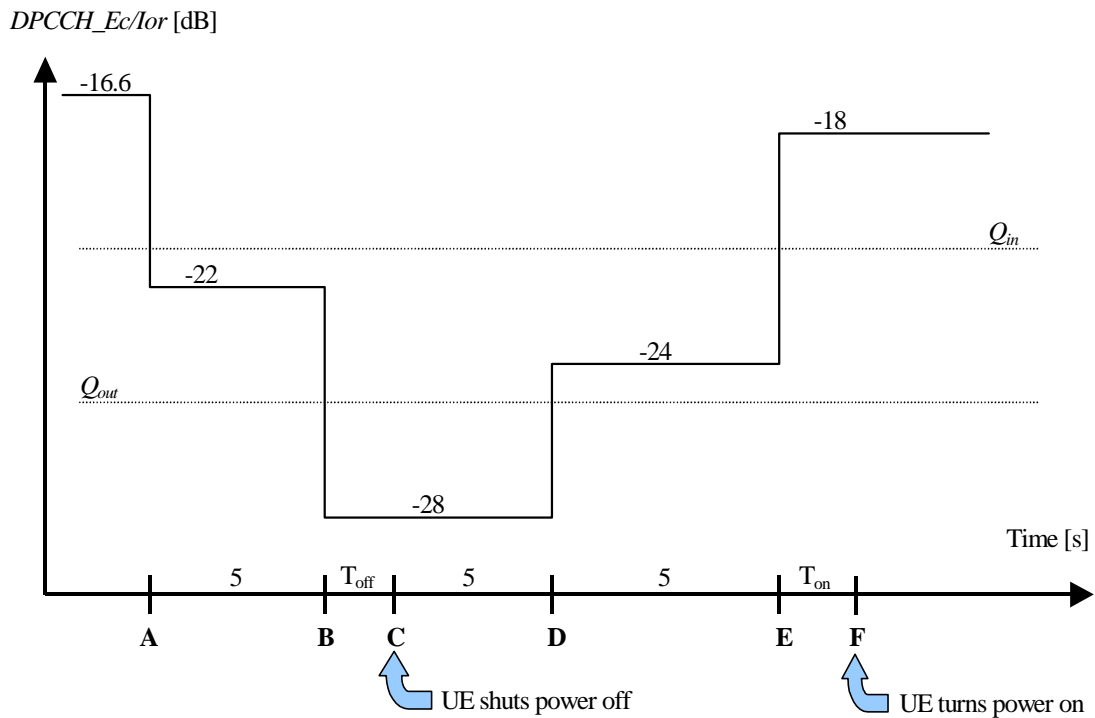

Figure 5.4.4.1: Conditions for out-of-synch handling in the UE. The indicated thresholds Q_{out} and Q_{in} are only informative.

The requirements for the UE are that

1. The UE shall not shut its transmitter off before point B.
2. The UE shall shut its transmitter off before point C, which is $T_{off} = 200$ ms after point B.
3. The UE shall not turn its transmitter on between points C and E.
4. The UE shall turn its transmitter on before point F, which is $T_{on} = 200$ ms after point E.

The normative reference for this requirement is [1] TS 25.101 subclause 6.4.4.1.

5.4.4.3 Test purpose

To verify that the UE monitors the DPCCH quality and turns its transmitter on or off according to DPCCH level diagram specified in Figure 5.4.4.1.

NOTE 1: DPDCH E_c/I_{or} after point A is not defined in Table 5.4.4.1. However it is assumed that DPDCH and DPCCH power level are same on DL 12.2kbps reference measurement channel for testing. (PO1, PO2, and PO3 are zero.)

5.4.4.4 Method of test

5.4.4.4.1 Initial conditions

- 1) Connect the SS to the UE antenna connector as shown in Figure A.1.
- 2) A call is set up according to the Generic call setup procedure, and DCH parameters are set up according to Table 5.4.4.1 with DPCCH E_c/I_{or} ratio level at -16.6 dB. The other RF parameters are set up according to Annex E.3.34.
- 3) Enter the UE into loopback test mode and start the loopback test.

See [3] TS 34.108 and [4] TS 34.109 for details regarding generic call setup procedure and loopback test.

5.4.4.4.2 Procedure

- 1) The SS sends continuously Up power control commands to the UE until the UE transmitter power reach maximum level.
- 2) The SS controls the DPCCH_Ec/Ior ratio level according to section 'A to B' as defined in Table 5.4.4.3. The SS monitors the UE transmitted power for 5 seconds and verifies that the UE transmitter is not switched off during this time.
- 3) The SS controls the DPCCH_Ec/Ior ratio level according to section 'B to D' as defined in Table 5.4.4.3. The SS waits 200 ms and then verifies that the UE transmitter has been switched off.
- 4) The SS monitors the UE transmitted power for 5 seconds and verifies that the UE transmitter is not switched on during this time.
- 5) The SS controls the DPCCH_Ec/Ior ratio level according to section 'E to F' as defined in Table 5.4.4.3. The SS monitors the UE transmitted power for 5 seconds and verifies that the UE transmitter is not switched on during this time.
- 6) The SS controls the DPCCH_Ec/Ior ratio level according to section 'After F' as defined in Table 5.4.4.3. The SS waits 200 ms and then verifies that the UE transmitter has been switched on.

5.4.4.5 Test requirements

Table 5.4.4.3: Test Requirements for DPCCH_Ec/Ior levels

Section from figure 5.4.4.1	DPCCH_Ec/Ior	Unit
Before A	-16.6	dB
A to B	-[21.7]	dB
B to D	-[28.3]	dB
D to E	-[24.3]	dB
After E	-[17.7]	dB

To pass the test, steps 1 through 6 of the procedure in 5.4.4.4.2 must be fulfilled.

The UE transmitter off criterion and its tolerances is defined in subclause 5.5.1 (Transmit off power)

The UE transmitter on criterion and its tolerances is defined in subclause 5.4.3 (Minimum Output Power). The UE transmitter is considered to be on if the UE transmitted power is higher than minimum output power.

NOTE: If the above Test Requirement differs from the Minimum Requirement then the Test Tolerance applied for this test is non-zero. The Test Tolerance for this test is defined in Annex F.2 and the explanation of how the Test Requirement has been relaxed by the Test Tolerance is given in Annex F.4.

E.3.3 Measurement of Performance requirements

Table E.3.3 is applicable for measurements on the Performance requirements (clause 7), including subclause 6.3 (Maximum input level) and 5.4.4 (Out-of-synchronisation handling of output power), excluding subclauses 7.6.1 (Demodulation of DCH in open loop transmit diversity mode) and 7.6.2 (Demodulation of DCH in closed loop transmit diversity mode).

Table E.3.3: Downlink Physical Channels transmitted during a connection¹

Physical Channel	Power	Note
P-CPICH	$P\text{-CPICH}_{Ec/Ior} = -10 \text{ dB}$	Use of P-CPICH or S-CPICH as phase reference is specified for each requirement and is also set by higher layer signalling.
S-CPICH	$S\text{-CPICH}_{Ec/Ior} = -10 \text{ dB}$	When S-CPICH is the phase reference in a test condition, the phase of S-CPICH shall be 180 degrees offset from the phase of P-CPICH. When S-CPICH is not the phase reference, it is not transmitted.
P-CCPCH	$P\text{-CCPCH}_{Ec/Ior} = -12 \text{ dB}$	
SCH	$SCH_{Ec/Ior} = -12 \text{ dB}$	This power shall be divided equally between Primary and Secondary Synchronous channels
PICH	$PICH_{Ec/Ior} = -15 \text{ dB}$	
DPCH	Test dependent power	When S-CPICH is the phase reference in a test condition, the phase of DPCH shall be 180 degrees offset from the phase of P-CPICH.
OCNS	Necessary power so that total transmit power spectral density of Node B (I_{oc}) adds to one	OCNS interference consists of 16 dedicated data channels. The channelization codes, level settings and timing offsets for data channels are chosen as specified for the 16 DPCH channels of Test Model 1 in TS 25.141 [10] Table 6.2. All dedicated channels user data is uncorrelated to each other and the measurement channel during the BER/BLER measurement period.

¹ Power levels are based on the assumption that multipath propagation conditions and noise source representing interference from other cells I_{oc} are turned on after the call set-up phase.

CR-Form-v3

CHANGE REQUEST

⌘ **34.121 CR 097** ⌘ rev **-** ⌘ Current version: **3.4.0** ⌘

For **HELP** on using this form, see bottom of this page or look at the pop-up text over the ⌘ symbols.

Proposed change affects: ⌘ (U)SIM ME/UE Radio Access Network Core Network

Title:	⌘ Corrections to TS34.121		
Source:	⌘ T1/RF		
Work item code:	⌘	Date:	⌘ 16-May-2001
Category:	⌘ F	Release:	⌘ R99
	Use <u>one</u> of the following categories: F (essential correction) A (corresponds to a correction in an earlier release) B (Addition of feature), C (Functional modification of feature) D (Editorial modification) Detailed explanations of the above categories can be found in 3GPP TR 21.900.		Use <u>one</u> of the following releases: 2 (GSM Phase 2) R96 (Release 1996) R97 (Release 1997) R98 (Release 1998) R99 (Release 1999) REL-4 (Release 4) REL-5 (Release 5)

Reason for change:	⌘ To reflect changes in the core specification
Summary of change:	⌘ Some requirements need to be band specific. Some informative notes should be normative. The range of UARFCN is specified for each paired band. Changes are based on 25.101CR89 and CR94.
Consequences if not approved:	⌘ Test requirement remains inconsistent with its core specification.

Clauses affected:	⌘ 4.3, 4.4.3, 4.4.4, 5.9.2, 5.9.5, 5.11.2, 5.11.5, 6.5.2, 6.5.5, 6.8.2, 6.8.5		
Other specs affected:	<input type="checkbox"/> Other core specifications <input type="checkbox"/> Test specifications <input type="checkbox"/> O&M Specifications	⌘	
Other comments:	⌘		

How to create CRs using this form:

Comprehensive information and tips about how to create CRs can be found at: http://www.3gpp.org/3G_Specs/CRs.htm. Below is a brief summary:

- 1) Fill out the above form. The symbols above marked ⌘ contain pop-up help information about the field that they are closest to.
- 2) Obtain the latest version for the release of the specification to which the change is proposed. Use the MS Word "revision marks" feature (also known as "track changes") when making the changes. All 3GPP specifications can be downloaded from the 3GPP server under <ftp://www.3gpp.org/specs/> For the latest version, look for the directory name with the latest date e.g. 2000-09 contains the specifications resulting from the September 2000 TSG meetings.
- 3) With "track changes" disabled, paste the entire CR form (use CTRL-A to select it) into the specification just in front of the clause containing the first piece of changed text. Delete those parts of the specification which are not relevant to the change request.

4 Frequency bands and channel arrangement

4.1 General

The information presented in this clause is based on a chip rate of 3.1 Mcps.

NOTE: Other chip rates may be considered in future releases.

4.2 Frequency bands

UTRA/FDD is designed to operate in either of the following paired bands;

- (a) 1920 – 1980MHz: Up-link (Mobile transmit, base receive)
2110 – 2170MHz: Down-link (Base transmit, mobile receive)
- (b)* 1850 – 1910MHz: Up-link (Mobile transmit, base receive)
1930 – 1990MHz: Down-link (Base transmit, mobile receive)

* Used in Region 2.

Additional allocations in ITU region 2 are FFS.

Deployment in other frequency bands is not precluded.

4.3 TX–RX frequency separation

- a) UTRA/FDD is designed to operate with the following TX-RX frequency separation

<u>Frequency Band</u>	<u>TX-RX frequency separation</u>
<u>For operation in frequency band as defined in subclause 4.2 (a)</u>	<u>190 MHz</u>
<u>For operation in frequency band as defined in subclause 4.2 (b)</u>	<u>80 MHz.</u>

~~The minimum transmit to receive frequency separation is 134.8 MHz and the maximum value is 245.2 MHz and all UE(s) shall support a TX–RX frequency separation of 190 MHz when operating in the paired band defined in subclause 4.2 (a).~~

~~b) When operating in the paired band defined in subclause 4.2 (b), all UE(s) shall support a TX–RX frequency separation of 80 MHz.~~

~~e) UTRA/FDD can support both fixed and variable transmit to receive frequency separation.~~

~~d) The use of other transmit to receive frequency separations in existing or other frequency bands shall not be precluded.~~

4.4 Channel arrangement

4.4.1 Channel spacing

The nominal channel spacing is 5 MHz, but this can be adjusted to optimise performance in a particular deployment scenario.

4.4.2 Channel raster

The channel raster is 200 kHz, which means that the centre frequency must be an integer multiple of 200 kHz.

4.4.3 Channel number

The carrier frequency is designated by the UTRA Absolute Radio Frequency Channel Number (UARFCN). The values of the UARFCN ~~in the IMT-2000 band is defined~~ are as follows;

Table 4.1: UTRA Absolute Radio Frequency Channel Number UARFCN definition

Uplink	$N_u = 5 * F_{\text{uplink}}$	$0.0 \text{ MHz} \leq F_{\text{uplink}} \leq 3276.6 \text{ MHz}$ where F_{uplink} is the uplink frequency in MHz
Downlink	$N_d = 5 * F_{\text{downlink}}$	$0.0 \text{ MHz} \leq F_{\text{downlink}} \leq 3276.6 \text{ MHz}$ where F_{downlink} is the downlink frequency in MHz

4.4.4 UARFCN

The following UARFCN range shall be supported for each paired band

Table 4.2: UTRA Absolute Radio Frequency Channel Number

Frequency Band	Uplink UE transmit, Node B receive	Downlink UE receive, Node B transmit
For operation in frequency band as defined in subclause 4.2 (a)	9612 to 9888	10562 to 10838
For operation in frequency band as defined in subclause 4.2 (b)	9262 to 9538	9662 to 9938

5.9 Spectrum emission mask

5.9.1 Definition and applicability

The spectrum emission mask of the UE applies to frequencies, which are between 2.5 MHz and 12.5 MHz away from the UE centre carrier frequency. The out of channel emission is specified relative to the UE output power measured in a 3.84 MHz bandwidth.

The requirements and this test apply to all types of UTRA for the FDD UE.

5.9.2 Minimum Requirements

The power of any UE emission shall not exceed the levels specified in Table 5.9.1.

Table 5.9.1: Spectrum Emission Mask Requirement

Frequency offset from carrier Δf	Minimum requirement	Measurement bandwidth
2.5 - 3.5 MHz	$-35 - 15 * (\Delta f - 2.5) \text{ dBc}$	30 kHz *
3.5 - 7.5 MHz	$-35 - 1 * (\Delta f - 3.5) \text{ dBc}$	1 MHz **
7.5 - 8.5 MHz	$-39 - 10 * (\Delta f - 7.5) \text{ dBc}$	1 MHz **
8.5 - 12.5 MHz	-49 dBc	1 MHz **
* The first and last measurement position with a 30 kHz filter is 2.515 MHz and 3.485 MHz.		
** The first and last measurement position with a 1 MHz filter is 4 MHz and 12 MHz. As a general rule, the resolution bandwidth of the measuring equipment should be equal to the measurement bandwidth. To improve measurement accuracy, sensitivity and efficiency, the resolution bandwidth can be different from the measurement bandwidth. When the resolution bandwidth is smaller than the measurement bandwidth, the result should be integrated over the measurement bandwidth.		
The lower limit shall be -50 dBm/3.84 MHz or which ever is higher.		

NOTE*:

1. The first and last measurement position with a 30 kHz filter is 2.515 MHz and 3.485 MHz.
2. The first and last measurement position with a 1 MHz filter is 4 MHz and 12 MHz. As a general rule, the resolution bandwidth of the measuring equipment should be equal to the measurement bandwidth. To improve measurement accuracy, sensitivity and efficiency, the resolution bandwidth can be different from the measurement bandwidth. When the resolution bandwidth is smaller than the measurement bandwidth, the result should be integrated over the measurement bandwidth.

~~3. The lower limit shall be $-50 \text{ dBm} / 3.84 \text{ MHz}$ or which ever is higher.~~

The normative reference for this requirement is [1] TS 25.101 subclause 6.6.2.1.1.

5.9.3 Test purpose

To verify that the power of UE emission does not exceed the prescribed limits shown in Table 5.9.1. Excess emission increases the interference to other channels or to other systems.

5.9.4 Method of test

5.9.4.1 Initial conditions

- 1) Connect the SS to the UE antenna connector as shown in Figure A.1.
- 2) A call is set up according to the Generic call setup procedure.
- 3) Enter the UE into loopback test mode and start the loopback test.

See [3] TS 34.108 and [4] TS 34.109 for details regarding generic call setup procedure and loopback test.

5.9.4.2 Procedure

- 1) Set and send continuously Up power control commands to the UE until the UE output power shall be maximum level.
- 2) Measure the power of the transmitted signal with a measurement filter of bandwidths according to Table 5.9.2. Measurements with an offset from the carrier centre frequency between 2.515 MHz and 3.485 MHz shall use a 30 kHz measurement filter. Measurements with an offset from the carrier centre frequency between 4 MHz and 12 MHz shall use 1 MHz measurement bandwidth and the result may be calculated by integrating multiple 50 kHz or narrower filter measurements. The characteristic of the filter shall be approximately Gaussian (typical spectrum analyzer filter). The centre frequency of the filter shall be stepped in contiguous steps according to Table 5.9.2. The measured power shall be recorded for each step.
- 3) Measure the wanted output power according to Annex B.
- 4) Calculate the ratio of the power 2) with respect to 3) in dBc.

5.9.5 Test requirements

The result of 5.9.4.2 step 4) shall fulfil the requirements of Table 5.9.2.

Table 5.9.2: Spectrum Emission Mask Requirement

Frequency offset from carrier Δf	Minimum requirement	Measurement bandwidth
2.5 - 3.5 MHz	$-33.5 - 15^*(\Delta f - 2.5) \text{ dBc}$	30 kHz *
3.5 - 7.5 MHz	$-33.5 - 1^*(\Delta f - 3.5) \text{ dBc}$	1 MHz **
7.5 - 8.5 MHz	$-37.5 - 10^*(\Delta f - 7.5) \text{ dBc}$	1 MHz **
8.5 - 12.5 MHz	-47.5 dBc	1 MHz **
* <u>The first and last measurement position with a 30 kHz filter is 2.515 MHz and 3.485 MHz.</u>		
** <u>The first and last measurement position with a 1 MHz filter is 4 MHz and 12 MHz. As a general rule, the resolution bandwidth of the measuring equipment should be equal to the measurement bandwidth. To improve measurement accuracy, sensitivity and efficiency, the resolution bandwidth can be different from the measurement bandwidth. When the resolution bandwidth is smaller than the measurement bandwidth, the result should be integrated over the measurement bandwidth.</u>		
<u>The lower limit shall be $-50 \text{ dBm} / 3.84 \text{ MHz}$ or which ever is higher.</u>		

NOTE*:

1. ~~The first and last measurement position with a 30 kHz filter is 2.515 MHz and 3.485 MHz.~~

- ~~2. The first and last measurement position with a 1 MHz filter is 4 MHz and 12 MHz. As a general rule, the resolution bandwidth of the measuring equipment should be equal to the measurement bandwidth. To improve measurement accuracy, sensitivity and efficiency, the resolution bandwidth can be different from the measurement bandwidth. When the resolution bandwidth is smaller than the measurement bandwidth, the result should be integrated over the measurement bandwidth.~~
- ~~3. The lower limit shall be 48.5 dBm / 3.84 MHz or which ever is higher.~~
4. If the above Test Requirement differs from the Minimum Requirement then the Test Tolerance applied for this test is non-zero. The Test Tolerance for this test is defined in Annex F.2 and the explanation of how the Minimum Requirement has been relaxed by the Test Tolerance is given in Annex F.4.

5.11 Spurious Emissions

5.11.1 Definition and applicability

Spurious emissions are emissions which are caused by unwanted transmitter effects such as harmonics emission, parasitic emission, intermodulation products and frequency conversion products, but exclude out of band emissions. The frequency boundary and the detailed transitions of the limits between the requirement for out band emissions and spectrum emissions are based on ITU-R Recommendations SM.329.

The requirements and this test apply to all types of UTRA for the FDD UE.

5.11.2 Minimum Requirements

These requirements are only applicable for frequencies, which are greater than 12.5 MHz away from the UE centre carrier frequency.

Table 5.11.1a: General spurious emissions requirements

Frequency Bandwidth	Resolution Measurement Bandwidth	Minimum requirement
$9 \text{ kHz} \leq f < 150 \text{ kHz}$	1 kHz	-36 dBm
$150 \text{ kHz} \leq f < 30 \text{ MHz}$	10 kHz	-36 dBm
$30 \text{ MHz} \leq f < 1000 \text{ MHz}$	100 kHz	-36 dBm
$1 \text{ GHz} \leq f < 12.75 \text{ GHz}$	1 MHz	-30 dBm

Table 5.11.1b: Additional spurious emissions requirements

Paired band	Frequency Bandwidth	Resolution Measurement Bandwidth	Minimum requirement
For operation in frequency bands as defined in subclause 4.2(a)	$1893.5 \text{ MHz} < f < 1919.6 \text{ MHz}$	300 kHz	-41 dBm
	$925 \text{ MHz} \leq f \leq 935 \text{ MHz}$	100 kHz	-67 dBm *
	$935 \text{ MHz} < f \leq 960 \text{ MHz}$	100 kHz	-79 dBm *
	$1805 \text{ MHz} \leq f \leq 1880 \text{ MHz}$	100 kHz	-71 dBm *
* The measurements are made on frequencies which are integer multiples of 200 kHz. As exceptions, up to five measurements with a level up to the applicable requirements defined in Table 5.11.1a are permitted for each UARFCN used in the measurement			

~~*NOTE: The measurements are made on frequencies which are integer multiples of 200 kHz. As exceptions, up to five measurements with a level up to the applicable requirements defined in Table 5.11.1b are permitted for each UARFCN used in the measurement.~~

The normative reference for this requirement is [1] TS 25.101 subclause 6.6.3.1.

5.11.3 Test purpose

To verify that the UE spurious emissions do not exceed described value shown in Table 5.11.1a and Table 5.11.1b. Excess spurious emissions increase the interference to other systems.

5.11.4 Method of test

5.11.4.1 Initial conditions

- 1) Connect the SS to the UE antenna connector as shown in Figure A.8.
- 2) A call is set up according to the Generic call setup procedure.
- 3) Enter the UE into loopback test mode and start the loopback test.

See [3] TS 34.108 and [4] TS 34.109 for details regarding generic call setup procedure and loopback test.

5.11.4.2 Procedure

- 1) Set and send continuously Up power control commands to the UE until the UE output power shall be maximum level.
- 2) Sweep the spectrum analyzer (or equivalent equipment) over a frequency range and measure the average power of spurious emission.

5.11.5 Test requirements

The measured average power of spurious emission, derived in step 2), shall not exceed the described value in Table 5.11.2a and 5.11.2b.

These requirements are only applicable for frequencies, which are greater than 12.5 MHz away from the UE centre carrier frequency.

Table 5.11.2a: General spurious emissions test requirements

Frequency Bandwidth	Resolution Measurement Bandwidth	Minimum requirement
$9 \text{ kHz} \leq f < 150 \text{ kHz}$	1 kHz	-36 dBm
$150 \text{ kHz} \leq f < 30 \text{ MHz}$	10 kHz	-36 dBm
$30 \text{ MHz} \leq f < 1000 \text{ MHz}$	100 kHz	-36 dBm
$1 \text{ GHz} \leq f < 12.75 \text{ GHz}$	1 MHz	-30 dBm

Table 5.11.2b: Additional spurious emissions test requirements

Paired band	Frequency Bandwidth	Resolution Measurement Bandwidth	Minimum requirement
For operation in frequency bands as defined in subclause 4.2(a)	$1893.5 \text{ MHz} < f < 1919.6 \text{ MHz}$	300 kHz	-41 dBm
	$925 \text{ MHz} \leq f \leq 935 \text{ MHz}$	100 kHz	-67 dBm *
	$935 \text{ MHz} < f \leq 960 \text{ MHz}$	100 kHz	-79 dBm *
	$1805 \text{ MHz} \leq f \leq 1880 \text{ MHz}$	100 kHz	-71 dBm *
* The measurements are made on frequencies which are integer multiples of 200 kHz. As exceptions, up to five measurements with a level up to the applicable requirements defined in Table 5.11.2a are permitted for each UARFCN used in the measurement			

NOTE:

1. The measurements are made on frequencies which are integer multiples of 200 kHz. As exceptions, up to five measurements with a level up to the applicable requirements defined in Table 5.11.2b are permitted for each UARFCN used in the measurement.
2. If the above Test Requirement differs from the Minimum Requirement then the Test Tolerance applied for this test is non-zero. The Test Tolerance for this test is defined in Annex F.2 and the explanation of how the Minimum Requirement has been relaxed by the Test Tolerance is given in Annex F.4.

6.5 Blocking Characteristics

6.5.1 Definition and applicability

The blocking characteristic is a measure of the receiver's ability to receive a wanted signal at its assigned channel frequency in the presence of an unwanted interferer on frequencies other than those of the spurious response or the adjacent channels, without this unwanted input signal causing a degradation of the performance of the receiver beyond a specified limit. The blocking performance shall apply at all frequencies except those at which a spurious response occur.

The requirements and this test apply to all types of UTRA for the FDD UE.

6.5.2 Minimum Requirements

The BER shall not exceed 0.001 for the parameters specified in Table 6.5.1 and Table 6.5.2. For Table 6.5.2 up to (24) exceptions are allowed for spurious response frequencies in each assigned frequency channel when measured using a 1 MHz step size.

The normative reference for this requirement is [1] TS 25.101 subclause 7.6.1.

Note: I_{blocking} (modulated) consists of common channels and 16 dedicated data channels. The channelisation codes for data channels are chosen optimally to reduce peak to average ratio (PAR). All dedicated channels user data is uncorrelated to each other.

Table 6.5.1: Test parameters for In-band blocking characteristics

Parameter	10 MHz offset	15 MHz offset	Unit
DPCH_Ec	-114	-114	dBm / 3.84 MHz
I_{or}	-103.7	-103.7	dBm / 3.84 MHz
I_{blocking} (modulated)	-56	-44	dBm / 3.84 MHz
F_{uw} (offset)	+10 or -10	+15 or -15	MHz

Table 6.5.2: Test parameters for Out of band blocking characteristics

Parameter	Band 1	Band 2	Band 3	Unit
DPCH_Ec	-114	-114	-114	dBm / 3.84MHz
I_{or}	-103.7	-103.7	-103.7	dBm / 3.84MHz
I_{blocking} (CW)	-44	-30	-15	dBm
F_{uw} For operation in frequency bands as defined in subclause 4.2(a)	2050 < f < 2095 2185 < f < 2230	2025 < f < 2050 2230 < f < 2255	1 < f < 2025 2255 < f < 12750	MHz
F_{uw} For operation in frequency bands as defined in subclause 4.2(b)	1870 < f < 1915 2005 < f < 2050	1845 < f < 1870 2050 < f < 2075	1 < f < 1845 2075 < f < 12750	MHz
<u>For operation in bands referenced in 4.2(a), 2095<f<2110 MHz and 2170<f<2185 MHz, the appropriate in-band blocking or adjacent channel selectivity in subclause 6.4 and table 6.5.1 shall be applied.</u>				
<u>For operation in bands referenced in 4.2(b), 1915<f<1930 MHz and 1990<f<2005 MHz, the appropriate in-band blocking or adjacent channel selectivity in subclause 6.4 and table 6.5.1 shall be applied</u>				

NOTE:

1. For operation in bands referenced in 4.2(a), from 2095 < f < 2110 MHz and 2170 < f < 2185 MHz, the appropriate in-band blocking or adjacent channel selectivity in subclause 6.4.2 shall be applied.
2. For operation in bands referenced in 4.2(b), 1915 < f < 1930 MHz and 1990 < f < 2005 MHz, the appropriate in-band blocking or adjacent channel selectivity in subclause 6.4.2 shall be applied.

6.5.3 Test purpose

To verify that the UE BER does not exceed 0.001 for the parameters specified in Table 6.5.1 and Table 6.5.2. For Table 6.5.2 up to (24) exceptions are allowed for spurious response frequencies in each assigned frequency channel when measured using a 1 MHz step size.

The lack of the blocking ability decreases the coverage area when other transmitter exists (except in the adjacent channels and spurious response).

6.5.4 Method of test

6.5.4.1 Initial conditions

- 1) Connect the SS to the UE antenna connector as shown in Figure A.5.
- 2) A call is set up according to the Generic call setup procedure, and RF parameters are set up according to Table 6.5.3 and Table 6.5.4.
- 3) Enter the UE into loopback test mode and start the loopback test.

See [3] TS 34.108 and [4] TS 34.109 for details regarding generic call setup procedure and loopback test.

6.5.4.2 Procedure

- 1) Set the parameters of the CW generator or the interference signal generator as shown in Table 6.5.3 and Table 6.5.4. For Table 6.5.4, the frequency step size is 1 MHz.
- 2) Measure the BER of DCH received from the UE at the SS.
- 3) For Table 6.5.4, record the frequencies for which BER exceed the test requirements.

6.5.5 Test requirements

For Table 6.5.3, the measured BER, derived in step 2), shall not exceed 0.001. For Table 6.5.4, the measured BER, derived in step 2) shall not exceed 0.001 except for the spurious response frequencies, recorded in step 3). The number of spurious response frequencies, recorded in step 3) shall not exceed 24.

Table 6.5.3: Test parameters for In-band blocking characteristics

Parameter	10 MHz offset	15 MHz offset	Unit
DPCH_Ec	-114	-114	dBm / 3.84 MHz
I _{or}	-103.7	-103.7	dBm / 3.84 MHz
I _{blocking} (modulated)	-56	-44	dBm / 3.84 MHz
F _{uw} (offset)	+10 or -10	+15 or -15	MHz

Table 6.5.4: Test parameters for Out of band blocking characteristics

Parameter	Band 1	Band 2	Band 3	Unit
DPCH_Ec	-114	-114	-114	dBm / 3.84MHz
I _{or}	-103.7	-103.7	-103.7	dBm / 3.84MHz
I _{blocking} (CW)	-44	-30	-15	dBm
F _{uw} For operation in frequency bands as defined in subclause 4.2(a)	2050 < f < 2095 2185 < f < 2230	2025 < f < 2050 2230 < f < 2255	1 < f < 2025 2255 < f < 12750	MHz
F _{uw} For operation in frequency bands as defined in subclause 4.2(b)	1870 < f < 1915 2005 < f < 2050	1845 < f < 1870 2050 < f < 2075	1 < f < 1845 2075 < f < 12750	MHz
<u>For operation in bands referenced in 4.2(a), 2095<f<2110 MHz and 2170<f<2185 MHz, the appropriate in-band blocking or adjacent channel selectivity in subclause 6.4 and table 6.5.3 shall be applied.</u>				
<u>For operation in bands referenced in 4.2(b), 1915<f<1930 MHz and 1990<f<2005 MHz, the appropriate in-band blocking or adjacent channel selectivity in subclause 6.4 and table 6.5.3 shall be applied</u>				

NOTE:

- ~~1. For operation in bands referenced in 4.2(a), from 2095 < f < 2110 MHz and 2170 < f < 2185 MHz, the appropriate in-band blocking or adjacent channel selectivity in subclause 6.4.2 shall be applied.~~
- ~~2. For operation in bands referenced in 4.2(b), 1915 < f < 1930 MHz and 1990 < f < 2005 MHz, the appropriate in-band blocking or adjacent channel selectivity in subclause 6.4.2 shall be applied.~~
3. If the above Test Requirement differs from the Minimum Requirement then the Test Tolerance applied for this test is non-zero. The Test Tolerance for this test is defined in Annex F.2 and the explanation of how the Minimum Requirement has been relaxed by the Test Tolerance is given in Annex F.4.

6.8 Spurious Emissions

6.8.1 Definition and applicability

The spurious emissions power is the power of emissions generated or amplified in a receiver that appear at the UE antenna connector.

The requirements and this test apply to all types of UTRA for the FDD UE.

6.8.2 Minimum Requirements

The power of any narrow band CW spurious emission shall not exceed the maximum level specified in Table 6.8.1 and Table 6.8.2.

Table 6.8.1: General receiver spurious emission requirements

Frequency Band	Measurement Bandwidth	Maximum level	Note
9kHz ≤ f < 1GHz	100 kHz	-57 dBm	
1GHz ≤ f ≤ 12.75 GHz	1 MHz	-47 dBm	

Table 6.8.2: Additional receiver spurious emission requirements

	Frequency Band	Measurement Bandwidth	Maximum level	Note
For operation in frequency bands as defined in subclause 4.2(a)	1920 MHz ≤ f ≤ 1980 MHz	3.84 MHz	-60 dBm	Mobile transmit band in URA_PCH, Cell_PCH and idle state
	2110 MHz ≤ f ≤ 2170 MHz	3.84 MHz	-60 dBm	Mobile receive band

The reference for this requirement is [1] TS 25.101 subclause 7.9.1.

6.8.3 Test purpose

To verify that the UE spurious emission meets the specifications described in subclause 6.8.2. Excess spurious emissions increase the interference to other systems.

6.8.4 Method of test

6.8.4.1 Initial conditions

- 1) Connect a spectrum analyzer (or other suitable test equipment) to the UE antenna connector as shown in Figure A.8.
- 2) RF parameters are setup according to Table [TBD].
- 3) UE shall be camped on a cell
- 4) UE shall perform Location Registration (LR) before the test procedure in subclause 6.8.4.2, but not during it.
- 5) Neighbour cell list shall be empty.
- 6) Paging repetition period and DRX cycle shall be set to minimum (shortest possible time interval).

6.8.4.2 Procedure

- 1) Sweep the spectrum analyzer (or equivalent equipment) over a frequency range and measure the average power of spurious emission.

6.8.5 Test requirements

The all measured spurious emissions, derived in step 1), shall not exceed the maximum level specified in Table 6.8.3 and Table 6.8.4.

Table 6.8.3: General receiver spurious emission requirements

Frequency Band	Measurement Bandwidth	Maximum level	Note
9kHz ≤ f < 1GHz	100 kHz	-57 dBm	
1GHz ≤ f ≤ 12.75 GHz	1 MHz	-47 dBm	

Table 6.8.4: Additional receiver spurious emission requirements

	Frequency Band	Measurement Bandwidth	Maximum level	Note
For operation in frequency bands as defined in subclause 4.2(a)	1920 MHz ≤ f ≤ 1980 MHz	3.84 MHz	-60 dBm	Mobile transmit band in URA_PCH, Cell_PCH and idle state
	2110 MHz ≤ f ≤ 2170 MHz	3.84 MHz	-60 dBm	Mobile receive band

NOTE: If the above Test Requirement differs from the Minimum Requirement then the Test Tolerance applied for this test is non-zero. The Test Tolerance for this test is defined in Annex F.2 and the explanation of how the Minimum Requirement has been relaxed by the Test Tolerance is given in Annex F.4.

