

---

## Presentation of Specification to TSG or WG

---

<b>Source:</b>	<b>T3</b>
<b>Presentation to:</b>	<b>TSG T WG Meeting #12</b>
<b>Document for presentation:</b>	<b>TR 31.900 v2.0.0 "SIM/USIM Internal and External Interworking Aspects"</b>
<b>Presented for:</b>	<b>Approval</b>

---

### **Abstract of document:**

This Technical report describes

- the different cases of interworking between a 2G or 3G ICC and a 2G or 3G ME.
  - the different cases of interworking between any given ME/ICC combination and the rest of the network
  - the possibilities of interworking between a SIM and a USIM together on a single UICC
  - the possibilities of interworking between several USIMs on a single UICC
- 

### **Changes since last presentation to TSG T Meeting #11:**

Following a joint ad hoc session with SA3, a new section 4.4 was inserted and section 6.1, case 5 was modified.

---

### **Outstanding Issues:**

No outstanding issues have been identified.

---

### **Contentious Issues:**

No issues have been identified. It should however be noted that during the review of the scenario describing 2G security over UTRAN, it was identified that there appeared to be some commercial requirements for a scenario that would be forbidden by S3 specifications. There may be further discussion about this scenario in TSG-SA, but this is unlikely to have any impact on this TR.

# 3GPP TR 31.900 V2.0.0 (2001-06)

---

*Technical Specification*

## **3rd Generation Partnership Project; Technical Specification Group Terminals; SIM/USIM Internal and External Interworking Aspects (Release 1999)**



The present document has been developed within the 3<sup>rd</sup> Generation Partnership Project (3GPP™) and may be further elaborated for the purposes of 3GPP.

The present document has not been subject to any approval process by the 3GPP Organizational Partners and shall not be implemented. This Specification is provided for future development work within 3GPP only. The Organizational Partners accept no liability for any use of this Specification. Specifications and reports for implementation of the 3GPP™ system should be obtained via the 3GPP Organizational Partners' Publications Offices.

---

Keywords

---

SIM, USIM, UICC

**3GPP**

Postal address

---

3GPP support office address

---

650 Route des Lucioles - Sophia Antipolis  
Valbonne - FRANCE  
Tel.: +33 4 92 94 42 00 Fax: +33 4 93 65 47 16

Internet

---

<http://www.3gpp.org>

---

**Copyright Notification**

---

No part may be reproduced except as authorized by written permission.  
The copyright and the foregoing restriction extend to reproduction in all media.

© 2001, 3GPP Organizational Partners (ARIB, CWTS, ETSI, T1, TTA, TTC).  
All rights reserved.

---

# Contents

Foreword.....	4
Introduction.....	4
1 Scope .....	5
2 References .....	5
3 Abbreviations.....	6
4 Primary clarifications and definitions.....	7
4.1 2G and 3G.....	7
4.2 SIM, USIM and UICC .....	7
4.3 Types of ME .....	7
4.4 Types of VLR/SGSN and HLR/AuC.....	8
4.5 Security related terms .....	8
5 Interworking between the ME and the ICC.....	8
5.1 3G ME and UICC .....	9
5.2 2G ME and UICC .....	9
5.3 3G ME and SIM.....	9
5.4 2G ME and SIM.....	10
6 Authentication and key agreement in mixed networks.....	10
6.1 With 3G ME and UICC .....	10
6.2 With 2G ME and UICC .....	12
6.3 With 3G ME and SIM.....	14
6.4 With 2G ME and SIM.....	15
7 Interworking between a SIM application and a USIM application on a UICC.....	16
7.1 IMSI, secret key and authentication algorithm .....	17
7.2 File mapping .....	17
7.3 Access conditions .....	18
7.4 Secret codes .....	18
7.5 Activation of 2G and 3G operation modes .....	18
7.6 Selection of cyclic files.....	19
8 Interworking between USIM applications on a UICC .....	19
<b>Annex A: Interworking table .....</b>	<b>21</b>
<b>Annex B: Features for security interworking.....</b>	<b>25</b>
B.1 Conversion functions.....	25
B.2 3G algorithm execution modes.....	25
<b>Annex C: SIM/USIM file mapping table.....</b>	<b>27</b>
<b>Annex D: Change history.....</b>	<b>28</b>

---

## Foreword

This Technical Report has been produced by the 3<sup>rd</sup> Generation Partnership Project (3GPP).

The contents of the present document are subject to continuing work within the TSG and may change following formal TSG approval. Should the TSG modify the contents of the present document, it will be re-released by the TSG with an identifying change of release date and an increase in version number as follows:

Version x.y.z

where:

- x the first digit:
  - 1 presented to TSG for information;
  - 2 presented to TSG for approval;
  - 3 or greater indicates TSG approved document under change control.
- y the second digit is incremented for all changes of substance, i.e. technical enhancements, corrections, updates, etc.
- z the third digit is incremented when editorial only changes have been incorporated in the document.

---

## Introduction

This document describes the different cases of interaction between an Identity Module (GSM-SIM or a 3G-UICC) and a GSM or 3G mobile equipment with a special focus on the diverse situations that can apply in a mixed 2G/3G network environment.

Depending on the technical properties of other involved network elements, particularly during authentication and key agreement, the ICC and the ME may or must support some specific features to allow for compatibility. This is a complex matter and has generated some amount of confusion as the basic conditions implied by the 3G UICC are not always as clearly understood as they should be. The present document shall give a guideline by summarising the important details and applying them to the (theoretically) possible cases of security interworking along the transmission chain.

The document further tries to explain the options of interworking that exist internally when a SIM and one or more USIM(s) are implemented together on a single UICC.

As this document is a technical report and not a technical specification, none of its contents have the character of a requirement. Merely they should be seen as a clarifying summary and straightforward interpretation of the underlying core specifications.

---

# 1 Scope

The present document describes

- the different cases of interworking between a 2G or 3G ICC and a 2G or 3G ME.
- the different cases of interworking between any given ME/ICC combination and the rest of the network
- the possibilities of interworking between a SIM and a USIM together on a single UICC
- the possibilities of interworking between several USIMs on a single UICC

---

# 2 References

The following documents contain provisions which, through reference in this text, constitute provisions of the present document.

- References are either specific (identified by date of publication, edition number, version number, etc.) or non-specific.
- For a specific reference, subsequent revisions do not apply.
- For a non-specific reference, the latest version applies.

- [1] 3GPP TS 31.101: "UICC-Terminal Interface; Physical and Logical Characteristics"
- [2] 3GPP TS 31.102: "Characteristics of the USIM Application"
- [3] 3GPP TS 21.111: "USIM and IC Card Requirements"
- [4] 3GPP TS 22.100: "UMTS Phase 1"
- [5] 3GPP TS 22.101: "Service Aspects; Service Principles"
- [6] 3GPP TS 33.102: "3G Security; Security Architecture"
- [7] GSM TS 11.11: "Specification of the Subscriber Identity Module - Mobile Equipment Interface"

---

## 3 Abbreviations

For the purposes of the present document, the following abbreviations apply:

2G	2 <sup>nd</sup> Generation
3G	3 <sup>rd</sup> Generation
AKA	Authentication and Key Agreement
AuC	Authentication Centre
AUTN	Authentication Token
BSS	Base Station Subsystem
CHV	Card Holder Verification
CK	Ciphering Key in 3G
DF	Dedicated File
EF	Elementary File
GSM	Global System for Mobile Communication
HLR	Home Location Register
ICC	Integrated Circuit Card
IK	Integrity Key
IMSI	International Mobile Subscriber Identity
K	Secret Key in 3G
Kc	Ciphering Key in 2G
Ki	Secret Key in 2G
MAC	Message Authentication Code
ME	Mobile Equipment
PIN	Personal Identification Number
RAND	Random Challenge
RES	Authentication value returned by the USIM in 3G AKA or delivered by the 2G HLR/AuC
SGSN	Serving GPRS Support Node
SIM	Subscriber Identity Module
SRES	Authentication value returned by the SIM or by the USIM in 2G AKA
SQN	Sequence Number
TS	Technical Specification
TR	Technical Report
UICC	Universal Integrated Circuit Card
UMTS	Universal Mobile Telecommunication System
USIM	Universal Subscriber Identity Module
VLR	Visitor Location Register
XMAC	Expected Message Authentication Code calculated in the USIM in 3G AKA
XRES	Expected Authentication value delivered by the 3G HLR/AuC

---

## 4 Primary clarifications and definitions

For the purpose of this report, the following clauses shall clarify the meaning of some important terms.

### 4.1 2G and 3G

The abbreviation 2G stands for 2<sup>nd</sup> generation technology and characterises elements of a mobile communication system which are based on the GSM standard, i.e. 2G technical specifications or their equivalent successors under the 3GPP administration. A 2G entity only comprises the mandatory and optional functionality specified in GSM and does not ensure any forward compatibility with 3G.

The abbreviation 3G stands for 3<sup>rd</sup> generation technology and characterises elements of a mobile communication system which are based on 3GPP technical specifications. A 3G entity only comprises the mandatory and optional functionality specified in 3G, features for 2G backward compatibility are only included if explicitly required by the relevant 3G specifications.

Some 3G specifications differentiate the functional extent of a mobile network entity between releases 98 and earlier (R98-) and releases 99 and later (R99+). As for example a GSM ME exists in both release categories while a 3G ME is only defined from release 99 onwards, this split does not make sense without mentioning the respective technology. For the purpose of this document it therefore appears more appropriate to differentiate between 2G and 3G only, with the relationship given by

2G = GSM = GSM R98- or GSM R99+

3G = 3G R99+

NOTE: GSM or 3G releases later than R99 are not covered within this document. 3GPP TSG T WG 3 will produce a follow-up version for R4.

### 4.2 SIM, USIM and UICC

The most general term for a smart card, i.e. a micro-controller based access module, not only for mobile communication purposes, is "ICC". It is always a physical and logical entity and, in the context of this document, either a SIM or a UICC.

The SIM is the ICC defined for 2G. It has originally been specified as one physical and logical entity, not distinguishing platform and application. In 3G, the SIM may also be an application on the 3G UICC, then of course only represented by its logical characteristics. If the SIM application is active, the UICC is functionally identical to a 2G SIM. The SIM (or SIM application on a UICC) does only accept 2G commands. It is specified in GSM TS 11.11 [7].

Unlike the SIM, the USIM is not a physical entity, but a purely logical application that resides on a UICC. It does only accept 3G commands and is therefore not compatible with a 2G ME. The USIM may provide mechanisms to support 2G authentication and key agreement to allow a 3G ME to access a 2G network. It is specified in 3G TS 31.102 [2].

The UICC is the physical and logical platform for the USIM. It does at least contain one USIM application and may additionally contain a SIM application. Further to that, the UICC may contain additional USIMs and other applications, e.g. for mobile banking or mobile commerce purposes, if these fit with the basic physical and logical characteristics of the UICC. It is specified in 3G TS 31.101 [1].

### 4.3 Types of ME

For the purpose of this document, the following definitions shall apply for the ME:

- A 3G ME is either a 3G single mode ME that only supports a 3G radio access network or a 2G/3G dual mode ME that supports both, a 2G radio access network (GSM) and a 3G radio access network, whichever is present. In either case it can handle 3G AKA and 2G AKA and is able to interwork with either a USIM application on a UICC or a SIM. For better understanding, explicit usage of the term "2G/3G dual mode ME" shall point out particular requirements.



- A 2G ME does only support a 2G radio access network (GSM). It can only handle 2G AKA and is able to interwork with either a SIM application on a UICC or a SIM.

## 4.4 Types of VLR/SGSN and HLR/AuC

For the purpose of this document, the following definitions shall apply for the VLR/SGSN and HLR/AuC:

- A 2G HLR/AuC supports triplet generation for 2G subscriptions, but does not support quintet generation. Only 2G AKA can be performed. A triplet consists of RAND, RES and Kc, while a quintet comprises RAND, XRES, CK, IK and AUTN. A 2G HLR/AuC does not support any conversion functions.
- A 3G HLR/AuC supports quintet generation for 3G subscriptions. To support 2G AKA, i.e. to convert quintets into triplets, it shall support conversion functions c2 and c3 as defined in 3G TS 33.102 [6]. It may additionally support pure triplet generation for 2G subscriptions.
- A 2G VLR/SGSN only supports 2G AKA and can only be attached to a 2G BSS. It does not support any conversion functions.
- A 3G VLR/SGSN supports 3G AKA and 2G AKA. It can be attached to a 3G BSS and/or a 2G BSS. To convert quintets from a 3G HLR/AuC into triplets necessary for 2G AKA, it shall support conversion functions c2 and c3 as defined in 3G TS 33.102 [6].

## 4.5 Security related terms

2G AKA is the procedure to provide authentication of an ICC to a serving network domain and to generate the key Kc in accordance to the mechanisms specified in GSM 03.20. In a mixed 2G/3G network environment 2G AKA is performed when - except for the BSS - at least one other element is 2G.

3G AKA is the procedure to provide mutual authentication between an ICC and a serving network domain and to generate the keys CK and IK in accordance to the mechanisms specified in 3G TS 33.102 [6]. For 3G AKA all involved elements - except for the BSS - have to be 3G.

2G Security Context is a state that is established between a user and a serving network domain (i.e. between the ICC and the VLR/SGSN) after the execution of 2G AKA, with ciphering Kc available at either side.

3G Security Context is a state that is established between a user and a serving network domain (i.e. between the ICC and the VLR/SGSN) after the execution of 3G AKA, with ciphering and integrity protection keys CK and IK available at either side. 3G Security Context is still given, if these keys are converted into Kc to work with a 2G BSS.

---

# 5 Interworking between the ME and the ICC

The 3G system is designed to be compatible with GSM and several interworking requirements apply. Regarding the ICC/ME interface, two basic requirements can be identified in the 3G standards:

- In 3G TS 22.100 [4], section 10: "The UMTS mobile terminal shall support phase 2 and phase 2+ GSM SIMs as access modules to UMTS networks." In other words: A 3G ME shall support a 2G ICC.
- In 3G TS 22.101 [5], section 11.1.3: "It shall be possible to use the UICC in 2G terminals to provide access to GSM networks. In order to achieve that option, it shall be possible to store a module containing 2G access functionalities on the UICC which shall be accessed via the standard GSM SIM-terminal interface." In other words: The UICC may contain a SIM application.

Note that it is not a requirement that a USIM has to be supported by a 2G ME, with the reason that the USIM comprises new and enhanced security features which obviously cannot be supported by a 2G ME. Instead, in order to allow a 3G UICC to work in a 2G ME, it is feasible to put a GSM application (according to GSM TS 11.11 [7]) onto the UICC in addition to the USIM.

For the ICC/ME interface, with two main types of ME and two main types of ICC, four different scenarios can be identified. They are described in the following sections.

## 5.1 3G ME and UICC

A 3G ME has to support the UICC. 3G TS 31.101 [1] and 3G TS 31.102 [2] apply.

According to 3G TS 21.111 [3] a 3G ME does not support a 5V ME/UICC interface. This is valid even when it accesses the SIM application on the UICC. According to the same specification, a UICC does always support at least two voltage classes, i.e. a 5V only UICC cannot exist.

In case of a UICC inserted in a 3G ME, nothing but the 3G command set (as defined in 3G TS 31.101 [1] and 3G TS 31.102 [2]) can be used by the ME. In particular, the 2G command RUN GSM ALGORITHM is not available.

To support a 2G/3G dual mode ME in a 2G radio access network, the USIM may provide functions for 2G backward compatibility. Two particular USIM services are defined for such purposes:

1. **Service n° 27: "GSM Access"**. This service is essential when a 2G BSS is involved. The USIM additionally generates the 2G ciphering key Kc required by the 2G air interface. From the security point of view, this behaviour can be characterised as "**3G + Kc mode**" (see below). Further, the USIM supports some additional 2G data storage elements that are necessary for 2G radio access.
2. **Service n° 38: "GSM Security Context"**. This service is required when a 2G VLR/SGSN and/or a 2G HLR/AuC is involved. The USIM performs 2G AKA, i.e. it accepts 2G input data and generates 2G output data. From the security point of view, this behaviour can be characterised as "**virtual 2G mode**" (see below).

A 2G VLR/SGSN never goes with a 3G BSS. Hence when a 2G VLR/SGSN is involved, then a 2G BSS is always part of the transmission chain and service n° 27 is additionally required, i.e. services n° 27 and n° 38 have to be available at the same time.

If services n° 27 and n° 38 are not supported by the USIM (which the ME can detect from the USIM Service Table during the USIM activation procedure) network access is impossible in a mixed 2G/3G environment, even if a SIM application is available on the UICC. A 3G ME only accesses the USIM application on the UICC.

From the security point of view, the compatibility services are connected to up to three different operation modes (see also Annex B):

- **Normal 3G mode:** The results of the 3G algorithm are sent to the ME without any change. The USIM receives RAND and AUTN and responds with RES, CK and IK. This mode applies if service n° 27 is not available.
- **3G + Kc mode:** The 2G ciphering key Kc (derived from CK, IK) is additionally included in the response. The USIM receives RAND and AUTN and responds with RES, CK, IK and Kc. This requires conversion function c3 to be supported by the USIM. If service n° 27 is available in the USIM, this mode is always active and the ME picks the relevant values from the USIM response according to the present network situation.
- **Virtual 2G mode:** The USIM receives a 2G authentication request with RAND and returns a 2G authentication response with SRES (derived from RES) and ciphering key Kc (derived from CK, IK). This requires a particular algorithm execution mode plus conversion functions c2 and c3 to be supported by the USIM. If service n° 38 is available in the USIM, this mode is not always active. The ME may switch the USIM from normal 3G mode or 3G + Kc mode to virtual 2G mode by sending a particular command parameter according to the present network situation.

The services n° 27 and n° 38 are both optional. Network operators can decide whether to include them into their USIMs and hence to allow network access with lower security level.

## 5.2 2G ME and UICC

As a 2G ME is not required to support a USIM, however this is not excluded by the standard. If it does not support a USIM this combination will only work if a SIM application is provided by the UICC. GSM 11.11 [7] applies.

## 5.3 3G ME and SIM

A 3G ME supports a 2G SIM. For this purpose it has to provide 2G SIM interface in addition to the 3G UICC interface. Access is possible to both 3G and 2G networks. The services that can be provided in this case may be limited to GSM

like services. It is up to the 3G network operator to accept or reject the use of GSM SIMs as access modules to his network. GSM 11.11 [7] applies.

According to 3G TS 21.111 [3] and TS 22.100 [4] a 3G ME does not support a 5V ME/UICC or a 5V ME/SIM interface. This means that a 3G ME is not compatible with 5V only SIMs.

## 5.4 2G ME and SIM

This is the well-known 2G case. GSM 11.11 [7] applies. Access to 3G networks is not possible with this combination.

# 6 Authentication and key agreement in mixed networks

The authentication and key agreement procedure basically involves five network components (ICC, ME, BSS, VLR/SGSN and HLR), each of which can be either 2G or 3G. Not all combinations work due to missing compatibility, and some require specific support by the ICC. The following sections give an overview on the theoretically possible combinations when a given ICC/ME pair is used. A summary list is included in Annex A.

## 6.1 With 3G ME and UICC

When both ICC and ME are 3G (i.e. the ICC is a UICC), eight different combinations (security scenarios) of the other three network components remain. They are given in the following table:

Case	ICC	ME	BSS	VLR/SGSN	HLR/AuC	Service	Figure 1
1	3G	3G	3G	3G	3G	yes	A
2			2G	3G	3G	yes 1) 3)	B
3			3G	2G	3G	no	
4			2G	2G	3G	yes 2) 3)	C
5			3G	3G	2G	no	F
6			2G	3G	2G	yes 2) 3)	E
7			3G	2G	2G	no	
8			2G	2G	2G	yes 2) 3)	D

Note: 1) requires service n° 27 supported by the USIM  
 2) requires services n° 27 and n° 38 supported by the USIM  
 3) only with 2G/3G dual mode ME

**Case 1:** All system elements are 3G and thus capable of handling the related security mechanisms. 3G AKA is executed and 3G security context established. The USIM receives parameters RAND and AUTN and responds with RES, CK and IK.

NOTE: If service n° 27 is active in the USIM (to support mixed 2G/3G scenarios), Kc is generated by conversion function c3 and additionally included in the response. However, Kc is not needed in this security scenario and can be discarded by the ME.

This scenario is marked with "A" in figure 1.

**Case 2:** All system elements are 3G, except for the radio interface, which is 2G. This applies when a 3G subscriber roams into a 2G radio access network, which is connected to a 3G VLR/SGSN (e.g. when in the start phase of a 3G network not yet all existing 2G BSS are replaced by 3G technology, while the VLR/SGSN is already 3G).

3G AKA is executed. The 2G BSS is transparent for 3G authentication parameters but not capable of handling ciphering and integrity protection keys CK and IK. Therefore the 3G VLR/SGSN and the 3G ICC have to compute Kc from CK, IK with conversion function c3 and send it to the BSS and to the ME. Despite a 2G radio access network is involved, 3G security context is established. No service with a 3G single mode ME.

The USIM receives parameters RAND and AUTN and calculates RES, CK and IK. If service n° 27 is available, Kc is generated by conversion function c3 and additionally included in the response. The keys CK and IK are not needed in this security scenario and can be discarded by the ME. If the USIM does not support service n° 27, network access is not possible.

This scenario is marked with "B" in figure 1.

**Case 3:** All system elements are 3G, except for the VLR/SGSN which is 2G. As a 2G VLR/SGSN and a 3G BSS are not compatible, this theoretical combination cannot exist. No service in this case.

**Case 4:** ME, ICC and HLR/AuC are 3G, BSS and VLR/SGSN are 2G. This applies when a 3G subscriber roams into a 2G network - a very common case as networks will introduce 3G technology at different times or not at all.

Upon request by a 2G VLR/SGSN the 3G HLR/AuC produces 2G triplets RAND, RES, Kc out of 3G quintets RAND, XRES, CK, IK, AUTN. It therefore applies conversion function c2 to generate RES from XRES and conversion function c3 to generate Kc from CK and IK. RAND is left unchanged and AUTN is discarded. The 2G triplet is then sent to the VLR/SGSN. Between the VLR/SGSN and the USIM 2G AKA is executed, i.e. using RAND in the request and SRES in the response. No service with a 3G single mode ME.

To handle 2G AKA, the USIM must be capable to accept a request with RAND and return a response with SRES and Kc. The support of the virtual 2G mode is indicated by service n° 38 in the USIM Service Table. Since a 2G BSS is involved, service n° 27 is also necessary. In case the USIM does not support services n° 27 and n° 38, network access is not possible.

This scenario is marked with "C" in figure 1.

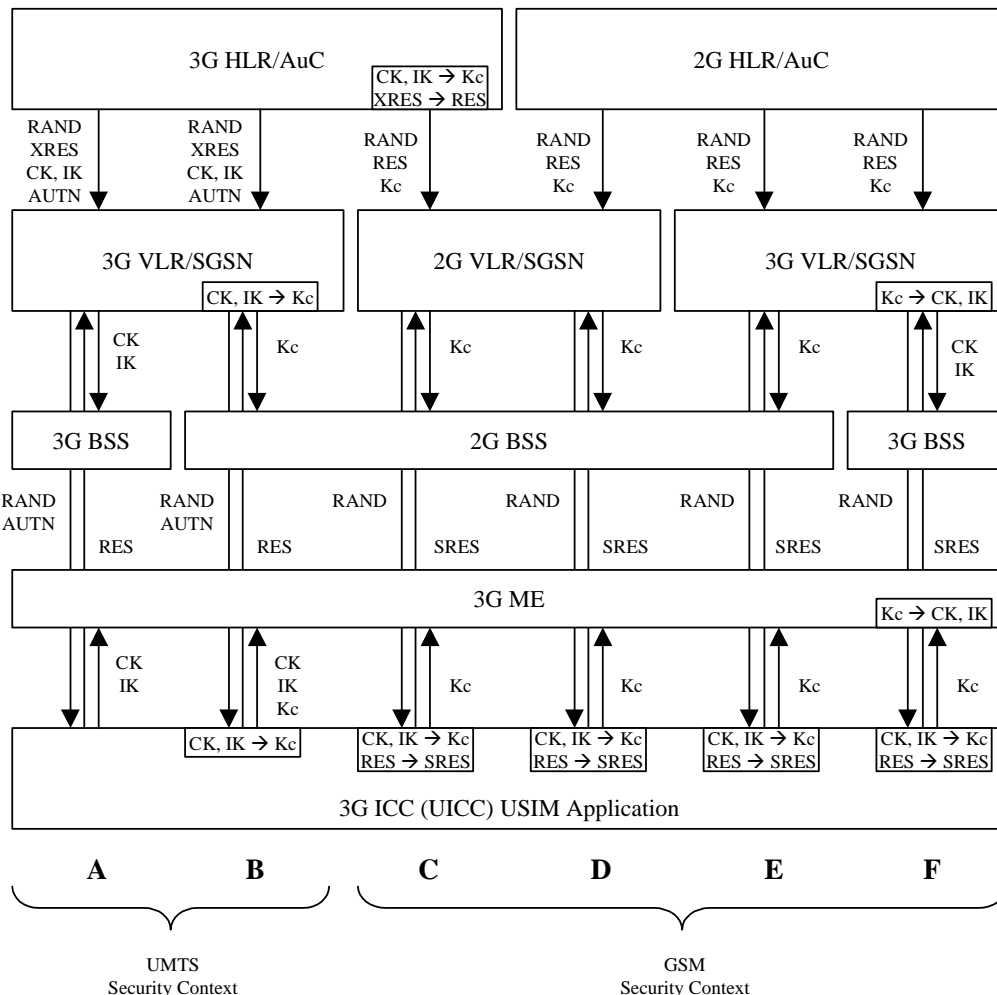

**Figure 1: Possible interworking scenarios of a 3G ME and UICC with different network environments**

**Case 5:** All system elements are 3G, except for the HLR/AuC, which is 2G. This scenario would result into 2G AKA, but although the necessary conversions would be technically feasible, this combination is not a valid option as it would violate a basic security requirement in 3G TS 33.102 [6]: A 3G ME with a UICC inserted with

a USIM activated and attached to a 3G BSS shall only participate in 3G AKA and shall not participate in 2G AKA. Accordingly the ME shall deny service in this case.

This scenario is marked with "F" in figure 1.

**NOTE:** There is one main consequence from this scenario: If a network operator issues UICCs in order to enable his customers to use a 3G access network (at home or while roaming), the related subscriptions should be installed in a 3G HLR/AuC. Otherwise authentication will fail as a 3G ME should not participate in 2G AKA.

**Case 6:** All system elements are 3G, except for the BSS and the HLR/AuC, which are 2G. It is possible to keep a 3G subscription in a 2G HLR/AuC, however on request by a 3G VLR/SGSN this can only deliver 2G triplets RAND, RES and Kc. The 3G VLR/SGSN is backward compatible and behaves like a 2G VLR/SGSN: Between the VLR/SGSN and the USIM 2G AKA is executed, i.e. using RAND in the request and SRES in the response. No service with a 3G single mode ME.

To handle 2G AKA, the USIM must be capable to accept a request with RAND and return a response with SRES and Kc. The support of the virtual 2G mode is indicated by service n° 38 in the USIM Service Table. Since a 2G BSS is involved, service n° 27 is also necessary. In case the USIM does not support services n° 27 and n° 38, network access is not possible.

This scenario is marked with "E" in figure 1.

**Case 7:** All involved system elements are 3G, except for the VLR/SGSN and the HLR/AuC, which are 2G. The situation is the same as in case 3 above: As a 2G VLR/SGSN a 3G BSS are not compatible, this theoretical combination cannot exist. No service in this case.

**Case 8:** ICC and ME are 3G and BSS, VLR/SGSN and HLR/AuC are 2G. The situation is actually very similar to case 4, but here the 2G HLR/AuC is delivering the necessary 2G triplets directly. No service with a 3G single mode ME.

Again this mixed network environment requires the virtual 2G mode in the USIM, indicated by service n° 38. As a 2G BSS is involved, service n° 27 is also necessary. If the USIM does not support services n° 27 and n° 38, network access is not possible.

This scenario is marked with "D" in figure 1.

## 6.2 With 2G ME and UICC

When the ME is 2G and the ICC is 3G (i.e. it is a UICC), this pair will only interoperate if a SIM application is provided by the UICC. The USIM application is not relevant. Again eight different combinations of the remaining three network components are existing. They are given in the following table:

Case	ICC	ME	BSS	VLR/SGSN	HLR/AuC	Service	Figure 2
1	3G with SIM Appl.	2G	3G	3G	3G	no	G
2			2G	3G	3G	yes 1)	
3			3G	2G	3G	no	H
4			2G	2G	3G	yes 1)	
5			3G	3G	2G	no	J
6			2G	3G	2G	yes 1)	
7			3G	2G	2G	no	I
8			2G	2G	2G	yes 1)	

Note: 1) No service if UICC does not contain a SIM application

**Cases 1, 3, 5, 7:** A 2G ME cannot interwork with a 3G BSS. Further, in cases 3 and 7, a 3G BSS does not work in combination with a 2G VLR/SGSN. No service in these cases.

**Case 2:** ME and BSS are 2G, the rest is 3G. This applies when a 3G subscriber with a 2G ME roams into a 2G radio access network, which is connected to a 3G VLR/SGSN (e.g. when in the start phase of a 3G network not yet all of the existing 2G BSS is replaced by 3G technology, while the VLR/SGSN is already 3G).

Upon request from a 3G VLR/SGSN, the 3G HLR/AuC delivers quintets. The VLR/SGSN, as it does not know

what type of ME it is communicating with, forwards RAND and AUTN. The 2G ME simply ignores AUTN, therefore the UICC only receives RAND and responds with SRES for 2G AKA. After determination that 2G AKA is to be executed, the 3G VLR/SGSN generates Kc from CK/IK (conversion function c3) and RES from XRES (conversion function c2). It then also performs 2G AKA. In the UICC only the SIM application is active.

This scenario is marked with "G" in figure 2.

**Case 4:** ME, BSS and VLR/SGSN are 2G, ICC and HLR/AuC are 3G. This applies when a 3G subscriber with a 2G ME roams into a 2G network.

Upon request from a 2G VLR/SGSN, the 3G HLR/AuC must produce 2G triplets out of 3G quintets. It therefore applies conversion function c2 to generate RES from XRES and conversion function c3 to generate Kc from CK, IK. RAND is left unchanged and AUTN is discarded. The 2G triplet is sent to the VLR/SGSN. The authentication and key agreement procedure is performed according to 2G specifications, i.e. using RAND in the request and SRES in the response. In the UICC only the SIM application is active.

This scenario is marked with "H" in figure 2.

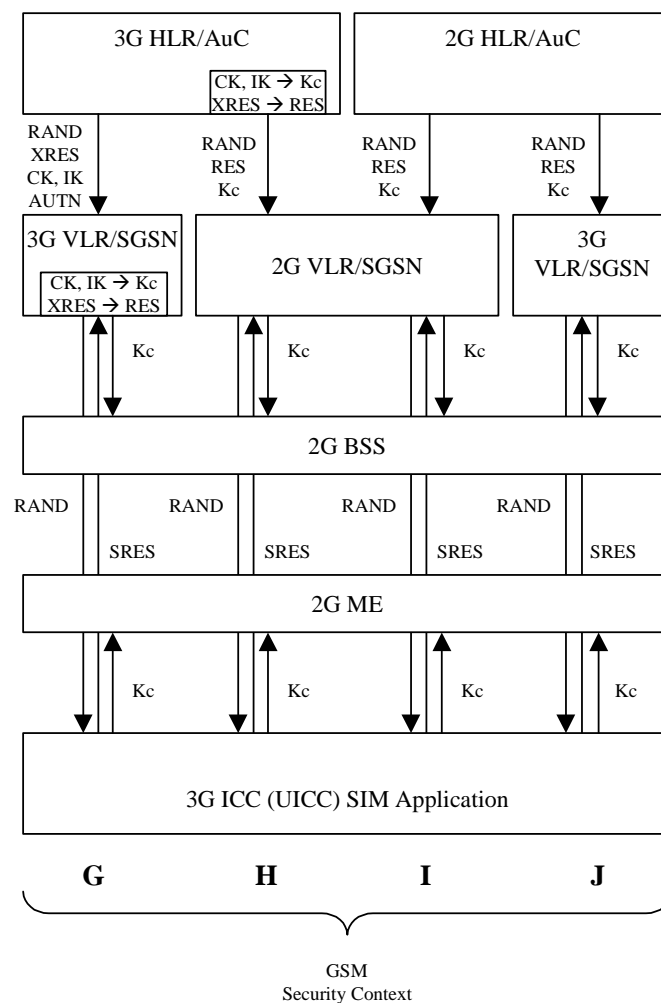

**Figure 2: Possible interworking scenarios of a 2G ME and UICC with different network environments**

**Case 6:** ME, BSS and HLR/AuC are 2G, ICC and VLR/SGSN are 3G. This applies when e.g. in the start-up phase of a 3G network a UICC (with SIM application) is introduced as the first migration step, while the rest of the network is still 2G and a user roams into another starting 3G network with 3G VLR/SGSN and 2G BSS technology.

Since the 3G VLR/SGSN is transparent for 2G AKA and the SIM application is active on the UICC, the system works entirely like 2G.

This scenario is marked with "J" in figure 2.

**Case 8:** ME, BSS, VLR/SGSN and HLR/AuC are 2G, only the ICC is a 3G UICC. This applies when in the start-up phase of a 3G network a UICC (with SIM application) is introduced as the first migration step, while the rest of the network is still 2G. With the UICC virtually being a SIM, this case can be seen as entirely 2G.

This scenario is marked with "I" in figure 2.

## 6.3 With 3G ME and SIM

Any 3G ME, not only if it is a 2G/3G dual mode ME, is required to work with a 2G SIM. Again eight different combinations of the remaining three network components are existing. These can be reduced to four, as the technology of the HLR/AuC is not relevant: A 2G HLR/AuC will always deliver 2G triplets and a 3G HLR/AuC will do the same because a 2G subscriber (his IMSI is linked to 2G functionality) is involved. The remaining four cases are given in the following table:

Case	ICC	ME	BSS	VLR/SGSN	HLR/AuC	Service	Figure 3
1	2G	3G	3G	3G	2G or 3G	yes	K
2			2G	3G		yes 1)	L
3			3G	2G		no	
4			2G	2G		yes 1)	M
Note: 1) 2G/3G dual mode ME required							

**Case 1:** ME, BSS and VLR/SGSN are 3G, the ICC is 2G (i.e. a SIM). This applies when e.g. a 2G subscriber with a 3G ME roams in a 3G network.

Any HLR/ AuC will deliver triplets to the 3G VLR/SGSN. The 3G BSS requires CK and IK, so the VLR/SGSN applies conversion function c3 to generate them from Kc. The SIM can only perform 2G AKA and returns SRES, Kc to the ME which also applies c3 to generate CK, IK. Despite the usage of CK and IK, security is based on Kc, i.e. 2G security context is established.

This scenario is marked with "K" in figure 3.

**Case 2:** ME and VLR/SGSN are 3G, ICC and BSS are 2G. This applies when e.g. a 2G subscriber with 3G ME roams in a 3G network with 2G BSS.

The situation is like in case 1, except that with a 2G BSS there is no need to derive CK, IK from Kc in the VLR/SGSN and in the ME. Both, the 3G VLR/SGSN and a 2G/3G dual mode ME can work with 2G AKA. No service with a 3G single mode ME.

This scenario is marked with "L" in figure 3.

**Case 3:** ME and BSS are 3G, ICC and VLR/SGSN are 2G. As a 2G VLR/SGSN and a 3G BSS are not compatible, this theoretical combination cannot exist. No service in this case.

**Case 4:** ICC, BSS and VLR/SGSN are 2G, the ME is 3G. This applies when e.g. a 2G subscriber with a 3G ME roams in a 2G network.

2G AKA is performed just like in a plain 2G situation. A 2G/3G dual mode ME is transparent for 2G AKA. No service with a 3G single mode ME.

This scenario is marked with "M" in figure 3.

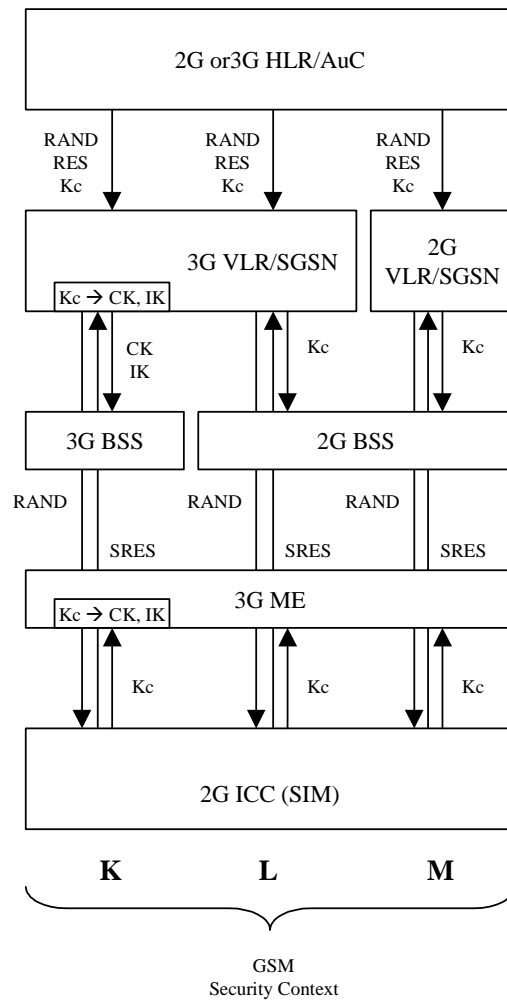

**Figure 3: Possible interworking scenarios of a 3G ME and SIM with different network environments**

### 6.4 With 2G ME and SIM

This ME/ICC combination results more or less in the "old" 2G case and is mentioned for completeness. Like in section 6.3 the HLR/AuC is not relevant, so theoretically 4 cases remain as given in the following table:

Case	ICC	ME	BSS	VLR/SGSN	HLR/AuC	Service	Figure 4
1	2G	2G	3G	3G	2G or 3G	no	N
2			2G	3G		yes	
3			3G	2G		no	
4			2G	2G		yes	

**Case 1:** A 2G ME cannot interwork with a 3G BSS. No service in this case.

**Case 2:** The VLR/SGSN is 3G, the HLR is 2G or 3G and the rest is 2G. The VLR/SGSN is backwards compatible and enters 2G mode. 2G AKA is executed.

This scenario is marked with "N" in figure 4.

**Case 3:** A 2G ME cannot interwork with a 3G BSS. Further, a 3G BSS does not work in combination with a 2G VLR/SGSN. No service in this case.

**Case 4:** The HLR is 2G or 3G and the rest is 2G. There is no difference to the well-known classic 2G case. 2G AKA is executed.



This scenario is marked with "O" in figure 4.

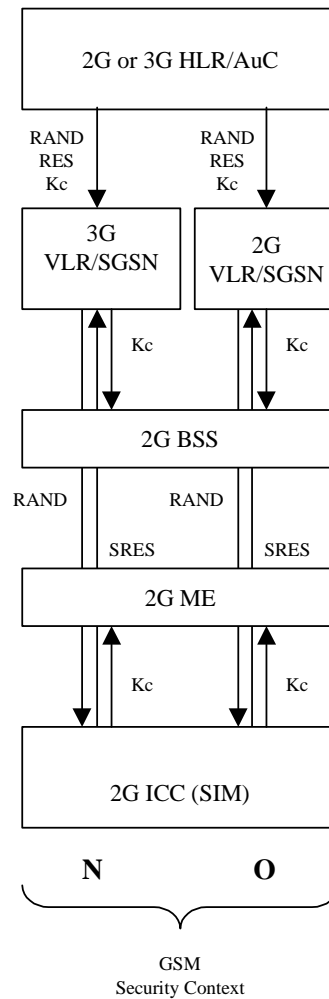

**Figure 4: Possible interworking scenarios of a 2G ME and SIM with different network environments**

## 7 Interworking between a SIM application and a USIM application on a UICC

A SIM application and a USIM application which are implemented together on a single UICC can never be active at the same time. Neither can they be switched from one to the other. Their activity solely depends on the type of ME in which they are inserted: A 2G ME will always activate the SIM application, while a 3G ME only uses the USIM application. Hence a direct way of interworking does not exist.

However, both applications may share certain elements, either to enable an intended basic subscription mode of the UICC (single or double subscription) or to optimise memory consumption, but still both applications have to be virtually independent from a functional point of view. This means that a 2G ME can interwork with the SIM application without any influence from the USIM, while a 3G ME finds all the mandatory characteristics of the USIM application. Naturally, independence ends if one application changes shared data which is later accessed by the other application because the UICC was inserted into another type of ME. This has to be taken into account.

The following sections shall describe the possible options.

## 7.1 IMSI, secret key and authentication algorithm

In the HLR/AuC, a single subscription is identified by a particular IMSI, which is connected to a particular secret key (given by "Ki" for 2G, "K" for 3G) and to one type of authentication algorithm ("A3/A8" for 2G, "f1-f5" for 3G). At no time, a single IMSI may be connected to more than one secret key or algorithm. This is valid for both 2G and 3G contexts. Further, it applies that

- Length and Format ( $\text{IMSI}_{2G}$ ) = Length and Format ( $\text{IMSI}_{3G}$ )
- Length (Ki) = Length (K)
- 2G-Type Algorithm = Part of 3G Algorithm + Conversion Functions c2, c3

For the third "equation" see Annex B2 or 3G TS 31.102 [2] and 3G TS 33.102 [6]. This 2G behaviour of the 3G algorithm is the same as the virtual 2G mode described in section 5.1. If it is always active, e.g. in a SIM application or in a 2G HLR/AuC, it shall in the following be called a fixed virtual 2G mode. Then, in fact, it is a 2G algorithm.

There are three possible options for the UICC:

1. **Separate IMSI & Separate Secret Key:** This case applies if the network operator - for some reason - wants to administrate the 2G and the 3G subscription, i.e. the usage of a 2G or 3G ME, fully independent. The two subscriptions can be maintained in either in a single 2G or 3G HLR/AuC or in different dedicated 2G and 3G HLR/AuCs. Then USIM and SIM applications also have to keep separate IMSIs, i.e.  $\text{IMSI}_{3G} \neq \text{IMSI}_{2G}$ . The secret keys have to be different as well, i.e.  $K \neq K_i$ . Of course, the algorithms in the UICC have to correspond to the algorithms associated with the IMSIs in the HLR/AuCs. The USIM application needs a 3G algorithm, while for the SIM application it can either be
  - a 2G algorithm on its own or
  - a 3G algorithm in fixed virtual 2G mode. In that case the UICC needs to implement a 3G algorithm only, which from the SIM application is executed in 2G mode. The HLR/AuC must support this option accordingly.
2. **Separate IMSI & Shared Secret Key:** From a functional point of view, this option is identical to option 1, except that the UICC saves 128 bits for the storage of a second secret key. On the other hand, the deliberate assignment of the same secret key to two different IMSIs would require particular solutions during secret key generation and pre-personalization.
3. **Shared IMSI & Shared Secret Key:** This case applies if the network operator wants to have one single subscription for a user, independent of the usage of a 2G or 3G ME. Consequently the UICC has to carry the same identification details, i.e. IMSI and secret key, in both SIM and USIM applications. On the network side there is a single entry consisting of one IMSI and one secret key in either a 2G or a 3G HLR/AuC, i.e.  $\text{IMSI}_{3G} = \text{IMSI}_{2G}$  and  $K = K_i$ . In a 2G HLR the algorithm has to be a 3G-type in fixed virtual 2G mode (a 3G algorithm does not fit into a 2G HLR and a 2G algorithm does not fit with the USIM application on the UICC) while in a 3G HLR the algorithm is a 3G-type. On the UICC side there is not much choice: The USIM application essentially needs a 3G algorithm while for the SIM application it can only be a 3G-algorithm in (fixed) 2G mode as there is no 2G-type in the network. Again this has the advantage of having only one shared 3G algorithm on the UICC, which from the SIM application is executed in 2G mode.

The fourth theoretical combination, namely shared IMSI & separate secret keys, is not a valid option as a single IMSI cannot be associated with more than one secret key simultaneously.

## 7.2 File mapping

When comparing the file structure of a SIM in GSM TS 11.11 [7] with that of a USIM in 3G TS 31.102 [2] it strikes that many not only have the same name and file identifier (although under different DFs) but are entirely equal by size and content parameters. This generally allows for memory efficient implementation of a SIM together with a USIM as these files can be shared by both applications, i.e. necessary storage capacity is only required once. Further, shared files speed up the pre-personalization process as they save valuable programming time.

Therefore files should be mapped as far as possible, i.e. in all cases where basic properties are equal and identical contents do not conflict with the access by either a 2G or a 3G ME or with intended subscription differences when

separate IMSIs are used (cases 1 or 2 in section 7.1). Mapping is not possible, when the content is clearly subscription dependent like in case of IMSI, Kc, KcGPRS or MSISDN in a double subscription UICC.

Annex C gives an overview on the SIM and USIM files that potentially can be mapped. A case by case decision should be conducted by the network operator / card manufacturer for each UICC implementation.

## 7.3 Access conditions

If a EF or DF is accessible in both 2G and 3G operation modes (e.g. in the MF: EF-PL in the UICC can be identical to EF-ELP in the SIM), then independent 2G and 3G access conditions may be defined for the file. The UICC does not check the consistency of the access conditions in both modes.

Therefore it is possible that the same EF or DF has different security attributes in 2G and 3G operation mode. It is the responsibility of the network operator and the card manufacturer to ensure at the personalisation stage that the security attributes for 2G and 3G session are the same, if necessary.

## 7.4 Secret codes

In 3G mode, 8 Application PINs with global key references are available and the UICC also supports up to 8 Local PINs with specific key references. Local PINs can only be used within an ADF. Further, up to 10 administrative PINs can be defined. A replacement PIN, called Universal PIN, may also exist.

In 2G mode, only CHV1 and CHV2 are available. They apply to files in DF-GSM and DF-TELECOM. Additionally, up to 11 administrative PINs can be defined.

Mapping of PINs between 2G and 3G operation modes, so that activation, deactivation or changing of a PIN in one operation mode has the same effect in the other operation mode, shall follow the following principles:

- **Mapping of CHV1**

CHV1 in the SIM application can be mapped to any USIM application PIN with a global key reference (or to the Universal PIN), but to only one at a time.

- **Mapping of CHV2**

CHV2 in the SIM application can be mapped to the corresponding local key reference belonging to the USIM application to which the CHV1 is mapped. In the 2G operation mode, this PIN is considered to be global, in the 3G operation mode, it is seen as a being local. If mapped, then, with respect to the requirement in TS GSM 11.11 [7] for CHV2, this PIN cannot be disabled in either operation mode. The UICC will return an appropriate error condition in that case.

- **Mapping of Local PINs**

A SIM does not support Local PINs, hence there is no correspondence in 2G operation mode. Local PINs cannot be mapped.

- **Mapping of administrative PINs**

The mapping of administrative PINs between the 2G and 3G operation modes is fully under the discretion of each network operator and card manufacturer.

## 7.5 Activation of 2G and 3G operation modes

After a cold reset has been performed (i.e. during UICC activation), the ATR sent by the UICC is compliant to 3G TS 31.101 [1]. No particular operation mode is active at this stage. The selection and activation of either 2G operation mode (i.e. the SIM application) or 3G operation mode, is implicitly done by the ME when sending the first command. The following table describes the different possible cases.

ICC / ME Combination	Class Byte of First Command	Resulting Operation Mode	Remark
UICC with or without a SIM application in a 3G or 2G/3G dual mode ME	'0X' or '8X'	3G	The USIM application shall reject commands with class byte = 'A0'.  First command right after ATR can be SELECT or STATUS.
UICC with a SIM application in a 2G ME	'A0'	2G	The SIM application may reject commands with class byte = '0X' or '8X'.  First command right after ATR can be SELECT, STATUS or GET RESPONSE.
UICC without a SIM application in a 2G ME	'A0'	No operation!	All further commands with class byte = 'A0' will be rejected.

A 3G or 2G/3G dual mode ME will only send commands with class byte = '0X' or '8X'. A 2G ME will only send commands with class byte = 'A0'. The operation mode selection takes place regardless of the result of the command (i.e. if it was successful or not).

## 7.6 Selection of cyclic files

As the SIM application and the USIM application are based on individual specifications, a particular difference applies for the selection of cyclic files.

For the SIM, GSM TS 11.11 [7] specifies that "After selection of a cyclic file (for either operation), the record pointer shall address the record updated or increased last.", whereas for the USIM it is required in 3G TS 31.101 [1] that "After a successful selection the record pointer is undefined.". In the latter case, the record pointer is set implicitly by the subsequent access command.

Therefore, in the case of a selection of cyclic files, the UICC will behave corresponding to its current operation mode, i.e. comply to 2G requirements when the SIM application is active and to 3G requirements when the USIM application is active.

A 3G ME shall handle this situation accordingly, i.e. depending on whether a SIM or a UICC is inserted.

---

## 8 Interworking between USIM applications on a UICC

If a UICC contains more than one USIM application, these are normally related to separate subscriptions, either from the same or from different network operators. In that case IMSIs and secret keys are different and cannot be shared. The authentication algorithm may be shared if the nature of the subscriptions does not require different algorithms.

Concerning the mapping of files between multiple USIMs, only the following guidelines can be given:

- If the UICC is intended to be used by a single user, all user relevant files (that can be updated by the user) could be mapped. The phonebook will preferably be located under DF TELECOM, to enable global access from all applications. In a multi-user model, user relevant files should not be mapped and a specific phonebook will be under each DF USIM.

- All directly subscription relevant files (like Kc or MSISDN) or those needed to differentiate the subscriptions should not be mapped.
- All other files: Mapping depends on conditions of use in a multi-subscription environment.

If a SIM application is existing in addition to multiple USIM applications, mapping can be done according to section 7 and Annex C with one of the USIM applications.

As it is not possible to cover all specific situations that might require multiple USIMs on a UICC, such design decisions should be taken on a case by case basis by considering each data field and its possible use.

---

## Annex A: Interworking table

The following table lists the complete set of interworking scenarios introduced by the two possible types of generation (2G or 3G) with each of the main network elements involved in authentication and key agreement. These are ICC, ME, BSS, VLR/SGSN and HLR/AuC.

In each case the function of the network elements is commented when the behaviour is particular for the case. No comment means that the behaviour is not special for the purpose of interworking. If a case was identified as not functional, i.e. interworking fails somewhere through the transmission chain, this is indicated by grey background. A more detailed explanation of each case can be found in section 6 of this document. The character in the last column refers to figures 1 to 4 in section 6.

ICC	ME	BSS	VLR	AUC	ICC	ME	BSS	VLR/SGSN	HLR/AuC	Security Con	Figure 1-4
2	2	2	2	2						2G	O
2	2	2	2	3					3G HLR/AC generates 2G triplets for 2G IMSI	2G	O
2	2	2	3	2				3G VLR/SGSN transparent for 2G AKA		2G	N
2	2	2	3	3					3G HLR/AC generates 2G triplets for 2G IMSI	2G	N
2	2	3	2	2			3G BSS incompatible with 2G ME and 2G VLR/SGSN				
2	2	3	2	3			3G BSS incompatible with 2G ME and 2G VLR/SGSN				
2	2	3	3	2			3G BSS incompatible with 2G ME				
2	2	3	3	3			3G BSS incompatible with 2G ME				
2	3	2	2	2		3G ME transparent for 2G AKA 2)				2G	M
2	3	2	2	3		3G ME transparent for 2G AKA 2)			3G HLR/AC generates 2G triplets for 2G IMSI	2G	M
2	3	2	3	2		3G ME transparent for 2G AKA 2)		3G VLR/SGSN transparent for 2G AKA		2G	L
2	3	2	3	3		3G ME transparent for 2G AKA 2)		3G VLR/SGSN transparent for 2G AKA	3G HLR/AC generates 2G triplets for 2G IMSI	2G	L
2	3	3	2	2			3G BSS incompatible with 2G VLR/SGSN				
2	3	3	2	3			3G BSS incompatible with 2G VLR/SGSN				
2	3	3	3	2		3G ME transparent for 2G AKA, generates CK,	3G BSS transparent for 2G AKA	3G VLR/SGSN transparent for 2G AKA, generates CK,		2G	K

2	3	3	3	3		3G ME transparent for 2G AKA, generates CK,	3G BSS transparent for 2G AKA	3G VLR/SGSN transparent for 2G AKA, generates CK,	3G HLR/AC generates 2G triplets for 2G IMSI	2G	K
3	2	2	2	2	USIM incompatible with 2G ME						
3	2	2	2	3	USIM incompatible with 2G ME						
3	2	2	3	2	USIM incompatible with 2G ME						
3	2	2	3	3	USIM incompatible with 2G ME						
3	2	3	2	2	USIM incompatible with 2G ME		3G BSS incompatible with 2G ME				
3	2	3	2	3	USIM incompatible with 2G ME		3G BSS incompatible with 2G ME				
3	2	3	3	2	USIM incompatible with 2G ME						
3	2	3	3	3	USIM incompatible with 2G ME						
3	3	2	2	2	2G mode 4)	3G ME transparent for 2G AKA 2)				2G	D
3	3	2	2	3	2G mode 4)	3G ME transparent for 2G AKA 2)			3G HLR/AC generates Kc from CK, IK and RES from XRES	2G	C
3	3	2	3	2	2G mode 4)	3G ME transparent for 2G AKA 2)		3G VLR/SGSN transparent for 2G AKA		2G	E
3	3	2	3	3	3G + Kc mode 3)	2)		3G VLR/SGSN generates Kc from CK, IK		3G	B
3	3	3	2	2			3G BSS incompatible with 2G VLR/SGSN				
3	3	3	2	3			3G BSS incompatible with 2G VLR/SGSN				
3	3	3	3	2		3G ME with UICC shall not execute 2G AKA when attached to a 3G BSS					F



3	3	3	3	3						3G	A
3 1)	2	2	2	2	SIM appl. active					2G	I
3 1)	2	2	2	3	SIM appl. active				3G HLR/AC generates Kc from CK, IK and RES from XRES	2G	H
3 1)	2	2	3	2	SIM appl. active			3G VLR/SGSN transparent for 2G AKA		2G	J
3 1)	2	2	3	3	SIM appl. active			3G VLR/SGSN generates Kc from CK, IK and RES from XRES		2G	G
3 1)	2	3	2	2			3G BSS incompatible with 2G ME and 2G VLR/SGSN				
3 1)	2	3	2	3			3G BSS incompatible with 2G ME and 2G VLR/SGSN				
3 1)	2	3	3	2			3G BSS incompatible with 2G ME				
3 1)	2	3	3	3			3G BSS incompatible with 2G ME				

Note: 1) UICC with SIM application  
 2) 2G/3G dual mode ME required, no service otherwise  
 3) Support of service n° 27 required in the USIM, no service otherwise  
 4) Support of services n° 27 and n° 38 required in the USIM, no service otherwise

---

## Annex B: Features for security interworking

The following sections shall summarise the features defined to convert security parameters between 2G and 3G or vice versa. For more information see 3G TS 33.102 [6].

---

### B.1 Conversion functions

**Conversion function c1** converts a 128 bit 3G random challenge into a 128 bit 2G random challenge. Both values have the same format, i.e. they are equal.

$$c1: \quad \text{RAND}_{2G} = \text{RAND}_{3G}$$

**Conversion function c2** converts a 3G expected authentication response XRES into a 2G expected authentication response RES (in the AuC or the VLR/SGSN) or a 3G authentication response RES into a 2G authentication response SRES (in the USIM).

$$c2: \quad \text{RES}_{2G} = \text{XRES}_{3G,1} [\text{xor } \text{XRES}_{3G,2} [\text{xor } \text{XRES}_{3G,3} [\text{xor } \text{XRES}_{3G,4}]]]$$

$$\text{SRES}_{2G} = \text{RES}_{3G,1} [\text{xor } \text{RES}_{3G,2} [\text{xor } \text{RES}_{3G,3} [\text{xor } \text{RES}_{3G,4}]]]$$

where  $\text{RES}_{3G,i}$  or  $\text{XRES}_{3G,i}$  are 32 bits long and  $(\text{X})\text{RES}_{3G} = (\text{X})\text{RES}_{3G,1} [ \parallel (\text{X})\text{RES}_{3G,2} [ \parallel (\text{X})\text{RES}_{3G,3} [ \parallel (\text{X})\text{RES}_{3G,4} ] ] ]$  depending on the length of  $(\text{X})\text{RES}_{3G}$  (a multiple of 32 bit or else be padded with "0"). In the USIM, conversion function c2 must be supported in connection with conversion function c3 and the ability to execute a "reduced" 3G algorithm. This optional service is indicated by service n° 38 in the USIM Service Table.

**Conversion function c3** converts the 128 bit 3G ciphering and integrity protection keys CK and IK into the 64 bit 2G ciphering key Kc. This function is applied in the AuC or VLR/SGSN and in the USIM.

$$c3: \quad \text{Kc} = \text{CK}_1 \text{ xor } \text{CK}_2 \text{ xor } \text{IK}_1 \text{ xor } \text{IK}_2$$

where  $\text{CK}_i$  and  $\text{IK}_i$  are both 64 bits long and  $\text{CK} = \text{CK}_1 \parallel \text{CK}_2$  and  $\text{IK} = \text{IK}_1 \parallel \text{IK}_2$ . In the USIM, the optional support of conversion function c3 is indicated by service n° 27 in the USIM Service Table.

**Conversion function c4** converts a 64 bit 2G Kc into a 128 bit 3G CK. This function is applied in the ME and in the VLR/SGSN.

$$c4: \quad \text{CK} = \text{Kc} \parallel \text{Kc}$$

**Conversion function c5** converts a 64 bit 2G Kc into a 128 bit 3G IK. This function is applied in the ME and in the VLR/SGSN.

$$c5: \quad \text{IK} = (\text{Kc}_1 \text{ xor } \text{Kc}_2) \parallel \text{Kc} \parallel (\text{Kc}_1 \text{ xor } \text{Kc}_2)$$

where  $\text{Kc}_i$  are both 32 bits long and  $\text{Kc} = \text{Kc}_1 \parallel \text{Kc}_2$ .

---

### B.2 3G algorithm execution modes

The 3G algorithm in the USIM consists of five sub-functions that have to be executed in order to verify the received data and generate the necessary responses. For more information see 3G TS 31.102 [2] and 3G TS 33.102 [6].

In **normal 3G mode** the input is given by RAND and AUTN. The USIM computes

- f5 to get the anonymity key AK. AK is then used to retrieve the sequence number SQN.
- f1 to derive XMAC. XMAC is then used to verify the authenticity of the home environment.
- f2 to calculate the 3G authentication response RES

- f3 to get the 3G ciphering key CK
- f4 to get the 3G integrity protection key IK

The USIM returns RES, CK and IK.

In **3G + Kc mode** the input is also given by RAND and AUTN. The USIM computes the same sequence of functions but in the end applies conversion function c3 to generate a 2G Kc from CK and IK. The USIM returns RES, CK, IK and Kc. Kc is always returned if this mode is active in the USIM. If not needed, the ME may discard the additional Kc.

In **virtual 2G mode** the input is only given by RAND. The USIM skips functions f5 and f1 and only executes f2, f3 and f4 ("reduced" 3G algorithm). Subsequently it applies conversion function c3 to generate 2G Kc from CK, IK and conversion function c2 to generate 2G SRES from RES. The USIM returns SRES and Kc. The ME can require the USIM to operate in this mode by sending a specific command parameter. If it is not supported by the USIM, an error indication is returned.

NOTE: The 3G algorithm in 2G mode is virtually (i.e. by input and output) identical to a 2G algorithm. A UICC with USIM and SIM applications may make use of that and implement a 3G algorithm only, which from the SIM application is executed in 2G mode.

## Annex C: SIM/USIM file mapping table

The following table lists all SIM and USIM files that can be mapped in a UICC. Files not mentioned do not have a corresponding file in both applications. Mapping with multiple USIMs is not considered.

SIM Application DF / EF	USIM Application DF / EF	Mapping possible	
		single subscription UICC	double subscription UICC
GSM / IMSI	USIM / IMSI	yes	no
GSM / HPLMN	USIM / HPLMN	yes	yes, 1)
GSM / ACM	USIM / ACM	yes	yes, 1)
GSM / ACMmax	USIM / ACMmax	yes	yes, 1)
GSM / PUCT	USIM / PUCT	yes	yes, 1)
GSM / GID1	USIM / GID1	yes	yes, 1)
GSM / GID2	USIM / GID2	yes	yes, 1)
GSM / SPN	USIM / SPN	yes	yes, 1)
GSM / CBMI	USIM / CBMI	yes	
GSM / CBMIR	USIM / CBMIR	yes	
GSM / CBMID	USIM / CBMID	yes	yes, 1)
GSM / ACC	USIM / ACC	yes	no
GSM / FPLMN	USIM / FPLMN	yes	yes, 1)
GSM / LOCI	USIM / LOCI	yes	
GSM / LOCIGPRS	USIM / PSLOCI	yes	
GSM / AD	USIM / AD	yes	
GSM / ECC	USIM / ECC	yes	
GSM / eMLPP	USIM / eMLPP	yes	yes, 1)
GSM / AAeM	USIM / AAeM	yes	yes, 1)
GSM / DCK	USIM / DCK	yes	yes, 1)
GSM / CNL	USIM / CNL	yes	yes, 1)
GSM / PLMNwACT	USIM / PLMNwACT	yes	
GSM / OPLMNwACT	USIM / OPLMNwACT	yes	yes, 1)
GSM / HPLMNwACT	USIM / HPLMNwACT	yes, 3)	
GSM / RPLMNACT	USIM / RPLMNACT	no	
GSM / SUME	TELECOM / SUME	yes	
GSM / Kc	USIM / GSM / Kc	yes	no
GSM / KcGPRS	USIM / GSM / KcGPRS	yes	no
GSM / BCCH	USIM / GSM / BCCH	yes	
GSM / CPBCCH	USIM / GSM / CPBCCH	yes	
GSM / INVSCAN	USIM / GSM / INVSCAN	yes	yes, 1)
TELECOM / SMS	USIM / SMS	yes	
TELECOM / SMSP	USIM / SMSP	yes	yes, 1)
TELECOM / SMSS	USIM / SMSS	yes	
TELECOM / SMSR	USIM / SMSR	yes	
TELECOM / SDN	USIM / SDN	yes	yes, 1)
TELECOM / FDN	USIM / FDN	yes	
TELECOM / BDN	USIM / BDN	yes	
TELECOM / CMI	USIM / CMI	yes	
TELECOM / MSISDN	USIM / MSISDN	yes	no
TELECOM / EXT2	USIM / EXT2	yes	
TELECOM / EXT3	USIM / EXT3	yes	yes, 1)
TELECOM / EXT4	USIM / EXT4	yes	
TELECOM / ADN	... / PHONEBOOK / ADN	yes, required, 2)	
TELECOM / EXT1	... / PHONEBOOK / EXT1	yes, required, 2)	
TELECOM / ECCP	... / PHONEBOOK / CCP1	yes, required, 2)	
GSM / MEXE / all files	USIM / MEXE / all files	yes	yes, 1)
GSM / SoLSA / all files	USIM / SoLSA / all files	yes	yes, 1)

Note: 1) No mapping, if subscription specific differences are required  
2) SIM file to be mapped with related USIM file either in DF PHONEBOOK under DF USIM or in DF PHONEBOOK under DF TELECOM  
3) Only if the same settings apply to 2G and 3G operation

## Annex D: Change history

Change history							
Date	TSG #	TSG Doc.	CR	Rev	Subject/Comment	Old	New
2000-11	-	-	-	-	1 <sup>st</sup> draft version created by rapporteur for discussion at T3 #16 as part of the work for the T3 work item "Report on SIM/USIM interworking"		0.0.1
2001-01	-	-	-	-	2 <sup>nd</sup> draft version created by rapporteur for discussion at T3 #17. Sections 7, 8 and Annex C added.	0.0.1	0.0.2
2001-01	-	-	-	-	3 <sup>rd</sup> draft version during T3 #17. Additions, Corrections and clarifications.	0.0.2	0.1.0
2001-01	-	-	-	-	4 <sup>th</sup> draft version after T3 #17. Further corrections and clarifications. Forwarded to S1, S3, T2 and N1 for comments.	0.1.0	0.2.0
2001-03	-	-	-	-	5 <sup>th</sup> draft version during T3 Adhoc #28. Section 6.1, case 5 modified according to input from S3.	0.2.0	0.3.0
2001-03	-	-	-	-	6 <sup>th</sup> draft version during T3 #18. Sections 7.3, 7.4, 7.5 and 7.6 added.	0.3.0	0.4.0
2001-03	-	-	-	-	7 <sup>th</sup> draft version after T3 #18. Minor modifications. Presented to TSG-T for information.	0.4.0	0.4.1
2001-03	TP-11	TP-010045	-	-	Presented for information to TSG-T #11	0.4.1	1.0.0
2001-05	-	-	-	-	Version after T3 AdHoc #37 (Joint with SA3), new section 4.4 inserted, section 6.1, case 5 modified	1.0.0	1.1.0
2001-05	-	-	-	-	Version during T3#19. Minor modifications.	1.1.0	1.1.1
2001-05	-	-	-	-	Version after T3#19 plenary presentation. Editorial modifications.	1.1.1	1.1.2
2001-06	TP-12	TP-010113			Presented to TSG-T #12 for approval	1.1.2	2.0.0