

## CHANGE REQUEST

⌘ **33.107** CR **CRNum** ⌘ rev **-** ⌘ Current version: **6.1.0** ⌘

For **HELP** on using this form, see bottom of this page or look at the pop-up text over the ⌘ symbols.

**Proposed change affects:** UICC apps  ME  Radio Access Network  Core Network

<b>Title:</b>	⌘ Enhancements for the Functional Architecture chapter		
<b>Source:</b>	⌘ SA3-LI		
<b>Work item code:</b>	⌘ SEC1-LI	<b>Date:</b>	⌘ 27-04-2004
<b>Category:</b>	⌘ <b>F</b>	<b>Release:</b>	⌘ Rel-6
	Use <u>one</u> of the following categories: <b>F</b> (correction) <b>A</b> (corresponds to a correction in an earlier release) <b>B</b> (addition of feature), <b>C</b> (functional modification of feature) <b>D</b> (editorial modification) Detailed explanations of the above categories can be found in 3GPP <a href="#">TR 21.900</a> .		Use <u>one</u> of the following releases: 2 (GSM Phase 2) R96 (Release 1996) R97 (Release 1997) R98 (Release 1998) R99 (Release 1999) Rel-4 (Release 4) Rel-5 (Release 5) Rel-6 (Release 6)

<b>Reason for change:</b>	⌘ For IMS interception a corresponding figure, which gives a generic overview of the impact on core networks nodes belonging to the IMS domain, is missing. By the way, some <b>editorial</b> <a href="#">corrections and</a> changes to the whole section have been applied.
<b>Summary of change:</b>	⌘ <ul style="list-style-type: none"> <li>- Introduce term IMS in the abbreviation list</li> <li>- Correction of figures 1a, 1b, 1c</li> <li>- Addition of figure 1d: IMS Intercept configuration</li> </ul>
<b>Consequences if not approved:</b>	⌘ Readers of the document may be unaware about the interception impact concerning IMS.

<b>Clauses affected:</b>	⌘ 3.2; 4						
<b>Other specs affected:</b>	<table border="1" style="display: inline-table; border-collapse: collapse;"> <tr> <td style="text-align: center;">Y</td> <td style="text-align: center;">N</td> </tr> <tr> <td style="text-align: center;"><input type="checkbox"/></td> <td style="text-align: center;"><input checked="" type="checkbox"/></td> </tr> </table> Other core specifications	Y	N	<input type="checkbox"/>	<input checked="" type="checkbox"/>	⌘	
Y	N						
<input type="checkbox"/>	<input checked="" type="checkbox"/>						
	<table border="1" style="display: inline-table; border-collapse: collapse;"> <tr> <td style="text-align: center;"><input type="checkbox"/></td> <td style="text-align: center;"><input checked="" type="checkbox"/></td> </tr> </table> Test specifications	<input type="checkbox"/>	<input checked="" type="checkbox"/>	⌘			
<input type="checkbox"/>	<input checked="" type="checkbox"/>						
	<table border="1" style="display: inline-table; border-collapse: collapse;"> <tr> <td style="text-align: center;"><input type="checkbox"/></td> <td style="text-align: center;"><input checked="" type="checkbox"/></td> </tr> </table> O&M Specifications	<input type="checkbox"/>	<input checked="" type="checkbox"/>	⌘			
<input type="checkbox"/>	<input checked="" type="checkbox"/>						
<b>Other comments:</b>	⌘						

# \*\*\* FIRST MODIFICATION \*\*\*

## 3.2 Abbreviations

For the purposes of the present document, the following abbreviations apply:

3GPP MS	3rd Generation Mobile Communication System
3G GGSN	3rd Generation Gateway GPRS Support Node
3G GSN	3rd Generation GPRS Support Node (GGSN/SGSN)
3G MSC	3rd Generation Mobile Switching Center
3G SGSN	3rd Generation Serving GPRS Support Node
3G UMSC	3rd Generation Unified Mobile Switching Centre
ADMf	Administration Function
CC	Content of Communication
DF	Delivery Function
ECT	Explicit Call Transfer
GPRS	General Packet Radio Service
HI	Handover Interface
IA	Interception Area
ICEs	Intercepting Control Elements (3G MSC Server, 3G GMSC Server, P-CSCF, S-CSCF, SGSN, GGSN)
<a href="#"><u>IMS</u></a>	<a href="#"><u>IP Multimedia Core Network Subsystem</u></a>
INEs	Intercepting Network Elements (3G MSC Server, 3G GMSC Server, P-CSCF, S-CSCF, SGSN, GGSN, MGW)
IP	Internet Protocol
IRI	Intercept Related Information
LDI	Location Dependent Interception
LEA	Law Enforcement Agency
LEMF	Law Enforcement Monitoring Facility
RA	Routing Area
RAI	Routing Area Identity
SAI	Service Area Identity
TEL URL	"tel" URL, as defined in [9]

\*\*\* SECOND MODIFICATION \*\*\*

## 4 Functional architecture

The following figures contain the reference configuration for the lawful interception. The circuit-switched configuration is shown in figure 1a. The packet-switched configuration is shown in figure 1b. [Intercept configurations for HLR and IMS are shown in figures 1c and 1d.](#) The various entities and interfaces are described in more detail in the succeeding subclauses.

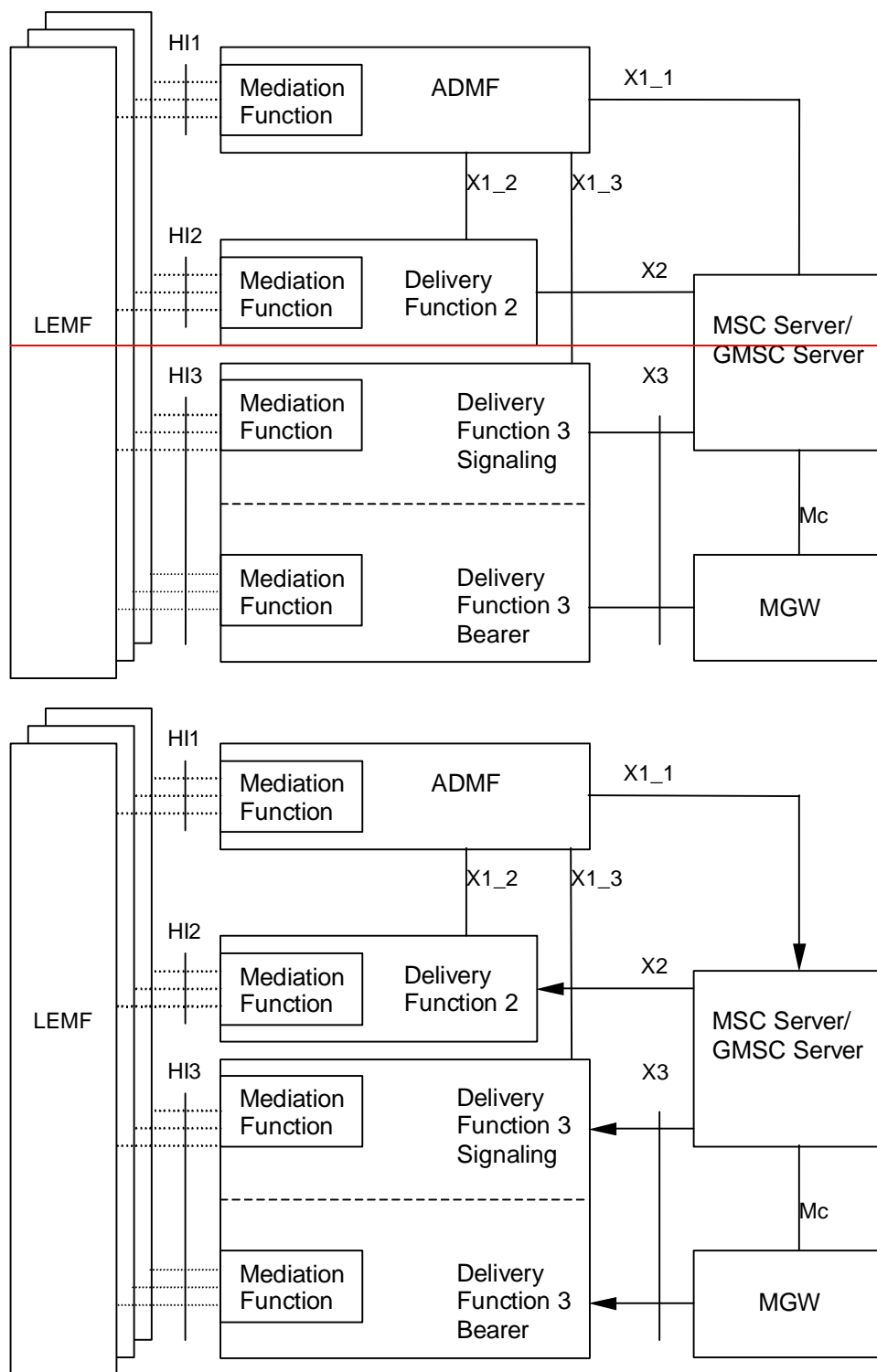
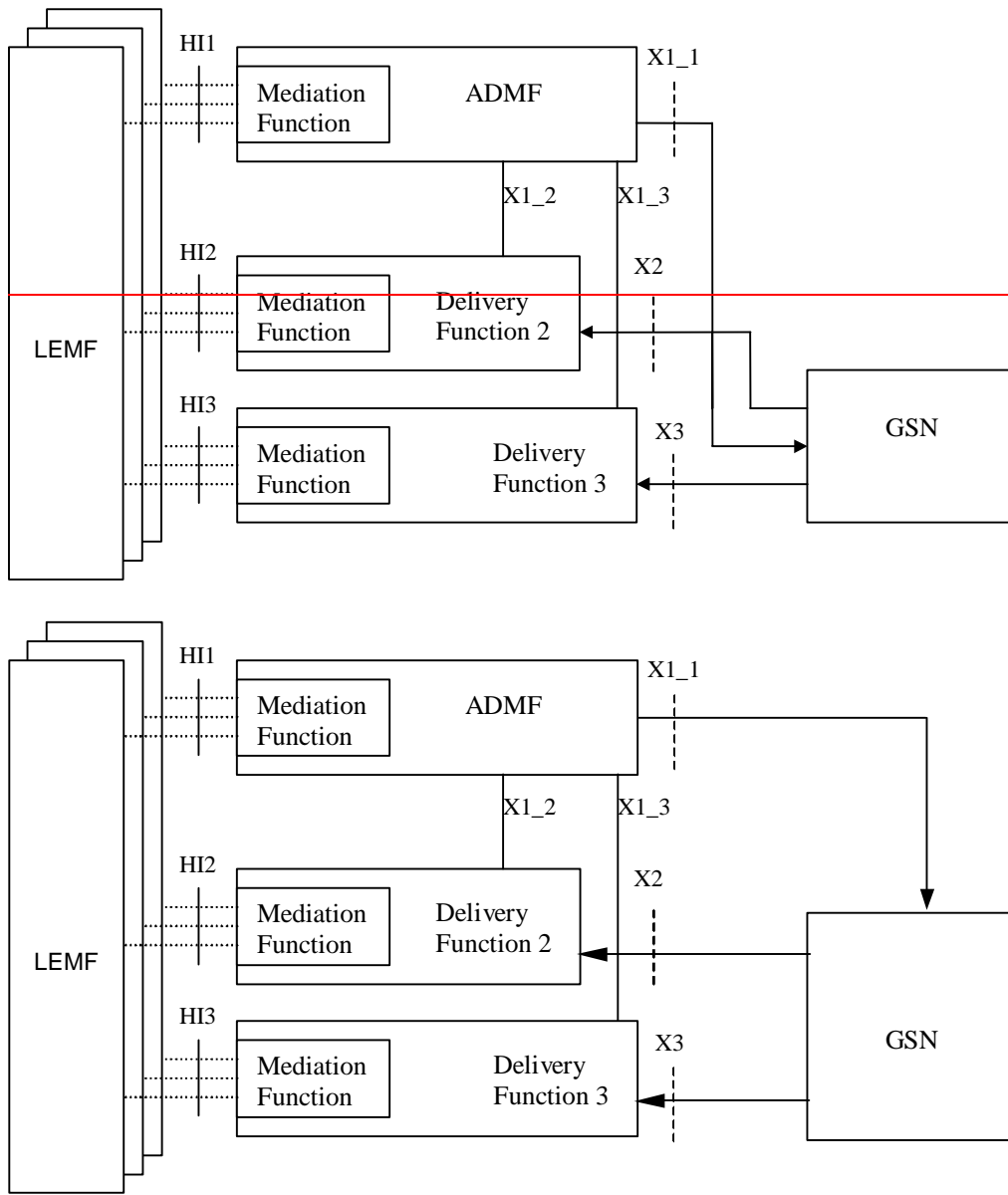
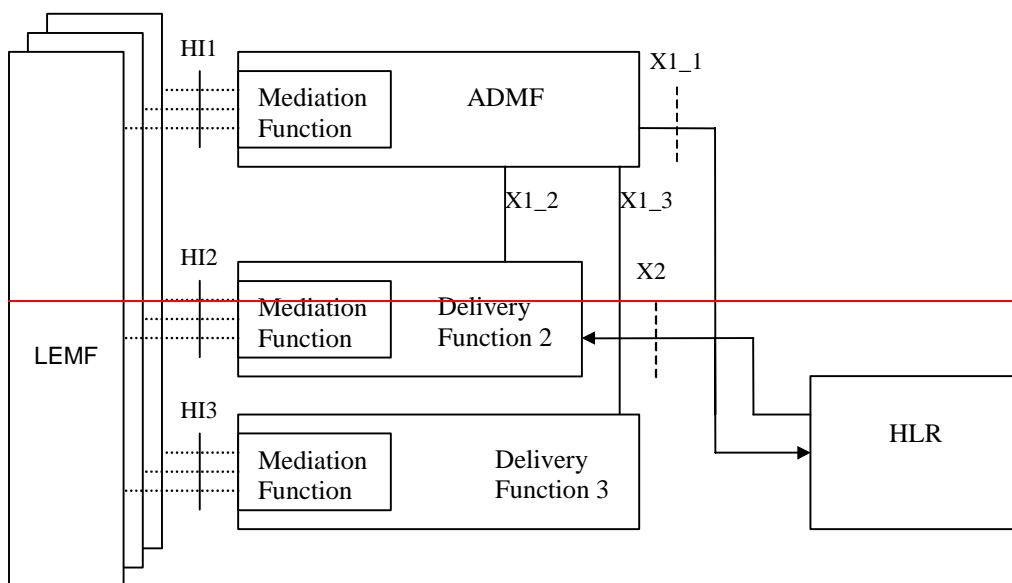
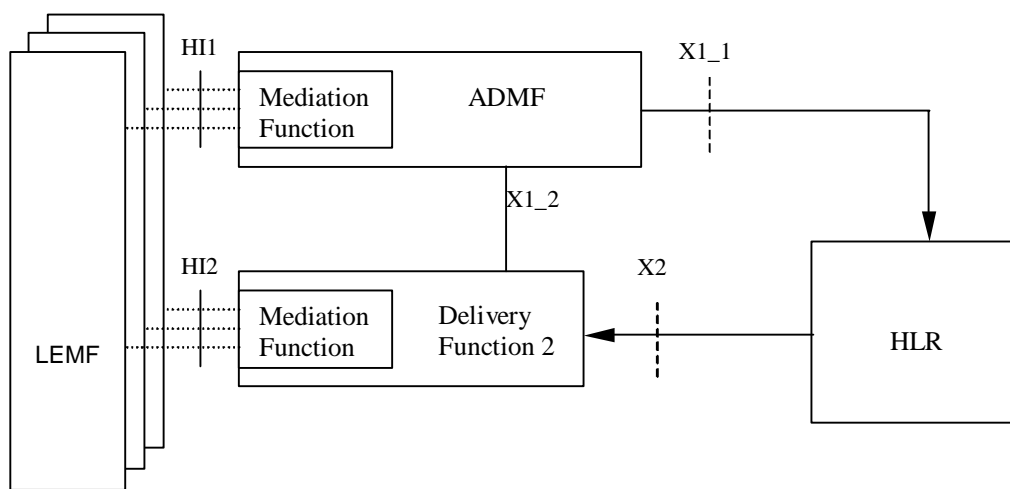

Figure 1a: Circuit switched intercept configuration

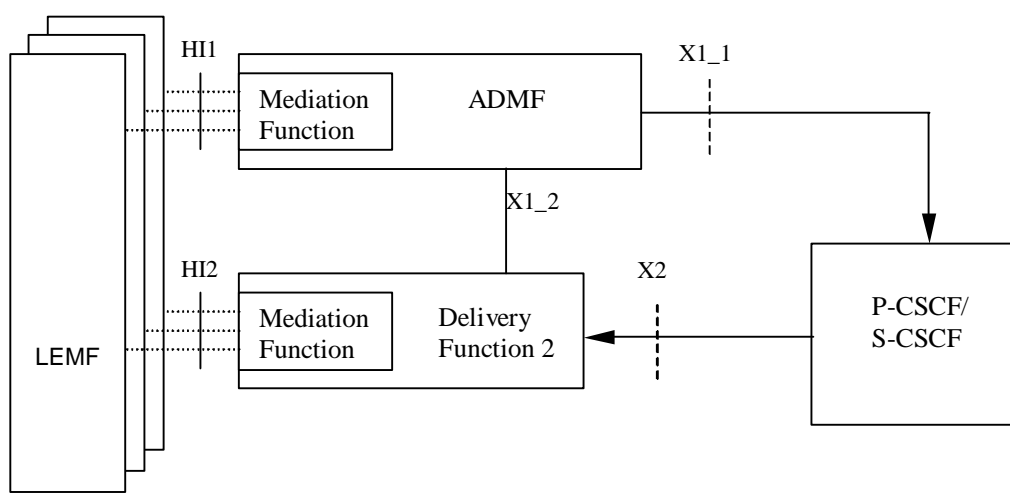

**Figure 1b: Packet Switched Intercept configuration**





**Figure 1c: HLR Intercept configuration**



**Figure 1d: IMS-CSCF Intercept configuration**

The reference configuration is only a logical representation of the entities involved in lawful interception and does not mandate separate physical entities. This allows for higher levels of integration.

Regional Mediation Functions, which may be transparent or part of the administration and delivery functions, are used to convert information on the HI1, HI2 and HI3 interfaces in the format described in various national or regional specifications. For example, if ES 201 671 or J-STD-25 is used, then the adaptation to HI1, HI2 and HI3 will be as defined in those specifications.

**DF3 is responsible two primary functions:**

- Call Control (Signaling) for the intercepted product; and
- Bearer Transport for the intercepted product.

**HI3 is the interface towards the LEMF. It must be able to handle the signalling and the bearer transport for the intercepted product. LEMF can be located within the 3G network or can be in any other network.**

There is one Administration Function (ADMF) in the network. Together with the delivery functions it is used to hide from the 3G ICEs that there might be multiple activations by different Law Enforcement Agencies (LEAs) on the same target. The administration function may be partitioned to ensure separation of the provisioning data from different agencies.

**The HI2 and HI3 interfaces represent the interfaces between the LEA and two delivery functions. The delivery functions are used:**

- to distribute the Intercept Related Information (IRI) to the relevant LEA(s) via HI2 (based on IAs, if defined);

~~— to distribute the Content of Communication (CC) to the relevant LEA(s) via HI3 (based on IAs, if defined).~~

See the remaining sections of this document for definitions of the X1\_1, X1\_2, X1\_3, X2 and X3 interfaces.

Interception at the Gateways is a national option.

For figure 1a DF3 is responsible two primary functions:

- Call Control (Signalling) for the Content of Communication (CC); and
- Bearer Transport for the CC.

HI3 is the interface towards the LEMF. It must be able to handle the signalling and the bearer transport for CC. LEMF can be located within the 3G network or can be in any other network.

For figure 1a and 1b the HI2 and HI3-interfaces represent the interfaces between the LEA and two delivery functions. The delivery functions are used:

- to distribute the Intercept Related Information (IRI) to the relevant LEA(s) via HI2 (based on IAs, if defined);
- to distribute the Content of Communication (CC) to the relevant LEA(s) via HI3 (based on IAs, if defined).

For figures 1c and 1d the HI2 interface represents the interface between the LEA and the delivery function. The delivery function is used to distribute the Intercept Related Information (IRI) to the relevant LEA(s) via HI2.

NOTE 1: With reference to fig. 1c, CC interception does not apply to HLR.

NOTE 2: For IMS, figure 1d relates to the provision of IRI for SIP messages handled by the CSCF. Interception of CC for this case can be done at the GSN under a separate activation and invocation, according to the architecture in Figure 1b (see also section 7.A.1).