

Title: LS on “IMS messaging, Group management and Presence work overlap between 3GPP and OMA

Source: SA1
To: SA2, SA3, CN1
Cc: SA, CN

Contact Person:
Name: Michele Zarri
Tel. Number: +44 79 3200 2114
E-mail Address: michele.zarri@t-mobile.co.uk

Attachments: S1-040151

1. Overall Description:

SA1 had a joint meeting with OMA REQ in Innsbruck on the 13th of January. The joint meeting identified that there is overlapping work on Presence, IMS Messaging, and Group Management between OMA and 3GPP. SA1 is concerned about overlapping work leading to duplication with the potential for market fragmentation. Accordingly, SA1 believes that 3GPP needs to consider how to coordinate work with OMA on these work items as soon as possible.

SA1, SA2, SA3, and CN1 need to consider which aspects of the current work on these three work items should continue to be developed in 3GPP, and which aspects can be regarded as service enablers and therefore (from Rel-7 onwards) should be specified in OMA. SA1 believes that an approach similar to that agreed for future work of MMS, could also be taken for these three work items. That is, the cellular system specific aspects are developed in 3GPP while the service enabler aspects are developed in OMA.

As a general principle, SA1 requires that if any work currently undertaken by 3GPP is to be continued by OMA, it must be backwards compatible. Also, SA1 is concerned about maintaining the overall integrity of the 3GPP system, which must be taken into consideration when evaluating how to split the work.

Finally, SA1 would also like to make SA2, SA3, and CN1 aware of the intended usage of the IMS in OMA described in the attached document and presented during the joint meeting. The attachment also contains an OMA Technical Report on the use of IMS. This information is helpful in understanding what the relationship should be between the two organisations with regards to the IMS.

2. Actions

SA2, SA3, CN1:

SA1 invites SA2, SA3, and CN1 to study and make proposals on how the work on Presence, IMS Messaging and Group management could be split between the two organisations from release 7 onwards.

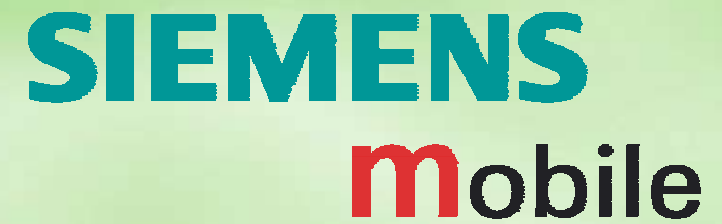

IMS in OMA

Presentation at 3GPP SA1 joint meeting
with OMA REQ,
13th of January 2004,
Manfred Leitgeb, Siemens

Motivation

- **OMA recognises that IMS provides a globally standardised SIP architecture that addresses the needs of mobile operators**
- **Recommendations have been created on how OMA shall treat the IMS, which are**
 - Consider IMS architecture and its capabilities as an option for implementations of OMA Service Enablers. If IMS is leveraged then these service enablers shall :
 - use the inherent IMS mechanisms, e.g. security, authentication and QoS
 - use IMS charging mechanisms
 - Develop specific Service Enablers that can interface with the IMS
 - OMA service enablers should not result in different behaviour at the applications level depending on the underlying SIP based network
 - The OMA architecture may have to expose IMS-based enablers to authorized third parties



Benefits of utilizing IMS

- **Continuity of the standardization process from 3GPP and 3GPP2 exploiting the already defined IMS architecture and focusing on service enablers specification.**
- **Facilitate and accelerate the service definition process within OMA by reutilising IMS Service Capabilities.**
- **Avoid duplication of work between standards bodies that may lead the creation of alternative architecture**



Gaps and overlaps of specification work

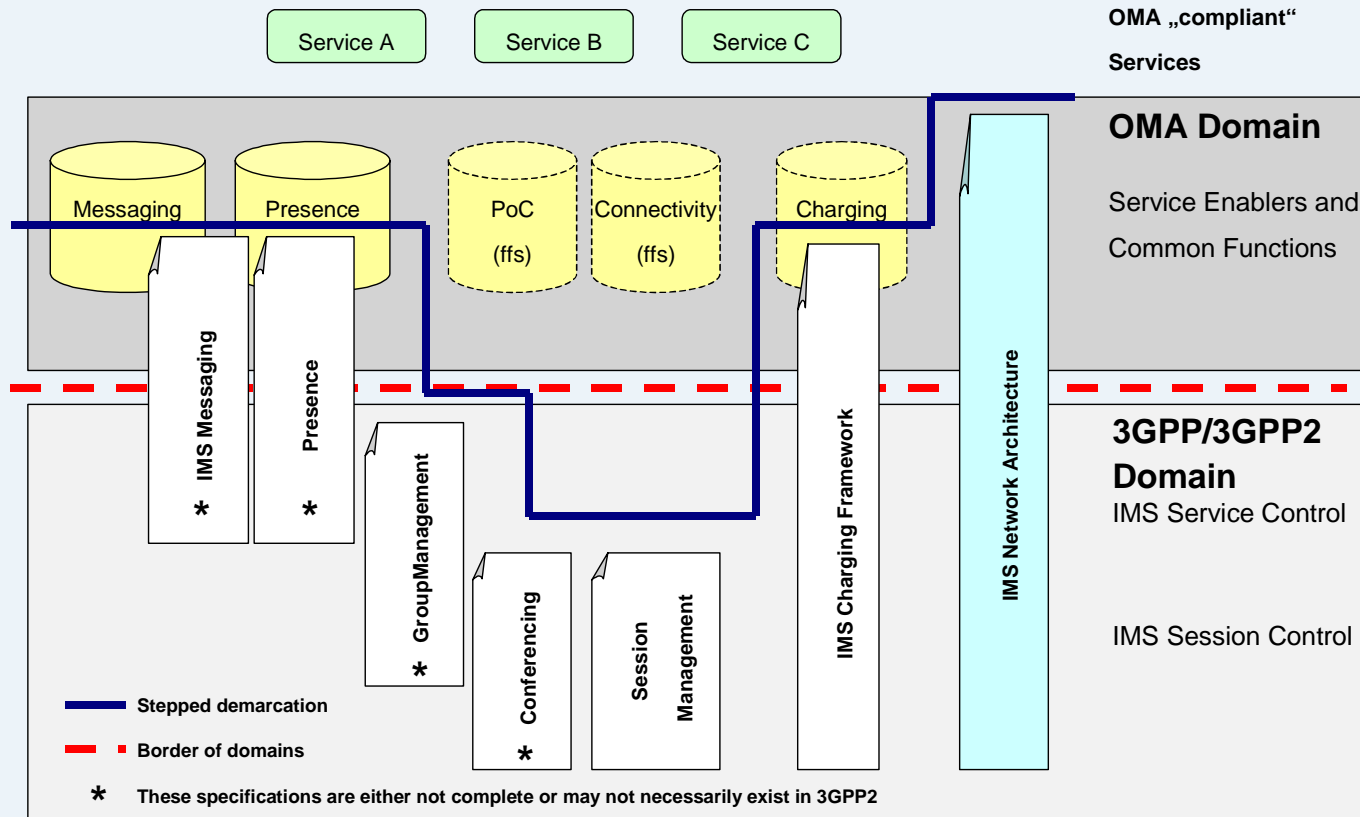

- The degree of overlap varies and needs to be minimized
 - Establish procedures to allow IMS and OMA service enablers to evolve independently
 - Aim at a clear and universally applicable demarcation of working areas

Relation between IMS capabilities and OMA service enablers

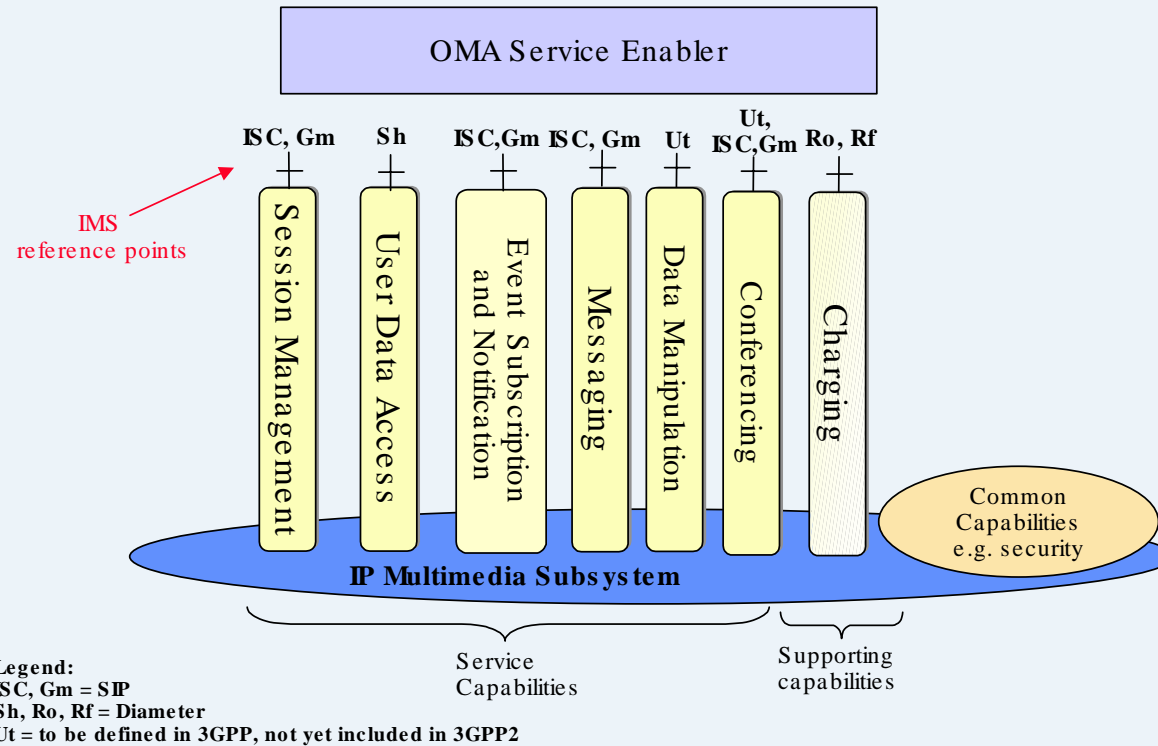

■ IMS capabilities exposed by reference points

- **ISC** and **Gm**, for Session Management, Messaging, Conferencing, Notification and Event Subscription
- **Sh**, for User Data Access
- **Ut**, for Conferencing and Data Manipulation
- **Ro** and **Rf**, for Charging

Initiation of work item „IMS in OMA“

- **Guidance and support for OMA WGs that specify OMA service enablers based on IMS**
- **Development of normative specifications**
 - Ensure consistent use of IMS capabilities by OMA service enablers
 - Maximise reuse of IMS capabilities to prevent fragmentation of standards
- **Work Item is supported by 21 companies**



Work Item tasks and deliverables

- **Task 1 – How can OMA service enablers be developed to use IMS**
 - Describe the relevant capabilities provided by IMS
 - Create architectural picture to illustrate how IMS interfaces with current OMA service enablers and future OMA Service Environment (incl. reference points, protocols,...)
 - Determine the relation between OMA common functions and relevant IMS capabilities (e.g. security, authentication, charging)

Deliverable 1 – Specification for the usage of IMS in OMA

- **Task 2 – 3GPP/3GPP2 collaboration**
 - Establish detailed work split plan related to the exploitation of IMS capabilities between OMA and 3GPP/3GPP2 on architectural level – contribute to work split activity undertaken by REQ
 - Determine the relation between OMA service enabler releases and 3GPP/3GPP2 IMS releases

Deliverable 2 – Release work plan for OMA service enablers and corresponding 3GPP/3GPP2 releases



Collaboration between OMA and 3GPP

- As far as relevant for IMS based OMA Service Enablers, OMA shall be able to put requirements on 3GPP IMS
- The existing relation between IETF and 3GPP shall be used for SIP extensions requested by OMA



WORK ITEM DOCUMENT

Title: Utilization of IMS capabilities
Registered Name: IMS in OMA
Assigned Number: 0076

Public OMA Confidential

1 Description

Description and Objectives of Work to be undertaken (including Justification and Use Cases):

The intent of this work item is not to mandate the use of IMS for service enablers, but will define how OMA service enablers shall make use of capabilities provided by the 3GPP and 3GPP2 IP Multimedia Subsystem (IMS) when IMS is used. The specifications shall guide and support the development of service enablers utilizing IMS capabilities.

In general the IMS enables the realization of IP Multimedia Services. Being the only globally standardized SIP based architecture the IMS provides an architecture that addresses the needs of mobile operators in terms of session management, security, mobility, QoS and charging.

Currently the development of service enablers, that could take advantage of the IMS capabilities, is in progress in some OMA working groups (e.g. PAG, POC). Other OMA working groups might consider utilizing IMS specifications in the future (e.g. MWG, SEC). Leveraging IMS capabilities in the OMA Service Environment can benefit the mobile industry in the following ways:

- o Maintain continuity of the standardization process from 3GPP and 3GPP2 exploiting the already defined IMS capabilities and focusing on service enablers specification.
- o Facilitate and accelerate the service enabler definition process within OMA by reutilising IMS Capabilities.
- o Avoid duplication of work between standards bodies that may lead to the creation of alternative architecture.
- o Protect the heavy investments in the standardization efforts and product development of the IMS.

In order to prevent fragmentation of standards and maximize the reuse of 3GPP and 3GPP2 IMS capabilities and mechanisms this work item shall ensure that the relevant service enablers make consistent use of the IMS capabilities.

Following the principle recommendations given in OMA-TR_IMSinOMA-V1_0-20030912-A this work item aims at providing comprehensive specifications on how IMS capabilities shall be used by OMA service enablers. These activities shall be initially focused on IMS capabilities supporting existing work items like PoC, IM and Presence. The work will expand as new relevant work items appear. The tasks to realize this should be organized as following:

Task 1) Determine how OMA service enablers can be developed to use IMS capabilities

- o Describe the relevant capabilities that IMS provides and identify those capabilities that can be utilized by OMA service enablers.
- o Provide an architectural picture to illustrate how IMS interfaces with the current OMA service enablers and future OMA service environment (OSE).
- o Determine the reference points and protocols an OMA service enabler shall interface with the IMS.
- o Determine the relation between potential OMA common functions and common- / supporting IMS capabilities (e.g. security, authentication, charging) and work with the Requirement working group and Architecture working group to ensure that the recommended common functions match IMS capabilities, where applicable.

Task 2) 3GPP / 3GPP2 collaboration

- o Prepare a detailed work split plan on architectural level related to the exploitation of IMS capabilities between OMA service enablers and 3GPP/3GPP2. This plan will be contributed to the OMA, and 3GPP/3GPP2 work split activity being undertaken by OMA Requirements group.

USE OF THIS DOCUMENT BY NON-OMA MEMBERS IS SUBJECT TO ALL OF THE TERMS AND CONDITIONS OF THE USE AGREEMENT (located at <http://www.openmobilealliance.org/UseAgreement.html>) AND IF YOU HAVE NOT AGREED TO THE TERMS OF THE USE AGREEMENT, YOU DO NOT HAVE THE RIGHT TO USE, COPY OR DISTRIBUTE THIS DOCUMENT.

THIS DOCUMENT IS PROVIDED ON AN "AS IS" "AS AVAILABLE" AND "WITH ALL FAULTS" BASIS.

- o Determine the relation between relevant OMA service enabler releases and 3GPP/3GPP2 IMS releases and ensure these linkages are documented in the OMA Release Planning work program.

Deliverable(s):

The deliverables from this work item will provide the guidelines and include:

Task 1) Specifications or other normative documents for the usage of IMS in OMA

Task 2) Release work plan for OMA service enabler releases and their corresponding 3GPP/3GPP2 releases, which will be submitted to the OMA Release Planning work program.

Throughout the work, liaison statements and change requests will be issued as needed.

Existing Specifications or Documents Affected:

The existing specifications include (list might not be complete):

- OMA Service Enablers
- 3GPP specifications for IMS
- 3GPP2 specifications for IMS

Linked Work Items:

- WI-0028 OMA SIP/SIMPLE IMPS service definition
- WI-0043R1 Push to talk over Cellular (PoC)
- WI-0062 Interfaces for Common functions
- WI-0056 Execution Policy Enforcement

Linked Affected OMA Groups and External For a

- OMA POC, PAG, MWG, LOC and SEC
- 3GPP SA WG1, SA WG2 and CN WG1
- 3GPP2 TSG-X WG3 and TSG-S WG4

2 Impacts

| Service Requirements | | | | Arch | Charging | Security | Privacy | IOT |
|----------------------|-----------|---------|--------|------|----------|----------|---------|-----|
| Smart Card | Terminals | Servers | Access | | | | | |
| X | X | X | X | X | X | X | X | X |

Service Impacts:

Concerning Location Services there might be an interaction between Services Enabler specified within OMA and capabilities provided by IMS.

Architecture Impacts:

Dependent of the results, adaptations to the OMA service enabler architectures may apply.

Charging/Billing Impacts:

The utilization of the IMS charging framework might influence the definition of an OMA common charging function.

Security Impacts:

There might be an interaction between security mechanisms defined within OMA and provided by IMS.

Privacy Impacts:

This area might be impacted by the privacy work done in OMA REQ.

IOT Impacts:

In case there are normative elements in the specification those need to be tested for interoperability, work will be undertaken in the area of IOP.

3 Document History

3.1 Approved Versions

| Version | Date | Notes |
|---------|-------------|--|
| <td> | xx mmm yyyy | <provide info related to approval by TP> |

3.2 Draft Version 1.0 Revisions

| Date | Notes |
|-------------|--|
| 06 Oct 2003 | Initial version submitted to ARCH F2F (Stockholm, 14-16.10.2003) for information |
| 15 Oct 2003 | Enhancements based on comments provided at ARCH F2F (Stockholm, 14-16.10.2003) |
| 20 Oct 2003 | Editorial enhancements |
| 29 Oct 2003 | Editorial enhancements |
| 13 Nov 2003 | Sprint provided additional edits to relieve their concern on the work item |



Technical report on the usage of 3GPP/3GPP2 IMS in OMA

Version 1.0 12–September 2003

Open Mobile Alliance
OMA-TR_IMSinOMA-V1_0-20030912-A

Use of this document is subject to all of the terms and conditions of the Use Agreement located at <http://www.openmobilealliance.org/UseAgreement.html>.

Unless this document is clearly designated as an approved specification, this document is a work in process, is not an approved Open Mobile Alliance™ specification, and is subject to revision or removal without notice.

You may use this document or any part of the document for internal or educational purposes only, provided you do not modify, edit or take out of context the information in this document in any manner. Information contained in this document may be used, at your sole risk, for any purposes. You may not use this document in any other manner without the prior written permission of the Open Mobile Alliance. The Open Mobile Alliance authorizes you to copy this document, provided that you retain all copyright and other proprietary notices contained in the original materials on any copies of the materials and that you comply strictly with these terms. This copyright permission does not constitute an endorsement of the products or services. The Open Mobile Alliance assumes no responsibility for errors or omissions in this document.

Each Open Mobile Alliance member has agreed to use reasonable endeavours to inform the Open Mobile Alliance in a timely manner of Essential IPR as it becomes aware that the Essential IPR is related to the prepared or published specification. However, the members do not have an obligation to conduct IPR searches. The declared Essential IPR is publicly available to members and non-members of the Open Mobile Alliance and may be found on the “OMA IPR Declarations” list at <http://www.openmobilealliance.org/ipr.html>. The Open Mobile Alliance has not conducted an independent IPR review of this document and the information contained herein, and makes no representations or warranties regarding third party IPR, including without limitation patents, copyrights or trade secret rights. This document may contain inventions for which you must obtain licenses from third parties before making, using or selling the inventions. Defined terms above are set forth in the schedule to the Open Mobile Alliance Application Form.

NO REPRESENTATIONS OR WARRANTIES (WHETHER EXPRESS OR IMPLIED) ARE MADE BY THE OPEN MOBILE ALLIANCE OR ANY OPEN MOBILE ALLIANCE MEMBER OR ITS AFFILIATES REGARDING ANY OF THE IPR'S REPRESENTED ON THE “OMA IPR DECLARATIONS” LIST, INCLUDING, BUT NOT LIMITED TO THE ACCURACY, COMPLETENESS, VALIDITY OR RELEVANCE OF THE INFORMATION OR WHETHER OR NOT SUCH RIGHTS ARE ESSENTIAL OR NON-ESSENTIAL.

THE OPEN MOBILE ALLIANCE IS NOT LIABLE FOR AND HEREBY DISCLAIMS ANY DIRECT, INDIRECT, PUNITIVE, SPECIAL, INCIDENTAL, CONSEQUENTIAL, OR EXEMPLARY DAMAGES ARISING OUT OF OR IN CONNECTION WITH THE USE OF DOCUMENTS AND THE INFORMATION CONTAINED IN THE DOCUMENTS.

© 2003 Open Mobile Alliance Ltd. All Rights Reserved.

Used with the permission of the Open Mobile Alliance Ltd. under the terms set forth above.

This document is available online in PDF format at <http://www.openmobilealliance.org/document.htm>.

Known problems associated with this document are published at <http://www.openmobilealliance.org/>.

Comments regarding this document can be submitted to the Open Mobile Alliance™ in the manner published at <http://www.openmobilealliance.org/documents.html>

Contents

| | |
|--|-----------|
| 1. SCOPE | 4 |
| 2. REFERENCES | 5 |
| 2.1 NORMATIVE REFERENCES | 5 |
| 2.2 INFORMATIVE REFERENCES | 5 |
| 3. TERMINOLOGY AND CONVENTIONS | 6 |
| 3.1 CONVENTIONS | 6 |
| 3.2 DEFINITIONS | 6 |
| 3.3 ABBREVIATIONS | 7 |
| 4. INTRODUCTION | 8 |
| 5. BACKGROUND TO IMS ARCHITECTURE | 9 |
| 6. SCOPE OF IP MM BOF | 10 |
| 6.1 PROBLEM STATEMENT | 10 |
| 6.2 OBJECTIVES AND GOALS | 10 |
| 7. GENERAL ASPECTS | 11 |
| 7.1 PRESENT OMA WG ACTIVITIES WITH RELATION TO IMS | 11 |
| 7.2 POTENTIAL IMPACT ON OMA WG ACTIVITIES RELATED TO IMS | 11 |
| 7.3 IMS RELATED WORK SPLIT BETWEEN 3GPP/3GPP2 AND OMA | 11 |
| 7.4 BENEFITS OF UTILIZING IMS | 13 |
| 7.5 CONCLUSIONS ON GENERAL ASPECTS | 13 |
| 8. TECHNICAL ASPECTS | 14 |
| 8.1 GENERAL VIEW ON OSE AND IMS (SERVICE PROVISIONING ARCHITECTURE) | 14 |
| 8.2 DETERMINATION OF SPECIFIC IMS CAPABILITIES | 15 |
| 8.2.1 Service Capabilities..... | 15 |
| 8.2.2 Supporting Capabilities..... | 15 |
| 8.2.3 Common Capabilities..... | 15 |
| 8.3 IMS RELATION TO OMA SERVICE ENABLERS | 15 |
| 8.3.1 IMS Enablers Relevant to OMA | 16 |
| 8.3.2 IMS Interfaces Exposed to OMA | 16 |
| 8.3.3 IMS Interfaces within the Scope of OMA..... | 16 |
| 8.4 CONCLUSIONS ON TECHNICAL ASPECTS | 17 |
| 9. RECOMMENDATIONS OF THIS REPORT | 18 |
| 9.1 GENERAL GUIDELINES AND REQUIREMENTS | 18 |
| 9.2 WORKING AREAS AND ALLOCATION TO OMA WGs | 18 |
| 9.3 LIAISON TO EXTERNAL ORGANISATIONS | 18 |
| APPENDIX A. CHANGE HISTORY (INFORMATIVE) | 19 |
| APPENDIX B. IMS TUTORIAL | 20 |
| APPENDIX C. ENTERPRISE CONSIDERATIONS | 22 |

1. Scope

The IP MM BoF has been established to propose how the IMS architecture, as defined by 3GPP and 3GPP2, can be utilised from an OMA perspective.

The scope of this report is to investigate the applicability of IMS capabilities for OMA service enablers and to determine how OMA can benefit from these capabilities, where-possible.

The report concludes with recommendations to OMA Technical Plenary on

- general guidelines and requirements that are applicable when using IMS capabilities
- IMS related working areas and allocation to OMA work groups
- needed liaisons to external organisations

2. References

2.1 Normative References

None

2.2 Informative References

| | |
|--------------------|--|
| [3GPP TR 24.841] | 3GPP TR 24.841, Presence service based on Session Initiation Protocol (SIP); Functional models, information flows and protocol details |
| [3GPP TS 22.141] | 3GPP TS 22.141, Presence service; Stage 1 |
| [3GPP TS 22.250] | 3GPP TS 22.250, IP Multimedia Subsystem (IMS) Group Management; Stage 1 |
| [3GPP TS 22.340] | 3GPP TS 22.340, IP Multimedia Subsystem (IMS) messaging; Stage 1 |
| [3GPP TS 23.002] | 3GPP TS 23.002, Network Architecture |
| [3GPP TS 23.141] | 3GPP TS 23.141, Presence service; Architecture and functional description; Stage 2 |
| [3GPP TS 23.228] | 3GPP TS 23.228, IP Multimedia Subsystem (IMS); Stage 2 |
| [3GPP TS 24.229] | 3GPP TS 24.229, IP Multimedia Call Control Protocol based on SIP and SDP; Stage 3 |
| [3GPP TS 32.200] | Telecommunication management; Charging management; Charging principles |
| [3GPP TS 32.225] | Telecommunication management; Charging management; Charging data description for the IP Multimedia Subsystem (IMS) |
| [3GPP2 S.R0037-0] | IP Network Architecture Model for cdma2000® Spread Spectrum Systems |
| [3GPP2 X.P0013.0] | Multi-Media Domain Overview |
| [3GPP2 X.P0013.10] | IP Multimedia Subsystem (IMS) Sh Interface signaling flows and message contents |
| [3GPP2 X.P0013.11] | Sh interface based on the Diameter protocol |
| [3GPP2 X.P0013.2] | IP Multimedia Subsystem (IMS); Stage-2 |
| [3GPP2 X.P0013.3] | IP Multimedia (IM) session handling; IM call model |
| [3GPP2 X.P0013.4] | IP Multimedia Call Control Protocol based on SIP & SDP; Stage-3 |
| [3GPP2 X.P0013.5] | IP Multimedia (IM) Subsystem Cx Interface; Signaling flows and message contents |
| [3GPP2 X.P0013.6] | Cx Interface based on the Diameter protocol; Protocol details |
| [3GPP2 X.P0013.7] | IP Multimedia Subsystem Charging Architecture and Stage-2 Description |
| [3GPP2 X.P0013.8] | Telecommunications management; Accounting; Accounting data description for the IMS domain |
| [IS-835] | TIA/IS-835, Release C; CDMA200 Wireless IP Network Standard |
| [OSE] | OMA-SERVICE_ENVIRONMENT-V1_0 (Draft) |
| [TIA-41] | TIA/IS-41, Revision D, Cellular Radiotelecommunications Intersystem Operations |

3. Terminology and Conventions

3.1 Conventions

This is an informative document, which is not intended to provide testable requirements to implementations.

IMS versus MMD: The term IMS is used to refer not only to its 3GPP usage, but also to its 3GPP2 meaning as a subsystem of the Multimedia Domain (MMD). 3GPP2 MMD is more than 3GPP IMS. MMD is also the IP transport (layer 3 defined in [IS-835]) and will at some time include the mobility and access authentication/authorization that is currently done by [TIA-41]. However, for the purpose of this document, we will use the acronym “IMS” to refer to both the 3GPP IMS subsystem and the IMS piece of 3GPP2 MMD.

3.2 Definitions

Note the following definitions apply for this TR only.

IMS Common Capability - does not interact directly with the upper layer (i.e. service enablers), but provides support to both service capabilities, supporting capabilities. The common capabilities provide capabilities on which the other capabilities are built, e.g. security, authentication.

IMS Resource Capability Layer– provides bearers defined by parameters, and/or mechanisms needed to realise services. These are within networks and under network control.

IMS Service Capability - is a capability that provides a service to the upper layer, i.e. OMA Service Enablers. Service capabilities can be used as building blocks for service enablers, and services.

IMS Service Capability Layer - separates applications and content, i.e. commercial services, from underlying networks. It comprises IMS Service Capabilities, IMS Supporting Capabilities and IMS Common Capabilities. The Service Capability Layer provides functionality to get services launched, charged for, and maintained in a secure environment.

IMS Supporting Capability - provides a capability that is in a supporting role for service capabilities. Supporting capabilities cannot be used to build services directly, but they can provide support for services built on Service Capabilities.

Service Layer – provides the commercial services to end-users, which make use of network functionalities represented by the IMS Service Capability Layer. It comprises platforms on which content and applications can be hosted and executed.

VAS - a Value Added Service (VAS) is a telecommunication/information service that is offered in addition to and/or in conjunction with a basic telecommunication/data service.

3.3 Abbreviations

| | |
|--------|---|
| AS | Application Server |
| GW | Gateway |
| HSS | Home Subscriber Server |
| IMS | IP Multimedia Subsystem |
| ISIM | IMS Subscriber Identity Module |
| MMD | Multimedia Domain |
| OSA | Open Service Access |
| OSE | OMA Service Environment |
| PoC | Push to talk over Cellular |
| QoS | Quality of Service |
| S-CSCF | Serving Call Session Control Function |
| SIMPLE | SIP for Instant Messaging and Presence Leveraging |
| SIP | Session Initiation Protocol |
| UE | User Equipment |
| USIM | Universal Subscriber Identity Module |

4. Introduction

The telecommunication industry primarily through 3GPP and 3GPP2, has invested heavily in the standardization efforts of an IP Multimedia core network subsystem, known as the IP Multimedia Subsystem, IMS. IMS defines architectures for the usage of Session Initiation Protocol (SIP) and associated protocols as defined by IETF, for a wireless environment and is seen as one of the primary ways to provide real-time and non real-time multimedia services.

OMA is the main industry body for the development of mobile service enabler specifications, supporting interoperable end-to-end mobile services. In cases where OMA is defining applications that use SIP as their access protocol it is highly desirable that OMA's service specifications exploit the environment created by the IMS. OMA has the potential to define service enablers that leverage IMS capabilities in an interoperable way.

This technical report provides an overview of IMS, lists its benefits, and makes recommendations on how OMA could leverage the capabilities offered, whilst at the same time not excluding other deployments.

5. Background to IMS Architecture

IMS provides a fully standardized architecture for the usage of SIP, rather than something different from IETF SIP. In this way it offers Peer-to-Peer capabilities for Multimedia Services providing user reach ability and session management. In addition to this the IMS architecture is not limited to SIP based interfaces, but it also addresses additional functionalities that complete the necessary requirements for service delivery e.g. bearer control, security and charging issues by defining the IMS charging framework with complete protocol set and interfaces. The IMS architecture is optimized for a mobile environment.

The specific solutions that IMS addresses include e.g.:

- Maintaining session state and provides control mechanisms for session re-direction and detection of unreachable user and indications to requesting entities. In addition, IMS defines procedures to detect and recover from the loss of radio bearer.
- A defined relationship between the responsibilities of the home network and the responsibilities of the visited network when any user is roaming.
- A security architecture that allows authentication of the user before they are allowed to use network capabilities.
- A security architecture between network elements. In addition to providing the security elements, this provides the basis for a trust domain which is used by certain SIP extensions. Of major importance, one of these extensions provides for calling/connected line identification, for which the mechanism without using trusted domains is not yet available in IETF.
- A mechanism for differential charging based on content, rather than solely byte counts, and which allows the visited and home networks for roaming users to agree on the charges due to each other.
- A mechanism for policy control by the network operator, such that the network only handles traffic that the user has contracted for.
- A mechanism for ensuring that traffic over the radio interface is kept to a minimum.
- A mechanism for provision of services by third parties, which are required by the regulatory bodies in certain geographic regions.

In the future, use of the IMS architecture guarantees integration with future work on presence, messaging and wireless LAN.

For example, IMS facilitates the easy deployment of the following:

- Generic IP transport layer media session establishment negotiation. Definitions for voice and video media exist in detail, extensibility allows defining new ones. This allows e.g. rich call, or push to talk type of applications.
- Instant messaging
- Generic subscription and notification framework. A definition for presence service exists, extensibility allows defining new packages.

Note that there are IP based multimedia services, like WEB browsing, that may not benefit from IMS capabilities.

For further information related to IMS see Annex B.

6. Scope of IP MM BoF

The scope of IP MM BoF is to propose how OMA could take advantage of the IMS. Currently this has not been investigated adequately.

6.1 Problem statement

The BoF has identified the following issues:

- Reuse of relevant IMS requirements, enablers, functions and reference points into OMA for delivery of value added services has not been investigated in detail.
- OMA has not yet considered how to utilize IMS for specifying Service Enablers.
- OMA to define service enablers and how these enablers could leverage IMS.
- Boundaries and expectations between OMA and 3GPP/3GPP2 are not well defined related to IMS.
- Overall technical picture regarding relation between OMA Service Environment [OSE] and 3GPP/3GPP2's IMS is missing.
- Duplication of effort and possible generation of conflicting standards in OMA and 3GPP/3GPP2 due to overlaps of working areas as follows:
 - OMA Service Enablers, like Presence and IMS Messaging also exists in 3GPP Release 6 specifications but do not exist in 3GPP2's specifications or current plans. Interoperability/interworking between IMS and OMA Service Enablers is not treated sufficiently.
 - OMA Architecture / Framework is intended to provide common functionality related to QoS, Charging, Security, etc. The relation to similar IMS functionality is an open issue.

6.2 Objectives and goals

Currently, within OMA IP Multimedia and SIP-based service enablers are in the process of being defined. In order to prevent fragmentation of standards and maximise reuse of 3GPP/3GPP2 core network IP multimedia subsystem (IMS) service capabilities and network mechanisms, this BoF aims to identify some means to determine how new OMA's IMS-based service enablers using IP protocols should leverage IMS as the de facto IP service enabler standard where applicable. The goal is to gain a comprehensive and common view on how OMA can make use of IMS mechanisms and capabilities. The outcome of this work will facilitate the timely introduction of IP based service enablers and reduce additional costs by leveraging current investments into IMS.

Another objective of the BoF is to recommend the interfaces between IMS and the vertical service protocols and their respective horizontal system interworking requirements. From a technical perspective the relationship (e.g. reference points) and the demarcation (e.g. functional split) between OMA functional entities and IMS functional entities were investigated. It is important to get a clear picture regarding interoperability between both, the OMA Service Environment [OSE] and the relevant parts of IMS Architecture.

The aim of the IP MM BoF is to provide, within this technical report, recommendations to OMA's Technical Plenary (TP) on how to progress IMS issues within OMA. These recommendations and the following activities by OMA working groups are expected to cover the following areas:

- General guidelines regarding the use of IMS within OMA.
- The determination of specific IMS capabilities that are applicable to OMA. This should be based on:
 - Use Cases and Requirements already underway within OMA WGs (e.g. OMA ARCH)
 - Identification of gaps and overlaps comparing OSE and IMS on functional architecture level, like
 - Relationship between authentication/registration in IMS- and OMA-environment.
 - Interaction between IMS charging framework and the charging functionality defined by OMA.
 - Visualisation of possible impacts on 3GPP/3GPP2 IMS specifications. This includes identification of possible new IMS capabilities needed by OMA, which should be developed within 3GPP/3GPP2 IMS.
- Provide a comprehensive list of IMS related activities already treated by OMA WGs.
 - For example PoC (REQ), SIP/SIMPLE (IMPS), Mapping of existing architectures (ARCH)
- Proposed work allocation for OMA WG(s) in order to implement the BoF recommendations.
- As Part of the recommendation, a work item may be produced.

7. General aspects

7.1 Present OMA WG activities with relation to IMS

In the current OMA work plan, there appears to be activity that may be able to take advantage of IMS, in particular in the following working groups:

IMPS: IMPS-Wireless Village and IMPS-SIP/SIMPLE interworking.
 REQ/MAG: Push to talk over Cellular (Poc)

It should be noted that the work in IMPS with respect to SIP/SIMPLE is relatively advanced. By contrast the work in MAG in relation to PoC, is at an early stage.

7.2 Potential impact on OMA WG activities related to IMS

IMS can potentially impact the following WG and Subgroup activities (a non-exhaustive list):

ARCH: Design and specification of OMA Service Environment.
 DM: Additional DM requirements to manage USIM/ISIM.
 LOC: Interactions between IMS and the OMA End-to-end Location Architecture.
 MWS: Interactions between IMS and the Mobile Web Services Framework.
 REQ: Market requirements calling for development of new service enablers employing IMS capabilities.
 SEC: Interactions between IMS (authentication, ISIM) and OMA SEC mechanisms (e.g. On Board Key Generation, attachment of DRM content encryption key to the USIM/ISIM).
 MAG: Interactions between IMS and SIP based Push.

The above mentioned potential IMS impacts should be validated as more information becomes available.

7.3 IMS related work split between 3GPP/3GPP2 and OMA

The IMS related specification work of 3GPP and 3GPP2, for historical reasons, partly overlaps with the work planned or currently underway by OMA. Specifically following specifications are to be mentioned: (list is not exhaustive)

- **IMS Network Architecture** [3GPP TS 23.002, 3GPP2 S.R0037]
 The IMS Network Architecture enables commercial services, to access network functionalities, represented by service capabilities. The overlap is that OMA and its Service Enabler specifications also focus on means to enable commercial services to access network functionalities.
- **IMS Charging Framework** [3GPP TS 32.200, 3GPP TS 32.225, 3GPP2 X.P0013.7, 3GPP2 X.P0013.8]
 The Charging Framework provides means to allow that the usage of IMS capabilities can be charged appropriately. Within OMA the specification of a Charging Functionality (Common Function) is in discussion. Although not agreed within OMA yet, there is a potential overlap to 3GPP/3GPP2 work since aspects like content charging and correlation of charging information are covered by the 3GPP/3GPP2 charging specification.

- **Presence Service** [3GPP TS 22.141, 3GPP TS 23.141, 3GPP TR 24.841, 3GPP2 S.R0062]
The Presence Service in 3GPP provides access to presence information to be made available to other users or services. Whilst the specifications do not cover IMS users exclusively, the architecture to support the presence service is built on SIP signalling using IMS capabilities and principles.
- **IMS Messaging Service** [3GPP TS 22.340, 3GPP2 S.R0061]
IMS Messaging Service allows an IMS user to send and receive messages to other users. IMS messaging services comprise of one or more types: Immediate messaging, Session based messaging and Deferred delivery messaging. This 3GPP specification overlaps with the work of OMA IMPS.
- **IMS Group Management** [3GPP TS 22.250]
The IMS Group Management allows the management of network based groups and is a generic capability that can be utilised together with several different services, like Presence or PoC. Thus this specification potentially overlaps with the work of OMA. Discussion on this topic has been started in 3GPP2.
- **IMS Conferencing** [3GPP TS 23.228]
The IMS conferencing provides means to establish and control IP multimedia sessions with two or more participants. The conferencing capability enables various kinds of services that involve conference like functions, like Gaming and PoC. This specification complements the work of OMA. Discussion on this topic has been started in 3GPP2.

The degree of overlap/complement varies and depends on the particular specification. Thus, it is not possible to introduce a straight demarcation line between OMA and the specification work of 3GPP and 3GPP2. On the contrary, every IMS specification relevant for OMA has to be investigated and consequently a decision is to be made on what parts of a specific IMS specification shall be the basis for the OMA works.

3GPP2 IMS specifications are mainly based on 3GPP release 5 specifications. The enhancements to IMS in 3GPP are currently underway in release 6. Currently 3GPP2 is discussing the inclusion of these enhancements into their specifications. From OMA’s point of view, it would be desirable to have the same functionality from 3GPP and 3GPP2.

The following figure 7-1 provides examples of overlapping/complementing specifications and intends to visualise the present stepped demarcation as mentioned above.

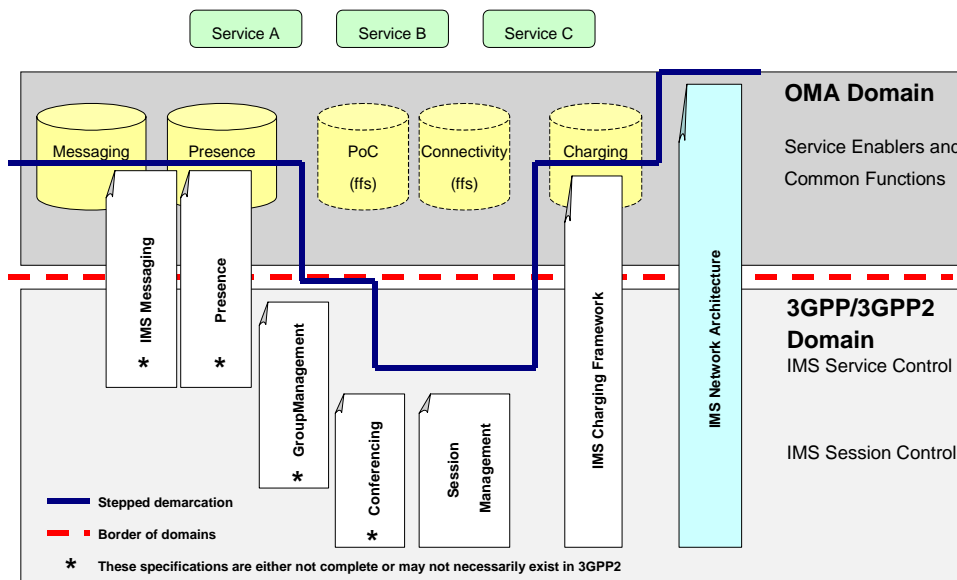

figure 7-1: Visualisation of overlaps of specification work

However, a clear and universally applicable demarcation between OMA and 3GPP/3GPP2 specification work shall be aimed at. This will prevent duplication of work and maximise the mutual benefit of OMA and 3GPP/3GPP2.

Consequently, these will require cooperation between OMA and the 3GPP/3GPP2 to define a technical interface that meets these objectives and an established working relationship between OMA and 3GPP/3GPP2 to allow OMA to insert capability requests into the 3GPP/3GPP2 requirements process.

7.4 Benefits of utilizing IMS

OMA has the ability to bring several advantages to utilizing IMS in the OMA Service Environment. Some of these advantages can be captured as

- Continuity of the standardization process from 3GPP and 3GPP2 exploiting the already defined IMS architecture and focusing on service enablers specification.
- Facilitate and accelerate the service definition process within OMA by reutilising IMS Service Capabilities
- Avoid duplication of work between standards bodies that may lead the creation of alternative architecture

7.5 Conclusions on general aspects

IMS provides an architectural solution for the usage of SIP in 3GPP and 3GPP2 networks. IMS addresses some specific solutions as defined in section 5. However, these specific solutions can be addressed in other methods depending on the specific needs of the Operator. The decision of the Operator to meet their needs outside of IMS specific solution shall not prevent the Operator from utilizing OMA developed service enablers that use the SIP protocol. When developing OMA service enablers it can be assumed that the underlying network provides the same functionality as IMS. Further, OMA may work on service enablers that take advantage of SIP as a protocol but do not require IMS.

Within OMA, there may be activities that could leverage IMS capabilities however if individual working groups in OMA do not communicate or coordinate, an inconsistent view of leveraging IMS may result. It is therefore proposed that Architecture working group act as the overall coordinator advising other working groups how IMS can be leveraged in OMA.

To avoid duplication of work between 3GPP/3GPP2 and OMA, it is recommended that 3GPP/3GPP2 complete all IMS work as originally planned for the current releases (i.e. 3GPP release 6 and equivalent 3GPP2 release). In the event that potential work overlap is not being developed within both 3GPP and 3GPP2 the organizations should be encouraged to align their specifications. If needed, OMA should facilitate this alignment to ensure that the requirements of the whole industry are addressed. This will need to be determined on a case-by-case basis through an evaluation of the market requirements and use cases.

OMA should recommend to 3GPP/3GPP2 that enhancements to IMS Services (e.g. Presence and Messaging) beyond release 6 be undertaken by OMA. However, 3GPP/3GPP2 should retain control of modifications to release 5 and release 6.

Fragmentation of specification should be avoided by ensuring that details of the SIP signalling protocol related to IMS are kept under the control of 3GPP/3GPP2 (i.e. in 3GPP TS 24.229 and 3GPP2 X.P0013.4). Whilst IMS is based on IETF protocols, OMA should convey new IMS requirements to 3GPP and 3GPP2. Overlapping activities with IMS relevance shall be minimized.

8. Technical aspects

8.1 General view on OSE and IMS (Service Provisioning Architecture)

The IMS Service Provisioning Architecture, developed by 3GPP/3GPP2, allows applications, i.e. commercial services, to access capabilities of the IMS. It comprises options for service provisioning, namely SIP-Application Server and OSA Gateway. By nature, this IMS Service Provisioning Architecture is specifically designed for the 3GPP environment.

The OMA Service Environment (OSE), which is being established by OMA, allows commercial services to be built on Service Enablers. The OSE aims at supporting a broad range of, partly yet unknown, commercial services. Thus its focus is more general compared to the IMS Service Provisioning Architecture.

However, from a layered architecture perspective both, the OMA Service Provisioning Architecture, and the 3GPP/3GPP2 IMS Service Provisioning Architecture, to some extent cover the Service Capability Layer as well as the interface towards the Service Layer. This overlap is shown in the following figure 8-1.

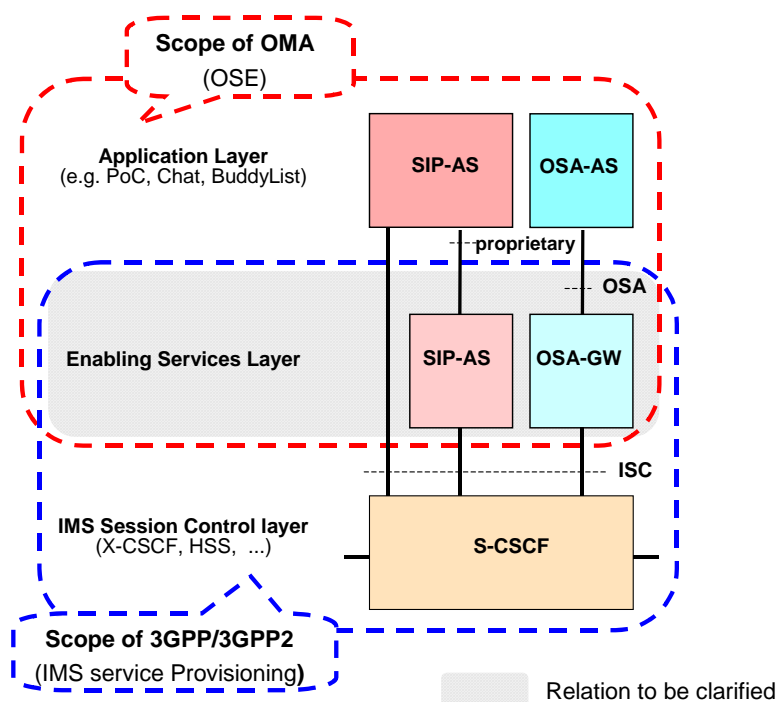

figure 8-1: Layers covered by OSE and IMS Service Provisioning Architecture

At present OMA treats the IMS as a network capability providing IP transport and a source of service enabling functions. OMA works on what it terms “service enablers”, that is, not end to end services, but capabilities that value added services are built on¹. Therefore, any capability and resources that IMS can offer to build value added services should be logically integrated into the OMA environment.

OMA is currently working on the design and specification of a logical service environment, the OMA Service Environment (OSE), within which, certain IMS resources and service enabling functions may be incorporated. Since the OSE is still being developed, its relation to IMS Service Provisioning Architecture is for further study.

¹ A value added service (VAS) provider (VASP) could be a network operator or a 3rd party service provider.

8.2 Determination of specific IMS capabilities

Based on the characteristics of the IMS architecture, the IMS capabilities can be divided into three categories:

- Service capabilities
- Supporting capabilities
- Common capabilities

8.2.1 Service Capabilities

The service capabilities consist of session management, user data access, event subscription and notification, messaging, data manipulation, and conference control.

- **Session management** enables sessions, maintains session state, and provides control mechanisms e.g. redirection or detection of unreachable SIP users and indications to requesting entities.
- **User data access** provides the service enablers the possibility to retrieve user information, e.g. information whether the IMS subscriber is currently reachable or not.
- **Event subscription and notification** capability provides a generic capability for subscribing to and notification of events e.g. user presence and watcher information.
- **Messaging** capability enables the distribution of small multimedia content end-to-end.
- **Data manipulation** (a.k.a. group management) provides capabilities to configure, update and store data related to service enablers, e.g. presence authorization policies and access control lists to groups.
- **Conferencing** provides a set of control capabilities related to conference creation, configuration and management.

8.2.2 Supporting Capabilities

Currently only one supporting capability has been identified - the charging capability. The supporting capabilities can be considered as non-essential to service enablers. However, they do provide additional value by linking service enablers to business logic infrastructure. Examples of such linkage are charging correlations, prepaid and postpaid charging.

8.2.3 Common Capabilities

The third set of capabilities is the IMS internal common capabilities. For example, IMS specifications include secured connections to deliver SIP signaling messages to an end user. The IMS also guarantees that the SIP user has been authenticated and authorized during the registration phase at the IMS level. Hence, the service enablers can rely on users having been authenticated and authorized by the IMS system. In addition, there is a possibility to integrate service level authorization and IP level media treatment, and flexible charging based on signaling transactions and media.

8.3 IMS relation to OMA Service Enablers

The IMS capabilities are shown in figure 8-2. The service and the supporting capabilities are represented as blocks with interfaces to upper layer – in the figure to the OMA Service Enabler. The service capabilities with the different interfaces are shown in the figure in more detail. For instance, the ISC interface is a SIP interface with extended functionality defining how the IMS and the application servers interact with each other. The common capabilities do not have interfaces to the upper layer. They are shown as a separate bubble in the figure 8-2.

As figure 8-2 shows, all service, and support capabilities are relevant to OMA. This means that their usage should be specified in OMA. The usage of common capabilities is out of scope, as they have no interface to the OMA Service Enablers.

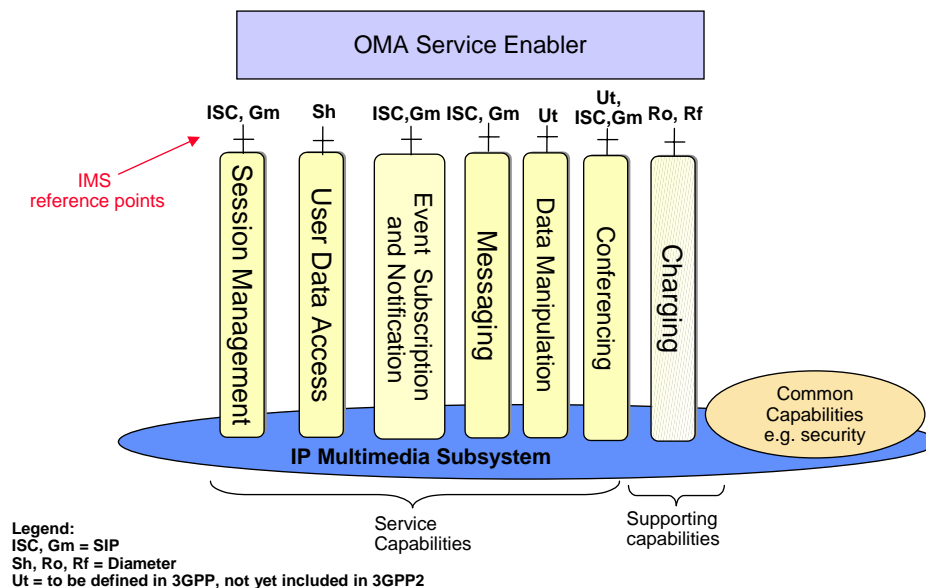

figure 8-2: Relationship between IMS capabilities and OMA

For further information related to IMS interfaces see Annex B.

8.3.1 IMS Enablers Relevant to OMA

Both IMS resources and related reference points are currently under the control of 3GPP/3GPP2, and it is expected to continue.

As shown in figure 8-2, a number of interfaces are exposed to OMA. A division of work control can be made between those Interfaces that are and will continue to be under the control of 3GPP/3GPP2 and those interfaces that currently are under the control of 3GPP/3GPP2 but may be defined by either 3GPP/3GPP2 or OMA.

8.3.2 IMS Interfaces Exposed to OMA

Interfaces that are exposed to OMA but under the control (i.e., documentation, changes, etc.) of 3GPP/3GPP2 are:

- ISC (IMS Service Control Interface)
- Sh (Access to subscriber data)
- Gm (Reference point between UE and the network)
- Ut (Reference point between UE and AS) (Not applicable for 3GPP2)

8.3.3 IMS Interfaces within the Scope of OMA

Necessary service enabler developments are within the scope of OMA and are developed by OMA. Thus, the usage of an interface can be standardized by OMA, but the actual protocol(s) of the interface may be the responsibility of 3GPP/3GPP2, for example, Ut (Reference point between UE and AS).

It is not yet known whether the Ut reference point is a single protocol or multiple protocols. However, if this reference point were to be multiple interfaces/protocols then potentially, the group defining the service enabler may define - in coordination with the owner(s) of the reference point - its own protocol, that is OMA and 3GPP/3GPP2 may define their own service enabler(s) with the corresponding Ut protocol(s).

8.4 Conclusions on technical aspects

IMS have been developed based on the wide-spread technical know-how of the cellular industry. OMA's use case and market requirement driven approach complements this technical experience of 3GPP/3GPP2 on IMS with additional market input. To protect these investments and efforts of the cellular industry OMA should work on service enablers that can leverage existing IMS resources.

When OMA starts to develop applications and service enablers based on IMS capabilities there will be a need for one or more

- Standardised interface(s) between IMS, which is under the control of 3GPP/3GPP2 and the various elements to build services such as service enablers, which are under the control of OMA,
- Mechanism(s) to allow IMS and entities developed by OMA such as service enablers to evolve independently of each other, and
- Mechanism(s) to enable OMA to request features to be included in the IMS to support OMA's technical needs.

These following items should be considered:

- OMA should treat the discussion related to the incorporation of IMS.
- OMA should actively progress the logical mapping of the IMS elements to OMA Service Environment (OSE).
- OMA should investigate on the relation between OSE and IMS service provisioning architecture. The migration from IMS Service Provisioning Architecture towards OSE needs to be developed.

9. Recommendations of this report

As a result of the IP MM BoF work this section provides recommendations to OMA Technical Plenary.

9.1 General guidelines and requirements

When considering IMS based service enablers, this technical report makes the following recommendations:

- OMA recognises that IMS provides a SIP based architecture defined by 3GPP and 3GPP2 that addresses the needs of mobile operators in terms of session management, security, mobility, QoS and charging. At the time being there are no other globally standardised SIP architectures.
- OMA should consider IMS architecture and its capabilities as an option for implementations of OMA Service Enablers. If IMS is leveraged then these service enablers shall :
 - use the inherent IMS mechanisms, e.g. security, authentication and QoS
 - use IMS charging mechanisms
- OMA should identify IMS capabilities realising OMA service enablers.
- OMA should develop specific Service Enablers that can interface to the IMS, can use IMS capabilities and can exploit the resources of their underlying network infrastructure via the IMS.
- Enablers standardised by OMA should not result in different behaviour at the applications level depending on the underlying SIP based network (i.e., IMS or other IETF compliant SIP).
- OMA should assume that any non-IMS SIP based network on which OMA service enablers are based provides the same functionality as IMS.
- The OMA architecture may have to evolve to expose IMS-based enablers to authorized third parties (e.g. enterprises) in a fully functional, manageable and controllable manner that should address and answer the issues described in Annex C. This should be consistent with the way that other OMA enablers are exposed.

9.2 Working areas and allocation to OMA WGs

The OMA Architecture group (or another designated group) should be given the responsibility of overall coordination and the mandate to establish general principles and framework for the use of IMS in OMA.

Once these general principles have been established each working group that develops enablers is responsible for investigating the suitability of IMS capabilities to realise service enablers within their remit. It is recognised that these general principles may take some time to develop. As a result the working groups that were identified in section 7.1 and 7.2 may wish to understand how the enablers they are developing could gain value by utilising IMS following the recommendations of this TR.

In order to minimise the overlapping work, OMA should recommend to 3GPP/3GPP2 that enhancements to IMS Services that are OMA service enablers beyond Release 6 be undertaken by OMA. However, 3GPP/3GPP2 should retain control of maintenance of release 5 and release 6 on IMS and in general the development related to IMS architecture. The precise work split (e.g. Presence and Messaging) has to be developed jointly between OMA and 3GPP/3GPP2.

9.3 Liaison to external organisations

In section 7.5 it has been articulated that OMA and 3GPP/3GPP2 need to cooperate to define a technical, standardised interface between application domains and IMS that allows the OMA applications use IMS without creating dependencies on each other. If OMA identifies new IMS requirements, these should be communicated to 3GPP and 3GPP2. In addition OMA may wish to encourage the continued alignment of IMS in 3GPP and 3GPP2.

Appendix A. Change History (Informative)

| Type of Change | Date | Section | Description |
|---------------------------------|-------------------|---------|--|
| OMA-TR_IMSinOMA-V1_0-20030505-D | 05-May-2003 | | The initial version of this document. Created in IP MM BoF#1 at Loipersdorf. |
| OMA-TR_IMSinOMA-V1_0-20030515-D | 15-May-2003 | | Clean up of styles etc. |
| OMA-TR_IMSinOMA-V1_0-20030519-D | 19-May-2003 | | Enhancements to section "Scope of IP MM BoF" based on comments from ConfCall (2003-05-19) Editorial updates |
| OMA-TR_IMSinOMA-V1_0-20030527-D | 27-May-2003 | | Introduction of new sections as agreed in ConfCall (2003-05-26) Editorial updates |
| OMA-TR_IMSinOMA-V1_0-20030604-D | 04-June-2003 | | Introduction of new sections as agreed in ConfCall (2003-06-02) |
| OMA-TR_IMSinOMA-V1_0-20030610-D | 10-June-2003 | | Output from OMA Atlanta meeting. |
| OMA-TR_IMSinOMA-V1_0-20030707-D | 7-July-2003 | | Output from Sophia Antipolis |
| OMA-TR_IMSinOMA-V1_0-20030709-D | 9-July-2003 | | Editorial enhancements, agreed at Sophia Antipolis |
| OMA-TR_IMSinOMA-V1_0-20030812-D | 12-August 2003 | | Enhancements as agreed in ConfCall (2003-08-04) based on documents (0043R2 and 0045) |
| OMA-TR_IMSinOMA-V1_0-20030819-D | 19-August-2003 | | Enhancements as agreed in ConfCall (2003-08-18) based on documents (0048, 0050 and 0051) |
| OMA-TR_IMSinOMA-V1_0-20030825-D | 25-August-2003 | | Agreed editorial enhancements based on 0046 (Vienna, 2003-08-25) |
| OMA-TR_IMSinOMA-V1_0-20030825-D | 25-August-2003 | | Agreed changes based on 0052, 0058 and 0060 (Vienna, 2003-08-25) |
| OMA-TR_IMSinOMA-V1_0-20030826-D | 26-August-2003 | | Output from Vienna meeting (2003-08-26) |
| OMA-TR_IMSinOMA-V1_0-20030830-D | 30-August-2003 | | Editorial enhancements received on BoF mailing list (2003-08-28) |
| OMA-TR_IMSinOMA-V1_0-20030908-D | 08-September-2003 | | Output from Berlin meeting (2003-0908). Agreed to be sent to OMA TP for approval. |

Appendix B. IMS Tutorial

IP Multimedia Subsystem (IMS) is a Session Initiation Protocol (SIP) based IP multimedia infrastructure that provides a complete architecture and framework for providing multimedia services. This includes security functions (e.g. authentication, authorization), routing, charging, and default codecs. Thus, IMS provides an excellent platform for globally interoperable IP multimedia services - especially in the mobile environment.

The first release of IMS specifications was defined in the 3GPP Release 5. 3GPP2 has also adopted the Release 5 part of their Multimedia Domain (MMD) specifications. IMS has been further enhanced in 3GPP Release 6 to include additional features, e.g. presence, and group management.

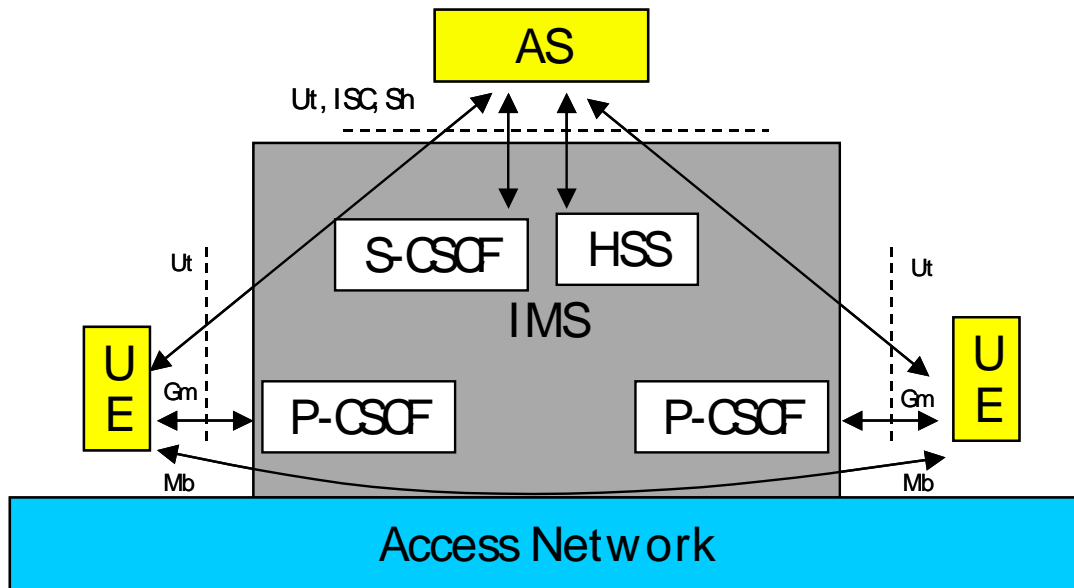

figure B-1: Simplified IMS architecture

The main components of the IMS architecture in the relation to OMA are depicted in figure B.1. The functionality of the elements is as following.

P-CSCF - Proxy Call Session Control Function is the first contact point for the UE. It handles certain SIP related functions (e.g. forwarding of different SIP messages), security related functions (e.g. maintaining security association with the mobile), charging functions, SIP signalling compression/decompression. The P-CSCF can either be in the visited or in the home network.

S-CSCF - Serving CSCF performs the session control and registration services for the UE. It maintains a session state and interacts with service platforms as needed by the network operator for support of the services. Within an operator's network, different S-CSCFs may have different functionalities. The S-CSCF is located at the home network.

HSS – Home Subscriber Server is the master database for a given user. It is the entity containing the subscription-related information to support the network entities actually handling sessions. The HSS is responsible for authenticating, and authorizing the subscriber.

AS - Application Server may host and execute services. It is offering value added IM services resides either in the user's home network or in a third party location. The third party could be a network or a stand-alone AS. The Application Server can influence and impact the SIP session on behalf of the services and it uses the ISC interface to communicate with the IMS. In addition, AS can originate SIP requests behalf of the UE. The AS can be either a SIP application server, or an OSA service capability server, which exhibit the same interface behaviour.

The relevant reference points for OMA are the Gm, Ut, Sh, Mb, and ISC. In addition, there are charging related interfaces Ro, and Rf. These reference points are listed in more detail in the following.

- **Gm – UE-IMS reference point** is between the UE and the first SIP-proxy.
- **Mb – UE-UE reference point** is for IP service access, and is used for user data transport. (Note: the AS can also act as an UE.)
- **ISC – AS –IMS reference point** is between the S-CSCF and an Application Server (AS).
- **Sh – AS-HSS reference point** is between the Application server and the Home Subscriber Server.
- **Ut – UE-AS reference point** is between the UE and the Application Server.
- **Ro, and Rf are reference points** for on-line and off-line charging respectively. They are between the IMS and the charging gateway.

Appendix C. Enterprise considerations

In general the requirements from enterprise environments are treated within OMA. This annex provides some aspects that are relevant for service enablers that use IMS capabilities. These issues need to be further studied when developing IMS based service enablers.

The Challenges of Enterprise Mobilization

Enterprises are stakeholders that behave as:

- Service providers that may:
 - Provide applications with mobile features and sometimes access network to its employees,
 - Aggregate these across numerous service providers and
 - Enjoy a special relationship with their employee that may authorizes them to:
 - Dictate all the conditions (cost, security,) that must be satisfied by all involved service providers and that affect all usage by employees of mobile applications, devices and access.
 - Access employee information (e.g. profile, location, presence, usage, device settings, ...)
 - Impact employee resources (e.g. device provisioning, profile, ...)
 - Provide the technical supports for the end-to-end usage of mobile services by their employee.
 - Provide very specific security constraints on data exchanges, access, usage and life cycle of data and applications (e.g. no intermediate storage, confidentiality)...
- Customers of the IMS SPs (e.g. pay access bill and charges for access enablers; contract the SPs for particular services, access capabilities, support or outsourcing etc...).

As such enterprises have a unique combination of needs, including:

- Challenges to develop, deploy and maintain multi-channel applications that are suitable / optimized to the numerous different mobile channels and devices (e.g. browser type, modality,).
- Challenges to support different connectivity models and network technologies including hotspot, enterprise SIP networks and corporate wireless network.
- Difficulties to support (provisioning, debugging, remote assistance) mobile applications across a disparate set of mobile devices deployed across numerous networks (with different technologies and different service providers).
- Difficulties to develop compelling mobile applications that exploit mobile features based on service enablers controlled by service providers, in a manner that is automatable (discoverable) and repeatable or aggregatable across all service providers that are relevant to the enterprise.
- Huge security concerns
- Cost concerns

Enterprise use of IMS within OMA

It is important to investigate the implications on OMA of relying on IMS for some enablers and how can enterprise applications and enablers be exposed via IMS to allow exchanges of data and signalling between enterprise domains and employees mobile terminals (to and from them).

Today, this can be done in at least two different ways:

- Through the Parlay/OSA gateway
- Through a secure connection between the enterprise and the service provider that deploys the IMS platform (e.g. through the SIP application server).

The underlying OMA architecture may have to evolve to expose IMS-based enablers to authorized third parties in a fully functional, manageable and controllable manner. The resulting architecture for IMS enablers should be suited for secure deployments of applications distributed across multiple domains. It should provide answers to the following questions. Some of these issues may be outside the scope of direct standardization activities.

- How do Parlay/OSA gateways or secure connection approaches fit the OMA architecture to expose enablers to authorized third parties? Alternatively, should OMA provide a new approach to access IMS enablers?
- Are the options, available to expose or access enablers and applications through IMS, providing the necessary level of functionality to support call control, secure multi-media streaming, broadcast and other multimedia data exchanges from the enterprise to the employee's mobile terminals; driven from enterprise applications deployed in the enterprise network?
- Can employees' terminals on IMS networks interface with enterprise mobile applications deployed in the enterprise network to initiate appropriate multi-media exchanges to and from the enterprise domain?
- Is there a standardized way to establish the necessary secure connection between the IMS SP and the enterprise? What is the nature of the secure link? What are the available functionality? How does it relate to securing the streamed data sent to and from the terminal?
- Can the establishment of a relationship between the enterprise and the IMS SP be automated so that enterprise can discover and satisfy the conditions required to access enablers or expose enterprise applications through the IMS in an automatable and repeatable manner.
- Are enterprises expected to behave like an IMS third party provider and advertise their enablers and applications accordingly on the SP IMS network (in the IMS SP registry) and are the enterprises then able to control the security and life cycle of such information?
- What is the impact of enablers based on IMS on existing SIP applications, deployments and infrastructure within enterprises and what is required from existing SIP-based applications or deployments to interact with IMS without any loss of functionality and new security risk and allow:
 - Signalling and controlled multimedia data to be exchanged with employee's mobile terminals
 - Employee's terminal to initiate multimedia exchanges with existing enterprise applications in the enterprise domain.
- At the level of OMA, what are the options to efficiently handle employees based worldwide?
- How do we expect to resolve the SIP extensions introduced with IMS and that are not used nor understood by enterprise SIP deployments and applications: via gateway and message translation or otherwise?
- As IMS prescribes very peculiar field masking, how will an enterprise be able to access the information about its employee that would be available or easily added in an enterprise or internet deployment?
- How can enterprise authorize their employee to access secure data when relying on IMS-based enablers?

The recommendations presented in this report are based on the assumptions that the needs of enterprises can be appropriately met by the OMA architecture that will be developed for IMS-based OMA enablers.