

27 - 30 November, 2001

Sophia Antipolis, France

Source: Hutchison 3G UK

Title: Update on changes to MAPsec Release 5

Document for: Information

Agenda Item:

The following are the non-editorial changes made between TS 33.200 (Rel-5) v0.1.0 and TS 33.200 (Rel-5) v0.1.1. These take account most of the comments that were sent to me.

- Security domain = PLMN (throughout document)
- Section 1: Added sentence to Scope to state that automatic key management is included.
- Section 2: Updated MAPsec DoI reference.
- Title section 5.1 added “Properties and Tasks of ...”
- Section 4: Reworded Ze interface definition to include the carrying of security policy information. Similar changes in second bullet of Section 5.1.
- Section 5.1: examples of information in some of the databases.
- Section 5.1: addition of a second bullet to cover additional functionality and removal of half of Editor’s note in Section 7.1.
- Section 5.2: addition of IPSec related functionality and database to cover Ze interface security.
- Section 5.4: Clarification of the setting of the SPI by the destination PLMN’s KAC.
- Section 5.5.1: Correction in SPI parameter definition.
- Section 7: Moved remainder of Editor’s note forward.
- Annex A: Added Editor’s note about message flows needing upgrading to account for automatic key management.

The above changes are implemented in 33_200_5_0_1_1 attached. A version (33_200_5_0_1_1_changebars) with changes bars from TS 33.200 Rel-4 v4.1.0 is also attached.

Nothing has been done to Sections 7 and 8, as these require large changes to be agreed at the meeting.

The following are a list of areas of uncertainty:

- Is a more detailed discussion of the KAC-SPDB-MAP needed?
- If so, in section 5.3 or a new section?
- Should Annex A be left, even if blank, to keep section numbering consistent over Releases.

3GPP TS 33.200 V04.1.10 (2001-1109)

Technical Specification

**3rd Generation Partnership Project;
Technical Specification Group Services and System Aspects;
3G Security;
Network Domain Security;
MAP application layer security
(Release 54)**



The present document has been developed within the 3rd Generation Partnership Project (3GPP™) and may be further elaborated for the purposes of 3GPP.

The present document has not been subject to any approval process by the 3GPP Organizational Partners and shall not be implemented. This Specification is provided for future development work within 3GPP only. The Organizational Partners accept no liability for any use of this Specification. Specifications and reports for implementation of the 3GPP™ system should be obtained via the 3GPP Organizational Partners' Publications Offices.

Keywords

Security, Core Network, MAP, Key management

3GPP

Postal address

3GPP support office address

650 Route des Lucioles - Sophia Antipolis
Valbonne - FRANCE
Tel.: +33 4 92 94 42 00 Fax: +33 4 93 65 47 16

Internet

<http://www.3gpp.org>

Copyright Notification

No part may be reproduced except as authorized by written permission.
The copyright and the foregoing restriction extend to reproduction in all media.

© 2001, 3GPP Organizational Partners (ARIB, CWTS, ETSI, T1, TTA, TTC).
All rights reserved.

Contents

Foreword.....	5
Introduction.....	5
1 Scope.....	6
2 References.....	6
3 Definitions, symbols and abbreviations.....	6
3.1 Definitions.....	6
3.2 Symbols.....	7
3.3 Abbreviations.....	7
3.4 Conventions.....	8
4 Principles of MAP application layer security.....	8
5 MAP security (MAPsec).....	9
5.1 Key Administration Centres (KACs).....	9
5.2 Properties and tasks of MAPsec enabled network elements.....	10
5.3 Policy requirements for the MAPsec Security Policy Database (SPD).....	11
5.4 MAPsec security association attribute definition.....	11
5.5 MAPsec structure of protected messages.....	12
5.5.1 MAPsec security header.....	12
5.5.2 Protected payload.....	13
5.5.2.1 Protection Mode 0.....	13
5.5.2.2 Protection Mode 1.....	13
5.5.2.3 Protection Mode 2.....	13
5.6 MAPsec algorithms.....	14
5.6.1 Mapping of MAP-SA encryption algorithm identifiers.....	14
5.6.1.1 Description of MEA-1.....	14
5.6.2 Mapping of MAP-SA integrity algorithm identifiers.....	14
5.6.2.1 Description of MIA-1.....	14
5.6.3 Construction of IV.....	14
6 MAPsec protection profiles.....	15
6.1 Granularity of protection.....	15
6.2 MAPsec protection groups.....	15
6.2.1 MAPsec protection groups.....	15
6.2.1.1 MAP-PG(0) – No Protection.....	15
6.2.1.2 MAP-PG(1) – Protection for Reset.....	15
6.2.1.3 MAP-PG(2) – Protection for Authentication Information except Handover Situations.....	16
6.2.1.4 MAP-PG(3) – Protection for Authentication Information in Handover Situations.....	16
6.2.1.5 MAP-PG(4) – Protection of non location dependant HLR data.....	16
6.3 MAPsec protection profiles.....	17
7 Inter-domain Security Association and Key Management Procedures.....	17
7.1 MAPsec required modifications to standard IKE.....	17
8 Local Security Association Distribution.....	18
8.1 SA lifetime supervision at KAC and NEs.....	18
8.2 Request SA Procedure.....	18

Annex A (normative): MAPsec message flows	21
Annex B (informative): Change history	24
Foreword	4
Introduction	4
1— Scope	5
2— References	5
3— Definitions, symbols and abbreviations	5
3.1— Definitions	5
3.2— Symbols	6
3.3— Abbreviations	6
3.4— Conventions	6
4— Principles of MAP application layer security	7
5— MAP security (MAPsec)	7
5.1— Security services provided by MAPsec	7
5.2— Properties and tasks of MAPsec-enabled network elements	7
5.3— Policy requirements for the MAPsec Security Policy Database (SPD)	8
5.4— MAPsec security association attribute definition	8
5.5— MAPsec structure of protected messages	9
5.5.1— MAPsec security header	9
5.5.2— Protected payload	10
5.5.2.1— Protection Mode 0	10
5.5.2.2— Protection Mode 1	10
5.5.2.3— Protection Mode 2	10
5.6— MAPsec algorithms	11
5.6.1— Mapping of MAP-SA encryption algorithm identifiers	11
5.6.1.1— Description of MEA-1	11
5.6.2— Mapping of MAP-SA integrity algorithm identifiers	11
5.6.2.1— Description of MIA-1	11
5.6.3— Construction of IV	11
6— MAPsec protection profiles	12
6.1— Granularity of protection	12
6.2— MAPsec protection groups	12
6.2.1— MAPsec protection groups	12
6.2.1.1— MAP-PG(0)— No Protection	12
6.2.1.2— MAP-PG(1)— Protection for Reset	12
6.2.1.3— MAP-PG(2)— Protection for Authentication Information except Handover Situations	13
6.2.1.4— MAP-PG(3)— Protection for Authentication Information in Handover Situations	13
6.2.1.5— MAP-PG(4)— Protection of non-location dependant HLR data	13
6.3— MAPsec protection profiles	14
Annex A (informative): Guidelines for manual key management	15
A.1— Inter-domain Security Association and Key Management Procedures	15
A.2— Local Security Association Distribution	15
Annex B (normative): MAPsec message flows	16
Annex C (informative): Change history	19

Foreword

This Technical Specification has been produced by the 3rd Generation Partnership Project (3GPP).

The contents of the present document are subject to continuing work within the TSG and may change following formal TSG approval. Should the TSG modify the contents of the present document, it will be re-released by the TSG with an identifying change of release date and an increase in version number as follows:

Version x.y.z

where:

- x the first digit:
 - 1 presented to TSG for information;
 - 2 presented to TSG for approval;
 - 3 or greater indicates TSG approved document under change control.
- y the second digit is incremented for all changes of substance, i.e. technical enhancements, corrections, updates, etc.
- z the third digit is incremented when editorial only changes have been incorporated in the document.

Introduction

The absence of security in Signalling System No. 7 (SS7) networks is an identified security weakness in 2G systems. This was formerly perceived not to be a problem, since the SS7 networks were the provinces of a small number of large institutions. This is no longer the case, and so there is now a need for security precautions.

For 3G systems it is a clear goal to be able to protect the core network signalling protocols, and by implication this means that security solutions must be found for both SS7 and IP based protocols.

Various protocols and interfaces are used for control plane signalling within and between core networks. The security services that have been identified as necessary are confidentiality, integrity, authentication and anti-replay protection. These will be ensured by standard procedures, based on cryptographic techniques.

1 Scope

This technical specification covers the security mechanisms and procedures necessary to protect the MAP protocol. The complete set of enhancements and extensions to facilitate security protection for the MAP protocol is termed MAPsec and it covers transport security in the MAP protocol itself and the security management procedures.

The security mechanisms specified for MAP are on the application layer. This means that MAPsec is independent of the network and transport protocols to be used. [This specification also includes automatic key management mechanisms to update the security associations used to protect the MAP signalling.](#)

This technical specification contains the stage-2 specification for security protection of the MAP protocol. The actual implementation (stage-3) specification can be found in the MAP stage-3 specification, TS 29.002 [4].

~~NOTE:— It is explicitly noted that automated key management and key distribution is not part of Rel-4. All key management and key distribution in Rel-4 must therefore be carried out by other means. (See Annex A)~~

2 References

The following documents contain provisions which, through reference in this text, constitute provisions of the present document.

- References are either specific (identified by date of publication, edition number, version number, etc.) or non-specific.
- For a specific reference, subsequent revisions do not apply.
- For a non-specific reference, the latest version applies. In the case of a reference to a 3GPP document (including a GSM document), a non-specific reference implicitly refers to the latest version of that document *in the same Release as the present document*.

- [1] 3G TS 21.133: Security Threats and Requirements.
- [2] 3G TS 21.905: 3G Vocabulary.
- [3] 3G TS 23.060: General Packet Radio Service (GPRS); Service description; Stage 2.
- [4] 3G TS 29.002: Mobile Application Part (MAP) specification.
- [5] ISO/IEC 10116: "Information technology -- Security techniques -- Modes of operation for an n-bit block cipher", Ed.2, 1997-04-17.
- [6] ISO/IEC 9797: "Information technology -- Security techniques -- Message Authentication Codes (MACs) -- Part 1: Mechanisms using a block cipher", Ed.1, 1999-12-16.
- [7] [draft-arkko-map-doi-04-pa2.txt: The MAP Security Domain of Interpretation for ISAKMP](#)

3 Definitions, symbols and abbreviations

3.1 Definitions

For the purposes of the present document, the following terms and definitions apply.

Anti-replay protection: Anti-replay protection is a special case of integrity protection. Its main service is to protect against replay of self-contained packets that already have a cryptographic integrity mechanism in place.

Confidentiality: The property that information is not made available or disclosed to unauthorised individuals, entities or processes.

Data integrity: The property that data has not been altered in an unauthorised manner.

Data origin authentication: The corroboration that the source of data received is as claimed.

Entity authentication: The provision of assurance of the claimed identity of an entity.

Key freshness: A key is fresh if it can be guaranteed to be new, as opposed to an old key being reused through actions of either an adversary or authorised party.

Security Association: A logical connection created for security purposes. All traffic traversing a security association is provided the same security protection. The security association specifies protection levels, algorithms to be used, lifetime of the connection etc.

MAPsec: The complete collection of protocols and procedures needed to protect MAP messages. MAPsec can be divided into three main parts. These are (1) MAPsec transport security, (2) MAPsec Local Security Association distribution and (3) MAPsec Inter-domain Security Association and Key Management procedures.

3.2 Symbols

For the purposes of the present document, the following symbols apply:

f6	MAP encryption algorithm
f7	MAP integrity algorithm
Zd	MAPsec interface between KACs belonging to different PLMNs
Ze	MAPsec interface between KACs and MAP-NEs within the same PLMN
Zf	The MAP application layer security interface between MAP-NEs engaged in security protected signalling.

3.3 Abbreviations

For the purposes of the present document, the following abbreviations apply:

AES	Advanced Encryption Standard
DoI	Domain of Interpretation
ESP	Encapsulating Security Payload
FALLBACK	Fallback to unprotected mode indicator
IETF	Internet Engineering Task Force
IKE	Internet Key Exchange
IP	Internet Protocol
IPsec	IP security - a collection of protocols and algorithms for IP security incl. key mngt.
ISAKMP	Internet Security Association Key Management Protocols
IV	Initialisation Vector
KAC	Key Administration Centre
MEK	MAP Encryption Key
MAC	Message Authentication Code
MAC-M	MAC used for MAP
MAP	Mobile Application Part
MAP-NE	MAP Network Element
MAPsec	MAP security – the MAP security protocol suite
MEA	MAP Encryption Algorithm identifier
MEK	MAP Encryption Key
MIA	MAP Integrity Algorithm identifier
MIK	MAP Integrity Key
NDS	Network Domain Security
NE	Network Entity
PPI	Protection Profile Indicator
PROP	Proprietary field
SA	Security Association

SADB	Security Association DataBase
SPD	Security Policy Database (sometimes also referred to as SPDB)
SPI	Security Parameters Index
TVP	Time Variant Parameter

3.4 Conventions

All data variables in this specification are presented with the most significant substring on the left hand side and the least significant substring on the right hand side. A substring may be a bit, byte or other arbitrary length bitstring. Where a variable is broken down into a number of substrings, the leftmost (most significant) substring is numbered 0, the next most significant is numbered 1, and so on through to the least significant.

4 Principles of MAP application layer security

This technical specification defines mechanisms for protecting the MAP protocol at the application layer. The MAP protocol may also be protected at the network layer when IP is used as the transport protocol. However, whenever interworking with networks using SS7-based transport is necessary, protection at the application layer shall be used.

The security measures specified in this TS are only fully useful if all interconnected operators use them. In order to prevent active attacks all interconnected operators must at least use MAPsec with the suitable protection levels as indicated in this specification and treat the reception of all MAP messages (protected and unprotected) in a uniform way in the receiving direction.

Before protection can be applied, Security Associations (SA) needs to be established between the respective MAP network elements. Security associations define, among other things, which keys, algorithms, and protection profiles to use to protect MAP signalling. The necessary MAP-SAs between networks are negotiated between the respective [Key Administration Centres \(KACs\) of the networks/network operators](#). The negotiated SA will be effective PLMN-wide and distributed to all network elements, which implement MAP application layer security within the PLMN. Signalling traffic protected at the application layer will, for routing purposes, be indistinguishable from unprotected traffic to all parties except for the sending and receiving entities.

[Figure 1](#) gives an overview of the architecture used for MAPsec.

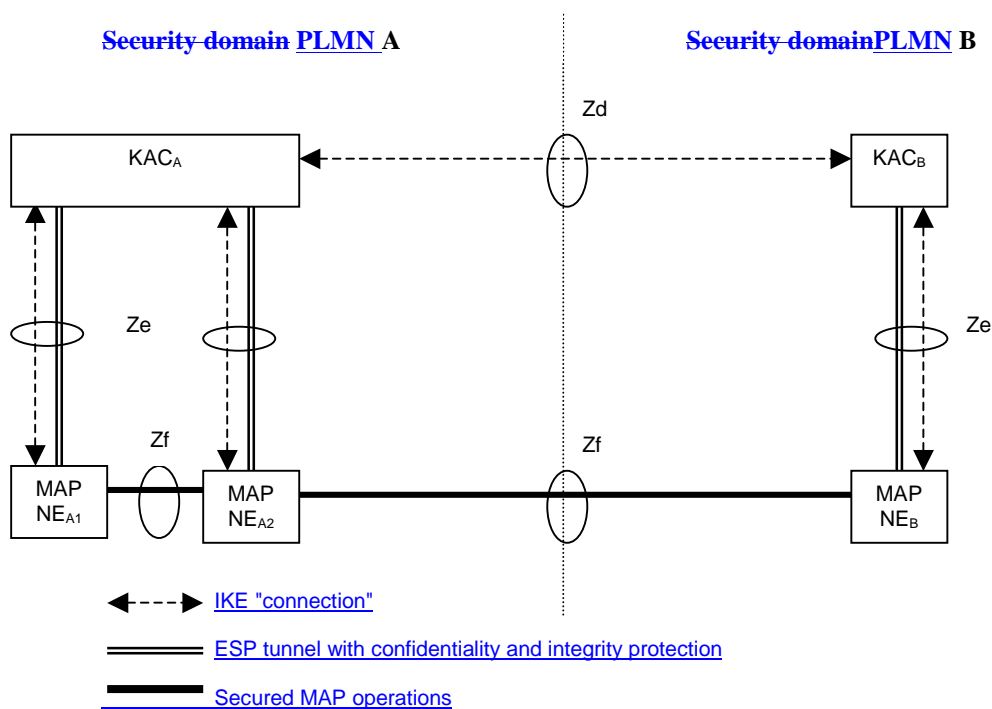

Figure 1: Overview of the Z_d, Z_e and Z_f interfaces

The following interfaces are defined MAPsec.

- Zd-interface (KAC-KAC)

The Zd-interface is used to negotiate MAPsec Security Associations (SAs) between PLMNs. The traffic over Zd consists only of IKE negotiations. The negotiated MAPsec SAs are valid on a PLMN to PLMN basis.

- Ze-interface (KAC-NE)

The Ze-interface is located between MAP-NEs and a KAC from the same PLMN. This interface is used for transport of MAPsec SAs and the relevant security policy information from the KAC to the MAP-NE. The KAC and the MAP-NE are able to establish and maintain an ESP tunnel between them. Whether the tunnel is established when needed or a priori is for the PLMN operator to decide.

- The Zf-interface (NE-NE)

The Zf-interface is located between MAP-NEs. The MAP-NEs may be from the same PLMN or from different PLMNs (as shown in figure 1). The MAP-NEs use MAPsec SAs received from a KAC to protect the MAP operations. The MAP operations within the MAP dialogue are protected selectively as specified in the applied MAPsec protection profile. The interface applies to all MAPsec transactions, intra- or inter-PLMN.

Protection at the application layer implies changes to the application protocol itself to allow for the necessary security functionality to be added.

The MAP application layer security interface between MAP-NEs engaged in security protected signalling is referred to in this specification as the Zf interface. The interface applies to all MAPsec transactions, intra- or inter-PLMN.

The security services provided by MAPsec are:

- data integrity;
- data origin authentication;
- anti-replay protection;
- confidentiality (optional).

Annex [AB](#) includes detailed procedures on how secure MAP signalling is performed between two MAP-NEs.

5 MAP security (MAPsec)

5.1 Security services provided by MAPsec Properties and tasks of Key Administration Centres (KACs)

The security services provided by MAPsec are:

- data integrity;
- data origin authentication;
- anti-replay protection;
- confidentiality (optional).

Key Administration Centres (KACs) are entities that are used for negotiating MAPsec SAs on behalf of MAP-NEs. The KACs are defined to handle communication over these interfaces:

- the Zd-interface, which is located between KACs from different PLMNs. The IKE protocol with support for MAPsec DoI shall be used over this interface.

- the Ze-interface, which is located between a KAC and a MAP-NE within the same PLMN is used to transfer MAPsec SAs and security policy from KACs to MAP-NEs. The IKE and ESP protocols may be used to negotiate and secure the connection between the KAC and the MAP-NE.

When MAP-NEs need to establish a secure connection towards another MAP-NEs they will request a MAPsec SA from the KAC. The KAC will then either provide an existing MAPsec SAs or negotiate a new MAPsec SA, before returning the MAPsec SA to the MAP-NE.

A MAPsec SA is valid for all MAP communication between the two PLMNs for which it is negotiated. That is, the same MAPsec SA shall be provided to all MAP-NE in PLMN A when communicating with MAP-NEs in PLMN B. Each PLMN can have one or more KACs. Each KAC will be defined to negotiate MAPsec SAs with a well-defined set of reachable PLMNs. The number of KACs in a PLMN will depend on the need to differentiate between the externally reachable destinations, the need to balance the traffic load and to avoid single point of failures.

KACs perform the following operations:

- Negotiate SAs for MAPsec with other KACs belonging to other network operators. This action is triggered either by request for a MAP-SA by a NE or by policy enforcement when MAP-SAs always should be available. MAP-SAs negotiation is performed at Zd-interface using IKE protocol with MAPsec DoI.
- Convert specific negotiated SA parameter so that they can be understood by NEs. In particular, the KAC shall convert negotiated SA duration in seconds as negotiated in MAPsec DoI to UTC absolute time format.
- Perform refresh of MAP-SAs. Triggered internally by SA lifetime supervision, which is depends on the policies set by the operator.
- Distribute MAP-SA and policy information to NEs belonging to the same PLMN as the KAC.
- (Optional) KAC may be able to establish IPSec connections supporting IKE with IPSec DOI in order to secure transmission of MAP-SAs to the NEs within its PLMN.

KACs are also responsible for the maintenance of the following databases:

- KAC-SPDB-MAP: Defines the scope, the security policy, in which MAP-SAs may be negotiated (e.g. allowed MAP-PPs, Algorithms, SA-lifetimes). This database is updated on operator initiative in the framework of the roaming agreements.
- NE-SPD-MAP: A database in a KAC containing the MAP security policy information that will be used by an NE in protecting MAP messages (e.g. value of "Fallback to unprotected Mode Indicator" and table of protected MAPsec operation components). This is held to update the NEs.
- NE-SADB-MAP: A database in a KAC containing MAP-SA information. This is held to allow the KAC to update the NE.
- (Optional) KAC-SPDB-IP: Defines the scope, the security policy, in which IPSec-SAs may be negotiated at the Ze-interface.
- (Optional) KAC-SADB-IP: Containing IPSec-SAs for protection of IP traffic between the KAC and NEs over the Ze-interface.

KACs are responsible for security sensitive operations and shall be physically secured. They shall offer capabilities for the secure storage of long-term keys used for IKE authentication.

5.2 Properties and tasks of MAPsec enabled network elements

MAPsec MAP-NEs shall maintain the following databases:

- NE-SPD-MAP: A database in an NE containing MAP security policy information (see clause 5.3);
- NE-SADB-MAP: A database in an NE containing MAP-SA information. MAP-NEs shall monitor the SA lifetime and expired SAs shall be deleted from the database (see clause 5.4).
- (Optional) NE-SPDB-IP: Defines the scope, the security policy, in which IPSec-SAs may be negotiated at the Ze-interface.

- [\(Optional\) NE-SADB-IP: Containing IPSec-SAs for protection of IP traffic between the KAC and NEs over the Ze-interface.](#)

MAPsec MAP-NEs shall be able to perform the following operations:

- [Secure MAP signalling \(i.e. send/receive protected or unprotected messages\) according to information in NE-SPD-MAP and NE-SADB-MAP. The structure of protected messages is defined in clause 5.5 and the protection algorithms are defined in clause 5.6.](#)
- [Communicate with the KAC in the same PLMN in order that the NE-SPD-MAP and NE-SADB-MAP in the NE can be updated.](#)
- [\(Optional\) NE may be able to establish IPSec connections supporting IKE with IPSec DOI in order to secure transmission of MAP-SAs to the KAC within its PLMN.](#)

5.3 Policy requirements for the MAPsec Security Policy Database (SPD)

The security policies for MAPsec key management are specified in the NE's SPD. SPD entries define which MAP operation components are protected and which MAP SAs (if any) to use to protect MAP signalling based on the PLMN of the peer NE. There can be no local security policy definitions for individual NEs. Instead, SPD entries of different NE within the same PLMN shall be identical.

Fallback to unprotected mode:

- The "fallback to unprotected mode" (enabled/disabled) shall be available to the MAP-NE before any communication towards other MAP-NEs can take place. For the receiving direction, it is sufficient to have a single parameter indicating whether fallback for incoming messages is allowed or not. For the sending direction, the information should indicate for each destination PLMN whether fallback for outgoing messages is allowed or not;
- The use of the fallback indicators is specified in Annex [AB](#);
- The security measures specified in this TS are only fully useful for a particular PLMN if it disallows fallback to unprotected mode for MAP messages received from any other PLMN.

Table of MAPsec operation components:

- The security policy database (SPD) shall contain a table of MAPsec operation components for incoming messages. This table contains operation components which have to be carried in MAPsec messages with Protection Mode 1 or 2. The use of MAPsec operation components is specified in Annex [AB](#).

Uniformity of protection profiles:

- In order to ensure full protection, a particular PLMN shall use the same protection profile for incoming MAPsec messages from all other PLMNs. In particular, full protection is not ensured when protection profile A (no protection) is used for some source PLMNs and other profiles are used for other source PLMNs.

Editor's note: Some issues need to be investigated: Non-synchronised expiration times issue, mechanism to distinguish inbound/outbound SPDs ?

5.4 MAPsec security association attribute definition

The MAPsec security association shall contain the following data elements:

- MAP Encryption Algorithm identifier (MEA):

Identifies the encryption algorithm. Mode of operation of algorithm is implicitly defined by the algorithm identifier. Mapping of algorithm identifiers is defined in clause 5.6.

- MAP Encryption Key (MEK):

Contains the encryption key. Length is defined according to the algorithm identifier.

- MAP Integrity Algorithm identifier (MIA):

Identifies the integrity algorithm. Mode of operation of algorithm is implicitly defined by the algorithm identifier. Mapping of algorithm identifiers is defined in section 5.6.

- MAP Integrity Key (MIK):

Contains the integrity key. Length is defined according to the algorithm identifier.

- Protection Profile Identifier (PPI):

Identifies the protection profile. Length is 16 bits. Mapping of profile identifiers is defined in section 6.

- SA Lifetime:

Defines the actual expiry time of the SA. The expiry of the lifetime shall be given in UTC time.

Editor's Note: The exact format and length to be defined.

A MAPsec SA is uniquely identified by a destination PLMN-Id and a Security Parameters Index, SPI. As a consequence, during SA creation, the SPI is always chosen by the receiving side ([i.e. the SPI for MAP communications from PLMN A to PLMN B is selected by KAC in PLMN B](#)).

If the SA is to indicate that MAPsec is not to be applied then all the algorithm attributes shall contain a NULL value.

5.5 MAPsec structure of protected messages

MAPsec provides for three different protection modes and these are defined as follows:

Protection Mode 0: No Protection

Protection Mode 1: Integrity, Authenticity

Protection Mode 2: Confidentiality, Integrity, and Authenticity

MAP operations protected by means of MAPsec consist of a Security Header and the Protected Payload. Secured MAP messages have the following structure:

Security Header	Protected Payload
-----------------	-------------------

In all three protection modes, the security header is transmitted in cleartext.

In protection mode 2 providing confidentiality, the protected payload is essentially the encrypted payload of the original MAP message. For integrity and authenticity in protection mode 1, the message authentication code is calculated on the security header and the payload of the original MAP message in cleartext and it is included in the protected payload. The message authentication code in protection mode 2 is calculated on the security header and the encrypted payload of the original MAP message. In protection mode 0 no protection is offered, therefore the protected payload is identical to the payload of the original MAP message.

5.5.1 MAPsec security header

The security header is a sequence of the following data elements:

Security header = TVP // NE-Id // Prop // Sending PLMN-Id // SPI // Original component Id

- TVP:

The TVP is used for replay protection of Secured MAP operations is a 32 bit time-stamp. The receiving network entity will accept an operation only if the time-stamp is within a certain time-window. The resolution of the clock from which the time-stamp is derived is 0.1 seconds. The size of the time-window at the receiving network entity is not standardised.

- NE-Id:

6 octets used to create different IV values for different NEs within the same TVP period. It is necessary and sufficient that *NE-Id* is unique per PLMN. (This is sufficient because sending keys are unique per PLMN.) The NE-Id shall be the E.164 global title of the NE without the MCC and MNC.

- Proprietary field (PROP):

4 octets used to create different IV values for different protected MAP messages within the same TVP period for one NE. The usage of the proprietary field is not standardised.

- Sending PLMN-Id:

PLMN-Id is the ID number of the sending Public Land Mobile Network (PLMN). The value for the PLMN-Id is a concatenation of the Mobile Country Code (MCC) and Mobile Network Code (MNC) of the sending network.

- Security Parameters Index (SPI):

SPI is an arbitrary 32-bit value that is used in combination with the [destination sender's](#) PLMN-Id to uniquely identify a MAP-SA.

- Original Component identifier:

Identifies the type of component (invoke, result or error) within the MAP operation that is being securely transported (Operation identified by operation code, Error defined by Error Code or User Information).

5.5.2 Protected payload

5.5.2.1 Protection Mode 0

Protection Mode 0 offers no protection at all. Therefore, the protected payload of Secured MAP messages in protection mode 0 is identical to the original MAP message payload in cleartext.

5.5.2.2 Protection Mode 1

The protected payload of Secured MAP messages in protection mode 1 takes the following form:

Cleartext f7(Security Header Cleartext)

where "Cleartext" is the payload of the original MAP message in cleartext. Therefore, in Protection Mode 1 the protected payload is a concatenation of the following information elements:

- Cleartext
- Message authentication code (MAC-M) calculated by the function f7

Authentication of origin and message integrity are achieved by applying the message authentication code (MAC-M) function f7 with the integrity key defined by the security association to the concatenation of Security Header and Cleartext. The MAC-M length shall be 32 bits.

5.5.2.3 Protection Mode 2

The protected payload of Secured MAP Messages in protection mode 2 takes the following form:

f6(Cleartext) f7(Security Header f6(Cleartext))

where "Cleartext" is the original MAP message payload in cleartext. Confidentiality is achieved by encrypting Cleartext using the encryption function f6 with the confidentiality key defined by the security association and the initialisation vector (IV). Authentication of origin and integrity are achieved by applying the message authentication code (MAC-M) function f7 with the integrity key defined by the security association to the concatenation of Security Header and ciphertext. The MAC-M length shall be 32 bits. The length of the ciphertext is the same as the length of the cleartext.

5.6 MAPsec algorithms

5.6.1 Mapping of MAP-SA encryption algorithm identifiers

The MEA algorithm indication fields in the MAP-SA are used to identify the encryption algorithm and algorithm mode to be used. The mapping of algorithm identifiers is defined below.

Table 1: MAP encryption algorithm identifiers

MAP Encryption Algorithm identifier	Description
0	Null
1	AES in a stream cipher mode (MANDATORY)
:	-not yet assigned-
15	-not yet assigned-

5.6.1.1 Description of MEA-1

The MEA-1 algorithm is the ISO/IEC 10116 Counter Mode with parameter $j=128$ bits, $SV=IV$ and truncation of the last block is according to the method described in ISO/IEC 10116 Annex A.5.3. See ISO/IEC 10116 [5] for more information.

Editor's Note: More specification on the mode of operation for MEA-1 may be required.

5.6.2 Mapping of MAP-SA integrity algorithm identifiers

The MIA algorithm indication fields in the MAP-SA are used to identify the integrity algorithm and algorithm mode to be used. The mapping of algorithm identifiers is defined below.

Table 2: MAP integrity algorithm identifiers

MAP Integrity Algorithm identifier	Description
0	Null
1	AES in a CBC MAC mode with a 128-bit key (MANDATORY)
:	-not yet assigned-
15	-not yet assigned-

5.6.2.1 Description of MIA-1

The MIA-1 algorithm is the ISO/IEC 9797 Part 1: padding method 2, MAC algorithm 1 (initial transformation=1, output transformation=1). No IV used. The MAC-length m is 32-bits (see clause 5.6.1). See ISO/IEC 9797 [6] for more information.

5.6.3 Construction of IV

The IV used in the encryption shall be constructed as follows:

$$IV = TVP \parallel NE-Id \parallel Prop \parallel Pad$$

The padding field is used to expand $TVP \parallel NE-Id \parallel Prop$ to the IV length required by the cryptographic scheme in use.

The IV length shall be 16 octets. The padding (Pad) shall be 2 octets with all bits set to zero.

6 MAPsec protection profiles

6.1 Granularity of protection

MAPsec protection is specified per MAP operation component.

6.2 MAPsec protection groups

This section specifies groups of messages and their protection modes at the operation component level. Individual protection groups or particular combinations of groups can then be used to construct protection profiles as specified in section 6.3.

Combinations of overlapping protection groups are forbidden. Forbidden combinations are explicitly specified in 6.2.1 below.

The concept of "protection levels" is introduced to administrate the protection mode on operation component level. A protection level of an operation determines the protection modes used for the operation's components according to the following table.

Table 3: MAPsec protection levels

Protection level	Protection mode for <i>invoke</i> component	Protection mode for <i>result</i> component	Protection mode for <i>error</i> component
1	1	0	0
2	1	1	0
3	1	2	0
4	2	1	0
5	2	2	0
6	2	0	0

6.2.1 MAPsec protection groups

6.2.1.1 MAP-PG(0) – No Protection

This MAP-PP does not contain any operation and it does not protect any information. It is useful however to have a "null" MAP-PP to use in situations where no security is required or is an option. This protection group cannot be combined with any other protection group.

6.2.1.2 MAP-PG(1) – Protection for Reset

Table 4: PG(1) – Protection for Reset

Application Context/Operation	Protection Level
ResetContext-v2/ Reset	1
ResetContext-v1/ Reset	1

6.2.1.3 MAP-PG(2) – Protection for Authentication Information except Handover Situations

Table 5: PG(2) – Protection for Authentication Information except Handover Situations

Application Context/Operation	Protection Level
InfoRetrievalContext-v3/ Send Authentication Info	3
InfoRetrievalContext-v2/ Send Authentication Info	3
InfoRetrievalContext-v1/ Send Parameters	3
InterVlrInfoRetrievalContext-v3/ Send Identification	3
InterVlrInfoRetrievalContext-v2/ Send Identification	3

6.2.1.4 MAP-PG(3) – Protection for Authentication Information in Handover Situations

Table 6: PG(3) – Protection for Authentication Information in Handover Situations

Application Context/Operation	Protection Level (Component level)
HandoverControlContext-v3/ Prepare Handover (Note that the AC contains also other operations)	4
HandoverControlContext-v3/ Forward Access Signalling (Note that the AC contains also other operations)	4
HandoverControlContext-v2/ Prepare Handover (Note that the AC contains also other operations)	4
HandoverControlContext-v2/ Forward Access Signalling (Note that the AC contains also other operations)	4
HandoverControlContext-v1/ Perform Handover (Note that the AC contains also other operations)	4
HandoverControlContext-v1/ Forward Access Signalling (Note that the AC contains also other operations)	4

6.2.1.5 MAP-PG(4) – Protection of non location dependant HLR data

Table 7: PG(4) – Protection of non location dependant HLR data

Application Context/Operation	Protection Level
AnyTimInfoHandlingContext-v3 / AnyTimeModification	1
SubscriberDataMngtContext-v3 / DeleteSubscriberData	1

Editor's Note: Protection Group 4 is not complete.

6.3 MAPsec protection profiles

Protection profiles can be individual protection groups or particular combinations of protection groups. MAP protection profiles are coded as a 16 bit binary number where each bit corresponds to a protection group. Currently only 5 groups are defined, the rest are reserved for future use.

Table 8: Protection profile encoding

Protection profile bit	Protection group
0	No protection
1	Reset
2	Authentication information except handover situations
3	Authentication information in handover situations
4	Non-location dependant HLR data
5-15	Reserved

Protection profiles shall be bidirectional.

The following protection profiles are defined.

Table 9: Protection profile definition

Protection profile name	Protection group				
	PG(0) <i>No protection</i>	PG(1) <i>Reset</i>	PG(2) <i>AuthInfo except handover situations</i>	PG(3) <i>AuthInfo in handover situation</i>	PG(4) <i>Non-location dependant HLR data</i>
Profile A	✓				
Profile B		✓	✓		
Profile C		✓	✓	✓	
Profile D		✓	✓	✓	✓
Profile E		✓	✓		✓

7 Inter-domain Security Association and Key Management Procedures

The overall architecture is defined in clause 5. This section only contains additional material to define the Zd-interface and the IKE protocol when used with the MAPsec DoI ([7]). Clause 7 contains material that complements the MAPsec DoI.

Editor's Note: Soft Expiry Time is not negotiated between KACS.

7.1 MAPsec required modifications to standard IKE

For MAPsec KAC←→KAC negotiation standard IKE Phase 1 shall be used. It is also required that only Main Mode shall be used for MAPsec.

A new Phase 2 mode - the MAP mode, must be introduced. The MAP mode differs from the existing IKE quick mode in the following respects:

- Payloads included to the messages of MAP mode are the same as in Quick Mode but the contents of the payloads differ in the case SA payload and ID payloads.

- Either the identity is never sent or if sent it will be the PLMID in f_qdn or der_qn encoded form (or the key_id).

KEYMAT for MAPsec SA template (as in the present Quick mode).

8 Local Security Association Distribution

8.1 SA lifetime supervision at KAC and NEs

In order to improve processing time of the first message in a secure communication, the KACs and/or NEs might introduce the option to always maintain SAs alive.

With this option, KACs shall control the SA lifetime and negotiate a new SA before the SA in use expires in order to maintain continuously valid SAs for all or some pre-configured network domains. When a NE requests a SA, the KAC must answer with the recent one.

In a similar way and as a configuration option, NEs might supervise the SA lifetime and request a new one before the SA in use expires.

The following considerations must be noticed:

- All nodes might try to update their SAs at the same time, so in order to prevent KAC overload, SA requests from the NEs should be randomised.
- Two SAs can be valid during the same period of time; i.e. KAC might have negotiated a fresh SA before older one has expired.

8.2 Request SA Procedure

For local security association distribution a pure pull approach has been selected. The mechanism is outlined in more detail in Figure-3.

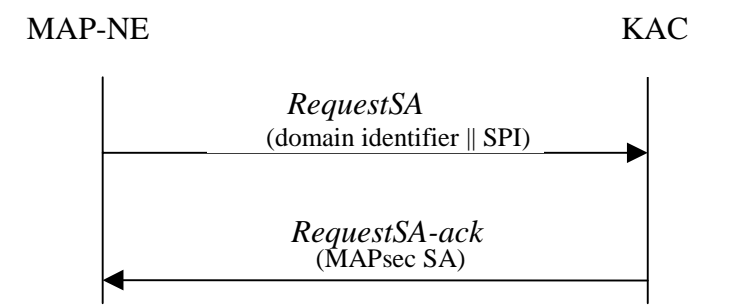

Figure 3: RequestSA procedure

The purpose of this procedure is to provide a MAP-NE with valid MAP-SA information to establish secure MAP communication with another MAP-NE.

The procedure is invoked by a MAP-NE when MAP communication towards another MAP-NE is to be initiated and no valid SA information is available at the MAP-NE SADB. Optionally, the procedure may also be initiated when the MAP-NE is configured to always maintain valid SAs.

The MAP-NE sends a *request SA* to the KAC; this message contains the domain identifier of the PLMN the MAP-NE wishes to communicate with (i.e. destination PLMNid). In the event, the MAP-NE initiated the procedure with the purpose to refresh an existing SA (just expired or about to), the SPI (pair) of the SA being replaced shall be also included.

The answer from the KAC may include one of the following responses:

- Valid SA information to secure MAP communication to and from the PLMN identified in the request.
- An indication that MAP communication towards/from that specific PLMN does not need to be secured at that moment. This indication has a limited lifetime (also included in the response) to allow future changes in policy.
- An error response informing that the KAC is not able to provide the MAP-NE with valid SA information at that moment.

In order to perform this procedure in a secure manner, the KAC and MAP-NE might be able to use IKE to negotiate, establish and maintain an ESP tunnel between them. Whether the tunnel is established is for the PLMN operator to decide.

This procedure does not allow notification from KAC to MAP-NEs. If SAs are compromised, additional measures shall be applied in order to abort new or secure communication in progress (e.g. MAP Policy).

~~Annex A (informative):
Guidelines for manual key management~~

~~A.1 — Inter-domain Security Association and Key Management Procedures~~

~~Manual Inter-domain Security Association and Key Management procedures is subject to roaming agreements.~~

~~Some important parts of an inter-domain Security Association and Key Management agreement is:~~

- ~~— to define how to carry out the initial exchange of MAPsec SAs;~~
- ~~— to define how to renew the MAPsec SAs;~~
- ~~— to define how to withdraw MAPsec SAs (including requirements on how fast to execute the withdrawal);~~
- ~~— to decide if fallback to unprotected mode is to be allowed;~~
- ~~— to decide on key lengths, algorithms, protection profiles, and SA lifetime etc (MAPsec SAs are expected to be fairly long lived).~~

~~When renewing a MAPsec SA used for incoming MAP traffic, the "old" SA should be kept in the NEs until its expiry time is reached, unless the SA renewal was due to compromise of the keys of the "old" SA, in which case the "old" compromised SA should immediately be removed from the SAD.~~

~~When renewing a MAPsec SA used for outgoing MAP traffic, the "old" SA should continue to be used by the NEs until its expiry time is reached, unless the SA renewal was due to compromise of the keys of the "old" SA in which case the "old" compromised SA should immediately be removed from the SAD. Note that one way to force the NEs to use a newly defined MAPsec SA is to distribute to NEs a new version of the SAD in which the old SA no longer exists but only the new SA.~~

~~To ease SA renewal, both PLMNs may decide to set up several MAPsec SAs in advance so that NEs can automatically switch from one SA to another SA when the former expires. In such a situation, the MAPsec SAs would have different expiry times.~~

~~A.2 — Local Security Association Distribution~~

~~Manual Local Security Association Distribution is executed entirely within one PLMN and is consequently at the discretion of the administrative authority.~~

~~The requirement on the manual distribution procedures can be summarized as follows:~~

- ~~— Procedures for transporting the relevant MAPsec SA to the MAP-NEs must be defined. In order to ensure that the MAPsec SA are present when needed, all valid MAPsec SA should be distributed to all MAP-NEs as soon as they are available.~~
- ~~— Procedures for revocation of MAPsec SAs must be defined~~

Annex **AB** (normative): MAPsec message flows

Imagine a network scenario with two MAP-NEs at different PLMNs (NEa and NEb) willing to communicate using MAPsec. Figure 1 presents the message flow.

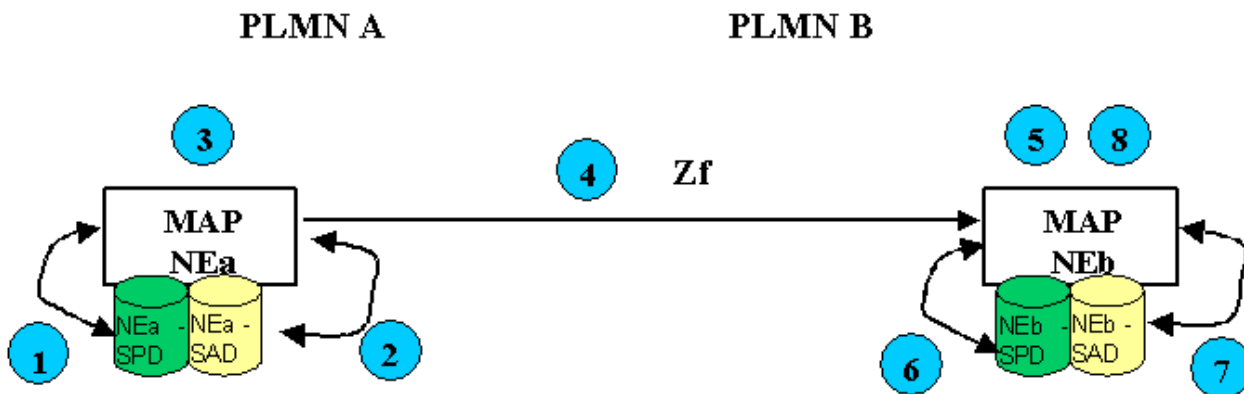

Figure 1. MAPsec Message Flow

[Editor's Note: Message flows need to be changed to account for automatic key management](#)

According to Figure 1, when MAP-NEa (NEa) from PLMN A wishes to communicate with a MAP-NEb (NEb) of PLMN B using MAP protocol, the process is the following:

As the Sending Entity, NEa performs the following actions during the outbound processing of every MAP message:

1. NEa checks its Security Policy Database (SPD) to check if MAP security mechanisms shall be applied towards PLMN B:
 - a) If the SPD does not mandate the use of MAPsec towards PLMN B, then normal MAP communication procedures will be used and the process continues in step 4.b.
 - b) If the SPD mandates the use of MAPsec towards PLMN B, then the process continues at step 2.
 - c) If no valid entry in the SPD is found for PLMN B, then the communication is aborted and an error is returned to.
2. NEa checks its Security Association Database (SAD) for a valid Security Association (SA) to be used towards PLMN B. In the case where more than one valid SA is available at the SAD, NEa shall choose the one expiring the sooner.
 - a) In case protection of MAP messages towards PLMN B is not possible (e.g. no SA available, invalid SA...), then the communication is aborted and an error is returned to MAP user.
 - b) If a valid SA exists but the MAP dialogue being handled does not require protection (Protection Mode 0 applies to all the components of the dialogue), then either the original MAP message in cleartext is sent in step 4.b, or a MAPsec message with Protection Mode 0 is created in step 3.
 - c) If a valid SA exists and the MAP dialogue being handled requires protection, then the process continues at step 3.
3. NEa constructs the MAPsec message towards NEb using the parameters (keys, algorithms and protection profiles) found in the SA.
4. NEa generates either:
 - a) MAPsec message towards NEb.

- b) An unprotected MAP message in the event that the SPD towards NEb or protection profiles for that specific MAP dialogue so allows it (1.a. or 2.b.).

At the Receiving Entity, NEb performs the following actions during the inbound processing of every MAP message it received:

- 5. If an unprotected MAP message is received, the process continues with step 6.

Otherwise, NEb decomposes the received MAPsec message and retrieves basic information to apply security measures ('SPI', 'sending PLMN-ID', 'TVP', 'IV' and 'Original Component Identifier').

Freshness of the protected message is checked at this time. If the Time Variant Parameter (TVP) received in the protected message is out of the acceptable window then the message shall be discarded and an error is returned to MAP user. No error message is returned to NEa.

- 6. NEb checks the SPD:

An unprotected MAP message is received:

- a) If an unprotected MAP message is received and fallback to unprotected mode is allowed, then the unprotected MAP message is simply processed (Process goes to END)
- b) If an unprotected MAP message is received and the 'MAPsec operation components table' of the SPD does not mandate the use of MAPsec for the included 'Original Component Identifier', then the unprotected MAP message is simply processed (Process goes to END)
- c) If an unprotected MAP message is received, the 'MAPsec operation components table' of the SPD mandates the use of MAPsec for the included 'Original Component Identifier' and fallback to unprotected mode is NOT allowed, then the message is discarded.

If the MAP dialogue is still open and it is waiting for an answer, NEb also reports an error back to NEa.

A MAPsec message is received:

- d) If no valid entry in the SPD is found for PLMN A, then the message is discarded and an error is reported to MAP user.

If the MAP dialogue is still open and it is waiting for an answer, NEb also reports an error back to NEa.

- e) If a MAPsec message is received, but the SPD indicates that MAPsec is NOT to be used, then the message is discarded and an error is reported to MAP user.

If the MAP dialogue is still open and it is waiting for an answer, NEb also reports an error back to NEa.

- f) If a MAPsec message is received and the SPD indicates that MAPsec is required, then the process continues at step 7.

- 7. NEb checks its SAD to retrieve the relevant SA-information for processing of the MAPsec message:

- a) If the received SPI points to a valid SA, then the process continues at step 8.
- b) If the received SPI does not point to a valid SA, the message is discarded and an error is reported to MAP user. If the MAP dialogue is still open and it is waiting for an answer, NEb also reports an error back to NEa.

- 8. Integrity and encryption mechanisms are applied on the message using the information in the SA (Keys, algorithms, protection profiles).

- a) If the result after applying such mechanisms is NOT successful then the message is discarded and an error is reported to MAP user. If the MAP dialogue is still open and it is waiting for an answer, NEb also reports an error back to NEa.
- b) If the result after applying such procedures is successful, then NEb has the cleartext MAP message NEa originally wanted to send NEb. The cleartext MAP message can now be processed (Process goes to END)

END: A cleartext MAP message is available at NEb.

In the event the received message at NEb requires an answer to NEa (Return Result/Error), NEb will perform the process in steps 1 to 4 acting as the Sender and NEa will perform the process in steps 5 to 8 acting as the Receiver.

In the event a MAPsec enabled NE initiated a secured MAP communication towards a non-MAPsec enabled NE and the MAPsec enabled NE received an error indication of such circumstance (i.e. "ApplicationContextNotSupported"). The MAPsec enabled NE shall check whether "Fallback to Unprotected Mode" is allowed:

- If NOT allowed, then the communication is aborted.
- If allowed, then the MAPsec enabled NE shall send an unprotected MAP message instead.

The same procedures shall apply to secure MAP communications between MAP-NEs in the same PLMN.

NOTE: Because various error cases may be caused by active attacks, it is highly recommended that the cases are reported to the management system.

Annex **BC** (informative): Change history

Change history							
Date	TSG #	TSG Doc.	CR	Rev	Subject/Comment	Old	New
June 2001	SP_12	SP-010322			Presented to TSG SA #12 and approved (Release 4)	2.0.0	4.0.0
Sept 2001	SP_13	SP-010496	001		All messages of the same application context shall be applied MAPsec or not at all	4.0.0	4.1.0
Sept 2001	SP_13	SP-010497	002		Clarification of Scope	4.0.0	4.1.0
Sept 2001	SP_13	SP-010498	005	1	Clarifications in SPD and SAD contents	4.0.0	4.1.0
Sept 2001	SP_13	SP-010499	007		MAPsec Message Flow including extra SPD table	4.0.0	4.1.0
Sept 2001	SP_13	SP-010500	008	1	Correction to security policy requirements	4.0.0	4.1.0
Sept 2001	SP_13	SP-010501	009		Content and identifiers of a MAPSec SA	4.0.0	4.1.0
Sept 2001	SP_13	SP-010502	010		MIA key length unspecified	4.0.0	4.1.0
Sept 2001	SP_13	SP-010503	011		MAC calculation in PM2	4.0.0	4.1.0

3GPP TS 33.200 V04.1.10 (2001-1109)

Technical Specification

**3rd Generation Partnership Project;
Technical Specification Group Services and System Aspects;
3G Security;
Network Domain Security;
MAP application layer security
(Release 54)**



The present document has been developed within the 3rd Generation Partnership Project (3GPP™) and may be further elaborated for the purposes of 3GPP.

The present document has not been subject to any approval process by the 3GPP Organizational Partners and shall not be implemented. This Specification is provided for future development work within 3GPP only. The Organizational Partners accept no liability for any use of this Specification. Specifications and reports for implementation of the 3GPP™ system should be obtained via the 3GPP Organizational Partners' Publications Offices.

Keywords

Security, Core Network, MAP, Key management

3GPP

Postal address

3GPP support office address

650 Route des Lucioles - Sophia Antipolis
Valbonne - FRANCE
Tel.: +33 4 92 94 42 00 Fax: +33 4 93 65 47 16

Internet

<http://www.3gpp.org>

Copyright Notification

No part may be reproduced except as authorized by written permission.
The copyright and the foregoing restriction extend to reproduction in all media.

© 2001, 3GPP Organizational Partners (ARIB, CWTS, ETSI, T1, TTA, TTC).
All rights reserved.

Contents

Foreword.....	5
Introduction.....	5
1 Scope.....	6
2 References.....	6
3 Definitions, symbols and abbreviations.....	6
3.1 Definitions.....	6
3.2 Symbols.....	7
3.3 Abbreviations.....	7
3.4 Conventions.....	8
4 Principles of MAP application layer security.....	8
5 MAP security (MAPsec).....	9
5.1 Key Administration Centres (KACs).....	9
5.2 Properties and tasks of MAPsec enabled network elements.....	10
5.3 Policy requirements for the MAPsec Security Policy Database (SPD).....	11
5.4 MAPsec security association attribute definition.....	11
5.5 MAPsec structure of protected messages.....	12
5.5.1 MAPsec security header.....	12
5.5.2 Protected payload.....	13
5.5.2.1 Protection Mode 0.....	13
5.5.2.2 Protection Mode 1.....	13
5.5.2.3 Protection Mode 2.....	13
5.6 MAPsec algorithms.....	14
5.6.1 Mapping of MAP-SA encryption algorithm identifiers.....	14
5.6.1.1 Description of MEA-1.....	14
5.6.2 Mapping of MAP-SA integrity algorithm identifiers.....	14
5.6.2.1 Description of MIA-1.....	14
5.6.3 Construction of IV.....	14
6 MAPsec protection profiles.....	15
6.1 Granularity of protection.....	15
6.2 MAPsec protection groups.....	15
6.2.1 MAPsec protection groups.....	15
6.2.1.1 MAP-PG(0) – No Protection.....	15
6.2.1.2 MAP-PG(1) – Protection for Reset.....	15
6.2.1.3 MAP-PG(2) – Protection for Authentication Information except Handover Situations.....	16
6.2.1.4 MAP-PG(3) – Protection for Authentication Information in Handover Situations.....	16
6.2.1.5 MAP-PG(4) – Protection of non location dependant HLR data.....	16
6.3 MAPsec protection profiles.....	17
7 Inter-domain Security Association and Key Management Procedures.....	17
7.1 MAPsec required modifications to standard IKE.....	17
8 Local Security Association Distribution.....	18
8.1 SA lifetime supervision at KAC and NEs.....	18
8.2 Request SA Procedure.....	18

Annex A (normative): MAPsec message flows	21
Annex B (informative): Change history	24
Foreword.....	4
Introduction.....	4
1— Scope	5
2— References	5
3— Definitions, symbols and abbreviations.....	5
3.1— Definitions.....	5
3.2— Symbols.....	6
3.3— Abbreviations	6
3.4— Conventions	6
4— Principles of MAP application layer security	7
5— MAP security (MAPsec)	7
5.1— Security services provided by MAPsec.....	7
5.2— Properties and tasks of MAPsec-enabled network elements	7
5.3— Policy requirements for the MAPsec Security Policy Database (SPD).....	8
5.4— MAPsec security association attribute definition.....	8
5.5— MAPsec structure of protected messages.....	9
5.5.1— MAPsec security header	9
5.5.2— Protected payload	10
5.5.2.1— Protection Mode 0	10
5.5.2.2— Protection Mode 1	10
5.5.2.3— Protection Mode 2	10
5.6— MAPsec algorithms.....	11
5.6.1— Mapping of MAP-SA encryption algorithm identifiers.....	11
5.6.1.1— Description of MEA-1	11
5.6.2— Mapping of MAP-SA integrity algorithm identifiers	11
5.6.2.1— Description of MIA-1	11
5.6.3— Construction of IV.....	11
6— MAPsec protection profiles	12
6.1— Granularity of protection.....	12
6.2— MAPsec protection groups.....	12
6.2.1— MAPsec protection groups	12
6.2.1.1— MAP-PG(0)— No Protection	12
6.2.1.2— MAP-PG(1)— Protection for Reset.....	12
6.2.1.3— MAP-PG(2)— Protection for Authentication Information except Handover Situations.....	13
6.2.1.4— MAP-PG(3)— Protection for Authentication Information in Handover Situations.....	13
6.2.1.5— MAP-PG(4)— Protection of non-location dependant HLR data	13
6.3— MAPsec protection profiles.....	14
Annex A (informative):— Guidelines for manual key management	15
A.1— Inter-domain Security Association and Key Management Procedures	15
A.2— Local Security Association Distribution.....	15
Annex B (normative):— MAPsec message flows	16
Annex C (informative):— Change history	19

Foreword

This Technical Specification has been produced by the 3rd Generation Partnership Project (3GPP).

The contents of the present document are subject to continuing work within the TSG and may change following formal TSG approval. Should the TSG modify the contents of the present document, it will be re-released by the TSG with an identifying change of release date and an increase in version number as follows:

Version x.y.z

where:

- x the first digit:
 - 1 presented to TSG for information;
 - 2 presented to TSG for approval;
 - 3 or greater indicates TSG approved document under change control.
- y the second digit is incremented for all changes of substance, i.e. technical enhancements, corrections, updates, etc.
- z the third digit is incremented when editorial only changes have been incorporated in the document.

Introduction

The absence of security in Signalling System No. 7 (SS7) networks is an identified security weakness in 2G systems. This was formerly perceived not to be a problem, since the SS7 networks were the provinces of a small number of large institutions. This is no longer the case, and so there is now a need for security precautions.

For 3G systems it is a clear goal to be able to protect the core network signalling protocols, and by implication this means that security solutions must be found for both SS7 and IP based protocols.

Various protocols and interfaces are used for control plane signalling within and between core networks. The security services that have been identified as necessary are confidentiality, integrity, authentication and anti-replay protection. These will be ensured by standard procedures, based on cryptographic techniques.

1 Scope

This technical specification covers the security mechanisms and procedures necessary to protect the MAP protocol. The complete set of enhancements and extensions to facilitate security protection for the MAP protocol is termed MAPsec and it covers transport security in the MAP protocol itself and the security management procedures.

The security mechanisms specified for MAP are on the application layer. This means that MAPsec is independent of the network and transport protocols to be used. [This specification also includes automatic key management mechanisms to update the security associations used to protect the MAP signalling.](#)

This technical specification contains the stage-2 specification for security protection of the MAP protocol. The actual implementation (stage-3) specification can be found in the MAP stage-3 specification, TS 29.002 [4].

~~NOTE:— It is explicitly noted that automated key management and key distribution is not part of Rel-4. All key management and key distribution in Rel-4 must therefore be carried out by other means. (See Annex A)~~

2 References

The following documents contain provisions which, through reference in this text, constitute provisions of the present document.

- References are either specific (identified by date of publication, edition number, version number, etc.) or non-specific.
- For a specific reference, subsequent revisions do not apply.
- For a non-specific reference, the latest version applies. In the case of a reference to a 3GPP document (including a GSM document), a non-specific reference implicitly refers to the latest version of that document *in the same Release as the present document*.

- [1] 3G TS 21.133: Security Threats and Requirements.
- [2] 3G TS 21.905: 3G Vocabulary.
- [3] 3G TS 23.060: General Packet Radio Service (GPRS); Service description; Stage 2.
- [4] 3G TS 29.002: Mobile Application Part (MAP) specification.
- [5] ISO/IEC 10116: "Information technology -- Security techniques -- Modes of operation for an n-bit block cipher", Ed.2, 1997-04-17.
- [6] ISO/IEC 9797: "Information technology -- Security techniques -- Message Authentication Codes (MACs) -- Part 1: Mechanisms using a block cipher", Ed.1, 1999-12-16.
- [7] [draft-arkko-map-doi-04-pa2.txt: The MAP Security Domain of Interpretation for ISAKMP](#)

3 Definitions, symbols and abbreviations

3.1 Definitions

For the purposes of the present document, the following terms and definitions apply.

Anti-replay protection: Anti-replay protection is a special case of integrity protection. Its main service is to protect against replay of self-contained packets that already have a cryptographical integrity mechanism in place.

Confidentiality: The property that information is not made available or disclosed to unauthorised individuals, entities or processes.

Data integrity: The property that data has not been altered in an unauthorised manner.

Data origin authentication: The corroboration that the source of data received is as claimed.

Entity authentication: The provision of assurance of the claimed identity of an entity.

Key freshness: A key is fresh if it can be guaranteed to be new, as opposed to an old key being reused through actions of either an adversary or authorised party.

Security Association: A logical connection created for security purposes. All traffic traversing a security association is provided the same security protection. The security association specifies protection levels, algorithms to be used, lifetime of the connection etc.

MAPsec: The complete collection of protocols and procedures needed to protect MAP messages. MAPsec can be divided into three main parts. These are (1) MAPsec transport security, (2) MAPsec Local Security Association distribution and (3) MAPsec Inter-domain Security Association and Key Management procedures.

3.2 Symbols

For the purposes of the present document, the following symbols apply:

f6	MAP encryption algorithm
f7	MAP integrity algorithm
Zd	MAPsec interface between KACs belonging to different PLMNs
Ze	MAPsec interface between KACs and MAP-NEs within the same PLMN
Zf	The MAP application layer security interface between MAP-NEs engaged in security protected signalling.

3.3 Abbreviations

For the purposes of the present document, the following abbreviations apply:

AES	Advanced Encryption Standard
DoI	Domain of Interpretation
ESP	Encapsulating Security Payload
FALLBACK	Fallback to unprotected mode indicator
IETF	Internet Engineering Task Force
IKE	Internet Key Exchange
IP	Internet Protocol
IPsec	IP security - a collection of protocols and algorithms for IP security incl. key mngt.
ISAKMP	Internet Security Association Key Management Protocols
IV	Initialisation Vector
KAC	Key Administration Centre
MEK	MAP Encryption Key
MAC	Message Authentication Code
MAC-M	MAC used for MAP
MAP	Mobile Application Part
MAP-NE	MAP Network Element
MAPsec	MAP security – the MAP security protocol suite
MEA	MAP Encryption Algorithm identifier
MEK	MAP Encryption Key
MIA	MAP Integrity Algorithm identifier
MIK	MAP Integrity Key
NDS	Network Domain Security
NE	Network Entity
PPI	Protection Profile Indicator
PROP	Proprietary field
SA	Security Association

SADB	Security Association DataBase
SPD	Security Policy Database (sometimes also referred to as SPDB)
SPI	Security Parameters Index
TVP	Time Variant Parameter

3.4 Conventions

All data variables in this specification are presented with the most significant substring on the left hand side and the least significant substring on the right hand side. A substring may be a bit, byte or other arbitrary length bitstring. Where a variable is broken down into a number of substrings, the leftmost (most significant) substring is numbered 0, the next most significant is numbered 1, and so on through to the least significant.

4 Principles of MAP application layer security

This technical specification defines mechanisms for protecting the MAP protocol at the application layer. The MAP protocol may also be protected at the network layer when IP is used as the transport protocol. However, whenever interworking with networks using SS7-based transport is necessary, protection at the application layer shall be used.

The security measures specified in this TS are only fully useful if all interconnected operators use them. In order to prevent active attacks all interconnected operators must at least use MAPsec with the suitable protection levels as indicated in this specification and treat the reception of all MAP messages (protected and unprotected) in a uniform way in the receiving direction.

Before protection can be applied, Security Associations (SA) needs to be established between the respective MAP network elements. Security associations define, among other things, which keys, algorithms, and protection profiles to use to protect MAP signalling. The necessary MAP-SAs between networks are negotiated between the respective [Key Administration Centres \(KACs\) of the networks/network operators](#). The negotiated SA will be effective PLMN-wide and distributed to all network elements, which implement MAP application layer security within the PLMN. Signalling traffic protected at the application layer will, for routing purposes, be indistinguishable from unprotected traffic to all parties except for the sending and receiving entities.

[Figure 1](#) gives an overview of the architecture used for MAPsec.

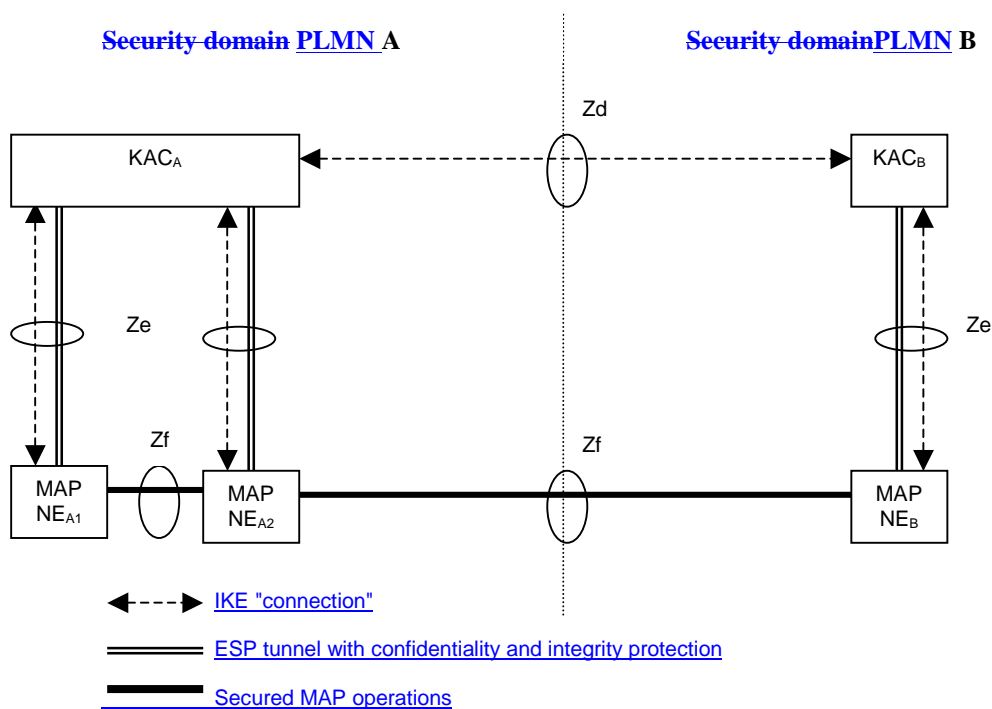

Figure 1: Overview of the Zd, Ze and Zf interfaces

The following interfaces are defined MAPsec.

- Zd-interface (KAC-KAC)

The Zd-interface is used to negotiate MAPsec Security Associations (SAs) between PLMNs. The traffic over Zd consists only of IKE negotiations. The negotiated MAPsec SAs are valid on a PLMN to PLMN basis.

- Ze-interface (KAC-NE)

The Ze-interface is located between MAP-NEs and a KAC from the same PLMN. This interface is used for transport of MAPsec SAs and the relevant security policy information from the KAC to the MAP-NE. The KAC and the MAP-NE are able to establish and maintain an ESP tunnel between them. Whether the tunnel is established when needed or a priori is for the PLMN operator to decide.

- The Zf-interface (NE-NE)

The Zf-interface is located between MAP-NEs. The MAP-NEs may be from the same PLMN or from different PLMNs (as shown in figure 1). The MAP-NEs use MAPsec SAs received from a KAC to protect the MAP operations. The MAP operations within the MAP dialogue are protected selectively as specified in the applied MAPsec protection profile. The interface applies to all MAPsec transactions, intra- or inter-PLMN.

Protection at the application layer implies changes to the application protocol itself to allow for the necessary security functionality to be added.

The MAP application layer security interface between MAP-NEs engaged in security protected signalling is referred to in this specification as the Zf interface. The interface applies to all MAPsec transactions, intra- or inter-PLMN.

The security services provided by MAPsec are:

- data integrity;
- data origin authentication;
- anti-replay protection;
- confidentiality (optional).

Annex AB includes detailed procedures on how secure MAP signalling is performed between two MAP-NEs.

5 MAP security (MAPsec)

5.1 Security services provided by MAPsec Properties and tasks of Key Administration Centres (KACs)

The security services provided by MAPsec are:

- data integrity;
- data origin authentication;
- anti-replay protection;
- confidentiality (optional).

Key Administration Centres (KACs) are entities that are used for negotiating MAPsec SAs on behalf of MAP-NEs. The KACs are defined to handle communication over these interfaces:

- the Zd-interface, which is located between KACs from different PLMNs. The IKE protocol with support for MAPsec DoI shall be used over this interface.

- the Ze-interface, which is located between a KAC and a MAP-NE within the same PLMN is used to transfer MAPsec SAs and security policy from KACs to MAP-NEs. The IKE and ESP protocols may be used to negotiate and secure the connection between the KAC and the MAP-NE.

When MAP-NEs need to establish a secure connection towards another MAP-NEs they will request a MAPsec SA from the KAC. The KAC will then either provide an existing MAPsec SAs or negotiate a new MAPsec SA, before returning the MAPsec SA to the MAP-NE.

A MAPsec SA is valid for all MAP communication between the two PLMNs for which it is negotiated. That is, the same MAPsec SA shall be provided to all MAP-NE in PLMN A when communicating with MAP-NEs in PLMN B. Each PLMN can have one or more KACs. Each KAC will be defined to negotiate MAPsec SAs with a well-defined set of reachable PLMNs. The number of KACs in a PLMN will depend on the need to differentiate between the externally reachable destinations, the need to balance the traffic load and to avoid single point of failures.

KACs perform the following operations:

- Negotiate SAs for MAPsec with other KACs belonging to other network operators. This action is triggered either by request for a MAP-SA by a NE or by policy enforcement when MAP-SAs always should be available. MAP-SAs negotiation is performed at Zd-interface using IKE protocol with MAPsec DoI.
- Convert specific negotiated SA parameter so that they can be understood by NEs. In particular, the KAC shall convert negotiated SA duration in seconds as negotiated in MAPsec DoI to UTC absolute time format.
- Perform refresh of MAP-SAs. Triggered internally by SA lifetime supervision, which is depends on the policies set by the operator.
- Distribute MAP-SA and policy information to NEs belonging to the same PLMN as the KAC.
- (Optional) KAC may be able to establish IPSec connections supporting IKE with IPSec DOI in order to secure transmission of MAP-SAs to the NEs within its PLMN.

KACs are also responsible for the maintenance of the following databases:

- KAC-SPDB-MAP: Defines the scope, the security policy, in which MAP-SAs may be negotiated (e.g. allowed MAP-PPs, Algorithms, SA-lifetimes). This database is updated on operator initiative in the framework of the roaming agreements.
- NE-SPD-MAP: A database in a KAC containing the MAP security policy information that will be used by an NE in protecting MAP messages (e.g. value of "Fallback to unprotected Mode Indicator" and table of protected MAPsec operation components). This is held to update the NEs.
- NE-SADB-MAP: A database in a KAC containing MAP-SA information. This is held to allow the KAC to update the NE.
- (Optional) KAC-SPDB-IP: Defines the scope, the security policy, in which IPSec-SAs may be negotiated at the Ze-interface.
- (Optional) KAC-SADB-IP: Containing IPSec-SAs for protection of IP traffic between the KAC and NEs over the Ze-interface.

KACs are responsible for security sensitive operations and shall be physically secured. They shall offer capabilities for the secure storage of long-term keys used for IKE authentication.

5.2 Properties and tasks of MAPsec enabled network elements

MAPsec MAP-NEs shall maintain the following databases:

- NE-SPD-MAP: A database in an NE containing MAP security policy information (see clause 5.3);
- NE-SADB-MAP: A database in an NE containing MAP-SA information. MAP-NEs shall monitor the SA lifetime and expired SAs shall be deleted from the database (see clause 5.4).
- (Optional) NE-SPDB-IP: Defines the scope, the security policy, in which IPSec-SAs may be negotiated at the Ze-interface.

- [\(Optional\) NE-SADB-IP: Containing IPSec-SAs for protection of IP traffic between the KAC and NEs over the Ze-interface.](#)

MAPsec MAP-NEs shall be able to perform the following operations:

- [Secure MAP signalling \(i.e. send/receive protected or unprotected messages\) according to information in NE-SPD-MAP and NE-SADB-MAP. The structure of protected messages is defined in clause 5.5 and the protection algorithms are defined in clause 5.6.](#)
- [Communicate with the KAC in the same PLMN in order that the NE-SPD-MAP and NE-SADB-MAP in the NE can be updated.](#)
- [\(Optional\) NE may be able to establish IPSec connections supporting IKE with IPSec DOI in order to secure transmission of MAP-SAs to the KAC within its PLMN.](#)

5.3 Policy requirements for the MAPsec Security Policy Database (SPD)

The security policies for MAPsec key management are specified in the NE's SPD. SPD entries define which MAP operation components are protected and which MAP SAs (if any) to use to protect MAP signalling based on the PLMN of the peer NE. There can be no local security policy definitions for individual NEs. Instead, SPD entries of different NE within the same PLMN shall be identical.

Fallback to unprotected mode:

- The "fallback to unprotected mode" (enabled/disabled) shall be available to the MAP-NE before any communication towards other MAP-NEs can take place. For the receiving direction, it is sufficient to have a single parameter indicating whether fallback for incoming messages is allowed or not. For the sending direction, the information should indicate for each destination PLMN whether fallback for outgoing messages is allowed or not;
- The use of the fallback indicators is specified in Annex [AB](#);
- The security measures specified in this TS are only fully useful for a particular PLMN if it disallows fallback to unprotected mode for MAP messages received from any other PLMN.

Table of MAPsec operation components:

- The security policy database (SPD) shall contain a table of MAPsec operation components for incoming messages. This table contains operation components which have to be carried in MAPsec messages with Protection Mode 1 or 2. The use of MAPsec operation components is specified in Annex [AB](#).

Uniformity of protection profiles:

- In order to ensure full protection, a particular PLMN shall use the same protection profile for incoming MAPsec messages from all other PLMNs. In particular, full protection is not ensured when protection profile A (no protection) is used for some source PLMNs and other profiles are used for other source PLMNs.

Editor's note: Some issues need to be investigated: Non-synchronised expiration times issue, mechanism to distinguish inbound/outbound SPDs ?

5.4 MAPsec security association attribute definition

The MAPsec security association shall contain the following data elements:

- MAP Encryption Algorithm identifier (MEA):

Identifies the encryption algorithm. Mode of operation of algorithm is implicitly defined by the algorithm identifier. Mapping of algorithm identifiers is defined in clause 5.6.

- MAP Encryption Key (MEK):

Contains the encryption key. Length is defined according to the algorithm identifier.

- MAP Integrity Algorithm identifier (MIA):

Identifies the integrity algorithm. Mode of operation of algorithm is implicitly defined by the algorithm identifier. Mapping of algorithm identifiers is defined in section 5.6.

- MAP Integrity Key (MIK):

Contains the integrity key. Length is defined according to the algorithm identifier.

- Protection Profile Identifier (PPI):

Identifies the protection profile. Length is 16 bits. Mapping of profile identifiers is defined in section 6.

- SA Lifetime:

Defines the actual expiry time of the SA. The expiry of the lifetime shall be given in UTC time.

Editor's Note: The exact format and length to be defined.

A MAPsec SA is uniquely identified by a destination PLMN-Id and a Security Parameters Index, SPI. As a consequence, during SA creation, the SPI is always chosen by the receiving side ([i.e. the SPI for MAP communications from PLMN A to PLMN B is selected by KAC in PLMN B](#)).

If the SA is to indicate that MAPsec is not to be applied then all the algorithm attributes shall contain a NULL value.

5.5 MAPsec structure of protected messages

MAPsec provides for three different protection modes and these are defined as follows:

Protection Mode 0: No Protection

Protection Mode 1: Integrity, Authenticity

Protection Mode 2: Confidentiality, Integrity, and Authenticity

MAP operations protected by means of MAPsec consist of a Security Header and the Protected Payload. Secured MAP messages have the following structure:

Security Header	Protected Payload
-----------------	-------------------

In all three protection modes, the security header is transmitted in cleartext.

In protection mode 2 providing confidentiality, the protected payload is essentially the encrypted payload of the original MAP message. For integrity and authenticity in protection mode 1, the message authentication code is calculated on the security header and the payload of the original MAP message in cleartext and it is included in the protected payload. The message authentication code in protection mode 2 is calculated on the security header and the encrypted payload of the original MAP message. In protection mode 0 no protection is offered, therefore the protected payload is identical to the payload of the original MAP message.

5.5.1 MAPsec security header

The security header is a sequence of the following data elements:

Security header = TVP // NE-Id // Prop // Sending PLMN-Id // SPI // Original component Id

- TVP:

The TVP is used for replay protection of Secured MAP operations is a 32 bit time-stamp. The receiving network entity will accept an operation only if the time-stamp is within a certain time-window. The resolution of the clock from which the time-stamp is derived is 0.1 seconds. The size of the time-window at the receiving network entity is not standardised.

- NE-Id:

6 octets used to create different IV values for different NEs within the same TVP period. It is necessary and sufficient that *NE-Id* is unique per PLMN. (This is sufficient because sending keys are unique per PLMN.) The NE-Id shall be the E.164 global title of the NE without the MCC and MNC.

- Proprietary field (PROP):

4 octets used to create different IV values for different protected MAP messages within the same TVP period for one NE. The usage of the proprietary field is not standardised.

- Sending PLMN-Id:

PLMN-Id is the ID number of the sending Public Land Mobile Network (PLMN). The value for the PLMN-Id is a concatenation of the Mobile Country Code (MCC) and Mobile Network Code (MNC) of the sending network.

- Security Parameters Index (SPI):

SPI is an arbitrary 32-bit value that is used in combination with the [destination sender's](#) PLMN-Id to uniquely identify a MAP-SA.

- Original Component identifier:

Identifies the type of component (invoke, result or error) within the MAP operation that is being securely transported (Operation identified by operation code, Error defined by Error Code or User Information).

5.5.2 Protected payload

5.5.2.1 Protection Mode 0

Protection Mode 0 offers no protection at all. Therefore, the protected payload of Secured MAP messages in protection mode 0 is identical to the original MAP message payload in cleartext.

5.5.2.2 Protection Mode 1

The protected payload of Secured MAP messages in protection mode 1 takes the following form:

Cleartext f7(Security Header Cleartext)

where "Cleartext" is the payload of the original MAP message in cleartext. Therefore, in Protection Mode 1 the protected payload is a concatenation of the following information elements:

- Cleartext
- Message authentication code (MAC-M) calculated by the function f7

Authentication of origin and message integrity are achieved by applying the message authentication code (MAC-M) function f7 with the integrity key defined by the security association to the concatenation of Security Header and Cleartext. The MAC-M length shall be 32 bits.

5.5.2.3 Protection Mode 2

The protected payload of Secured MAP Messages in protection mode 2 takes the following form:

f6(Cleartext) f7(Security Header f6(Cleartext))

where "Cleartext" is the original MAP message payload in cleartext. Confidentiality is achieved by encrypting Cleartext using the encryption function f6 with the confidentiality key defined by the security association and the initialisation vector (IV). Authentication of origin and integrity are achieved by applying the message authentication code (MAC-M) function f7 with the integrity key defined by the security association to the concatenation of Security Header and ciphertext. The MAC-M length shall be 32 bits. The length of the ciphertext is the same as the length of the cleartext.

5.6 MAPsec algorithms

5.6.1 Mapping of MAP-SA encryption algorithm identifiers

The MEA algorithm indication fields in the MAP-SA are used to identify the encryption algorithm and algorithm mode to be used. The mapping of algorithm identifiers is defined below.

Table 1: MAP encryption algorithm identifiers

MAP Encryption Algorithm identifier	Description
0	Null
1	AES in a stream cipher mode (MANDATORY)
:	-not yet assigned-
15	-not yet assigned-

5.6.1.1 Description of MEA-1

The MEA-1 algorithm is the ISO/IEC 10116 Counter Mode with parameter $j=128$ bits, $SV=IV$ and truncation of the last block is according to the method described in ISO/IEC 10116 Annex A.5.3. See ISO/IEC 10116 [5] for more information.

Editor's Note: More specification on the mode of operation for MEA-1 may be required.

5.6.2 Mapping of MAP-SA integrity algorithm identifiers

The MIA algorithm indication fields in the MAP-SA are used to identify the integrity algorithm and algorithm mode to be used. The mapping of algorithm identifiers is defined below.

Table 2: MAP integrity algorithm identifiers

MAP Integrity Algorithm identifier	Description
0	Null
1	AES in a CBC MAC mode with a 128-bit key (MANDATORY)
:	-not yet assigned-
15	-not yet assigned-

5.6.2.1 Description of MIA-1

The MIA-1 algorithm is the ISO/IEC 9797 Part 1: padding method 2, MAC algorithm 1 (initial transformation=1, output transformation=1). No IV used. The MAC-length m is 32-bits (see clause 5.6.1). See ISO/IEC 9797 [6] for more information.

5.6.3 Construction of IV

The IV used in the encryption shall be constructed as follows:

$$IV = TVP \parallel NE-Id \parallel Prop \parallel Pad$$

The padding field is used to expand $TVP \parallel NE-Id \parallel Prop$ to the IV length required by the cryptographic scheme in use.

The IV length shall be 16 octets. The padding (Pad) shall be 2 octets with all bits set to zero.

6 MAPsec protection profiles

6.1 Granularity of protection

MAPsec protection is specified per MAP operation component.

6.2 MAPsec protection groups

This section specifies groups of messages and their protection modes at the operation component level. Individual protection groups or particular combinations of groups can then be used to construct protection profiles as specified in section 6.3.

Combinations of overlapping protection groups are forbidden. Forbidden combinations are explicitly specified in 6.2.1 below.

The concept of "protection levels" is introduced to administrate the protection mode on operation component level. A protection level of an operation determines the protection modes used for the operation's components according to the following table.

Table 3: MAPsec protection levels

Protection level	Protection mode for <i>invoke</i> component	Protection mode for <i>result</i> component	Protection mode for <i>error</i> component
1	1	0	0
2	1	1	0
3	1	2	0
4	2	1	0
5	2	2	0
6	2	0	0

6.2.1 MAPsec protection groups

6.2.1.1 MAP-PG(0) – No Protection

This MAP-PP does not contain any operation and it does not protect any information. It is useful however to have a "null" MAP-PP to use in situations where no security is required or is an option. This protection group cannot be combined with any other protection group.

6.2.1.2 MAP-PG(1) – Protection for Reset

Table 4: PG(1) – Protection for Reset

Application Context/Operation	Protection Level
ResetContext-v2/ Reset	1
ResetContext-v1/ Reset	1

6.2.1.3 MAP-PG(2) – Protection for Authentication Information except Handover Situations

Table 5: PG(2) – Protection for Authentication Information except Handover Situations

Application Context/Operation	Protection Level
InfoRetrievalContext-v3/ Send Authentication Info	3
InfoRetrievalContext-v2/ Send Authentication Info	3
InfoRetrievalContext-v1/ Send Parameters	3
InterVlrInfoRetrievalContext-v3/ Send Identification	3
InterVlrInfoRetrievalContext-v2/ Send Identification	3

6.2.1.4 MAP-PG(3) – Protection for Authentication Information in Handover Situations

Table 6: PG(3) – Protection for Authentication Information in Handover Situations

Application Context/Operation	Protection Level (Component level)
HandoverControlContext-v3/ Prepare Handover (Note that the AC contains also other operations)	4
HandoverControlContext-v3/ Forward Access Signalling (Note that the AC contains also other operations)	4
HandoverControlContext-v2/ Prepare Handover (Note that the AC contains also other operations)	4
HandoverControlContext-v2/ Forward Access Signalling (Note that the AC contains also other operations)	4
HandoverControlContext-v1/ Perform Handover (Note that the AC contains also other operations)	4
HandoverControlContext-v1/ Forward Access Signalling (Note that the AC contains also other operations)	4

6.2.1.5 MAP-PG(4) – Protection of non location dependant HLR data

Table 7: PG(4) – Protection of non location dependant HLR data

Application Context/Operation	Protection Level
AnyTimInfoHandlingContext-v3 / AnyTimeModification	1
SubscriberDataMngtContext-v3 / DeleteSubscriberData	1

Editor's Note: Protection Group 4 is not complete.

6.3 MAPsec protection profiles

Protection profiles can be individual protection groups or particular combinations of protection groups. MAP protection profiles are coded as a 16 bit binary number where each bit corresponds to a protection group. Currently only 5 groups are defined, the rest are reserved for future use.

Table 8: Protection profile encoding

Protection profile bit	Protection group
0	No protection
1	Reset
2	Authentication information except handover situations
3	Authentication information in handover situations
4	Non-location dependant HLR data
5-15	Reserved

Protection profiles shall be bidirectional.

The following protection profiles are defined.

Table 9: Protection profile definition

Protection profile name	Protection group				
	PG(0) <i>No protection</i>	PG(1) <i>Reset</i>	PG(2) <i>AuthInfo except handover situations</i>	PG(3) <i>AuthInfo in handover situation</i>	PG(4) <i>Non-location dependant HLR data</i>
Profile A	✓				
Profile B		✓	✓		
Profile C		✓	✓	✓	
Profile D		✓	✓	✓	✓
Profile E		✓	✓		✓

7 Inter-domain Security Association and Key Management Procedures

The overall architecture is defined in clause 5. This section only contains additional material to define the Zd-interface and the IKE protocol when used with the MAPsec DoI ([7]). Clause 7 contains material that complements the MAPsec DoI.

Editor's Note: Soft Expiry Time is not negotiated between KACS.

7.1 MAPsec required modifications to standard IKE

For MAPsec KAC←→KAC negotiation standard IKE Phase 1 shall be used. It is also required that only Main Mode shall be used for MAPsec.

A new Phase 2 mode - the MAP mode, must be introduced. The MAP mode differs from the existing IKE quick mode in the following respects:

- Payloads included to the messages of MAP mode are the same as in Quick Mode but the contents of the payloads differ in the case SA payload and ID payloads.

- Either the identity is never sent or if sent it will be the PLMID in *fgdn* or *der_ gn* encoded form (or the *key_id*).

KEYMAT for MAPsec SA template (as in the present Quick mode).

8 Local Security Association Distribution

8.1 SA lifetime supervision at KAC and NEs

In order to improve processing time of the first message in a secure communication, the KACs and/or NEs might introduce the option to always maintain SAs alive.

With this option, KACs shall control the SA lifetime and negotiate a new SA before the SA in use expires in order to maintain continuously valid SAs for all or some pre-configured network domains. When a NE requests a SA, the KAC must answer with the recent one.

In a similar way and as a configuration option, NEs might supervise the SA lifetime and request a new one before the SA in use expires.

The following considerations must be noticed:

- All nodes might try to update their SAs at the same time, so in order to prevent KAC overload, SA requests from the NEs should be randomised.
- Two SAs can be valid during the same period of time; i.e. KAC might have negotiated a fresh SA before older one has expired.

8.2 Request SA Procedure

For local security association distribution a pure pull approach has been selected. The mechanism is outlined in more detail in Figure-3.

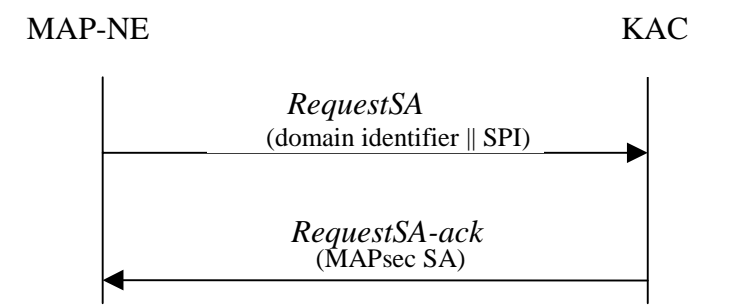

Figure 3: RequestSA procedure

The purpose of this procedure is to provide a MAP-NE with valid MAP-SA information to establish secure MAP communication with another MAP-NE.

The procedure is invoked by a MAP-NE when MAP communication towards another MAP-NE is to be initiated and no valid SA information is available at the MAP-NE SADB. Optionally, the procedure may also be initiated when the MAP-NE is configured to always maintain valid SAs.

The MAP-NE sends a *request SA* to the KAC; this message contains the domain identifier of the PLMN the MAP-NE wishes to communicate with (i.e. destination PLMNid). In the event, the MAP-NE initiated the procedure with the purpose to refresh an existing SA (just expired or about to), the SPI (pair) of the SA being replaced shall be also included.

The answer from the KAC may include one of the following responses:

- Valid SA information to secure MAP communication to and from the PLMN identified in the request.
- An indication that MAP communication towards/from that specific PLMN does not need to be secured at that moment. This indication has a limited lifetime (also included in the response) to allow future changes in policy.
- An error response informing that the KAC is not able to provide the MAP-NE with valid SA information at that moment.

In order to perform this procedure in a secure manner, the KAC and MAP-NE might be able to use IKE to negotiate, establish and maintain an ESP tunnel between them. Whether the tunnel is established is for the PLMN operator to decide.

This procedure does not allow notification from KAC to MAP-NEs. If SAs are compromised, additional measures shall be applied in order to abort new or secure communication in progress (e.g. MAP Policy).

~~Annex A (informative):
Guidelines for manual key management~~

~~A.1 — Inter-domain Security Association and Key Management Procedures~~

~~Manual Inter-domain Security Association and Key Management procedures is subject to roaming agreements.~~

~~Some important parts of an inter-domain Security Association and Key Management agreement is:~~

- ~~— to define how to carry out the initial exchange of MAPsec SAs;~~
- ~~— to define how to renew the MAPsec SAs;~~
- ~~— to define how to withdraw MAPsec SAs (including requirements on how fast to execute the withdrawal);~~
- ~~— to decide if fallback to unprotected mode is to be allowed;~~
- ~~— to decide on key lengths, algorithms, protection profiles, and SA lifetime etc (MAPsec SAs are expected to be fairly long lived).~~

~~When renewing a MAPsec SA used for incoming MAP traffic, the "old" SA should be kept in the NEs until its expiry time is reached, unless the SA renewal was due to compromise of the keys of the "old" SA, in which case the "old" compromised SA should immediately be removed from the SAD.~~

~~When renewing a MAPsec SA used for outgoing MAP traffic, the "old" SA should continue to be used by the NEs until its expiry time is reached, unless the SA renewal was due to compromise of the keys of the "old" SA in which case the "old" compromised SA should immediately be removed from the SAD. Note that one way to force the NEs to use a newly defined MAPsec SA is to distribute to NEs a new version of the SAD in which the old SA no longer exists but only the new SA.~~

~~To ease SA renewal, both PLMNs may decide to set up several MAPsec SAs in advance so that NEs can automatically switch from one SA to another SA when the former expires. In such a situation, the MAPsec SAs would have different expiry times.~~

~~A.2 — Local Security Association Distribution~~

~~Manual Local Security Association Distribution is executed entirely within one PLMN and is consequently at the discretion of the administrative authority.~~

~~The requirement on the manual distribution procedures can be summarized as follows:~~

- ~~— Procedures for transporting the relevant MAPsec SA to the MAP-NEs must be defined. In order to ensure that the MAPsec SA are present when needed, all valid MAPsec SA should be distributed to all MAP-NEs as soon as they are available.~~
- ~~— Procedures for revocation of MAPsec SAs must be defined~~

Annex **AB** (normative): MAPsec message flows

Imagine a network scenario with two MAP-NEs at different PLMNs (NEa and NEb) willing to communicate using MAPsec. Figure 1 presents the message flow.

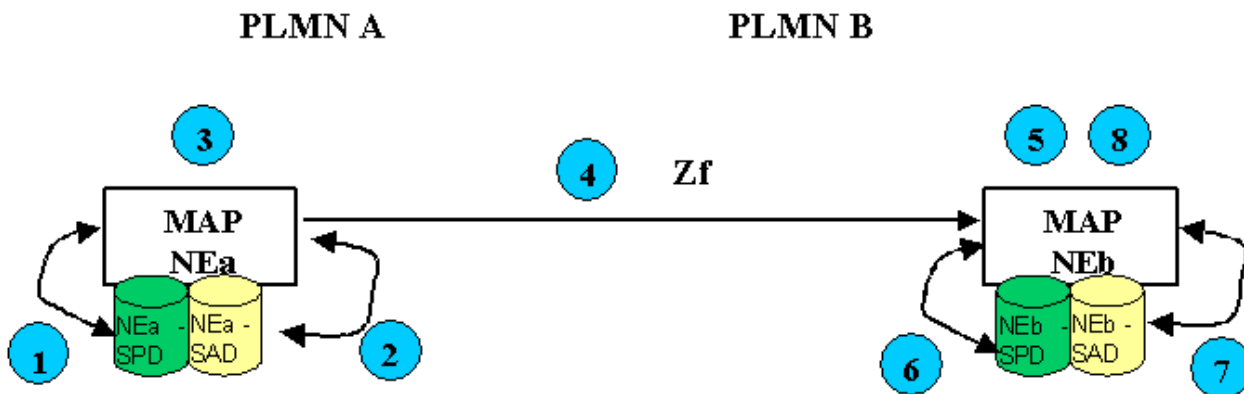

Figure 1. MAPsec Message Flow

[Editor's Note: Message flows need to be changed to account for automatic key management](#)

According to Figure 1, when MAP-NEa (NEa) from PLMN A wishes to communicate with a MAP-NEb (NEb) of PLMN B using MAP protocol, the process is the following:

As the Sending Entity, NEa performs the following actions during the outbound processing of every MAP message:

1. NEa checks its Security Policy Database (SPD) to check if MAP security mechanisms shall be applied towards PLMN B:
 - a) If the SPD does not mandate the use of MAPsec towards PLMN B, then normal MAP communication procedures will be used and the process continues in step 4.b.
 - b) If the SPD mandates the use of MAPsec towards PLMN B, then the process continues at step 2.
 - c) If no valid entry in the SPD is found for PLMN B, then the communication is aborted and an error is returned to.
2. NEa checks its Security Association Database (SAD) for a valid Security Association (SA) to be used towards PLMN B. In the case where more than one valid SA is available at the SAD, NEa shall choose the one expiring the sooner.
 - a) In case protection of MAP messages towards PLMN B is not possible (e.g. no SA available, invalid SA...), then the communication is aborted and an error is returned to MAP user.
 - b) If a valid SA exists but the MAP dialogue being handled does not require protection (Protection Mode 0 applies to all the components of the dialogue), then either the original MAP message in cleartext is sent in step 4.b, or a MAPsec message with Protection Mode 0 is created in step 3.
 - c) If a valid SA exists and the MAP dialogue being handled requires protection, then the process continues at step 3.
3. NEa constructs the MAPsec message towards NEb using the parameters (keys, algorithms and protection profiles) found in the SA.
4. NEa generates either:
 - a) MAPsec message towards NEb.

- b) An unprotected MAP message in the event that the SPD towards NEb or protection profiles for that specific MAP dialogue so allows it (1.a. or 2.b.).

At the Receiving Entity, NEb performs the following actions during the inbound processing of every MAP message it received:

- 5. If an unprotected MAP message is received, the process continues with step 6.

Otherwise, NEb decomposes the received MAPsec message and retrieves basic information to apply security measures ('SPI', 'sending PLMN-ID', 'TVP', 'IV' and 'Original Component Identifier').

Freshness of the protected message is checked at this time. If the Time Variant Parameter (TVP) received in the protected message is out of the acceptable window then the message shall be discarded and an error is returned to MAP user. No error message is returned to NEa.

- 6. NEb checks the SPD:

An unprotected MAP message is received:

- a) If an unprotected MAP message is received and fallback to unprotected mode is allowed, then the unprotected MAP message is simply processed (Process goes to END)
- b) If an unprotected MAP message is received and the 'MAPsec operation components table' of the SPD does not mandate the use of MAPsec for the included 'Original Component Identifier', then the unprotected MAP message is simply processed (Process goes to END)
- c) If an unprotected MAP message is received, the 'MAPsec operation components table' of the SPD mandates the use of MAPsec for the included 'Original Component Identifier' and fallback to unprotected mode is NOT allowed, then the message is discarded.

If the MAP dialogue is still open and it is waiting for an answer, NEb also reports an error back to NEa.

A MAPsec message is received:

- d) If no valid entry in the SPD is found for PLMN A, then the message is discarded and an error is reported to MAP user.

If the MAP dialogue is still open and it is waiting for an answer, NEb also reports an error back to NEa.

- e) If a MAPsec message is received, but the SPD indicates that MAPsec is NOT to be used, then the message is discarded and an error is reported to MAP user.

If the MAP dialogue is still open and it is waiting for an answer, NEb also reports an error back to NEa.

- f) If a MAPsec message is received and the SPD indicates that MAPsec is required, then the process continues at step 7.

- 7. NEb checks its SAD to retrieve the relevant SA-information for processing of the MAPsec message:

- a) If the received SPI points to a valid SA, then the process continues at step 8.
- b) If the received SPI does not point to a valid SA, the message is discarded and an error is reported to MAP user. If the MAP dialogue is still open and it is waiting for an answer, NEb also reports an error back to NEa.

- 8. Integrity and encryption mechanisms are applied on the message using the information in the SA (Keys, algorithms, protection profiles).

- a) If the result after applying such mechanisms is NOT successful then the message is discarded and an error is reported to MAP user. If the MAP dialogue is still open and it is waiting for an answer, NEb also reports an error back to NEa.
- b) If the result after applying such procedures is successful, then NEb has the cleartext MAP message NEa originally wanted to send NEb. The cleartext MAP message can now be processed (Process goes to END)

END: A cleartext MAP message is available at NEb.

In the event the received message at NEb requires an answer to NEa (Return Result/Error), NEb will perform the process in steps 1 to 4 acting as the Sender and NEa will perform the process in steps 5 to 8 acting as the Receiver.

In the event a MAPsec enabled NE initiated a secured MAP communication towards a non-MAPsec enabled NE and the MAPsec enabled NE received an error indication of such circumstance (i.e. "ApplicationContextNotSupported"). The MAPsec enabled NE shall check whether "Fallback to Unprotected Mode" is allowed:

- If NOT allowed, then the communication is aborted.
- If allowed, then the MAPsec enabled NE shall send an unprotected MAP message instead.

The same procedures shall apply to secure MAP communications between MAP-NEs in the same PLMN.

NOTE: Because various error cases may be caused by active attacks, it is highly recommended that the cases are reported to the management system.

Annex **BC** (informative): Change history

Change history							
Date	TSG #	TSG Doc.	CR	Rev	Subject/Comment	Old	New
June 2001	SP_12	SP-010322			Presented to TSG SA #12 and approved (Release 4)	2.0.0	4.0.0
Sept 2001	SP_13	SP-010496	001		All messages of the same application context shall be applied MAPsec or not at all	4.0.0	4.1.0
Sept 2001	SP_13	SP-010497	002		Clarification of Scope	4.0.0	4.1.0
Sept 2001	SP_13	SP-010498	005	1	Clarifications in SPD and SAD contents	4.0.0	4.1.0
Sept 2001	SP_13	SP-010499	007		MAPsec Message Flow including extra SPD table	4.0.0	4.1.0
Sept 2001	SP_13	SP-010500	008	1	Correction to security policy requirements	4.0.0	4.1.0
Sept 2001	SP_13	SP-010501	009		Content and identifiers of a MAPSec SA	4.0.0	4.1.0
Sept 2001	SP_13	SP-010502	010		MIA key length unspecified	4.0.0	4.1.0
Sept 2001	SP_13	SP-010503	011		MAC calculation in PM2	4.0.0	4.1.0