

<b>CHANGE REQUEST</b>		Please see embedded help file at the bottom of this page for instructions on how to fill in this form correctly.	
<b>33.102 CR 104r1</b>		Current Version: <b>3.5.0</b>	
GSM (AA.BB) or 3G (AA.BBB) specification number ↑		↑ CR number as allocated by MCC support team	
For submission to: <b>SA#9</b>	for approval <input checked="" type="checkbox"/>	strategic <input type="checkbox"/>	(for SMG use only)
list expected approval meeting # here ↑	for information <input type="checkbox"/>	non-strategic <input type="checkbox"/>	

Form: CR cover sheet, version 2 for 3GPP and SMG The latest version of this form is available from: ftp://ftp.3gpp.org/Information/CR-Form-v2.doc

**Proposed change affects:** (U)SIM  ME  UTRAN / Radio  Core Network   
*(at least one should be marked with an X)*

**Source:** Siemens Atea **Date:** 6 Sept. 2000

**Subject:** Re-transmission of authentication request using the same quintet

**Work item:** Security

<b>Category:</b>	F Correction <input checked="" type="checkbox"/> A Corresponds to a correction in an earlier release <input type="checkbox"/> B Addition of feature <input type="checkbox"/> C Functional modification of feature <input type="checkbox"/> D Editorial modification <input type="checkbox"/>		<b>Release:</b>	Phase 2 <input type="checkbox"/> Release 96 <input type="checkbox"/> Release 97 <input type="checkbox"/> Release 98 <input type="checkbox"/> Release 99 <input checked="" type="checkbox"/> Release 00 <input type="checkbox"/>
------------------	--	--	-----------------	--

(only one category shall be marked with an X)

**Reason for change:** In GSM it occurs frequently that due to the loss of an authentication request or an authentication response, an VLR or SGSN has to re-transmit the authentication request.

The modifications proposed in this CR allow for the same re-transmission procedures in UMTS - where special measures are required to allow this re-transmissions, due to the verification of the freshness of the sequence number in the USIM.

The USIM keeps track of the last (RAND, AUTN) pair until START is updated.

**Clauses affected:** 6.3.3

<b>Other specs Affected:</b>	Other 3G core specifications <input checked="" type="checkbox"/> Other GSM core specifications <input type="checkbox"/> MS test specifications <input type="checkbox"/> BSS test specifications <input type="checkbox"/> O&M specifications <input type="checkbox"/>	→ List of CRs: TS 24.008 CR nnn → List of CRs: → List of CRs: → List of CRs: → List of CRs:
------------------------------	--	---

**Other comments:**



help.doc

<----- double-click here for help and instructions on how to create a CR.

### 6.3.3 Authentication and key agreement

The purpose of this procedure is to authenticate the user and establish a new pair of cipher and integrity keys between the VLR/SGSN and the USIM. During the authentication, the USIM verifies the freshness of the authentication vector that is used.

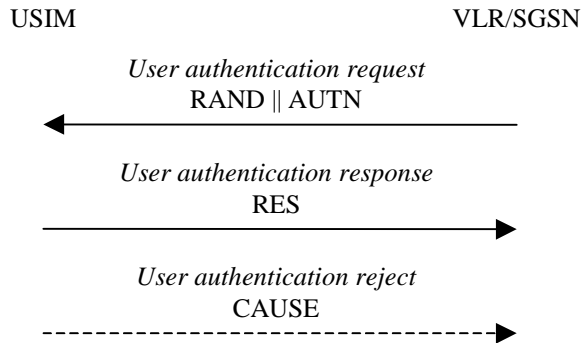

**Figure 8: Authentication and key establishment**

The VLR/SGSN invokes the procedure by selecting the next unused authentication vector from the ordered array of authentication vectors in the VLR/SGSN database. The VLR/SGSN sends to the USIM the random challenge RAND and an authentication token for network authentication AUTN from the selected authentication vector.

Upon receipt the user proceeds as shown in Figure 9.

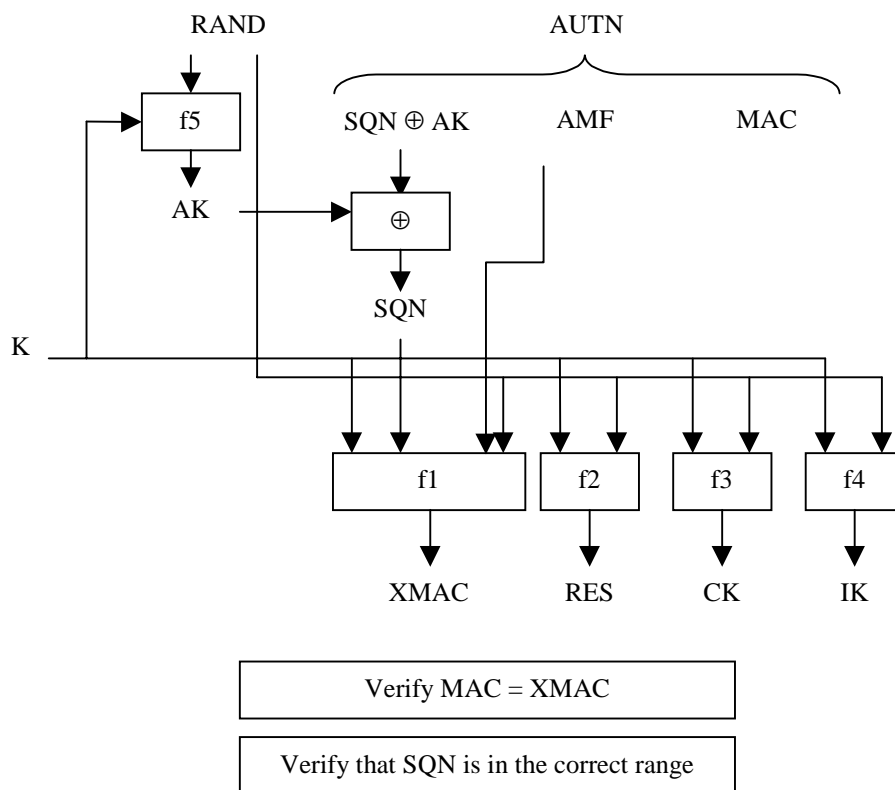

**Figure 9: User authentication function in the USIM**

Upon receipt of RAND and AUTN the USIM first computes the anonymity key  $AK = f5_K(RAND)$  and retrieves the sequence number  $SQN = (SQN \oplus AK) \oplus AK$ .

Next the USIM computes  $XMAC = f1_K (SQN \parallel RAND \parallel AMF)$  and compares this with MAC which is included in AUTN. If they are different, the user sends *user authentication reject* back to the VLR/SGSN with an indication of the cause and the user abandons the procedure. In this case, VLR/SGSN shall initiate an Authentication Failure Report procedure towards the HLR as specified in section 6.3.6. VLR/SGSN may also decide to initiate a new identification and authentication procedure towards the user.

Next the USIM verifies that the received sequence number SQN is in the correct range.

If the USIM considers the sequence number to be not in the correct range, it sends *synchronisation failure* back to the VLR/SGSN including an appropriate parameter, and abandons the procedure.

The synchronisation failure message contains the parameter AUTS. It is  $AUTS = Conc(SQN_{MS}) \parallel MAC-S$ .  $Conc(SQN_{MS}) = SQN_{MS} \oplus f5_K(MAC-S \parallel 0...0)$  is the concealed value of the counter  $SEQ_{MS}$  in the MS, and  $MAC-S = f1*_K(SEQ_{MS} \parallel RAND \parallel AMF)$  where RAND is the random value received in the current user authentication request.  $f1^*$  is a message authentication code (MAC) function with the property that no valuable information can be inferred from the function values of  $f1^*$  about those of  $f1, \dots, f5$  and vice versa.

The AMF used to calculate MAC-S assumes a dummy value of all zeros so that it does not need to be transmitted in the clear in the re-synch message.

The construction of the parameter AUTS is shown in the following Figure 10:

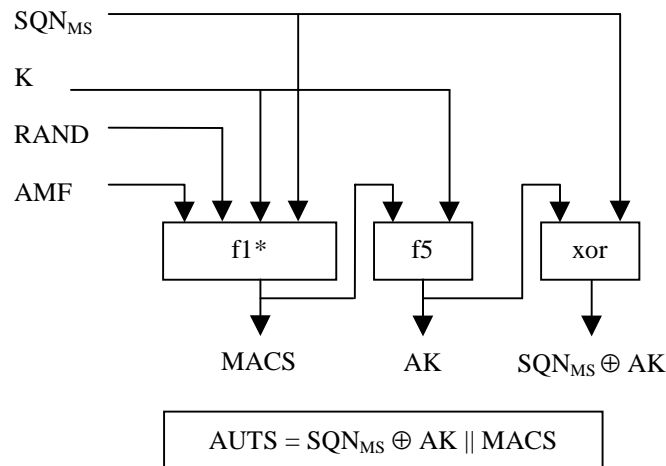

**Figure 10: Construction of the parameter AUTS**

If the sequence number is considered to be in the correct range however, the USIM computes  $RES = f2_K (RAND)$  and includes this parameter in a *user authentication response* back to the VLR/SGSN. Finally the USIM computes the cipher key  $CK = f3_K (RAND)$  and the integrity key  $IK = f4_K (RAND)$ . Note that if this is more efficient, RES, CK and IK could also be computed earlier at any time after receiving RAND. If the USIM also supports conversion function c3, it shall derive the GSM cipher key Kc from the UMTS cipher/integrity keys CK and IK. UMTS keys are sent to the MS along with the derived GSM key for UMTS-GSM interoperability purposes. USIM shall store original CK, IK until the next successful execution of AKA.

Upon receipt of *user authentication response* the VLR/SGSN compares RES with the expected response XRES from the selected authentication vector. If XRES equals RES then the authentication of the user has passed. The VLR/SGSN also selects the appropriate cipher key CK and integrity key IK from the selected authentication vector. If XRES and RES are different, VLR/SGSN shall initiate an Authentication Failure Report procedure towards the HLR as specified in section 6.3.6. VLR/SGSN may also decide to initiate a new identification and authentication procedure towards the user.

**Conditions on the use of authentication information by the VLR/SGSN:** The VLR/SGSN shall use a UMTS authentication vector (i.e. a quintuplet) only once and, hence, shall send out each user authentication request *RAND // AUTN* only once no matter whether the authentication attempt was successful or not. A consequence is that UMTS authentication vectors (quintuplets) cannot be reused.

#### Re-use and re-transmission of (RAND, AUTN)

The verification of the SQN by the USIM will cause the MS to reject an attempt by the VLR/SGSN to re-use a quintet

to establish a particular UMTS security context more than once. In general therefore the VLR/SGSN shall use a quintet only once.

There is one exception however: in the event that the VLR/SGSN has sent out an *authentication request* using a particular quintet and does not receive a response message (*authentication response* or *authentication reject*) from the MS, it may re-transmit the *authentication request* using the same quintet. However, as soon as a response message arrives no further re-transmissions are allowed. If after the initial transmission or after a series of re-transmissions no response arrives, retransmissions may be abandoned. If retransmissions are abandoned then the VLR/SGSN shall delete the quintet.

At the MS side, in order to allow this re-transmission without causing additional re-synchronisation procedures, the USIM shall store the last (RAND, AUTN) pair as well as the corresponding RES. When the USIM receives an *authentication request* and discovers that a (RAND, AUTN) pair is repeated and the associated START parameter is 0, it shall re-transmit the response. The USIM shall delete the stored (RAND, AUTN) pair and the corresponding RES as soon as the START parameter is updated by the ME (see section 6.4.8).