

# GSMA Requirements for 5G SA Roaming & Interconnect

Ahmad Muhanna, Mavenir

## LS to 3GPP on: Overall Description & Background

### GSMA requirements for intermediaries in roaming ecosystem (RH, IPX and RVAS)



- GSMA 5GMRR Task Force (2019) to evolve the current roaming ecosystem towards 5G SA roaming.
- 5G SA, **for the first time** in roaming, introduces an e2e service architecture with e2e security.
- 5G SA roaming solution impacts **current 2/3/4G hop-by-hop approach** used in roaming ecosystem.
- To enable a smooth transition to 5G SA roaming, 5GMRR believes in-depth considerations on the integration of existing **intermediaries and services** in roaming and interconnect are required.
- 5GMRR asks 3GPP to consider the entities currently exist in roaming ecosystem in 3GPP specs. Entities by their role: Roaming Hubs (RH), IPX providers, and Roaming Value-Added Service (RVAS).
  - Note: a single intermediary (a legal entity) can assume multiple roles.
- Services these three entities offer are detailed in LSs. (S3-231718, S3-231719, and S3-231720)
- These services are appreciated by operators for deploying and maintaining scalable roaming and interconnect across the globe. e.g., these entities may need access to messages exchanged between PLMNs to be able to offer their services.

## Existing 4G Roaming solution:

### What hop-by-hop roaming means to existing Intermediaries (RH, IPX, RVAS)

Hop-by-Hop approach enables the Intermediaries (RH, IPX, RVAS) with the following:

- Intermediary has full access to the message exchanged over roaming interfaces.
- Enables intermediary, e.g., RH, to terminate S8 at RH and establish another S8 with the HPLMN PSGW.
  - Intermediary, e.g., RH, has full control on Data session to enforce (legal contracted) QoS and Data volume quota per roaming PLMN.
  - Intermediary, e.g., RH, is able to terminate sessions to both VPLMN and HPLMN gracefully.
- Since **no e2e security**, intermediary is freely able to change the message content (within its legal contract) transparently from the other roaming partner, e.g., HPLMN.
- Intermediary, e.g., RH, is able to deploy its own mini-EPC, e.g., PSGW and possibly more.

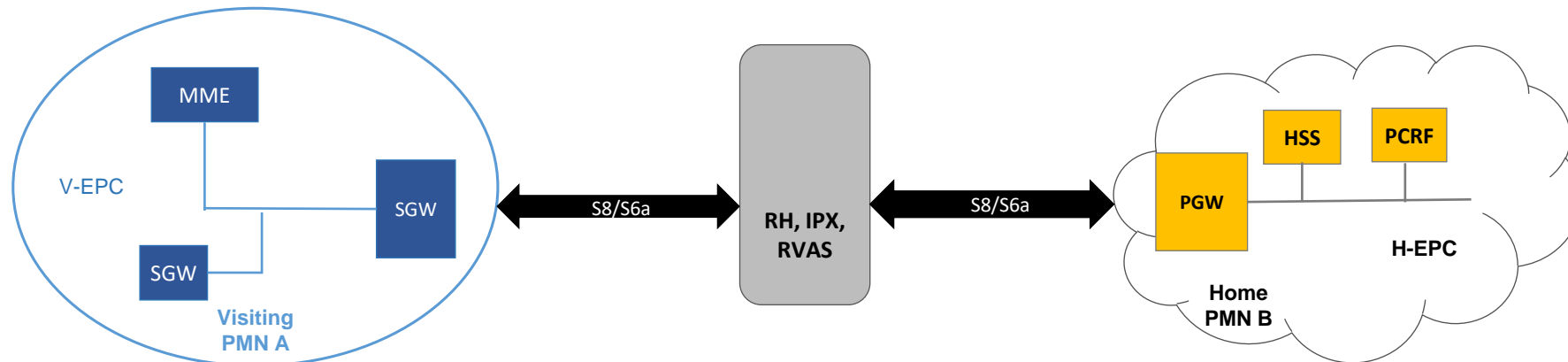

## 5G SA Roaming solution: PRINS impact on exiting Intermediaries (RH, IPX, RVAS)

### end-2-end PRINS impact on the current Roaming ecosystem Intermediaries (RH, IPX, RVAS):

- With Protection policy configured to NO encryption, Intermediary has full access to the message exchanged over N32 roaming interfaces.
- Currently, there is no mechanism to allow intermediary, e.g., RH, to control data session and thus, Intermediary can NOT fulfill its legal contract by enforcing QoS and Volume Quota per roaming partner.
- Since **security is e2e (PRINS)**, intermediary is NOT able to change the message content (despite legal contract) transparently from the other roaming partner, e.g., HPLMN.

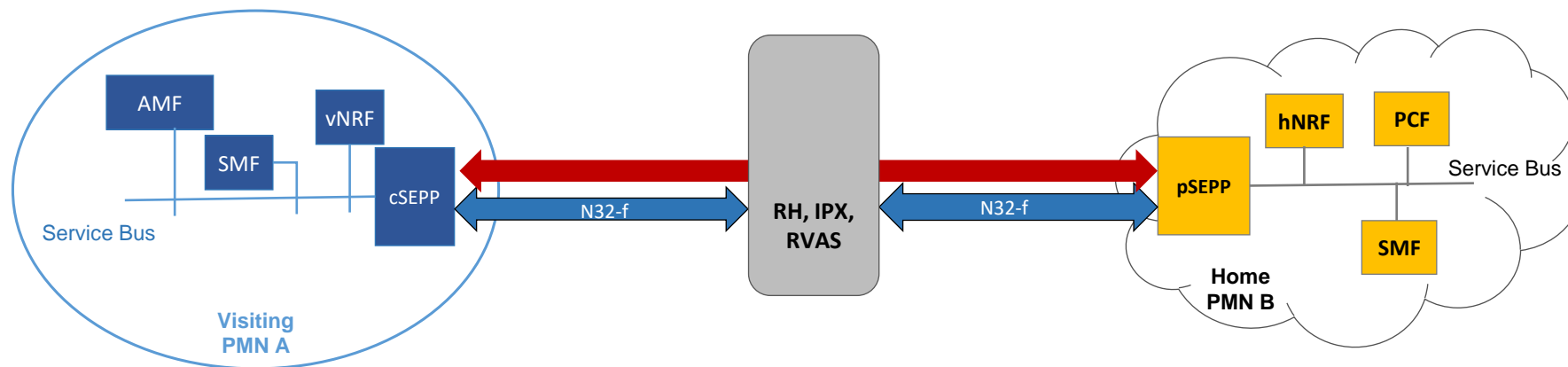

## Public Roaming Hub usecase: Description and Main Requirements

**RH Requirements:** No prior business communication between Visiting PMN-A and Home PMN-B

- Reject N32 connectivity and any CP traffic exchanged over N32 interface with Roaming partners on behalf of Client Operators
- To be perceived as a roaming partner for its Client Operators in a similar manner as RH providers are defined and working in the mobile roaming eco-system for 2G/3G and LTE.
  - NOTE: Provide the ability for RH to support any Client PLMN applicable privacy and security regulations, which may limit access to specific information not required for RH to fulfil its obligations or may mandate jurisdiction where services can be provided
- Adhere to same technical security guidelines as those applicable to MNO. FS.21 chapter 14 “Holistic Security approach for Mobile Roaming services” that need to be added as binding condition in the Roaming Hubbing Agreement Templates.
  - Only be able to modify, add or delete information that is relevant to their role, respecting what is contractually agreed in service level agreements (SLAs) and service level objectives (SLOs) and enforced technically.

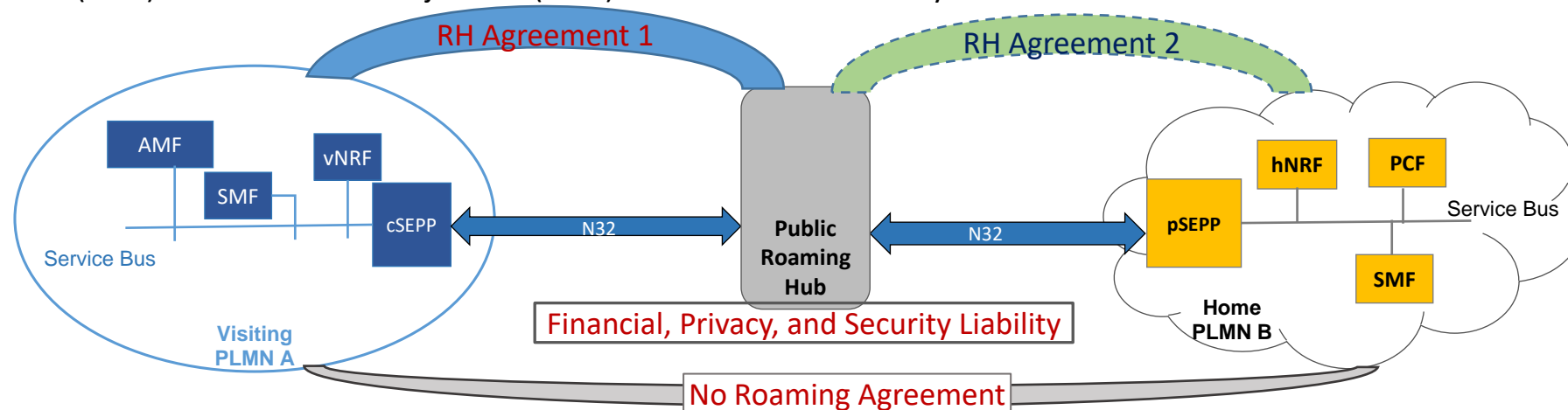

## GSMA Intermediaries Requirements impact on 5G SA: Assuming GSMA would like hop-by-hop approach

- After 3+ years of discussion in GSMA, GSMA stakeholders are NOT against PRINS but against any end-to-end security solution.
- Currently, an end-to-end security solution limits the ability of GSMA intermediaries, RH, IPX, and RVAS, to function as freely as they would like to do in similar ways as in 4G roaming.
- It is fair to consider that GSMA is after a hop-by-hop solution where the intermediary has full access and ability to control, and transparently able to modify, add, delete content of message (within its contractual agreement).
- It is obvious that 3GPP 5G SA architecture has not taken hop-by-hop approach in its 5G SA roaming architecture consideration.
- Can GSMA stakeholders make current 5GS architecture work using a hop-by-hop approach as in 4G, **Personally**, I believe they can. However, GSMA stakeholders **will be much happier** if hop-by-hop approach is standardized in 3GPP specifications.
- If 3GPP agrees to hop-by-hop approach, **Personally** SA3 should make sure that most secure hop-by-hop solution is adopted.
- SA3 should ensure that adopted hop-by-hop solution can evolve to deliver end-to-end security in the future; **if regulation require**

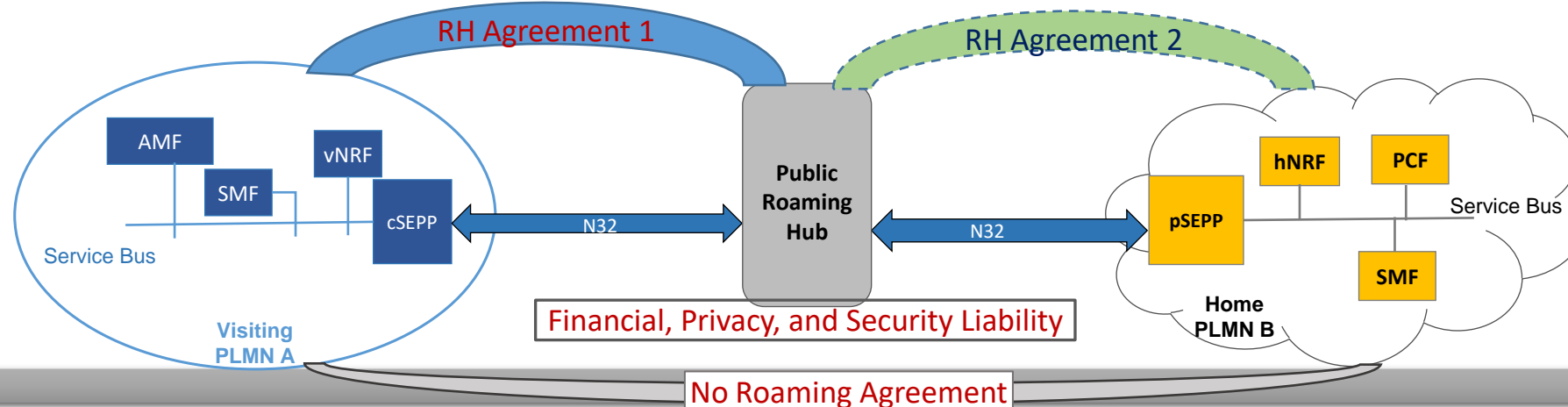

# GSMA Intermediaries Requirements Architectural impact on 5G SA: Assuming GSMA would like hop-by-hop approach

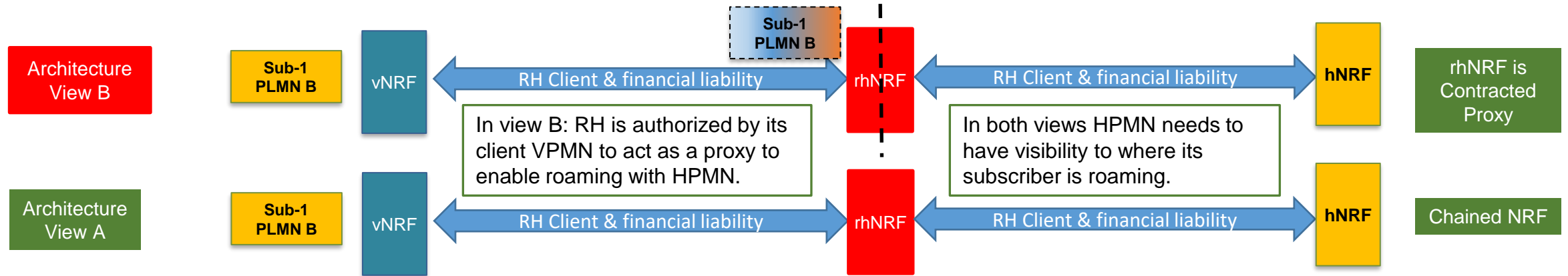

- 1. **View A:** is not supported by 3GPP 5G SA
- 2. **View B:** It can be made to work w/o 3GPP change(s)
- 3. **Option B:** RH providers prefer clear indication in 3GPP standard

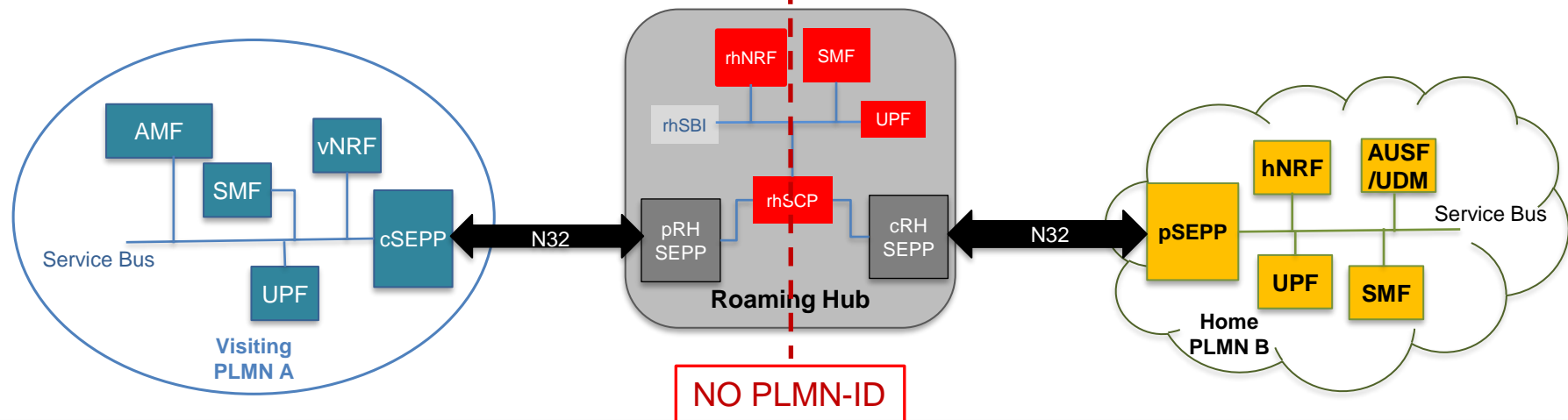

# SA2 Feedback Requirement:

## Assuming GSMA would like hop-by-hop approach

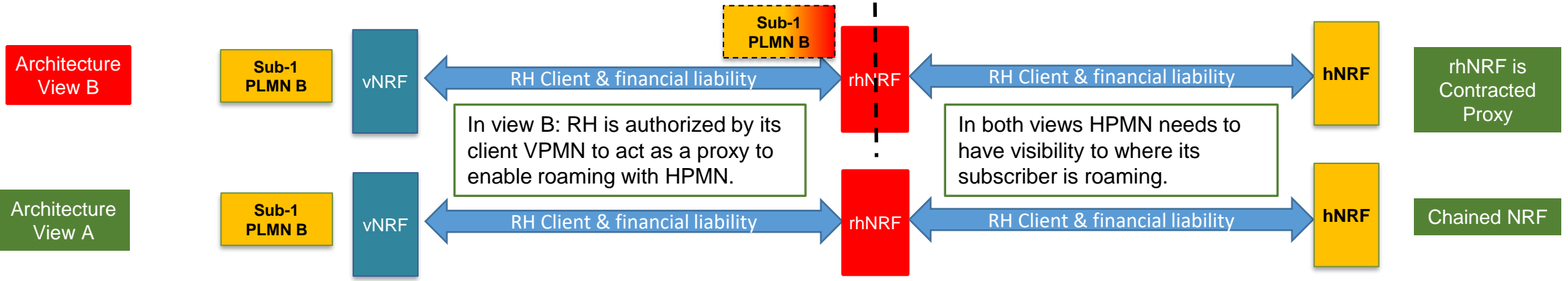

- View A:** It is obvious that SA2 consideration & Feedback is needed.
- View B:** It is recommended that SA2 evaluate this option and provide impact on 5G SA architecture.

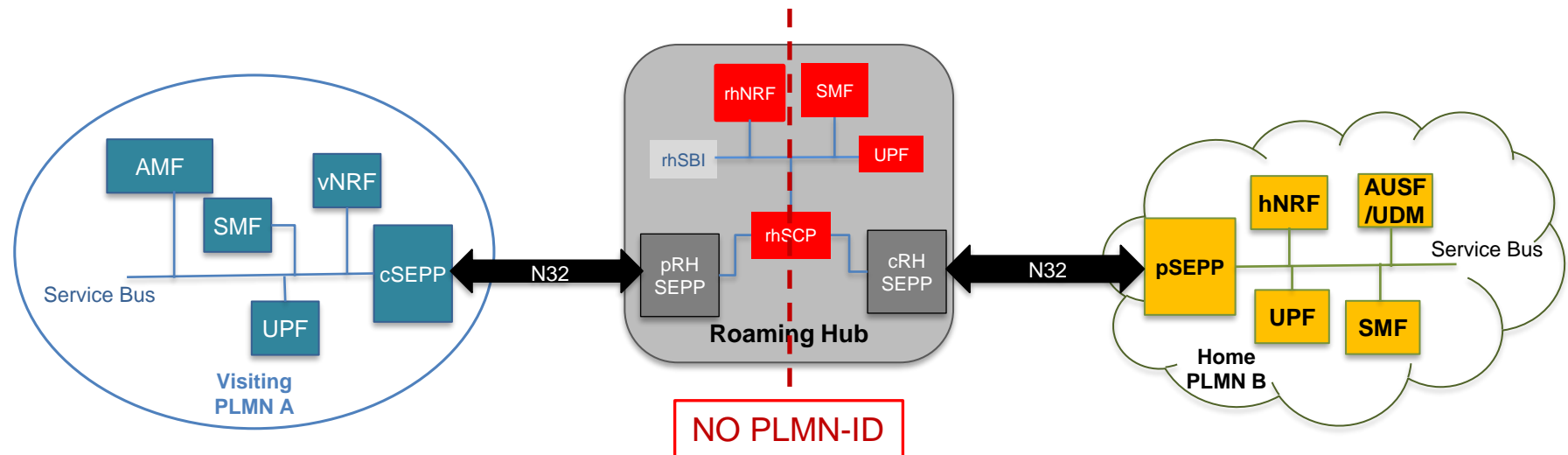



# Backup