

Technical Specification Group Services and System Aspects **TSGS#12(01)0371**

Meeting #12, Stockholm, Sweden, 18-21 June 2001

Source: TSG SA WG2
Title: CRs on 03.71, 23.171 and 23.271
Agenda Item: 7.2.3

REVISION OF TDOC SP-010334

The following Change Requests (CRs) have been approved by TSG SA WG2 and are requested to be approved by TSG SA plenary #12.

Note: the source of all these CRs is now S2, even if the name of the originating company(ies) is still reflected on the cover page of all the attached CRs.

The CR category shown here supersedes the one mentioned in the CR cover page.

On 03.71:

CR#	rev	Rel	title	cat	in ver	out ver	S2#	WI
A025	1	R98	Correct reference of GAD shape	DF	7.5.0	7.6.0	S2-011500	LCS
A026	1	R99	Correct reference of GAD shape	DA	8.1.0	8.2.0	S2-011501	LCS
A027	1	R98	Privacy Check procedures for call related MT-LR	F	7.5.0	7.6.0	S2-011502	LCS
A028	1	R99	Privacy Check procedures for call related MT-LR	A	8.1.0	8.2.0	S2-011503	LCS
A023 Rev2	3	R98	Correction of Inconsistent Text	F	7.5.0	7.6.0	S2-011513rev1	LCS
A024 Rev2	3	R99	Correction of Inconsistent Text	A	8.1.0	8.2.0	S2-011514rev1	LCS

Note: the content of CR A023 and A024 was revised during SA#12.

On 23.171:

CR#	rev	Rel	title	cat	in ver	out ver	S2#	WI
018 Rev1	1	R99	LCS location notification messages	DF	3.3.0	3.4.0	S2-011504	LCS

On 23.271:

CR#	rev	Rel	title	cat	in ver	out ver	S2#	WI
024		R4	Applicability of LCS services in CS domain to GPRS mobile stations	AF	4.1.0	4.2.0	S2-011507	LCS1
022 Rev2	2	R4	Alignment of 23.271 with GERAN LCS stage 2, TS 43.059	EF	4.1.0	4.2.0	S2-011509	LCS1
023 Rev1	1	R4	Completion of changes regarding UE LCS capabilities	DF	4.1.0	4.2.0	S2-011510	LCS1
026 Rev4	4	R4	Re-attempt of location request when MS becomes reachable	BF	4.1.0	4.2.0	S2-011511	LCS1

Explanations on CRs against 23.271:

CR 024: The corresponding modification to R99 was in 23.171 (approved in March). But as it concerns a different TS, the category should be "F" and not "A".

CR 022r2: It removes Stage 2 of LCS support in GERAN for Rel4. Alignment of TSs, so should be cat. "F".

CR 023r1: It corrects some inconsistencies introduced by an earlier CR, so it should be "F".

CR 026r4: Alignment of the Stage 2 with the Stages 1 and 3. The Stage 3 CR has just been approved at TSG CN#12 (CR#268 on 29.002, tdoc NP-010347). So it should be "F".

CR-Form-v3

CHANGE REQUEST

⌘ **03.71 CR A025** ⌘ rev **1** ⌘ Current version: **7.5.0** ⌘

For **HELP** on using this form, see bottom of this page or look at the pop-up text over the ⌘ symbols.

Proposed change affects: ⌘ (U)SIM ME/UE Radio Access Network Core Network

Title:	⌘ Correct reference of GAD shape		
Source:	⌘ Ericsson		
Work item code:	⌘ LCS	Date:	⌘ 2001-Apr-21
Category:	⌘ F	Release:	⌘ R98
	<i>Use one of the following categories:</i> F (essential correction) A (corresponds to a correction in an earlier release) B (Addition of feature), C (Functional modification of feature) D (Editorial modification) Detailed explanations of the above categories can be found in 3GPP TR 21.900.		<i>Use one of the following releases:</i> 2 (GSM Phase 2) R96 (Release 1996) R97 (Release 1997) R98 (Release 1998) R99 (Release 1999) REL-4 (Release 4) REL-5 (Release 5)

Reason for change:	⌘ "Ellipsoid point with uncertainty circle and confidence" is not defined in GSM TS 03.32; "Ellipsoid point with uncertainty circle" is the correct shape name to be referenced.
Summary of change:	⌘ The reference to "Ellipsoid point with uncertainty circle and confidence" is replaced with the reference to "Ellipsoid point with uncertainty circle"
Consequences if not approved:	⌘ A reference to a not defined shape is given in the document.

Clauses affected:	⌘ 7.6.1.2, 7.6.6.3	
Other specs affected:	⌘ <input type="checkbox"/> Other core specifications <input type="checkbox"/> Test specifications <input type="checkbox"/> O&M Specifications	⌘
Other comments:	⌘	

How to create CRs using this form:

Comprehensive information and tips about how to create CRs can be found at: http://www.3gpp.org/3G_Specs/CRs.htm. Below is a brief summary:

- 1) Fill out the above form. The symbols above marked ⌘ contain pop-up help information about the field that they are closest to.
- 2) Obtain the latest version for the release of the specification to which the change is proposed. Use the MS Word "revision marks" feature (also known as "track changes") when making the changes. All 3GPP specifications can be downloaded from the 3GPP server under <ftp://www.3gpp.org/specs/> For the latest version, look for the directory name with the latest date e.g. 2000-09 contains the specifications resulting from the September 2000 TSG meetings.
- 3) With "track changes" disabled, paste the entire CR form (use CTRL-A to select it) into the specification just in front of the clause containing the first piece of changed text. Delete those parts of the specification which are not relevant to the change request

7.6.1.2 Positioning Measurement Establishment Procedure

- 11) If the requested location information and the location accuracy within the QoS can be satisfied by the reported cell ID and, if available, TA value, the SMLC may send a MAP_PERFORM_LOCATION ack. immediately. Otherwise, the SMLC determines the positioning method and instigates the particular message sequence for this method defined in subsequent sections. If the position method returns position measurements, the SMLC uses them to compute a location estimate. If there has been a failure to obtain position measurements, the SMLC may use the current cell ID and, if available, TA value to derive an approximate location estimate. If an already computed location estimate is returned for an MS based position method, the SMLC may verify consistency with the current cell ID and, if available, TA value. If the location estimate so obtained does not satisfy the requested accuracy or the location attempt failed, e.g. due to missing data, and sufficient response time still remains, the SMLC may instigate a further location attempt using the same (e.g. providing more assistance data to MS) or a different position method. If a vertical location coordinate is requested but the SMLC can only obtain horizontal coordinates, these may be returned.

Restrictions on the geographic shape encoded within the “position information” parameter may exist for certain LCS client types. The SMLC shall comply with any restrictions defined in GSM and, in a particular country, with any restrictions defined for a specific LCS client type in relevant national standards. For example, in the US, national interim standard TIA/EIA/IS-J-STD-036 restricts the geographic shape for an emergency services LCS client to minimally either an “ellipsoid point” or an “ellipsoid point with uncertainty circle” and ~~confidence~~ as defined in GSM TS 03.32.

*** NEXT MODIFIED SECTION ***

7.6.6.3 Location Calculation and Release Procedure

- 9) When a location estimate best satisfying the requested QoS has been obtained or when the requested location assistance data has been transferred to the MS, the SMLC returns a BSSMAP-LE Perform Location response to the VMSC if the SMLC is NSS based. This message carries the location estimate or ciphering keys if this was obtained. If a location estimate or deciphering keys were not successfully obtained or if the requested location assistance data could not be transferred successfully to the MS, a failure cause is included in the Perform Location response.

Restrictions on the geographic shape encoded within the “position information” parameter may exist for certain LCS client types. The SMLC shall comply with any restrictions defined in GSM and, in a particular country, with any restrictions defined for a specific LCS client type in relevant national standards. For example, in the US, national interim standard TIA/EIA/IS-J-STD-036 restricts the geographic shape for an emergency services LCS client to minimally either an “ellipsoid point” or an “ellipsoid point with uncertainty circle” and ~~confidence~~ as defined in GSM TS 03.32.

- 10) For a BSS based SMLC, the BSSMAP-LE Perform Location response is instead returned to the serving BSC.
- 11) In the case of a BSS based SMLC, the BSC forwards the BSSMAP PERFORM LOCATION response received in step 10 to the VMSC.
- 12) If the MS requested transfer of its location to another LCS client and a location estimate was successfully obtained, the VMSC shall send a MAP Subscriber Location Report to the GMLC obtained in step 4 carrying the MSISDN of the MS, the identity of the LCS client, the event causing the location estimate (MO-LR) and the location estimate and its age.
- 13) The GMLC shall acknowledge receipt of the location estimate provided that it serves the identified LCS client and the client is accessible.
- 14) The GMLC transfers the location information to the LCS client either immediately or upon request from the client.

- 15) The VMSC returns a DTAP LCS MO-LR Return Result to the MS carrying any location estimate requested by the MS, ciphering keys or a confirmation that a location estimate was successfully transferred to the GMLC serving an LCS client.
- 16) The VMSC may release the CM, MM and RR connections to the MS, if the MS was previously idle, and the VMSC may record billing information.

CHANGE REQUEST

⌘ **03.71 CR A026** ⌘ rev **1** ⌘ Current version: **8.1.0** ⌘

For **HELP** on using this form, see bottom of this page or look at the pop-up text over the ⌘ symbols.

Proposed change affects: ⌘ (U)SIM ME/UE Radio Access Network Core Network

Title:	⌘ Correct reference of GAD shape		
Source:	⌘ Ericsson		
Work item code:	⌘ LCS	Date:	⌘ 2001-Apr-21
Category:	⌘ A	Release:	⌘ R99
	<i>Use one of the following categories:</i> F (essential correction) A (corresponds to a correction in an earlier release) B (Addition of feature), C (Functional modification of feature) D (Editorial modification) Detailed explanations of the above categories can be found in 3GPP TR 21.900.		<i>Use one of the following releases:</i> 2 (GSM Phase 2) R96 (Release 1996) R97 (Release 1997) R98 (Release 1998) R99 (Release 1999) REL-4 (Release 4) REL-5 (Release 5)

Reason for change:	⌘ "Ellipsoid point with uncertainty circle and confidence" is not defined in GSM TS 03.32; "Ellipsoid point with uncertainty circle" is the correct shape name to be referenced.
Summary of change:	⌘ The reference to "Ellipsoid point with uncertainty circle and confidence" is replaced with the reference to "Ellipsoid point with uncertainty circle"
Consequences if not approved:	⌘ A reference to a not defined shape is given in the document.

Clauses affected:	⌘ 7.6.1.2, 7.6.6.3	
Other specs affected:	⌘ <input type="checkbox"/> Other core specifications <input type="checkbox"/> Test specifications <input type="checkbox"/> O&M Specifications	⌘
Other comments:	⌘	

How to create CRs using this form:

Comprehensive information and tips about how to create CRs can be found at: http://www.3gpp.org/3G_Specs/CRs.htm. Below is a brief summary:

- 1) Fill out the above form. The symbols above marked ⌘ contain pop-up help information about the field that they are closest to.
- 2) Obtain the latest version for the release of the specification to which the change is proposed. Use the MS Word "revision marks" feature (also known as "track changes") when making the changes. All 3GPP specifications can be downloaded from the 3GPP server under <ftp://www.3gpp.org/specs/>. For the latest version, look for the directory name with the latest date e.g. 2000-09 contains the specifications resulting from the September 2000 TSG meetings.
- 3) With "track changes" disabled, paste the entire CR form (use CTRL-A to select it) into the specification just in front of the clause containing the first piece of changed text. Delete those parts of the specification which are not relevant to the change request

7.6.1.2 Positioning Measurement Establishment Procedure

- 11) If the requested location information and the location accuracy within the QoS can be satisfied by the reported cell ID and, if available, TA value, the SMLC may send a MAP_PERFORM_LOCATION ack. immediately. Otherwise, the SMLC determines the positioning method and instigates the particular message sequence for this method defined in subsequent sections. If the position method returns position measurements, the SMLC uses them to compute a location estimate. If there has been a failure to obtain position measurements, the SMLC may use the current cell ID and, if available, TA value to derive an approximate location estimate. If an already computed location estimate is returned for an MS based position method, the SMLC may verify consistency with the current cell ID and, if available, TA value. If the location estimate so obtained does not satisfy the requested accuracy or the location attempt failed, e.g. due to missing data, and sufficient response time still remains, the SMLC may instigate a further location attempt using the same (e.g. providing more assistance data to MS) or a different position method. If a vertical location coordinate is requested but the SMLC can only obtain horizontal coordinates, these may be returned.

Restrictions on the geographic shape encoded within the “position information” parameter may exist for certain LCS client types. The SMLC shall comply with any restrictions defined in GSM and, in a particular country, with any restrictions defined for a specific LCS client type in relevant national standards. For example, in the US, national interim standard TIA/EIA/IS-J-STD-036 restricts the geographic shape for an emergency services LCS client to minimally either an “ellipsoid point” or an “ellipsoid point with uncertainty circle” and confidence” as defined in 3GPP TS 23.032.

*** NEXT MODIFIED SECTION ***

7.6.6.3 Location Calculation and Release Procedure

- 9) When a location estimate best satisfying the requested QoS has been obtained or when the requested location assistance data has been transferred to the MS, the SMLC returns a BSSMAP-LE Perform Location response to the VMSC if the SMLC is NSS based. This message carries the location estimate or ciphering keys if this was obtained. If a location estimate or deciphering keys were not successfully obtained or if the requested location assistance data could not be transferred successfully to the MS, a failure cause is included in the Perform Location response.

Restrictions on the geographic shape encoded within the “position information” parameter may exist for certain LCS client types. The SMLC shall comply with any restrictions defined in GSM and, in a particular country, with any restrictions defined for a specific LCS client type in relevant national standards. For example, in the US, national interim standard TIA/EIA/IS-J-STD-036 restricts the geographic shape for an emergency services LCS client to minimally either an “ellipsoid point” or an “ellipsoid point with uncertainty circle” and confidence” as defined in 3GPP TS 23.032.

- 10) For a BSS based SMLC, the BSSMAP-LE Perform Location response is instead returned to the serving BSC.
- 11) In the case of a BSS based SMLC, the BSC forwards the BSSMAP PERFORM LOCATION response received in step 10 to the VMSC.
- 12) If the MS requested transfer of its location to another LCS client and a location estimate was successfully obtained, the VMSC shall send a MAP Subscriber Location Report to the GMLC obtained in step 4 carrying the MSISDN of the MS, the identity of the LCS client, the event causing the location estimate (MO-LR) and the location estimate and its age.
- 13) The GMLC shall acknowledge receipt of the location estimate provided that it serves the identified LCS client and the client is accessible.
- 14) The GMLC transfers the location information to the LCS client either immediately or upon request from the client.

- 15) The VMSC returns a DTAP LCS MO-LR Return Result to the MS carrying any location estimate requested by the MS, ciphering keys or a confirmation that a location estimate was successfully transferred to the GMLC serving an LCS client.
- 16) The VMSC may release the CM, MM and RR connections to the MS, if the MS was previously idle, and the VMSC may record billing information.

CHANGE REQUEST

⌘ **03.71 CR A027** ⌘ rev **1** ⌘ Current version: **7.5.0** ⌘

For **HELP** on using this form, see bottom of this page or look at the pop-up text over the ⌘ symbols.

Proposed change affects: ⌘ (U)SIM ME/UE Radio Access Network Core Network

Title:	⌘ Privacy Check procedures for Call Related MT-LR		
Source:	⌘ Ericsson		
Work item code:	⌘ LCS	Date:	⌘ 2001-Apr-21
Category:	⌘ F	Release:	⌘ R98
	<i>Use one of the following categories:</i> F (essential correction) A (corresponds to a correction in an earlier release) B (Addition of feature), C (Functional modification of feature) D (Editorial modification) Detailed explanations of the above categories can be found in 3GPP TR 21.900.		<i>Use one of the following releases:</i> 2 (GSM Phase 2) R96 (Release 1996) R97 (Release 1997) R98 (Release 1998) R99 (Release 1999) REL-4 (Release 4) REL-5 (Release 5)

Reason for change:	⌘ The privacy checks for a Call related MT-LR cannot be performed in cases of IN rerouting (i.e. LCS client reached via IN). The scope of this document is to align the Annex of the TS to chapters 7.12.3, 12.3.
Summary of change:	⌘ The call related MT-LR privacy check is always performed upon the number dialed by the MS and the called party number (call-related identity) sent by the GMLC can also be an E.164 number not in "international" format. It is up to the GMLC to use the valid national specific number in case of toll free number or abbreviated number routing when positioning an MS in the visited country.
Consequences if not approved:	⌘ The call related MT-LR privacy checks would always fail in case the LCS client is reached via IN rerouting. The annex would not be aligned to chapters 7.12.3, 12.3.

Clauses affected:	⌘ A.3
Other specs affected:	⌘ <input type="checkbox"/> Other core specifications ⌘ <input type="checkbox"/> <input type="checkbox"/> Test specifications <input type="checkbox"/> O&M Specifications
Other comments:	⌘

How to create CRs using this form:

Comprehensive information and tips about how to create CRs can be found at: http://www.3gpp.org/3G_Specs/CRs.htm. Below is a brief summary:

- 1) Fill out the above form. The symbols above marked ⌘ contain pop-up help information about the field that they are closest to.
- 2) Obtain the latest version for the release of the specification to which the change is proposed. Use the MS Word "revision marks" feature (also known as "track changes") when making the changes. All 3GPP specifications can be

downloaded from the 3GPP server under <ftp://www.3gpp.org/specs/> For the latest version, look for the directory name with the latest date e.g. 2000-09 contains the specifications resulting from the September 2000 TSG meetings.

- 3) With "track changes" disabled, paste the entire CR form (use CTRL-A to select it) into the specification just in front of the clause containing the first piece of changed text. Delete those parts of the specification which are not relevant to the change request.

A.3 Call Related MT-LR

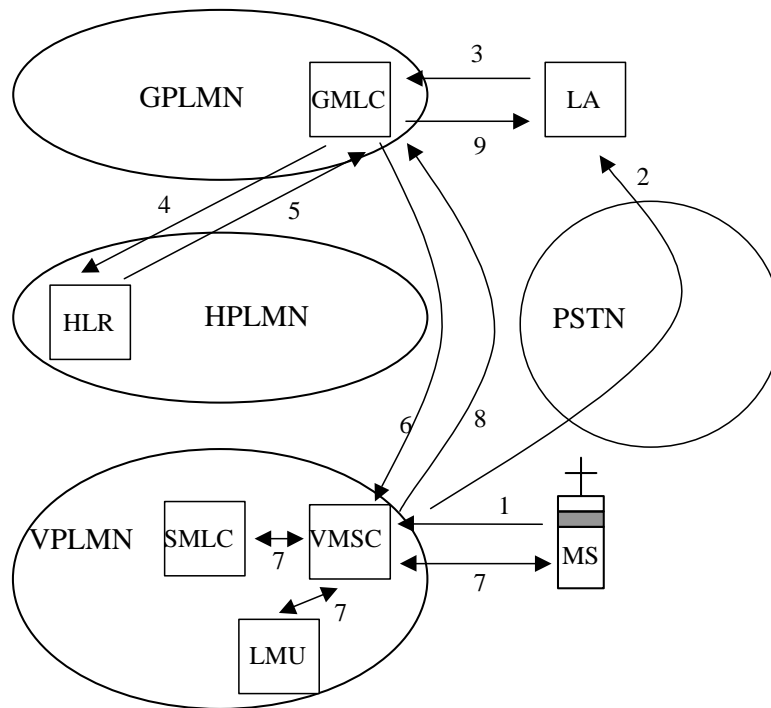

Figure A.2: Call Related MT-LR

1. An MS requests a voice or data call to some external Location Application (LA).
2. The call is routed from the VMSC through the PSTN to the LA. The MSC stores the original dialed number, and the PSTN or PSPDN number that was used to route the call if different.
3. The external LA obtains the MSISDN of the calling MS – either verbally or using calling line ID presentation. The LA may also need to verify the number dialed by the MS – e.g. if the LA can be reached by any of several dialed numbers. The external LA sends a Location Request to a GMLC in its serving GPLMN requesting the location of the MS and providing both the MSISDN and its own PSTN PSPDN the number as used dialed by the MS.
4. The GMLC queries the HLR of the MS to be located by sending a MAP query to the HPLMN of this MS. In order to route the query to the HLR, translation of the MSISDN of the MS to be located will be required. This translation may be performed within the GMLC and/or may be performed by intermediate STPs.
5. The HLR returns the E.164 address of the VMSC currently serving the MS in the VPLMN.
6. The GMLC forwards the location request to the VMSC and includes within it the PSTN or PSPDN number of the LA dialed by the MS. In order to route the request to the VMSC, translation of the E.164 address of the VMSC will be required. This translation may be performed within the GMLC and/or may be performed by intermediate STPs.
7. The VMSC verifies that the MS allows a call related MT-LR in its privacy exception list, that it currently has an originated call established and that the LA PSTN or PSPDN number supplied by the GMLC matches the number either dialed by the MS, or used to route the call. The VMSC then interacts with an SMLC and possibly one or more LMUs in the VPLMN to perform positioning of the MS.
8. The resulting location estimate is returned by the VMSC to the GMLC. The VMSC uses the E.164 address or SS7 signaling point code of the GMLC, provided in step 4, to correctly route the location estimate to the GMLC in the GPLMN.
9. The GMLC returns the location estimate to the requesting LA.

CR-Form-v3

CHANGE REQUEST

⌘ **03.71 CR A028** ⌘ rev **1** ⌘ Current version: **8.1.0** ⌘

For **HELP** on using this form, see bottom of this page or look at the pop-up text over the ⌘ symbols.

Proposed change affects: ⌘ (U)SIM ME/UE Radio Access Network Core Network

Title:	⌘ Privacy Check procedures for Call Related MT-LR		
Source:	⌘ Ericsson		
Work item code:	⌘ LCS	Date:	⌘ 2001-Apr-21
Category:	⌘ A	Release:	⌘ R99
	<p>Use <u>one</u> of the following categories:</p> <p>F (essential correction)</p> <p>A (corresponds to a correction in an earlier release)</p> <p>B (Addition of feature),</p> <p>C (Functional modification of feature)</p> <p>D (Editorial modification)</p> <p>Detailed explanations of the above categories can be found in 3GPP TR 21.900.</p>		<p>Use <u>one</u> of the following releases:</p> <p>2 (GSM Phase 2)</p> <p>R96 (Release 1996)</p> <p>R97 (Release 1997)</p> <p>R98 (Release 1998)</p> <p>R99 (Release 1999)</p> <p>REL-4 (Release 4)</p> <p>REL-5 (Release 5)</p>

Reason for change:	⌘ The privacy checks for a Call related MT-LR cannot be performed in cases of IN rerouting (i.e. LCS client reached via IN). The scope of this CR is to align the R99 to the requirement changes already approved for R98 (and rel 4).
Summary of change:	⌘ The call related MT-LR privacy check is always performed upon the number dialed by the MS and the called party number (call-related identity) sent by the GMLC can also be an E.164 number not in "international" format. It is up to the GMLC to use the valid national specific number in case of toll free number or abbreviated number routing when positioning an MS in the visited country.
Consequences if not approved:	⌘ The call related MT-LR privacy checks would always fail in case the LCS client is reached via IN rerouting.

Clauses affected:	⌘ 7.12.3, 12.3, A.3												
Other specs affected:	<table style="border: none;"> <tr> <td style="border: none;">⌘ <input type="checkbox"/></td> <td style="border: none;">Other core specifications</td> <td style="border: none;">⌘</td> <td style="border: none;"></td> </tr> <tr> <td style="border: none;">⌘ <input type="checkbox"/></td> <td style="border: none;">Test specifications</td> <td style="border: none;">⌘</td> <td style="border: none;"></td> </tr> <tr> <td style="border: none;">⌘ <input type="checkbox"/></td> <td style="border: none;">O&M Specifications</td> <td style="border: none;">⌘</td> <td style="border: none;"></td> </tr> </table>	⌘ <input type="checkbox"/>	Other core specifications	⌘		⌘ <input type="checkbox"/>	Test specifications	⌘		⌘ <input type="checkbox"/>	O&M Specifications	⌘	
⌘ <input type="checkbox"/>	Other core specifications	⌘											
⌘ <input type="checkbox"/>	Test specifications	⌘											
⌘ <input type="checkbox"/>	O&M Specifications	⌘											
Other comments:	⌘												

How to create CRs using this form:

Comprehensive information and tips about how to create CRs can be found at: http://www.3gpp.org/3G_Specs/CRs.htm. Below is a brief summary:

- 1) Fill out the above form. The symbols above marked ⌘ contain pop-up help information about the field that they are closest to.
- 2) Obtain the latest version for the release of the specification to which the change is proposed. Use the MS Word "revision marks" feature (also known as "track changes") when making the changes. All 3GPP specifications can be downloaded from the 3GPP server under <ftp://www.3gpp.org/specs/> For the latest version, look for the directory name with the latest date e.g. 2000-09 contains the specifications resulting from the September 2000 TSG meetings.

- 3) With "track changes" disabled, paste the entire CR form (use CTRL-A to select it) into the specification just in front of the clause containing the first piece of changed text. Delete those parts of the specification which are not relevant to the change request.

7.12.3 MS Privacy Options

The MS privacy options in the SLPP apply to an MT-LR or NI-LR and either indicate that no MT-LR or NI-LR is allowed for the MS (except as may be overridden by the POI or local regulatory requirements) or define the particular classes of LCS client for which an MT-LR or NI-LR for location are allowed, with the following classes being possible:

- a) Universal Class – allow positioning by all LCS clients
- b) Call related Class – comprises any LCS client to which the MS originated a call that is currently established. For all clients in the call related class, one of the following subscription options shall apply:
 - positioning allowed without notifying the MS user (default case);
 - positioning allowed with notification to the MS user;
 - positioning requires notification and verification by the MS user; positioning is allowed only if granted by the MS user or if there is no response to the notification;
 - positioning requires notification and verification by the MS user; positioning is allowed only if granted by the MS user;
- c) Non-Call related Class – allow positioning by specific identified LCS Clients or groups of LCS Client with the following restrictions allowed for each identified LCS Client or group of LCS Clients
 - Location request allowed only from GMLCs identified in the SLPP
 - Location request allowed only from a GMLC in the home country
 - Location request allowed from any GMLC

For each identified value added LCS client in the privacy exception list one of the following subscription options shall apply:

- positioning allowed without notifying the MS user (default case);
- positioning allowed with notification to the MS user;
- positioning requires notification and verification by the MS user; positioning is allowed only if granted by the MS user or if there is no response to the notification;
- positioning requires notification and verification by the MS user; positioning is allowed only if granted by the MS user;

For all value added LCS clients sending a non-call related MT-LR that are not identified in the privacy exception list, one of the following subscription option shall apply:

- positioning not allowed (default case);
 - positioning allowed with notification to the MS user;
 - positioning requires notification and verification by the MS user; positioning is allowed only if granted by the MS user or if there is no response to the notification;
 - positioning requires notification and verification by the MS user; positioning is allowed only if granted by the MS user;
- d) PLMN operator Class – allow positioning by specific types of client within or associated with the VPLMN, with the following types of client identified:
 - clients providing a location related broadcast service
 - O&M client in the HPLMN (when the MS is currently being served by the HPLMN)
 - O&M client in the VPLMN
 - Clients recording anonymous location information without any MS identifier

- Clients enhancing or supporting any supplementary service, IN service, bearer service or teleservice subscribed to by the target MS subscriber

If the MS subscribes to the universal class, any MT-LR or NI-LR shall be allowed by the VMSC. If local regulatory requirements mandate it, any MT-LR for an emergency services LCS client and any NI-LR for an emergency services call origination shall be allowed by the VMSC.

If the MS subscribes to the call-related class, an MT-LR may be allowed if the MS previously originated a call that is still established and the called party number either dialed by the MS or used by the VMSC for routing matches the called party number received from the GMLC. If the called party number conditions are satisfied, the MT-LR shall be allowed if the MS user subscribes to either location without notification or location with notification. If the MS user subscribes to location with notification and privacy verification, the MT-LR shall be allowed following notification to the MS if the MS user either returns a response indicating that location is allowed or returns no response but subscribes to allowing location in the absence of a response. In all other cases, the MT-LR shall be restricted.

If the MS subscribes to the non-call related class, an MT-LR may be allowed by the network if the identity of the LCS client or LCS client group supplied by the GMLC matches the identity of any LCS Client or LCS Client group contained in the MS's SLPP and any other GMLC restrictions associated with this LCS Client identity in the SLPP are also met. If the LCS client is correctly matched in this way and any GMLC restrictions are satisfied, the MT-LR shall be allowed if the MS user subscribes to either location without notification or location with notification. If the MS user subscribes to location with notification and privacy verification, the MT-LR shall be allowed following notification to the MS if the MS user either returns a response indicating that location is allowed or returns no response but subscribes to location in the absence of a response. In all other cases, the MT-LR shall be restricted.

If the MS subscribes to the non-call related class, an MT-LR from an LCS client that is not contained in the MS's SLPP shall be allowed or restricted according to the following conditions. For any non-matched LCS client, the MT-LR shall be allowed if the MS user subscribes to location with notification. If the MS user subscribes to location with notification and privacy verification, the MT-LR shall be allowed following notification to the MS if the MS user either returns a response indicating that location is allowed or returns no response but subscribes to location in the absence of a response. In all other cases, the MT-LR shall be restricted.

If the MS subscribes to the PLMN class, an NI-LR or MT-LR shall be allowed if the client within the VPLMN, for an NI-LR, or the client identified by the GMLC, for an MT-LR, either matches a generic type of client contained in the MS's SLPP or is otherwise authorized by local regulatory requirements to locate the MS.

In evaluating privacy where any address "A" associated with the LCS client (e.g. LCS client ID or GMLC address) needs to be compared with a corresponding address "B" in the target MS's SLPP, a match shall be determined if a match is found for each of the following components of each address:

- a) Numbering Plan
- b) Nature of Address Indicator
- c) Corresponding address digits for all digits in "B" (the digits or initial digits in "A" must match all the digits in "B", but "A" may contain additional digits beyond those in "B")

All addresses shall be transferred to the MSC/VLR in international format, except for the called party number received from the GMLC during a Call Related MT-LR when the LCS client was reached via IN or abbreviated number routing (e.g. toll free number or emergency call routing). In these cases it is up to the GMLC to use the valid national specific number of the visited country.

*** NEXT MODIFIED SECTION ***

12.3 GMLC

The GMLC holds data for a set of external LCS clients that may make call related or non-call related MT-LR requests to this GMLC. The permanent data administered for each LCS client is as follows.

Table10: GMLC Permanent Data for a LCS Client

LCS Client data in GMLC	Status	Description
LCS Client Type	M	Identifies the type LCS client from among the following: <ul style="list-style-type: none"> - Emergency Services - Value Added Services - PLMN Operator Services - Lawful Intercept Services
External identity	M	A list of one or more identifiers used to identify an external LCS client when making an MT-LR – the nature and content of the identifier(s) is outside the scope of this specification
Authentication data	M	Data employed to authenticate the identity of an LCS client – details are outside the scope of this specification
Call related identity	O	A list of one or more international E.164 addresses to identify the client for a call related MT-LR. <u>In case the LCS client was reached via IN or abbreviated number routing (e.g. toll free number or emergency call routing), the E.164 number(s) stored in the GMLC shall be the number(s) that the MS has to dial to reach the LCS Client. In these cases the E.164 number is not to be in international format. The country in which the national specific number(s) is (are) applicable is (are) also stored (or implied) in this case.</u> Each call related identity may be associated with a specific external identity
Non-call related identity	O	A list of one ore more international E.164 addresses to identify the client for a non-call related MT-LR. Each non-call related identity may be associated with a specific external identity
Override capability	O	Indication of whether the LCS client possesses the override capability (not applicable to a value added client)
Authorized MS List	O	A list of MSISDNs or groups of MSISDN for which the LCS client may issue a non-call related MT-LR. Separate lists of MSISDNs and groups of MSISDN may be associated with each distinct external or non-call related client identity.
Priority	M	The priority of the LCS client – to be treated as either the default priority when priority is not negotiated between the LCS server and client or the highest allowed priority when priority is negotiated
QoS parameters	M	The default QoS requirements for the LCS client, comprising: <ul style="list-style-type: none"> - Accuracy - Response time Separate default QoS parameters may be maintained for each distinct LCS client identity (external, non-call related, call related)
Allowed LCS Request Types	M	Indicates which of the following are allowed: <ul style="list-style-type: none"> - Non-call related MT-LR - Call related MT-LR - Specification or negotiation of priority - Specification or negotiation of QoS parameters - Request of current location - Request of current or last known location
Local Coordinate System	O	Definition of the coordinate system(s) in which a location estimate shall be provided – details are outside the scope of this specification
Access Barring List(s)	O	List(s) of MSISDNs or groups of MSISDN for which a location request is barred

*** NEXT MODIFIED SECTION ***

A.3 Call Related MT-LR

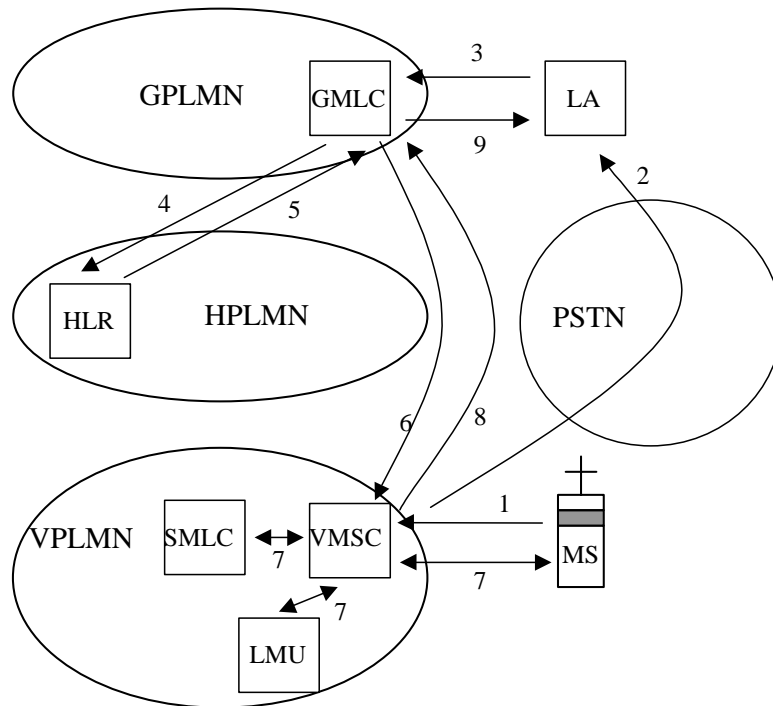

Figure A.2: Call Related MT-LR

1. An MS requests a voice or data call to some external Location Application (LA).
2. The call is routed from the VMSC through the PSTN to the LA. The MSC stores the original dialed number, ~~and the PSTN or PSPDN number that was used to route the call if different.~~
3. The external LA obtains the MSISDN of the calling MS – either verbally or using calling line ID presentation. The LA may also need to verify the number dialed by the MS – e.g. if the LA can be reached by any of several dialed numbers. The external LA sends a Location Request to a GMLC in its serving GPLMN requesting the location of the MS and providing both the MSISDN and ~~its own PSTN PSPDN, the number as used, dialed by the MS.~~
4. The GMLC queries the HLR of the MS to be located by sending a MAP query to the HPLMN of this MS. In order to route the query to the HLR, translation of the MSISDN of the MS to be located will be required. This translation may be performed within the GMLC and/or may be performed by intermediate STPs.
5. The HLR returns the E.164 address of the VMSC currently serving the MS in the VPLMN.
6. The GMLC forwards the location request to the VMSC and includes within it the ~~PSTN or PSPDN~~ number of the LA dialed by the MS. In order to route the request to the VMSC, translation of the E.164 address of the VMSC will be required. This translation may be performed within the GMLC and/or may be performed by intermediate STPs.
7. The VMSC verifies that the MS allows a call related MT-LR in its privacy exception list, that it currently has an originated call established and that the ~~LA, PSTN or PSPDN~~ number supplied by the GMLC matches the number ~~either dialed by the MS, or used to route the call.~~ The VMSC then interacts with an SMLC and possibly one or more LMUs in the VPLMN to perform positioning of the MS.
8. The resulting location estimate is returned by the VMSC to the GMLC. The VMSC uses the E.164 address or SS7 signaling point code of the GMLC, provided in step 4, to correctly route the location estimate to the GMLC in the GPLMN.
9. The GMLC returns the location estimate to the requesting LA.

CHANGE REQUEST

⌘ **TS 03.71 CR A023** ⌘ rev **32** ⌘ Current version: **7.5.0** ⌘

For **HELP** on using this form, see bottom of this page or look at the pop-up text over the ⌘ symbols.

Proposed change affects: ⌘ (U)SIM ME/UE Radio Access Network Core Network

Title:	⌘ Correction of Inconsistent Text		
Source:	⌘ Ericsson and, Motorola and Qualcomm		
Work item code:	⌘	Date:	⌘ 7 May 01
Category:	⌘ F	Release:	⌘ Release 1998
Use <u>one</u> of the following categories:		Use <u>one</u> of the following releases:	
F (essential correction)		2 (GSM Phase 2)	
A (corresponds to a correction in an earlier release)		R96 (Release 1996)	
B (Addition of feature),		R97 (Release 1997)	
C (Functional modification of feature)		R98 (Release 1998)	
D (Editorial modification)		R99 (Release 1999)	
Detailed explanations of the above categories can be found in 3GPP TR 21.900.		REL-4 (Release 4)	
		REL-5 (Release 5)	

Reason for change:	⌘ Make descriptions consistent with the Stage 3 specs and agreed principle that all assistance messages are optional to allow enough flexibility and to reduce traffic flow, which will in turn benefit future enhancement. Make sure that the broadcast messages specified in Stage 3 are described properly.
Summary of change:	⌘ Change the wording
Consequences if not approved:	⌘ It would lead to unnecessary confusion, inconsistency, and inefficiency.

Clauses affected:	⌘ 10.1, 10.2, 10.3
Other specs affected:	⌘ <input type="checkbox"/> Other core specifications ⌘
	<input type="checkbox"/> Test specifications
	<input type="checkbox"/> O&M Specifications
Other comments:	⌘

How to create CRs using this form:

Comprehensive information and tips about how to create CRs can be found at: http://www.3gpp.org/3G_Specs/CRs.htm. Below is a brief summary:

- 1) Fill out the above form. The symbols above marked ⌘ contain pop-up help information about the field that they are closest to.
- 2) Obtain the latest version for the release of the specification to which the change is proposed. Use the MS Word "revision marks" feature (also known as "track changes") when making the changes. All 3GPP specifications can be downloaded from the 3GPP server under <ftp://www.3gpp.org/specs/> For the latest version, look for the directory name with the latest date e.g. 2000-09 contains the specifications resulting from the September 2000 TSG meetings.
- 3) With "track changes" disabled, paste the entire CR form (use CTRL-A to select it) into the specification just in front of the clause containing the first piece of changed text. Delete those parts of the specification which are not relevant to the change request.

***** NEXT MODIFIED SECTION *****

10 E-OTD and GPS Positioning Procedures

10.1 General Procedures

For any location request where the highest priority level is assigned and MS-based GPS positioning is not used, the SMLC shall provide sufficient assistance data to a target MS to enable a location estimate or location measurements to succeed according to the required QoS on the first attempt. The SMLC shall not assume in this case that the target MS already possesses assistance data. For a lower priority location request or when MS-based GPS positioning is used, the SMLC may reduce the assistance data provided to a target MS on the first location attempt. For these cases, sections 10.2 and 10.3 indicate what reduced assistance data may be provided.

In the high priority case with MS-assisted GPS for the first positioning attempt, acquisition assistance data shall be included in the RRLP MEASURE POSITION REQUEST.

10.2 Positioning for BSS based SMLC

This signaling flow is generic for all MS based or assisted location methods (MS Based E-OTD, MS Assisted E-OTD, GPS and Assisted GPS). If the SMLC desires to avoid lower layer (e.g. BSSAP-LE) segmentation and transfer the LCS assistance data more reliably, this procedure may be preceded by an “Assistance Data Delivery from BSS based SMLC” procedure. Note that part of the entire set of assistance data may be included in the RRLP Measure Position Request even when the message is preceded by an “Assistance Data Delivery from BSS based SMLC” procedure.

Figure 54: E-OTD/GPS Positioning Flow

1. The SMLC may precede the RRLP MEASURE POSITION REQUEST with an optional Assistance Data Delivery from BSS based SMLC procedure (see 10.4).
2. The SMLC determines possible assistance data and sends RRLP MEASURE POSITION REQUEST to the BSC.
3. The BSC forwards the positioning request including the QoS and any assistance data to the MS in a RRLP MEASURE POSITION REQUEST.
4. The MS performs the requested E-OTD or GPS measurements, if needed assistance data is available in the MS. If the MS is able to calculate its own location and this is required and needed assistance data is available in MS, the MS computes a location estimate based on E-OTD or GPS measurements. In case of E-OTD, any data necessary to perform these operations will either be provided in the RRLP MEASURE POSITION REQUEST request or available from broadcast sources. In case of Assisted GPS and first positioning attempt, a minimum set of Acquisition Assistance data and optionally Differential-GPS assistance data will be either provided in the RRLP MEASURE POSITION REQUEST or available from broadcast sources. ~~In case of MS based GPS and~~ For further positioning attempt (failure in first attempt due to missing assistance data), ~~completesufficient~~ sufficient GPS assistance data, possibly excluding the assistance data sent in the first attempt ~~Acquisition Assistance data,~~ will be provided in the RRLP MEASURE POSITION REQUEST and possibly preceding RRLP ASSISTANCE DATA messages. The resulting E-OTD or GPS measurements or E-OTD or GPS location estimate are returned to the BSC in a RRLP MEASURE POSITION RESPONSE. If the MS was unable to perform the necessary measurements, or compute a location, a failure indication identifying the reason for failure (e.g. missing assistance data) is returned instead.
5. BSC forwards the RRLP MEASURE POSITION response to SMLC.

10.3 Positioning for NSS based SMLC

This signaling flow is generic for all MS based or assisted location methods (MS Based E-OTD, MS Assisted E-OTD, GPS and Assisted GPS). If the SMLC desires to avoid lower layer (e.g. BSSAP-LE) segmentation and transfer the LCS

assistance data more reliably, this procedure may be preceded by an “Assistance Data Delivery from NSS based SMLC” procedure. Note that part of the entire set of assistance data may be included in the RRLP Measure Position Request even when the message is preceded by an “Assistance Data Delivery from NSS based SMLC” procedure.

Figure 55: E-OTD/GPS Positioning Flow

1. The SMLC may precede the RRLP MEASURE POSITION REQUEST with an optional Assistance Data Delivery from NSS based SMLC procedure (see 10.5).
2. The SMLC determines possible assistance data and sends RRLP MEASURE POSITION REQUEST to MSC.
3. The MSC forwards the RRLP MEASURE POSITION REQUEST to the BSC.
4. The BSC sends the positioning request including the QoS and any assistance data to the MS in a RRLP MEASURE POSITION REQUEST.
5. The MS performs the requested E-OTD or GPS measurements, if needed assistance data is available in MS. If the MS is able to calculate its own location and this is required and needed assistance data is available in MS, the MS computes an E-OTD or GPS location estimate. In case of E-OTD, any data necessary to perform these operations will be either provided in the RRLP MEASURE POSITIOIN REQUEST request or available from broadcast sources. In case of Assisted GPS and first positioning attempt, a minimum set of Acquisition Assistance data and optionally Differential-GPS assistance data will be either provided in the RRLP MEASURE POSITION REQUEST or available from broadcast sources. ~~In case of MS based GPS and~~For further positioning attempt (failure in first attempt due to missing assistance data), ~~complete~~sufficient GPS assistance data, ~~possibly excluding the assistance data sent in the first attempt~~Acquisition Assistance data, will be provided in the RRLP MEASURE POSITION REQUEST and possibly preceding RRLP ASSISTANCE DATA messages. The resulting E-OTD or GPS measurements or E-OTD or GPS location estimate are returned to the BSC in a RRLP MEASURE POSITION RESPONSE. If the MS was unable to perform the necessary measurements, or compute a location, a failure indication identifying the reason for failure (e.g. missing assistance data) is returned instead.
6. BSC sends measurement results in the MEASURE POSITION RESPONSE within BSSMAP Connection Oriented Information message to MSC.
7. MSC forwards the measurement results in the MEASURE POSITION RESPONSE within LCS Information Report message to SMLC.

CHANGE REQUEST

⌘ **TS 03.71 CR A024** ⌘ rev **32** ⌘ Current version: **8.1.0** ⌘

For **HELP** on using this form, see bottom of this page or look at the pop-up text over the ⌘ symbols.

Proposed change affects: ⌘ (U)SIM ME/UE Radio Access Network Core Network

Title:	⌘ Correction of Inconsistent Text		
Source:	⌘ Ericsson and, Motorola and Qualcomm		
Work item code:	⌘	Date:	⌘ 7 May 01
Category:	⌘ A	Release:	⌘ Release 1999
Use <u>one</u> of the following categories: F (essential correction) A (corresponds to a correction in an earlier release) B (Addition of feature), C (Functional modification of feature) D (Editorial modification) Detailed explanations of the above categories can be found in 3GPP TR 21.900.		Use <u>one</u> of the following releases: 2 (GSM Phase 2) R96 (Release 1996) R97 (Release 1997) R98 (Release 1998) R99 (Release 1999) REL-4 (Release 4) REL-5 (Release 5)	

Reason for change:	⌘ Make descriptions consistent with the State <u>Stage 3</u> specs and agreed principle that all assistance messages are optional to allow enough flexibility and to reduce traffic flow, which will in turn benefit future enhancement. Make sure that the broadcast messages specified in Stage 3 are described properly.
Summary of change:	⌘ Change the wording
Consequences if not approved:	⌘ It would lead to unnecessary confusion, inconsistency, and inefficiency.

Clauses affected:	⌘ 10.1, 10.2, 10.3		
Other specs affected:	<input type="checkbox"/> Other core specifications <input type="checkbox"/> Test specifications <input type="checkbox"/> O&M Specifications	⌘	
Other comments:	⌘		

How to create CRs using this form:

Comprehensive information and tips about how to create CRs can be found at: http://www.3gpp.org/3G_Specs/CRs.htm. Below is a brief summary:

- 1) Fill out the above form. The symbols above marked ⌘ contain pop-up help information about the field that they are closest to.
- 2) Obtain the latest version for the release of the specification to which the change is proposed. Use the MS Word "revision marks" feature (also known as "track changes") when making the changes. All 3GPP specifications can be downloaded from the 3GPP server under <ftp://www.3gpp.org/specs/> For the latest version, look for the directory name with the latest date e.g. 2000-09 contains the specifications resulting from the September 2000 TSG meetings.
- 3) With "track changes" disabled, paste the entire CR form (use CTRL-A to select it) into the specification just in front of the clause containing the first piece of changed text. Delete those parts of the specification which are not relevant to the change request.

***** NEXT MODIFIED SECTION *****

10 E-OTD and GPS Positioning Procedures

10.1 General Procedures

For any location request where the highest priority level is assigned and MS-based GPS positioning is not used, the SMLC shall provide sufficient assistance data to a target MS to enable a location estimate or location measurements to succeed according to the required QoS on the first attempt. The SMLC shall not assume in this case that the target MS already possesses assistance data. For a lower priority location request or when MS-based GPS positioning is used, the SMLC may reduce the assistance data provided to a target MS on the first location attempt. For these cases, sections 10.2 and 10.3 indicate what reduced assistance data may be provided.

In the high priority case with MS-assisted GPS for the first positioning attempt, acquisition assistance data shall be included in the RRLP MEASURE POSITION REQUEST.

10.2 Positioning for BSS based SMLC

This signaling flow is generic for all MS based or assisted location methods (MS Based E-OTD, MS Assisted E-OTD, GPS and Assisted GPS). If the SMLC desires to avoid lower layer (e.g. BSSAP-LE) segmentation and transfer the LCS assistance data more reliably, this procedure may be preceded by an “Assistance Data Delivery from BSS based SMLC” procedure. Note that part of the entire set of assistance data may be included in the RRLP Measure Position Request even when the message is preceded by an “Assistance Data Delivery from BSS based SMLC” procedure.

Figure 54: E-OTD/GPS Positioning Flow

1. The SMLC may precede the RRLP MEASURE POSITION REQUEST with an optional Assistance Data Delivery from BSS based SMLC procedure (see 10.4).
2. The SMLC determines possible assistance data and sends RRLP MEASURE POSITION REQUEST to the BSC.
3. The BSC forwards the positioning request including the QoS and any assistance data to the MS in a RRLP MEASURE POSITION REQUEST.
4. The MS performs the requested E-OTD or GPS measurements, if needed assistance data is available in the MS. If the MS is able to calculate its own location and this is required and needed assistance data is available in MS, the MS computes a location estimate based on E-OTD or GPS measurements. In case of E-OTD, any data necessary to perform these operations may will be either be provided in the RRLP MEASURE POSITION REQUEST request or available from broadcast sources. In case of Assisted GPS and first positioning attempt, a minimum set of Acquisition Assistance data and optionally Differential GPS assistance data may will be either provided in the RRLP MEASURE POSITION REQUEST or available from broadcast sources. In case of MS based GPS and For further positioning attempt (failure in first attempt due to missing assistance data), completesufficient GPS assistance data, possibly excluding the assistance data sent in the first attemptAcquisition Assistance data, will be provided in the RRLP MEASURE POSITION REQUEST and possibly preceding RRLP ASSISTANCE DATA messages. The resulting E-OTD or GPS measurements or E-OTD or GPS location estimate are returned to the BSC in a RRLP MEASURE POSITION RESPONSE. If the MS was unable to perform the necessary measurements, or compute a location, a failure indication identifying the reason for failure (e.g. missing assistance data) is returned instead.
5. BSC forwards the RRLP MEASURE POSITION response to SMLC.

10.3 Positioning for NSS based SMLC

This signaling flow is generic for all MS based or assisted location methods (MS Based E-OTD, MS Assisted E-OTD, GPS and Assisted GPS). If the SMLC desires to avoid lower layer (e.g. BSSAP-LE) segmentation and transfer the LCS

assistance data more reliably, this procedure may be preceded by an “Assistance Data Delivery from NSS based SMLC” procedure. Note that part of the entire set of assistance data may be included in the RRLP Measure Position Request even when the message is preceded by an “Assistance Data Delivery from NSS based SMLC” procedure.

Figure 55: E-OTD/GPS Positioning Flow

1. The SMLC may precede the RRLP MEASURE POSITION REQUEST with an optional Assistance Data Delivery from NSS based SMLC procedure (see 10.5).
2. The SMLC determines possible assistance data and sends RRLP MEASURE POSITION REQUEST to MSC.
3. The MSC forwards the RRLP MEASURE POSITION REQUEST to the BSC.
4. The BSC sends the positioning request including the QoS and any assistance data to the MS in a RRLP MEASURE POSITION REQUEST.
5. The MS performs the requested E-OTD or GPS measurements, if needed assistance data is available in MS. If the MS is able to calculate its own location and this is required and needed assistance data is available in MS, the MS computes an E-OTD or GPS location estimate. In case of E-OTD, any data necessary to perform these operations ~~may~~ will be either provided in the RRLP MEASURE POSITIOIN REQUEST request or available from broadcast sources. In case of Assisted GPS and first positioning attempt, a minimum set of Acquisition Assistance data and optionally Differential-GPS assistance data ~~may~~ will be either provided in the RRLP MEASURE POSITION REQUEST or available from broadcast sources. ~~In case of MS based GPS and~~ For further positioning attempt (failure in first attempt due to missing assistance data), ~~complete~~ sufficient GPS assistance data, possibly excluding the assistance data sent in the first attempt ~~Acquisition Assistance data,~~ will be provided in the RRLP MEASURE POSITION REQUEST and possibly preceding RRLP ASSISTANCE DATA messages. The resulting E-OTD or GPS measurements or E-OTD or GPS location estimate are returned to the BSC in a RRLP MEASURE POSITION RESPONSE. If the MS was unable to perform the necessary measurements, or compute a location, a failure indication identifying the reason for failure (e.g. missing assistance data) is returned instead.
6. BSC sends measurement results in the MEASURE POSITION RESPONSE within BSSMAP Connection Oriented Information message to MSC.
7. MSC forwards the measurement results in the MEASURE POSITION RESPONSE within LCS Information Report message to SMLC.

CR-Form-v3

CHANGE REQUEST

⌘ **23.171 CR 018** ⌘ rev **1** ⌘ Current version: **3.3.0** ⌘

For **HELP** on using this form, see bottom of this page or look at the pop-up text over the ⌘ symbols.

Proposed change affects: ⌘ (U)SIM ME/UE Radio Access Network Core Network

Title:	⌘ LCS location notification messages		
Source:	⌘ Ericsson		
Work item code:	⌘ LCS	Date:	⌘ 2001-May-07
Category:	⌘ D	Release:	⌘ R99
	<i>Use one of the following categories:</i> F (essential correction) A (corresponds to a correction in an earlier release) B (Addition of feature), C (Functional modification of feature) D (Editorial modification) Detailed explanations of the above categories can be found in 3GPP TR 21.900.		<i>Use one of the following releases:</i> 2 (GSM Phase 2) R96 (Release 1996) R97 (Release 1997) R98 (Release 1998) R99 (Release 1999) REL-4 (Release 4) REL-5 (Release 5)

Reason for change:	⌘ The LCS Location Notification Invoke and Return Result messages in the "General Network Positioning for a MT-LR" diagram are followed by a "?".
Summary of change:	⌘ It is proposed to remove the "?" from the LCS Location Notification Invoke and Return Result messages.
Consequences if not approved:	⌘ It would be not clear how to handle LCS location Notification Invoke and Return Result messages.

Clauses affected:	⌘ 8.7.1	
Other specs affected:	<input type="checkbox"/> Other core specifications <input type="checkbox"/> Test specifications <input type="checkbox"/> O&M Specifications	⌘
Other comments:	⌘	

How to create CRs using this form:

Comprehensive information and tips about how to create CRs can be found at: http://www.3gpp.org/3G_Specs/CRs.htm. Below is a brief summary:

- 1) Fill out the above form. The symbols above marked ⌘ contain pop-up help information about the field that they are closest to.
- 2) Obtain the latest version for the release of the specification to which the change is proposed. Use the MS Word "revision marks" feature (also known as "track changes") when making the changes. All 3GPP specifications can be downloaded from the 3GPP server under <ftp://www.3gpp.org/specs/>. For the latest version, look for the directory name with the latest date e.g. 2000-09 contains the specifications resulting from the September 2000 TSG meetings.
- 3) With "track changes" disabled, paste the entire CR form (use CTRL-A to select it) into the specification just in front of the clause containing the first piece of changed text. Delete those parts of the specification which are not relevant to the change request.

8.7.1 Circuit Switched Mobile Terminating Location Request (CS-MT-LR)

Figure 8.4 illustrates general network positioning for LCS clients external to the PLMN. In this scenario, it is assumed that the target UE is identified using either an MSISDN or IMSI.

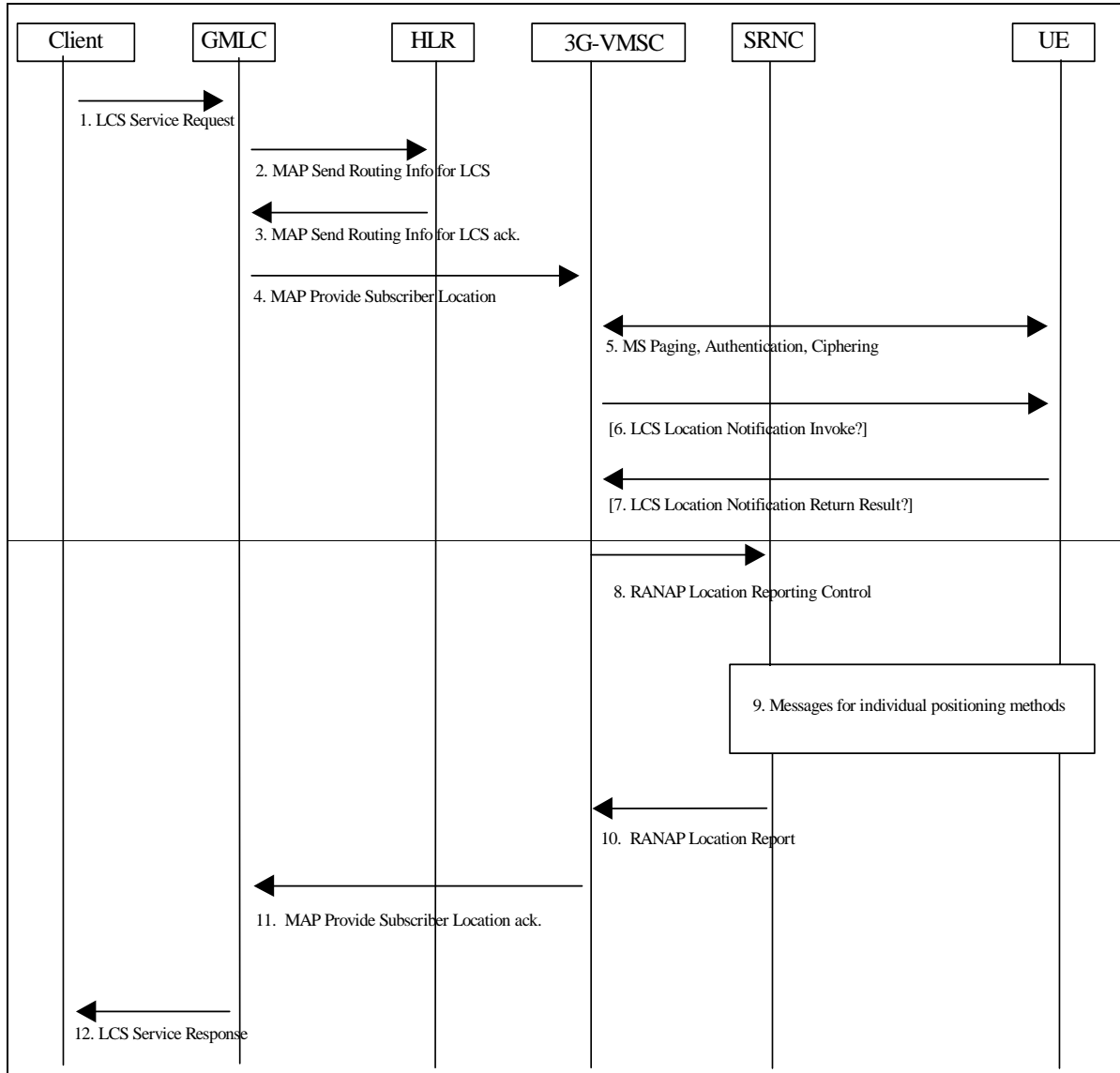

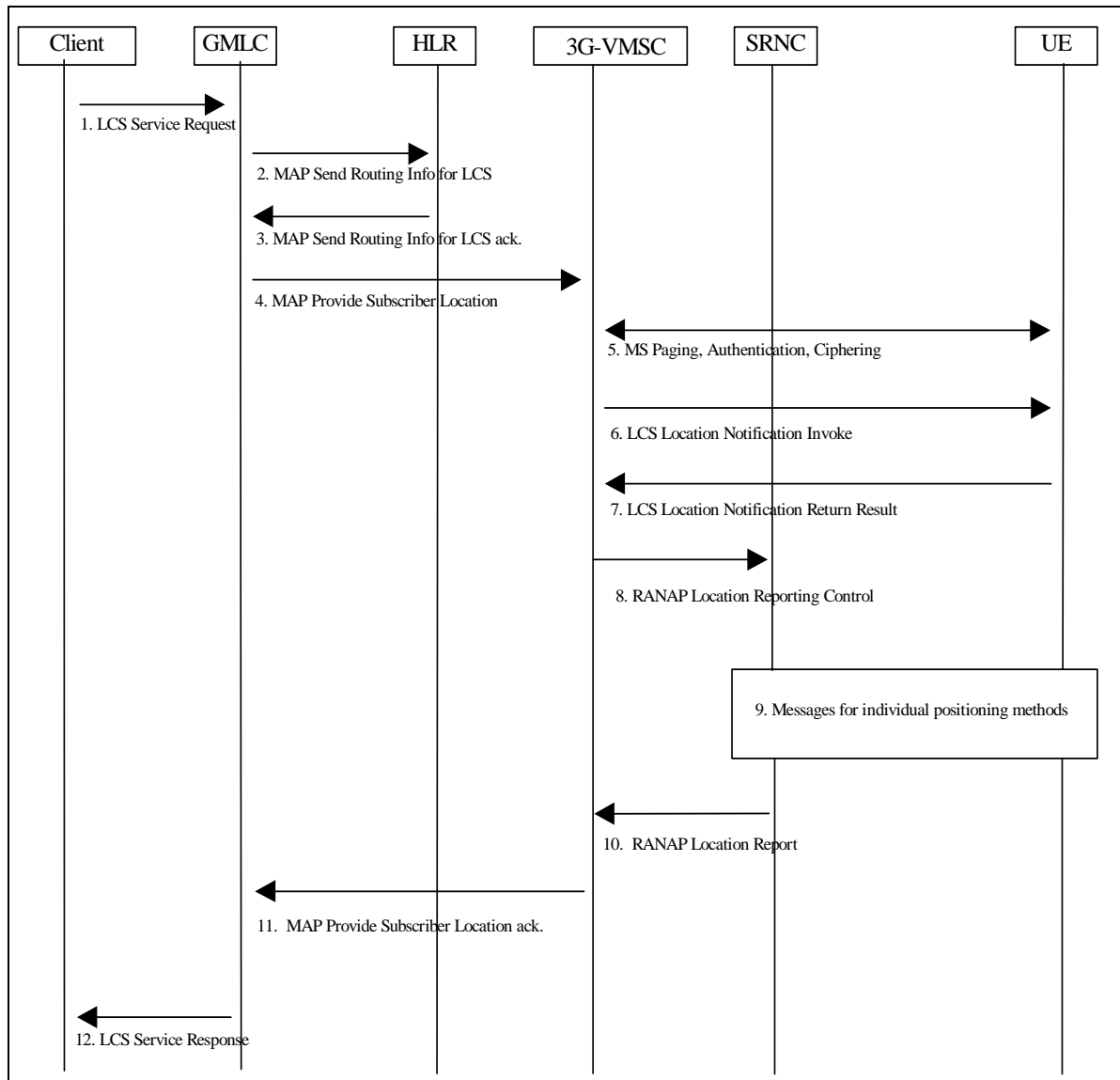

Figure 8.4: General Network Positioning for a MT-LR

8.7.1.1 Location Preparation Procedure

- (1) An external LCS client requests the current location of a target UE from a GMLC. The GMLC verifies the identity of the LCS client and its subscription to the LCS service requested and derives the MSISDN or IMSI of the target UE to be located and the LCS QoS from either subscription data or data supplied by the LCS client. For a call related location request, the GMLC obtains and authenticates the called party number of the LCS client [(refer to Annex A for further details)]. If location is required for more than one UE, or if periodic location is requested, steps 2 to 12 below may be repeated.
- (2) If the GMLC already knows both the 3G-VMSC location and IMSI for the particular MSISDN (e.g. from a previous location request), this step and step 3 may be skipped. Otherwise, the GMLC sends a MAP_SEND_ROUTING_INFO_FOR_LCS message to the home HLR of the target UE to be located with either the IMSI or MSISDN of this UE.
- (3) The HLR verifies that the calling party SCCP address of the GMLC corresponds to a known UMTS network element that is authorized to request UE location information. The HLR then returns the current 3G-VMSC address and whichever of the IMSI and MSISDN was not provided in step (2) for the particular UE.

- (4) The GMLC sends a MAP_PROVIDE_SUBSCRIBER_LOCATION message to the 3G-MSC indicated by the HLR. This message carries the type of location information requested (e.g. current location), the UE subscriber's IMSI, LCS QoS information (e.g. accuracy, response time) and an indication of whether the LCS client has the override capability. For a call related location request, the message also carries the LCS client's called party number. For a value added LCS client, the message shall carry the client name if available and, for a call unrelated location request, the identity of the LCS client. In other cases, inclusion of the client name and/or identity is optional.
- (5) If the GMLC is located in another PLMN or another country, the 3G-VMSC first authenticates that a location request is allowed from this PLMN or from this country. If not, an error response is returned. The 3G-VMSC then verifies LCS barring restrictions in the UE user's subscription profile in the VLR. In verifying the barring restrictions, barring of the whole location request is assumed if any part of it is barred or any requisite condition is not satisfied. If LCS is to be barred without notifying the target UE and a LCS client accessing a GMLC in the same country does not have the override capability, an error response is returned to the GMLC. Otherwise, if the UE is in idle mode, the Core Network performs paging, authentication and ciphering. If the target UE supports any UE based or UE assisted positioning method(s), the UE will also provide the SRNC and MSC with the positioning method(s) it supports via controlled early classmark sending. If the UE is instead in dedicated mode, the VMSC will already have any early classmark information.

[GSM LCS: If the target UE has an established circuit call other than speech, the location request may be denied and an error response is then returned to the GMLC. If the location request is allowed for a non-speech circuit call, it shall be up to the SRNC to decide, on the basis of the applicable position methods and requested QoS, whether positioning is possible. [this is FFS]]

- (6) If the location request comes from a value added LCS client and the UE subscription profile indicates that the UE must either be notified or notified with privacy verification and the UE supports notification of LCS (according to the UE Classmark 2), an LCS Location Notification Invoke message is sent to the target UE indicating the type of location request (e.g. current location) and the identity of the LCS client and whether privacy verification is required. For a call related location request, the LCS client identity shall be set to the LCS client's called party number if no separate LCS client identity was received from the GMLC. Optionally, the VMSC may after sending the LCS Location Notification Invoke message continue in parallel the location process, i.e. continue to step 8 without waiting for a LCS Location Notification Return Result message in step 7.
- (7) The target UE notifies the UE user of the location request. If privacy verification was requested, the target UE indicates to the UE user whether the location request will be allowed or not allowed in the absence of a response and waits for the user to grant or withhold permission. The UE then returns an LCS Location Notification Return Result to the 3G-VMSC indicating, if privacy verification was requested, whether permission is granted or denied. Optionally, the LCS Location Notification Return Result message can be returned some time after step 6, but before step 11. If the UE user does not respond after a predetermined time period, the VMSC shall infer a "no response" condition. The 3G-VMSC shall return an error response to the GMLC if privacy verification was requested and either the UE user denies permission or there is no response with the UE subscription profile indicating barring of the location request in the absence of a response.
- (8) The 3G-MSC sends a RANAP Reporting Control message to the SRNC. This message includes the type of location information requested, the UE's location capabilities and requested QoS.

8.7.1.2 Positioning Measurement Establishment Procedure

- (9) If the requested location information and the location accuracy within the QoS can be satisfied based on cell coverage, cell ID and, if available, RTT value, the SRNC may send a RANAP Location Report immediately. Otherwise, the SRNC determines the positioning method and instigates the particular message sequence for this method, as specified in UTRAN Stage 2 [1]. If the position method returns position measurements, the SRNC uses them to compute a location estimate. If there has been a failure to obtain position measurements, the SRNC may use the current cell information and, if available, RTT value to derive an approximate location estimate. If the UE returns an already computed location estimate to SRNC using an UE based position method, the SRNC may verify consistency with the current cell and, if available, RTT value. If the location estimate so obtained does not satisfy the requested accuracy or the location attempt failed, e.g. due to missing data, and sufficient response time still remains, the SRNC may instigate a further location attempt using the same (e.g. providing more assistance data to UE) or a different position method. If a vertical location co-ordinate is requested but the SRNC can only obtain horizontal co-ordinates, these may be returned.

In case IPDL is used the SRNC may send a message to the BS/Node B to configure the power cease period of the Node Bs involved in the positioning process. However, if the IPDL alignment is specified in lower layers e.g. layer 1 then the functional split of IPDL processing may partly be included in network elements functionality.

8.7.1.3 Location Calculation and Release Procedure

- (10) When a location estimate best satisfying the requested QoS has been obtained, the SRNC returns it to the 3G-MSC in a Location Report message. If a location estimate could not be obtained, the SRNC returns a Location Report message containing a failure cause and no location estimate.
- (11) The 3G-MSC returns the location information and its age to the GMLC, if the VMSC has not initiated the Privacy Verification process in step 6. If step 6 has been performed for privacy verification, the VMSC returns the location information only, if it has received a LCS Location Notification Return Result indicating that permission is granted. If a LCS Location Notification Return Result message indicating that permission is not granted is received, or there is no response, with the UE subscription profile indicating barring of location in the absence of a response, the VMSC shall return an error response to the GMLC. If the SRNC did not return a successful location estimate, but the privacy checks in steps 6-7 were successfully executed, the 3G-VMSC may return the last known location of the target UE if this is known and the LCS client is requesting the current or last known location. The VLR may then release the Mobility Management connection to the UE, if the UE was previously idle, and the 3G-MSC may record billing information.
- (12) The GMLC returns the UE location estimate to the requesting LCS client. If the LCS client requires it, the GMLC may first transform the universal location co-ordinates provided by the 3G-MSC into some local geographic system. The GMLC may record billing for both the LCS client and inter-network revenue charges from the 3G-MSC's network.

3GPP TSG- SA WG2 (LCS drafting)
Puerto Rico, 14.-18.5.2001

Tdoc S2-011507

CR-Form-v3	CHANGE REQUEST
⌘ 23.271 CR 24 ⌘ rev - ⌘ Current version: 4.1.0 ⌘	

For **HELP** on using this form, see bottom of this page or look at the pop-up text over the ⌘ symbols.

Proposed change affects: ⌘ (U)SIM ME/UE Radio Access Network Core Network

Title:	⌘ Applicability of LCS services in CS domain to GPRS mobile stations		
Source:	⌘ Ericsson		
Work item code:	⌘ LCS	Date:	⌘ 8.5.2001
Category:	⌘ A	Release:	⌘ REL-4
	Use <u>one</u> of the following categories: F (essential correction) A (corresponds to a correction in an earlier release) B (Addition of feature), C (Functional modification of feature) D (Editorial modification) Detailed explanations of the above categories can be found in 3GPP TR 21.900.		Use <u>one</u> of the following releases: 2 (GSM Phase 2) R96 (Release 1996) R97 (Release 1997) R98 (Release 1998) R99 (Release 1999) REL-4 (Release 4) REL-5 (Release 5)

Reason for change:	⌘ There is some inconsistency between 23.060 and 23.271 related to paging handling for CS domain. It is not clear in 23.271 how the CS paging is handled in case the CS terminal even have GPRS capability. In case of CS-MT-LR when the MS is both IMSI and GPRS attached the CS paging can according to 23.060 even be performed via the Gs interface. This possibility is not described in 23.271.
Summary of change:	⌘ This CR updates the 23.271 to reflect the missing paging handling.
Consequences if not approved:	⌘ It is unclear whether the LCS services apply to CS mobile stations that also have GPRS capability.

Clauses affected:	⌘ 3.2 4.1 6.3.5 6.3.7 9.1.2		
Other specs affected:	⌘ <input type="checkbox"/> Other core specifications <input type="checkbox"/> Test specifications <input type="checkbox"/> O&M Specifications	⌘	
Other comments:	⌘ This CR contains the same changes as CRA019 to 03.71 (Rel99).		

How to create CRs using this form:

Comprehensive information and tips about how to create CRs can be found at: http://www.3gpp.org/3G_Specs/CRs.htm. Below is a brief summary:

- 1) Fill out the above form. The symbols above marked ⌘ contain pop-up help information about the field that they are closest to.

- 2) Obtain the latest version for the release of the specification to which the change is proposed. Use the MS Word "revision marks" feature (also known as "track changes") when making the changes. All 3GPP specifications can be downloaded from the 3GPP server under <ftp://www.3gpp.org/specs/> For the latest version, look for the directory name with the latest date e.g. 2000-09 contains the specifications resulting from the September 2000 TSG meetings.
- 3) With "track changes" disabled, paste the entire CR form (use CTRL-A to select it) into the specification just in front of the clause containing the first piece of changed text. Delete those parts of the specification which are not relevant to the change request.

<< first modified section>>

3.2 Symbols

For the purposes of the present document, the following symbols apply:

Gb	<u>Interface between 2G-SGSN and BSS</u>
Gs	<u>Interface between MSC and SGSN</u>
Lc	Interface between gateway MLC and gsmSCF (CAMEL interface)
Le	Interface between External User and MLC (external interface)
Lg	Interface between Gateway MLC - VMSC, GMLC - MSC Server, GMLC - SGSN (gateway MLC interface)
Lh	Interface between Gateway MLC and HLR (HLR interface)
Um	GERAN Air Interface
Uu	UTRAN Air Interface

<< next modified section>>

4.1 Assumptions

As a basis for the further development work on LCS in GSM and UMTS the following assumptions apply:

- positioning methods are Access Network specific, although commonalities should be encouraged between Access Networks;
- commercial location services are only applicable for an UE with a valid SIM or USIM;
- the provision of the location services in the Access Network is optional through support of the specified method(s);
- the provision of location services is optional in MSC and SGSN;
- LCS is applicable to any target UE whether or not the UE supports LCS, but with restrictions on choice of positioning method or notification of a location request to the UE user when LCS or individual positioning methods, respectively, are not supported by the UE;
- LCS shall be applicable for both circuit switched and packet switched services;
- the location information may be used for internal system operations to improve system performance;
- it shall be possible to accommodate future techniques of measurement and processing to take advantage of advancing technology so as to meet new service requirements;
- it may be necessary to support LCS signaling between separate access networks via the core network. The Iur interface should be used if available.
- Provide positioning procedures through the circuit-switched domain are also applicable to GPRS UEs which are GPRS and IMSI attached.

<< next modified section>>

6.3.5 MSC/VLR

The MSC/VLR contains functionality responsible for UE subscription authorization and managing call-related and non-call related positioning requests of LCS. The MSC is accessible to the GMLC via the Lg interface. The LCS functions of MSC are related to charging and billing, LCS co-ordination, location request, authorization and operation of the LCS services. If connected to SGSN through the Gs interface, it checks whether the UE is GPRS attached to decide whether to page the UE on the A/Iu or Gs interface.

<< next modified section>>

6.3.7 SGSN

The SGSN contains functionality responsible for UE subscription authorization and managing positioning requests of LCS. The SGSN is accessible to the GMLC via the Lg interface. The LCS functions of SGSN are related to charging and billing, LCS co-ordination, location request, authorization and operation of the LCS services.

The SGSN forwards the circuit-switched paging request received from the Gs interface to the BSS/RNC.

9.1.2 Circuit Switched Mobile Terminating Location Request (CS-MT-LR)

Figure 9.2 illustrates general network positioning for LCS clients external to the PLMN. In this scenario, it is assumed that the target UE is identified using either an MSISDN or IMSI.

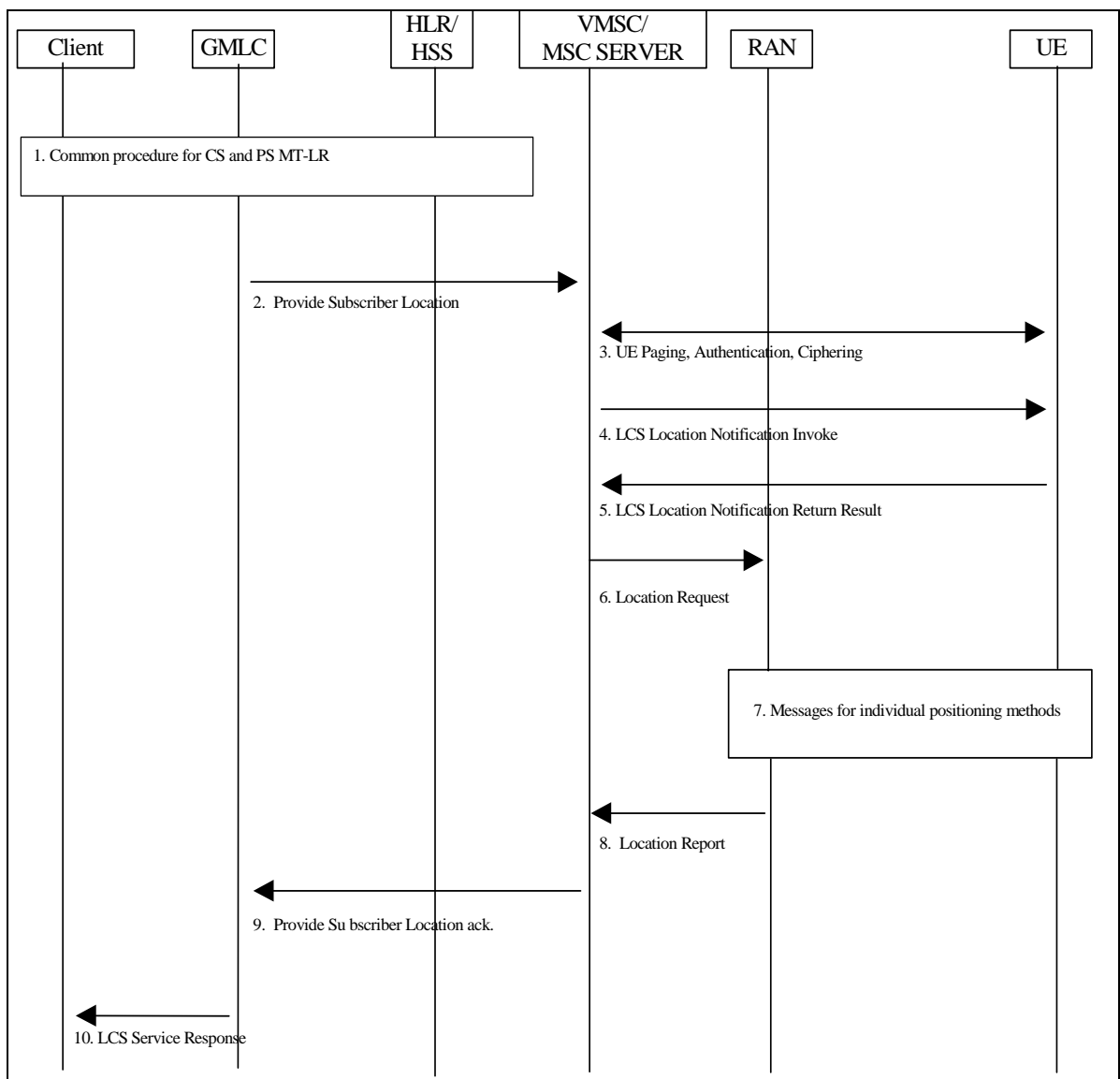

Figure 9.2: Network Positioning for a CS-MT-LR

9.1.2.1 Location Preparation Procedure

- 1) Common PS and CS MT-LR procedure as described in 9.1.1.
- 2) The GMLC sends a PROVIDE_SUBSCRIBER_LOCATION message to the MSC/MSC server indicated by the HLR/HSS. This message carries the type of location information requested (e.g. current location), the UE subscriber’s IMSI, LCS QoS information (e.g. accuracy, response time) and an indication of whether the LCS client has the override capability. For a call related location request, the message also carries the LCS client’s called party number. For a value added LCS client, the message shall carry the client name and the external

identity of the LCS client. For a PLMN operator LCS client, the message shall carry the internal identity of the LCS client.

- 3) If the GMLC is located in another PLMN or another country, the VMSC/MSC server first authenticates that a location request is allowed from this PLMN or from this country. If not, an error response is returned. The VMSC/MSC server then verifies LCS barring restrictions in the UE user's subscription profile in the MSC server. In verifying the barring restrictions, barring of the whole location request is assumed if any part of it is barred or any requisite condition is not satisfied. If LCS is to be barred without notifying the target UE and a LCS client accessing a GMLC in the same country does not have the override capability, an error response is returned to the GMLC. Otherwise, if the UE is in idle mode, the Core Network performs paging, authentication and ciphering. The MSC will page a GPRS attached UE either through A/Iu or Gs interface, depending on the presence of the Gs interface (see Note). The UE will inform the network about its LCS capabilities, as described in chapter 6.3.4.. If the UE is instead in dedicated mode, the VMSC/MSC server will already have UE classmark information. In GSM this is supported by controlled early classmark sending.

[GSM, LCS: If the target UE has an established circuit call other than speech, the location request may be denied and an error response is then returned to the GMLC. If the location request is allowed for a non-speech circuit call, it shall be up to RAN to decide, on the basis of the applicable position methods and requested QoS, whether positioning is possible. [this is FFS]]

Note: In some network mode of operation, a GPRS capable UE may not receive the CS paging. In addition, upon receipt of a CS paging, a GPRS capable UE may immediately answer to the Paging Request or delay the answer, as defined in 3GPP TS 22.060 and 23.060. A GPRS UE in class B mode may also suspend its GPRS traffic, sending a GPRS Suspension Request to the network.

- 4) If the location request comes from a value added LCS client and the UE subscription profile indicates that the UE must either be notified or notified with privacy verification and the UE supports notification of LCS (according to the UE Capability information), an LCS Location Notification Invoke message is sent to the target UE indicating the type of location request (e.g. current location) and the identity of the LCS client and whether privacy verification is required. [FFS: For a call related location request, the LCS client identity shall be set to the LCS client's called party number if no separate LCS client identity was received from the GMLC.] Optionally, the VMSC/MSC server may after sending the LCS Location Notification Invoke message continue in parallel the location process, i.e. continue to step 6 without waiting for a LCS Location Notification Return Result message in step 5.

NOTE 2: This step is for further study, it should be investigated e.g. which client identities to include in the Privacy Notification message to be shown to the end-user.

- 5) The target UE notifies the UE user of the location request. If privacy verification was requested, the target UE indicates to the UE user whether the location request will be allowed or not allowed in the absence of a response and waits for the user to grant or withhold permission. The UE then returns an LCS Location Notification Return Result to the VMSC/MSC server indicating, if privacy verification was requested, whether permission is granted or denied. Optionally, the LCS Location Notification Return Result message can be returned some time after step 4, but before step 9. If the UE user does not respond after a predetermined time period, the VMSC/MSC server shall infer a "no response" condition. The VMSC/MSC server shall return an error response to the GMLC if privacy verification was requested and either the UE user denies permission or there is no response with the UE subscription profile indicating barring of the location request in the absence of a response.
- 6) The MSC/MSC server sends a Location Request message to RAN. This message includes the type of location information requested, the UE's location capabilities and requested QoS.

3GPP TSG- SA WG2 (LCS drafting)
Puerto Rico, 14.-18.5.2001

Tdoc S2-011509
 (Revised S2-011505, S2-011281)

CR-Form-v3

CHANGE REQUEST

⌘ **23.271 CR 22** ⌘ rev **2** ⌘ Current version: **4.1.0** ⌘

For **HELP** on using this form, see bottom of this page or look at the pop-up text over the ⌘ symbols.

Proposed change affects: ⌘ (U)SIM ME/UE Radio Access Network Core Network

Title:	⌘ Alignment of 23.271 with GERAN LCS stage 2, TS 43.059		
Source:	⌘ Nokia		
Work item code:	⌘ LCS	Date:	⌘ 17.5.2001
Category:	⌘ C	Release:	⌘ REL-4
Use <u>one</u> of the following categories: F (essential correction) A (corresponds to a correction in an earlier release) B (Addition of feature), C (Functional modification of feature) D (Editorial modification) Detailed explanations of the above categories can be found in 3GPP TR 21.900.		Use <u>one</u> of the following releases: 2 (GSM Phase 2) R96 (Release 1996) R97 (Release 1997) R98 (Release 1998) R99 (Release 1999) REL-4 (Release 4) REL-5 (Release 5)	

Reason for change:	⌘ In GERAN Rel'4 LCS is only supported in the CS domain. Alignment between TS 43.059 and TS 23.271.
Summary of change:	⌘ Network architecture figure changed and note added, distinction between 2G-SGSN and 3G-SGSN added. References to GSM removed in PS domain parts.
Consequences if not approved:	⌘ Misalignment between TS 23.271 and TS 43.059

Clauses affected:	⌘ 1 2 3.3 5.4.2 6 6.1 Figure 6.2 6.3.7 7.1 8.6 9.1.1 9.1.2 9.1.6 9.1.7 9.2.2 9.4.3
Other specs affected:	⌘ <input type="checkbox"/> Other core specifications ⌘ <input type="checkbox"/> Test specifications <input type="checkbox"/> O&M Specifications
Other comments:	⌘ The text deleted in this CR should be reintroduced in the TS 23.271 Release 5 version.

How to create CRs using this form:

Comprehensive information and tips about how to create CRs can be found at: http://www.3gpp.org/3G_Specs/CRs.htm. Below is a brief summary:

- 1) Fill out the above form. The symbols above marked ⌘ contain pop-up help information about the field that they are closest to.
- 2) Obtain the latest version for the release of the specification to which the change is proposed. Use the MS Word "revision marks" feature (also known as "track changes") when making the changes. All 3GPP specifications can be downloaded from the 3GPP server under <ftp://www.3gpp.org/specs/> For the latest version, look for the directory name with the latest date e.g. 2000-09 contains the specifications resulting from the September 2000 TSG meetings.

Error! No text of specified style in document.

2

Error! No text of specified style in document.

- 3) With "track changes" disabled, paste the entire CR form (use CTRL-A to select it) into the specification just in front of the clause containing the first piece of changed text. Delete those parts of the specification which are not relevant to the change request.

<< first modified section >>

1 Scope

The present document specifies the stage 2 of the LoCation Services (LCS) feature in UMTS and GSM, which provides the mechanisms to support mobile location services for operators, subscribers and third party service providers.

The present document replaces the specifications TS 23.171 (Release 1999) and the system and core network parts of GSM 03.71 (Release 1999)~~[5] in Release 4~~. TS 43.059[16] replaces the radio access network parts of GSM 03.71 (Release 1999).

Location Services may be considered as a network provided enabling technology consisting of standardised service capabilities, which enable the provision of location applications. The application(s) may be service provider specific. The description of the numerous and varied possible location applications which are enabled by this technology are outside the scope of the present document. However, clarifying examples of how the functionality being described may be used to provide specific location services may be included.

This stage 2 service description covers the LCS system functional model for the whole system, the LCS system architecture, state descriptions, message flows, etc.

2 References

The following documents contain provisions which, through reference in this text, constitute provisions of the present document.

- References are either specific (identified by date of publication, edition number, version number, etc.) or non-specific.
- For a specific reference, subsequent revisions do not apply.
- For a non-specific reference, the latest version applies.

2.1 Normative references

- [1] 3G TS 25.305: "Stage 2 functional specification of UE positioning in UTRAN".
- [2] GSM 01.04 (ETR 350): "Abbreviations and acronyms".
- [3] 3G TS 21.905: "UMTS Abbreviations and acronyms".
- [4] 3G TS 22.071: "Technical Specification Group Systems Aspects; Location Services (LCS); Stage 1".
- ~~[5] GSM 03.71: "Location Services (LCS); (Functional description) - Stage 2".~~
- [6] ~~3G TS 48.008~~GSM 08.08: "Mobile-services Switching Centre - Base Station System (MSC - BSS) interface; Layer 3 specification".
- [7] 3G TS 22.100: "UMTS phase 1 (Release 1999)".
- [8] 3G TS 22.101: "Service principles".
- [9] 3G TS 22.105: "Services and Service Capabilities".
- [10] 3G TS 22.115: "Charging and Billing".

- [11] 3G TS 23.032 (GSM 03.32): "Universal Geographical Area Description (GAD)".
- [12] 3G TS 22.121: "The Virtual Home Environment".
- [13] 3G TS 23.110: "UMTS Access Stratum Services and Functions".
- [14] 3G TS 25.413: "UTRAN Iu Interface RANAP signaling".
- [15] 3G TS 23.060: "General Packet Radio Service (GPRS); Service description; Stage 2".
- [16] 3G TS 43.059: "Functional Stage 2 description of Location Services in GERAN".

~~Editor's note: More references to GSM specifications should be added.~~

- [17] 3G TS 23.003: "Numbering, addressing and identification".
- [18] 3G TS 29.002: "Mobile Application Part (MAP) Specification".
- [19] GSM 04.02: "GSM Public Land Mobile Network (PLMN) access reference configuration".
- [20] 3G TS 23.002: "Network architecture".
- [21] 3G TS 23.078: "Customised Applications for Mobile network Enhanced Logic (CAMEL) - stage 2".
- [22] 3G TS 23.011: "Technical realization of Supplementary Services".
- [23] 3G TS 23.007: "Restoration procedures".
- [24] 3G TS 24.008: "Mobile Radio Interface - Layer 3 MM/CC Specification".
- [24a] 3G TS 25.331 "RRC protocol specification".

<< next modified section >>

3.3 Abbreviations

For the purposes of the present document, the following abbreviations apply:

2G-	Second Generation
3G-	Third Generation
AC	Admission Control
AI	Application Interface (prefix to interface class method)
ANM	Answer Message (ISUP)
APN	Access Point Name
ARIB	Association of Radio Industries and Business
ATD	Absolute Time Difference
BCCH	Broadcast Control Channel
BER	Bit Error Rate
BSS	Base Station Subsystem
BTS	Base Transceiver Station
CAMEL	Customised Application For Mobile Network Enhanced Logic
CAP	CAMEL Application Part
CM	Connection Management
CN	Core Network
CSE	Camel Service Environment
DL	Downlink
DRNC	Drift RNC
E-OTD	Enhanced Observed Time Difference
FER	Frame Error Rate
GERAN	GSM EDGE Radio Access Network
GGSN	Gateway GPRS Support Node

GMLC	Gateway MLC
GPRS	General Packet Radio Service
GPS	Global Positioning System
HE	Home Environment
HSS	Home Subscriber Server
HLR	Home Location Register
HPLMN	Home Public Land Mobile Network
IMEI	International Mobile Equipment Identity
IMSI	International Mobile Subscriber Identity
IP	Internet Protocol
IPDL	Idle Period Downlink
LA	Location Application
LAF	Location Application Function
LBS	Location Based Services
LCAF	Location Client Authorization Function
LCCF	Location Client Control Function
LCCTF	Location Client Co-ordinate Transformation Function
LCF	Location Client Function
LCS	LoCation Services
LDR	Location Deferred Request
LIR	Location Immediate Request,
LMU	Location Measurement Unit
LSAF	Location Subscriber Authorization Function
LSBcF	Location System Broadcast Function
LSBF	Location System Billing Function
LSCF	Location System Control Function
LSOF	Location System Operation Function
LSPF	Location Subscriber Privacy Function
MAP	Mobile Application Part
ME	Mobile Equipment
MEExE	Mobile Execution Environment
MLC	Mobile Location Center
MM	Mobility Management
MO-LR	Mobile Originated Location Request
MS	Mobile Station
MSC	Mobile Services switching Center
MSC	Mobile services Switching Centre
MSISDN	Mobile Station Integrated Services Data Network
MT-LR	Mobile Terminated Location Request
NA-ESRD	North American Emergency Service Routing Digits
NA-ESRK	North American Emergency Service Routing Key
NI-LR	Network Induced Location Request
OSA	Open Service Architecture
OTDOA	Observed Time Difference Of Arrival
PC	Power Control
PCF	Power Calculation Function
PLMN	Public Land Mobile Network
POI	Privacy Override Indicator
PRCF	Positioning Radio Co-ordination Function
PRRM	Positioning Radio Resource Management
PSE	Personal Service Environment
PSMF	Positioning Signal Measurement Function
PSTN	Public Switched Telephone Network
QoS	Quality of Service
RA	Routing Area
RACH	Random Access Channel
RAN	Radio Access Network
RANAP	Radio Access Network Application Part
RIS	Radio Interface Synchronization
RNC	Radio Network Controller
RRM	Radio Resource Management
RTD	Real Time Difference

SAT	SIM Application Tool-Kit
SCCP	Signalling Connection Control Part
SGSN	Serving GPRS Support Node
SGSN	Serving GPRS Support Node, <u>SGSN in this specification normally refers to 3G-SGSN only, SGSN in GSM is noted 2G-SGSN</u>
SI	Service Interface (prefix to interface class method)
SIM	Subscriber Identity Module
SIR	Signal Interference Ratio
SLPP	Subscriber LCS Privacy Profile
SMLC	Serving Mobile Location Center
SMS	Short Message Service
SP	Service Point
SRNC	Serving RNC
SS7	Signaling System No 7
TA	Timing Advance
TMSI	Temporary Mobile Subscriber Identity
TOA	Time Of Arrival
UDT	SCCP Unitdata message
UE	User Equipment
UL	Uplink
UMTS	Universal Mobile Telecommunication System
USIM	Universal Subscriber Identity Module
UTRAN	Universal Terrestrial Radio Access Network
VASP	Value Added Service Provider
VHE	Virtual Home Environment
WCDMA	Wideband Code Division Multiple Access

Further GSM related abbreviations are given in GSM 01.04. Further UMTS related abbreviations are given in 3G TS 21.905 [3].

<< next modified section>>

5.4.2 System handling component

5.4.2.1 Location System Control Function(LSCF)

The Location System Control Function (LSCF) is responsible for co-ordinating location requests. This function manages call-related and non-call-related positioning requests of LCS and allocates network resources for handling them. The LSCF retrieves UE classmark information for the purpose of determining the LCS capabilities of UE.

The LSCF performs call setup if required as part of a LCS e.g., putting the UE on dedicated radio resources. It also caters for co-ordinating resources and activities with regard to requests related to providing assistance data needed for positioning. This function interfaces with the LCCF, LSPF, LSBF and PRCF. Using these interfaces, it conveys positioning requests to the PRCF, relays positioning data to the LCCF and passes charging related data to the LSBF.

The U-LSCF for UTRAN is further described in TS 25.305 [1], LSCF for GERAN is described in TS 43.059 [16].

5.4.2.2 Location System Billing Function (LSBF)

The Location System Billing Function (LSBF) is responsible for charging and billing activity within the network related to location services (LCS). This includes charging and billing of both clients and subscribers. Specifically, it collects charging related data and data for accounting between PLMNs.

5.4.2.3 Location System Operations Function (LSOF)

The Location System Operations Function (LSOF) is responsible for provisioning of data, positioning capabilities, data related to clients and subscription (LCS client data and UE data), validation, fault management and performance management of LCS. -An LSOF may be associated with each entity.

[Editor's note: This is being studied in GSM. FFS in UMTS. Internal LCF may be part of O&M functions].

5.4.2.4 Location System Broadcast Function (LSBcF)

The Location System Broadcast Function (LSBcF) provides broadcast capability. The LSBcF capability is only used when broadcast data is required for E-OTD, OTDOA or assisted GPS positioning methods.

6 LCS Architecture

Figure 6.1 shows the general arrangement of the Location Service feature in GSM and UMTS. This illustrates, generally, the relation of LCS Clients and servers in the core network with the GERAN and UTRAN Access Networks. The LCS entities within the Access Network communicate with the Core Network (CN) across the A-Gb and Iu interfaces. Communication among the Access Network LCS entities makes use of the messaging and signaling capabilities of the Access Network.

As part of their service or operation, the LCS Clients may request the location information of UE. There may be more than one LCS client. These may be associated with the GSM/UMTS networks or the Access Networks operated as part of a UE application or accessed by the UE through its access to an application (e.g. through the Internet).

The clients make their requests to a LCS Server. There may be more than one LCS Server. The client must be authenticated and the resources of the network must be co-ordinated including the UE and the calculation functions, to estimate the location of the UE and result returned to the client. As part of this process, information from other systems (other Access Networks) can be used. As part of the location information returned to the client, an estimate of the accuracy of the estimate and the time-of-day the measurement was made may be provided.

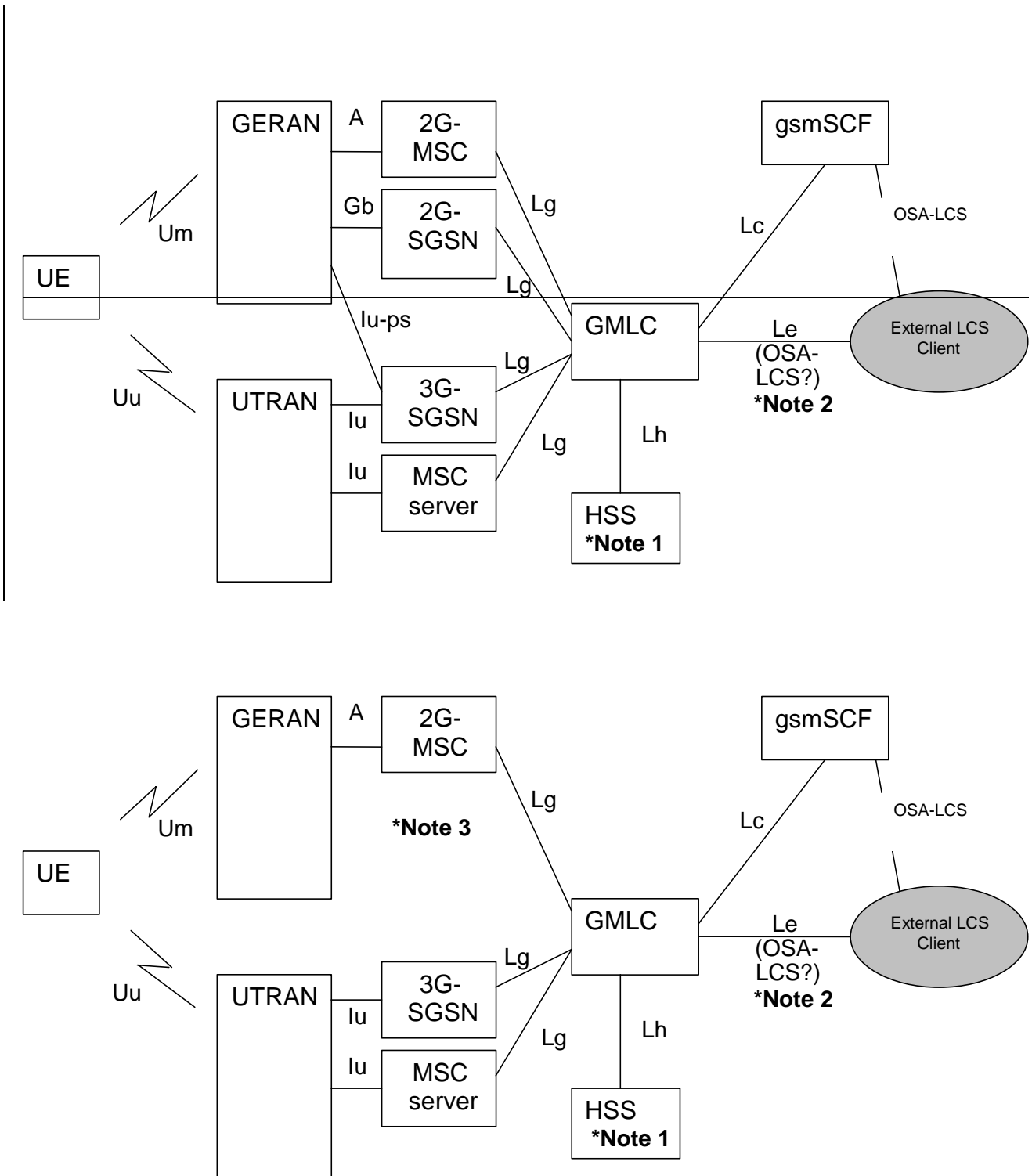

NOTE 1: HSS includes both 2G-HLR and 3G-HLR functionality. LCS should be included in the overall network architecture in TS 23.002 [20].

NOTE 2: The Le interface is FFS. S1 agreed that LCS shall support OSA-API.

NOTE 3: In GSM (Rel-4), positioning is only supported on the A interface

Figure 6.1: General arrangement of LCS

6.1 Schematic functional description of LCS operations

The allocation of LCS functional blocks to the Client, LCS server, Core Network, Access Network and UE is based on the schematic functional description below. The detailed functions and interactions are specified later in the present

document and in TS 25.305 [1] for UTRAN, in TS 43.059 [16] for GERAN and in corresponding Stage 3 specifications.

The operation begins with a LCS Client requesting location information for a UE from the LCS server. The LCS server will pass the request to the LCS functional entities in the core network. The LCS functional entities in the core network shall then:

- verify that the LCS Client is authorized to request the location of the UE or subscriber;
- verify that LCS is supported by the UE;
- establish whether it is allowed to locate the UE or subscriber, for privacy or other reasons;
- establish which network element in the Access Network should receive the Location request;
- request the Access Network (via the A-Gb or Iu interface) to provide location information for an identified UE, with indicated QoS;
- receive information about the location of the UE from the Access Network and forward it to the Client;
- send appropriate accounting information to an accounting function.

The Access Network LCS functional entities shall determine the position of the target UE according to TS 25.305 [1] for UTRAN and TS 43.059 [16] for GERAN.

<< next modified section >>

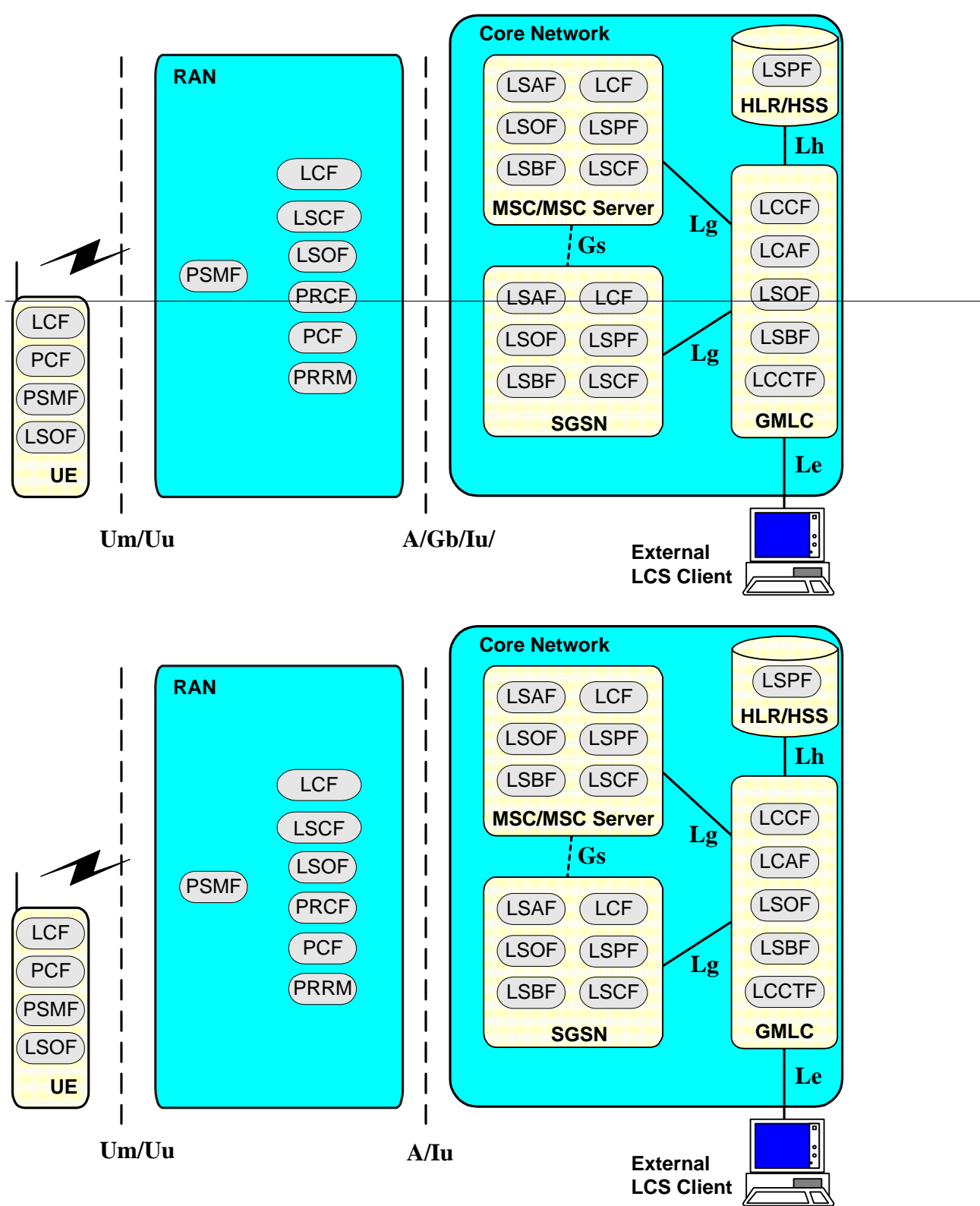

Figure 6.2: Generic LCS Logical Architecture

<< next modified section >>

6.3.7 SGSN

In UMTS, the 3G-SGSN contains functionality responsible for UE subscription authorization and managing positioning requests of LCS. The 3G-SGSN is accessible to the GMLC via the Lg interface. The LCS functions of 3G-

SGSN are related to charging and billing, LCS co-ordination, location request, authorization and operation of the LCS services.

<< next modified section>>

7 Signaling and Interfaces

7.1 LCS signaling between Access and Core Networks

The core network sends location requests to the access network, which then sends the corresponding responses back to the core network.

Communication between access and core networks is accomplished through Iu interface in UMTS, whereas ~~the A, Gb and Iu-ps interfaces are~~ is used for the purpose in GSM (see TS 25.305 [1] and TS 43.059 [16]).

<< next modified section>>

8.6 ~~Gb interface mapping of target UE~~

The pre-requisite for LCS procedures on the Gb interface is that UE is in "ready state".

<< next modified section>>

9.1 Mobile Terminating Location Request

9.1.1 MT-LR routing procedure in PS and CS domain

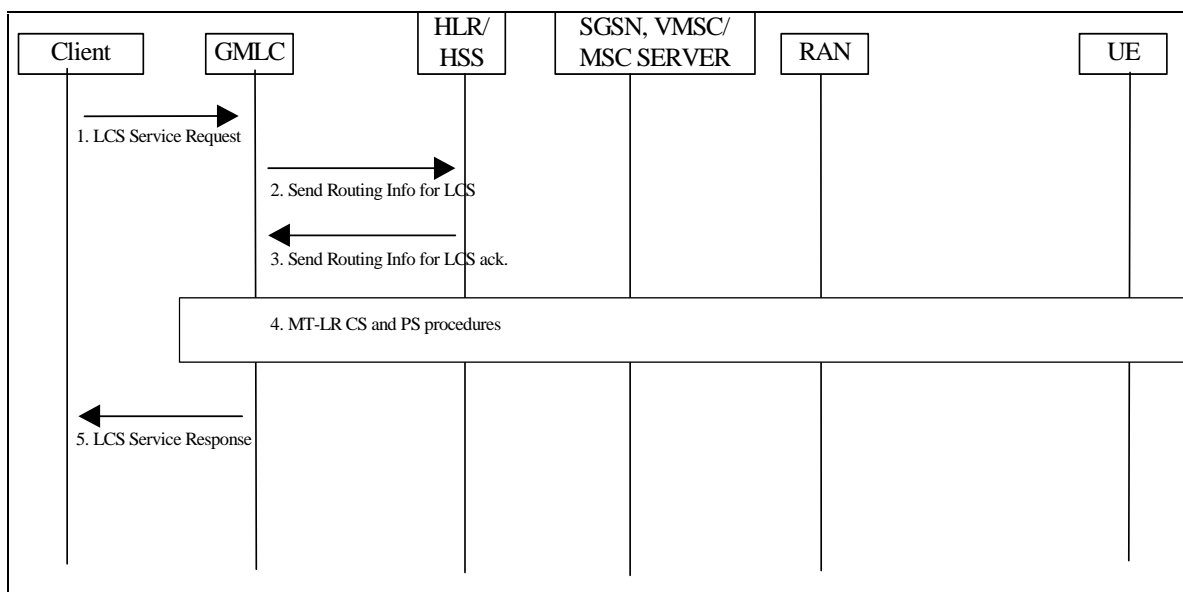

Figure 9.1: General Network Positioning for a MT-LR

- 1) An external LCS client requests the current location of a target UE from a GMLC. The GMLC verifies the identity of the LCS client and its subscription to the LCS service requested and derives the MSISDN or IMSI or PDP address, (NOTE: IP addressing in this context is FFS, one reason is the dynamic IP addressing used in

IPv4.) of the target UE to be located and the LCS QoS from either subscription data or data supplied by the LCS client. For a call related or session related location request, the GMLC obtains and authenticates the called party number of the LCS client. If location is required for more than one UE, or if periodic location is requested, the steps following below may be repeated.

Note: This means that GMLC handles the periodicity of location requests as requested by the LCS client both in CS and PS domain.

- 2) If the GMLC already knows both the VMSC/MSC server or SGSN (Note: only applicable to 3G-SGSN in Rel-4) location and IMSI for the particular MSISDN or PDP address, (e.g. from a previous location request), this step and step 3 may be skipped. Otherwise, the GMLC sends a SEND_ROUTING_INFO_FOR_LCS message to the home HLR/HSS of the target UE to be located with the IMSI, PDP address or MSISDN of this UE.
- 3) The HLR/HSS verifies that the calling party SCCP address of the GMLC corresponds to a known GSM/UMTS network element that is authorized to request UE location information. The HLR/HSS then returns one or several of the addresses, the current SGSN and/or VMSC/MSC server and whichever of the IMSI and MSISDN was not provided in step (2) for the particular UE.
Note: HLR may prioritize between the MSC/VLR or SGSN address sent to GMLC. The priority criteria are for further study.
- 4) In case GMLC receives only the MSC/VLR address, the MT LR proceeds as the CS-MT-LR procedure described in 9.1.2. In case GMLC receives only the SGSN address, the MT LR proceeds as the PS-MT-LR procedure described in 9.1.6. In case the GMLC receives several of the following addresses, SGSN, VMSC and/or MSC Server, it has to decide where to send the location request. If the requested MT-LR is known to be associated with a CS call, the CS-MT-LR procedure shall be invoked. If the requested MT-LR is associated with a PS session, the PS-MT-LR procedure only shall be invoked. Otherwise, both CS-MT-LR and PS-MT-LR are applicable.

Note: The order in which these procedures are invoked and whether one or both procedures are used may depend on subscription information for the LCS client, possible priority information returned by the HSS or information already stored in the GMLC (e.g. obtained from previous location requests).

- 5) GMLC sends the location service response to the LCS client. If the LCS client requires it, the GMLC may first transform the universal location co-ordinates provided by the SGSN or MSC/MSC server into some local geographic system. The GMLC may record billing for both the LCS client and inter-network revenue charges from the SGSN or MSC/MSC server's network.

The detailed CS-MT-LR and PS-MT-LR procedures in step 4 of figure 9.1 are described in 9.1.2 and 9.1.6.

9.1.2 Circuit Switched Mobile Terminating Location Request (CS-MT-LR)

Figure 9.2 illustrates general network positioning for LCS clients external to the PLMN. In this scenario, it is assumed that the target UE is identified using either an MSISDN or IMSI.

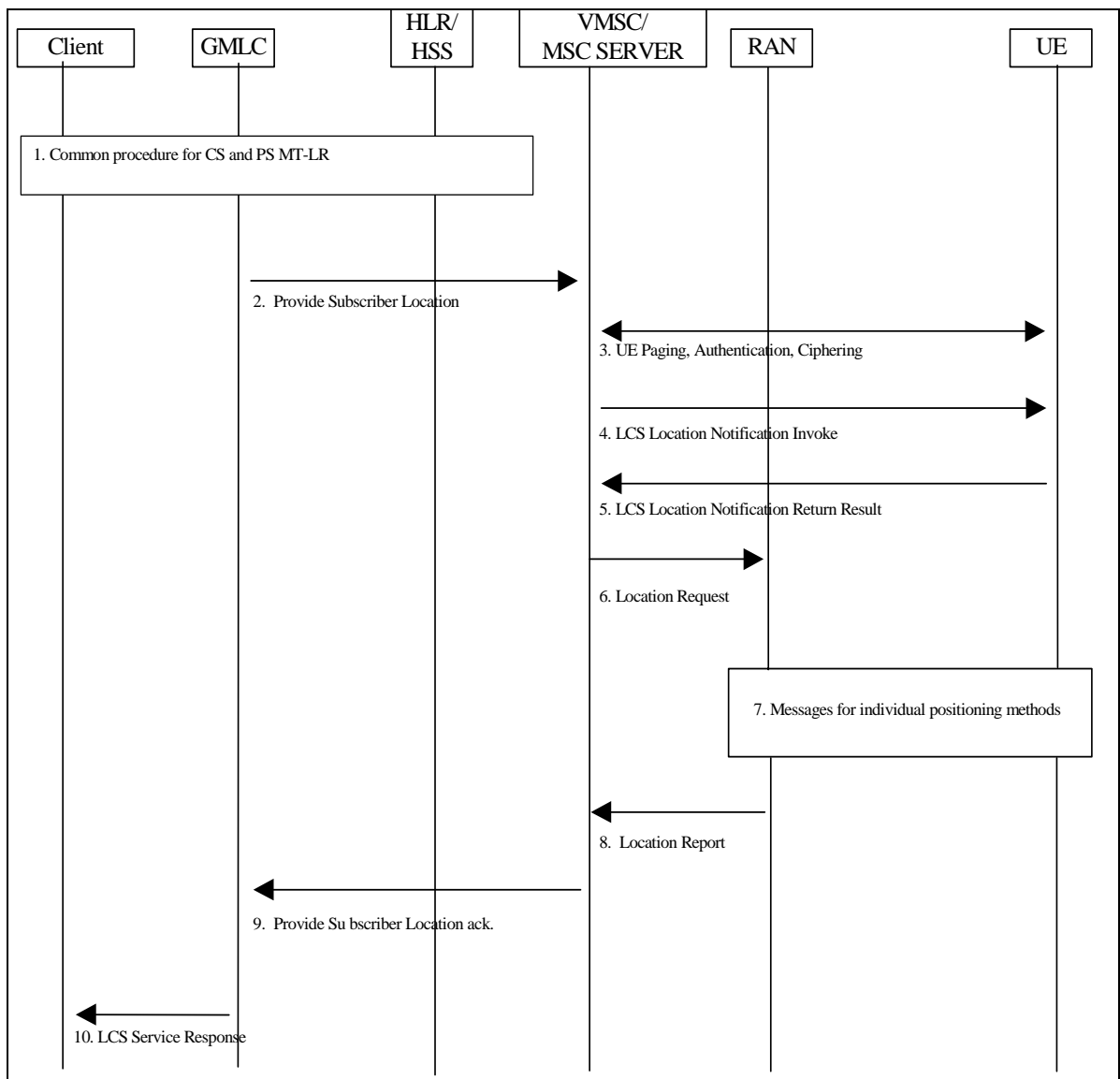

Figure 9.2: Network Positioning for a CS-MT-LR

9.1.2.1 Location Preparation Procedure

- 1) Common PS and CS MT-LR procedure as described in 9.1.1.
- 2) The GMLC sends a PROVIDE_SUBSCRIBER_LOCATION message to the MSC/MSC server indicated by the HLR/HSS. This message carries the type of location information requested (e.g. current location), the UE subscriber’s IMSI, LCS QoS information (e.g. accuracy, response time) and an indication of whether the LCS client has the override capability. For a call related location request, the message also carries the LCS client’s called party number. For a value added LCS client, the message shall carry the client name and the external identity of the LCS client. For a PLMN operator LCS client, the message shall carry the internal identity of the LCS client.
- 3) If the GMLC is located in another PLMN or another country, the VMSC/MSC server first authenticates that a location request is allowed from this PLMN or from this country. If not, an error response is returned. The VMSC/MSC server then verifies LCS barring restrictions in the UE user’s subscription profile in the MSC server. In verifying the barring restrictions, barring of the whole location request is assumed if any part of it is barred or any requisite condition is not satisfied. If LCS is to be barred without notifying the target UE and a LCS client accessing a GMLC in the same country does not have the override capability, an error response is returned to the GMLC. Otherwise, if the UE is in idle mode, the Core Network performs paging, authentication

and ciphering. The UE will inform the network about its LCS capabilities, as described in chapter 6.3.4.. If the UE is instead in dedicated mode, the VMSC/MSC server will already have UE classmark information. In GSM this is supported by controlled early classmark sending.

~~[Note 1: In GSM, LCS: If the target UE has an established circuit call other than speech, the location request may be denied and an error response is then returned to the GMLC. If the location request is allowed for a non-speech circuit call, it shall be up to RAN to decide, on the basis of the applicable position methods and requested QoS, whether positioning is possible. T{this is FFS}]~~

<< next modified section >>

9.1.6.1 Location Preparation Procedure

- 1) Common PS and CS MT-LR procedure as described in 9.1.1.
- 2) GMLC sends a Provide Subscriber Location message to the SGSN indicated by the HLR/HSS. This message carries the type of location information requested (e.g. current location), the UE subscriber's IMSI, LCS QoS information (e.g. accuracy, response time) and an indication of whether the LCS client has the override capability. For a session related location request, the message also carries the APN to which the user has established the session. For a value added LCS client, the message shall carry the client name and the external identity of the LCS client. For a PLMN operator LCS client, the message shall carry the internal identity of the LCS client.
- 3) If the GMLC is located in another PLMN or another country, the SGSN first authenticates that a location request is allowed from this PLMN or from this country. If not, an error response is returned. The SGSN then verifies LCS barring restrictions in the UE user's subscription profile in the SGSN. In verifying the barring restrictions, barring of the whole location request is assumed if any part of it is barred or any requisite condition is not satisfied. If LCS is to be barred without notifying the target UE and a LCS client accessing a GMLC in the same country does not have the override capability, an error response is returned to the GMLC.

Otherwise, if the UE is in idle mode, the SGSN performs paging. The paging procedure is defined in TS 23.060[15].

~~FFS: The UE may be paged for location services even when in UMTS a signaling connection between mobile station and the network is established and in GSM when in Ready Mode. This makes it possible for the UE to start preparing an anticipated location service coming later by e.g. starting to measure GPS signals.~~

<< next modified section >>

9.1.6.2 Positioning Measurement Establishment Procedure

- 8) If the requested location information and the location accuracy within the QoS can be satisfied based on parameters received from the SGSN and the parameters obtained by the RAN e.g. cell coverage and timing information (i.e. RTT ~~or TA~~), the RAN may send a Location Report immediately. Otherwise, the RAN determines the positioning method and instigates the particular message sequence for this method in UTRAN Stage 2 TS 25.305 ~~and in GERAN Stage 2 TS 43.059~~. If the position method returns position measurements, the RAN uses them to compute a location estimate. If there has been a failure to obtain position measurements, the RAN may use the current cell information and, if available, ~~TA or~~ RTT value to derive an approximate location estimate. If an already computed location estimate is returned for an UE based position method, the RAN may verify consistency with the current cell and, if available, ~~RTT or~~ TA value. If the location estimate so obtained does not satisfy the requested accuracy and sufficient response time still remains, the RAN may instigate a further location attempt using the same or a different position method. If a vertical location co-ordinate is requested but the RAN can only obtain horizontal co-ordinates, these may be returned.

<< next modified section>>

9.1.7.1 Positioning Measurement Establishment Procedure

- 2) If the requested location information and the location accuracy within the QoS can be satisfied based on parameters received from the SGSN and the parameters obtained by the RAN e.g. cell coverage and timing information (i.e. ~~TA or~~ RTT), the RAN may send a Location Report immediately. Otherwise, the RAN determines the positioning method and instigates the particular message sequence for this method ~~in TS 43.059~~. If the position method returns position measurements, the RAN uses them to compute a location estimate. If there has been a failure to obtain position measurements, the RAN may use the current cell information and, if available, ~~TA or~~ RTT value to derive an approximate location estimate. If an already computed location estimate is returned for an UE based position method, the RAN may verify consistency with the current cell and, if available, RTT ~~or~~ TA value. If the location estimate so obtained does not satisfy the requested accuracy and sufficient response time still remains, the RAN may instigate a further location attempt using the same or a different position method. If a vertical location co-ordinate is requested but the RAN can only obtain horizontal co-ordinates, these may be returned.

<< next modified section>>

9.2.2.1 Location Preparation Procedure

- 1) In UMTS, if the UE is in idle mode, the UE requests a PS signaling connection and sends a Service request indicating signaling to the SGSN via the RAN. If the UE already has PS signaling connection, the UE does not need to send Service request. Security functions may be executed. These procedures are described in TS 23.060 [15]. ~~In GSM this signaling step is not needed.~~

<< next modified section>>

9.2.2.2 Positioning Measurement Establishment Procedure

- 4) If the UE is requesting its own location, the actions described in ~~UTRAN Stage 2, TS 25.305 [1] or GERAN stage 2 TS 43.059 [16]~~ are performed. If the UE is instead requesting location assistance data, the RAN transfers this data to the UE as described in subsequent clauses. The RAN determines the exact location assistance data to transfer according to the type of data specified by the UE, the UE location capabilities and the current cell.

<< next modified section>>

9.4.3 Procedures in the 3G-SGSN

After the SGSN has requested a location service for a particular UE from RAN, certain events may occur that may temporarily or permanently interfere with the location service attempt. For each such event notified to the SGSN, the SGSN shall employ one of the following error recovery actions.

Restart the Location Service

This action shall be employed for any event that temporarily impedes a location service attempt and cannot be delayed until the location service attempt is complete. When such an event is notified to the SGSN, it shall immediately cancel the location service attempt and the associated signaling dialogue with RAN, if this still exists by sending a "stop reporting" message to RAN. The "stop reporting" message shall contain the reason for the location procedure cancellation.

After aborting the location request dialogue with RAN, the SGSN may queue the location service request until the event causing the restart has terminated (if not already terminated). The SGSN may optionally wait for an additional time period (e.g. if the queuing delay is minimal) to ensure that any resources allocated in and by RAN have time to be released. The SGSN may then send another location service request to RAN associated with the target UE.

Abort the Location Service

This action shall be employed for any event that permanently impedes a location service attempt, such as loss of the radio channel to the target UE. When such an event is notified to the SGSN, it shall cancel the current location service attempt and the associated signaling dialogue with RAN, if still existing, by sending a "stop reporting" message to RAN. The "stop reporting" message shall contain the reason for the location procedure cancellation. The SGSN shall then return an error response to the client or network entity from which the location request was originally received. The SGSN shall also release all resources specifically allocated for the location attempt.

The following table indicates the appropriate error recovery procedure for certain events. For events not listed in the table, the SGSN need take no action.

Table 9.2: LCS Error Recovery Procedures in the SGSN for certain Events

Event	SGSN Error Recovery
Release of radio channel to the UE	Abort
Any error response from RAN causing unavailable signalling connections	Abort
SRNC relocation (UMTS only)	[Note: This is being discussed in RAN WG2 and RAN WG3.]
Suspend of GPRS services (GSM only) (During CS connection for class B UE)	Abort

3GPP TSG- SA WG2 (LCS drafting)
Puerto Rico, 14.-18.5.2001

Tdoc S2-011510
 (Revised S2-011282)

CR-Form-v3

CHANGE REQUEST

⌘ **23.271 CR 23** ⌘ rev **1** ⌘ Current version: **4.1.0** ⌘

For **HELP** on using this form, see bottom of this page or look at the pop-up text over the ⌘ symbols.

Proposed change affects: ⌘ (U)SIM ME/UE Radio Access Network Core Network

Title:	⌘ Completion of changes regarding UE LCS capabilities		
Source:	⌘ Nokia		
Work item code:	⌘ LCS1	Date:	⌘ 7.5.2001
Category:	⌘ D	Release:	⌘ REL-4
	Use <u>one</u> of the following categories: F (essential correction) A (corresponds to a correction in an earlier release) B (Addition of feature), C (Functional modification of feature) D (Editorial modification) Detailed explanations of the above categories can be found in 3GPP TR 21.900.		Use <u>one</u> of the following releases: 2 (GSM Phase 2) R96 (Release 1996) R97 (Release 1997) R98 (Release 1998) R99 (Release 1999) REL-4 (Release 4) REL-5 (Release 5)

Reason for change:	⌘ Completion of changes on UE location capabilities in UMTS		
Summary of change:	⌘ References to UE's location capabilities removed in UMTS parts of the document		
Consequences if not approved:	⌘ Ambiguous requirements within 23.271.		

Clauses affected:	⌘		
Other specs affected:	<input type="checkbox"/> Other core specifications <input type="checkbox"/> Test specifications <input type="checkbox"/> O&M Specifications	⌘	
Other comments:	⌘		

How to create CRs using this form:

Comprehensive information and tips about how to create CRs can be found at: http://www.3gpp.org/3G_Specs/CRs.htm. Below is a brief summary:

- 1) Fill out the above form. The symbols above marked ⌘ contain pop-up help information about the field that they are closest to.
- 2) Obtain the latest version for the release of the specification to which the change is proposed. Use the MS Word "revision marks" feature (also known as "track changes") when making the changes. All 3GPP specifications can be downloaded from the 3GPP server under <ftp://www.3gpp.org/specs/> For the latest version, look for the directory name with the latest date e.g. 2000-09 contains the specifications resulting from the September 2000 TSG meetings.
- 3) With "track changes" disabled, paste the entire CR form (use CTRL-A to select it) into the specification just in front of the clause containing the first piece of changed text. Delete those parts of the specification which are not relevant to the change request.

<< first modified section >>

9.1.2.1 Location Preparation Procedure

- 1) Common PS and CS MT-LR procedure as described in 9.1.1.
- 2) The GMLC sends a PROVIDE_ SUBSCRIBER_ LOCATION message to the MSC/MSC server indicated by the HLR/HSS. This message carries the type of location information requested (e.g. current location), the UE subscriber's IMSI, LCS QoS information (e.g. accuracy, response time) and an indication of whether the LCS client has the override capability. For a call related location request, the message also carries the LCS client's called party number. For a value added LCS client, the message shall carry the client name and the external identity of the LCS client. For a PLMN operator LCS client, the message shall carry the internal identity of the LCS client.
- 3) If the GMLC is located in another PLMN or another country, the VMSC/MSC server first authenticates that a location request is allowed from this PLMN or from this country. If not, an error response is returned. The VMSC/MSC server then verifies LCS barring restrictions in the UE user's subscription profile in the MSC server. In verifying the barring restrictions, barring of the whole location request is assumed if any part of it is barred or any requisite condition is not satisfied. If LCS is to be barred without notifying the target UE and a LCS client accessing a GMLC in the same country does not have the override capability, an error response is returned to the GMLC. Otherwise, if the UE is in idle mode, the Core Network performs paging, authentication and ciphering. The UE will inform the network about its LCS capabilities, as described in chapter 6.3.4.. If the UE is instead in dedicated mode, the VMSC/MSC server will already have UE classmark information. In GSM this is supported by controlled early classmark sending.

[GSM LCS: If the target UE has an established circuit call other than speech, the location request may be denied and an error response is then returned to the GMLC. If the location request is allowed for a non-speech circuit call, it shall be up to RAN to decide, on the basis of the applicable position methods and requested QoS, whether positioning is possible. [this is FFS]]

- 4) If the location request comes from a value added LCS client and the UE subscription profile indicates that the UE must either be notified or notified with privacy verification and the UE supports notification of LCS (according to the UE Capability information), an LCS Location Notification Invoke message is sent to the target UE indicating the type of location request (e.g. current location) and the identity of the LCS client and whether privacy verification is required. [FFS: For a call related location request, the LCS client identity shall be set to the LCS client's called party number if no separate LCS client identity was received from the GMLC.] Optionally, the VMSC/MSC server may after sending the LCS Location Notification Invoke message continue in parallel the location process, i.e. continue to step 6 without waiting for a LCS Location Notification Return Result message in step 5.

NOTE 2: This step is for further study, it should be investigated e.g. which client identities to include in the Privacy Notification message to be shown to the end-user.

- 5) The target UE notifies the UE user of the location request. If privacy verification was requested, the target UE indicates to the UE user whether the location request will be allowed or not allowed in the absence of a response and waits for the user to grant or withhold permission. The UE then returns an LCS Location Notification Return Result to the VMSC/MSC server indicating, if privacy verification was requested, whether permission is granted or denied. Optionally, the LCS Location Notification Return Result message can be returned some time after step 4, but before step 9. If the UE user does not respond after a predetermined time period, the VMSC/MSC server shall infer a "no response" condition. The VMSC/MSC server shall return an error response to the GMLC if privacy verification was requested and either the UE user denies permission or there is no response with the UE subscription profile indicating barring of the location request in the absence of a response.
- 6) The MSC/MSC server sends a Location Request message to RAN. This message includes the type of location information requested, ~~the UE's location capabilities~~ and requested QoS and, in GSM, the UE's location capabilities.

<< next modified section >>

9.1.6.1 Location Preparation Procedure

- 1) Common PS and CS MT-LR procedure as described in 9.1.1.
- 2) GMLC sends a Provide Subscriber Location message to the SGSN indicated by the HLR/HSS. This message carries the type of location information requested (e.g. current location), the UE subscriber's IMSI, LCS QoS information (e.g. accuracy, response time) and an indication of whether the LCS client has the override capability. For a session related location request, the message also carries the APN to which the user has established the session. For a value added LCS client, the message shall carry the client name and the external identity of the LCS client. For a PLMN operator LCS client, the message shall carry the internal identity of the LCS client.
- 3) If the GMLC is located in another PLMN or another country, the SGSN first authenticates that a location request is allowed from this PLMN or from this country. If not, an error response is returned. The SGSN then verifies LCS barring restrictions in the UE user's subscription profile in the SGSN. In verifying the barring restrictions, barring of the whole location request is assumed if any part of it is barred or any requisite condition is not satisfied. If LCS is to be barred without notifying the target UE and a LCS client accessing a GMLC in the same country does not have the override capability, an error response is returned to the GMLC. Otherwise, if the UE is in idle mode, the SGSN performs paging. The paging procedure is defined in TS 23.060[15].

FFS: The UE may be paged for location services even when in UMTS a signaling connection between mobile station and the network is established and in GSM when in Ready Mode. This makes it possible for the UE to start preparing an anticipated location service coming later by e.g. starting to measure GPS signals.

- 4) Security functions may be executed. These procedures are defined in TS 23.060 [**Error! Reference source not found.**].
- 5) If the location request comes from a value added LCS client and the UE subscription profile indicates that the UE must either be notified or notified with privacy verification and the UE supports notification of LCS, a notification invoke message is sent to the target UE indicating the type of location request (e.g. current location) and the identity of the LCS client and whether privacy verification is required. Optionally, the SGSN may after sending the LCS Location Notification Invoke message continue in parallel the location process, i.e. continue to step 7 without waiting for a LCS Location Notification Return Result message in step 6.
- 6) The target UE notifies the UE user of the location request and, if privacy verification was requested, waits for the user to grant or withhold permission. The UE then returns a notification result to the SGSN indicating, if privacy verification was requested, whether permission is granted or denied. Optionally, this message can be returned some time after step 5, but before step 10. If the UE user does not respond after a predetermined time period, the SGSN shall infer a "no response" condition. The SGSN shall return an error response to the GMLC if privacy verification was requested and either the UE user denies permission or there is no response with the UE subscription profile indicating barring of the location request.
- 7) The SGSN sends a Location Request message to the RAN. This message includes the type of location information requested, ~~the UE's location capabilities~~, the requested QoS and any other location information received in paging response.

<< next modified section >>

9.1.7 Packet Switched Network Induced Location Request (PS-NI-LR)

Figure 9.6 illustrates a network induced location request from the SGSN. This procedure may be used e.g. for positioning of an emergency call.

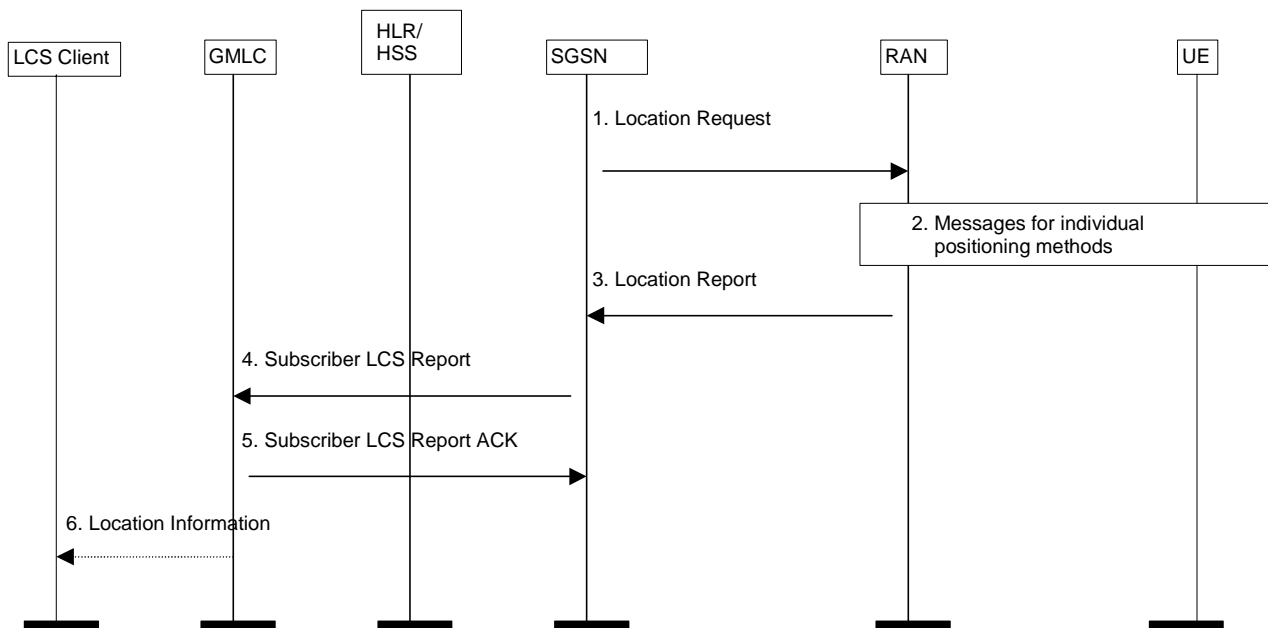

Figure 9.6: Network Induced Location Request

- 1) The SGSN sends a Location Request message to the RAN. This message indicates the type of location information requested, the UE's location capabilities and requested QoS.

<< next modified section >>

9.2.1.1 Location Preparation Procedure

- 1) If the UE is in idle mode, the UE requests a radio connection setup and sends a CM service request indicating a request for a call independent supplementary services to the VMSC/MSC server via RAN.
- 2) RAN shall convey the CM service request to the core network. If the UE is in dedicated mode, the UE sends a CM Service Request on the already established radio connection.
- 3) The VMSC/MSC server instigates authentication and ciphering if the UE was in idle mode or returns a Direct Transfer CM Service Accept if the UE was in dedicated mode. The UE will inform the network about its LCS capabilities, as described in chapter 6.3.4.
- 4) The UE sends a LCS CS-MO-LR Location Services invoke to the VMSC/MSC server. If the UE is requesting its own location or that its own location be sent to another LCS client, this message carries LCS requested QoS information (e.g. accuracy, response time). If the UE is requesting that its location be sent to another LCS client, the message shall include the identity of the LCS client and may include the address of the GMLC through which the LCS client should be accessed. If a GMLC address is not included, the VMSC/MSC server may assign its own GMLC address and may verify that the identified LCS client is supported by this GMLC. If a GMLC address is not available for this case, the VMSC/MSC server shall reject the location request. If the UE is instead requesting location assistance data or ciphering keys, the message specifies the type of assistance data or deciphering keys and the positioning method for which the assistance data or ciphering applies. The VMSC/MSC server verifies in the UE's subscription profile that the UE has permission to request its own location, request that its location be sent to another LCS client or request location assistance data or deciphering keys (whichever applies). If the UE is requesting positioning and has an established call, the VMSC/MSC server may reject the request for certain non-speech call types.
- 5) The VMSC/MSC server sends a Location Request message to RAN associated with the Target UE. The message indicates whether a location estimate or location assistance data is requested and, in GSM, includes the UE's location capabilities. If the UE's location is requested, the message also includes the requested QoS. If location assistance data is requested, the message carries the requested types of location assistance data.

<< next modified section>>

9.2.2.1 Location Preparation Procedure

- 1) In UMTS, if the UE is in idle mode, the UE requests a PS signaling connection and sends a Service request indicating signaling to the SGSN via the RAN. If the UE already has PS signaling connection, the UE does not need to send Service request. Security functions may be executed. These procedures are described in TS 23.060 [15]. In GSM this signaling step is not needed.
- 2) The mobile station sends a service invoke message to the SGSN. Different types of location services can be requested: location of the UE, location of the UE to be sent to another LCS client, location assistance data or ciphering keys. If the UE is requesting its own location or that its own location be sent to another LCS client, this message carries LCS requested QoS information (e.g. accuracy, response time). If the UE is requesting that its location be sent to another LCS client, the message shall include the identity of the LCS client and may include the address of the GMLC through which the LCS client should be accessed. If a GMLC address is not included, the SGSN may assign its own GMLC address and may verify that the identified LCS client is supported by this GMLC. If a GMLC address is not available for this case, the SGSN shall reject the location request. If the UE is instead requesting location assistance data or ciphering keys, the message specifies the type of assistance data or deciphering keys and the positioning method for which the assistance data or ciphering applies. The SGSN verifies the subscription profile of the UE and decides if the requested service is allowed or not.
- 3) The SGSN sends a Location Request message to the RAN associated with the Target UE's location. The message indicates whether a location estimate or location assistance data is requested and includes the UE's location capabilities. If the UE's location is requested, the message also includes the requested QoS. If location assistance data is requested, the message carries the requested types of location assistance data. The message carries also location parameters received in the Service Invoke message.

(S2-011508)

(S2-011497)

(S2-011432)

(S2-011345)

CR-Form-v3

CHANGE REQUEST

⌘ **23.271 CR 026** ⌘ rev **4** ⌘ Current version: **4.1.0** ⌘

For **HELP** on using this form, see bottom of this page or look at the pop-up text over the ⌘ symbols.

Proposed change affects: ⌘ (U)SIM ME/UE Radio Access Network Core Network

Title:	⌘ Re-attempt of location request when MS becomes reachable.		
Source:	⌘ Ericsson, Fujitsu, Siemens		
Work item code:	⌘ LCS1	Date:	⌘ 2001-05-17
Category:	⌘ B	Release:	⌘ Rel4
Use <u>one</u> of the following categories: F (essential correction) A (corresponds to a correction in an earlier release) B (Addition of feature), C (Functional modification of feature) D (Editorial modification) Detailed explanations of the above categories can be found in 3GPP TR 21.900.		Use <u>one</u> of the following releases: 2 (GSM Phase 2) R96 (Release 1996) R97 (Release 1997) R98 (Release 1998) R99 (Release 1999) REL-4 (Release 4) REL-5 (Release 5)	

Reason for change:	⌘ The following requirement from stage 1 is not solved in current stage 2 specification: " If a positioning attempt fails, the LCS server may make another positioning attempt. This attempt should be made when the target MS can be detected by the network. It may be possible for the LCS client to set this action as an option."
Summary of change:	⌘ Since the provision of location when MS becomes available requires some of the same handling in the network as the deferred event driven location request, the above requirement can be fulfilled by introducing parts of the Deferred Location Request functionality. This CR proposes the following additions to the existing functionality: <ul style="list-style-type: none"> - If case the LCS Client have requested that in case the positioning attempt fails the LCS Server shall make another positioning attempt when the target MS can be detected by the network, the GMLC shall be able to initiate a deferred location request with event "MS available" against SGSN/MSC. - The SGSN/MSC shall be able to return location report to GMLC when available.
Consequences if	⌘ Stage one requirement will not be fulfilled.

not approved:

Clauses affected:	⌘	4.4, 9.1.1, 9.1.8(new), ANNEX C		
Other specs Affected:	⌘	<input checked="" type="checkbox"/> Other core specifications	⌘	29.002
		<input type="checkbox"/> Test specifications		
		<input type="checkbox"/> O&M Specifications		
Other comments:	⌘			

How to create CRs using this form:

Comprehensive information and tips about how to create CRs can be found at: http://www.3gpp.org/3G_Specs/CRs.htm. Below is a brief summary:

- 1) Fill out the above form. The symbols above marked ⌘ contain pop-up help information about the field that they are closest to.
- 2) Obtain the latest version for the release of the specification to which the change is proposed. Use the MS Word "revision marks" feature (also known as "track changes") when making the changes. All 3GPP specifications can be downloaded from the 3GPP server under <ftp://www.3gpp.org/specs/> For the latest version, look for the directory name with the latest date e.g. 2000-09 contains the specifications resulting from the September 2000 TSG meetings.
- 3) With "track changes" disabled, paste the entire CR form (use CTRL-A to select it) into the specification just in front of the clause containing the first piece of changed text. Delete those parts of the specification which are not relevant to the change request.

4.4 Types of Location Request

4.4.1 Immediate Location Request

Request for location where the MSC/SGSN replies immediately to the GMLC with the current location estimate if this could be obtained.

4.4.2 Deferred Location Request

Request for location contingent on some current or future events where the response from the MSC/SGSN to the GMLC may occur some time after the request was sent.

4.4.2.1 Types of event

- a) UE available: Any event in which radio contact is established with the UE when not in IMSI detached mode. Note, this event is considered to be applicable when the UE is temporarily unavailable due to inaction by the UE user or temporarily loss of radio connectivity
- b) Other events are FFS (Release 5)

9.1 Mobile Terminating Location Request

9.1.1 MT-LR routing procedure in PS and CS domain

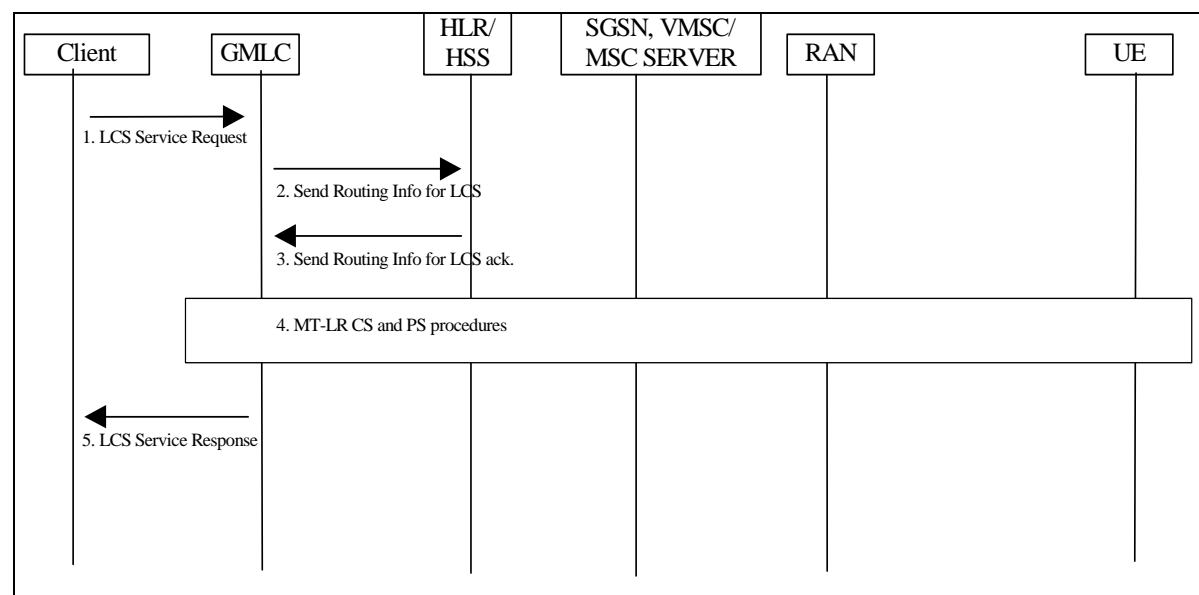

Figure 9.1: General Network Positioning for a MT-LR

- 1) An external LCS client requests the current location of a target UE from a GMLC. The LCS Client may also request a deferred location request, i.e. based on event. The GMLC verifies the identity of the LCS client and its subscription to the LCS service requested and derives the MSISDN or IMSI or PDP address, (NOTE: IP addressing in this context is FFS, one reason is the dynamic IP addressing used in IPv4.) of the target UE to be located and the LCS QoS from either subscription data or data supplied by the LCS client. For a call related or session related location request, the GMLC obtains and authenticates the called party number of the LCS client. If location is required for more than one UE, or if periodic location is requested, the

steps following below may be repeated.

Note: This means that GMLC handles the periodicity of location requests as requested by the LCS client both in CS and PS domain.

- 2) If the GMLC already knows both the VMSC/MSC server or SGSN location and IMSI for the particular MSISDN or PDP address, (e.g. from a previous location request), this step and step 3 may be skipped. Otherwise, the GMLC sends a SEND_ROUTING_INFO_FOR_LCS message to the home HLR/HSS of the target UE to be located with the IMSI, PDP address or MSISDN of this UE.
- 3) The HLR/HSS verifies that the calling party SCCP address of the GMLC corresponds to a known GSM/UMTS network element that is authorized to request UE location information. The HLR/HSS then returns one or several of the addresses, the current SGSN and/or VMSC/MSC server and whichever of the IMSI and MSISDN was not provided in step (2) for the particular UE.

Note: HLR may prioritize between the MSC/VLR or SGSN address sent to GMLC. The priority criteria are for further study.

- 4) In case GMLC receives only the MSC/VLR address, the MT LR proceeds as the CS-MT-LR procedure described in 9.1.2. In case GMLC receives only the SGSN address, the MT LR proceeds as the PS-MT-LR procedure described in 9.1.6. In case the GMLC receives several of the following addresses, SGSN, VMSC and/or MSC Server, it has to decide where to send the location request. If the requested MT-LR is known to be associated with a CS call, the CS-MT-LR procedure shall be invoked. If the requested MT-LR is associated with a PS session, the PS-MT-LR procedure only shall be invoked. Otherwise, both CS-MT-LR and PS-MT-LR are applicable. If LCS Client indicated deferred location request, GMLC shall indicate this together with applicable event type (ex. MS available) in requested PS/CS-MT-LR, see 9.1.8.

NOTE: The order in which these procedures are invoked and whether one or both procedures are used may depend on subscription information for the LCS client, possible priority information returned by the HSS or information already stored in the GMLC (e.g. obtained from previous location requests).

- 5) GMLC sends the location service response to the LCS client. If the LCS client requires it, the GMLC may first transform the universal location co-ordinates provided by the SGSN or MSC/MSC server into some local geographic system. The GMLC may record billing for both the LCS client and inter-network revenue charges from the SGSN or MSC/MSC server's network.

The detailed CS-MT-LR and PS-MT-LR procedures in step 4 of figure 9.1 are described in 9.1.2 and 9.1.6.

The detailed procedure for deferred PS/CS-MT-LR is described in 9.1.8.

***** *NEXT MODIFICATION* *****

9.1.8 Mobile Terminating Deferred Location Request

Figure 9.x illustrates the procedures for a Deferred Location Request, where the Location Report is returned based on a event.

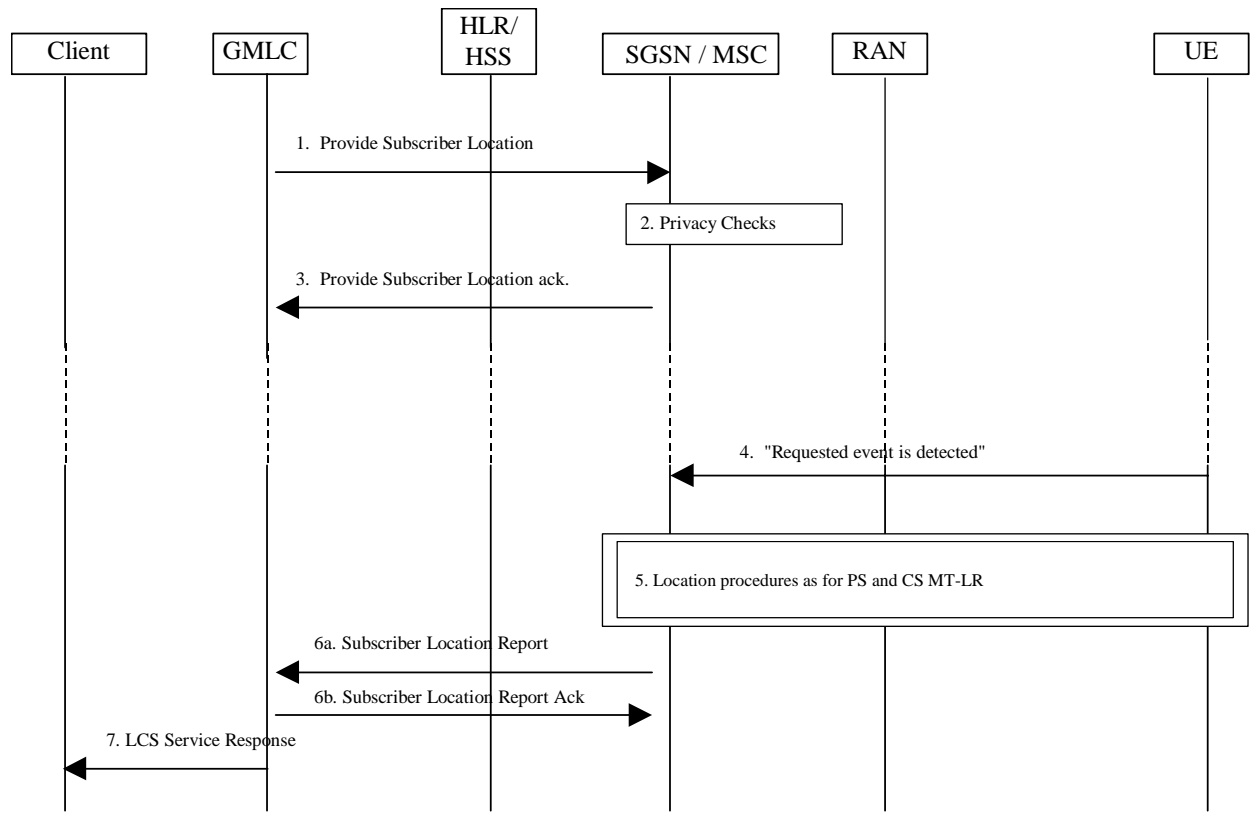

Figure 9.x: General Network Positioning for a Deferred MT-LR

9.1.8.1 Deferred Location Request Procedure

- 1) Provide Subscriber Location is received in SGSN/MSC as described in 9.1.2/9.1.6. In addition, the Deferred Location Request includes the event that shall trigger the sending of Location Report.
- 2) If the SGSN/MSC cannot support the deferred location request for the specified event (for temporary or permanent reasons), a Provide Subscriber Location return error shall be returned in step 3 with a suitable cause. The SGSN/MSC verifies that the LCS client is allowed to position the requested UE according to subscription information (no interaction at this stage with the UE). If not, a Provide Subscriber Location return error is returned in step 3.
- 3) If the SGSN/MSC can support the deferred location request for the specified event and the privacy checks in step 2 are satisfied, a Provide Subscriber Location ack. shall be returned to the GMLC without a location estimate. The GMLC will at this stage not return any response to the LCS Client. It will instead due to the Deferred Location Request wait for a Subscriber Location Report message from SGSN/MSC.

9.1.8.2 Location Report Procedure

- 4) Immediately following step 3, the SGSN/MSC shall verify if the requested event is already satisfied (e.g. UE available inferred from a current transaction) or can be invoked immediately (e.g. by paging the UE and receiving a page response). If requested event is not existing the SGSN/MSC waits until it has occurred or until some maximum time has expired.

Annex C (informative – under study): UE Presence Notification

The context in this annex has been reviewed and currently under study by SA2. This text may be moved to the main body or deleted according to the feedback from SA1 on the underlying requirement.

Note: — The section number in this annex is not consistent since it was originally intended to be included in the main body.

9.8 UE Presence Notification

9.8.1 MT-LR routing procedure

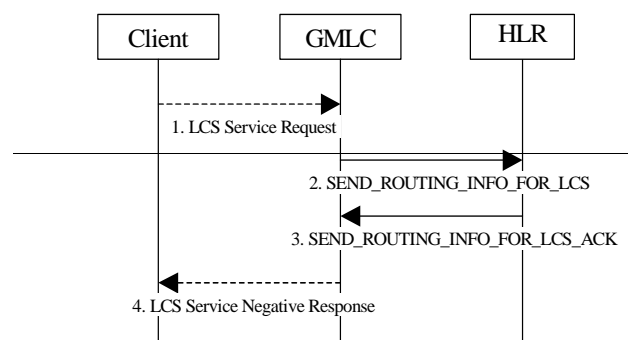

Figure 9.x: MT-LR routing procedure

9.8.1.1 HLR

When the HLR receives the SEND_ROUTING_INFO_FOR_LCS message from the GMLC, it checks if the routing information (i.e., MSC number and/or SGSN number) is stored for the mobile subscriber and the mobile subscriber is reachable either via CS domain or PS domain based on the status of the “MSC Area Restricted Flag” and the “UE purged for non GPRS” for CS domain, and “SGSN Area Restricted Flag” and “UE purged for GPRS” for PS domain.

If no routing information is stored for the mobile subscriber or the mobile subscriber is not reachable based on the flags listed above, the mobile station not reachable flags for the appropriate domain (i.e., MNRF and/or MNRG) are set and the “Absent Subscriber” error is returned with the appropriate absent subscriber diagnostic indication, i.e., “Deregistered in HLR for non GPRS”, “Deregistered in HLR for GPRS”, “Roaming Restricted”, “Roaming Restricted for GPRS”, “UE Purged for non GPRS” or “UE Purged for GPRS”. The LCS client ID and the GMLC number are included in the MWD if the GMLC support the UE presence notification procedure. The HLR knows that the GMLC supports the UE presence notification procedure receiving the LCS Client ID in the SEND_ROUTING_INFO_FOR_LCS message.

The HLR returns the routing information (i.e., MSC number and/or SGSN number) if available irrelevant to the status of the mobile station not reachable flags.

- i) Routing information is available in either domain

The available routing information is set to the SEND_ROUTING_INFO_FOR_LCS_ACK and returned to the GMLC.

- ii) Routing information is NOT available in both domains

The “Absent Subscriber” error is returned to the GMLC with the appropriate absent subscriber diagnostic indication which is derived from the mobile not reachable reason (MNRR), and the mobile station not reachable flag(s) for the appropriate domain is set.

If the UE presence notification procedure is supported by the GMLC, following procedure shall be applied:

The HLR includes the LCS MWD Status, which shows the status of the MNRF, the MNRG and the contents of MNRR, in the every SEND_ROUTING_INFO_FOR_LCS_ACK message to indicate the status of the MWD in the HLR, and its support of the UE presence notification procedure to the GMLC.

The HLR also set the indication to the SEND_ROUTING_INFO_FOR_LCS_ACK message whether or not the LCS Client ID is already included in the MWD.

9.8.1.2 GMLC

Receiving the SEND_ROUTING_INFO_FOR_LCS_ACK message from the HLR, the GMLC proceeds with the MT-LR based on the received routing information and LCS MWD status (if available).

The detail logics of the GMLC regarding how the routing to be proceeded with are left to the implementation, however possible points to be considered are, for example,

- which domain is selected first considering the LCS MWD status,
- if the GMLC proceeds with the MT-LR to a domain whose not reachable flag is set and the MNRR indicating “No Paging Response”,
- if the LCS priority is taken into account for the decision of above, and
- if the GMLC retries in the other domain or abort of the MT-LR when first trail has failed.

9.8.2 LCS client alerting procedure

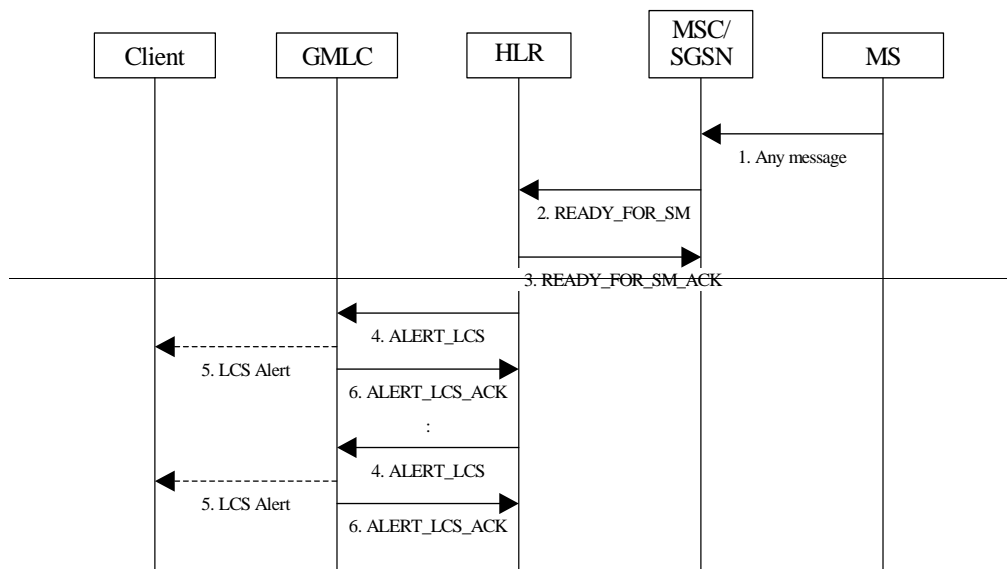

Figure 9.y: LCS Client Alerting procedure

9.8.2.1 MSC/SGSN

When detecting that the mobile subscriber becomes reachable while the MNRF or the MNRG is set, the MSC or the SGSN will send the `READY_FOR_SM` message towards the HLR. The Alert Reason is set to indicate that the mobile subscriber is present.

When receiving the answer, the MSC or the SGSN will act as follows:

- MNRF or MNRG is cleared if the procedure is successful
- MNRF or MNRG is NOT cleared if the procedure is not successful

9.8.2.2 HLR

Depending on the received message (e.g., `READY_FOR_SM`, `UPDATE_LOCATION`, `UPDATE_GPRS_LOCATION`), the HLR updates the status of the appropriate mobile station not reachable flag, and initiates the LCS client alerting procedure if necessary. This logic to initiate the alerting procedure is almost same as what is defined in the SMS except that the LCS is not relevant to the alerting reason about memory becoming available in the mobile equipment. For detail, refer to TS 23.040 [x] and TS 29.002 [y].

If the HLR determines to initiate the LCS client alerting procedure, all the GMLCs that are set to the MWD are sent the `ALERT_LCS` messages to inform the mobile subscriber become reachable. The `ALERT_LCS` message includes the list of the LCS Client IDs that are associated with the GMLC.

When receiving the answer to the `ALERT_LCS` message, the HLR will clear the GMLC number and the associated LCS Client IDs in the MWD.

9.8.2.3 GMLC

When the `ALERT_LCS` message is correctly received by the GMLC, the GMLC will forward the alerting to the given LCS clients specified in the received message.

9.9.3 LCS status reporting procedure

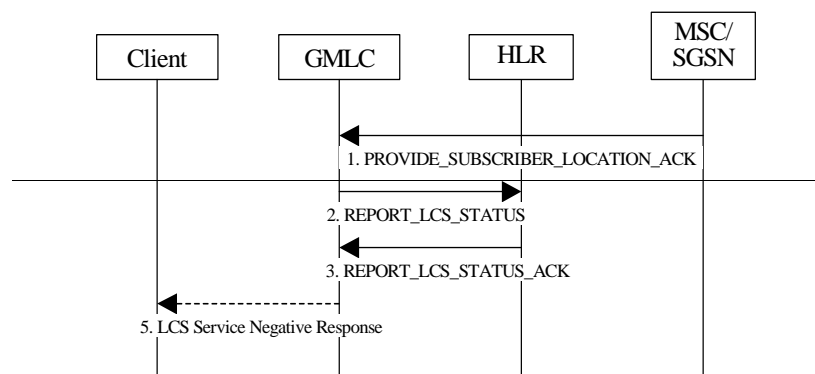

Figure 9.z: UE Presence Notification procedure

9.8.3.1 MSC/SGSN

Receiving the `PROVIDE_SUBSCRIBER_LOCATION` message, the MSC or the SGSN initiates an appropriate procedure for the MT-LR.

If the MT-LR fails because the mobile subscriber is not reachable, the MSC or the SGSN shall set the mobile station not reachable flag. The “Absent Subscriber” error is returned to the GMLC with the appropriate absent subscriber diagnostic indication.

Note: — The support of the UE presence notification procedure for LCS in the MSC and the SGSN is mandatory.

9.8.3.2 — GMLC

The GMLC recognized that the HLR supports the UE presence notification procedure receiving the LCS MWD Status in the SEND_ROUTING_INFO_FOR_LCS_ACK message. If the HLR does not support the UE presence notification procedure, the GMLC does not initiate the LCS status reporting procedure to the HLR.

If the GMLC does not have the LCS MWD Status since it did not execute the send routing information for LCS procedure and the GMLC is not sure that the HLR does not support the UE presence notification procedure for LCS, the GMLC shall always initiate the LCS status reporting procedure.

The conditions that the GMLC needs to initiate the LCS status reporting procedure when the HLR supports the UE presence notification procedure and the send routing information for LCS procedure has been executed are left for implementation. The GMLC can initiate the procedure always, or if only necessary. The minimum conditions to initiate the procedure are as follows:

- a) Either of the MNRF or the MNRG is not set in the HLR, and the MT-LR fails for the domain because of the mobile subscriber not reachable.
- b) The MT-LR has succeeded for a domain while the not reachable flag for the domain is set in the HLR.
- c) The reason set in the MNRR for a domain is not same as one newly received from the domain.
- d) The LCS client is not set in the MWD when the MT-LR fails for the domain because of the mobile subscriber not reachable.

Note: — The failure of the MT-LR in above includes two cases. One is the case that PROVIDE_SUBSCRIBER_LOCATION message has been sent and negative response is received, and another case is that the MT-LR is aborted before sending the message because of the status of the MNRF or MNRG.

If the GMLC determines that it is necessary to update the MWD in the HLR, it sends the REPORT_LCS_STATUS message to the HLR that includes the new status of the either or both of the MNRF and the MNRG with the network node number (i.e., the MSC number or the SGSN number) that returned the error response. If the GMLC has received the diagnostic information with “Absent Subscriber” error, it is forwarded to the HLR as well.

If the LCS client ID cannot be inserted to the MWD in the HLR by any reason, the GMLC may inform the LCS client that it cannot expect the report when the mobile subscriber becomes reachable.

9.8.3.3 — HLR

The HLR receives the REPORT_LCS_STATUS message from the GMLC.

If the corresponded MSC is earlier than LCS phase 2, the MNRF shall not be newly set in the HLR. In this case, the LCS Client ID cannot be inserted to the MWD unless either the MNRF or the MNRG has been already set. Otherwise if the inclusion of the GMLC number and/or LCS Client ID in the MWD is not possible, “Feature not supported by the serving node” error is returned.

If the MT-LR Outcome reports unsuccessful execution, the network node number received in the REPORT_LCS_STATUS message is same as the current serving node number stored in the HLR for the corresponding domain, and the message waiting list is not full, the given LCS Client ID is inserted and an acknowledgement is sent to the GMLC. Otherwise if the inclusion of the GMLC number and/or LCS Client ID in the MWD is not possible, a message waiting list full error is returned to the GMLC, or if the serving node numbers are not same, a “Serving Node Number Mismatch” error is returned to the GMLC.

If the MT-LR Outcome is absent subscriber for non-GPRS, the HLR sets the mobile station not reachable flag in the subscriber data. If a reason for absence is provided by the GMLC then this is stored in the mobile station not reachable reason (MNRR) in the subscriber data.

If the MT-LR Outcome is absent subscriber for GPRS, the HLR sets the mobile station not reachable for GPRS flag in the subscriber data. If a reason for absence is provided by the GMLC then this is stored in the mobile station not reachable reason (MNRR) in the subscriber data.