

Technical Specification Group Services and System Aspects ***TSGS#12(01)0337***
Meeting #12, Stockholm, Sweden, 18-21 June 2001

Source: TSG SA WG2
Title: Cover page for **23.207 version 2.0.0**
Agenda Item: 7.2.3

This version incorporates all the S2 achievements for End-to-End QoS agreements up to and including SA2#18 in Puerto Rico, USA (May 2001) plus some editorial clean ups approved by e-mail.

SA2 now judges the TS is 80% stable and then asks TSG SA to approve to raise it to version 5.0.0.

3G TS 23.207 V2.0.0 (2001-06)

Technical Specification

3rd Generation Partnership Project; Technical Specification Group Services and System Aspects; End-to-End QoS Concept and Architecture



The present document has been developed within the 3rd Generation Partnership Project (3GPPTM) and may be further elaborated for the purposes of 3GPP.

The present document has not been subject to any approval process by the 3GPP Organisational Partners and shall not be implemented. This Specification is provided for future development work within 3GPP only. The Organisational Partners accept no liability for any use of this Specification. Specifications and reports for implementation of the 3GPPTM system should be obtained via the 3GPP Organisational Partners' Publications Offices.

Keywords

<keyword[, keyword]>

3GPP

Postal address

3GPP support office address

650 Route des Lucioles - Sophia Antipolis
Valbonne - FRANCE
Tel.: +33 4 92 94 42 00 Fax: +33 4 93 65 47 16

Internet

<http://www.3gpp.org>

Copyright Notification

No part may be reproduced except as authorized by written permission.
The copyright and the foregoing restriction extend to reproduction in all media.

© 2000, 3GPP Organizational Partners (ARIB, CWTS, ETSI, T1, TTA, TTC).
All rights reserved.

09/21/00 7:00 PM

Contents

Foreword.....	5
1 Scope	6
2 References	6
3 Definitions and Abbreviations.....	7
3.1 Definitions	7
3.2 Abbreviations	8
4 High Level Requirements for End-to-End IP QoS.....	8
4.1 End-to-End QoS Negotiation Requirements.....	8
4.2 QoS Policy Requirements.....	9
5 End-to-End QoS Architecture	9
5.1 QoS Management Functions in the Network.....	9
5.1.1 Description of functions.....	10
5.1.1.1 QoS management functions for end-to-end IP QoS in UMTS Network	10
5.1.1.2 IP BS Manager Functionality in the GGSN and the UE	11
5.1.1.3 Interaction to External Networks	11
5.1.2 Allocation of QoS management functions	12
5.1.2.1 QoS management functions for end-to-end IP QoS	12
5.2 Capabilities of Functional Elements.....	12
5.2.1 GGSN	13
5.2.2 UE.....	14
5.2.3 P-CSCF(PCF)	14
5.3 Go interface (PCF – GGSN).....	15
5.3.1 Go Functional Requirements	15
5.3.2 Information Elements Exchanged via Go Interface	15
5.4 QoS Parameters	17
5.5 QoS Parameter Mapping	17
6 End-to-End QoS Procedures.....	17
6.1 QoS Procedures in Functional Elements	17
6.1.1 Procedures in the GGSN.....	17
6.1.2 Procedures in the UE	17
6.1.3 Procedures in the P-CSCF(PCF).....	18
6.2 IP Bearer Level / Application Level Binding Mechanism.....	18
6.3 Session Flow : QoS Interaction Procedures.....	19
6.3.1 Authorize QoS Resources	19
6.3.2 Resource Reservation Message Flows.....	20
6.3.2.1 Service-based Local Policy	20
6.3.2.2 Resource Reservation with End-to-End RSVP	21
6.3.2.3 Resource Reservation with End-to-End RSVP and Service-based Local Policy	24
6.3.2.4 Service-based Local Policy and RSVP Sender/Receiver Proxy	27
6.3.3 Approval of QoS Commit.....	30
Annex A (Informative): QoS Conceptual Models.....	31
A.1 Introduction	31
A.2 Scenarios	32
A.2.1 Scenario 1	33
A.2.2 Scenario 2	34
A.2.3 Scenario 3	35
A.2.4 Scenario 4	38
A.2.5 Scenario 5	39
A.2.6 Scenario 6	41
Annex B (Informative): Session Flow: QoS Interaction Procedures – Disabling media stream, Revoke Authorization for UMTS and IP resources, Indication of PDP context release	43
B.1 Disabling media stream	43

B.2 Revoke Authorization for UMTS and IP Resources.....44
B.3 Indication of PDP Context Release45
Annex C (Informative): Sample Mapping of SDP Descriptions Into QoS Authorization..... 46
Annex D (Informative): Change History 50

Foreword

This Technical Specification (TS) has been produced by the 3rd Generation Partnership Project (3GPP).

The present document identifies the Quality of Service (QoS) aspects for the 3GPP system.

The contents of the present document are subject to continuing work within the TSG and may change following formal TSG approval. Should the TSG modify the contents of the present document, it will be re-released by the TSG with an identifying change of release date and an increase in version number as follows:

Version x.y.z

where:

- x the first digit:
 - 1 presented to TSG for information;
 - 2 presented to TSG for approval;
 - 3 or greater indicates TSG approved document under change control.
- y the second digit is incremented for all changes of substance, i.e. technical enhancements, corrections, updates, etc.
- z the third digit is incremented when editorial only changes have been incorporated in the document.

1 Scope

The present document provides the framework for end-to-end Quality of Service involving GPRS and complements TS23.107 which describes the framework for Quality of Service within UMTS. The end-to-end QoS architecture is provided in Figure 1. The document describes the interaction between the TE/MT Local Bearer Service, the GPRS Bearer Service, and the External Bearer Service, and how these together provide Quality of Service for the End-to-End Service. The document also describes IP level mechanisms necessary in providing end-to-end Quality of Service involving GPRS networks, including possible interaction between the IP level and the GPRS level, as well as the application level and the IP level.

In contrast to the TS23.107, the present document is only applicable to GPRS packet switched access services, and includes aspects of interworking to the IM subsystem as well as PSTN and other networks. The document does not cover the circuit switched access services.

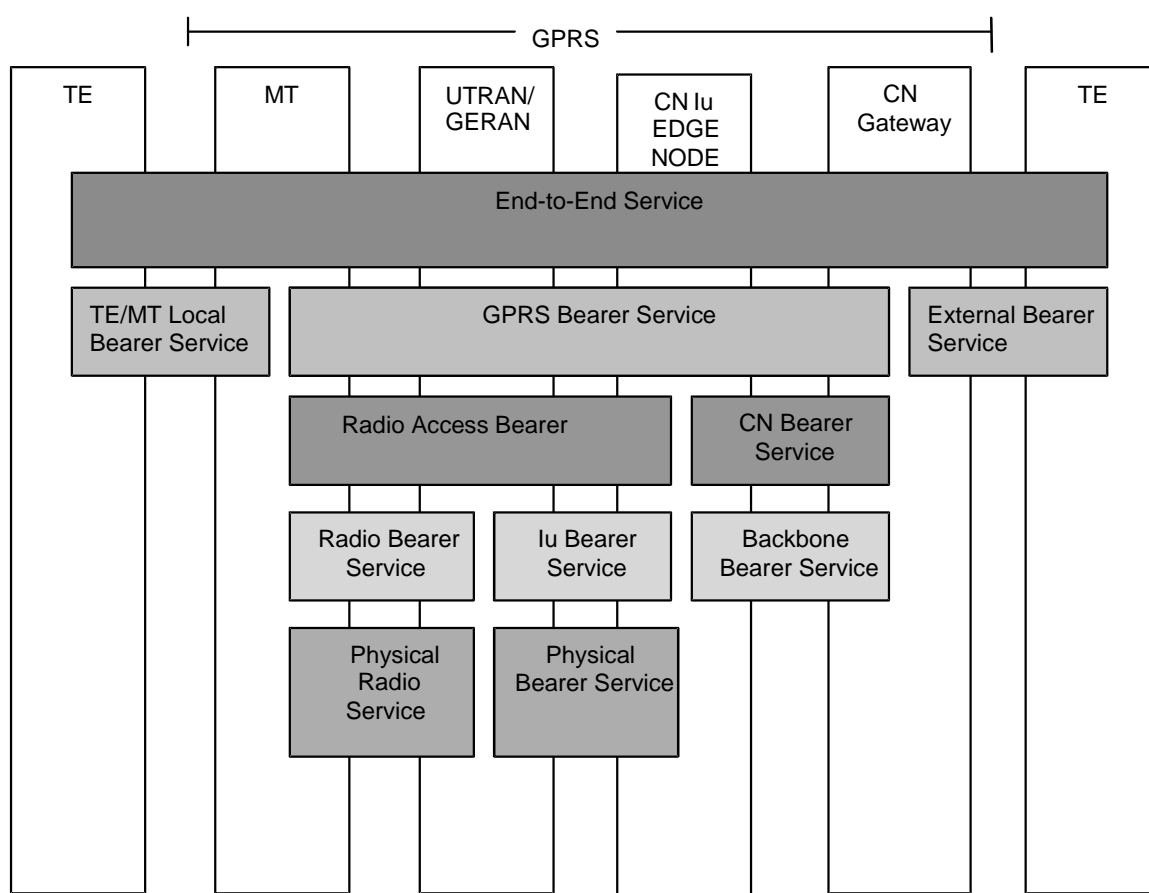

Figure 1: End-to-End QoS Architecture

2 References

The following documents contain provisions which, through reference in this text, constitute provisions of the present document.

- References are either specific (identified by date of publication, edition number, version number, etc.) or non-specific.

- For a specific reference, subsequent revisions do not apply.

- [1] 3GPP TS 22.288: “Service requirements for the IP Multimedia – stage 1”
- [2] 3GPP TS 23.002: “Network Architecture”
- [3] 3GPP TS 23.107: “QoS Concept and Architecture”
- [4] 3GPP TS 23.228: “IP Multimedia (IM) Subsystem – stage 2”
- [5] 3GPP TS 22.105: “Vocabulary for 3GPP Specifications”
- [6] RFC 2475: An Architecture for Differentiated Services (Diffserv)
- [7] RFC 2753: A Framework for Policy-based Admission Control
- [8] RFC 2748: Common Open Policy Service protocol (COPS)
- [9] RFC 2205: Resource ReSerVation Protocol (RSVP)
- [10] RFC 2209: Resource ReSerVation Protocol (RSVP) Message Processing Rules
- [11] RFC 2210: The use of RSVP with IETF integrated Services
- [12] RFC 1633: Integrated Services in the Internet Architecture: an Overview
- [13] RFC 2543: Session Initiation Protocol
- [14] RFC 2327: Session Description Protocol
- [15] RFC 2998: A Framework For Integrated Services Operation Over DiffServ Networks
- [16] RFC 2750: RSVP Extensions for Policy Control
- [17] RFC 2474: Definition of the Differentiated Services Field (DS Field) in the IPv4 and IPv6 Headers

3 Definitions and Abbreviations

3.1 Definitions

RSVP - Resource ReSerVation Protocol: The RSVP protocol [9] is used by a host to request specific qualities of service from the network for particular application data streams or flows. The network responds by explicitly admitting or rejecting RSVP requests.

DiffServ: Diffserv networks classify packets into one of a small number of aggregated flows or "classes", based on the Diffserv codepoint (DSCP) in the packet's IP header. This is known as behavior aggregate (BA) classification [6]. At each Diffserv router, packets are subjected to a "per-hop behavior" (PHB), which is invoked by the DSCP [17].

IntServ - The integrated services architecture [12] defined a set of extensions to the traditional best effort model of the Internet with the goal of allowing end-to-end QoS to be provided to applications. One of the key components of the architecture is a set of service definitions; the current set of services consists of the controlled load and guaranteed services. The architecture assumes that some explicit setup mechanism is used to convey information to routers so that they can provide requested services to flows that require them. While RSVP is the most widely known example of such a setup mechanism, the Intserv architecture is designed to accommodate other mechanisms.

COPS - Common Open Policy Service: The COPS protocol [8] is a simple query and response protocol that can be used to exchange policy information between a policy server (Policy Decision Point or PDP) and its clients (Policy Enforcement Points or PEPs).

3.2 Abbreviations

For the purpose of the present document, the following abbreviations apply:

APN	Access Point Name (*)
COPS	Common Open Policy Service protocol
DiffServ	Differentiated Services
DSCP	Diffserv Code Point
GERAN	GSM/EDGE Radio Access Network (*)
GGSN	Gateway GPRS Support Node (*)
HTTP	Hypertext Transfer Protocol (*)
IMS	IP Multimedia Subsystem
IntServ	Integrated Services
LAN	Local Area Network (**)
LDP	Label Distribution Protocol
MPLS	Multiprotocol Label Switching Architecture
PCF	Policy Control Function
PEP	Policy Enforcement Point
PHB	Per Hop Behavior
RNC	Radio Network Controller (*)
SDP	Session Description Protocol
SIP	Session Initiation Protocol (*)
SNMP	Simple Network Management Protocol (*)
TFT	Traffic Flow Template (*)

* this abbreviation is covered in 21.905v 4.2.0

** this abbreviation is covered in TR 101748 (GSM 01.04)

4 High Level Requirements for End-to-End IP QoS

4.1 End-to-End QoS Negotiation Requirements

- The UMTS QoS negotiation mechanisms used for providing end-to-end QoS shall be backward compatible with UMTS Release 99.
- The UMTS QoS negotiation mechanisms used for providing end-to-end QoS shall not make any assumptions about the situation in external networks which are not within the scope of 3GPP specifications.

- The UMTS QoS negotiation mechanisms used for providing end-to-end QoS shall not make any assumptions about application layer signalling protocols.
- No changes to non-UMTS specific QoS negotiation mechanisms.
- The UMTS QoS negotiation mechanisms used for providing end-to-end QoS shall not make any assumptions about applications which may be used on terminal equipment attached to mobile terminals.
- Unnecessary signalling complexity and processing complexity in the network elements as well as the mobile terminal shall be avoided.
- Unnecessary signalling traffic due to end-to-end QoS negotiation shall be avoided.
- Methods for user authentication as well as billing and charging mechanisms related to the end-to-end QoS negotiation shall be kept as simple as possible.
- Minimum changes to network architecture and mechanisms due to introduction of end-to-end QoS negotiation.
- The UMTS network shall be able to negotiate end-to-end QoS also for mobile terminals and applications which are not able to use QoS negotiation mechanisms other than the ones provided by UMTS.
- It shall be possible for an application on the external device to request end-to-end QoS.
- In order to enable the proper operation of service based local policy control, and to facilitate roaming in different networks, the mappings performed in various parts of the network need to be consistent.

4.2 QoS Policy Requirements

- The UMTS policy mechanisms described in TS 23.060 shall be used for control of the UMTS bearers.
- Interaction between UMTS bearer services and IP bearer services shall only occur at the translation function in the UE and GGSN.

5 End-to-End QoS Architecture

5.1 QoS Management Functions in the Network

To provide IP QoS end-to-end, it is necessary to manage the QoS within each domain. An IP BS Manager is used to control the external IP bearer service. Due to the different techniques used within the IP network, this communicates to the UMTS BS manager through the Translation function.

To enable coordination between events in the application layer and resource management in the IP bearer layer, a logical element, the Policy Control Function (PCF), is used as a logical policy decision element. It is also possible to implement a policy decision element internal to the IP BS Manager in the GGSN. The IP policy architecture does not mandate the policy decision point to be external to the GGSN.

Whenever resources not owned or controlled by the UMTS network are required to provide QoS, it is necessary to interwork with the external network that controls those resources. Interworking may be realised in a number of ways, including:

- signalling along the flow path (e.g. RSVP, LDP).
- packet marking or labelling along the flow path (e.g. DiffServ, MPLS)
- interaction between Policy Control and/or Resource Management elements.
- Service Level Agreements enforced by the border routers between networks.

For the policy control the following should apply:

- The IP policy framework employed in UMTS should, as far as possible, conform to IETF “Internet Standards”. The IETF policy framework may be used for policy decision, authorization, and control of the IP level functionality, at both user and network level.
- There should be separation between the scope and roles of the UMTS policy mechanisms and the IP policy framework. This is to facilitate separate evolution of these functions.

5.1.1 Description of functions

5.1.1.1 QoS management functions for end-to-end IP QoS in UMTS Network

NOTE: The end-to-end QoS management functions do not cover the cases of a circuit switched service, or an IP service interworking with an ATM service at the gateway node.

IP BS Manager uses standard IP mechanisms to manage the IP bearer services. These mechanisms may be different from mechanisms used within the UMTS, and may have different parameters controlling the service. When implemented, the IP BS Manager may include the support of DiffServ Edge Function and the RSVP function. The translation/mapping function provides the inter-working between the mechanisms and parameters used within the UMTS bearer service and those used within the IP bearer service, and interacts with the IP BS Manager. In the GGSN, the UMTS QoS parameters are mapped into IP QoS parameters, where needed. In the UE, the QoS requirements determined from the application layer (e.g., SDP) are mapped to either the PDP context parameters or IP layer parameters (e.g., RSVP).

If an IP BS Manager exists both in the UE and the Gateway node, it is possible that these IP BS Managers communicate directly with each other by using relevant signalling protocols.

The required options in the table define the minimum functionality that shall be supported by the equipment in order to allow multiple network operators to provide interworking between their networks for end-to-end QoS. Use of the optional functions listed below, other mechanisms which are not listed (e.g. over-provisioning), or combinations of these mechanisms are not precluded from use between operators.

The IP BS Managers in the UE and GGSN provide the set of capabilities for the IP bearer level as shown in Table 1. Provision of the IP BS Manager is optional in the UE, and required in the GGSN.

Table 1: IP BS Manager capability in the UE and GGSN

Capability	UE	GGSN
DiffServ Edge Function	Optional	Required
RSVP/IntServ	Optional	Optional
IP Policy Enforcement Point	Optional	Required (*)

(*)Although the capability of IP policy enforcement is required within the GGSN, the control of IP policy through the GGSN is a network operator choice.

Figure 2 shows the scenario for control of an IP service using IP BS Managers in both possible locations in the UE and Gateway node. The figure also indicates the optional communication path between the IP BS Managers in the UE and the Gateway node.

Policy Control Function (PCF) is a logical policy decision element which uses standard IP mechanisms to implement policy in the IP bearer layer. These mechanisms may be conformant to, for example, the framework defined in IETF [RFC2753] “A Framework for Policy-based Admission Control” where the PCF is effectively a Policy Decision Point (PDP). The PCF makes decisions in regard to network based IP policy using policy rules, and communicates these decisions to the IP BS Manager in the GGSN, which is the IP Policy Enforcement Point (PEP).

The Policy Control Function (PCF) is a logical entity of the P-CSCF. If the PCF is implemented in a separate physical node, the interface between the PCF and P-CSCF is not standardized.

The interface between the PCF and GGSN is specified within 3GPP, named Go interface, and is included in the Reference Architecture depicted in TS23.002. The protocol interface between the PCF and GGSN supports the transfer of information and policy decisions between the policy decision point and the IP BS Manager in the GGSN.

The PCF makes policy decisions based on information obtained from the P-CSCF. In the P-CSCF(PCF), the application level parameters (e.g., SDP) are mapped into IP QoS parameters. The P-CSCF (PCF) is in the same domain as the GGSN or has a trust relationship with the GGSN.

NOTE: Currently in IETF, inter-domain policy interactions are not defined.

5.1.1.2 IP BS Manager Functionality in the GGSN and the UE

The following capabilities of the IP BS manager support applications that require stringent IP quality of service (e.g., carrier-grade telephony),

1. Existing QoS management mechanisms in 23.107 with any required extensions, e.g., binding mechanism.
2. The IP BS manager in the GGSN acting as an RSVP endpoint towards the external network, generating and responding to per-flow RSVP messages.

Use of RSVP is intended to enable the external network provider to support traffic engineering, efficient resource management, and call blocking if needed to handle temporary overload conditions.

It is also desired to allow endpoints to use Diffserv or RSVP to indicate their QoS requirements to the MT. The requirements on the IP bearer service manager in the UE and GGSN to support this functionality are FFS.

At PDP context setup the user shall have access to one of the following alternatives :

- Basic GPRS IP connectivity service: The bearer is established according to the user's subscription, local operator's IP bearer resource based policy, local operator's admission control function and GPRS roaming agreements. In this case, IP bearer resource based local policy decisions may be applied to the bearer.
- Enhanced GPRS based services : The bearer is used to support an enhanced application-layer service, such as IM. In this case, service-based local policy decisions (e.g., authorization and gating of the bearer by a proxy CSCF) may be applied to the bearer.

5.1.1.3 Interaction to External Networks

Within the UMTS network, there is resource management performed by various nodes in the admission control decision. The resources considered here are under the direct control of the UMTS network.

In IP Networks, it is also necessary to perform resource management to ensure that resources required for a service are available. Where the resources for the IP Bearer Service to be managed are not owned by the UMTS network, the resource management of those resources would be performed through an interaction between the UMTS network and that external network.

In addition, where the UMTS network is also using external IP network resources as part of the UMTS bearer service (for example for the backbone bearer service), it may also be necessary to interwork with that network.

The GGSN shall support DiffServ edge functionality and be able to shape upstream traffic. There are a number of other mechanisms provided to support interoperator interworking, some of which are given below.

Note: This list is not exhaustive. Other options are possible.

- Signalling along the flow path: In this scenario, resource requirements are explicitly requested and either granted or rejected through the exchange of signalling messages between network elements along the path of the IP packet flow. Signalling may be performed on a per-flow basis (e.g. using end to end RSVP) or it may be performed for an aggregate set of flows. In the latter case, it is expected that signalling exchanges would only be required when there are changes required in the resources allocated to an aggregate set of flows.

- Interaction between network management entities: In this scenario, resource requirements need to be explicitly negotiated and provisioned through network management entities. The results of this exchange are then enforced in the border nodes separating DiffServ administrative domains.
- Service Level Agreements enforced by the border routers between networks: In this scenario, resources are allocated along the path based on agreements between the network operators. The border routers along the path flow are provisioned with the characteristics of the aggregated traffic that is allowed to flow between systems.

5.1.2 Allocation of QoS management functions

5.1.2.1 QoS management functions for end-to-end IP QoS

The QoS management functions for controlling the external IP bearer services and how they relate to the UMTS bearer service QoS management functions are shown in Figure 2.

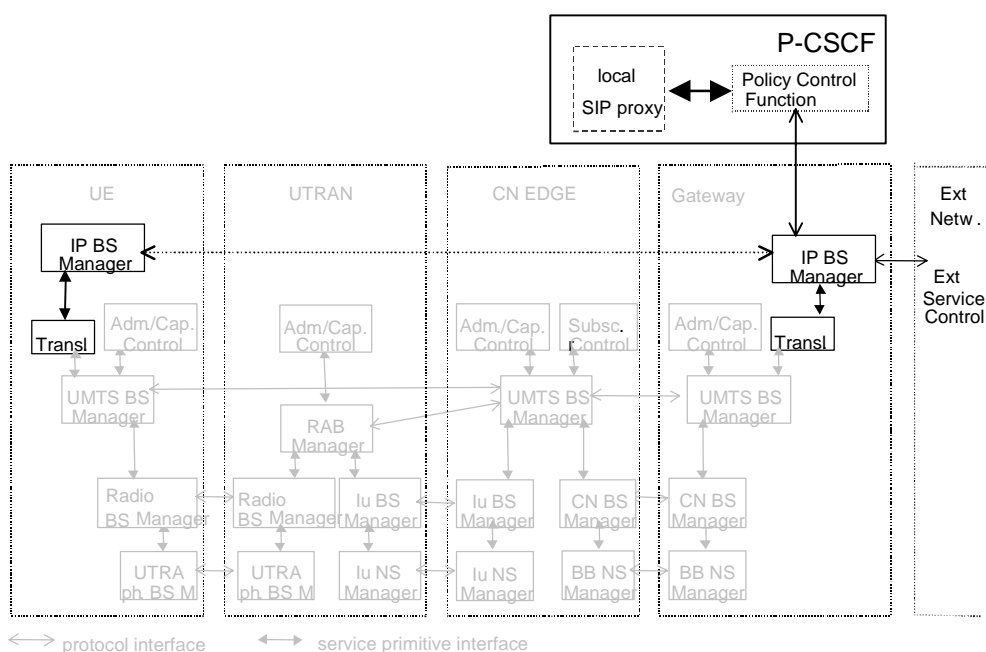

Figure 2: QoS management functions for UMTS bearer service in the control plane and QoS management functions for end-to-end IP QoS

NOTE: The dimmed boxes in Figure 2 are clarified in TS23.107.

NOTE: The following will be revisited in the Release 6 timeframe: - the possible reuse of the protocols in the Gs interface between the GGSN and other application servers, and possible interfaces between the PCF and the P-CSCF, and between the PCF and other application servers.

[Editorial note: Figure 2 and this chapter shows UE only as a combined element. This TS also need to consider the case where the TE and MT are split. A section providing the split and the distribution of functionality need to be added to this TS and is for further study. Standardization of the interface between the TE and MT is the responsibility of the 3GPP working group TSG T2, and is outside the scope of this TS.]

5.2 Capabilities of Functional Elements

This section provides functional descriptions of capabilities in GGSN, UE, and P-CSCF(PCF).

5.2.1 GGSN

This clause provides functional descriptions of capabilities in GGSN. The capabilities are part of IP BS Manager (see 5.1.1.1) or corresponding user plane functions. Determination of exactly which functions are required to support interoperator and multi-vendor aspects are not addressed in this clause.

The **DiffServ Edge Function** shall be compliant to the IETF specifications for Differentiated Services. The IETF Differentiated Services architecture will be used to provide QoS for the external bearer service.

RSVP/IntServ Function

[Editors note: Detailed functional description of RSVP/IntServ Function is FFS]

The **RSVP Sender/Receiver Proxy** uses information derived from the Go interface and acts as an RSVP endpoint towards the external network, generating and responding to per-flow RSVP messages on behalf of the UE. In the uplink direction, the RSVP Sender Proxy originates the Path message on behalf of the UE. It must also periodically refresh the Path message and correctly terminate the Resv, ResvTear and PathErr messages for the session. In the downlink direction, the RSVP Receiver Proxy terminates the Path message and generates the Resv message on behalf of the UE. A Resv Proxy state is installed which act as if the proxy has received a Resv from the true endpoint UE. This involves reserving resource, if required, sending periodic refreshes of the Resv message and tearing down the reservation if the Path is torn down.

[Editors note: Detailed functional description of how GGSN identify that RSVP SenderReceiver Proxy shall be activated is FFS]

The **Service-based Local Policy Enforcement Point** controls the quality of service that is provided to a set of IP packets (or IP “flow”) defined by a packet classifier. The policy enforcement function includes policy-based admission control that is applied to the IP bearers associated with the flow, and configuration of the packet handling and “gating” functionality in the user plane. Service-based local policy decisions are either “pushed” to or requested by the GGSN via the Go interface.

Policy-based admission control ensures that the resources that can be used by a particular IP flow are within the “authorized resources” specified via the Go interface. The authorized resources provide an upper bound on the resources that can be reserved or allocated for an IP flow. The authorized resources may be expressed as an Intserv-style Flowspec. This information is mapped by the translation/mapping function in the GGSN to give the authorized resources for UMTS bearer admission control.

In the user plane, policy enforcement is defined in terms of a “gate” implemented in the GGSN. A gate is a policy enforcement function that interacts through Go interface with PCF as the Policy Decision Point for QoS resource authorisation at the IP BS level for a unidirectional flow of packets. “Open”/“Close” gate operations as defined in TS23.228 are to enable/disable media flows and are under the control of P-CSCF (PCF). A gate operates on a unidirectional flow of packets, i.e., in either the upstream or downstream direction. A gate consists of a packet classifier, a traffic metering function, and user plane actions to be taken for the set of packets matching the classifier. When a gate is enabled, the packets in a flow are subject to the Diffserv edge treatment (policing or marking) as determined by traffic metering and user plane actions. When a gate is disabled, all of the packets in the flow are dropped.

The packet classifier associated with a gate is a micro-flow classifier including the standard 5-tuple: (source IP address, destination IP address, source port, destination port, protocol), identifying a set of packets associated with a unidirectional flow¹.

Elements of the 5-tuple may be wild-carded. This is FFS in Stage 3 work. It is possible for a set of packets to match more than one classifier. When this happens, the sequence of actions associated with the gates are executed in sequence. Packets that are marked by a gate may not be (re)marked by a subsequent gate to a Diffserv Code Point corresponding to a better service class.

The **Binding Mechanism Handling** associates the PDP context bearer with one or more IP flows in order to support service-based local policy enforcement and QoS inter-working. Binding information is included in PDP Context Activation or Modification messages to associate the PDP context bearer with QoS and policy decision information provided by the PCF and associated with IP flows. The PDP Configuration Options parameter shall be used to carry the binding information. The PDP Configuration Options parameter is one of the optional parameters signaled in PDP

¹ This packet classifier should not be confused with the Traffic Flow Template (TFT), which serves a different purpose from the gate.

Context Activation/Modification messages. In order to allow QoS and policy information to be "pulled" from the PCF, the binding information shall allow the GGSN to determine the address of the PCF to be used.

5.2.2 UE

This clause provides functional descriptions of capabilities in UE. The capabilities are part of IP BS Manager (see 5.1.1.1) or corresponding user plane functions. Determination of exactly which functions are required to support interoperator and multi-vendor aspects are not addressed in this clause.

DiffServ Edge Function acts as a DiffServ (DS) boundary for the traffic from applications running on the UE. As specified in RFC2475, DS boundary node must be able to apply the appropriate PHB to packets based on the DS code point. In addition, DS boundary nodes may be required to perform traffic conditioning functions. When GGSN DiffServ marking is used, the DiffServ edge function in the UE is not needed.

RSVP/Intserv Function provides the capability for the UE to request end-to-end QoS using RSVP messages as defined in IETF standards. RSVP messages may also be used by the network to inform the DSCP to be used by the UE. RSVP messages shall include the authorization token and flow identifier(s) in a policy data object if the authorization token is available in the UE. RSVP may be used to trigger PDP context activation/modification. The inter-working between MT and TE is FFS.

Binding Mechanism associates the PDP context bearer to the IP flow to support IP policy enforcement and QoS inter-working in the GGSN (e.g., RSVP Send/Receiver Proxy). The authorization token and flow identifiers are used to provide the binding mechanism and is included by the UE in the PDP Context Activation or Modification messages. The PDP Configuration Options parameter shall be used for this purpose. The PDP Configuration Options parameter is one of the optional parameters signaled in PDP Context Activation/Modification. The authorization token may also be used to bind a RSVP session with a SIP session by including the authorization token and flow identifier(s) in RSVP messages. For IMS services, the authorization token is provided to the UE by the P-CSCF during SIP session establishment.

The **Pre-conditions for SIP QoS Assured Sessions** shall be according to the principles for when a UE shall regard the SIP QoS preconditions to be met, as stated in TS23.228. The functionality shall be compliant to the IETF specification on Integration of Resource Management and SIP.

5.2.3 P-CSCF(PCF)

This clause provides functional descriptions of capabilities in P-CSCF(PCF). Determination of exactly which functions are required to support interoperator and multi-vendor aspects are not addressed in this clause.

Service-based Local Policy Decision Point

- Authorize QoS resources (bandwidth, etc.) for the session. The P-CSCF (PCF) shall use the SDP contained in the SIP signaling message to calculate the proper authorization. The authorization shall be expressed in terms of the IP resources to be authorized. The authorization shall include limits on IP packet flows and restrictions on IP destination address and port.
- The P-CSCF (PCF) shall be able to decide if new QoS authorization (bandwidth, etc.) is needed due to the mid-call media or codec change. A new authorization shall be required when the resources requested by the UE for a flow exceeds previous authorization, or a new flow is added, or when elements of the packet classifier(s) for authorized flows change.
- The PCF functions as a Policy Decision Point for the service-based local policy control.
- The PCF shall exchange the authorization information with the GGSN via the Go interface.
- The P-CSCF (PCF) provides final decisions on enabling and disabling the allocated QoS resources for the authorized media stream. The decision shall be transferred from the PCF to the GGSN.
- At IP multimedia session release, the P-CSCF (PCF) shall revoke the resources authorization for the session. In cases when the UE cannot perform this release itself (i.e., loss of signal from the mobile), the P-CSCF (PCF) shall provide indication to the GGSN that the previously authorized resource has been revoked.

Binding Mechanism Handling

- The P-CSCF(PCF) generates an authorization token for each SIP session and send the authorization token to the UE in the SIP message. The authorization token contains information that identifies the P-CSCF(PCF) . The

authorization token shall be unique across all PDP contexts associated with an APN. The authorization token conforms to the IETF specification on SIP Extensions for Media Authorization.

- The P-CSCF(PCF) shall generate a new authorization token when a new authorization is required.

5.3 Go interface (PCF – GGSN)

5.3.1 Go Functional Requirements

The Go interface allows service-based local policy and QoS inter-working information to be “pushed” to or requested by the GGSN from a Policy Control Function (PCF). The Go interface provides information to support the following functions in the GGSN:

- Control of Diffserv inter-working
- Control of RSVP admission control and inter-working
- Control of “gating” function in GGSN
- UMTS bearer authorization
- QoS charging related function

The Common Open Policy Service (COPS) protocol supports a client/server interface between the Policy Enforcement Point in the GGSN and Policy Control Function (PCF). The Go interface shall conform to the IETF COPS framework as a requirement and guideline for Stage 3 work.

The COPS protocol allows both push and pull operations. For the purpose of the initial authorisation of QoS resources the pull operation shall be used. Subsequently the interactions between the PCF and the GGSN may use either pull or push operations.

Policy decisions may be stored by the COPS client in a local policy decision point allowing the GGSN to make admission control decisions without requiring additional interaction with the PCF.

5.3.2 Information Elements Exchanged via Go Interface

The COPS protocol supports several messages between a client and server. These messages consist of the following operations that may be performed:

- Client-Open/Client-Accept/Client-Close
- Request
- Decision
- Report State
- Delete Request State
- Keep Alive
- Synchronize State Request/Synchronize State Complete

Additional UMTS-specific information elements must be included in COPS messages to support the policy and QoS inter-working functions identified in Section 5.3.1. Consistent with the COPS framework, the Go interface is identified by a “client type” allocated for a UMTS COPS client (GGSN).

All of the information described in the remainder of this section applies specifically to the GGSN COPS client type. The events specific to the UMTS or IP bearer service would trigger the request messages from the UMTS PEP to the PCF. The information elements specific to UMTS would be standardized and carried in the UMTS specific interactions between the PCF and the GGSN.

A **Request** message from the GGSN to the PCF shall allow the GGSN to request policy and QoS inter-working information for an IP flow identified by binding information (described below).

A **Decision** message from the PCF to the GGSN shall include the following *commands* :

- NULL Decision (No configuration data available)
- Install (Admit request/Install configuration, Commit)
- Remove (Remove request/Remove configuration)

These commands are used to:

- Authorize QoS/Revoke QoS authorization for one or more IP flows
- Enable/Disable forwarding for one or more IP flows

The **responses** from the PEP to the PCF include an acknowledgement and/or an error response to commands:

- Report State (Success/Failure/Accounting)

The **Authorize QoS command** contains the following policy and QoS inter-working information associated with an IP flow:

- UMTS specific Binding information (e.g. Token)
- Packet classifier (e.g. RSVP filterspec)
- Authorized flowspec
- Packet handling action
- DSCP
- Event generation information

Binding information associates the policy and QoS inter-working information in the message with a PDP context. The binding information includes 1) an authorization token sent by the P-CSCF to the UE during SIP signaling. , and may include 2) one flow identifier used by the UE, GGSN and PCF to uniquely identify an IP media flow.

The authorization token shall be unique locally. The authorization token conforms to the IETF specification on SIP Extensions for Media Authorization.

A flow identifier identifies an IP media flow associated with the SIP session. Flow identifiers are based on the ordering of media flows in the SDP. A flow identifier combined with the authorization token shall be sufficient to uniquely identify an IP media flow.

The packet classifier includes the standard 5-tuple: (source IP address, destination IP address, source port, destination port, protocol), identifying a set of packets associated with a unidirectional flow. Elements of the 5-tuple may be wild-carded.

The authorized flowspec provides an upper bound on the resources that can be reserved or allocated for an IP flow. The authorized flowspec is expressed as an Intserv-style flowspec .

The packet handling action defines the packet handling that should be accorded to in-profile and out-of-profile packets matching the packet classifier. In-profile traffic is defined to be traffic that is within the authorized flowspec.

The DSCP from the PCF shall determine the highest QoS class that can be applied to this IP flow.

Event generation information contains opaque information that the GGSN includes in usage records (e.g. CDR) associated with the authorized UMTS bearers. The event generation information includes information identifying the authorized IP flow. It also includes information used to correlate usage records from the GGSN with SIP session records from the P-CSCF.

The **Revoke QoS Authorization**, **Enable Forwarding** and **Disable Forwarding** commands provide only the information that is needed to perform the action (e.g., the COPS handle element, which is used as a way of identifying the installed decision information).

5.4 QoS Parameters

[Editors note: Details for this section are for further study]

5.5 QoS Parameter Mapping

[Editors note: Details for this section are for further study]

6 End-to-End QoS Procedures

6.1 QoS Procedures in Functional Elements

This section describes the main procedures that are used for the end-to-end QoS management. These procedures are described in text description for each involved network elements. The procedures described in this document are meant to provide a high level description for further Stage 3 work and are not intended to be exhaustive.

6.1.1 Procedures in the GGSN

The QoS procedures in the GGSN are triggered by the QoS signaling messages from the UE, i.e., PDP Context Activation message or the RSVP messages. The exact QoS procedures in the GGSN depend on the GGSN and UE QoS capabilities. The GGSN is required to support DiffServ edge function. Other QoS capabilities that may be supported at the GGSN are RSVP functions, RSVP Proxy functions and service-based local policy enforcement functions.

For UEs that do not support RSVP, the GGSN may use the IP level information (e.g., addressing 5-tuple) provided by service based local policy according to the authorization token to configure the DiffServ classifier functionality and provide internetworking between PDP context and backbone IP network. The authorization token is included in the PDP context activation/modification messages. The GGSN may also invoke RSVP Proxy function for the UE. The decision mechanism on whether or not to do RSVP Proxy for a session is FFS.

For UEs that support RSVP, the GGSN may also support RSVP and use RSVP rather than the PDP context to control the QoS through the backbone IP network. The GGSN may use IP level information provided by service based local policy according to authorization token to authorize the RSVP session and configure the DiffServ classifier functionality. The authorization token is included in the RSVP signaling and the PDP context activation/modification messages. Alternatively, the RSVP messages may pass transparently through the GGSN.

If service based local policy is implemented in the operator's network, the GGSN shall authorize the PDP context activation/modification messages and RSVP messages by sending the request to the PCF or from the cached policy in the Local Decision Point.

6.1.2 Procedures in the UE

The QoS procedures in the UE are triggered by the application layer (e.g., SIP/SDP) QoS requirements. The exact QoS procedures in the UE depend on the UE QoS capabilities.

For UEs that support only UMTS QoS mechanism, the application QoS requirements will trigger a PDP Context Activation procedure with the corresponding UMTS QoS parameters. If the UE received the Authorization Token in the SIP messages, the UE shall include the Authorization Token in the PDP Context Activation message if the PDP Context is associated to the session.

For UEs that support both IP (e.g., IP BS Manager) and UMTS QoS mechanism, the application QoS requirements are mapped down to the IP layer QoS parameters. The IP layer parameters are further mapped down to the PDP context parameters in the UE. If the UE received the Authorization Token in the SIP messages, the UE shall include the Authorization Token in the PDP Context Activation message if the PDP context is associated to the session.

For UEs that support RSVP, the application QoS requirements are mapped down to create an RSVP session. The UE shall establish a PDP context suitable for support of the RSVP session. If the UE received the Authorization Token in the SIP messages, the UE shall include the Authorization Token in both the PDP Context Activation message and RSVP messages if the PDP Context/RSVP is associated to the session.

For UEs that does not support RSVP, the GGSN may function as RSVP Proxy on the UE's behalf. The mechanism is FFS.

At the session release, the UE shall release all QoS resources allocated for the session.

6.1.3 Procedures in the P-CSCF(PCF)

The QoS procedures in P-CSCF(PCF) are related to service based local policy control.

The QoS resource authorization procedure is triggered by the P-CSCF receiving a SIP message with SDP. The SDP contains sufficient information about the session, such as the end-points, bandwidth requirements and the characteristics of the media exchange. The P-CSCF initiates a policy setup in PCF for the session. The PCF shall authorize the required QoS resources and install the IP bearer level policy for the session.

The Authorization-Token is generated by the P-CSCF(PCF) and sent to the UE. For the originating UE, the Authorization-Token shall be included in the SIP message (183) from P-CSCF to the UE. For the terminating UE, the Authorization-Token shall be included in the SIP Invite message from P-CSCF to the UE.

Upon receiving the bearer authorization request from the GGSN, the PCF shall authorize the request according to the stored service based local policy for the session.

Upon receiving the SIP 200 OK message, the P-CSCF provides final decision to enable the allocated QoS resource for the authorized media stream.

During the mid-call SIP signaling for media or codec change, the P-CSCF shall be able to decide if new QoS authorization is needed. A new authorization shall be required when the resources requested by the UE for a flow exceeds previous authorization, or a new flow is added, or when elements of the packet classifier(s) for authorized flow changed.

At session release, the P-CSCF shall disable the media stream and revoke the resource authorization for the session in the PCF.

6.2 IP Bearer Level / Application Level Binding Mechanism

The *binding mechanism* associates the PDP context bearer with policy information in the GGSN to support service based local policy enforcement and QoS inter-working. The policy and QoS decision information in the GGSN is based on IP media flows. The binding mechanism identifies the IP media flow(s) associated with a PDP context bearer and uses this information in selecting the policy information to apply.

The UE shall be able to include binding information in PDP Context Activation or Modification messages to associate the PDP context bearer with policy information. The PDP Configuration Options parameter shall be used for this purpose. The PDP Configuration Options parameter is one of the optional parameters signalled in PDP Context Activation/Modification. The binding information includes 1) an Authorization Token sent by the P-CSCF(PCF) to the UE during SIP signaling, and 2) one or more Flow Identifiers which are used by the UE, GGSN and PCF to uniquely identify the IP media flow(s). If the session has only one IP flow, then the Flow Identifier may not be needed.

The authorization token shall be unique locally. The Authorization Token conforms to the IETF specification on SIP Extensions for Media Authorization.

A Flow Identifier identifies an IP media flow associated with the SIP session. Flow Identifiers are based on the sequence of media flows in the SDP. A Flow Identifier combined with the Authorization Token shall be sufficient to uniquely identify an IP media flow.

In order to allow QoS and policy information to be "pulled" from the PCF, the authorization token shall allow the GGSN to determine the address of the PCF to be used.

When the SDP changes during a SIP session, the P-CSCF(PCF) shall generate a new authorization token to be used by the UE in subsequent PDP context activation/modification requests.

6.3 Session Flow : QoS Interaction Procedures

This section highlights possible additions to the GPRS bearer establishment procedures specified in TS23.060 for support of IM Services, and describes the QoS interactions involved within the sub-procedure blocks for Authorize QoS Resources, Resource Reservation, and Approval of QoS Commit in Chapter 5: 'IP multimedia subsystem procedures' of TS23.228. The possible additions refer to procedures on the use of Service-based Local Policy, RSVP Signalling, and RSVP Sender/Receiver Proxy, as well as the allowed combinations.

It shall be possible according to operator choice to use solely the GPRS bearer establishment procedures specified in TS23.060 without the additions described in this section.

For cases where Service-based Local Policy is not used, the Authorize QoS Resources and the Approval of QoS Commit sub-procedure blocks are effectively non-existent in TS23.228.

For the flow sequences involving RSVP, the following are assumed:

- the successful setup of RSVP signalling.
- bi-directional PDP contexts are being set up.

For the flow sequences involving Authorize QoS Resources and Approval of QoS Commit, the following are assumed:

- the successful authorization of QoS resources.
- the successful approval of QoS commit.

Note: The exact functional split (e.g., which entity generates the authorization token) between the P-CSCF and PCF, and whether this shall be standardized in R5 is FFS.

Note: Whether 'gate' corresponds to a single IP flow or multiple IP flows is FFS.

Note: 'Activate (Secondary) PDP Context' here means that either Primary or Secondary PDP context may be activated.

Note: When necessary, it is assumed that there is an existing PDP context that carries signalling (e.g., RSVP) between the UE and GGSN.

6.3.1 Authorize QoS Resources

The Authorize QoS Resources procedure is triggered by the P-CSCF receiving a SDP message. The SDP message contains sufficient information about the session, such as the end-points, bandwidth requirements, and the characteristics of the media exchange.

The PCF shall authorize the required QoS resources for the session and install the IP bearer level policy based on information from the P-CSCF. In order to ensure that the IP bearer flow correlates to the one approved during the SIP session establishment, the SIP extensions for media authorization proposed in IETF shall be used.

The Authorization-Token is generated by the P-CSCF(PCF) and sent to the UE. For the originating UE, the Authorization-Token shall be included in the SIP message (183) from P-CSCF to the UE. For the terminating UE, the Authorization-Token shall be included in the SIP Invite message from P-CSCF to the UE.

The PCF makes decision and communicates these decisions to the IP BS Manager in the GGSN, which is the Policy Enforcement Point (PEP) for the IP bearer service. The interface between the PCF and PEP is the COPS protocol defined by IETF.

For the purpose of the initial authorization of QoS resources the pull operation shall be used. (Reference Section 5.3 Go interface for details.)

The following figure is applicable to both the Mobile Originating (MO) side and the Mobile Terminating (MT) side.

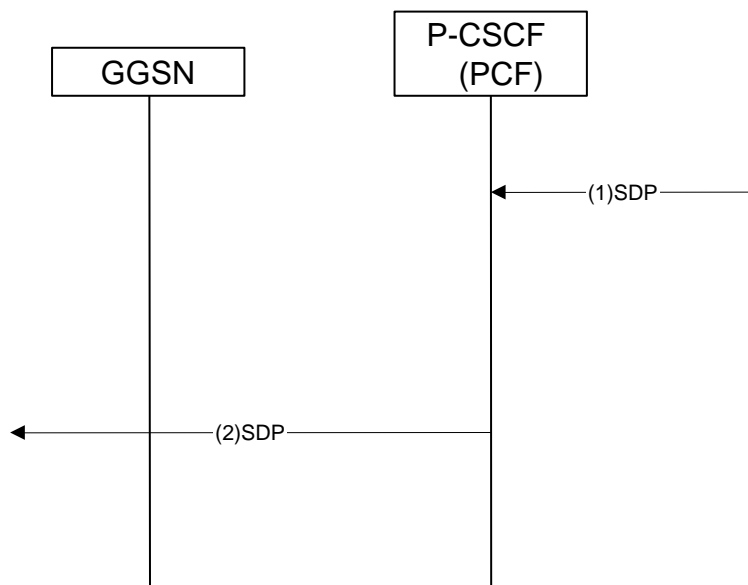

Figure 3: Authorize QoS Resources

1. The SIP “SDP” message is received by the P-CSCF. The PCF shall authorize the required QoS resources for the session and install the IP bearer level policy based on information from the P-CSCF.
2. Upon successful authorization of the session, the P-CSCF forwards the SDP message to the UE for the originating side. For the terminating side, the P-CSCF forwards the SDP message to the terminating S-CSCF.

6.3.2 Resource Reservation Message Flows

6.3.2.1 Service-based Local Policy

For this case, Service-based Local Policy is added to the GPRS bearer establishment procedures specified in TS23.060.

This section provides the flows for bearer establishment, resource reservation and policy control with PDP Context setup and DiffServ inter-working.

The following figure is applicable to both the Mobile Originating (MO) side and the Mobile Terminating (MT) side.

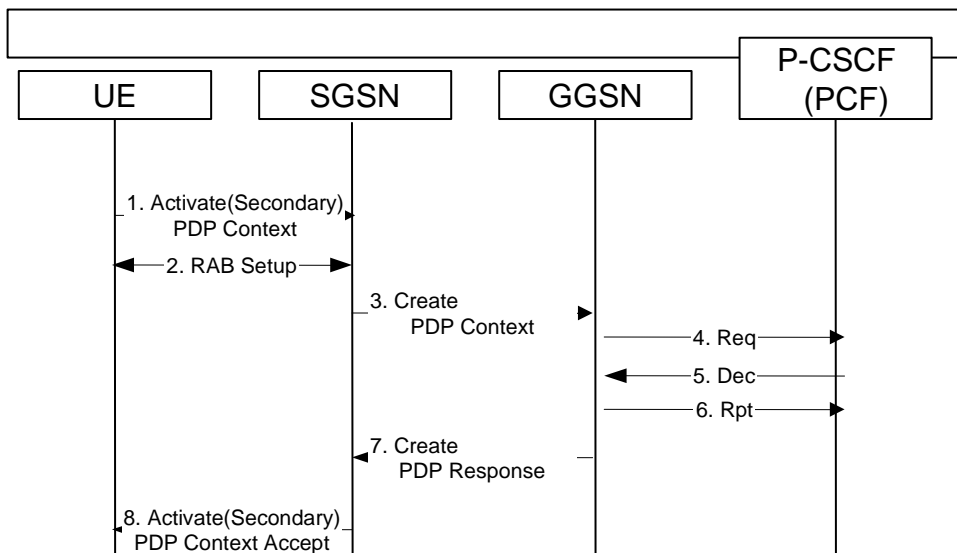

Figure 4: Service-based Local Policy

1. The UE sends an Activate (Secondary) PDP Context message to the SGSN with the UMTS QoS parameters. The UE includes the Binding Information in the Activate PDP Context message.
2. The radio access bearer (RAB) setup procedure is performed.
3. The SGSN sends the corresponding Create PDP Context message to the GGSN.
4. The GGSN sends a COPS REQ message with the Binding Information to the PCF in order to obtain relevant policy information.
5. The PCF sends a COPS DEC message back to the GGSN.
6. The GGSN sends a COPS RPT message back to the PCF.
7. The GGSN uses the policy information to accept the PDP activation request, and sends a Create PDP Context Response message back to SGSN.
8. The SGSN sends an Activate (Secondary) PDP Context Accept message to UE.

6.3.2.2 Resource Reservation with End-to-End RSVP

For this case, RSVP is added to the GPRS bearer establishment procedures specified in TS23.060, with no Service-based local policy.

Note: The diagrams in this subsection depict one possible signalling sequence, however, the alternative signalling sequences below are possible:

- to trigger the Create PDP Context Request message after the PATH message.
- to trigger the Create PDP Context Request message after the RESV message.
- to trigger only one PDP context after all RSVP exchanges have completed.

Note: The diagrams in this subsection depict the case when the GGSN is not RSVP aware, however, the alternative of GGSN being RSVP aware is also possible.

The following figure is applicable to the Mobile Originating (MO) side.

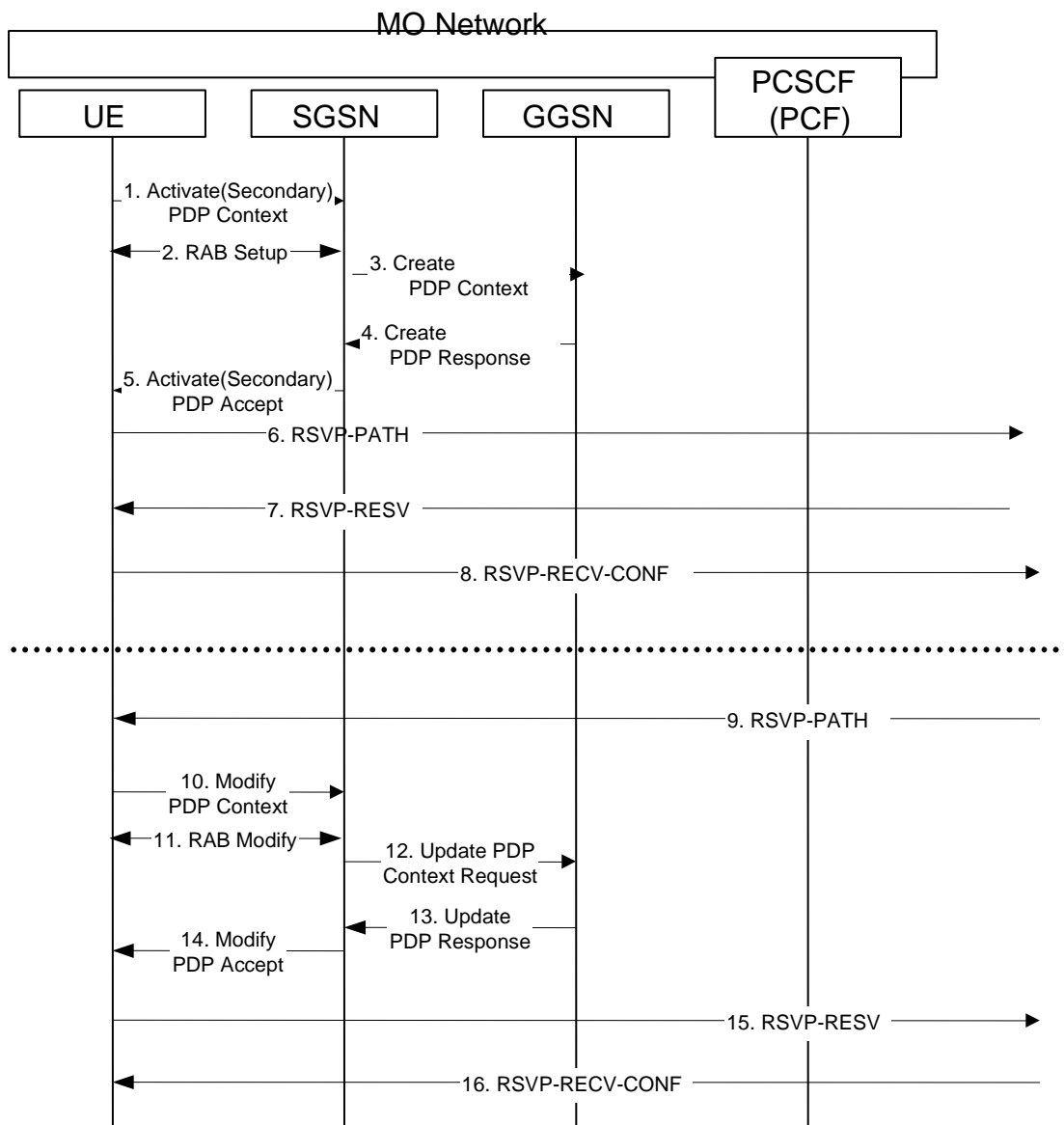

Figure 5: MO Resource Reservation with End-to-End RSVP

Note: There is no timing relationship between the set of flows for the uplink (above the line) and the downlink (below the line).

1. The UE sends an Activate (Secondary) PDP Context message to the SGSN with the UMTS QoS parameters.
2. The radio access bearer (RAB) setup procedure is performed.
3. The SGSN sends the corresponding Create PDP Context message to the GGSN.
4. The GGSN authorizes the PDP context activation request according to the local operator's IP bearer resource based policy, the local operator's admission control function and the GPRS roaming agreements and sends a Create PDP Context Response message back to the SGSN.
5. The SGSN sends an Activate (Secondary) PDP Context Accept message to UE.
6. UE sends an RSVP PATH message to the next hop, through the GGSN. The GGSN does not process the RSVP PATH message. Alternatively, the GGSN may process the RSVP PATH message and forward it to the next hop.

7. The UE receives the RSVP RESV message in the downlink direction, through the GGSN. The GGSN does not process the RSVP RESV message. Alternatively, the GGSN may process the RSVP RESV message and forward it to the UE.
8. The UE sends a RSVP RESV-CONF message to the next hop. The use of the RESV-CONF message is optional.
9. The UE receives a RSVP PATH message in the downlink direction, through the GGSN. The GGSN does not process the RSVP PATH message. Alternatively, the GGSN may process the incoming RSVP PATH message and forward it to the UE.
10. The UE may send a Modify PDP Context message to the SGSN with the necessary modification to UMTS QoS parameters according to the received RSVP PATH message.
11. The radio access bearer (RAB) modification procedure is performed.
12. The SGSN sends the corresponding Update PDP Context Request message to the GGSN.
13. The GGSN authorizes the PDP context modification according to the local operator's IP bearer resource based policy, the local operator's admission control function and the GPRS roaming agreements and sends an Update PDP Context Response message back to the SGSN.
14. The SGSN sends a Modify PDP Context Accept message to UE.
15. UE sends the RSVP RESV message to the next hop, through the GGSN. The GGSN does not process the RSVP RESV message. Alternatively, the GGSN may process the RSVP RESV message and forward it to the next hop.
16. The UE receives the RSVP RESV-CONF message in the downlink direction. The use of the RESV-CONF message is optional.

The following figure is applicable to the Mobile Terminating (MT) side. As the flow is the mirror of the Mobile Originating (MO) side, the step-by-step description is omitted.

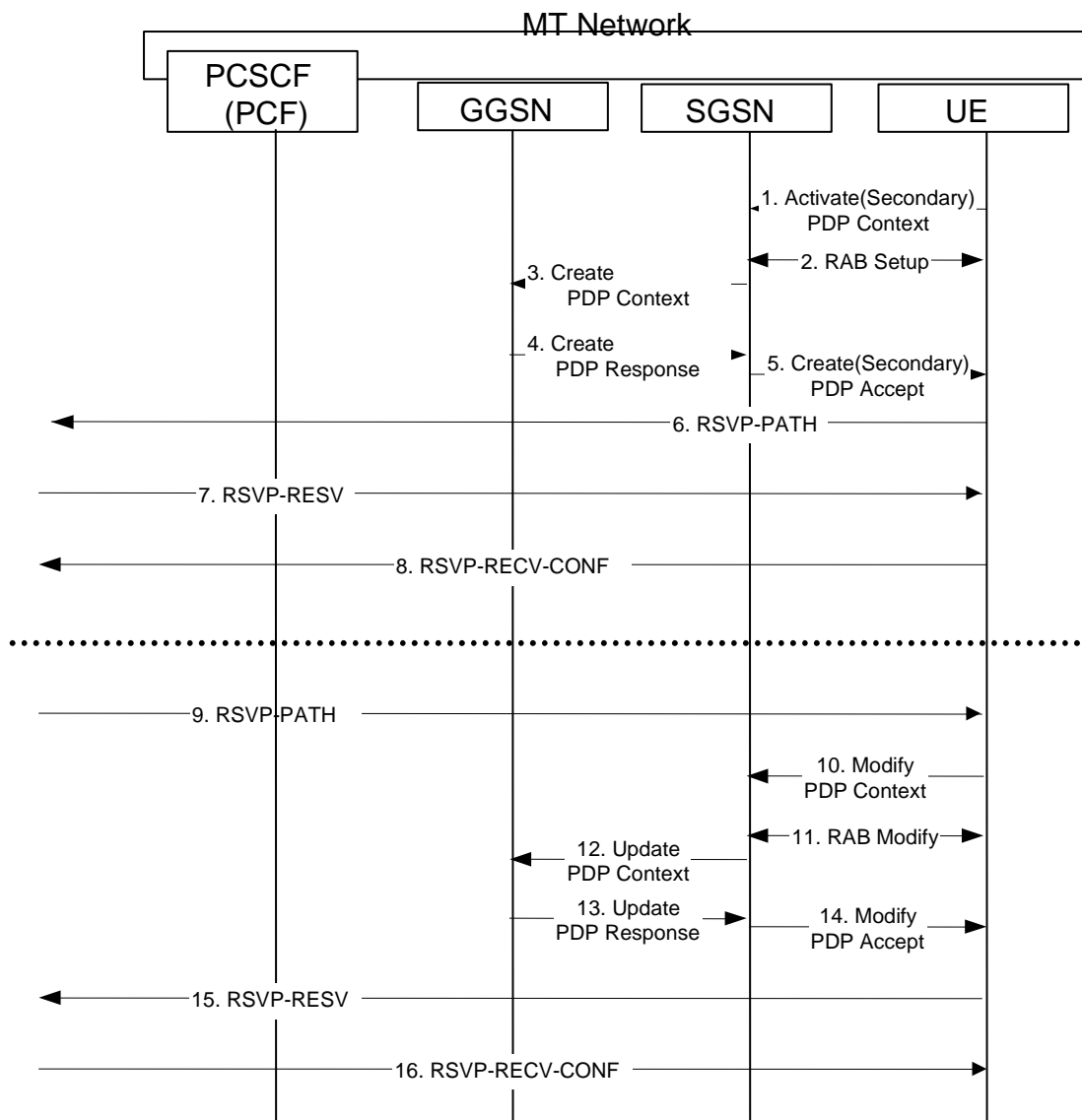

Figure 6: MT Resource Reservation with End-to-End RSVP

Note: There is no timing relationship between the set of flows for the uplink (above the line) and the downlink (below the line).

6.3.2.3 Resource Reservation with End-to-End RSVP and Service-based Local Policy

For this case, Service-based Local Policy and RSVP are added to the GPRS bearer establishment procedures specified in TS23.060.

Note: The diagrams in this subsection depict one possible signalling sequence, however, the alternative signalling sequences below are possible:

- to trigger the Create PDP Context Request message after the PATH message.
- to trigger the Create PDP Context Request message after the RESV message.
- to trigger only one PDP context after all RSVP exchanges have completed.

Note: The diagrams in this subsection depict the case when the GGSN is RSVP aware, however, the alternative of GGSN not being RSVP aware is also possible.

This section provides the flows for bearer establishment, resource reservation and policy control with RSVP.

The following figure is applicable to the Mobile Originating (MO) side.

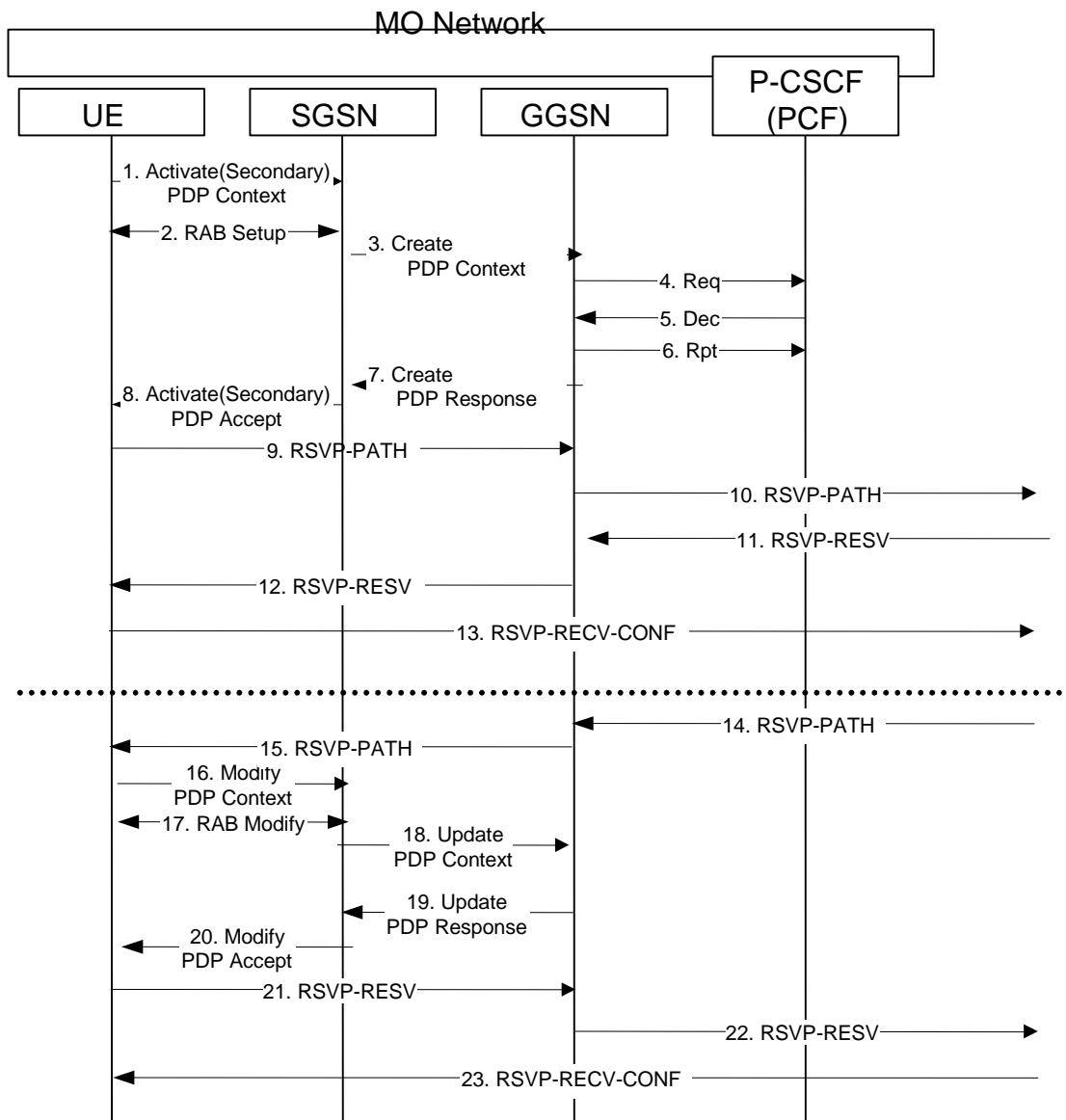

Figure 7: MO Resource Reservation with End-to-End RSVP and Service-based Local Policy

Note: There is no timing relationship between the set of flows for the uplink (above the line) and the downlink (below the line).

1. The UE sends an Activate (Secondary) PDP Context message to the SGSN with the UMTS QoS parameters. The UE includes the Binding Information in the Activate PDP Context message.
2. The radio access bearer (RAB) setup procedure is performed.
3. The SGSN sends the corresponding Create PDP Context message to the GGSN.
4. The GGSN sends a COPS REQ message with the Binding Information to the PCF in order to obtain relevant policy information .

5. The PCF sends a COPS DEC message back to the GGSN.
6. The GGSN sends a COPS RPT message back to the PCF.
7. The GGSN uses the policy information to accept the PDP activation request, and sends a Create PDP Context Response message back to SGSN. The GGSN may cache the policy information.
8. The SGSN sends an Activate (Secondary) PDP Context Accept message to UE.
9. UE sends a RSVP PATH message to GGSN. The UE includes the Binding Information.

Note: If the decision was previously cached locally at the GGSN, it may not be necessary to query the PCF again. Otherwise the GGSN may have to query the PCF.

10. The GGSN uses the policy information to accept the RSVP PATH message, and forwards the RSVP PATH message to the next hop.
11. The GGSN receives the RSVP RESV message in the downlink direction.

Note: If the decision was previously cached locally at the GGSN, it may not be necessary to query the PCF again. Otherwise the GGSN may have to query the PCF.

12. The GGSN uses the policy information to accept the RSVP RESV message, and forwards the RSVP RESV message to the UE.
13. The UE sends a RSVP RESV-CONF message to the next hop. The use of the RESV-CONF message is optional.
14. The GGSN receives a RSVP PATH message in the downlink direction. .
15. The GGSN forwards the RSVP PATH message to the UE.
16. The UE may send a Modify PDP Context message to the SGSN with the necessary modification to UMTS QoS parameters according to the received RSVP PATH message. The UE includes the Binding Information in the Modify PDP Context message.
17. The radio access bearer (RAB) modification procedure is performed.
18. The SGSN sends the corresponding Update PDP Context message to the GGSN.

Note: If the decision was previously cached locally at the GGSN, it may not be necessary to query the PCF again. Otherwise the GGSN may have to query the PCF.

19. The GGSN uses the policy information to accept the PDP modification request, and sends a Update PDP Context Response message back to SGSN.
20. The SGSN sends a Modify PDP Context Accept message to UE.

Note: Steps 16 to 20 are optional if the existing PDP context already satisfies the QoS requirements.

21. The UE sends a RSVP RESV message to the GGSN. The UE includes the Binding Information in the RSVP RESV message.

Note: If the decision was previously cached locally at the GGSN, it may not be necessary to query the PCF again. Otherwise the GGSN may have to query the PCF.

22. The GGSN uses the policy information to accept the RSVP RESV message, and forwards the RSVP RESV message to the next hop.
23. The UE receives the RSVP RESV-CONF message in the downlink direction. The use of the RESV-CONF message is optional.

The following figure is applicable to the Mobile Terminating (MT) side. As the flow is the mirror of the Mobile Originating (MO) side, the step-by-step description is omitted.

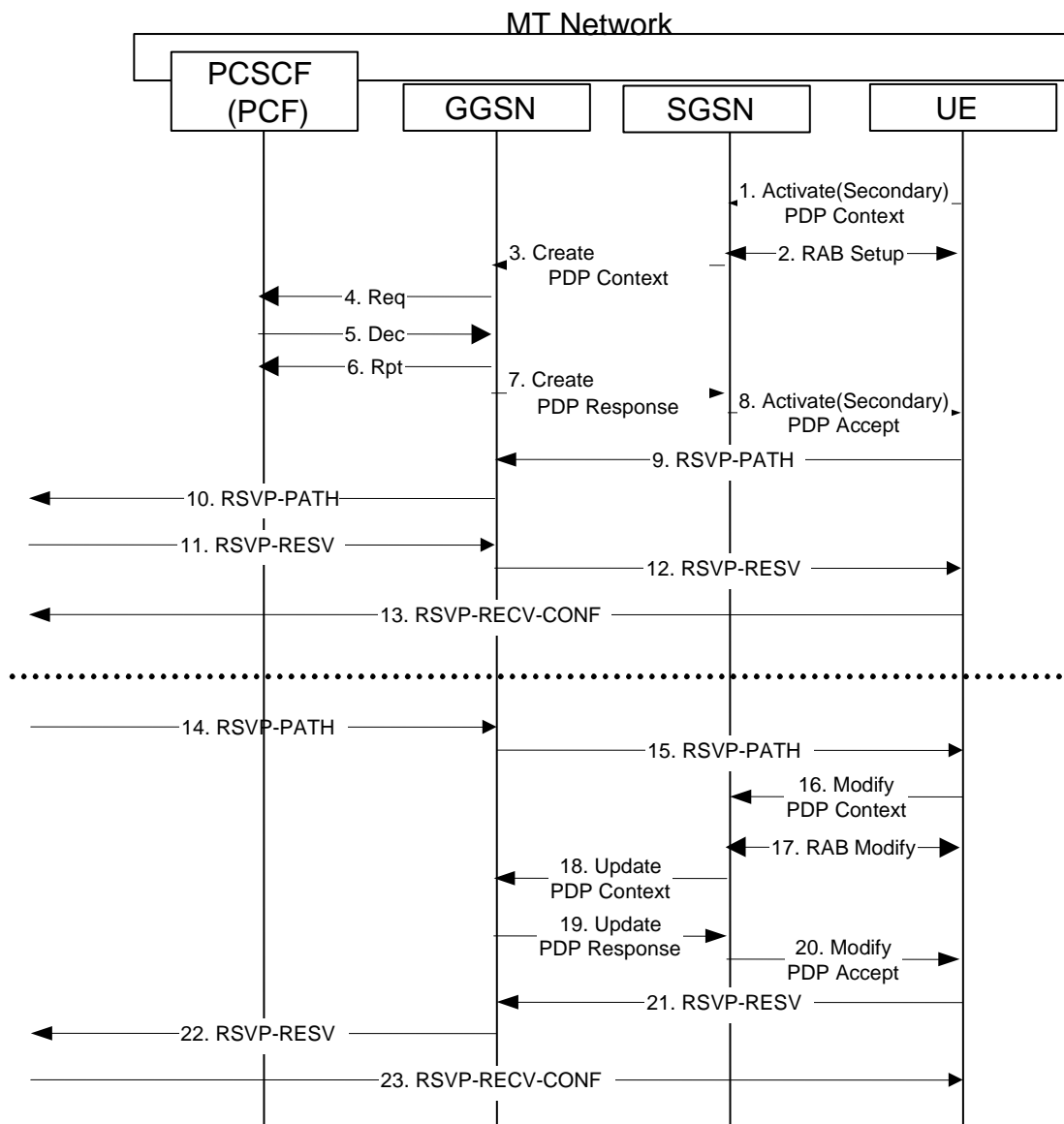

Figure 8: MT Resource Reservation with End-to-End RSVP and Service-based Local Policy

Note: There is no timing relationship between the set of flows for the uplink (above the line) and the downlink (below the line).

6.3.2.4 Service-based Local Policy and RSVP Sender/Receiver Proxy

For this case, Service-based Local Policy and RSVP Sender/Receiver Proxy are added to the GPRS bearer establishment procedures specified in TS23.060.

The SIP QoS precondition met criteria for this case is the successful activation of PDP context, and does not depend on the RSVP aspect. In this case, the use of RSVP may be intended to enable the external network provider to support traffic engineering, efficient resource management, and call blocking if needed to handle temporary overload conditions. If the RSVP setup is unsuccessful, it is operator choice to have for example the GGSN initiate a PDP context deactivation.

This section provides the flows for bearer establishment, resource reservation and policy control with PDP Context setup and RSVP inter-working.

The following figure is applicable to the Mobile Originating (MO) side.

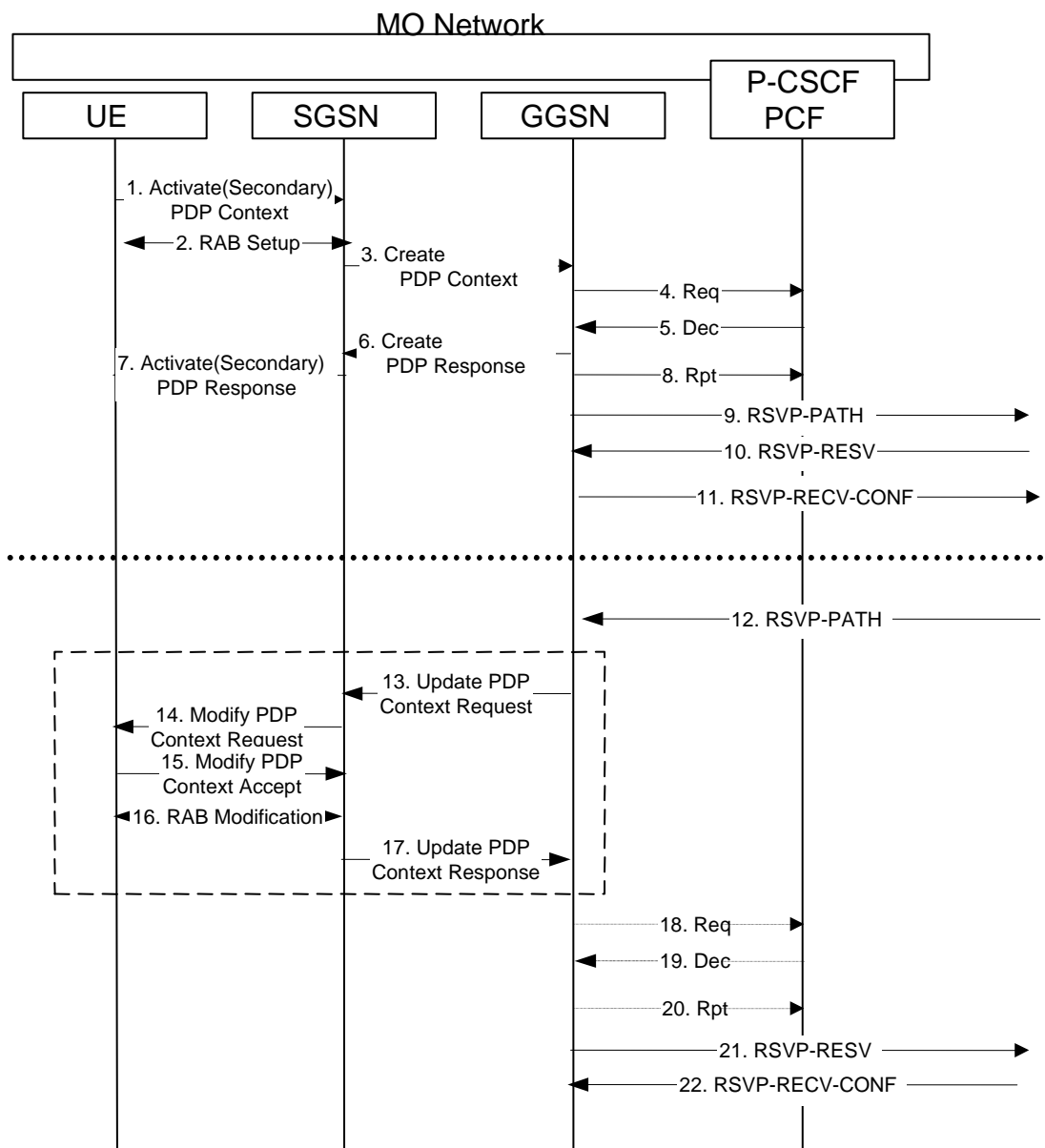

Figure 9: MO Service-based Local Policy and RSVP Sender/Receiver Proxy

Note: There is no timing relationship between the set of flows for the uplink (above the line) and the downlink (below the line).

1. The UE sends an Activate (Secondary) PDP Context message to the SGSN with the UMTS QoS parameters. The UE includes the Binding Information in the Activate (Secondary) PDP Context message.
2. The radio access bearer (RAB) setup procedure is performed.
3. The SGSN sends the corresponding Create PDP Context message to the GGSN.
4. The GGSN sends a COPS REQ message with the Binding Information to the PCF in order to obtain relevant policy information.
5. The PCF sends a COPS DEC message back to the GGSN.
6. The GGSN uses the policy information to accept the PDP activation request, and sends a Create PDP Context Response message back to SGSN.
7. The SGSN sends an Activate (Secondary) PDP Context Accept message to UE.

8. The GGSN sends a COPS RPT message back to the PCF.

Note: Step 8 may also occur at the same time or before step 6 and step 7.

9. The GGSN invokes a RSVP PATH message on behalf of the UE to the next hop. Within the RSVP PATH, the SENDER_TSPEC object is mapped from the UMTS QoS information and the SESSION object is constructed from the 5-tuple session information that is received from the PCF.

10. Upon receiving the RSVP RESV message, the GGSN authorizes it using the local policy information cached in the Local Policy Decision Point.

11. The GGSN sends a RSVP RESV-CONF message to the next hop. The use of the RESV-CONF message is optional.

12. The GGSN receives a RSVP PATH message in the downlink direction and authorizes the incoming RSVP PATH message with the local policy information cached in the LDP. Depending on the information in the TSPEC of the RSVP message, the GGSN will decide if PDP Context modification is needed.

13. If the PDP Context Modification is needed, the GGSN send a network-initiated PDP Context Update message to the SGSN with the necessary modification to UMTS QoS parameters according to the received RSVP PATH message.

14. The SGSN sends the corresponding Modify PDP Context message to the UE.

15. The UE sends a Modify PDP Context Accept message to GGSN. The UE includes the Binding Information in the Modify PDP context Accept message.

16. The radio access bearer (RAB) modification procedure is performed.

17. The SGSN sends the PDP Context Update Response message to the GGSN.

18. The GGSN sends a COPS REQ message with the Binding Information to the PCF in order to obtain relevant policy information.

19. The PCF sends a COPS DEC message back to the GGSN.

20. The GGSN sends a COPS RPT message back to the PCF.

Note: Steps 18, 19, and 20 are optional if the decision was previously cached in the GGSN (PEP).

21. The GGSN sends a RSVP RESV message to the next hop.

22. The GGSN receives the RSVP RESV-CONF message in the downlink direction. The use of the RESV-CONF message is optional.

The following figure is applicable to the Mobile Terminating (MT) side. As the flow is the mirror of the Mobile Originating (MO) side, the step-by-step description is omitted.

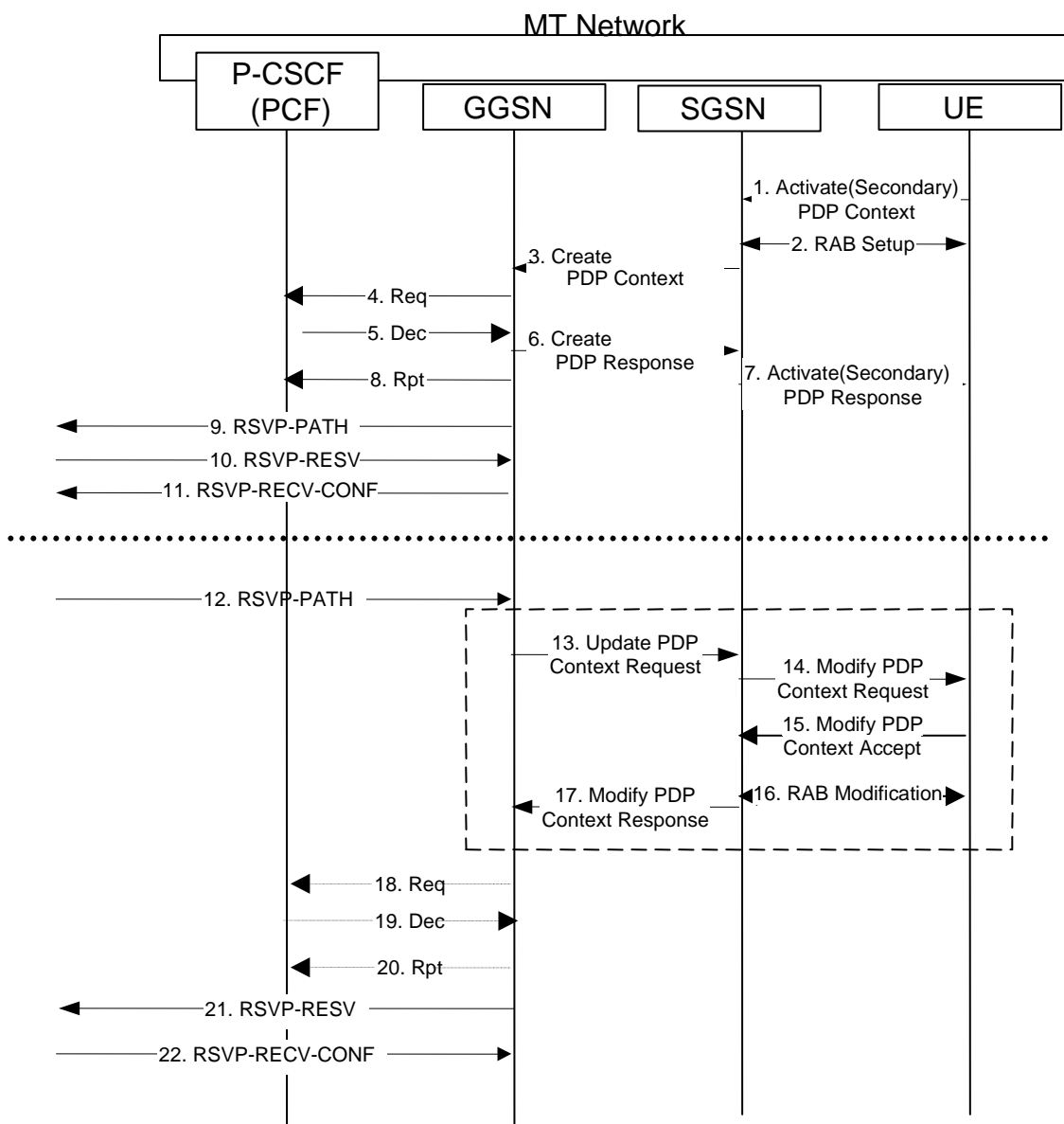

Figure 10: MT Service-based Local Policy and RSVP Sender/Receiver Proxy

Note: There is no timing relationship between the set of flows for the uplink (above the line) and the downlink (below the line).

6.3.3 Approval of QoS Commit

The Approval of QoS Commit procedure is triggered by the P-CSCF receiving a 200 OK message.

The following figure is applicable to both the Mobile Originating (MO) side and the Mobile Terminating (MT) side.

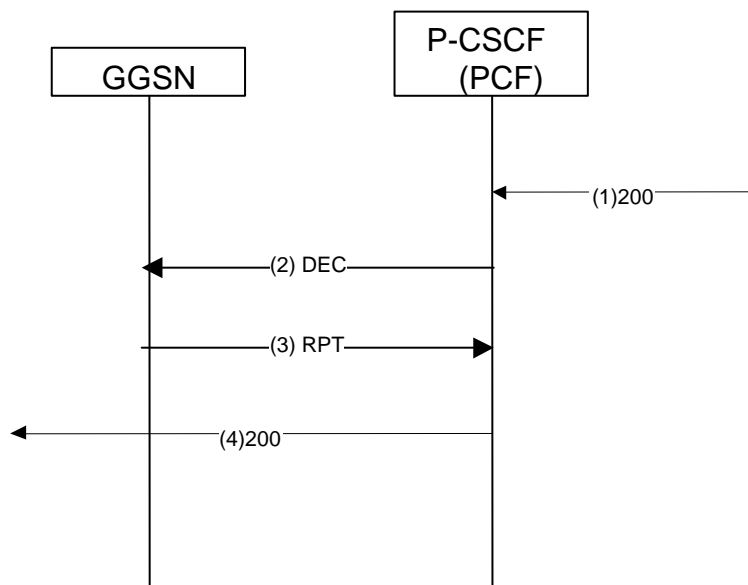

Figure 11: Approval of QoS Commit

1. The P-CSCF receives the 200 OK message. P-CSCF(PCF) approves the QoS Commit.
2. The PCF shall send a COPS DEC message to the GGSN to open the 'gate'.
3. The GGSN receives the COPS DEC message and opens the 'gate' and sends a COPS RPT message back to the PCF.
4. The P-CSCF forwards the 200 OK message to the next hop.

Annex A (Informative): QoS Conceptual Models

A.1 Introduction

There are many different end-to-end scenarios that may occur from a UE connected to a UTMS network. The following examples depict how end-to-end QoS will be delivered for a number of scenarios that are considered to be significant.

In all the scenarios presented below, the network architecture is as shown in Figure A.1 below.

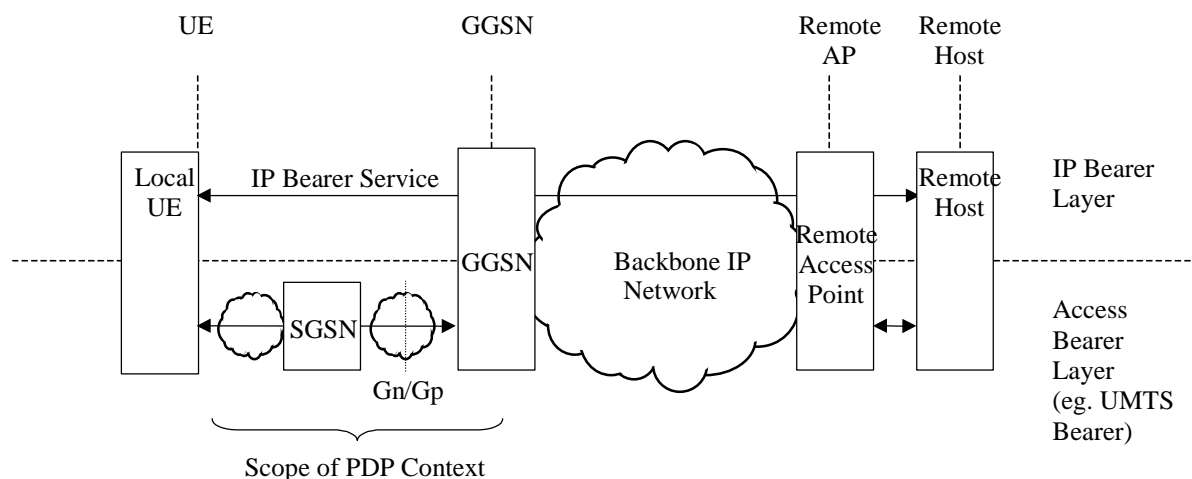

Figure A.1: Network Architecture for QoS Conceptual Models

Notes:

- Although the backbone IP network is shown as a single domain, it may consist of a number of separate domains.
- The structure of the Local UE is not specified. It includes cases from a simple host, to a gateway to a network such as a LAN. If the UE is acting as a gateway, it is responsible for providing the IP BS Management towards the extended network.
- The remote side is shown as a simple host. Other more complex cases on the remote side such as a private LAN with over-provisioning, or possibly LAN priority marking, and DiffServ and/or RSVP capable routing elements is not depicted. It is envisaged however that interworking between the QoS mechanisms in a more complex remote user side could also be performed with some similarities to the mechanisms shown at the local side.

The reference point shown at the UE is at the interface to the UE. Within the UE, the QoS control could be derived from any of the mechanisms that occur across that reference point, or it could use a different mechanism internally.

Although the scenarios currently identified are mainly using DiffServ in the backbone IP network (RSVP is indicated as an alternative in scenario 4), it is not mandated that DiffServ must be used in the backbone IP network. Other mechanisms, for example, over-provisioning and aggregated RSVP may be used.

A.2 Scenarios

[Editorial Note: the precedence and sequence of the different phases of session / bearer establishment need further study.]

These scenarios give examples of concatenating QoS mechanisms in different parts of the network which together can deliver an end-to-end QoS. These scenarios are not intended to describe the details of the interworking between the QoS mechanisms.

The different scenarios involve cases with and without service based local policy. Each scenario describes the applicable cases, possibly by referencing another scenario. In some scenarios, only one of the cases may be valid (e.g. scenarios 5 and 6). Where both cases are covered, they may be described together identifying the optionality, or separately for clarity of the individual cases.

The optional authorisation token is associated with the cases involving service based local policy, and is applicable for IM services. It is an operator decision whether or not to support service based local policy for IM services. If service

based local policy is not supported, or not applicable (i.e. not IM service), then the optional authorisation token and application server at the P-CSCF are not used.

IM services not using service based local policy will typically follow scenarios 1 to 4. IM services using service based local policy will typically follow scenarios 3 to 6.

NOTE: Scenario 5 and 6 is reserved for the IP multimedia services involving, e.g., SIP signalling, IP policy control, and subscription checking.

A.2.1 Scenario 1

The UE does not provide an IP BS Manager. The end-to-end IP QoS bearer service towards the remote terminal is controlled from the GGSN.

The scenario assumes that the GGSN supports DiffServ edge functions, and the backbone IP network is DiffServ enabled.

NOTE: The UE may always include an authorisation token in establishment of the PDP context. Inclusion of the authorisation token in scenario 1 changes the QoS mechanisms to be the same as those described in scenario 5. Therefore, please refer to scenario 5 if the authorisation token is included.

The application layer (e.g. SIP/SDP) between the end hosts identifies the QoS requirements. The QoS requirements determined from the application layer (e.g. TS23.228 describes interworking from SIP/SDP to QoS requirements) are mapped down to PDP context parameters in the UE.

In this scenario, the control of the QoS over the UMTS access network (from the UE to the GGSN) may be performed either from the terminal using the PDP context signalling, or from the SGSN by subscription data.

The IP QoS for the downlink direction is controlled by the remote terminal up to the GGSN. The GGSN will apply receiver control DiffServ edge functions and can reclassify the data (remarking the DiffServ Code Point (DSCP)). This may affect the QoS applied to the data over the UMTS access (the TFT may use the DSCP to identify the data to be allocated to the PDP context).

The end-to-end QoS is provided by a local mechanism in the UE, the PDP context over the UMTS access network, DiffServ through the backbone IP network, and DiffServ in the remote access network in the scenario shown in the figure below. The GGSN provides the interworking between the PDP context and the DiffServ function. However, the interworking may use information about the PDP context which is established, or be controlled from static profiles, or dynamically through other means such as proprietary HTTP based mechanisms. The UE is expected to be responsible for the control of the PDP context, but this may instead be controlled from the SGSN by subscription.

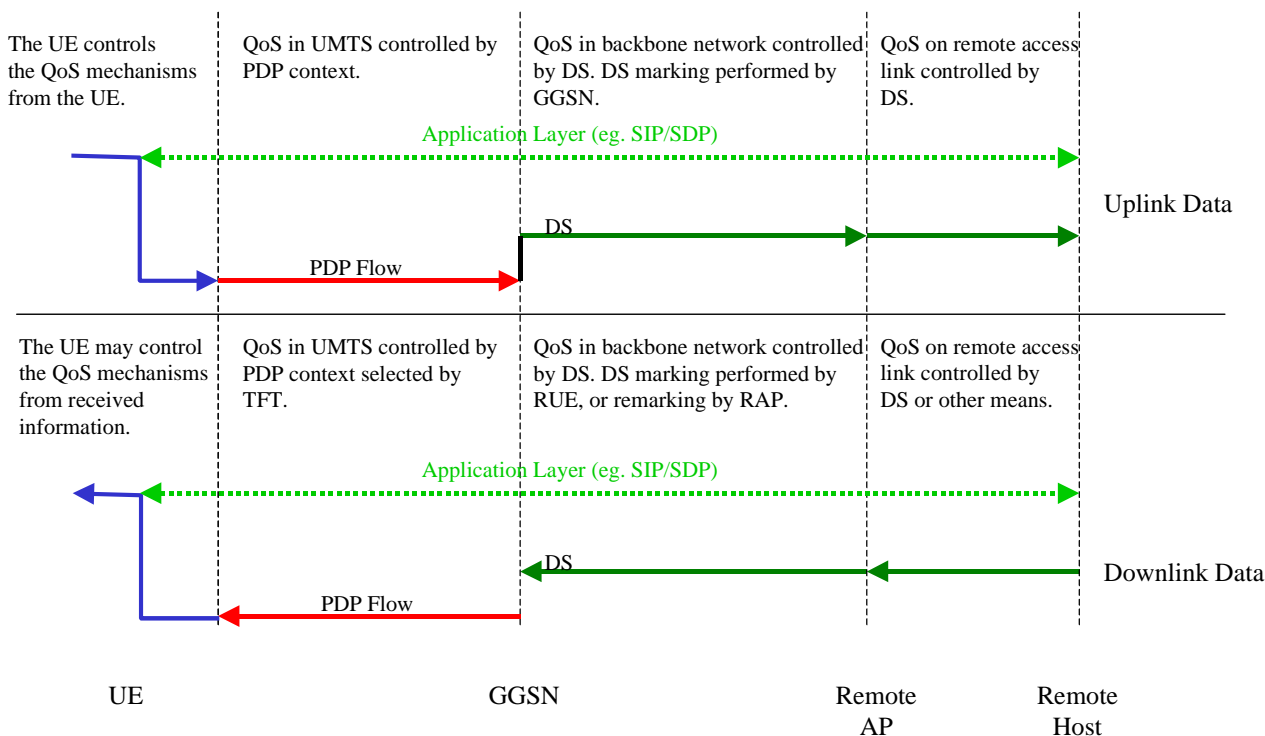

Figure A.2: Local UE does not provide IP BS Manager

Notes:

- The solid horizontal lines indicate the mechanism that is providing QoS for the flow of data in the direction indicated.
 - The dashed horizontal lines indicate where QoS control information is passed that is not directly controlling the QoS in that link/domain.
 - The arrows on the horizontal lines indicate nodes that receive information about QoS from that mechanism, even if that mechanism is not used to control the QoS over that link/domain.
 - The solid vertical lines indicate interworking between the different mechanisms.
- In the figure, the term RAP refers to the Remote Access Point, and RUE is the Remote UE.

No solid vertical line is shown from DiffServ to PDP flow on the downlink at the GGSN. The TFT determines the QoS applicable over the UMTS access. However, the configuration of the TFT may use the DiffServ to select the PDP context to be applied, so there may be interworking between DiffServ and the PDP Flow via the TFT filters.

A.2.2 Scenario 2

The UE performs an IP BS function which enables end-to-end QoS without IP layer signalling towards the IP BS function in the GGSN, or the remote terminal.

The scenario assumes that the UE and GGSN support DiffServ edge functions, and that the backbone IP network is DiffServ enabled.

NOTE: The UE may always include an authorisation token in establishment of the PDP context. Inclusion of the authorisation token in scenario 2 changes the QoS mechanisms to be the same as those described in scenario 5. Therefore, please refer to scenario 5 if the authorisation token is included.

The application layer (e.g. SIP/SDP) between the end hosts identifies the QoS needs. The QoS requirements from application layer (e.g. TS23.228 describes interworking from SIP/SDP to QoS requirements) are mapped down to the IP layer. The IP layer service requirements are further mapped down to the PDP context parameters in the UE.

In this scenario, the control of the QoS over the UMTS access network (from the UE to the GGSN) may be performed either from the terminal using the PDP context signalling. Alternatively, subscription data accessed by the SGSN may override the QoS requested via signalling from the UE (according to the procedures specified in TS 23.060).

In this scenario, the terminal supports DiffServ to control the IP QoS through the backbone IP network.

The IP QoS for the downlink direction is controlled by the remote terminal up to the GGSN. The PDP context controls the QoS between the GGSN and the UE. The UE may apply DiffServ edge functions to provide the DiffServ receiver control. Otherwise, the DiffServ marking from the GGSN will determine the IP QoS applicable at the UE.

The end-to-end QoS is provided by a local mechanism in the UE, the PDP context over the UMTS access network, DiffServ through the backbone IP network, and DiffServ in the remote access network in the scenario shown in the figure below. The UE provides control of the DiffServ, and therefore determines the appropriate interworking between the PDP context and DiffServ.

The GGSN DiffServ edge function may overwrite the DSCP received from the UE, possibly using information regarding the PDP context which is signalled between the UMTS BS managers and provided through the translation/mapping function to the IP BS Manager.

Note that DiffServ control at the Remote Host is shown in this example. However, other mechanisms may be used at the remote end, as demonstrated in the other scenarios.

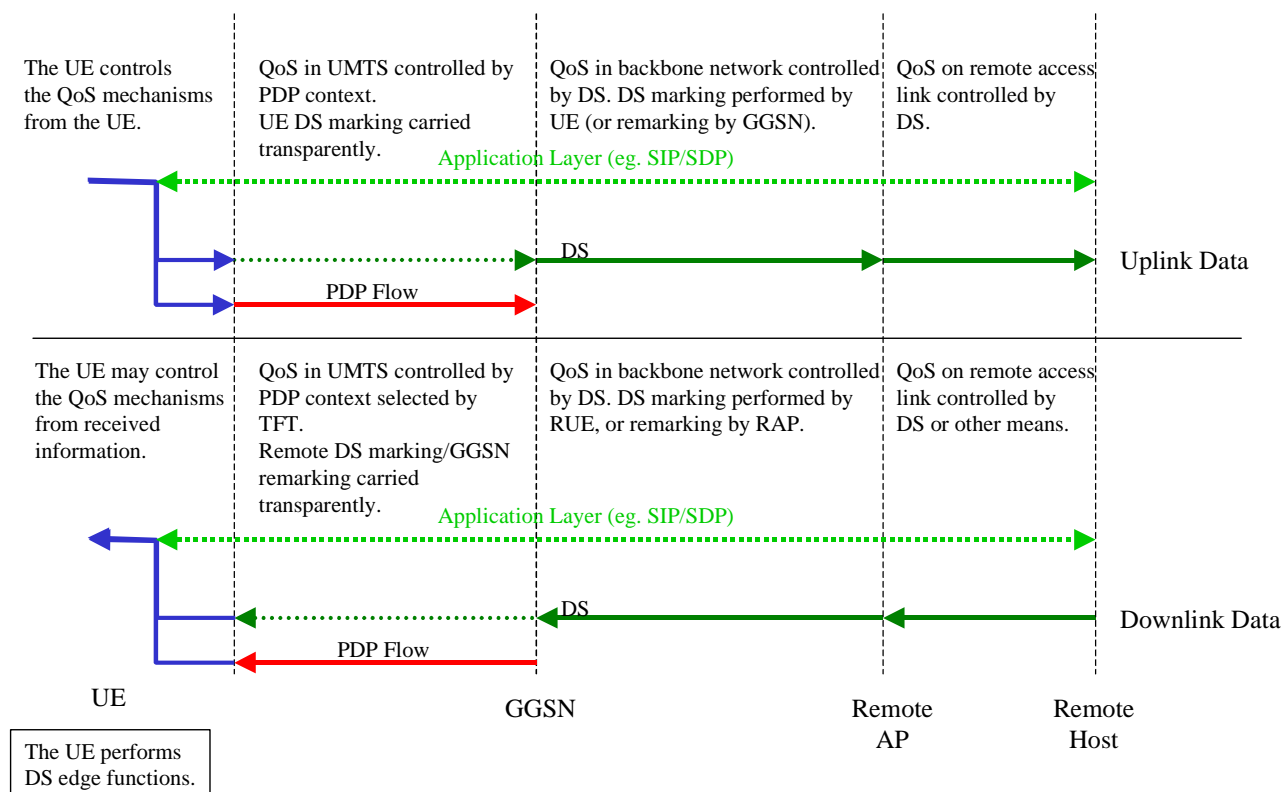

Figure A.3 Local UE supports DiffServ

A.2.3 Scenario 3

The UE performs an IP BS function which enables end-to-end QoS using IP layer signalling towards the remote end. There is no IP layer signalling between the IP BS Managers in the UE and the GGSN. However, the GGSN may make

use of information regarding the PDP context which is signalled between the UMTS BS managers and provided through the translation/mapping function.

This scenario assumes that the UE and GGSN support DiffServ edge functions, and that the backbone IP network is DiffServ enabled. In addition, the UE supports RSVP signalling which interworks within the UE to control the DiffServ.

The application layer (e.g. SIP/SDP) between the end hosts identifies the QoS requirements. The QoS requirements from application layer (e.g. TS23.228 describes interworking from SIP/SDP to QoS requirements) are mapped down to create an RSVP session. The UE shall establish the PDP context suitable for support of the RSVP session. The authorisation token from the application layer when included shall be mapped to the corresponding RSVP signalling parameters as well as the PDP context parameters.

In this scenario, the control of the QoS over the UMTS access network (from the UE to the GGSN) may be performed either from the terminal using the PDP context signalling. Alternatively, subscription data accessed by the SGSN may override the QoS requested via signalling from the UE (according to the procedures specified in TS 23.060).

In this scenario, the terminal supports signalling via the RSVP protocol to control the QoS at the local and remote accesses, and DiffServ to control the IP QoS through the backbone IP network. The RSVP signalling protocol may be used for different services. It is expected that only RSVP using the Integrated Services (IntServ) semantics would be supported, although in the future, new service definitions and semantics may be introduced. The entities that are supporting the RSVP signalling should act according to the IETF specifications for IntServ and IntServ/DiffServ interwork.

The QoS for the wireless access is provided by the PDP context. The UE may control the wireless QoS through signalling for the PDP context. The characteristics for the PDP context may be derived from the RSVP signalling information, or may use other information.

QoS for the IP layer is performed at two levels. The end-to-end QoS is controlled by the RSVP signalling. Although RSVP signalling can be used end-to-end in the QoS model, it is not necessarily supported by all intermediate nodes. Instead, DiffServ is used to provide the QoS throughout the backbone IP network.

At the UE, the data is also classified for DiffServ. Intermediate QoS domains may apply QoS according to either the RSVP signalling information or DiffServ mechanisms. In this scenario, the UE is providing interworking between the RSVP and DiffServ domains. The GGSN may override the DiffServ setting from the UE. This GGSN may use information regarding the PDP context in order to select the appropriate DiffServ setting to apply, as shown in the figure below.

The end-to-end QoS is provided by a local mechanism in the UE, the PDP context over the UMTS access network, DiffServ through the backbone IP network, and DiffServ in the remote access network in the scenario shown in the figure below. The RSVP signalling may control the QoS at both the local and remote accesses. This function may be used to determine the characteristics for the PDP context, so the UE may perform the interwork between the RSVP signalling and PDP context.

The UE provides control of the DiffServ (although this may be overwritten by the GGSN), and in effect, determines the appropriate interworking between the PDP context and DiffServ.

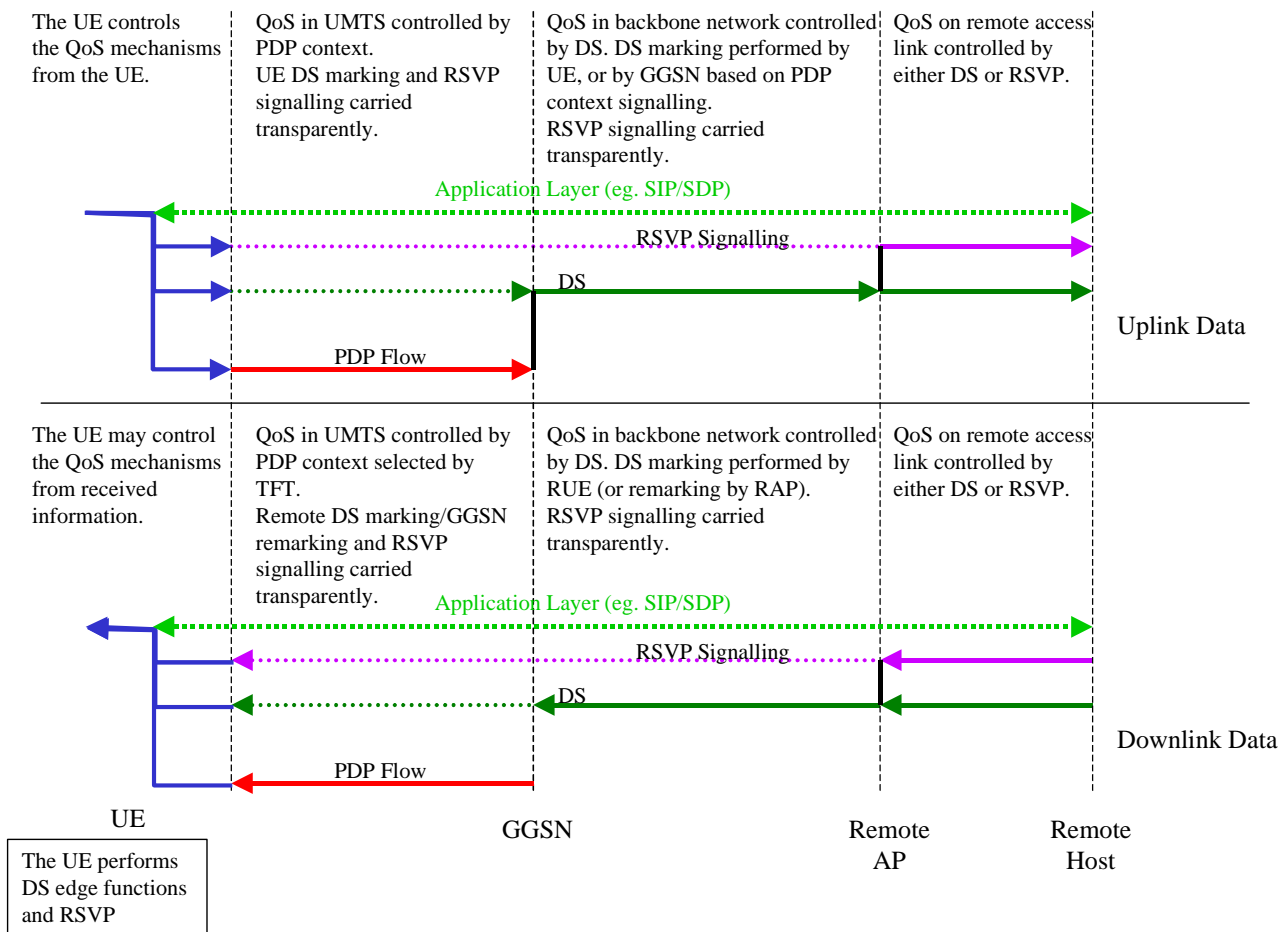

Figure A.4: Local UE supports RSVP signalling with IntServ semantics, and DiffServ; without service based policy

When the authorisation token is included in the PDP context establishment/modification (as per section 5.1.1.2.3), the GGSN may use IP level information provided by service based local policy according to the authorisation token to configure the DiffServ classifier functionality. The information can also be used for DiffServ class admission control, e.g., the requested end-to-end bandwidth from the UE for a particular flow may be informed to the GGSN beforehand for the GGSN DiffServ edge to determine if the flow can be allowed to a certain DiffServ class or to/from an ingress/egress point.

The application layer signaling may be processed in the local network at an application server such as the P-CSCF in the case of SIP signaling. Interworking between the GGSN and the application layer is shown as a vertical line where applicable. This interworking is for policy control and is between the GGSN and the PCF policy function co-located in the P-CSCF, as shown in the figure below.

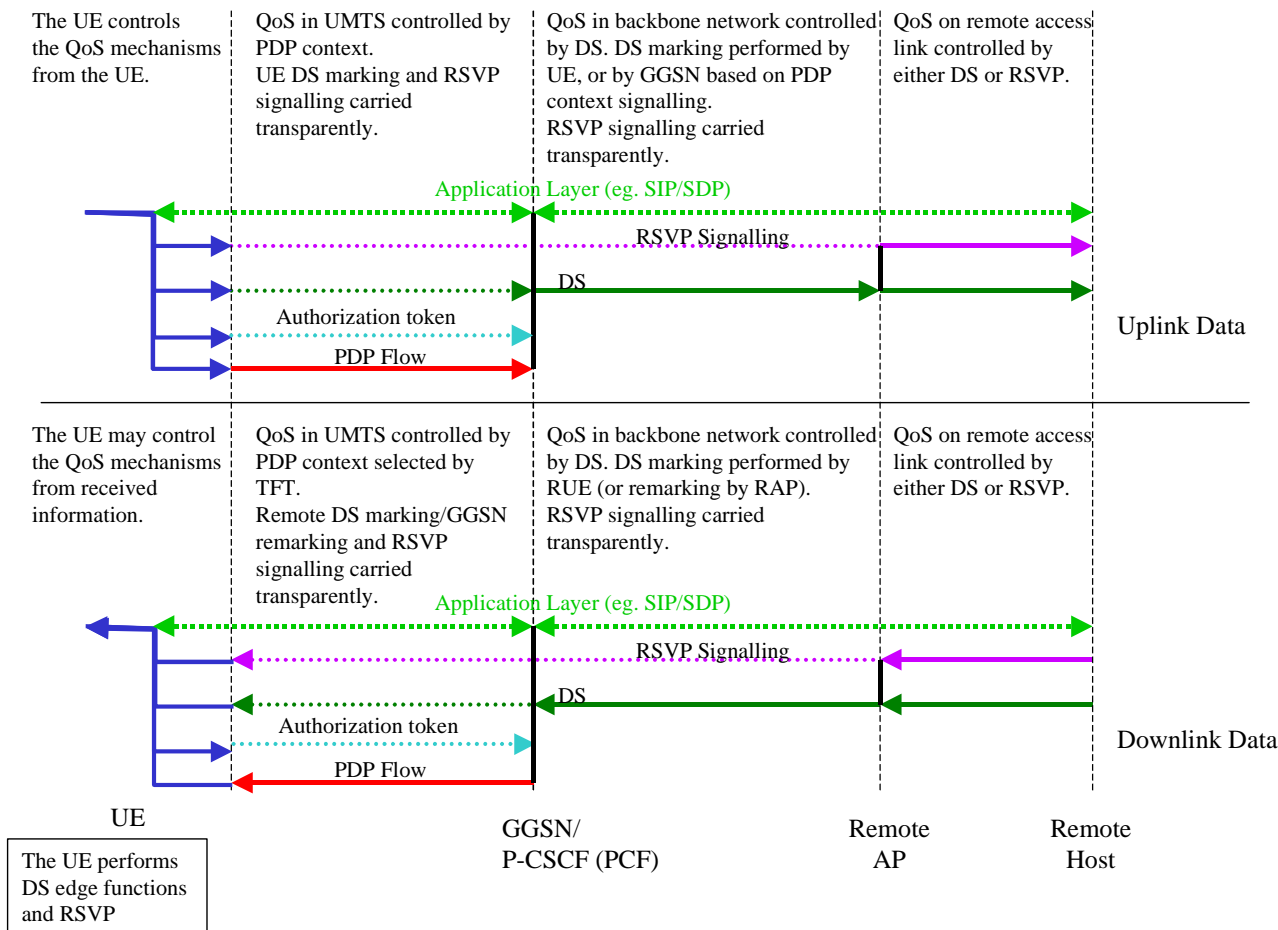

Figure A.5: Local UE supports RSVP signalling with IntServ semantics, and DiffServ; where service based policy is applied

A.2.4 Scenario 4

The UE performs an IP BS function which enables end-to-end QoS using IP layer signalling towards the remote end. However, the UE relies on this end-to-end communication being utilised by at least the access point (GGSN) in order to provide the end-to-end QoS.

This scenario assumes that the UE and GGSN support RSVP signalling which may control the QoS directly, or interwork with DiffServ. The backbone IP network is RSVP and/or DiffServ enabled.

The application layer (e.g. SIP/SDP) between the end hosts identifies the QoS requirements. The QoS requirements from application layer (e.g. TS23.228 describes interworking from SIP/SDP to QoS requirements) are mapped down to create an RSVP session. The UE shall establish the PDP context suitable for support of the RSVP session. The authorisation token from the application layer shall be mapped to the corresponding RSVP signalling parameters and the PDP context parameters.

In this scenario, the terminal supports signalling via the RSVP protocol to control the QoS across the end-to-end path. The GGSN also supports the RSVP signalling, and uses this information rather than the PDP context to control the QoS through the backbone IP network. The control of the QoS through the core is expected to be supported through interworking with DiffServ at the GGSN, although it may optionally be supported by per flow resource reservation. The RSVP signalling protocol may be used for different services. It is only expected that only RSVP using the Integrated Services (IntServ) semantics would be supported, although in the future, new service definitions and semantics may be introduced. The entities that are supporting the RSVP signalling may fully support the specifications for IntServ and IntServ/DiffServ interwork. If not, they are expected to set the break bit.

In this scenario, the control of the QoS over the UMTS access network (from the UE to the GGSN) may be performed either from the terminal using the PDP context signalling. Alternatively, subscription data accessed by the SGSN may override the QoS requested via signalling from the UE (according to the procedures specified in TS 23.060).

QoS for the IP layer is performed at two levels. The end-to-end QoS is controlled by the RSVP signalling. Although RSVP signalling occurs end-to-end in the QoS model, it is not necessarily supported by all intermediate nodes. DiffServ is used to provide the QoS throughout the backbone IP network, although optionally each node may support RSVP signalling and allocation of resources per flow. An authorisation token may be included in the RSVP signalling and the PDP context establishment/modification. The GGSN may use IP level information provided by service based local policy according to the authorisation token to authorise the RSVP session and configure the Diffserv classifier functionality. The information may also be used in conjunction with a Diffserv aggregate to enable DiffServ class admission control, e.g., the requested end-to-end bandwidth from the UE for a particular flow may be informed to the GGSN beforehand for the GGSN DiffServ edge to determine if the flow can be allowed to a certain DiffServ class or to/from an ingress/egress point.

The GGSN supports the RSVP signalling and acts as the interworking point between RSVP and DiffServ. Intermediate QoS domains may apply QoS according to either the RSVP or DiffServ mechanisms.

The end-to-end QoS is provided by a local mechanism in the UE, the PDP context over the UMTS access network, DiffServ through the backbone IP network, and RSVP in the remote access network in the scenario shown in the figure below. The RSVP signalling may control the QoS at the local access. This function may be used to determine the characteristics for the PDP context, so the UE may perform the interwork between RSVP and the PDP context.

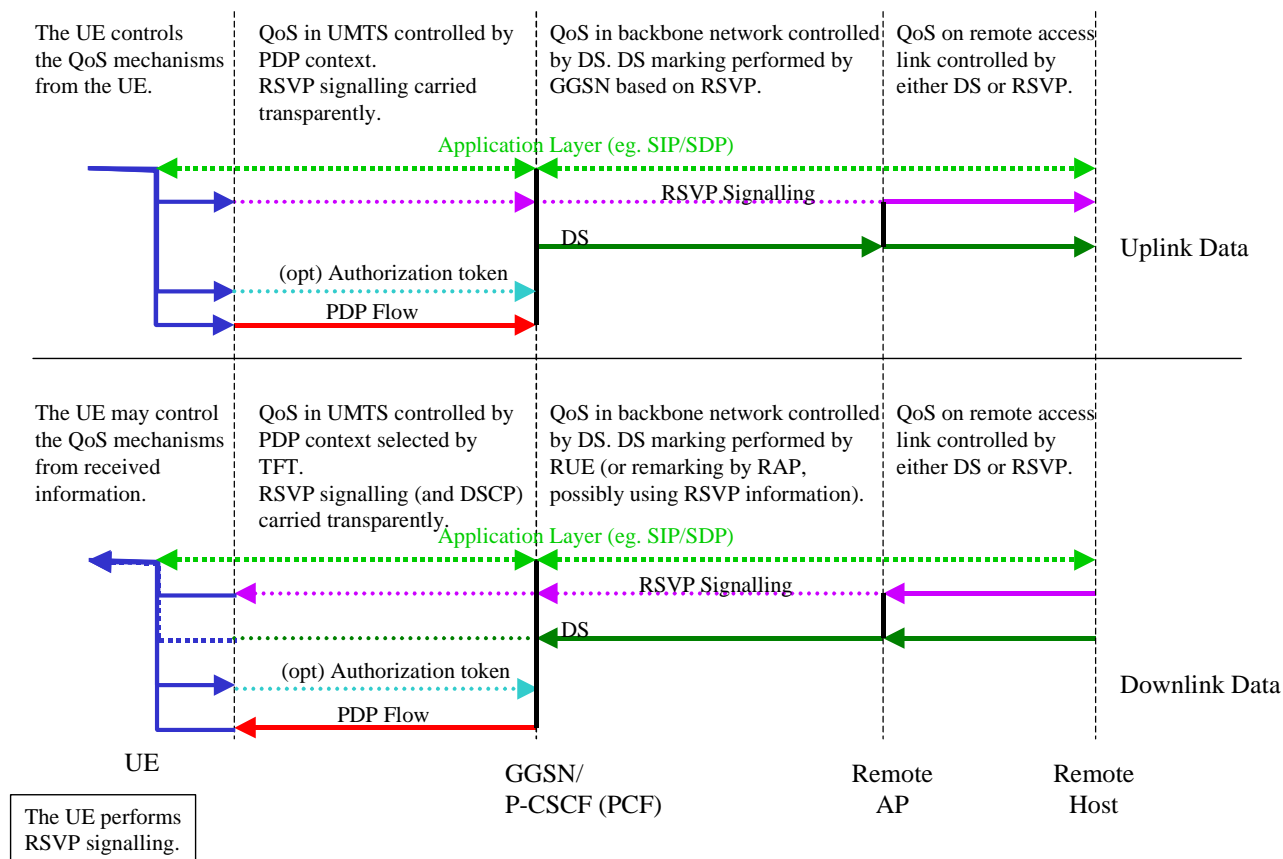

Figure A.6: Local UE supports RSVP signalling using IntServ Semantics

A.2.5 Scenario 5

The UE performs an IP BS function which enables end-to-end QoS without IP layer signalling and negotiation towards the IP BS function in the GGSN, or the remote host. The P-CSCF provides the authorization token to the UE during the SIP session setup process, and the UE provides the authorization token to the GGSN in the PDP context activation/modification message, to enhance the interworking options to the DiffServ edge function of the GGSN. The GGSN uses the authorization token to obtain a policy decision from the P-CSCF(PCF) which will be used to derive IP

level information. This is done via the standardized interface between the PCF and GGSN. Even if the interface is an open interface where all information elements are standardized, the actual usage of the information is operator specific.

In addition, IP level information may also be derived from PDP context (e.g. QoS parameters).

The scenario assumes that the GGSN support DiffServ edge functions, and that the backbone IP network is DiffServ enabled.

The application layer (e.g. SIP/SDP) between the end hosts identifies the QoS needs. The QoS requirements from application layer (e.g. TS23.228 describes interworking from SIP/SDP to QoS requirements) are mapped down to the IP layer and further down to the PDP context parameters in the UE. The authorisation token from the application layer is included in the PDP context parameters by the UE.

The GGSN DiffServ edge function may use the IP level information (e.g., 5-tuple combination of source and destination IP address, source and destination port number, and the protocol identifier) provided by service based local policy according to the authorisation token to configure the DiffServ classifier functionality. The information can be used for DiffServ class admission control, e.g., for the GGSN DiffServ edge to determine if the flow can be allowed to a certain DiffServ class or to/from an ingress/egress point. As a result, the GGSN may select the appropriate DiffServ setting to apply. This is shown in the figure below.

In this scenario, the control of the QoS over the UMTS access network (from the UE to the GGSN) may be performed from the terminal using the PDP context signalling. Alternatively, subscription data accessed by the SGSN may override the QoS requested via signalling from the UE (according to the procedures specified in TS 23.060).

The QoS for the downlink direction is controlled by the remote host from the remote network to the GGSN. The PDP context controls the UMTS level QoS between the GGSN and the UE. The QoS in the uplink direction is controlled by the PDP context up to the GGSN. The GGSN uses the IP level information to interwork with DiffServ in the backbone IP network and control the IP QoS bearer service towards the remote -host.

The end-to-end QoS is provided by a local mechanism in the UE, the PDP context over the UMTS access network, DiffServ through the backbone IP network, and DiffServ in the remote access network. Note that DiffServ control at the Remote Host is shown in this example. However, other mechanisms may be used at the remote end, as demonstrated in the other scenarios.

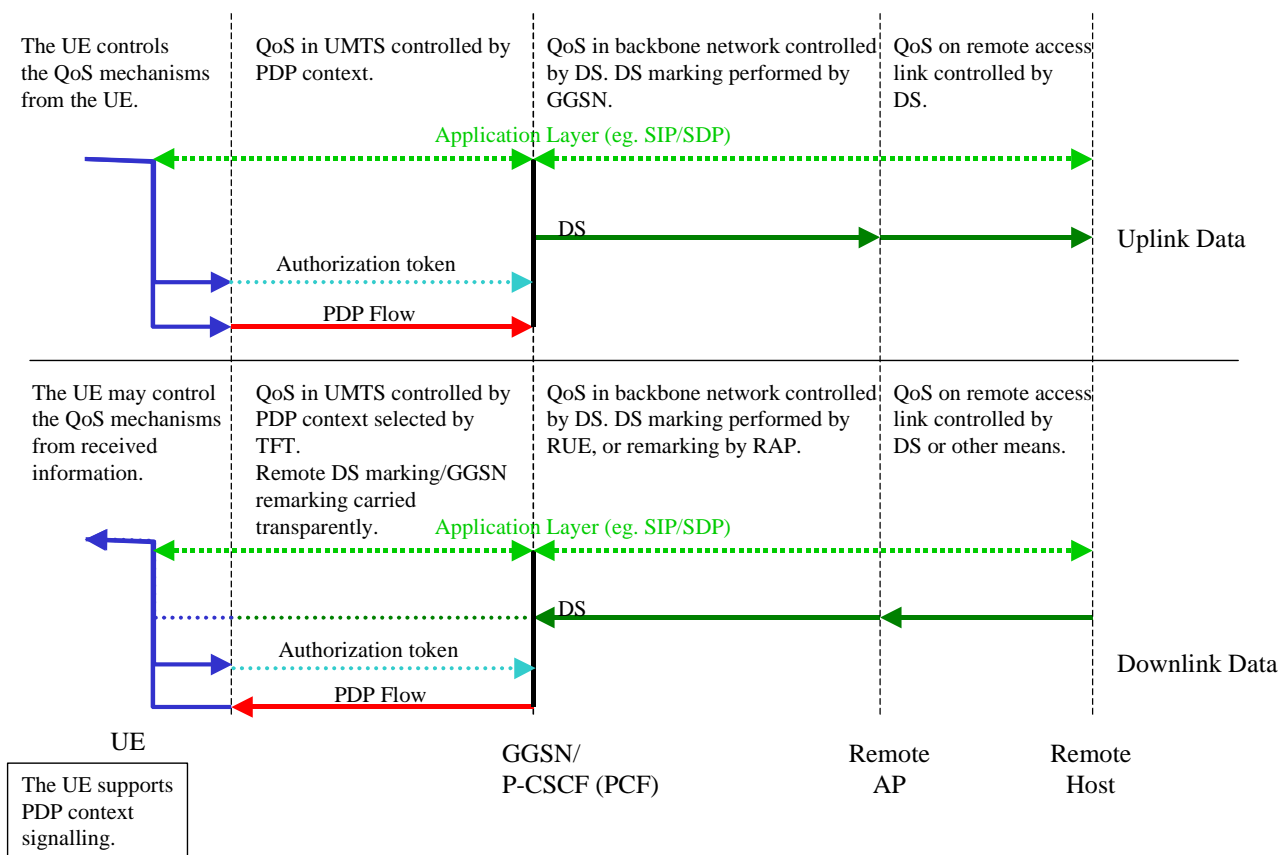

Figure A.7: Local UE provides authorization token in PDP context activation/modification message and GGSN provides interworking with DiffServ

A.2.6 Scenario 6

The UE performs an IP BS function which enables end-to-end QoS without IP layer signalling and negotiation towards the IP BS function in the GGSN, or the remote host. The P-CSCF provides the authorization token to the UE during the SIP session setup process, and the UE provides the authorization token to the GGSN in the PDP context activation/modification message, to enhance the interworking options to an RSVP function in the GGSN. The IP QoS bearer service towards the remote host is controlled from the GGSN.

The GGSN uses the authorization token to obtain a policy decision from the P-CSCF(PCF) which will be used to derive IP level information (e.g. destination IP address, TSpec, FilterSpec, PolicyData). This is done via the standardized interface between the PCF and GGSN. Even if the interface is an open interface where all information elements are standardized, the actual usage of the information is operator specific.

In addition, IP level information may also be derived from PDP context (e.g. QoS parameters).

The scenario assumes that the GGSN supports DiffServ edge functions, and the backbone IP network is DiffServ enabled. This scenario does not preclude the backbone IP network from having RSVP non-transparent routers.

The application layer (e.g. SIP/SDP) between the end hosts identifies the QoS needs. The QoS requirements from application layer (e.g. TS23.228 describes interworking from SIP/SDP to QoS requirements) are mapped down to the IP layer and further down to the PDP context parameters in the UE. The authorization token from the application layer is included in the PDP context parameters by the UE.

The GGSN may use the IP level information to invoke RSVP messages to setup the uplink as well as the downlink flows in the backbone IP network up to the remote host. For example, in the uplink direction, the GGSN may use the IP level information provided by service based local policy according to the authorization token to generate the RSVP Path messages, with the desired QoS / traffic specification, to the specified destination IP address. The information can also be used for DiffServ class admission control, e.g., for the GGSN DiffServ edge to determine if the flow can be allowed to a certain DiffServ class or to/from an ingress/egress point. Also, the GGSN DiffServ edge function may use the IP level information to select the appropriate DiffServ setting to apply. This is shown in the figure below.

In the uplink direction, the GGSN acts as a RSVP Sender Proxy and originates the Path message on behalf of the UE. It must also periodically refresh the Path message and correctly terminate the Resv, ResvTear and PathErr messages for the session.

In the downlink direction, the GGSN acts as a RSVP Receiver Proxy and generates the Resv message on behalf of the UE. The GGSN should install a Resv Proxy state and act as if it has received a Resv from the true endpoint (UE). This involves reserving resource (if required), sending periodic refreshes of the Resv message and tearing down the reservation if the Path is torn down.

The decision on whether to proxy a RSVP session may be done under policy control. Policy control can be performed using policy that has either been locally specified or specified by a policy server via a protocol such as COPS for RSVP

In this scenario, the control of the QoS over the UMTS access network (from the UE to the GGSN) may be performed from the terminal using the PDP context signalling. Alternatively, subscription data accessed by the SGSN may override the QoS requested via signalling from the UE (according to the procedures specified in TS 23.060).

The QoS for the downlink direction is controlled by the PDP context between the UE and the GGSN. The GGSN terminates the RSVP signalling received from the remote host, and may use the IP level information when processing RSVP. The QoS in the uplink direction is controlled by the PDP context up to the GGSN. The GGSN may use the IP level information to provide the interworking with RSVP towards the remote host. The IP level information may allow for the establishment of the RSVP session.

The end-to-end QoS is provided by a local mechanism in the UE, the PDP context over the UMTS access network, DiffServ through the backbone IP network, and RSVP in the remote access network.

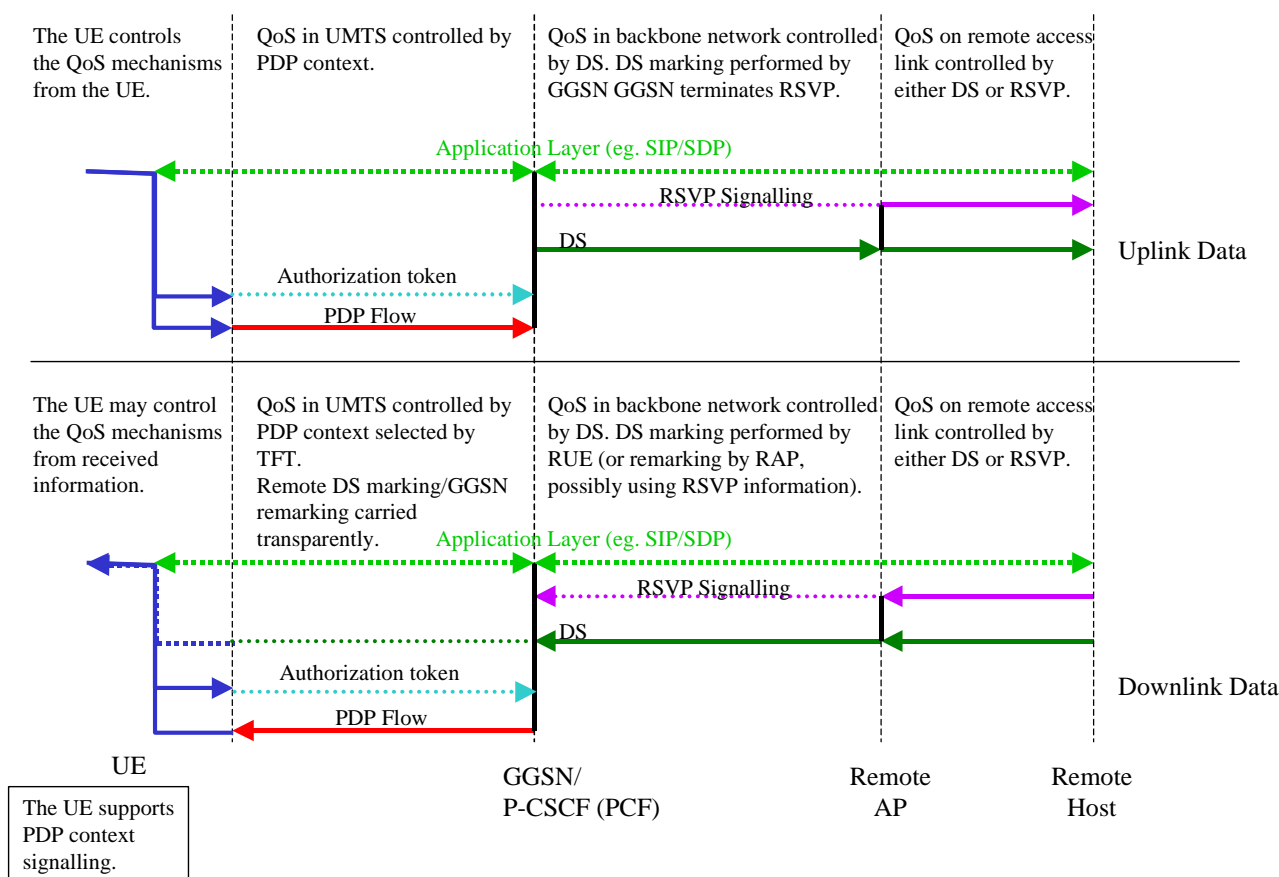

Figure A.8: Local UE provides authorization token in PDP context activation/modification message and GGSN provides interworking with RSVP

Annex B (Informative): Session Flow: QoS Interaction Procedures – Disabling media stream, Revoke Authorization for UMTS and IP resources, Indication of PDP context release

[Editors note: The consistency of the sub-procedure blocks presented here and session flows in TS23.228 shall be taken into account before moving text to the normative part.]

B.1 Disabling media stream

The “Disabling media stream” procedure is used e.g. when a media component of a session is put on hold. (e.g. in case of a media re-negotiation or call hold). The P-CSCF (PCF) provides final decision on disabling media stream for the authorized media stream to the GGSN. The PCF decision of “Disabling media stream” shall be sent as a separate decision to the GGSN corresponding to the previous “Authorize QoS Resources” request.

The GGSN closes the gate, and the media flow will be blocked.

The following figure presents the “Disabling media stream” procedure.

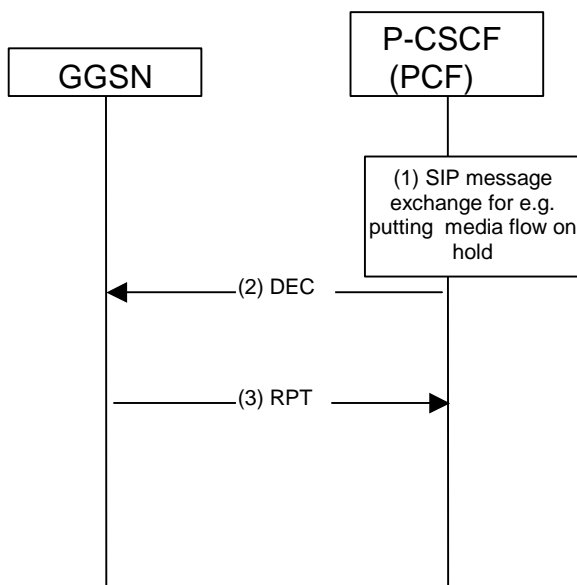

Figure B.1: Disabling media stream

1. SIP message exchanges for e.g., putting a media flow on hold are carried out.
2. The PCF shall send a COPS DEC message to the GGSN to close the ‘gate’.
3. The GGSN receives the COPS DEC message, closes the gate, and sends a COPS RPT message back to the PCF.

B.2 Revoke Authorization for UMTS and IP Resources

The “Revoke Authorization for UMTS and IP resources” procedure is used e.g. upon session release. The PCF decision of “Revoke Authorization for UMTS and IP Resources” shall be sent as a separate decision to the GGSN corresponding to the previous “Authorize QoS Resources” request.

The following figure presents the “Revoke Authorization for UMTS and IP Resources” procedure.

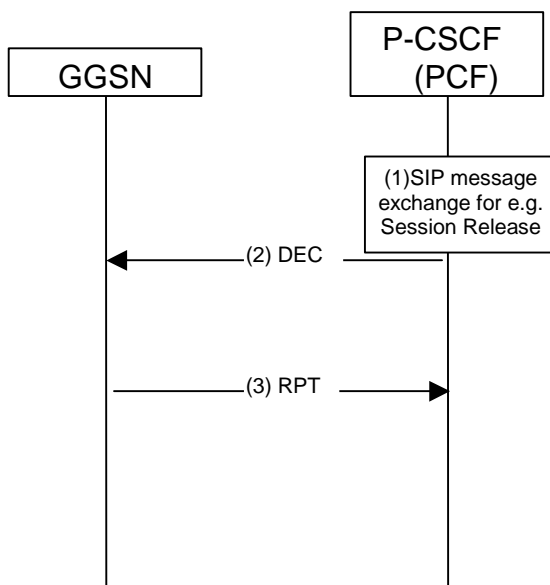

Figure B.2: Revoke Authorization for UMTS and IP resources

1. SIP message exchanges for e.g. session release are carried out.
2. The PCF shall send a COPS DEC message to the GGSN.
3. The GGSN receives the COPS DEC message, and may deactivate the PDP context used for the IP multimedia session and sends a COPS RPT message back to the PCF.

B.3 Indication of PDP Context Release

The “Indication of PDP Context Release” procedure is used upon the release of a PDP Context that was established based on authorisation from the PCF.

The following figure presents the “Indication of PDP Context Release” procedure.

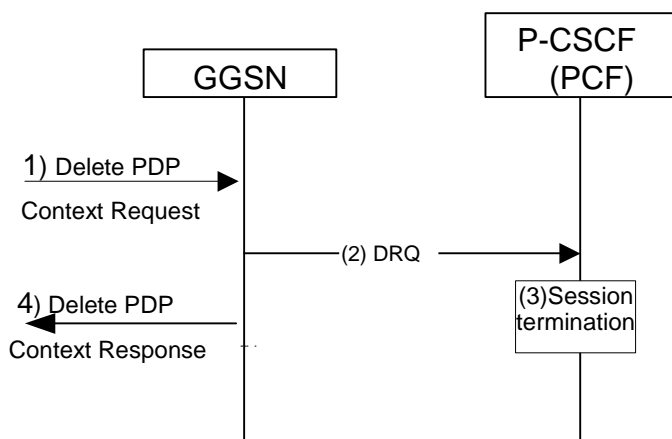

Figure B.3: Indication of PDP Context Release

1. The SGSN deactivates the PDP context related to the media flow by sending the Delete PDP Context Request message to the GGSN.

2. The GGSN sends a COPS DRQ message to the P-CSCF(PCF)
3. The P-CSCF(PCF) receives the COPS DRQ message and should initiate a session termination.
4. The GGSN sends the Delete PDP Context Response message to the SGSN to acknowledge the PDP context deletion.

Note: Step 4 may also occur at the same time or before Step 3.

Annex C (Informative): Sample Mapping of SDP Descriptions Into QoS Authorization

The QoS requirement for a session depends on the media and codec information for the session. Initial session establishment in the IM Subsystem must determine a common codec (or set of common codecs for multimedia sessions) that will be used for the session. This is done through an end-to-end message exchange to determine the complete set of common codecs, and then the session initiator makes the decision as to the initial set of codecs for the media flows.

The session initiator includes an SDP in the SIP INVITE message that lists every codec that the originator is willing to support for this session. When the message arrives at the destination endpoint, it responds with the subset that it is also willing to support for the session by selectively accept or decline those media types in the original list. When multiple media codecs are listed, the caller and called party's media fields must be aligned—that is, there must be the same number, and they must be listed in the same order. QoS authorization is performed for this common subset. The P-CSCF(PCF) shall use the SDP contained in the SIP signaling to calculate the proper authorization. The authorization shall include limits on IP resources, and restrictions on IP packet flows, and may include restrictions on IP destinations. These restrictions may take the form of a flowspec and filterspec.

The QoS authorization for a session shall include an Authorization-Token, which shall be assigned by the P-CSCF(PCF). The Authorization-Token may contain information that identifies the P-CSCF(PCF) that generated the token. Each authorized session may include several flow authorizations. Each flow authorization may contain the following information:

- IP flow 5-tuples that identifies the flow
- FLOWSPEC that describes the authorized resource for the flow
- DSCP that identifies the assigned DiffServ PHB the flow
- The IP flow 5-tuples includes Source Address, Source Port, Destination Address, Destination Port and Protocol ID. The FLOWSPEC includes the following elements:
 - Token rate [r]
 - Bucket depth [b]
 - Peak rate [p]
 - Minimum policed unit [m]
 - Maximum packet size [M]

A typical SDP description consists of a session-level description (details that apply to the whole session and all media flows) and the several media-level descriptions (details that apply to a single media flow). The four critical components for mapping an SDP description into a QoS authorization are the media announcements (“m=”), the connection data (“c=”), the attributes (“a=”) and the bandwidth (“b=”).

The media announcements field contains information about the type of media session, and is of the form:

m=<media> <port> <transport> <fmt list>

The attributes field contains attributes of the preceding media session, and is of the form:

a=<attribute><value>

The connection data field contains information about the media connection, and is of the form:

c=<network type> <address type> <connection address>

The optional bandwidth field contains information about the bandwidth required, and is of the form:

b=<modifier>:<bandwidth-value>

An example SDP description from the session originator in the SIP INVITE message:

```
v=0
o=hshieh 2890844526 2890842807 IN IP4 saturn.attws.com
s=-
c=IN IP4 192.141.10.188
t=0 0
b=AS:64
m=audio 29170 RTP/AVP 3 96 97
a=rtpmap:96 G726-32/8000
a=rtpmap:97 AMR
a=fmtp:97 mode-set=0,2,5,7; maxframes=2
m=video 51372 RTP/AVP 34
a=fmtp 34 SQCIF=2/MaxBitRate=500/SAC AP
m=application 32416 udp text_chat
```

The called party answers the call and returns the following SDP description in the SIP 183 message:

```
v=0
o=johndoe 2890844526 2890842807 IN IP4 uranus.solar.com
s=-
c=IN IP4 204.142.180.111
t=0 0
b=AS:64
m=audio 31160 RTP/AVP 3 97
a=rtpmap:97 AMR
a=fmtp:97 mode-set=0,2,5,7; maxframes=2
a=recvonly
m=video 61000 RTP/AVP 31
a=fmtp 34 SQCIF=2/MaxBitRate=500/SAC AP
m=application 33020 udp text_chat
a=sendonly
```

Upon receiving the above SDP, the originator's P-CSCF will authorize QoS resource for the originator UE with the following media flows:

A uplink audio flow:

The following IP 5-tuples identify the flow:

SrcAddress	SrcPort	DestAddress	DestPort	ProtocolID
192.141.10.188	*	204.142.180.111	31160	17

This audio flow uses either AMR or GSM FR codec and the authorized resource envelope can be expressed as a FLOWSPEC as follow:

b	m	M	r	p
72.5 bytes	52 bytes	72.5 bytes	3625 bytes/s	3625 bytes/s

*See Note 1 for the mapping calculation

Since the conversational audio is very sensitive to delay, the DiffServ EF class will be used for the flow, e.g., DSCP = 101110

A uplink video flow:

The following IP 5-tuples identify the flow:

SrcAddress	SrcPort	DestAddress	DestPort	ProtocolID
192.141.10.188	*	204.142.180.111	61000	17

The video flow uses H.263 SQCIF codec with 15frame/s. Let's assume the average bit rate and peak bit rate for the encoded video are 28kb/s and 40kb/s respectively. The authorized resource envelope can be expressed as a FLOWSPEC as follow:

b	m	M	r	p
373 bytes	273 bytes	373 bytes	4095 bytes/s	5595 bytes/s

*See Note 2 for the mapping calculation

The video flow may be assigned a DiffServ AF class with DSCP = 001010

A downlink video flow:

The following IP 5-tuples identify the flow:

SrcAddress	SrcPort	DestAddress	DestPort	ProtocolID
204.142.180.111	*	192.141.10.188	51372	17

The video flow uses H.263 SQCIF codec with 15frame/s. Let's assume the average bit rate and peak bit rate for the encoded video are 28kb/s and 40kb/s respectively. The authorized resource envelope can be expressed as a FLOWSPEC as follow:

b	m	M	r	p
---	---	---	---	---

373 bytes	273 bytes	373 bytes	4095 bytes/s	5595 bytes/s
-----------	-----------	-----------	--------------	--------------

*See Note 2 for the mapping calculation

The video flow may be assigned a DiffServ AF class with DSCP = 001010

A downlink udp flow:

The following IP 5-tuples identify the flow:

SrcAddress	SrcPort	DestAddress	DestPort	ProtocolID
204.142.180.111	*	192.141.10.188	32416	17

Assuming a typing speed of 1 char to 50 chars a second, the authorized resource envelope may be expressed as a FLOWSPEC as follow:

b	m	M	r	p
90 bytes	41 bytes	90 bytes	41 bytes/s	90 bytes/s

*See Note 3 for the mapping calculation

The udp application flow may be assigned a DiffServ AF class with DSCP = 010100

Note 1: With AMR or GSM FR codec, the authorization shall use the maximum rate of the two, i.e., 13kb/s. With 20ms frames, there are 50 frames per second and each frame has 260 bits or 32.5 bytes payload. With IP/UDP/RTP overhead of 40 bytes, each packet is 72.5 bytes. The token rate and peak rate for the session (i.e., r and p) are $72.5 \times 50 = 3625$ bytes /s. The bucket depth and Maximum packet size (i.e., b and M) are 72.5 bytes. The minimum AMR rate of 4.75kb/s is used to calculate the minimum policed unit m. At that rate, each frame has 95 bits or 16 bytes. With the overhead of 40 bytes, we have m equals to 52 bytes.

Note 2: With variable video codec h.263, we assume an average rate at 28kb/s and peak rate at 40kb/s. The average rate is used to calculate r and m. With 15 frames a second, each frame has 1867 bits or 233 bytes. Each packet is 273 bytes, so the r is $273 \times 15 = 4095$ bytes/s and the m is 273 bytes. The peak rate is used to calculate b, M and p. With 40kb/s and 15 frames/s, each frame has 2667 bits or 333 bytes. Each packet is 373 bytes, so the p is $373 \times 15 = 5595$ bytes/s and the b and M are 373 bytes.

Note 3: The calculation is the same as in Note 2 with average rate of 1 byte/s and peak rate of 50 bytes/s.

[Editorial note: The sample mappings in this section are for illustration purpose only. The actual mapping of media codec to QoS resource requirement, e.g., FLOWSPEC, is for further study.]

Annex D (Informative): Change History

Change history				
Date	TSG #	TSG Doc.	Rev	Subject/Comment
2000-10		23.XXX	0.0.0	Initial version of the specification presented at S2 QoS Drafting Meeting in Sophia Antipolis
2000-10		23.207	0.0.1	Revision with comments from the S2 QoS Drafting Meeting in Sophia Antipolis. Updates to TS title, scope. TS number included.
2000-11	S2#15	23.207	0.0.2	This version is not approved.
2000-11	S2#15	23.207	0.0.3	Annex C (IP BS Manager Functionality in the GGSN) is added. S2 QoS Group-approved editorial updates are incorporated which have been raised before and during the QoS Drafting Meeting at Makuhari, Japan.
2000-11	S2#15	23.207	0.1.0	This version incorporates all agreements that were made during QoS Drafting Meeting/S2#15 at Makuhari, Japan. Major changes are the following: Subsections 5.1.1.2 (Interactions to External Networks), C.1 (Policy Enforcement Point in GGSN), C.2 (Policy Control Interface), C.2.1 (Additional COPS Objects Needed for Policy Control), and Annex D (Mechanisms for Interaction with External Networks) are added. Text related to working assumption on interaction of bearer service with policy control is added to Annex C. Text related to application on the external device is added to Subsection 4.1
2000-11	S2#15	23.207	1.0.0	Content is the same as V0.1.0 (change marks have been cleaned). This version is submitted to SA#10 for information.
2001-01	S2#16	23.207	1.0.1	Editorial revision of V1.0.0. Editorial notes regarding 'APN outside the GGSN' are removed.
2001-01	S2#16	23.207	1.1.0	This version incorporates all agreements that were made during the QoS Drafting Meeting/S2#16 at Los Angeles, USA. Major changes are the following: Old Annex C (IP BS Manager Functionality in the GGSN) is deleted. Subsections 5.1.1.2 (IP BS Manager Functionality in the GGSN), and new Annex C (Call Flow: QoS Interaction Procedure) are added.
2001-02	S2#17	23.207	1.2.0	This version incorporates all agreements that were made resulting from email approvals of contributions from S2#16. Major changes are the following: The S2 working assumptions regarding the location of the PCF and the interface between the P-CSCF (PCF) and GGSN are added to Subsection 5.1.1.1 (QoS management functions for end-to-end IP QoS in UMTS Network). Text on the pull model is added to Subsection 5.1.1.2.2 (Policy Control Interface). Subsection 5.1.1.2.3 (Bearer Level / Application Level Binding Mechanism) is added. Subsections A.2.5 (Scenario 5), A.2.6 (Scenario 6), and A.3.2 (RSVP in Scenario 6) are modified to show authorization token aspects.
2001-03	S2#17	23.207	1.3.0	This version incorporates all agreements that were made during the QoS Drafting Meeting/S2#17 at Göteborg, Sweden. Major changes are the following: Cleanup of IP Policy Architecture Description in Section 5.1 (QoS Management Functions in the Network). Clarification on the Policy Control Interface in Subsection 5.1.1.2.2 (Policy Control Interface). Text added to Subsection 5.1.1.2.3 (Bearer Level / Application Level Binding Mechanism) on Binding Information in PDP context activation/modification. Clarification of RSVP Proxy Function in GGSN in Subsection A.2.6 (Scenario 6). Addition of new informative Annex D (Sample Mapping of SDP Descriptions Into QoS Authorization).
2001-05	S2#18	23.207	1.4.0	This version incorporates all agreements that were made resulting from email approvals of contributions from S2#17. Major changes are the following: The aspect of SIP/SDP interworking for QoS is added to the 6 scenarios in Annex A.
2001-05	S2#18	23.207	1.4.1	This version is not approved.
2001-05	S2#18	23.207	1.4.2	This version incorporates the results of the S2 QoS Restructure Drafting Meeting (S2 QoS Drafting Antwerp). The changes are the following: Incorporation of agreed TS restructure outline into the document.

2001-05	S2#18	23.207	1.5.0	This version incorporates agreements that were made during the QoS Drafting Meeting at Antwerpen, Belgium. Major changes are the following: Creation of Subsection 3.1 (Definitions). Inclusion of text in Subsection 5.2 (Capabilities of Functional Elements). Deletion of Subsection 5.1.1.2.1 (Policy Enforcement Point in the GGSN).
2001-05	S2#18	23.207	1.6.0	This version is not approved.
2001-05	S2#18	23.207	1.7.0	This version incorporates all agreements that were made during S2#18.
2001-05	S2#18	23.207	1.7.1	This version incorporates email approved editorial corrections involving the proper inclusion of all agreements made in Puerto Rico by the Editor to Version 1.7.0.
2001-05	S2#18	23.207	1.7.2	This version incorporates an overall editorial cleanup proposed by the Editor.
2001-06	S2#18	23.207	1.7.3	This version incorporates email approved corrections involving the overall editorial cleanup proposed by the Editor in Version 1.7.2.
2001-06	S2#18	23.207	2.0.0	Content is the same as Version 1.7.3 (change marks have been cleaned). This version is submitted to SA#12 for approval as Version 5.0.0.

Editor: Johnson Oyama (Johnson.Oyama@era.ericsson.se)
