

Source: TSG SA WG2
Title: Cover page for 23.226 version 2.0.0
Agenda Item: 7.2.3

This is a revision of the Stage 2 specification for Global Text telephony (GTT) with proposed modifications for the location of the CTM/Text telephony interworking function. It gives an overview of the architecture aspects of introduction of text conversation in 3GPP networks.

This is a merge of the three solutions; CTM Service Node, CTM circuit pool and All transcoders.

Note that this TS was not presented in version 1.0.0 : it was less than 50 % stable at SA#11 but SA2 now judges the TS is 80% stable and then asks TSG SA to approve to raise it to version 5.0.0.

3G TS 23.226 V2.0.0 (2001-06)

Technical Specification



3rd Generation Partnership Project; Technical Specification Group Services and System Aspects Global Text Telephony (GTT); Stage 2 (3G TS 23.226 version 2.0.0)

The present document has been developed within the 3rd Generation Partnership Project (3GPP™) and may be further elaborated for the purposes of 3GPP. The present document has not been subject to any approval process by the 3GPP Organisational Partners and shall not be implemented. This Specification is provided for future development work within 3GPP only. The Organisational Partners accept no liability for any use of this Specification. Specifications and reports for implementation of the 3GPP™ system should be obtained via the 3GPP Organisational Partners' Publications Offices.

Reference

DTS/TSGSA-0223226

Keywords

Text Telephony, Conversation, Multi Media,
Total Conversation

3GPP

Postal address

3GPP support office address

650 Route des Lucioles - Sophia Antipolis
Valbonne - FRANCE
Tel.: +33 4 92 94 42 00 Fax: +33 4 93 65 47 16

Internet

<http://www.3gpp.org>

Copyright Notification

No part may be reproduced except as authorized by written permission.
The copyright and the foregoing restriction extend to reproduction in all media.

© 1999, 3GPP Organizational Partners (ARIB, CWTS, ETSI, T1, TTA, TTC).
All rights reserved.

Contents

Foreword.....	4
Introduction	4
1 Scope	4
2 References	5
3 Definitions and abbreviations	6
3.1 Definitions.....	6
3.2 Abbreviations.....	6
4 General Functions	7
4.1 Overview.....	7
4.1.1 General text transmission functions.....	8
4.1.2 Functions	8
4.1.3 Emergency service considerations.....	10
5 Considerations for each host environment.....	10
5.1 GTT-IP IP Multimedia.....	10
5.2 GTT-CS Circuit switched Multimedia	10
5.3 GTT-Voice Circuit switched voice channel	10
5.3.1 Interworking between GTT-Voice and PSTN Text Telephony.....	10
5.3.2 Functional details of fixed network interworking.....	12
5.3.3 Emergency call considerations for GTT-Voice.....	12
5.3.4 Interworking aspects.....	13
Annex A (informative) GTT-Voice specific information for CTM support in, or associated with, all transcoders.....	13
A.1 GTT-Voice specific information for CTM support in, or associated with, all transcoders in the access network for GSM networks with A-interface	13
A.2 GTT-Voice specific information for CTM support in or associated with all transcoders in the core network for networks supporting the Iu interface.....	14
Annex B (informative) GTT-Voice support via selection of CTM detection/conversion function.....	15
B.1 GTT-Voice specific information for CTM support in GSM networks with A-interface, via access network circuit pooling.....	15
B.2 GTT-Voice specific information for CTM support via core network termination selection for networks using Iu interface	16
Annex C (Informative). GTT-Voice specific information for the CTM-SRF core network node solution.....	18
C.1 Emergency calls.....	18
C.2 Routing of regular user calls	19
C.2.1 Mobile Terminating calls.....	19
C.2.2 Mobile originating calls.....	20
C.2.3 Mobile to Mobile Calls.....	22
C.3 Routing actions of the CTM-SCP.....	22
C.4 Routing actions of the CTM-SRF.....	23
C.5 Service interactions.....	24
C.5.1 Interaction with other CAMEL services	24
C.5.2 Interactions with Supplementary Services	24
C.5.3 Emergency Call interaction.....	24
C.5.4 Usage of Destination Routing Address	25
C.5.5 Inserting CTM/Text telephone conversion function	25
C.5.6 Lawful interception.....	25

History	25
---------------	----

Foreword

This Technical Specification has been produced by the 3GPP.

The contents of the present document are subject to continuing work within the TSG and may change following formal TSG approval. Should the TSG modify the contents of this TR, it will be re-released by the TSG with an identifying change of release date and an increase in version number as follows:

Version x.y.z

where:

- x the first digit:
 - 1 presented to TSG for information;
 - 2 presented to TSG for approval;
 - 3 Indicates TSG approved document under change control.
- y the second digit is incremented for all changes of substance, i.e. technical enhancements, corrections, updates, etc.
- z the third digit is incremented when editorial only changes have been incorporated in the specification;

Introduction

Real time, character by character text conversation is a component that can be of value in a distant conversation. Users may have an interest to use real time text conversation alone or in any combination with voice and video.

Global Text Telephony is a feature that adds the capability to use a text conversation component in a session. It is called GTT here.

GTT is defined in a set of host environments, circuit switched as well as packet switched.

Interworking with corresponding features in other networks is an important part of Global Text Telephony. Specifically, the different kinds of PSTN text telephone systems supported by the international text telephone modem standard ITU-T V.18 are included in the modes for interworking consideration.

One important reason to offer the Global Text feature is to enable emergency service access to people who are depending on a written dialogue.

A more elaborated background is found in 3GPP 22.226, Global Text Telephony, Stage 1, Annex A, [3]

1 Scope

This 3GPP Technical Specification defines the stage 2 description of the real time Text Conversation Feature called Global Text Telephony, GTT. GTT. Stage 2 identifies the functional capabilities needed to support the service described in GTT Stage 1.

This TS contains the core functions for a real time Text Conversation Feature GTT, to be used in combination with other media in conversational services.

GTT offers real time conversation in text, to be used alone or in combination with other conversational media, and interworking with current and emerging text conversation features in the fixed networks and other mobile networks.

GTT uses a number of functional entities to realise the requirements of the stage 1 description (3G TS 22.226). This TS describes how the service requirements are realised with these functional entities. As far as possible existing protocols shall be used for the realisation of the Global Text Telephony Feature. This may include e.g. , SIP, 3G.324, or Circuit Switched Voice service as protocol environments, and CTM, AL1 and RTP/text as transmission protocols. It also means usage of existing text presentation format ITU-T T.140, common to all GTT text conversation environments..

2 References

The following documents contain provisions which, through reference in this text, constitute provisions of the present document.

- References are either specific (identified by date of publication, edition number, version number, etc.) or non-specific.
- For a specific reference, subsequent revisions do not apply.
- For a non-specific reference, the latest version applies.
- A non-specific reference to an ETS shall also be taken to refer to later versions published as an EN with the same number.

- [1] 3G TS 22.101: "Service Principles"
- [2] 3G TS 22.121: "The Virtual home Environment"
- [3] 3G TS 22.226: "Global Text Telephony " Stage 1 service description.
- [4] ITU-T V.18 Operational procedures for modems in the text telephone mode.
- [5] ITU-T T.140 Text conversation presentation protocol
- [6] 3GPP 26.110 Codec for 3G CS Multimedia (2000)
- [7] ITU-T H.323 Annex G, Text conversation and text SET (2000)
- [8] ITU-T H.224 (2000) Very low bitrate multimedia system
- [9] ITU-T H.248 Annex F, Facsimile, Text Conversation and Call Discrimination Packages
- [10] IETF RFC 2793 RTP-Text. RTP Payload for Text Conversation.
- [11] IETF SIP, Session Initiation Protocol
- [12] 3G TS 26.226 CTM Cellular Text telephony Modem, General description
- [13] ITU-T F.703 Multimedia Conversation Service Description (2000)
- [14] 3GPP TS 26.235 Codec for packet switched conversation
- [15] 3GPP TS 48.008 Mobile-services Switching Centre - Base Station System (MSC - BSS) interface; Layer 3 specification
- [16] 3GPP TS 24.008 Mobile radio interface layer 3 specification; Core Network Protocols - Stage 3

3 Definitions and abbreviations

3.1 Definitions

Total Conversation A service offering standardised simultaneous text, video and voice conversation or a subset thereof. (see ITU-T F.703)

Host environment The session environment where the text component is added. E.g. Circuit switched voice, IP Multimedia etc.

Text Conversation A real time conversation in text with transmission character by character as entered.

3.2 Abbreviations

For the purposes of this document the following abbreviations apply in addition to those defined in [3]:

GTT Global Text Telephony

CTM Cellular Text telephone Modem, as specified in 3Gpp 26.226 [12]

BCSM Basic Call State Model

CAMEL Customised Application for Mobile Enhanced Logic

CAP CAMEL Application Protocol

CLIP Calling Line Presentation

CPC Calling Party Category

GMSC Gateway MSC

HPLMN Home PLMN

ISUP ISDN User Part

MSC Mobile Switching Centre

MSRN Mobile Station Roaming Number

NDC National Destination Code

PLMN Public Land Mobile Network

SK Service Key

TRAU Transcoder and Rate Adaption Unit

UMTS Universal Mobile Telecommunication System

VLR Visited Location Register

4 General Functions

4.1 Overview

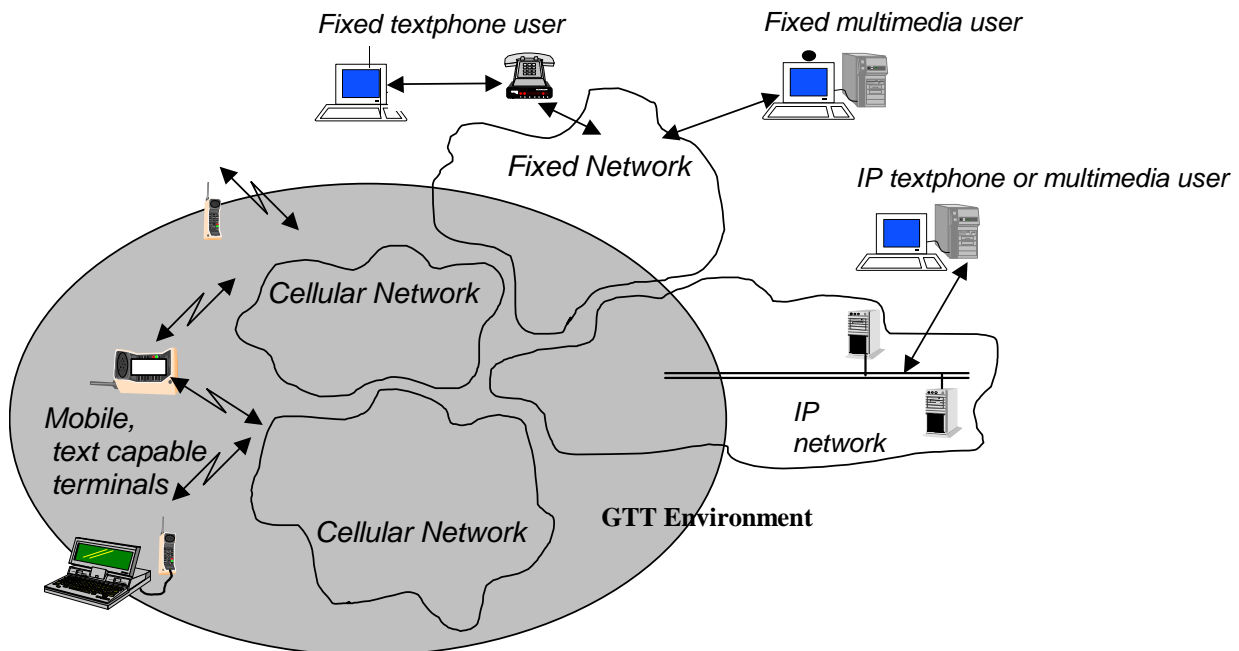

Figure 1: General view of GTT feature provision within the different networks

Figure 1 shows a generalised view of the Global Text Telephony feature architecture for a third generation conversation service system. It shall combine different networks and network types and shall integrate text conversation systems already existent within these networks.

Global Text Telephony is a 3GPP Feature that can be included in 3GPP conversation services such as circuit switched voice telephony, circuit switched multimedia and IP multimedia conversation. It makes use of the infrastructure of the host environment and includes elements necessary for GTT in these environments.

The following description and figures describe the text specific parts and leave out many details of the host environment conversation service where text is included.

4.1.1 General text transmission functions

On the route from user to user, the text passes a set of functional elements.

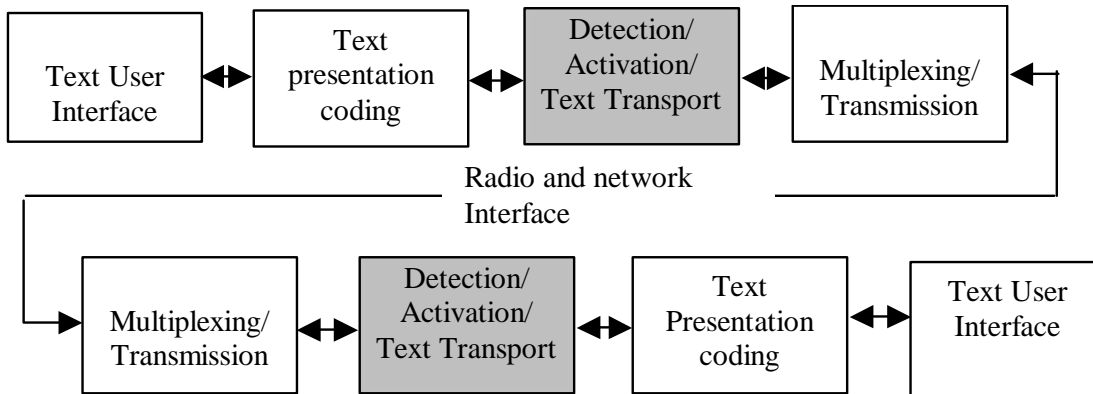

Figure 2, call flow for two mobile terminals with the same GTT transport method, using text conversation.

Figure 2 shows the function chain when communicating within the network, between terminals operating in the same mode.

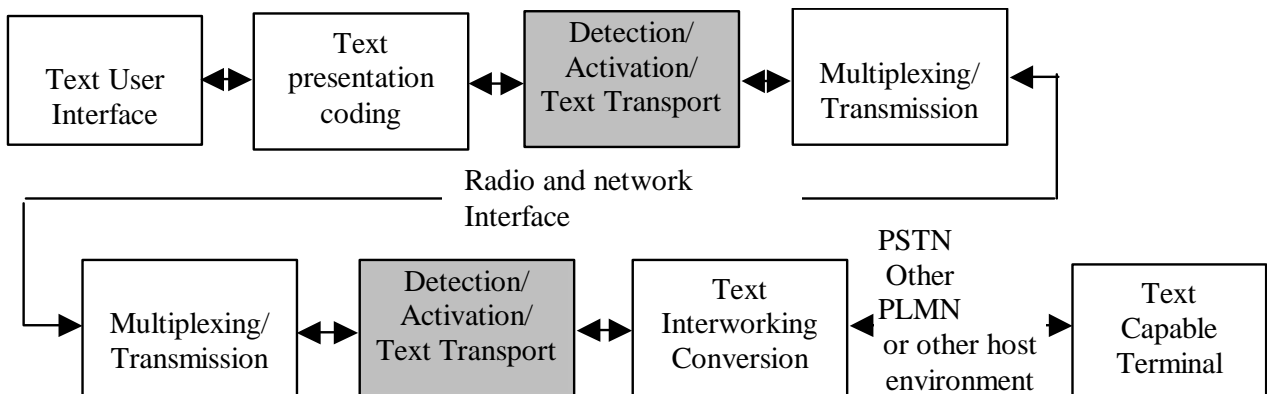

Figure 3 : GTT general text transmission functions showing interworking

The view in figure 3 is applicable to transport mechanisms and network environments when communicating in interworking mode between different environments.

4.1.2 Functions

4.1.2.1 Call Control and text media initiation

Before text conversation can begin, a call must be established. That is done with general call control functions of the host environment. GTT Elements detect the desire to establish a text channel, select a suitable transport mechanism, and activate transmission functions.

4.1.2.2 Presentation coding

The text in GTT shall be coded in a common presentation protocol, T.140 [7]. If necessary this presentation protocol shall be converted to or from any legacy mode character code used in other networks.

4.1.2.3 Transport and transmission host environments

When text transmission is activated, a suitable transmission method in the PLMN is selected. The appropriate method to use is selected according to the call environment. The environments valid for GTT are called GTT Host environments.:

1. IP Multimedia, according to IPMM subsystem with IETF SIP [11].
2. Circuit Switched Multimedia according to 3G.324.
3. Circuit switched voice channel.

Other methods to establish real time text conversation exist and may be used without further standardisation, using basic communication services of the PLMN. One example:

Digital data transmission in a data channel can be used for real time text conversation. For cases when only text conversation is wanted, there are a multitude of ways to implement that kind of communication. It can for example be done through a HTML based server, with an already established mainstream mechanisms that do not require text conversation specific functions to be stored in the terminals. An alternative may be to use GSM circuit switched data functions for text telephones that are compatible with the modem characteristics provided.

4.1.2.4 Multiplexing

The text transport is multiplexed in the network and radio interface according to normal procedures for the selected host environment.

4.1.2.5 Conversion.

For text conversation with text telephones and text capable terminals in different networks or using different transport mechanisms, conversion functions may be used. Functions and procedures suitable for the conversion functions are described in ITU-T H.248 Annex F, packages for Text telephony, Text Conversation and Call Type Discrimination [6].

4.1.2.6 Text capable terminal

By using the described GTT functions, a real time text conversation session can be conducted between GTT supported mobile Text Capable Terminals.. Different terminal function combinations and GTT host environments give different opportunities regarding combinations of text with voice and video. Valid combinations are:

text only,
alternating text and voice,
simultaneous text and voice,
simultaneous text and video,
simultaneous text, video and voice.

4.1.2.7 Routing and location of CTM detection/conversion functions

There are three ways to include conversion functions between legacy text telephony and CTM.

- The “All transcoder solution”.
The CTM detection/conversion can be carried out within the transcoder function or within a separate node associated with the transcoder function. This approach means that no specific routing is required since the CTM detection/conversion function will be present in every speech call. Further explanations are found in Annex A.
- The “CTM circuit pool solution”.
The CTM detection/conversion function can be located in a dedicated resource pool in the access network or can be associated with transcoders in the core network. In these cases, the MSC/MSC Server requires an indication from the terminal that this CTM detection/conversion function is required. See 3GPP TS 24.008 [16] for the definition of this indication. This indication provides the necessary information to invoke the CTM detection/conversion function. 3GPP TS 48.008 [15] defines mechanisms for pool identities and selection. Further explanations are found in Annex B.

- The “CTM-SRF core network node solution”.
The CTM detection/conversion function can be placed in the core network as a separate CTM Special Resource Function (CTM-SRF), in which case routing functions are required to make sure calls are routed via the CTM-SRF for CTM detection/conversion. Routing can for example be based on subscriber data or specific call conditions available for MSC routing, e.g. emergency calls. Further explanations are found in Annex C.

4.1.3 Emergency service considerations

If an operator implementing GTT selects to offer access to Emergency Services through this feature for a specific host environment, the following must be considered.

If the emergency services only has limited types of text conversation devices, conversion from the users host environment to the one used by the emergency service may be configured.

If the calling party address and location information are provided in voice emergency calls, this information must be preserved also in text emergency calls, and not changed by any conversion or routing mechanisms introduced.

Other host environment specific considerations for emergency calls are described in sections below.

5 Considerations for each host environment

5.1 GTT-IP IP Multimedia

IP Multimedia, supported by the IPMM subsystem, is a suitable environment for real time text conversation. It shall use IETF SIP [11], with text coded according to ITU-T T.140 and transported with IETF RTP-text [10] as indicated in 3G TS 26.235 [14]. This allows conversation in a selection of simultaneous media, such as text, video and voice.

Inclusion of the text conversation shall be done according to normal SIP and IPMM procedures, where the text media stream is handled as any other media. GTT-IP has no architecture influence on the 3G network, only that the components must allow handling of the standardised text media stream.

Note: This way of using mainstream procedures opens possibilities to utilize the flexibility of the SIP protocol for enhanced services. The user can interact in the service offering to optimise the stream handling. This may be used for flexible ways of invoking relay services for media conversion according to the desire of the users.

5.2 GTT-CS Circuit switched Multimedia

Text conversation in Circuit Switched Multimedia is called GTT-CS. The host environment is 3G.324, according to 3GPP TS 26.110. Codec for circuit switched multimedia [6]. GTT-CS Text is T.140 coded and transported in an AL1 channel. Any combination of Video, Text and Voice can be supported and used simultaneously.

GTT-CS has no architecture implications on the 3G network, only that the network components must allow the standardised handling of the text media channel as well as any other media channel.

5.3 GTT-Voice Circuit switched voice channel

Voice channel transmission of text shall use CTM; Cellular Text telephone Modem [12]. It is possible to alternate between text and voice. Text shall be coded according to ITU-T T.140 on the presentation level.

5.3.1 Interworking between GTT-Voice and PSTN Text Telephony

If GTT-Voice is provided, interworking to PSTN text telephony can be provided by introducing conversion in the PLMN between CTM and PSTN based text telephony using ITU-T V.18 or any of its specific sub-modes.

A simple extension can be made of the conversion functionality described in H.248 annex F. CTM is included among the transport mechanisms by an extension of package txc.

For the CTM and PSTN text telephone case, a conversion function can be seen as a context containing a CTM termination and a V.18 text telephony termination. This combination is called the CTM channel. It is foreseen that the CTM channel need control to be initiated to the proper state for each call etc. Such functions are here collected in an entity called interworking control.

. The CTM channels are normally transparent but monitoring for text telephone signals or CTM signals. When a signal is discovered, the audio path is stopped and character conversion and transmission performed.

It can be symbolically documented as follows.

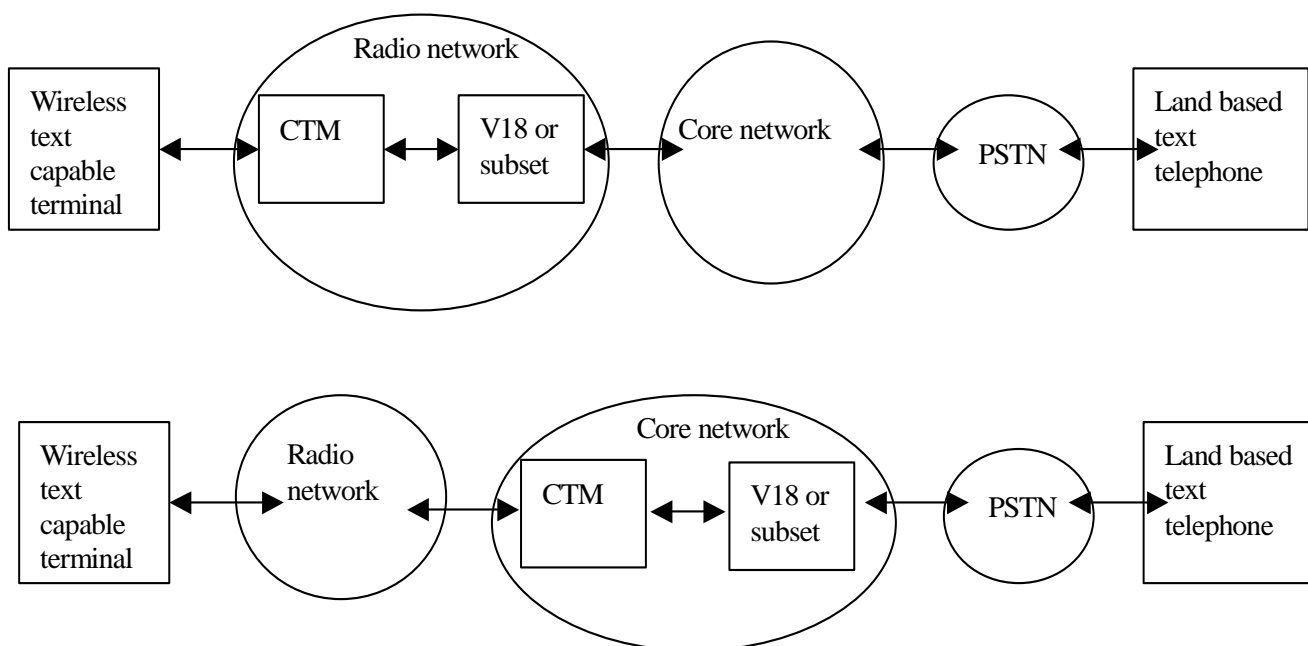

Figure 4. Interworking with PSTN

Since the PSTN text telephone protocols have states, resetting the state during the call should be avoided because it can cause loss or corruption of characters, loss of communication or a long V.18 handshake before reestablishment.

For the CTM-SRF core network node solution, already standardised routing and invocation mechanisms should be used to invoke CTM detection/conversion in the calls that may require text conversation.

The mechanisms for invocation of the CTM channel act on both Mobile Originating calls and Mobile Terminated calls.

5.3.2 Functional details of fixed network interworking

The default action of the call path in the CTM-detection/conversion function is to transfer audio transparently while monitoring for text telephone signals. When valid text telephone signals are detected, the converting action of the channel takes effect. The path converts between the detected PSTN text telephone method and CTM. This mode of operation continues until text signaling ceases. Then transparent audio transport is re-established, again monitoring for text signals. This way of action allows alternating use of text and voice during the call according to established conventions in text telephony.

3GPP TS 26.226 describes the details of CTM and an indication of how CTM can be combined with a text telephone modem to compose a conversion function in the call path.

ITU-T H.248 Annex F describes the principles of conversion between PSTN Text telephony as in the text telephone Recommendation V.18 and any general real time text conversation feature. So, even if CTM is not mentioned in that Recommendation, its general descriptions are valid for this case. On the PSTN end it is valid also for specific sub-modes of V.18 (Including the US method Baudot 45). The handling is slightly different depending on if the selected V.18 sub-mode is carrier-based or carrier-less, and if the call is known to be with a textphone or being general.

The descriptions in H.248 Annex F can be taken as functional descriptions of the call path without full implementation in a H.248 environment.

5.3.3 Emergency call considerations for GTT-Voice.

It may be required to let a user use any CTM capable mobile terminal for a text call to the emergency service. If a terminal can support CTM and establishes a call with the CTM active then it will be expected to provide the network

with an indication that a CTM detection/conversion function is required in the network.

It may be required to handle emergency calls also when the call comes from a SIM-less phone or a phone with an invalid subscription. To meet this requirement, one configuration option, when the CTM-SRF is used, shall be to route emergency calls independent of subscription status through the CTM detection/conversion function.

If the terminal supports CTM and is SIM-less, then it will be expected to indicate to the core network that CTM detection/conversion is required in the network.

Call back from emergency services is handled as normal Mobile Terminating calls.

5.3.4 Interworking aspects

The following are known interworking issues between the different circuit switched voice solutions, and these should be considered carefully before deploying different approaches within one PLMN or regulatory area:

- It is critical that all mobile terminals requiring CTM detection/conversion indicate to the network when CTM is required, otherwise a network that has adopted the CTM circuit pooling solution will not be able to allocate the appropriate CTM capable circuit. This CTM indication should therefore be considered a mandatory terminal requirement.
- An indication from a mobile terminal that CTM detection/conversion is required will not result in any interworking issues if the indication is received by a network where all the transcoders are CTM capable or where a core network CTM-SRF solution has been chosen. This is because the indication is redundant in this case.
- If a subscriber, from a network where all the transcoders are CTM capable or a CTM circuit pooling solution has been adopted, roams to a network where a core network CTM-SRF solution has been chosen, then the subscriber will only receive CTM conversion for emergency calls. The reason is that the subscriber lacks the necessary subscription to a CAMEL service, which would route this normal call via a core network CTM-SRF.
- In the case where inter-MSC handover occurs between an MSC where all the transcoders are CTM capable or a CTM circuit pooling approach is in operation, and an MSC which relies on a core network CTM-SRF, then the subscriber will lose CTM conversion for all calls.
- If a subscriber from a network where a core network CTM-SRF solution has been adopted roams to a network where all the transcoders are CTM capable or a CTM circuit pooling solution has been chosen, then the subscriber will receive CTM conversion for all calls. The presence of two CTM detection/conversion functions in tandem should not create any interworking issues.

Annex A (informative) GTT-Voice specific information for CTM support in, or associated with, all transcoders

A.1 GTT-Voice specific information for CTM support in, or associated with, all transcoders in the access network for GSM networks with A-interface

The CTM detection/conversion function may be incorporated in all transcoders where CTM activity can realistically be expected. It is also an option to incorporate a CTM detection/conversion function in a separate entity associated with the Transcoder.

The CTM adapter automatically detects the presence of CTM encoding and provides the necessary conversion to the

appropriate V.18 modem encoding.

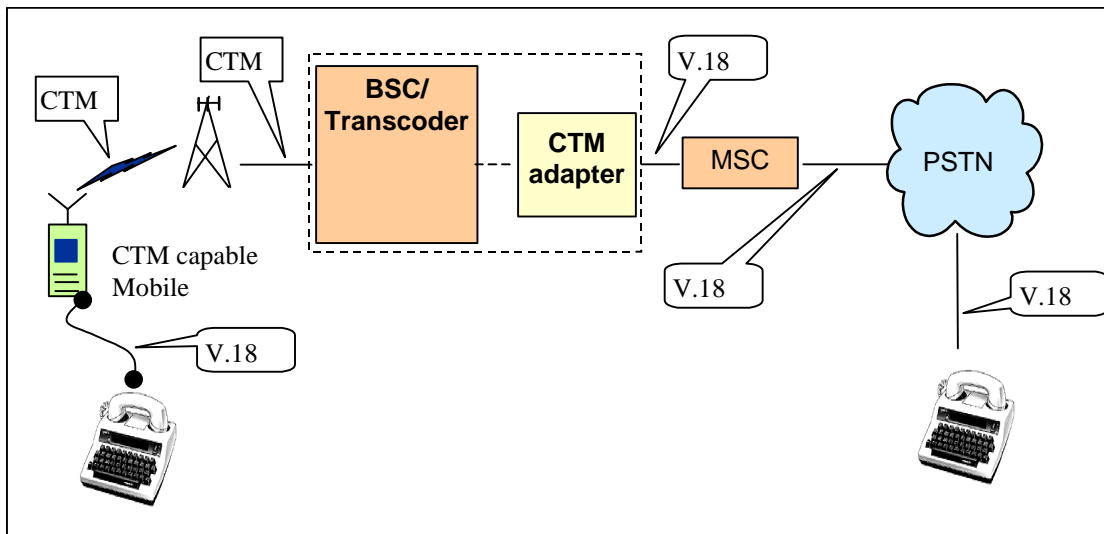

Figure A.1: Association of a CTM adapter with the transcoder in the access network

Due to the presence of the CTM detection/conversion function in all circuits, no CTM capability information needs to be signalled to the network by the mobile.

A.2 GTT-Voice specific information for CTM support in or associated with all transcoders in the core network for networks supporting the Iu interface

For networks with GERAN and UTRAN radio access using the Iu interface, the CTM detection/conversion function may be incorporated in all transcoders where CTM activity can realistically be expected. It is also an option to incorporate a CTM detection/conversion function in separate entity associated with the Transcoder.

The CTM adapter automatically detects the presence of CTM encoding and provides the necessary conversion to the appropriate V.18 modem encoding.

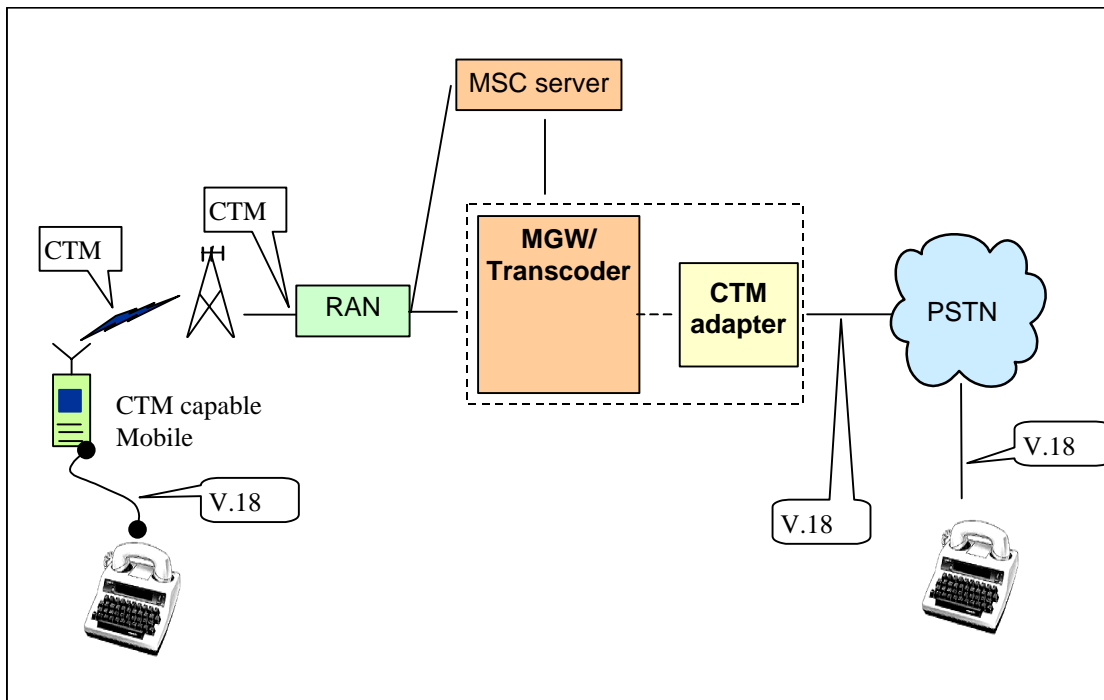

Figure A.2: Association of a CTM adapter with the transcoder in the core network

Due to the presence of the CTM detection/conversion function in all circuits, no CTM capability information needs to be signalled to the network by the mobile.

Annex B (informative) GTT-Voice support via selection of CTM detection/conversion function

B.1 GTT-Voice specific information for CTM support in GSM networks with A-interface, via access network circuit pooling

A-interface pooling, and routing to a selected pool, is an intrinsic capability within current GSM Networks and is used to select transcoding for EFR, FR and in future AMR. It is an option to create circuit pools on the A-interface, which support the CTM detection/conversion. The circuit pools are defined in 3GPP TS 48.008[15]. These pools may be incorporated in the transcoder, in a separate entity associated with a transcoder or in a separate entity located in particular A-interface circuits but remote from the transcoder.

The main steps of the process for a mobile originated call are:

- Setup from terminal, including CTM indication
- MSC detects CTM indication and allocates a circuit with CTM capabilities.

The main steps of the process for a mobile terminated call are:

- Setup from MSC.
- Call Confirm from terminal including CTM indication.

- MSC detects CTM indication and allocates a circuit with CTM capabilities.

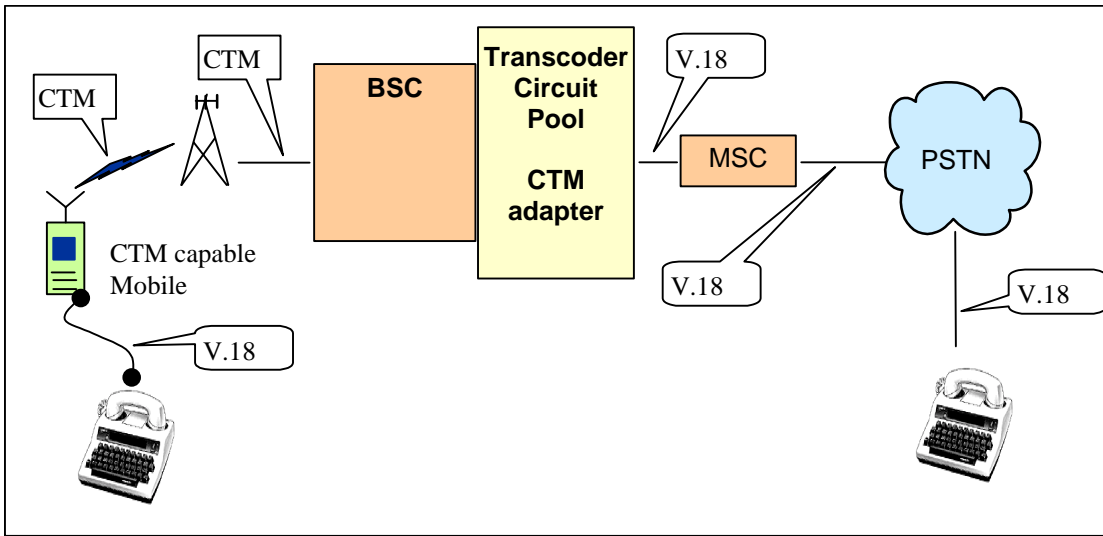

Figure B.1: CTM adaptor contained within a transcoder pool

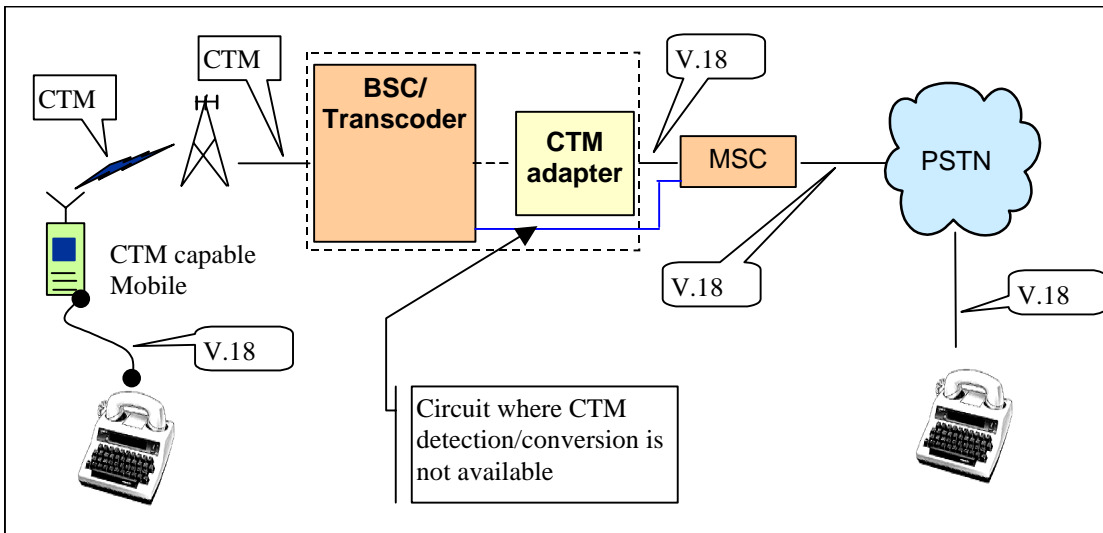

Figure B.2: CTM adaptor present on specific A-interface circuits

B.2 GTT-Voice specific information for CTM support via core network termination selection for networks using Iu interface

For networks with GERAN and UTRAN radio access using the Iu interface, a method to allocate the calls to terminations capable of handling CTM on audio channels can be provided in the core network. It can be based on the mechanisms for controlling Media Gateway functions through the control language specified on the Mc interface. The MSC Server has information on CTM indication issued by the mobile station and allocates terminations with proper CTM capabilities for the detection/conversion during the call.

The main steps of the process for a mobile originated call are:

- Setup from terminal, including CTM indication
- MSC server detects CTM indication and allocates a termination with CTM capabilities in the Media Gateway.

The main steps of the process for a mobile terminated call are:

- Setup from the MSC Server.
- Call Confirm from the terminal including CTM indication.
- The MSC server detects CTM indication and allocates a termination with CTM capabilities in the Media Gateway.

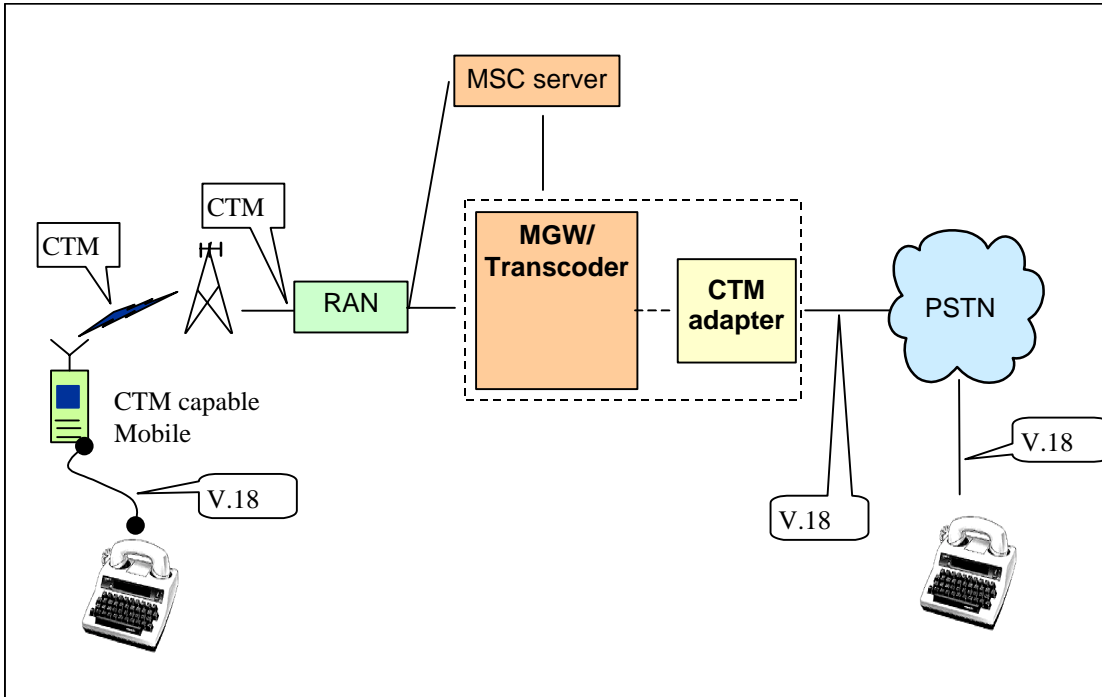

Figure B.2: Association of a CTM capable termination within the Media Gateway.

Annex C (Informative). GTT-Voice specific information for the CTM-SRF core network node solution.

This section describes a method how to route possible text calls via a core network node called the CTM-SRF. It should be taken as an informative example. It is based on CAMEL Phase 1 and call signaling with ISUP. Other call control environments and other IN service platforms can accomplish the same result.

This section shows how emergency calls, terminating calls and originating calls can be routed through the CTM-SRF node without any modification to existing core network nodes. This covers also mobile-to-mobile calls.

For cases where emergency call support for text calls is wanted, all emergency calls are routed to the CTM-SRF server. The CTM-SRF server routes the call to the emergency centre. This can be done, as the CTM/textphone conversion channel itself is transparent to speech.

Originating and terminating calls, from and to possible text telephone users, are handled as CAMEL calls. A CAMEL service assures that the calls are routed through the CTM-SRF node by actions of a CAMEL application.

C.1 Emergency calls

The network has no means to distinguish text emergency calls from voice emergency calls in areas where the same number is used for both types. It may also be desired that even a phone borrowed for the purpose of making a text emergency call shall get the text service without any specific text subscription. Therefore, in order to meet these requirements, it shall be possible to configure the network to route all emergency calls through CTM-SRF server nodes.

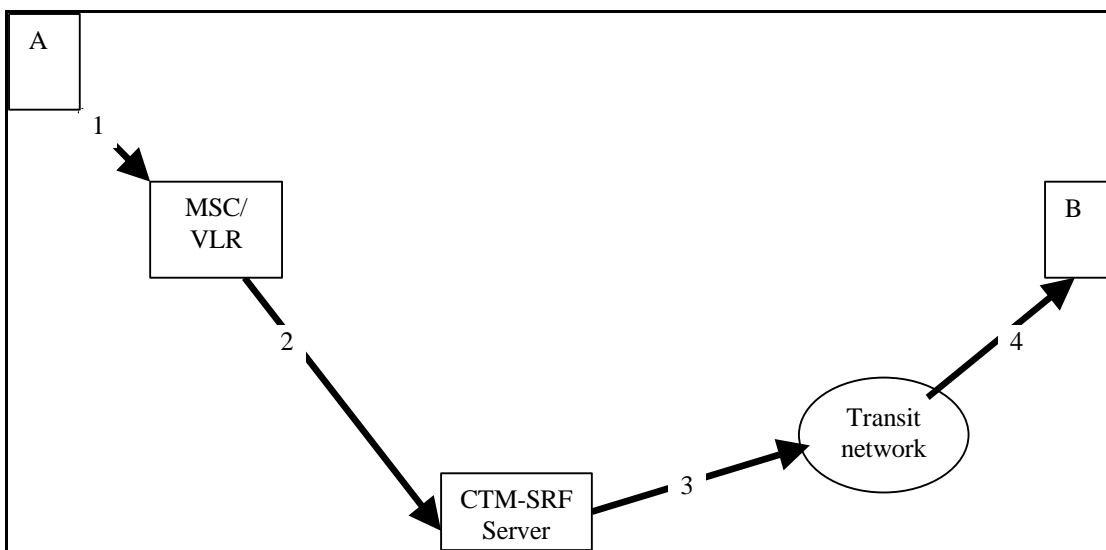

Figure C.1 Emergency call routing

If the emergency service use the same number for emergency text calls as for emergency voice calls, routing of all calls, regardless of text or speech, to a CTM-SRF server can be accomplished by configuration in the MSC/VLRs. The MSC/VLR can be configured in a way that, depending on the Emergency Centre addresses, emergency calls are always routed via a CTM-SRF server.

The CTM-SRF links in the CTM/textphone conversion function and routes the call further according to the received IAM.

The CTM-SRF node could recognise emergency calls by knowing all numbers of the emergency centres in question.

For US E-911-calls an additional method is given by looking at the CPC field. A special value is given.

- CPC "H'E0" represents "emergency service call"

In general, the CTM-SRF server handles emergency calls in the same way as normal Mobile originated calls.

C.2 Routing of regular user calls

Regular user calls that may contain text are routed to the CTM-SRF by a CAMEL service.

Text users are identified by a Text Telephony CAMEL Service Key (SK) and other CAMEL information stored in the HLR. The CTM part of this service modifies the Called Party Address (see following chapters). The call is routed through the CTM-SRF server and is then routed to the original destination.

C.2.1 Mobile Terminating calls

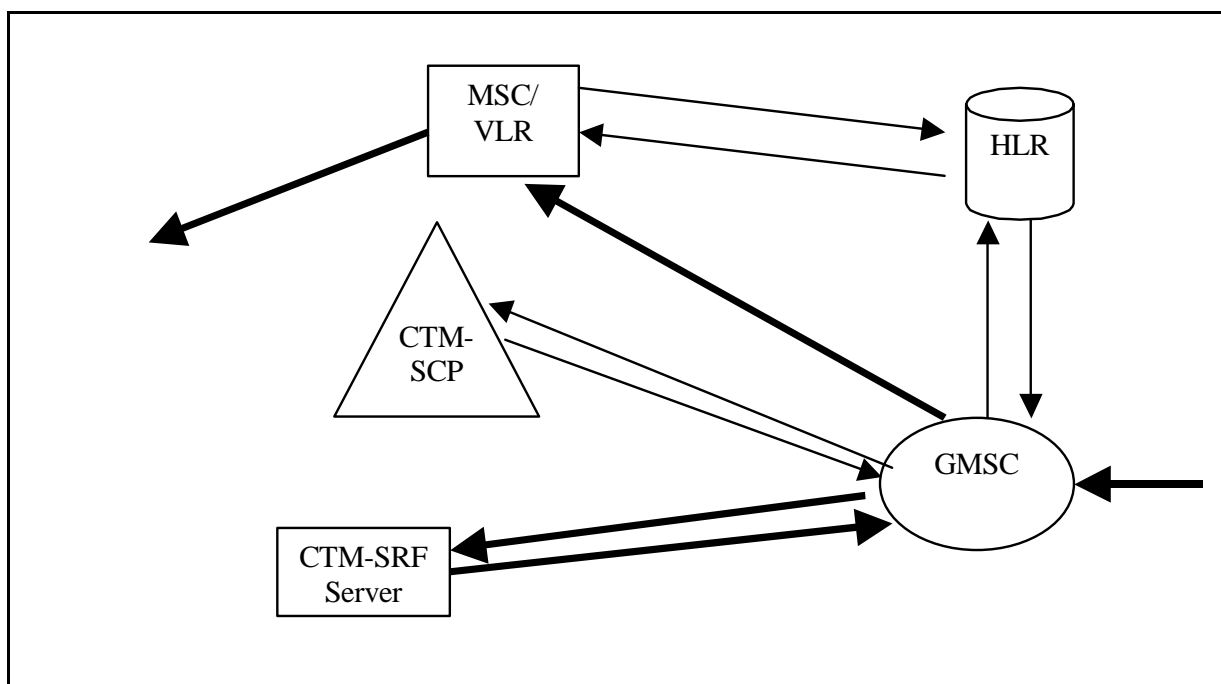

Figure C.2 Paths for routing of mobile terminating text calls with call path shown in thick arrows

The GMSC discovers that the user is a subscriber of the text telephony service, by the Camel Subscription Information information received from the HLR. The text Service Key is present and the Detection Point = Terminating_Attempt_Authorized.

The SCP with the text telephony service application is connected and the routing of the call through the CTM-SRF node is performed.

To control the activation of CAMEL service invocations an indication is sent from the CAMEL service via the CTM-SRF server back to the CAMEL service. This information is used by the CAMEL CTM-SCP service (2nd invocation) to do nothing but just to continue the call.

The indication is carried in the Calling Party Category parameter of ISUP.

This ISUP parameter is supported in CAP V1. InitialDP, and Connect. The CTM-SRF node and the CAMEL CTM-SCP service form an integrated application, and this ISUP parameter handling is regarded internal application signaling.

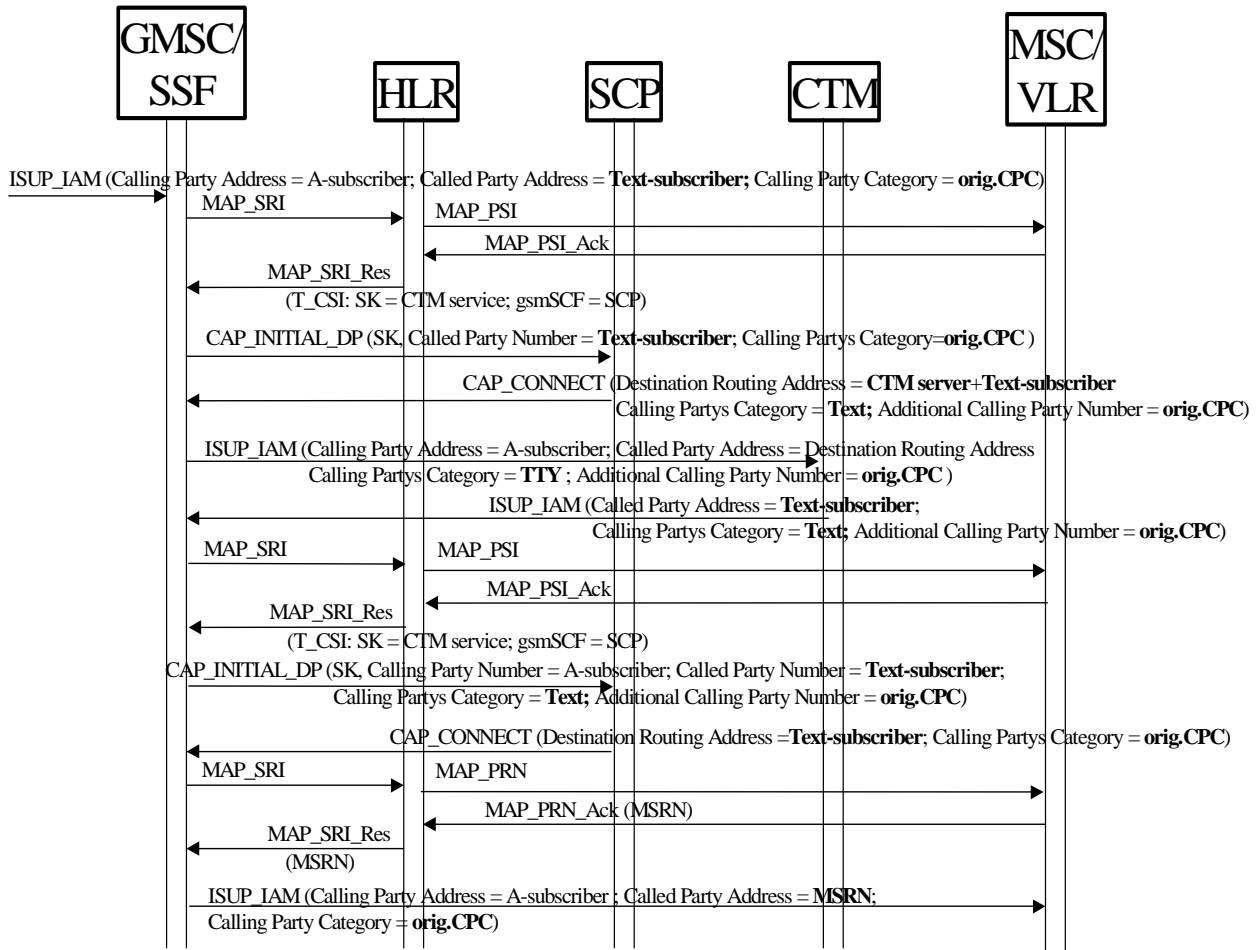

Figure C.3 Mobile Terminating Text Call

For the support of text users, the CAMEL CTM-SCP service will return the textphone-number with a CTM-SRF server prefix in CAP_CONNECT. The GMSC creates a new O-BCSM for this CAMEL based forwarding leg. It uses the Destination Routing Address in CAP_CONNECT to do the routing and to send the ISUP_IAM. The routing is based on the CTM-SRF server prefix part.

The CTM-SRF server links in the CTM/textphone conversion function and extracts Text subscriber address, Nature of Address, and the Numbering Plan Indicator from the Destination Routing Address parameter. It stores the original CPC value in Additional Calling Party Number parameter. If Called Party's Category is not received, then this information as such is encoded. It writes this information to the appropriate IAM parameters and routes the call to a GMSC. It could be the same GMSC as before or a different one.

The GMSC regards this incoming IAM as a new terminating call to a text subscriber. A second time a dialogue for the "same text call" to a CAMEL service is invoked. The service realises this fact and does nothing but connecting the call to the Text subscriber (Called Party Number, respectively Destination Routing Address has not been changed by the CTM-SRF server).

C.2.2 Mobile originating calls

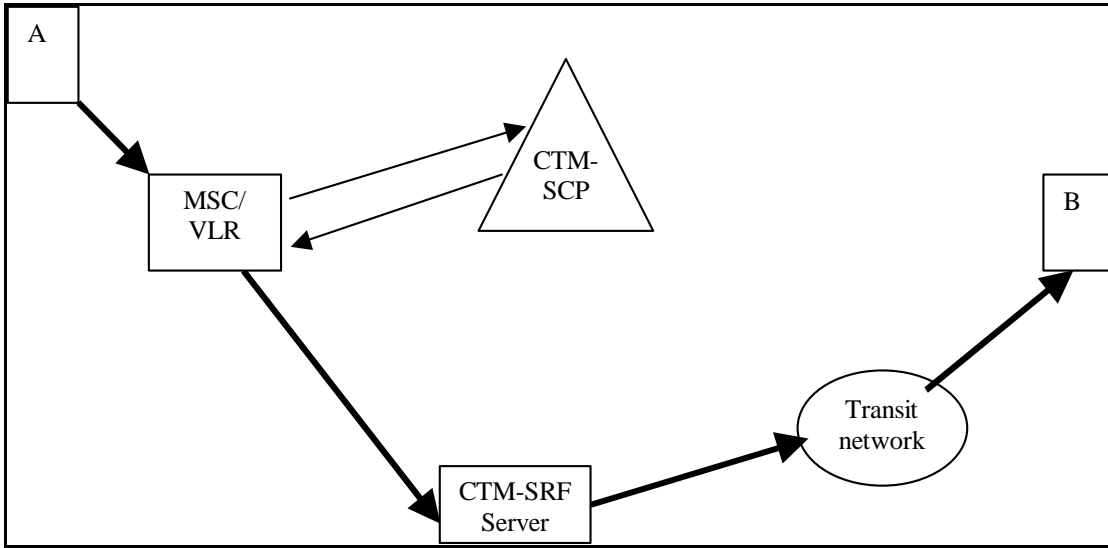

Figure C.4 Mobile originating call routing overview

The following sequence chart shows the mobile originating traffic case.

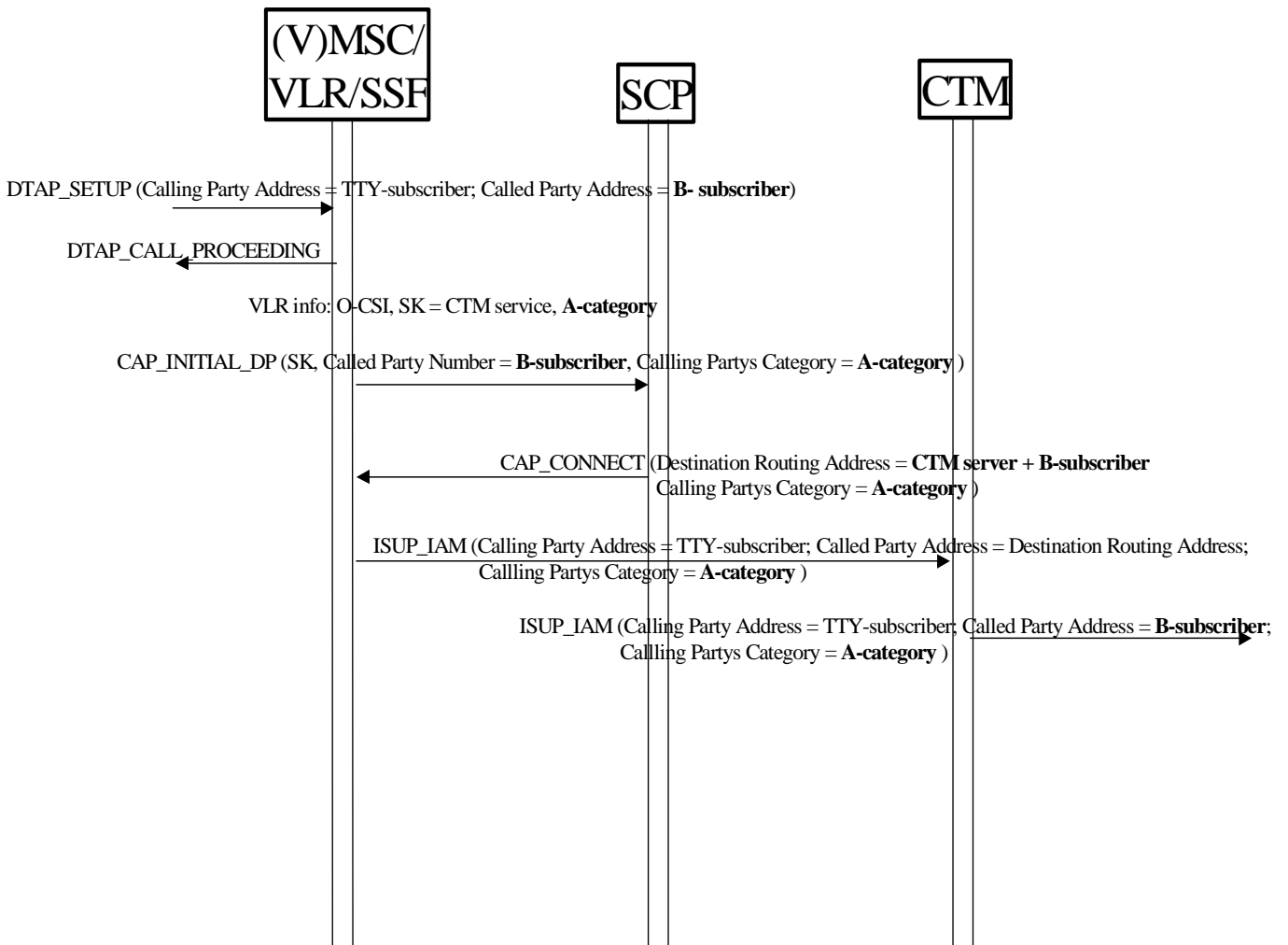

Figure C.6 Mobile Originating Text Call

For normal originating calls the MSC finds the CAMEL text telephony Service Key in the VLR, together with information on the Detection Point = Collection of dialled digits. All non-emergency calls for the user will cause a connection to the text telephone service application in the CTM-SCP. The A-category value from the subscriber data in the VLR is used as CPC value.

The CAMEL service knows that it is an originating call. In this case it just forwards the Calling Party's Category parameter untouched.

The CTM-SRF removes its own address digits from the Called Party Address. The CTM/Text telephone conversion function is inserted before the call is routed towards the B-subscriber.

C.2.3 Mobile to Mobile Calls

Two CTM-SRF servers are linked in, one on the originating leg and one on the terminating leg. The originating ISUP_IAM sent from the CTM-SRF server on the outgoing side is received by the GMSC as normal ISUP_IAM.

C.3 Routing actions of the CTM-SCP

From the sections above, it can be derived that the following actions are performed in the CAMEL server CTM-SCP acting on the CAP Interface.

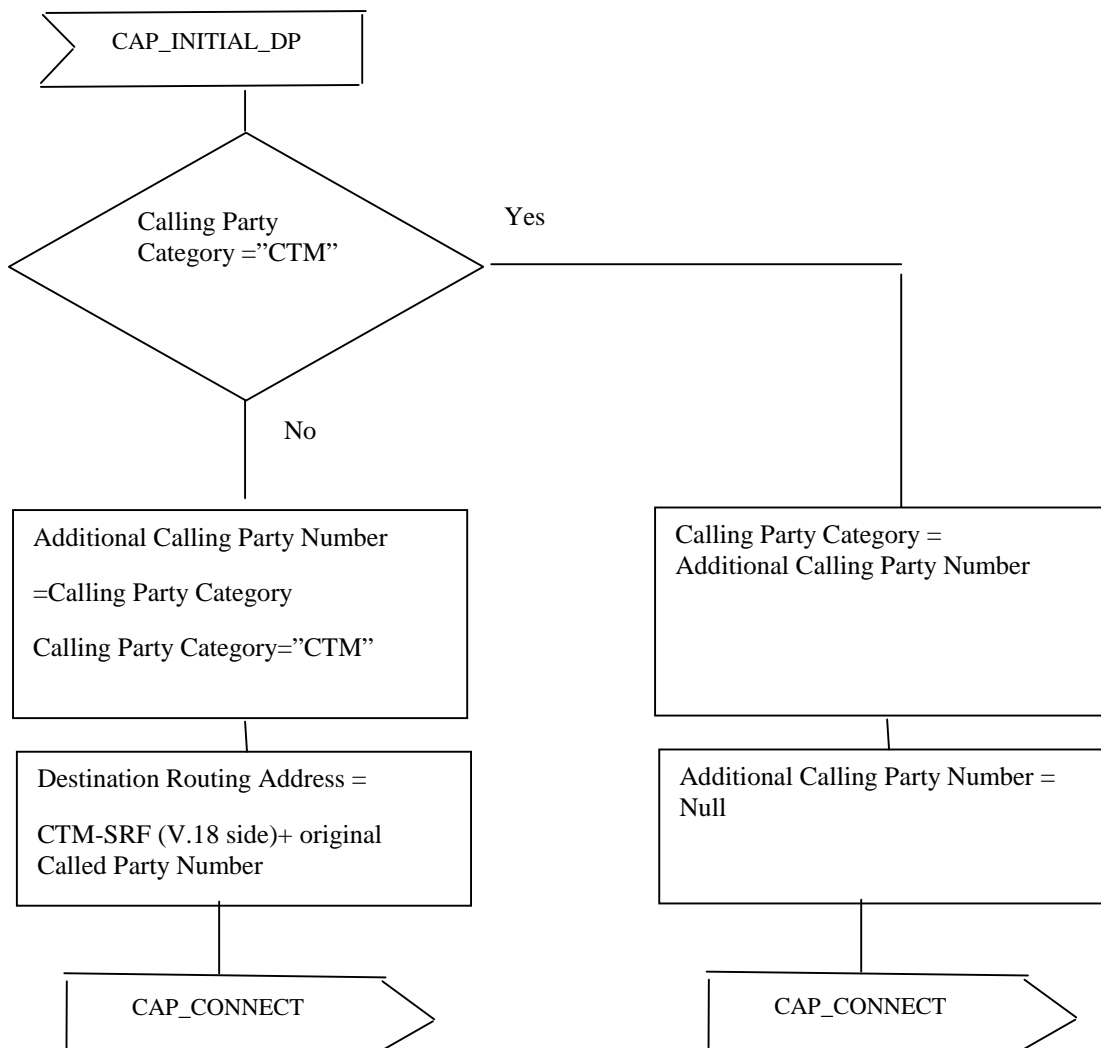

Figure C.7: CTM-SCP Logic for Mobile Terminated case. Detection point =Terminating Attempt Authorized

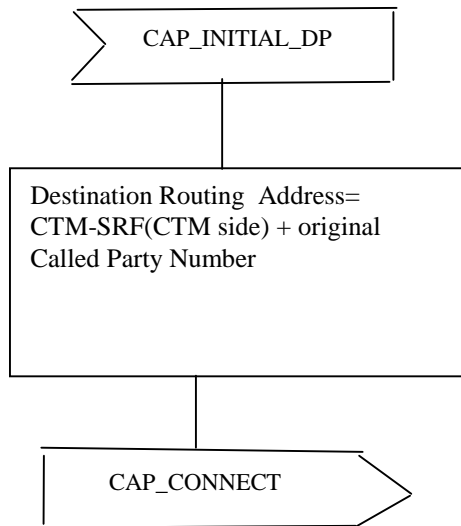

Figure C.8: CTM_SCP logic for Mobile Originated case at detection point=Collection of dialled digits

C.4 Routing actions of the CTM-SRF

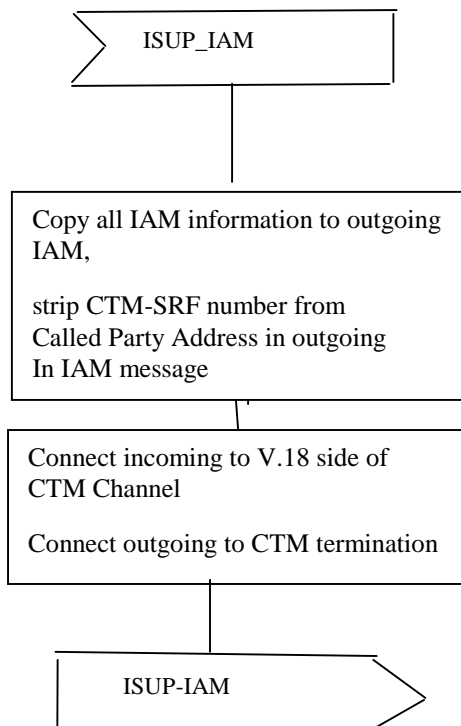

Figure C.9: Routing logic in CTM-SRF for Mobile terminated calls

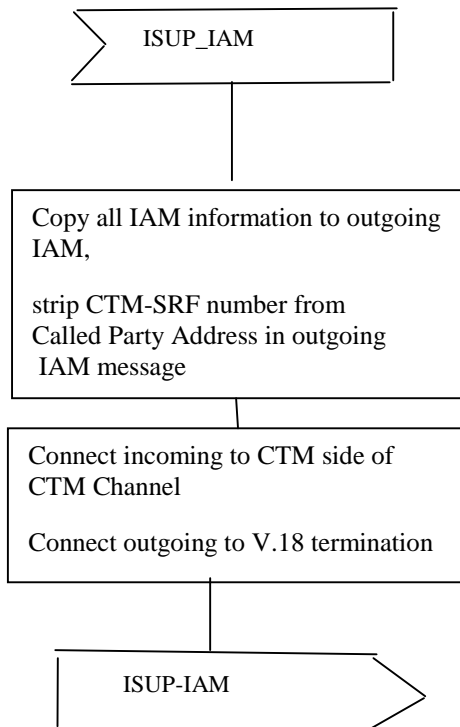

Figure C.10: Routing logic in CTM-SRF, for Mobile Originated calls

C.5 Service interactions

C.5.1 Interaction with other CAMEL services

The text users can use other CAMEL services. However, with other CAMEL services using the same Detection Point as the Text Telephone service, the other CAMEL services are impacted when using CAMEL Phase 1 as presented in this document.

As for the impact on existing CAMEL services, some of the services may be impacted anyway to support text users, for example Prepaid for playing announcement in text telephone signals.

Every CAMEL service, which is expected to be used by both voice and text users, and use the same CAMEL detection point as the GTT service, is assigned two SKs, one for non-text users and another for text users. For text users the other service logic has to integrate CTM-SCP routing logic.

C.5.2 Interactions with Supplementary Services

In general, no other interactions are expected than described in the CAMEL standard.

Call Forwarding in GMSC is invoked after terminating CAMEL service invocation. This means the CTM-SRF service node is already linked in the call path. A further invocation of a mobile originated CAMEL based service will cause an additional routing to a CTM-SRF service node. This is needed to convert the text back to text telephone coding, e.g. Baudot, which is required for the following routing towards the forwarded-to-party (C-party).

C.5.3 Emergency Call interaction

New emergency call categories introduced in 3GPP Release 4 (introduced as emergency-call enhancement) have no impact on routing of emergency calls via CTM-SRF server.

New categories may be specified in order to detect text emergency calls.

C.5.4 Usage of Destination Routing Address

The Destination Routing Address CAMEL parameter is used by the service logic for two purposes.

- It contains the CTM-SRF server address to let the MSC to route the call to the CTM-SRF server.
- It contains the original B-subscriber address, to let the CTM-SRF server to use it as Called Party Number on the outgoing side.

When the service logic reconnects the CTM-SRF server, the service has to save the Nature of Address and the Numbering Plan Indicator of the original Called Party Number in the Destination Routing Address parameter.

CAMEL Phase 1 Destination Routing Address has up to 12 octets. Two octets are needed to encode Nature of Address and the Numbering Plan Indicator. This means that 10 octets are left for CTM-SRF server address digits plus Called Party Address digits. All together 20 digits are given.

An international one up to 15 digits according E.164. This results in having 5 digits left for CTM-SRF server addressing.

C.5.5 Inserting CTM/Text telephone conversion function

The CTM/Text telephone conversion function is direction oriented. A CTM modem should be connected towards the radio side and a modem for V.18 or any of its text telephone submodes towards the other direction. Therefore the CTM-SRF server has to distinguish between mobile terminating and mobile originating calls.

This can be achieved by either allocating different channels for the directions or make decision based on the Called number to the CTM-SRF.

C.5.6 Lawful interception

Depending on where on the route the intercept is made, and also depending on the support for CTM in the terminal, the coding in the intercept point will be transmitted in CTM modulation and coding, or native PSTN text telephone coding and modulation. Both are possible to decode, and a combined decoder can be designed.

Note: In some countries it is required that all PLMN specific codings are decoded before the lawful interception. In this case operators must upgrade their lawful interception equipment.

History

Document history		
V. 0.0.2	May 2000	Initial Draft
V.0.0.3	Aug 7, 2000	Changes according to evolving total R'2000 architecture
V 0.0.4	Sep 1, 2000	Improved structure and detailing of some procedures
V.0.0.5	Feb 21, 2001	Alignment with R-4 and R-5 architecture
V.0.0.6	May 8, 2001	Core network location solution for GTT-Voice detailed.
V.0.0.7	May 14, 2001	CTM Circuit pool solution merged into the document.
v.2.0.0	June 17, 2001	Raised to version 2 to be presented for approval at SA#12 (same technical content as v.0.0.7)
