

**Source:** T3

**Title:** Response to LS (T2-000793) on discussion document on UE  
functionality split over physical devices

**Document for:**

**Agenda Item:**

---

**3GPP TSG-T (Terminals) Meeting #11  
Palm Springs, USA, 14 - 16 March, 2001**

***Tdoc TP-010066***

3GPP T3 Meeting #18  
Sophia Antipolis, France, 1 - 2 March, 2001

*Tdoc T3-010250*

### **Liaison Statement**

**From:** T3

**To:** T2, SA3, T, CN1

**Cc:** SA, SA1, SA2

**Subject:** Response to LS (T2-000793) on discussion document on UE functionality  
split over physical devices

**Contact:** Ileana Leuca (ileana.leuca@attws.com) +1 425 580 7900  
Sonia Compans(sonia.compans@gemplus.com) +33 4 42 36 44 47

---

On 22-23 of February, a joint ad-hoc meeting between TSG-T2 and TSG-T3 addressed the UE functionality split over physical devices, a subject raised in T2-000793. The group has analysed a draft document outlining different cases in a "car pooling" scenario. T3 is glad to share the group's current understanding on this matter.

The analysis was USIM/UICC centric and based on the following considerations:

- ◆ A UICC/USIM is required to access the 3G network.
- ◆ Charging is linked to one particular USIM.
- ◆ The secret key and the authentication algorithm cannot be transferred out from the UICC.
- ◆ A periodic UICC presence detection is mandatory during a call.

The group decided to assemble a set of cases based on a generic issue such as billing associated with different subscriptions, when a user(s) uses one or multiple devices.

Based on the fact that the subscription information is stored in a USIM and that the USIM application resides on a UICC, four cases were identified (see Annex 1).

This is only an initial analysis. T3 believes that a security study and a feasibility study on the architectural aspects of these USIM/UICC models should define a minimum number of models by eliminating the ones violating the 3G security and architecture requirements.

Should other groups have to amend the set of cases, based on other factors, TSG-T3 will be happy to re-visit this subject.

T3 looks forward to future fruitful co-operation on this topic.

|

# ANNEX 1: A Use Case Example – The Car Pool

## Case 1

In this case, multiple users, (e.g. one, two or three) use one subscription and its information is stored in one USIM/UICC as shown in Fig. 1. For the car pool scenario, the car module has its own UICC with one USIM and all the passengers use this subscription. The user(s) identity is different from the subscribers' identity.

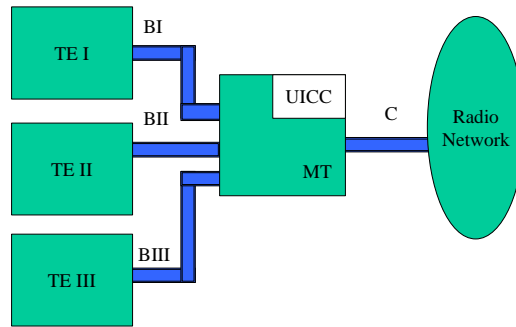

Figure 1 – Multiple users, one “borrowed” subscriber identity.

Multiple independent 3G paths through the network are required.

## Case 2

In this case, multiple users use multiple subscriptions residing in one UICC. For the car pool scenario, the car module has its own UICC with several USIMs and each user accesses different services using a dedicated USIM (every usage is metered). The billing is associated with the subscriber's identity stored in the USIMs.

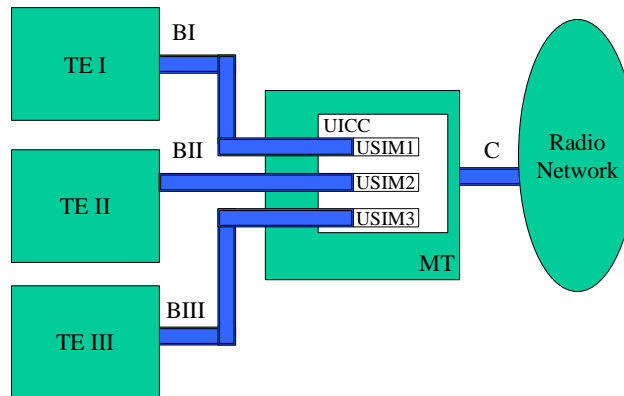

Figure 2 - Multiple users, multiple “borrowed” subscriber identities.

Multiple independent 3G paths through the network are required. In release 99 we may have multiple USIMs stored on a UICC but they cannot be all active at the same time. In release 4, the support of logical channels enables multiple USIM activation. However, further studies are needed on the terminal and network sides regarding the support of multiple active USIM calls/sessions simultaneously.

### Case 3

In this case, every user uses subscription per device and each device (e.g. PC, PDA) has an UICC/USIM. For the car pool scenario, the car module does not use an USIM/UICC, even if an USIM/UICC is physically present in the car module.

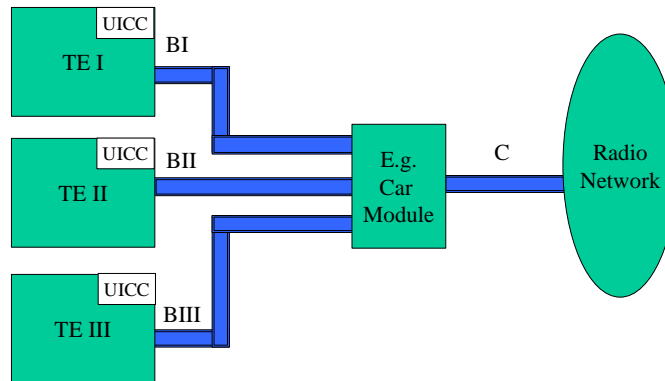

Figure 3 - Multiple users, multiple “owned” subscriber identities.

Two scenarios can occur

- The car module is used as transmitter with multiplexing capabilities and the CK and the IK are handled by the TEs.
- The car module also handles the CK and IK keys. The transfer of the CK and IK between the TE and the car module can raise a security issue. As one radio link can only be associated with one valid CK/IK, it is assumed that multiple radio transmitters exist on the car module.

This scenario requires each device accessing the 3G network to have a 3G USIM/UICC.

### Case 4

In this scenario, every user has a subscription i.e. each user has one UICC/USIM that resides in a device such as the mobile phone (like in case 3). However, when the user becomes a passenger, in a car pool environment, two approaches are considered:

- The user stops using the UICC of his device and the device notifies the network that from now on, it will use the car module USIM/UICC, as in case 2 (figure 4).
- "Mobile hand-over": the user continues using the initial UICC and the radio transmitter of the car module (figure 4). This case can also evolve into having a second TE using the UICC from the ME and using the radio transmitter from the car module (figure 5).

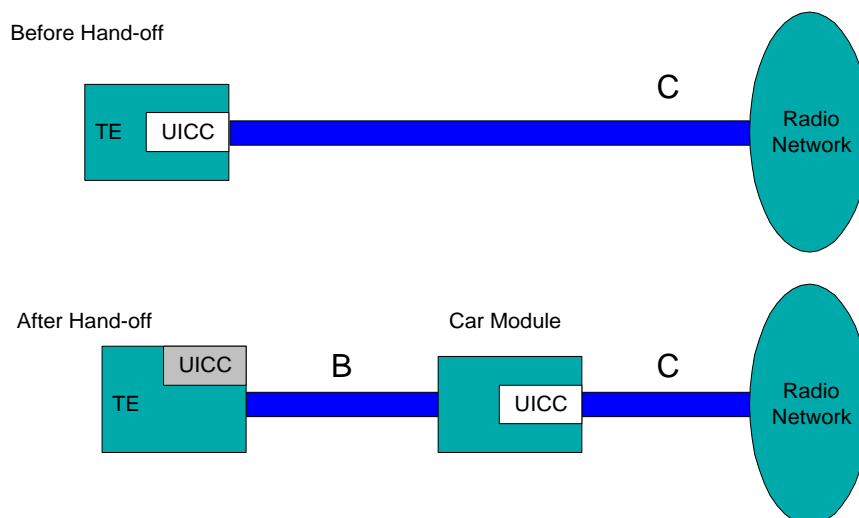
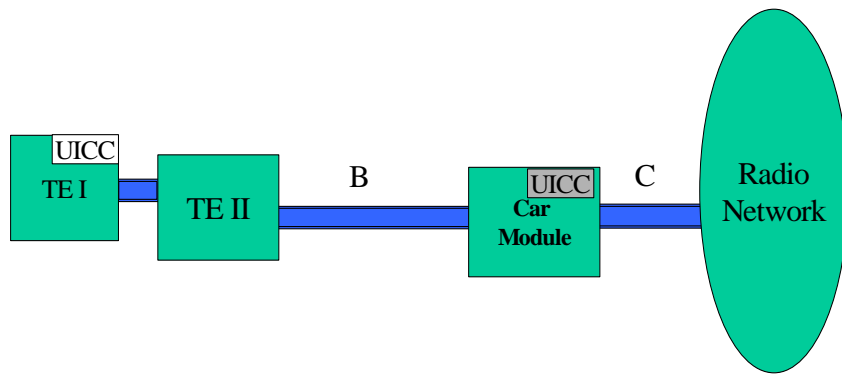

Figure 4 - Hand-off to a “borrowed” subscriber identity.



**Figure 5 – Hand-off, but retain and lend “own” subscriber identity.**

In the "mobile hand-over" case, the TE transmits the messages, including the CK and IK keys, received from the UICC to the car module through the local link. The transfer of the CK and IK between the TE and the car module can raise a security issue.