

**Source:** TSG\_SA WG4  
**Title:** AMR Wideband Speech Codec; Speech Codec Frame Structure (Release 4)  
**Document for:** Approval

### Presentation of Specification to TSG-SA

---

**Presentation to:** TSG SA Meeting #11  
**Document for presentation:** TS 26.201 Version 2.0.0  
**Presented for:** Approval

---

**Abstract of document:**

The present document describes a generic frame format for the Adaptive Multi-Rate Wideband (AMR-WB) speech codec. This format shall be used as a common reference point when interfacing speech frames between different elements of the 3G system and between different systems. Appropriate mappings to and from this generic frame format will be used within and between each system element.

Annex A describes a second frame format which shall be used when octet alignment of AMR-WB frames is required.

---

**Changes since last presentation to TSG Meeting #10:**

[Editorial changes & Clarifications + Generic Frame Composition defined.](#)

---

**Outstanding Issues:**

[None.](#)

---

**Contentious Issues:**

The LSB/MSB definition in the frame format of AMR-WB is not consistent with that of AMR-NB: the definition on MSB first to be approved here is for the specification on AMR-WB, and the corresponding definition for AMR-NB in TS 26.101 does not necessarily have to be consistent with it.

# 3GPP TS 26.201 V2.0.0 (2001-03)

---

*Technical Specification*

**3rd Generation Partnership Project;  
Technical Specification Group Services and System Aspects;  
Speech Codec speech processing functions;  
AMR Wideband Speech Codec; Frame Structure  
(Release 4)**



The present document has been developed within the 3<sup>rd</sup> Generation Partnership Project (3GPP™) and may be further elaborated for the purposes of 3GPP.

The present document has not been subject to any approval process by the 3GPP Organizational Partners and shall not be implemented. This Specification is provided for future development work within 3GPP only. The Organizational Partners accept no liability for any use of this Specification. Specifications and reports for implementation of the 3GPP™ system should be obtained via the 3GPP Organizational Partners' Publications Offices.

---

Keywords

---

AMR, CODEC, Adaptive Multi-Rate, Wideband  
speech coder

**3GPP**

Postal address

---

3GPP support office address

---

650 Route des Lucioles - Sophia Antipolis  
Valbonne - FRANCE  
Tel.: +33 4 92 94 42 00 Fax: +33 4 93 65 47 16

Internet

---

<http://www.3gpp.org>

---

**Copyright Notification**

---

No part may be reproduced except as authorized by written permission.  
The copyright and the foregoing restriction extend to reproduction in all media.

© 2001, 3GPP Organizational Partners (ARIB, CWTS, ETSI, T1, TTA, TTC).  
All rights reserved.

---

# Contents

Foreword.....	4
1 Scope .....	5
2 References .....	5
3 Definitions and Abbreviations .....	5
3.1 Definitions.....	5
3.2 Abbreviations.....	5
4 AMR-WB codec Interface format 1 (AMR-WB IF1).....	6
4.1 AMR-WB Header and AMR-WB Auxiliary Information.....	6
4.1.1 Frame Type, Mode Indication, and Mode Request .....	6
4.1.2 Frame Quality Indicator .....	7
4.1.3 Mapping to TX_TYPE and RX_TYPE.....	7
4.1.4 Codec CRC.....	8
4.2 AMR-WB Core Frame.....	8
4.2.1 AMR-WB Core Frame with speech bits: Bit ordering .....	8
4.2.2 AMR-WB Core Frame with speech bits: Class division.....	8
4.2.3 AMR-WB Core Frame with comfort noise bits .....	9
4.3 Generic AMR-WB Frame Composition .....	10
<b>Annex A (normative): AMR-WB Interface Format 2 (with octet alignment).....</b>	<b>12</b>
<b>Annex B (normative): Tables for AMR-WB Core Frame bit ordering .....</b>	<b>14</b>
<b>Annex C (informative): Change history .....</b>	<b>22</b>

---

# Foreword

This Technical Specification (TS) has been produced by the 3<sup>rd</sup> Generation Partnership Project (3GPP).

The contents of the present document are subject to continuing work within the TSG and may change following formal TSG approval. Should the TSG modify the contents of the present document, it will be re-released by the TSG with an identifying change of release date and an increase in version number as follows:

Version x.y.z

where:

- x the first digit:
  - 1 presented to TSG for information;
  - 2 presented to TSG for approval;
  - 3 or greater indicates TSG approved document under change control.
- y the second digit is incremented for all changes of substance, i.e. technical enhancements, corrections, updates, etc.
- z the third digit is incremented when editorial only changes have been incorporated in the document.

---

# 1 Scope

The present document describes a generic frame format for the Adaptive Multi-Rate Wideband (AMR-WB) speech codec. This format shall be used as a common reference point when interfacing speech frames between different elements of the 3G system and between different systems. Appropriate mappings to and from this generic frame format will be used within and between each system element.

Annex A describes a second frame format which shall be used when octet alignment of AMR-WB frames is required.

---

# 2 References

The following documents contain provisions which, through reference in this text, constitute provisions of the present document.

- References are either specific (identified by date of publication, edition number, version number, etc.) or non-specific.
- For a specific reference, subsequent revisions do not apply.
- For a non-specific reference, the latest version applies.

[1] 3GPP TS 26.190: "AMR Wideband Speech Codec; Speech Transcoding Functions".

[2] 3GPP TS 26.193: "AMR Wideband Speech Codec; Source Controlled Rate Operation".

[3] 3GPP TS 26.192: "AMR Wideband Speech Codec; Comfort Noise Aspects".

---

# 3 Definitions and Abbreviations

## 3.1 Definitions

For the purposes of the present document, the following terms and definitions apply:

**AMR-WB mode:** one of the nine AMR-WB codec bit-rates denoted also with indices 0 to 8 where 0 maps to the 6.60 kbit/s mode and 8 maps to the 23.85 kbit/s mode.

**AMR-WB codec mode:** same as AMR-WB mode.

**RX\_TYPE:** classification of the received frame as defined in [2].

**TX\_TYPE:** classification of the transmitted frame as defined in [2].

## 3.2 Abbreviations

For the purposes of the present document, the following abbreviations apply:

CRC	Cyclic Redundancy Check
FQI	Frame Quality Indicator
GSM	Global System for Mobile communication
LSB	Least Significant Bit
MSB	Most Significant BitRX Receive
SCR	Source Controlled Rate operation
SID	Silence Descriptor (Comfort Noise Frame)
TX	Transmit

## 4 AMR-WB codec Interface format 1 (AMR-WB IF1)

This clause describes the generic frame format for both the speech and comfort noise frames of the AMR-WB speech codec. This format is referred to as AMR-WB Interface Format 1 (AMR-WB IF1). Annex A describes AMR-WB Interface Format 2 (AMR-WB IF2).

Each AMR-WB codec mode follows the generic frame structure depicted in figure 1. The frame is divided into three parts: AMR-WB Header, AMR-WB Auxiliary Information, and AMR-WB Core Frame. The AMR-WB Header part includes the Frame Type and the Frame Quality Indicator fields. The AMR-WB auxiliary information part includes the Mode Indication, Mode Request, and Codec CRC fields. The AMR-WB Core Frame part consists of the speech parameter bits or, in case of a comfort noise frame, the comfort noise parameter bits. In case of a comfort noise frame, the comfort noise parameters replace Class A bits of AMR-WB Core Frame while Class B and C bits are omitted.

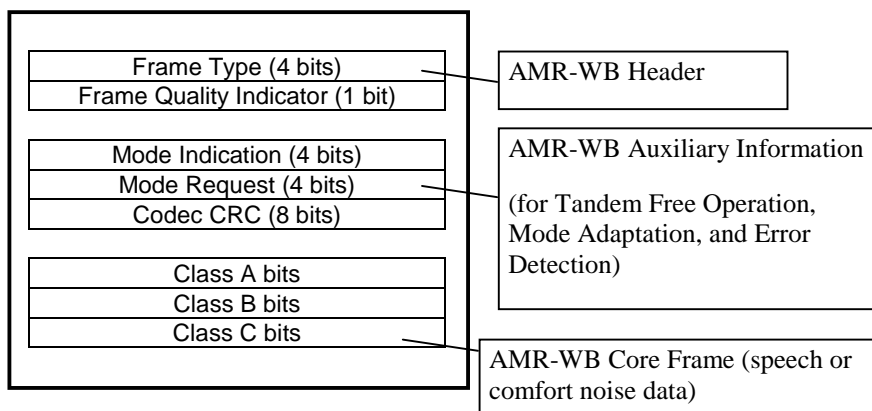

Figure 1. Generic AMR-WB frame structure

### 4.1 AMR-WB Header and AMR-WB Auxiliary Information

This subclause describes the AMR-WB Header of figure 1.

#### 4.1.1 Frame Type, Mode Indication, and Mode Request

Table 1a defines the 4-bit Frame Type field. Frame Type can indicate the use of one of the nine AMR-WB codec modes, comfort noise frame, lost speech frame, or an empty frame. In addition, four Frame Type Indices are reserved for future use. The same table is reused for the Mode Indication and Mode Request fields which are 4-bit fields each and are defined only in the range 0...8 to specify one of the nine AMR-WB codec modes.

**Table 1a: Interpretation of Frame Type, Mode Indication and Mode Request fields.**

Frame Type Index	Mode Indication	Mode Request	Frame content (AMR-WB mode, comfort noise, or other)
0	0	0	AMR-WB 6.60 kbit/s
1	1	1	AMR-WB 8.85 kbit/s
2	2	2	AMR-WB 12.65 kbit/s
3	3	3	AMR-WB 14.25 kbit/s
4	4	4	AMR-WB 15.85 kbit/s
5	5	5	AMR-WB 18.25 kbit/s
6	6	6	AMR-WB 19.85 kbit/s
7	7	7	AMR-WB 23.05 kbit/s
8	8	8	AMR-WB 23.85 kbit/s
9	-	-	AMR-WB SID (Comfort Noise Frame)
10-13	-	-	For future use
14	-	-	speech lost
15	-	-	No Data (No transmission/No reception)
	-	-	

#### 4.1.2 Frame Quality Indicator

The content of the Frame Quality Indicator field is defined in Table 1b. The field length is one bit. The Frame Quality Indicator indicates whether the data in the frame contains errors.

**Table 1b: Definition of Frame Quality Indicator**

Frame Quality Indicator (FQI)	Quality of data
0	Bad frame or Corrupted frame (bits may be used to assist error concealment)
1	Good frame

#### 4.1.3 Mapping to TX\_TYPE and RX\_TYPE

Table 1c shows how the AMR-WB Header data (FQI and Frame Type) maps to the TX\_TYPE and RX\_TYPE frames defined in [2].

**Table 1c: Mapping of Frame Quality Indicator and Frame Type to TX\_TYPE and RX\_TYPE [2], respectively**

Frame Quality Indicator	Frame Type Index	TX_TYPE or RX_TYPE	Comment
1	0-8	SPEECH_GOOD	The specific Frame Type Index depends on the bit-rate being used.
0	0-8	SPEECH_BAD	The specific Frame Type Index depends on the bit-rate being used. The corrupted data may be used to assist error concealment.
0	14	SPEECH_LOST	No useful information. An erased or stolen frame with no data usable to assist error concealment.
1	9	SID_FIRST or SID_UPDATE	SID_FIRST and SID_UPDATE are differentiated using one Class A bit: STI.
0	9	SID_BAD	
1	15	NO_DATA	Typically a non-transmitted frame.



#### 4.1.4 Codec CRC

Generic AMR-WB codec frames with Frame Type 0...9 are associated with an 8-bit CRC for error-detection purposes. The Codec CRC field of AMR-WB Auxiliary Information in figure 1 contains the value of this CRC. These eight parity bits are generated by the cyclic generator polynomial:

$$- G(x)=D^8 + D^6 + D^5 + D^4 + 1$$

which is computed over all Class A bits of AMR-WB Core Frame. Class A bits for Frame Types 0...8 are defined in subclause 4.2.2 (for speech bits) and for Frame Type 9 in subclause 4.2.3 (for comfort noise bits).

When Frame Type Index of table 1a is 14 or 15, the CRC field is not included in the Generic AMR-WB frame.

### 4.2 AMR-WB Core Frame

This subclause contains the description of AMR-WB Core Frame of figure 1. The descriptions for AMR-WB Core Frame with speech bits and with comfort noise bit are given separately.

#### 4.2.1 AMR-WB Core Frame with speech bits: Bit ordering

This subclause describes how AMR-WB Core Frame carries the coded speech data. The bits produced by the speech encoder are denoted as  $\{s(1),s(2),\dots,s(K)\}$ , where  $K$  refers to the number of bits produced by the speech encoder as shown in table 2. The notation  $s(i)$  follows that of [1]. The speech encoder output bits are ordered according to their subjective importance. This bit ordering can be utilized for error protection purposes when the speech data is, for example, carried over a radio interface. Tables B.1 to B.9 in Annex B define the AMR-WB IF1 bit ordering for all the nine AMR-WB codec modes. In these tables the speech bits are numbered in the order they are produced by the corresponding speech encoder as described in the relevant tables of 3GPP TS 26.190 [1]. The reordered bits are denoted below, in the order of decreasing importance, as  $\{d(0),d(1),\dots,d(K-1)\}$ .

The ordering algorithm is described in pseudo code as:

- for  $j = 0$  to  $K-1$
- $d(j) := s(\text{table}_m(j)+1)$ ;

where  $\text{table}_m(j)$  refers to the relevant table in Annex B depending on the AMR-WB mode  $m=0..8$ . The Annex B tables should be read line by line from left to right. The first element of the table has the index 0.

#### 4.2.2 AMR-WB Core Frame with speech bits: Class division

The reordered bits are further divided into three indicative classes according to their subjective importance. The three different importance classes can then be subject to different error protection in the network.

The importance classes are Class A, Class B, and Class C. Class A contains the bits most sensitive to errors and any error in these bits typically results in a corrupted speech frame which should not be decoded without applying appropriate error concealment. This class is protected by the Codec CRC in AMR-WB Auxiliary Information. Classes B and C contain bits where increasing error rates gradually reduce the speech quality, but decoding of an erroneous speech frame is usually possible without annoying artifacts. Class B bits are more sensitive to errors than Class C bits. The importance ordering applies also within the three different classes and there are no significant step-wise changes in subjective importance between neighbouring bits at the class borders.

The number of speech bits in each class (Class A, Class B, and Class C) for each AMR-WB mode is shown in table 2. The classification in table 2 and the importance ordering  $d(j)$ , together, are sufficient to assign all speech bits to their correct classes. For example, when the AMR-WB codec mode is 6.60, then the Class A bits are  $d(0)..d(53)$ , Class B bits are  $d(54)..d(131)$ , and there are no Class C bits.

**Table 2: Number of bits in Classes A, B, and C for each AMR-WB codec mode**

Frame Type	AMR-WB codec mode	Total number of bits	Class A	Class B	Class C
0	6.60	132	54	78	0
1	8.85	177	64	113	0
2	12.65	253	72	181	0
3	14.25	285	72	213	0
4	15.85	317	72	245	0
5	18.25	365	72	293	0
6	19.85	397	72	325	0
7	23.05	461	72	389	0
8	23.85	477	72	405	0

### 4.2.3 AMR-WB Core Frame with comfort noise bits

The AMR-WB Core Frame content for the additional frame types with Frame Type Indices 9-15 in table 1a are described in this subclause. These mainly consist of the frames related to Source Controlled Rate Operation specified in [2].

The data content (comfort noise bits) of the additional frame types is carried in AMR-WB Core Frame. The comfort noise bits are all mapped to Class A of AMR-WB Core Frame and Classes B and C are not used. This is a notation convention only and the class division has no meaning for comfort noise bits.

The number of bits in each class (Class A, Class B, and Class C) for the AMR-WB comfort noise bits (Frame Type Index 9) is shown in table 3. The contents of SID\_UPDATE and SID\_FIRST are divided into three parts (SID Type Indicator (STI), Mode Indication (mi(i)), and Comfort Noise Parameters (s(i)) as defined in [2].

The comfort noise parameter bits produced by the AMR-WB speech encoder are denoted as  $s(i) = \{s(1), s(2), \dots, s(35)\}$ . The notation  $s(i)$  follows that of [3]. These bits are numbered in the order they are produced by the AMR-WB encoder without any reordering. These bits are followed by the SID Type Indicator STI and the Mode Indication bits  $mi(i) = \{mi(0), mi(1), mi(2), mi(3)\} = \{\text{LSB} :: \text{MSB}\}$ . Thus, the AMR-WB SID or comfort noise bits  $\{d(0), d(1), \dots, d(39)\}$  are formed as defined by the pseudo code below.

- for  $j = 0$  to 34;
- $d(j) := s(j+1)$ ;
- $d(35) := \text{STI}$ ;
- for  $j = 36$  to 39;
- $d(j) := \text{smi}(39-j)$ .

**Table 3. Bit classification for Frame Type 9: AMR-WB SID (Comfort Noise Frame)**

Frame Type Index	FQI	AMR-WB TX_TYPE or RX_TYPE	Total number of bits	Class A			Class B	Class C
				SID Type Indicator STI	Mode Indication mi(i)	Comfort Noise Parameter s(i)		
9	1	SID_UPDATE	40	1 (= "1")	4	35	0	0
9	1	SID_FIRST	40	1 (= "0")	4	35 (= "0")	0	0
9	0	SID_BAD	40	1	4	35	0	0

AMR-WB no transmission frame type (14 or 15) contains the AMR-WB Header information (as defined in Figure 1), while AMR-WB Auxiliary Information and AMR-WB Core frame are omitted. The AMR-WB Header includes the corresponding Frame Type and the Frame Quality Indicator (as defined in table 1c).

### 4.3 Generic AMR-WB Frame Composition

The generic AMR-WB frame is formed as a concatenation of AMR-WB Header, AMR-WB Auxiliary Information and the AMR-WB Core Frame, in this order. The MSB of the Frame Type is placed in bit 8 of the first octet (see example in table 5 below), the LSB of the Frame Type is placed in bit 5. Then the next parameter follows, which is the Frame Quality Indicator, and so on. After FQI, three spare bits are inserted to align the Codec CRC and the AMR-WB Core frame to the octet boundary. The first bit of the AMR-WB Core frame d(0) is placed in bit 8 of octet 4. The last bit of the generic AMR-WB frame is the last bit of AMR-WB Core Frame, which is the last bit of speech bits or the last bit of comfort noise bits, as defined in subclauses 4.2.1 and 4.2.3. Table 5 shows the composition for the example of the Codec Mode 12.65 kbit/s and table 6 shows the composition for the AMR-WB SID frame.

**Table 5: Mapping of an AMR-WB speech coding mode into the generic AMR-WB frame, AMR-WB IF1, example: AMR-WB 12.65 kbit/s (Mode Indication = 3), "good frame", Mode Request = 1.**

Octet	Mapping of bits AMR-WB 12.65							LSB bit 1
	MSB bit 8	bit 7	bit 6	bit 5	bit 4	bit 3	bit 2	
1	Frame Type (=3)				FQI	spare		
	0	0	1	1	1	0	0	0
2	Mode Indication (=3)			Mode Request (=1)				
	MSB	...	LSB	MSB	...	LSB		
	0	0	1	1	0	0	0	1
3	Codec CRC							
	CRC(7)	CRC(6)	CRC(5)	CRC(4)	CRC(3)	CRC(2)	CRC(1)	CRC(0)
4	AMR-WB Core Frame (octet 1)							
	d(0)	d(1)	d(2)	d(3)	d(4)	d(5)	d(6)	d(7)
5..34	AMR-WB Core Frame (octets 2 to 31)							
	d(8)	...	...	...	...	...	...	...
35	AMR-WB Core Frame (octet 32)					undefined		
	d(248)	d(249)	d(250)	d(251)	d(252)			

**Table 6: Mapping of an AMR-WB SID frame into the generic AMR-WB frame, AMR-WB IF1, example: AMR-WB SID\_Update, "good frame", Mode Indication = 3, Mode Request = 2.**

Octet	Mapping of bits AMR-WB SID							LSB bit 1
	MSB bit 8	bit 7	bit 6	bit 5	bit 4	bit 3	bit 2	
1	Frame Type (=9)				FQI	spare		
	1	0	0	0	1	0	0	0
2	Mode Indication			Mode Request (=2)				
	undefined				MSB	...	LSB	
				0	0	1	0	
3	Codec CRC							
	CRC(7)	CRC(6)	CRC(5)	CRC(4)	CRC(3)	CRC(2)	CRC(1)	CRC(0)
4	AMR-WB Core Frame (octet 1)							
	d(0)=s(1)	d(1)=s(2)	d(2)	d(3)	d(4)	d(5)	d(6)	d(7)
5..7	AMR-WB Core Frame (octets 2 to 4)							
	d(8)	...	...	...	...	...	...	...
8	AMR-WB Core Frame (octet 5)			STI	Mode Indication (=3)			
	d(32)	d(33)	d(34) = s(35)	1	MSB	...	LSB	
				1	0	0	1	1

Table 7 summarizes all possible AMR-WB frame format combinations in terms of number of bits in each field.

Table 7. Number of bits for different fields in different AMR-WB frame compositions

Frame Type Index	Frame Type	Frame Quality Indicator	Mode Indication	Mode Request	Codec CRC	Class A	Class B	Class C	Total
						<b>AMR-WB Core Frame</b>			
0	4	1	4	4	8	54	78	0	153
1	4	1	4	4	8	64	113	0	198
2	4	1	4	4	8	72	181	0	274
3	4	1	4	4	8	72	213	0	306
4	4	1	4	4	8	72	245	0	338
5	4	1	4	4	8	72	293	0	386
6	4	1	4	4	8	72	325	0	418
7	4	1	4	4	8	72	389	0	482
8	4	1	4	4	8	72	405	0	498
9	4	1	4	4	8	40	0	0	61
10-13	Not used								
14	4	1	0	0	0	0	0	0	4
15	4	1	0	0	0	0	0	0	4

## Annex A (normative): AMR-WB Interface Format 2 (with octet alignment)

This annex defines an octet-aligned frame format for the AMR-WB codec. This format is useful, for example, when the AMR-WB codec is used in connection with applicable ITU-T H-series of recommendations. The format is referred to as AMR-WB Interface Format 2 (AMR-WB IF2).

The AMR-WB IF2 frame is formed by concatenation of the 4-bit Frame Type field (as defined for AMR-WB IF1 in subclause 4.1.1), the 1-bit Frame Quality Indicator field (as defined for AMR-WB IF1 in subclause 4.1.2) and the AMR-WB Core Frame (as defined for AMR-WB IF1 in subclause 4.2) as shown in figure A.1. The length of the AMR-WB Core Frame field depends on the particular Frame Type. The total number of bits in the AMR-WB IF2 speech frames in the different modes is typically not a multiple of eight and bit stuffing is needed to achieve an octet structure.

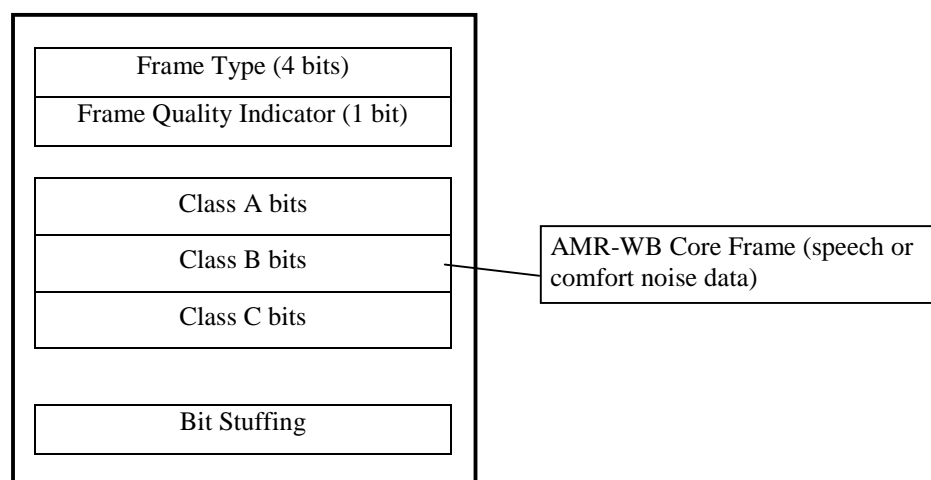

**Figure A.1: Frame structure for AMR-WB IF2**

Table A.1a shows an example how the AMR-WB 8.85 kbit/s mode is mapped into AMR-WB IF2. The four MSBs of the first octet (octet 1) consist of the Frame Type (=1) for the AMR-WB 8.85 kbit/s mode (see table 1a in AMR-WB IF1 specification) and the Frame Quality Indicator bit. This field is followed by the 177 AMR-WB Core Frame speech bits ( $d(0)...d(176)$ ) which consist of 64 Class A bits and 113 Class B bits as described in table 2 for AMR-WB IF1. This results in a total of 182 bits and 2 bits are needed for Bit Stuffing to arrive to the closest multiple of 8 which is 184 bits.

**Table A.1a: Example mapping of the AMR-WB speech coding mode 8.85kbit/s into AMR-WB IF2. The bits used for Bit Stuffing are denoted as UB (for "unused bit").**

Octet	MSB	Mapping of bits AMR-WB 8.85 kbit/s						LSB	
		bit 8	bit 7	bit 6	bit 5	bit 4	bit 3		bit 2
		Frame Type (= 1)							
	MSB	LSB							
1	0	0	0	0	1	FQI	d(0)	d(1)	d(2)
2	d(3)	d(4)	d(5)	d(6)	d(7)	d(8)	d(9)	d(10)	
3...22	d(11)	...	...	...	...	...	...	...	
23	d(171)	d(172)	d(173)	d(174)	d(175)	d(176)	Stuffing bits		
	d(171)	d(172)	d(173)	d(174)	d(175)	d(176)	UB	UB	

Table A.1b shows the composition of AMR-WB IF2 frames for all Frame Types in terms of how many bits are used for each field of figure A.1.

Table A.2 specify how the AMR-WB Core Frame comfort noise bits of Frame Type 9 is mapped to AMR-WB IF2. Table A.3 specifies the mapping for an empty or lost frame ("no transmission" or "speech lost").

Table A.1b: Composition of AMR-WB IF2 Frames for all Frame Types

Frame Type Index	Frame content	Number of bits in Frame Type	Number of bits in Frame Quality Indicator	Number of Bits in AMR-WB Core Frame	Number of Bits in Bit Stuffing	Number of octets (N)
0	AMR-WB 6.60 kbit/s	4	1	132	7	18
1	AMR-WB 8.85 kbit/s	4	1	177	2	23
2	AMR-WB 12.65 kbit/s	4	1	253	6	33
3	AMR-WB 14.25 kbit/s	4	1	285	6	37
4	AMR-WB 15.85 kbit/s	4	1	317	6	41
5	AMR-WB 18.25 kbit/s	4	1	365	6	47
6	AMR-WB 19.85 kbit/s	4	1	397	6	51
7	AMR-WB 23.05 kbit/s	4	1	461	6	59
8	AMR-WB 23.85 kbit/s	4	1	477	6	61
9	AMR-WB SID (Comfort Noise Frame)	4	1	40	3	6
10-13	For future use	-	-	-	-	-
14	speech lost	4	1	0	3	1
15	No Data (No transmission/No reception)	4	1	0	3	1

Table A.2: Mapping of bits for Frame Type 9 (AMR-WB SID)  
(Bits s1 to s35 refer to TS 26.192)

	MSB	Mapping of bits AMR-WB SID						LSB
Octet	bit 8	bit 7	bit 6	bit 5	bit 4	bit 3	bit 2	bit 1
	Frame Type (= 9)							
	MSB	.....	LSB					
1	1	0	0	1	FQI	s1	s2	s3
2	s4	s5	s6	s7	s8	s9	s10	s11
3	s12	s13	s14	s15	s16	s17	s18	s19
4	s20	s21	s22	s23	s24	s25	s26	s27
5	s28	s29	s30	s31	s32	s33	s34	s35
	SID Type Indicator	Mode Indication mi(i)				Stuffing bits		
6	t1	mi(3)	mi(2)	mi(1)	mi(0)	UB	UB	UB

Definitions of additional descriptor bits needed for the silence descriptor in the table are as follows: SID-type Indicator STI is {0=SID\_FIRST, 1=SID\_UPDATE }, Speech Mode Indication (mi(0)- mi(3)) is the AMR-WB codec mode according to the first nine entries in table 1a. Note that in parameter mi the index 3 refers to MSB.

Table A.3: Mapping of bit for Frame Type 14 (Speech Lost) and for Frame Type 15 (No Data)

Transmitted Octets	MSB	Mapping of bits						LSB
	Frame Type 14 = 1 1 1 0			Frame Type 15 = 1 1 1 1			Stuffing bits	
1	mi(3)	mi(2)	mi(1)	mi(0)	FQI	UB	UB	UB

## Annex B (normative): Tables for AMR-WB Core Frame bit ordering

This annex contains the tables required for ordering the AMR-WB Core Frame speech bits corresponding to the different AMR-WB modes. These tables represent  $table_m(j)$  in subclause 4.2.1 where  $m=0..8$  is the AMR-WB mode. The tables are read from left to right so that the first element (top left corner) of the table has index 0 and the last element (the rightmost element of the last row) has the index  $K-1$  where  $K$  is the total number of speech bits in the specific mode. For example,  $table_0(20)=60$ , as defined in table B.1.

**Table B.1: Ordering of the speech encoder bits for the 6.60 kbit/s mode:  $table_0(j)$**

0	5	6	7	61	84	107	130	62	85
8	4	37	38	39	40	58	81	104	127
60	83	106	129	108	131	128	41	42	80
126	1	3	57	103	82	105	59	2	63
109	110	86	19	22	23	64	87	18	20
21	17	13	88	43	89	65	111	14	24
25	26	27	28	15	16	44	90	66	112
9	11	10	12	67	113	29	30	31	32
34	33	35	36	45	51	68	74	91	97
114	120	46	69	92	115	52	75	98	121
47	70	93	116	53	76	99	122	48	71
94	117	54	77	100	123	49	72	95	118
55	78	101	124	50	73	96	119	56	79
102	125								

**Table B.2: Ordering of the speech encoder bits for the 8.85 kbit/s mode:  $table_1(j)$**

0	4	6	7	5	3	47	48	49	112
113	114	75	106	140	171	80	111	145	176
77	108	142	173	78	109	143	174	79	110
144	175	76	107	141	172	50	115	51	2
1	81	116	146	19	21	12	17	18	20
16	25	13	10	14	24	23	22	26	8
15	52	117	31	82	147	9	33	11	83
148	53	118	28	27	84	149	34	35	29
46	32	30	54	119	37	36	39	38	40
85	150	41	42	43	44	45	55	60	65
70	86	91	96	101	120	125	130	135	151
156	161	166	56	87	121	152	61	92	126
157	66	97	131	162	71	102	136	167	57
88	122	153	62	93	127	158	67	98	132
163	72	103	137	168	58	89	123	154	63
94	128	159	68	99	133	164	73	104	138
169	59	90	124	155	64	95	129	160	69
100	134	165	74	105	139	170			

**Table B.3: Ordering of the speech encoder bits for the 12.65 kbit/s mode:  $table_2(j)$** 

0	4	6	93	143	196	246	7	5	3
47	48	49	50	51	150	151	152	153	154
94	144	197	247	99	149	202	252	96	146
199	249	97	147	200	250	100	203	98	148
201	251	95	145	198	248	52	2	1	101
204	155	19	21	12	17	18	20	16	25
13	10	14	24	23	22	26	8	15	53
156	31	102	205	9	33	11	103	206	54
157	28	27	104	207	34	35	29	46	32
30	55	158	37	36	39	38	40	105	208
41	42	43	44	45	56	106	159	209	57
66	75	84	107	116	125	134	160	169	178
187	210	219	228	237	58	108	161	211	62
112	165	215	67	117	170	220	71	121	174
224	76	126	179	229	80	130	183	233	85
135	188	238	89	139	192	242	59	109	162
212	63	113	166	216	68	118	171	221	72
122	175	225	77	127	180	230	81	131	184
234	86	136	189	239	90	140	193	243	60
110	163	213	64	114	167	217	69	119	172
222	73	123	176	226	78	128	181	231	82
132	185	235	87	137	190	240	91	141	194
244	61	111	164	214	65	115	168	218	70
120	173	223	74	124	177	227	79	129	182
232	83	133	186	236	88	138	191	241	92
142	195	245							



Table B.4: Ordering of the speech encoder bits for the 14.25 kbit/s mode:  $table_3(j)$ 

0	4	6	101	159	220	278	7	5	3
47	48	49	50	51	166	167	168	169	170
102	160	221	279	107	165	226	284	104	162
223	281	105	163	224	282	108	227	106	164
225	283	103	161	222	280	52	2	1	109
228	171	19	21	12	17	18	20	16	25
13	10	14	24	23	22	26	8	15	53
172	31	110	229	9	33	11	111	230	54
173	28	27	112	231	34	35	29	46	32
30	55	174	37	36	39	38	40	113	232
41	42	43	44	45	56	114	175	233	62
120	181	239	75	133	194	252	57	115	176
234	63	121	182	240	70	128	189	247	76
134	195	253	83	141	202	260	92	150	211
269	84	142	203	261	93	151	212	270	85
143	204	262	94	152	213	271	86	144	205
263	95	153	214	272	64	122	183	241	77
135	196	254	65	123	184	242	78	136	197
255	87	145	206	264	96	154	215	273	58
116	177	235	66	124	185	243	71	129	190
248	79	137	198	256	88	146	207	265	97
155	216	274	59	117	178	236	67	125	186
244	72	130	191	249	80	138	199	257	89
147	208	266	98	156	217	275	60	118	179
237	68	126	187	245	73	131	192	250	81
139	200	258	90	148	209	267	99	157	218
276	61	119	180	238	69	127	188	246	74
132	193	251	82	140	201	259	91	149	210
268	100	158	219	277					

Table B.5: Ordering of the speech encoder bits for the 15.85 kbit/s mode: *table<sub>4(j)</sub>*

0	4	6	109	175	244	310	7	5	3
47	48	49	50	51	182	183	184	185	186
110	176	245	311	115	181	250	316	112	178
247	313	113	179	248	314	116	251	114	180
249	315	111	177	246	312	52	2	1	117
252	187	19	21	12	17	18	20	16	25
13	10	14	24	23	22	26	8	15	53
188	31	118	253	9	33	11	119	254	54
189	28	27	120	255	34	35	29	46	32
30	55	190	37	36	39	38	40	121	256
41	42	43	44	45	56	122	191	257	63
129	198	264	76	142	211	277	89	155	224
290	102	168	237	303	57	123	192	258	70
136	205	271	83	149	218	284	96	162	231
297	62	128	197	263	75	141	210	276	88
154	223	289	101	167	236	302	58	124	193
259	71	137	206	272	84	150	219	285	97
163	232	298	59	125	194	260	64	130	199
265	67	133	202	268	72	138	207	273	77
143	212	278	80	146	215	281	85	151	220
286	90	156	225	291	93	159	228	294	98
164	233	299	103	169	238	304	106	172	241
307	60	126	195	261	65	131	200	266	68
134	203	269	73	139	208	274	78	144	213
279	81	147	216	282	86	152	221	287	91
157	226	292	94	160	229	295	99	165	234
300	104	170	239	305	107	173	242	308	61
127	196	262	66	132	201	267	69	135	204
270	74	140	209	275	79	145	214	280	82
148	217	283	87	153	222	288	92	158	227
293	95	161	230	296	100	166	235	301	105
171	240	306	108	174	243	309			

Table B.6: Ordering of the speech encoder bits for the 18.25 kbit/s mode:  $table_s(j)$ 

0	4	6	121	199	280	358	7	5	3
47	48	49	50	51	206	207	208	209	210
122	200	281	359	127	205	286	364	124	202
283	361	125	203	284	362	128	287	126	204
285	363	123	201	282	360	52	2	1	129
288	211	19	21	12	17	18	20	16	25
13	10	14	24	23	22	26	8	15	53
212	31	130	289	9	33	11	131	290	54
213	28	27	132	291	34	35	29	46	32
30	55	214	37	36	39	38	40	133	292
41	42	43	44	45	56	134	215	293	198
299	136	120	138	60	279	58	62	357	139
140	295	156	57	219	297	63	217	137	170
300	222	64	106	61	78	294	92	142	141
135	221	296	301	343	59	298	184	329	315
220	216	265	251	218	237	352	223	157	86
171	87	164	351	111	302	65	178	115	323
72	192	101	179	93	73	193	151	337	309
143	274	69	324	165	150	97	338	110	310
330	273	68	107	175	245	114	79	113	189
246	259	174	71	185	96	344	100	322	83
334	316	333	252	161	348	147	82	269	232
260	308	353	347	163	231	306	320	188	270
146	177	266	350	256	85	149	116	191	160
238	258	336	305	255	88	224	99	339	230
228	227	272	242	241	319	233	311	102	74
180	275	66	194	152	325	172	247	244	261
117	158	166	354	75	144	108	312	94	186
303	80	234	89	195	112	340	181	345	317
326	276	239	167	118	313	70	355	327	253
190	176	271	104	98	153	103	90	76	267
277	248	225	262	182	84	154	235	335	168
331	196	341	249	162	307	148	349	263	321
257	243	229	356	159	119	67	187	173	145
240	77	304	332	314	342	109	254	81	278
105	91	346	318	183	250	197	328	95	155
169	268	226	236	264					

Table B.7: Ordering of the speech encoder bits for the 19.85 kbit/s mode:  $table_6(j)$ 

0	4	6	129	215	304	390	7	5	3
47	48	49	50	51	222	223	224	225	226
130	216	305	391	135	221	310	396	132	218
307	393	133	219	308	394	136	311	134	220
309	395	131	217	306	392	52	2	1	137
312	227	19	21	12	17	18	20	16	25
13	10	14	24	23	22	26	8	15	53
228	31	138	313	9	33	11	139	314	54
229	28	27	140	315	34	35	29	46	32
30	55	230	37	36	39	38	40	141	316
41	42	43	44	45	56	142	231	317	63
73	92	340	82	324	149	353	159	334	165
338	178	163	254	77	168	257	153	343	57
248	238	79	252	166	67	80	201	101	267
143	164	341	255	339	187	376	318	78	328
362	115	232	242	253	290	276	62	58	158
68	93	179	319	148	169	154	72	385	329
333	344	102	83	144	233	323	124	243	192
354	237	64	247	202	209	150	116	335	268
239	299	188	196	298	94	195	258	123	363
384	109	325	371	170	370	84	110	295	180
74	210	191	106	291	205	367	381	377	206
355	122	119	120	383	160	105	108	277	380
294	284	285	345	208	269	249	366	386	300
297	259	125	369	197	97	194	286	211	281
280	183	372	87	155	283	59	348	327	184
76	111	330	203	349	69	98	152	145	189
66	320	337	173	358	251	198	174	263	262
126	241	193	88	388	117	95	387	112	359
287	244	103	272	301	171	162	234	273	127
373	181	292	85	378	302	121	107	364	346
356	212	278	213	65	382	288	207	113	175
99	296	374	368	199	260	185	336	331	161
270	264	250	240	75	350	151	60	89	321
156	274	360	326	70	282	167	146	352	81
91	389	266	245	177	235	190	256	204	342
128	118	303	104	379	182	114	375	200	96
293	172	214	365	279	86	289	351	347	357
261	186	176	271	90	100	147	322	275	361
71	332	61	265	157	246	236			

Table B.8: Ordering of the speech encoder bits for the 23.05 kbit/s mode:  $table_{7(j)}$ 

0	4	6	145	247	352	454	7	5	3
47	48	49	50	51	254	255	256	257	258
146	248	353	455	151	253	358	460	148	250
355	457	149	251	356	458	152	359	150	252
357	459	147	249	354	456	52	2	1	153
360	259	19	21	12	17	18	20	16	25
13	10	14	24	23	22	26	8	15	53
260	31	154	361	9	33	11	155	362	54
261	28	27	156	363	34	35	29	46	32
30	55	262	37	36	39	38	40	157	364
41	42	43	44	45	56	158	263	365	181
192	170	79	57	399	90	159	297	377	366
275	68	183	388	286	194	299	92	70	182
401	172	59	91	58	400	368	161	81	160
264	171	80	389	390	378	379	193	298	69
266	265	367	277	288	276	287	184	60	195
82	93	71	369	402	173	162	444	300	391
98	76	278	61	267	374	135	411	167	102
380	200	87	178	65	94	204	124	72	342
189	305	381	396	433	301	226	407	289	237
113	215	185	128	309	403	116	320	196	331
370	422	174	64	392	83	425	219	134	188
432	112	427	139	279	163	436	208	447	218
236	229	97	294	385	230	166	268	177	443
225	426	101	272	138	127	290	117	347	199
414	95	140	240	410	395	209	129	283	346
105	241	437	86	308	448	203	345	186	107
220	415	334	319	106	313	118	123	73	207
421	214	384	373	438	62	371	341	75	449
168	323	164	242	416	324	304	197	335	404
271	63	191	325	96	169	231	280	312	187
406	84	201	100	67	382	175	336	202	330
269	393	376	383	293	307	409	179	285	314
302	372	398	190	180	89	99	103	232	78
88	77	136	387	165	198	394	125	176	428
74	375	238	227	66	273	282	141	306	412
114	85	130	348	119	291	296	386	233	397
303	405	284	445	423	221	210	205	450	108
274	434	216	343	337	142	243	321	408	451
310	292	120	109	281	439	270	429	332	295
418	211	315	222	326	131	430	244	327	349
417	316	143	338	440	234	110	212	452	245
121	419	350	223	132	441	328	413	317	339
126	104	137	446	344	239	435	115	333	206
322	217	228	424	453	311	351	111	442	224
213	122	431	340	235	246	133	144	420	329
318									

Table B.9: Ordering of the speech encoder bits for the 23.85 kbit/s mode:  $table_8(j)$ 

0	4	6	145	251	360	466	7	5	3
47	48	49	50	51	262	263	264	265	266
146	252	361	467	151	257	366	472	148	254
363	469	149	255	364	470	156	371	150	256
365	471	147	253	362	468	52	2	1	157
372	267	19	21	12	17	18	20	16	25
13	10	14	24	23	22	26	8	15	53
268	31	152	153	154	155	258	259	260	261
367	368	369	370	473	474	475	476	158	373
9	33	11	159	374	54	269	28	27	160
375	34	35	29	46	32	30	55	270	37
36	39	38	40	161	376	41	42	43	44
45	56	162	271	377	185	196	174	79	57
411	90	163	305	389	378	283	68	187	400
294	198	307	92	70	186	413	176	59	91
58	412	380	165	81	164	272	175	80	401
402	390	391	197	306	69	274	273	379	285
296	284	295	188	60	199	82	93	71	381
414	177	166	456	308	403	98	76	286	61
275	386	135	423	171	102	392	204	87	182
65	94	208	124	72	350	193	313	393	408
445	309	230	419	297	241	113	219	189	128
317	415	116	328	200	339	382	434	178	64
404	83	437	223	134	192	444	112	439	139
287	167	448	212	459	222	240	233	97	302
397	234	170	276	181	455	229	438	101	280
138	127	298	117	355	203	426	95	140	244
422	407	213	129	291	354	105	245	449	86
316	460	207	353	190	107	224	427	342	327
106	321	118	123	73	211	433	218	396	385
450	62	383	349	75	461	172	331	168	246
428	332	312	201	343	416	279	63	195	333
96	173	235	288	320	191	418	84	205	100
67	394	179	344	206	338	277	405	388	395
301	315	421	183	293	322	310	384	410	194
184	89	99	103	236	78	88	77	136	399
169	202	406	125	180	440	74	387	242	231
66	281	290	141	314	424	114	85	130	356
119	299	304	398	237	409	311	417	292	457
435	225	214	209	462	108	282	446	220	351
345	142	247	329	420	463	318	300	120	109
289	451	278	441	340	303	430	215	323	226
334	131	442	248	335	357	429	324	143	346
452	238	110	216	464	249	121	431	358	227
132	453	336	425	325	347	126	104	137	458
352	243	447	115	341	210	330	221	232	436
465	319	359	111	454	228	217	122	443	348
239	250	133	144	432	337	326			

---

## Annex C (informative): Change history

Change history							
Date	TSG #	TSG Doc.	CR	Rev	Subject/Comment	Old	New