

Source: SA5 (Telecom Management)
Title: 32.015 CR, "Draft update of document for 3G Publication" (S5-000306)
Document for: Approval
Agenda Item: 6.5.3

Spec	CR	Phas	Subject	Ca	Versi	Versi	Doc-2nd-
32.015	006	R99	Draft update of document for 3G Publication	F	3.1.1	3.2.0	S5-000306

CHANGE REQUEST

Please see embedded help file at the bottom of this page for instructions on how to fill in this form correctly.

32.015 CR 006

Current Version: **V.3.1.1**

GSM (AA.BB) or 3G (AA.BBB) specification number ↑

↑ CR number as allocated by MCC support team

For submission to: **SA#6**
list expected approval meeting # here ↑

for approval
for information

strategic
non-strategic *(for SMG use only)*

Form: CR cover sheet, version 2 for 3GPP and SMG The latest version of this form is available from: ftp://ftp.3gpp.org/Information/CR-Form-v2.doc

Proposed change affects:

(at least one should be marked with an X)

(U)SIM ME UTRAN / Radio Core Network

Source:

SA5#12

Date:

9 June 2000

Subject:

Draft update of document for 3G Publication

Work item:

Category:

(only one category shall be marked with an X)

F Correction
A Corresponds to a correction in an earlier release
B Addition of feature
C Functional modification of feature
D Editorial modification

Release:

Phase 2	<input type="checkbox"/>
Release 96	<input type="checkbox"/>
Release 97	<input type="checkbox"/>
Release 98	<input type="checkbox"/>
Release 99	<input checked="" type="checkbox"/>
Release 00	<input type="checkbox"/>

Reason for change:

With the move to 3G, the document needed to be corrected by removing the unnecessary features not supported by GPRS or 3G; i.e X.25 and Anonymous Access. While introducing the functionality introduced by 3G UMTS. New Architecture, Interfaces and_QoS.

Clauses affected:

Complete Document

Other specs affected:

Other 3G core specifications	<input type="checkbox"/>	→ List of CRs:	
Other GSM core specifications	<input type="checkbox"/>	→ List of CRs:	
MS test specifications	<input type="checkbox"/>	→ List of CRs:	
BSS test specifications	<input type="checkbox"/>	→ List of CRs:	
O&M specifications	<input type="checkbox"/>	→ List of CRs:	

Other comments:

3G TS 32.015 V3.1.1 (2000-04)

Technical Specification



3rd Generation Partnership Project; Technical Specification Group Services and System Aspects; GSM call and event data for the packet switched domain (Release 1999)

The present document has been developed within the 3rd Generation Partnership Project (3GPP™) and may be further elaborated for the purposes of 3GPP. The present document has not been subject to any approval process by the 3GPP Organisational Partners and shall not be implemented. This Specification is provided for future development work within 3GPP only. The Organisational Partners accept no liability for any use of this Specification. Specifications and reports for implementation of the 3GPP™ system should be obtained via the 3GPP Organisational Partners' Publications Offices.

Keywords

3GPP

Postal address

3GPP support office address

650 Route des Lucioles - Sophia Antipolis
Valbonne - FRANCE
Tel.: +33 4 92 94 42 00 Fax: +33 4 93 65 47 16

Internet

<http://www.3gpp.org>

Copyright Notification

No part may be reproduced except as authorized by written permission.
The copyright and the foregoing restriction extend to reproduction in all media.

© 2000, 3GPP Organizational Partners (ARIB, CWTS, ETSI, T1, TTA, TTC).
All rights reserved.

Contents

Foreword.....	7
1 Scope.....	8
2 References.....	8
3 Definitions, abbreviations and symbols.....	10
3.1 Definitions.....	10
3.2 Abbreviations.....	10
3.3 Symbols.....	11
4 Architecture.....	13
4.1 Charging Gateway Functionality.....	15
5 Charging Principles.....	17
5.1 Requirements.....	17
5.2 Charging Information.....	17
5.3 Charging Data Collection Principles.....	18
5.4 Generation of Charging ID.....	19
5.5 Charging for SMS in GPRS.....	19
5.6 Charging for Anonymous Access.....	20
5.7 Charging Triggers – CDR Generation.....	20
5.7.1 Triggers for S-CDR Charging Information Collection.....	20
5.7.1.1 Triggers for S-CDR Charging Information Addition.....	20
5.7.1.2 Triggers for S-CDR Closure.....	20
5.7.2 Triggers for M-CDR Charging Information Collection.....	21
5.7.2.1 Triggers for M-CDR Charging Information Addition.....	21
5.7.2.2 Triggers for M-CDR Closure.....	21
5.7.3 Triggers for G-CDR Charging Information Collection.....	22
5.8 Example charging scenarios.....	22
5.8.1 GPRS Mobile to PDN Context.....	22
5.8.2 GPRS Mobile to Mobile Context.....	23
5.8.3 PDN to GPRS Mobile Context.....	24
5.8.4 GPRS Mobile to PDN Context while roaming, GGSN in HPLMN.....	25
6 Charging Data Collection.....	25
6.1 Record contents.....	25
6.1.1 GPRS charging data in SGSN (S-CDR).....	27
6.1.2 GPRS charging data in GGSN (G-CDR).....	28
6.1.3 GPRS mobile station mobility management data in SGSN (M-CDR).....	29
6.1.4 GPRS MO SMS data in SGSN (S-SMO-CDR).....	30
6.1.5 GPRS MT SMS data in SGSN (S-SMT-CDR).....	31
6.1.6 Description of Record Fields.....	31
6.1.6.1 Access Point Name.....	31
6.1.6.2 Cause for Record Closing.....	31
6.1.6.3 Charging ID.....	32
6.1.6.4 Diagnostics.....	32
6.1.6.5 Duration.....	32
6.1.6.6 Dynamic Address Flag.....	33
6.1.6.7 Event Time Stamps.....	33
6.1.6.8 GGSN Address/GGSN Address Used.....	33
6.1.6.9 List of Traffic Data Volumes.....	33
6.1.6.10 Local Record Sequence Number.....	34
6.1.6.11 Message reference.....	34
6.1.6.12 MS Network Capability.....	34
6.1.6.13 Network Initiated PDP Context.....	34
6.1.6.14 Node ID.....	35
6.1.6.15 PDP Type.....	35

6.1.6.16	QoS Requested/QoS Negotiated	35
6.1.6.17	Record Extensions.....	35
6.1.6.18	Record Opening Time	35
6.1.6.19	Record Sequence Number	35
6.1.6.20	Record Type.....	35
6.1.6.21	Recording Entity Number.....	35
6.1.6.22	Remote PDP Address.....	35
6.1.6.23	Routing Area Code/Cell Identity/Change of location.....	36
6.1.6.24	Served IMEI.....	36
6.1.6.25	Served IMSI.....	36
6.1.6.26	Served MSISDN.....	36
6.1.6.27	Served PDP Address	36
6.1.6.28	Service Centre Address	36
6.1.6.29	SGSN Address	36
6.1.6.30	SGSN Change	36
6.1.6.31	Short Message Service Result	37
6.1.6.32	APN Selection Mode.....	37
6.1.6.33	Charging Characteristics	37
7	Charging Protocols	37
7.1	GPRS CDR Collection by GTP' Protocol.....	37
7.1.1	SGSN - CGF communication.....	38
7.1.2	GGSN - CGF communication.....	38
7.1.3	CGF - CGF communication	39
7.1.4	Port usage	39
7.1.4.1	UDP as the Path Protocol	39
7.1.4.2	TCP as Path Protocol.....	40
7.1.4.3	Network layer and lower layers	40
7.1.5	Charging related requirements for GPRS nodes	40
7.2	The GTP' charging protocol	40
7.2.1	Usage of GTP Header in charging	40
7.2.2	Information elements	41
7.3	GTP' Message Types	41
7.3.1	List of all GTP' message types.....	41
7.3.2	Reused GTP message types	43
7.3.3	GTP message type modifications implied by GTP'.....	44
7.3.4	GTP' message types.....	44
7.3.4.1	Node Alive Request.....	44
7.3.4.2	Node Alive Response.....	44
7.3.4.3	Redirection Request.....	45
7.3.4.4	Redirection Response	46
7.3.4.5	Data Record Transfer Request.....	46
7.3.4.5.1	General logic	46
7.3.4.5.2	Information Elements in Data Record Transfer Request.....	48
7.3.4.5.3	Packet Transfer Command IE	48
7.3.4.5.4	Data Record Packet IE	49
7.3.4.5.5	Sequence Numbers of Released Packets IE	50
7.3.4.5.6	Sequence Numbers of Cancelled Packets IE.....	50
7.3.4.5.7	Private Extension IE.....	51
7.3.4.6	Data Record Transfer Response.....	51
7.3.4.7	Examples of GTP' messaging cases.....	52
7.3.4.7.1	Case 1: The normal CDR packet transfer.....	53
7.3.4.7.2	Case 2: The GSN-CGF1 connection breaks before a successful CDR reception.....	53
7.3.4.7.3	Case 3: The GSN-CGF1 connection breaks after a successful CDR reception.....	56
7.4	Data Record Formats used in GTP'	57
7.4.1	ASN.1 format.....	57
7.4.2	Other formats	57
7.5	CGF - BS Protocol Interface	58
7.5.1	The transfer protocols at CGF - BS interface.....	58
7.5.2	The format of the CDRs at CGF - BS interface	58

8 Charging Data Record Structure..... 58

8.1 ASN.1 definitions for CDR information..... 58

Annex A (informative): Change history..... 67

Foreword

This Technical Specification (TS) has been produced by the 3rd Generation Partnership Project (3GPP).

The contents of the present document are subject to continuing work within the TSG and may change following formal TSG approval. Should the TSG modify the contents of the present document, it will be re-released by the TSG with an identifying change of release date and an increase in version number as follows:

Version x.y.z

where:

- x the first digit:
 - 1 presented to TSG for information;
 - 2 presented to TSG for approval;
 - 3 or greater indicates TSG approved document under change control.
- y the second digit is incremented for all changes of substance, i.e. technical enhancements, corrections, updates, etc.
- z the third digit is incremented when editorial only changes have been incorporated in the document.

1 Scope

The GSM and UMTS PLMN supports a wide range of ~~voice and non-voice~~ packet based services in the same network. In order to enable operators the ability to provide a commercially viable service there is a need to provide charging functions. The present document describes the functionality of charging, which includes the General Packet Radio Service (GPRS) in GSM and UMTS. ~~PRS needed to support the first phase of GPRS~~, as defined in TS 22.060 [3] and TS 23.060 [8] (packet based services).

2 References

The following documents contain provisions, which through reference in this text, constitute provisions of the present document.

- References are either specific (identified by date of publication, edition number, version number, etc.) or non-specific.
- For a specific reference, subsequent revisions do not apply.
- For a non-specific reference, the latest version applies.

- [1] 3G TS 21.905: "3G vocabulary".
- [2] void GSM 04.08: "Digital cellular telecommunications system (Phase 2+); Mobile radio interface layer 3 specification".
- [3] 3G TS 22.060: "General Packet Radio Service (GPRS); Service description; Stage 1".
- [4] 3G TS 23.003: "Numbering, addressing and identification".
- [5] void
- [6] void
- [7] 3G TS 23.040: "Technical realization of the Short Message Service (SMS); Point-to-Point (PP)".
- [8] 3G TS 23.060: "General Packet Radio Service (GPRS); Service description; Stage 2".
- [9] void
- [10] void
- [11] void
- [12] void
- [13] 3G TS 24.008: "Digital cellular telecommunications system (Phase 2+); Mobile radio interface layer 3 specification".
- [14] ~~void~~ 3G TS 25.401: "UTRAN Overall Description".
- [15] void
- [16] void
- [17] void
- [18] void
- [19] void
- [20] void

- [21] 3G TS 29.002: "Mobile Application Part (MAP) specification".
- [22] 3G TS 29.060: "General Packet Radio Service (GPRS); GPRS Tunnelling Protocol (GTP) across the Gn and Gp Interface".
- [23] ~~void~~ 3G TS 32.005 "GSM call and event data for the circuit switched domain".
- [24] CCITT Recommendations I.130: "General modelling methods – Method for the characterisation of telecommunication services supported by an ISDN and network capabilities of an ISDN".
- [25] CCITT Recommendation E.164: "Numbering plan for the ISDN era".
- [26] CCITT Recommendation Q.65: "Methodology – Stage 2 of the method for the characterization of services supported by an ISDN".
- [27] CCITT Recommendation Q.922: "Digital subscriber signalling system no. 1 (DSS 1) – Data link layer – ISDN data link layer specification for frame mode bearer services".
- [28] CCITT Recommendation Q.933: "Digital subscriber signalling system no. 1 (DSS 1) – Network layer – Signalling specification for frame mode basic call control".
- [29] CCITT Recommendation V.42 bis: "Data communication over the telephone network – Data compression procedures for data circuit-terminating equipment (DCE) using error correction procedures".
- [30] ~~CCITT Recommendation X.3: "Packet assembly disassembly facility (PAD) in a public data network".~~Void
- [31] ~~CCITT Recommendation X.25: "Interface between data terminal equipment (DTE) and data circuit terminating equipment (DCE) for terminals operating in the packet mode and connected to public data networks by dedicated circuit".~~Void
- [32] ~~CCITT Recommendation X.28: "DTE / DCE interface for a start stop mode data terminal equipment accessing the packet assembly / disassembly facility (PAD) in a public data network situated in the same country".~~Void
- [33] ~~CCITT Recommendation X.29: "Procedures for the exchange of control information and user data between a packet assembly / disassembly (PAD) facility and a packet mode DTE or another PAD".~~Void
- [34] ~~CCITT Recommendation X.75: "Packet switched signalling system between public networks providing data transmission services".~~Void
- [35] ~~CCITT Recommendation X.121: "International Numbering Plan for Public Data Networks".~~Void
- [36] IETF RFC 768 (1980): "User Datagram Protocol" (STD 6).
- [37] IETF RFC 791 (1981): "Internet Protocol" (STD 5).
- [38] IETF RFC 792 (1981): "Internet Control Message Protocol" (STD 5).
- [39] IETF RFC 793 (1981): "Transmission Control Protocol" (STD 7).
- [40] ISO8824 (90) / X.208 (88): "Information technology - open System Interconnection - Specification of Abstract Syntax Notation One (ASN.1)".
- [41] ISO8824-1 (94) / X.680 (94): "Information technology - Abstract Syntax Notation One (ASN.1) - Specification of Basic Notation".

3 Definitions, abbreviations and symbols

3.1 Definitions

Refer to: TS 22.060 [3].

~~In GSM 02.02 the bearer services are described. The general network configuration is described in GSM 03.02 and the GSM PLMN access reference configuration is defined in GSM 04.02. The various connection types used in the GSM PLMN are presented in GSM 03.10. Terminology used in the present document is presented in TS 21.905 [1]. For support of data services between GSM PLMN and other networks see GSM 09-series of Specifications.~~

For the purposes of the present document the following definitions apply. Additional applicable definitions can be found in 3G TS 22.060 [3] and 3G TS 25.401 [14].

GPRS: Packet Services for GSM and UMTS systems.

(GSM only): indicates that this section or paragraph applies only to a GSM system. For multi-system cases this is determined by the current serving radio access network.

(UMTS only): indicates that this section or paragraph applies only to a UMTS system. For multi-system cases this is determined by the current serving radio access network.

In GSM,....: indicates that this paragraph applies only to GSM System. For multi system cases this is determined by the current serving radio access network.

In UMTS,....: indicates that this paragraph applies only to UMTS System. For multi system cases this is determined by the current serving radio access network.

inter-system change: a change of radio access between different radio access technologies such as GSM and UMTS.

MS: this specification makes no distinction between MS and UE.

2G- / 3G- : The prefixes 2G- and 3G- refers to functionality that supports only GSM or UMTS, respectively, e.g., 2G-SGSN refers only to the GSM functionality of an SGSN. When the prefix is omitted, reference is made independently from the GSM or UMTS functionality.

3.2 Abbreviations

For the purposes of the present document the following abbreviations apply. Additional applicable abbreviations can be found in TS 21.905 [1].

APN	Access Point Name
BG	Border Gateway
BS	Billing System
BSS	Base Station Subsystem
CDR	Call Detail Record
C-ID	Charging ID
CG	Charging Gateway
CGF	Charging Gateway Functionality
GTP	GPRS Tunnel Protocol
CMIP	Common Management Information Protocol
F/W	Firewall
GGSN	Gateway GPRS Support Node
GPRS	General Packet Radio Service
G-CDR	Gateway GPRS Support Node – Call Detail Record
IHOSS:OSP	Internet Hosted Octet Stream Service:Octect Stream Protocol
IP	Internet Protocol
IPv4	Internet Protocol version 4

IPv6	Internet Protocol version 6
MS	Mobile Station
M-CDR	Mobility Management - Call Detail Record
NE	Network Element
NSS	Network and Switching Subsystem
NMG	Network Management Gateway
NMN	Network Management Node
OMC	Operations and Maintenance Centre
OSF	Operations System Function
OSP	Octet Stream Protocol
PDN	Packet Data Network
PDP	Packet Data Protocol, e.g., IP or X.25
PLMN	Public Land Mobile Network
PPP	Point to Point Protocol
PSPDN	Packet Switched Public Data Network
PTM M	Point to Multipoint Multicast
PTM G	Point to Multipoint Group Call
PTM SC	Point to Multipoint Service Centre
RAC	Routing Area Code
SGSN	Serving GPRS Support Node
SNDCP	Sub-Network Dependent Convergence Protocol
SNMP	Simple Network Management Protocol
SS7	Signalling System No. 7
S-CDR	Serving GPRS Support Node – Call Detail Record
S-SMO-CDR	SGSN delivered Short message Mobile Originated – Call Detail Record
S-SMT-CDR	SGSN delivered Short message Mobile Terminated – Call Detail Record
TID	Tunnel Identifier
<u>URA</u>	<u>UTRAN Registration Area</u>
<u>USIM</u>	<u>User Service Identity Module</u>
<u>UTRAN</u>	<u>UMTS Terrestrial Radio Access Network</u>

3.3 Symbols

For the purposes of the present document the following symbols apply:

A	Interface between an MSC and a BSC.
Ga	Charging data collection interface between a CDR transmitting unit (e.g. GGSN or SGSN) and a CDR receiving functionality (CGF).
Gb	Interface between an SGSN and a BSC.
Gc	Interface between an GGSN and an HLR.
Gd	Interface between an SMS-GMSC and an SGSN, and between a SMS-IWMSC and an SGSN.
Gf	Interface between an SGSN and an EIR.
Gi	Reference point between GPRS and an external packet data network.
Gn	Interface between two GSNs within the same PLMN.
Gp	Interface between two GSNs in different PLMNs. The Gp interface allows support of GPRS network services across areas served by the co-operating GPRS PLMNs.
Gr	Interface between an SGSN and an HLR.
Gs	Interface between an SGSN and an MSC/VLR.
<u>Iu</u>	<u>Interface between the RNS and the core network. It is also considered as a reference point.</u>
kbit/s	Kilobits per second.

<u>Mbit/s</u>	<u>Megabits per second. 1 Mbit/s = 1 million bits per second.</u>
R	Reference point between a non-ISDN compatible TE and MT. Typically this reference point supports a standard serial interface.
<u>Reporting Area</u>	<u>The service area for which an MS's location shall be reported.</u>
<u>Service Area</u>	<u>The location accuracy level needed for service management purposes in the 3G-SGSN, e.g., a routing area or a cell. The 3G-SGSN can request the SRNC to report: i) the MS's current service area; ii) when the MS moves into a given service area; or iii) when the MS moves out of a given service area.</u>
Um	Interface between the mobile station (MS) and the GPRS fixed network part. The Um interface is the GPRS network interface for providing packet data services over the radio to the MS. The MT part of the MS is used to access the GPRS services through this interface. <u>Interface between the mobile station (MS) and the GSM fixed network part. The Um interface is the GSM network interface for providing GPRS services over the radio to the MS. The MT part of the MS is used to access the GPRS services in GSM through this interface.</u>
<u>Uu</u>	<u>Interface between the mobile station (MS) and the UMTS fixed network part. The Uu interface is the UMTS network interface for providing GPRS services over the radio to the MS. The MT part of the MS is used to access the GPRS services in UMTS through this interface.</u>

4 Architecture

The following Figures 1 and 2 show the GPRS Packet Domain logical architecture and GPRS Packet Domain charging logical architecture.

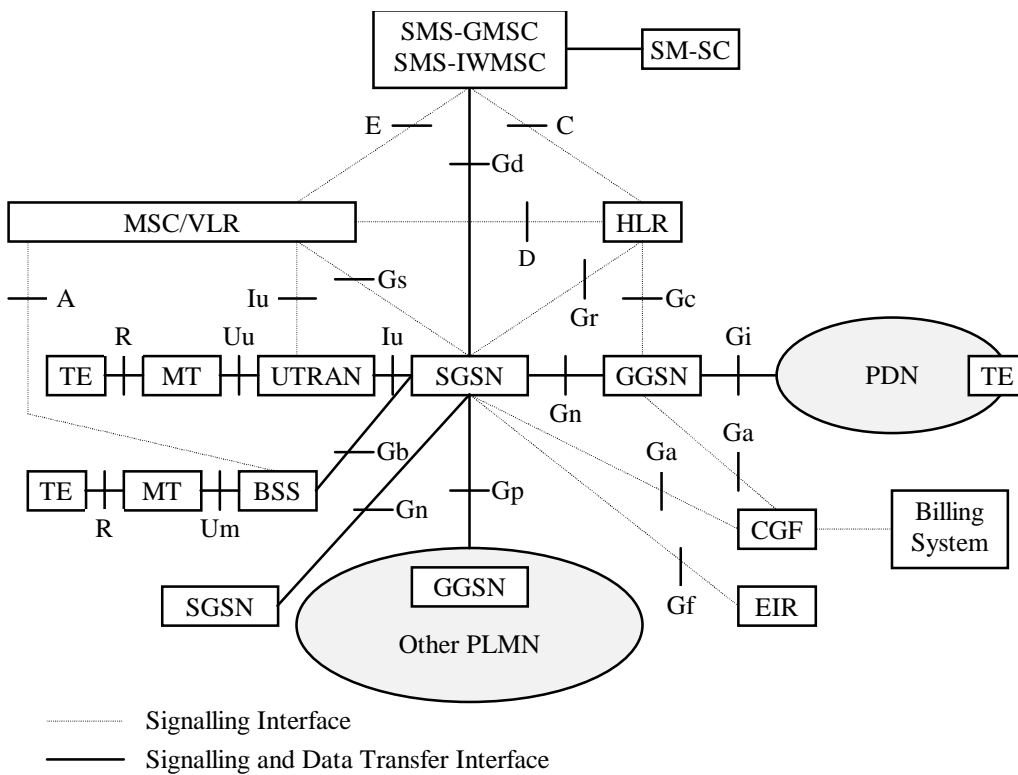
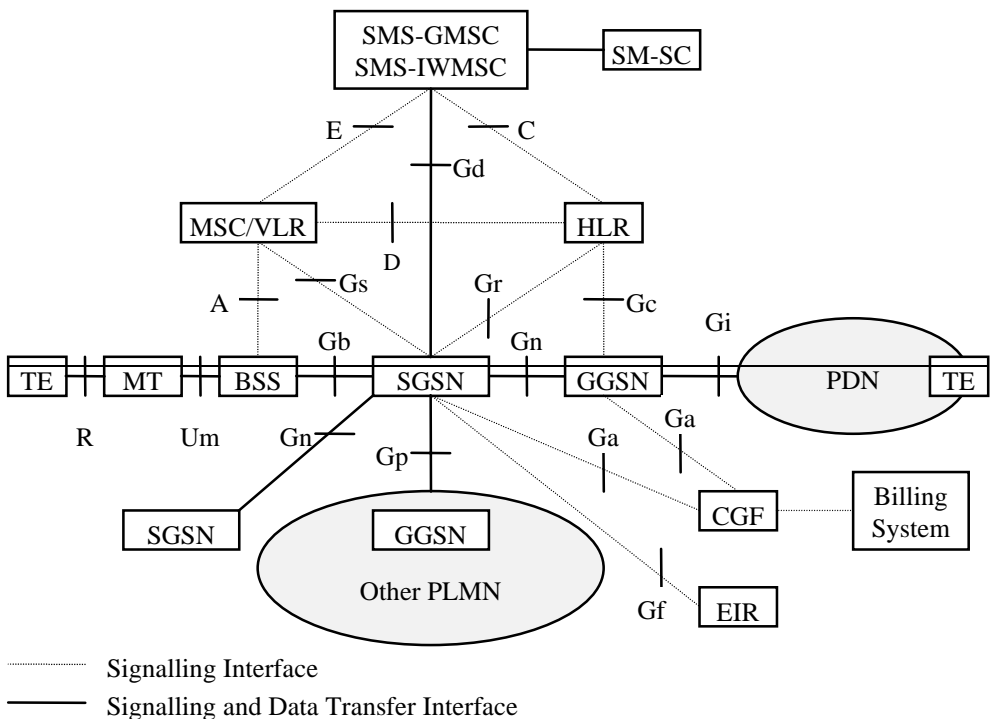
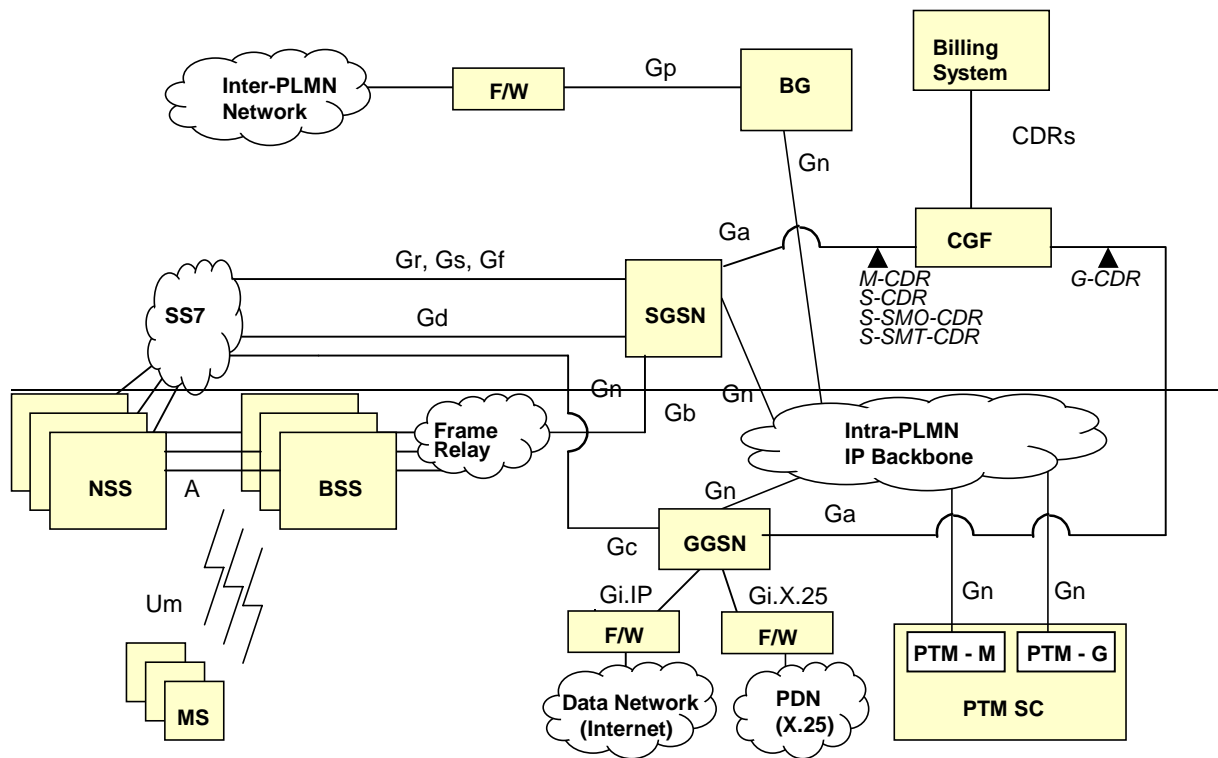

Figure 1: Overview of the GPRS Packet Domain Logical Architecture

GPRS is logically implemented on the GSM structure through the addition of two network nodes, the Serving GPRS Support Node and the Gateway GPRS Support Node. No inference should be drawn about the physical configuration on an interface from Figure 1.

The packet domain Core Network functionality is logically implemented on two network nodes, the Serving GPRS Support Node and the Gateway GPRS Support Node. No inference should be drawn about the physical configuration on an interface from Figure 1.



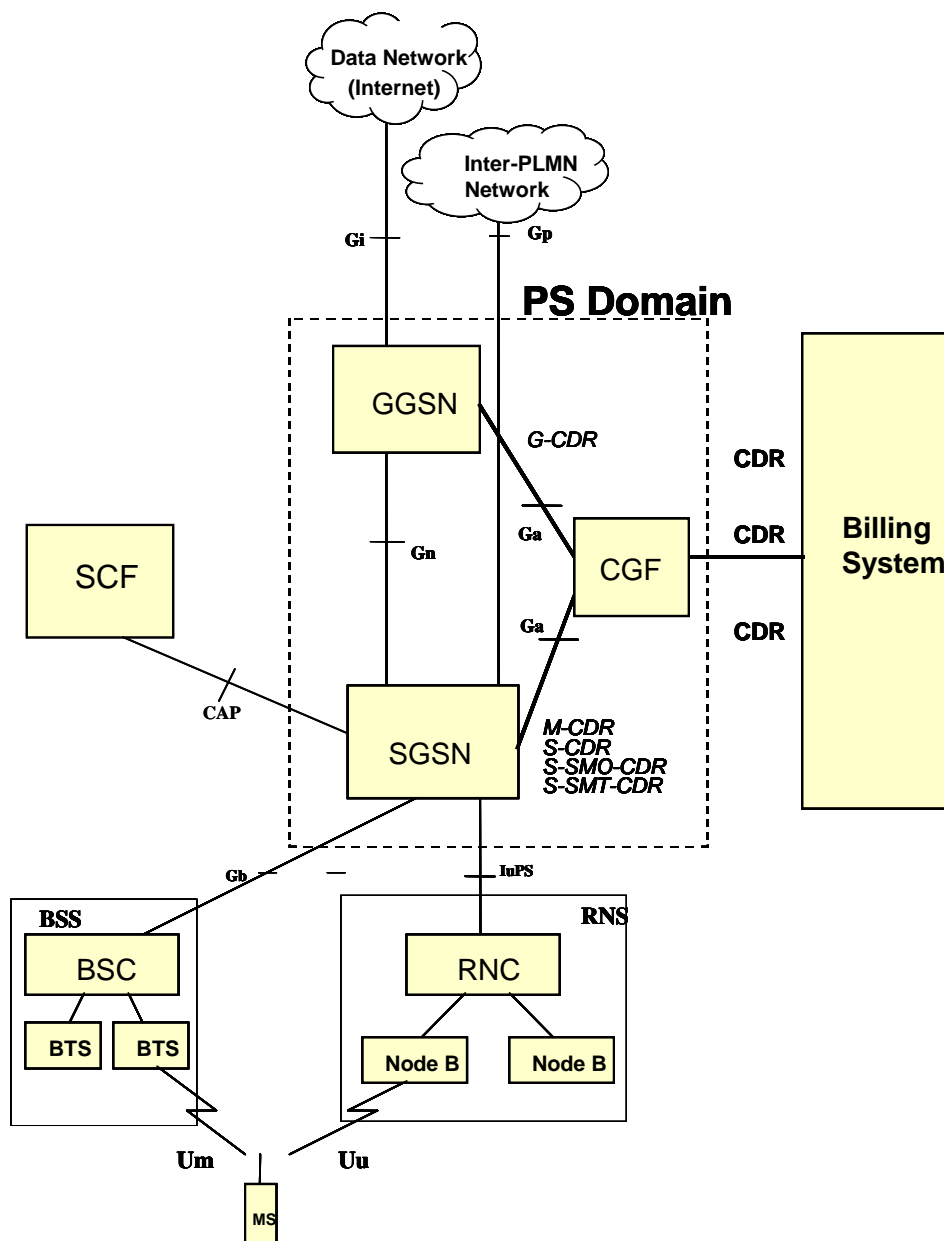

Figure 2: GPRS Packet Domain charging logical architecture

4.1 Charging Gateway Functionality

The Charging Gateway Functionality (CGF) provides a mechanism to transfer charging information from the SGSN and GGSN nodes to the network operator's chosen Billing Systems (BS). The Charging Gateway concept enables an operator to have just one logical interface between the CGF and the BS. The CGF may be supported in one of the following ways:

- as a centralised separate network element (Charging Gateway);
- as a distributed functionality resident in the SGSNs and GGSNs.

Support of the centralised or distributed CGF in a network is implementation dependent, and subject to vendor/manufacturer agreement. Regardless of the way in which the CGF is supported in the network, the functionality of the CGF is similar. Figure 3 gives an overview of the two basic configurations: In scenario 1, the GSNs support an external interface to the charging gateways they are connected to. In scenario 2, the GSNs support the charging gateway functionality internally.

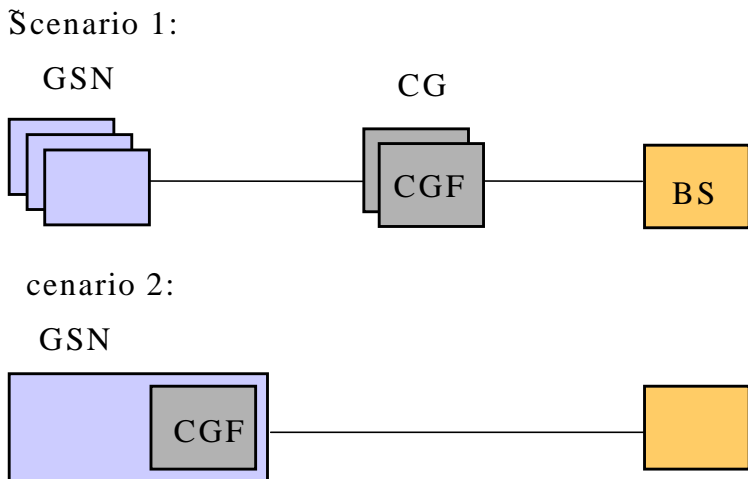

Figure 3: Basic architectural scenarios for the CGF location

If the GSNs with internal charging gateway functionality also support the external interface, additional configurations as shown in Figure 4 are possible. In scenario 3, the GSN with integrated charging gateway function also acts as CGF for other GSNs. In scenario 4, the GSN with integrated charging gateway function also supports the transmission of CDRs to external CGFs.

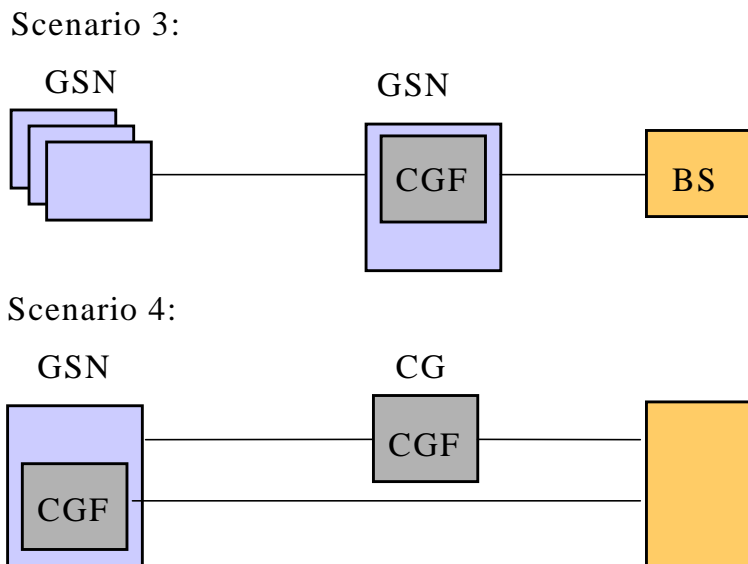

Figure 4: Optional scenarios for the CGF configuration

The above four scenarios are not exhaustive.

The CGF provides the mechanism to transfer charging information from the SGSN and GGSN nodes to the network operator's chosen Billing Systems(s) (BSs). The main functions of the CGF are:

- the collection of GPRS CDRs from the GPRS nodes generating CDRs;
- intermediate CDR storage buffering;
- the transfer of the CDR data to the billing systems.

The CGF acts as a storage buffer for real time CDR collection. It provides the CDR data to the billing system. This specification identifies the external interfaces of the CGF, but does not specify the internal functionality of the CGF. However, in order to assist in the understanding of the CGF, it may perform specific activities, such as consolidation of CDRs, pre-processing of CDR fields, filtering of un-required CDR fields, and adding of Operator defined fields for specific billing systems. These specific activities may be performed to optimise the charging information that is to be forwarded to the Billing System, which should reduce the load in the Billing System.

In addition to the centralised CGF it is possible to have the CGF distributed to the SGSNs and/or GGSNs.

The CGF can reside in a separate network element (Charging Gateway) or be integrated in the GSNs. It can receive CDR fields from the GSNs in real time mode. It should have enough storage to enable it to transmit the collected charging data to the Billing System in file mode.

The CGF may have to support several transmission protocols towards the Billing System, depending on the Billing System(s) used. One of the main purposes of the CG (or even just a CGF) is to reduce the number of different interfaces between the billing system (BS) and the GGSNs and SGSNs sending charging data. If a new BS is introduced it shall be interfaced to the CGF, i.e. the protocol stacks and configurations of the GSNs do not need to be updated. The usage and load of mass memory media can be more evenly distributed. The portion of the CGF embedded into a single physical device is called the Charging Gateway entity. The CGF may be distributed to several physical Charging Gateways or GSNs, to facilitate redundancy. If that Charging Gateway entity that is the Primary Charging Gateway entity, does not respond to communication originating from the GSNs, the GSNs will try to send the CDR data to a Secondary Charging Gateway entity. Here each GSN will have several IP addresses (of different priority) for the Charging Gateway entities, thus avoiding downtime of the CGF.

5 Charging Principles

5.1 Requirements

- ~~1) Based on the requirements in 22.115 here are the specific details relating to the packet domain. Every GPRS operator collects and processes their own charging information.~~
- ~~2) GPRS charging shall support anonymous access to the GPRS bearer service.~~
- ~~23) As much as is possible the GPRS charging functions should support open interfaces for possible use in future cellular digital packet based networks.~~
- ~~34) It shall be possible to provide reverse charging as a subscription option. However, reverse charging may not be applicable to certain external data network protocols.~~
- 145) Every PDP context shall be assigned a unique identity number for billing purposes. (i.e. the charging id).
- ~~256) Data volumes on both the uplink and downlink direction shall be counted separately. The data volumes shall reflect the user data application data as precisely as possible as delivered to and from by the user.~~
- 367) The charging mechanisms shall provide the duration of the PDP context with date and time information.
- ~~478) The GPRS operator may define a subset of the charging information specified by GPRS charging standards. This means that it shall be possible to configure the SGSN and GGSN for the CDR information generated.~~
- ~~589) The GSNs shall be capable of handling specific charging characteristics provided through the either HLR subscription data or default values..... This is to improve charging record generation efficiency determined by the operator, based on the configuration of CDR trigger parameters at the GSNs.~~

~~The SGSN and GGSN are not obliged to have non-volatile memory.~~

- ~~— This means that a GSN may lose its data when reset. The only permanent information that shall be stored in a GSN is the configuration data (e.g. cell/RA definition in SGSN).~~

5.2 Charging Information

Charging information in the GPRS network is collected for each MS by the SGSNs and GGSNs, which are serving that MS. The information that the operator uses to generate an invoice to the subscriber is operator-specific. Billing aspects, e.g., a regular fee for a fixed period, are outside the scope of this specification.

The SGSN collects charging information for each MS related with the radio network usage, while the GGSN collects charging information for each MS related with the external data network usage. Both GSNs also collect charging information on usage of the GPRS network resources.

~~PTP charging information is collected for the GPRS subscriber.~~

~~As a minimum, the SGSNs shall collect the following charging information:~~

- 1) usage of the radio interface: the charging information shall describe the amount of data transmitted in MO and MT directions categorised with QoS and user protocols;

~~Charging based on user protocols (PDP context type) for sent/received data volume forms the basis for volume charging. All changes in QoS are recorded separately. This provides post processing systems, if required, to sort out their charging relevance.~~

- 2) usage duration of the packet data protocol addresses: the charging information shall describe how long the MS has used the packet data protocol addresses;—

Duration of PDP context is counted as the time interval from PDP Context activation to PDP Context Deactivation.

- 3) usage of the general GPRS resources: the charging information shall describe the usage of other GPRS-related resources and the MSs GPRS network activity (e.g., mobility management).

- 4) ~~location of MS: HPLMN, VPLMN, plus optional higher accuracy location information;~~

~~— As a minimum, the GGSN shall collect the following charging information: destination and source: the charging information shall describe the destination and source addresses with a level of accuracy as defined by the GPRS operator;~~

- 45) Destination and source: the charging information shall describe provide the destination and actual source addresses used by the subscriber for the PDP context with a level of accuracy as defined by the GPRS Operator. The charging information shall describe the destination addresses with a level of accuracy as determined by the APN (Access Point Name).

~~Distinction of the data traffic to different source and destination or subnetworks may be performed by using the APN (Access Point Name).~~

- 56) usage of the external data networks: the charging information shall describe the amount of data sent and received to and from the external data network.

~~External networks can be identified by the APN (access point name). The volume counts can be charged by post-processing as configured.~~

- 7) ~~usage of the packet data protocol addresses: the charging information shall describe how long the MS has used the PDP addresses.~~

- 68) location of MS: HPLMN, VPLMN, plus optional higher-accuracy location information.

The highest accuracy location information available in GGSN is SGSN address.

5.3 Charging Data Collection Principles

Call data record generation and contents should be flexible and unnecessary redundancy in data should be avoided.

~~1. There are two main records types (one for the SGSN and one for the GGSN related to PDP contexts). Each PDP context generates its own record. A third record is provided for mobility management in the SGSN. The SGSN may also provide two SMS related records in case of short message delivery.~~

1. Each PDP context generates its own record types (the S-CDR for the SGSN and the G-CDR for the GGSN related to PDP contexts).
2. The SGSN can optionally provide a record for mobility management of the attached MS in the M-CDR.
3. The SGSN shall provide two SMS related records, in case of GPRS delivered MO short message S-SMO-CDR and MT short message S-SMT-CDR.
42. Optional basic MS Location information may shall be included in the SGSN PDP context records.

53. Records shall only include relevant information, i.e. traffic activity since last record.

The criteria for record generation is based on real time needs, information safety (backup) and some specific events, such as expiry of the partial record timer(s), transferred data volume limit(s), inter SGSN routing area update, inter/intra system handover.

64. Change of tariff period (if used) should not cause new CDRs to be sent to avoid peaks in data transfer. Instead such events should close the existing volume counters and open new ones when appropriate traffic is detected. This can be done by having a new record in the same message. It is up to the operator how often the CDRs are transferred from a GSN.

75. Both SGSN and GGSN nodes shall collect information from same chargeable sessions (PDP contexts). A unique reference (Charging ID ~~and in combination with~~ GGSN address) is needed to enable ~~connection~~ correlation between information from several records produced from same PDP context.

5.4 Generation of Charging ID

The concept of serving connections is different in the GSM switching network to that for the GPRS network. Therefore different mechanisms are needed to supply the billing system centres with charging information.

Circuit switched calls can be charged in one MSC (the anchor MSC) where all relevant data is available. That is guaranteed by routing all signalling information through the anchor MSC even if the traffic channel of a call is routed through another MSC due to handover.

In a GPRS network the complete PDP context handling can be switched over from an old SGSN to a new SGSN due to routing area updates with the consequence that charging records will be generated in more than one SGSN. Furthermore different data has to be collected in the SGSNs and GGSNs. So for one PDP context, charging records are needed from both the SGSN and GGSN.

The billing system shall be provided with all relevant information from the network to charge for that one activated PDP context.

During the active PDP context all records which belong to this context could normally be identified by the TID. However:

- an MS can activate and deactivate PDP contexts in a very short time interval, and these PDP contexts can have the same TID (only parallel established PDP contexts have different TIDs);
- different SGSNs can be involved in the same PDP context as described above;
- the timing clocks of the GSN elements may not be fully synchronised.

Therefore it is nearly impossible for a billing post-processing system to gather the records of one PDP context only by using the IMSI, NSAPI (TID) and time.

This is solved by assigning a unique Charging ID number (C-ID) to all records generated for that one PDP context.

The unique C-ID is generated in the GGSN when the PDP context is activated. A C-ID is generated for each activated context, so that each has a unique C-ID. The C-ID shall be transferred from the ~~G~~SGSN to the new another SGSN (~~following a in the routing area update response message~~). All PDP-CDRs for each activated PDP context generated by each SGSNs and GGSNs shall therefore contain the same unique combination of the C-ID and GGSN address, to permit subsequent Charging Gateway / Billing System correlation of the generated CDRs.

This combination of GGSN address together with the C-ID should be a unique identification over a long period of time in all GPRS networks.

5.5 Charging for SMS in GPRS

~~In GPRS the SMS transmission (MO or MT) can be done provided over GPRS via the SGSN.~~ The SGSN shall provide an S-SMO-CDR when short message is mobile originated and an S-SMT-CDR when it is mobile terminated. In addition, also SMS-IWMSC (MO-SMS) and SMS-GMSC (MT-SMS) may provide SMS related CDRs as described in ~~GSM 12.05~~ [13] TS 3G 32.005.

No active PDP context is required when sending or receiving short messages. If the subscriber has an active PDP context, volume counters of S-CDR are not updated due to short message delivery.

The contents of S-SMO and S-SMT CDRs are presented in tables 8 and 9.

~~5.6~~ Charging for Anonymous Access

~~S-CDRs and G-CDRs are generated by the SGSNs and GGSNs in the case of Anonymous Access, and separately identified in the CDRs.~~

~~The external Anonymous Access server is charged by the Operator based on the APN.~~

5.67 Charging Triggers – CDR Generation

~~The S-CDR, M-CDR, G-CDR, S-SMO-CDR, and S-SMT-CDR are generated by the SGSN and GGSN to collect charging information such that they may be subsequently transferred to the Charging Gateway Function.~~

The following sub-clauses describe the trigger conditions for collection of charging information and CDR generation by the SGSN/GGSN.

5.67.1 Triggers for S-CDR Charging Information Collection

An S-CDR is used to collect charging information related to the PDP context packet-data information for a GPRS mobile in the SGSN.

An S-CDR shall be opened for each activated PDP context, and record details such as Record Type, Served IMSI, Sequence Number etc. Not all of the charging information to be collected is static, and other charging information is directly dependent on dynamic GPRS usage. Subsequent partial records may be opened if the S-CDR is closed and the PDP context is still active.

The subsequent subclauses identify the conditions for adding information to, and closing of, the S-CDR for generation towards the CGF.

5.67.1.1 Triggers for S-CDR Charging Information Addition

The "List of Traffic Volumes" attribute of the S-CDR consists of a set of containers which are added when specific trigger conditions are met, and identify the volume count separated for uplink and downlink traffic on encountering that trigger condition.

Table 1: Triggers for S-CDR charging information addition

Trigger Conditions	Description/Behaviour
QoS Change	A change in the QoS shall result in a "List of Traffic Data Volumes" container being added to the CDR.
Tariff Time Change	On reaching the Tariff Time Change a "List of Traffic Data Volumes " container shall be added to the CDR.
CDR Closure	A list of "List of Traffic Data Volumes" container shall be added to the S-CDR.

5.67.1.2 Triggers for S-CDR Closure

The S-CDR shall be closed on encountering some trigger conditions. The following table identifies which conditions are supported to permit closures of the S-CDR.

Table 2: Triggers for S-CDR closure

Closure Conditions	Description/Behaviour
End of PDP Context within the SGSN	Deactivation of the PDP context in the SGSN shall result in the CDR being closed. The trigger condition covers:- <ul style="list-style-type: none"> - termination of PDP context, - SGSN change (inter-SGSN routing area update), - any abnormal release.
Partial Record Reason	O&M reasons permit the closure of the CDR for internal reasons. The trigger condition covers:- <ul style="list-style-type: none"> - data volume limit, - time (duration) limit, - maximum number of charging condition changes, - <u>management intervention,</u> - <u>Intra system handover (change of radio interface from GSM to 3G or visa versa).</u>

In the event that the S-CDR is closed and the PDP context remains active, a further S-CDR shall be opened with an incremented Sequence Number in the SGSN.

5.67.2 Triggers for M-CDR Charging Information Collection

An M-CDR is used to collect charging information related to the mobility management of a GPRS mobile in the SGSN.

An M-CDR shall be opened for each GPRS mobile upon GPRS Attach, and record details such as Record Type, Served IMSI, Sequence Number etc. Not all of the charging information to be collected is static, and other charging information is directly dependent on the GPRS-mobility of the MS as provided by the radio access network. Subsequent partial records may be opened if the M-CDR is closed and the MS is still attached to the network.

The subsequent subclauses identify the conditions for adding information to, and closing of, the M-CDR. for generation towards the CGF.

5.67.2.1 Triggers for M-CDR Charging Information Addition

The "Change of Location" attribute of the M-CDR consists of a set of containers, which are added when specific trigger conditions are met, and identify the time_stamped routing area on encountering that trigger condition.

Table 3: Triggers for M-CDR Charging Information Addition

Trigger Conditions	Description/Behaviour
Mobility Change	A change in the Routing Area shall result in a "Change of Location" container being added to the M-CDR.

5.67.2.2 Triggers for M-CDR Closure

The M-CDR shall be closed on encountering some trigger conditions. The following table identifies which conditions are supported to permit closures of the M-CDR.

Table 4: Triggers for M-CDR closure

Closure Conditions	Description/Behaviour
End of MM Context within SGSN	Deactivation of the MM context in the SGSN shall result in the CDR being closed. The trigger condition covers:- <ul style="list-style-type: none"> - SGSN change (inter-SGSN routing area update),

	<ul style="list-style-type: none"> - GPRS detach, - any abnormal release.
Partial Record Reason	<p>O&M reasons permit the closure of the CDR for internal reasons. The trigger condition covers:-</p> <ul style="list-style-type: none"> - time (duration) limit, - maximum number of mobility changes, and - <u>Management intervention.</u> <p>- <u>Intra system handover (change of radio interface from GSM to 3G or visa versa).</u></p>

In the event that the M-CDR is closed and the GPRS mobile is still known to the SGSN, a further logical M-CDR shall be opened with an incremented Sequence Number in the SGSN.

5.67.3 Triggers for G-CDR Charging Information Collection

A G-CDR is used to collect charging information related to the packet data information for a GPRS mobile in the GGSN.

A G-CDR shall be opened for each activated PDP context, and record details such as Record Type, Served IMSI, Sequence Number etc. Not all of the charging information to be collected is static, and other charging information is directly dependent on dynamic GPRS usage.

The "List of Traffic Data Volumes" attribute of the G-CDR consists of a set of containers which are added following specific trigger conditions, and identify the volume count on encountering that trigger condition. The trigger conditions are as for the S-CDR (see previous subclause on "Triggers for S-CDR Charging Information Collection") with exception that ~~the an~~ SGSN change of the same system type (GSM or 3G) does will not need to close the G-CDR. Subsequent partial records may be opened if the G-CDR is closed and the PDP context is still active.

In the event that the G-CDR is closed and the PDP context remains active, a further G-CDR is opened with an incremented Sequence Number in the GGSN.

5.78 Example charging scenarios

This subclause contains a number of example scenarios illustrating the purpose and practical usage of the various types of records defined in the previous subclauses. These examples are by no means exhaustive.

For the purpose of these examples the following assumptions have been made:

- the CDR records are sent to a CGF;
- the generation of all of the CDR record types has been enabled.

The following conventions have been used for the Figures contained within this subclause:

- 1) Network connections and signalling transactions are illustrated by means of solid lines and referenced by number e.g. (1).
- 2) Operation & Maintenance actions, such as the transfer of call records, are represented by means of dotted lines and referenced by letter e.g. (A).

5.78.1 GPRS Mobile to PDN Context

Figure 5 illustrates a simple outgoing GPRS context from a PLMN GPRS subscriber "A" to a mainframe "B" via a PDN (1).

The respective PDP context is activated in the SGSN and GGSN and PDP PDUs are routed in MO and MT direction. The SGSN shall create a S-CDR and the GGSN shall create a G-CDR for subscriber "A".

The records generated are subsequently transferred to the CGF (A). The CGF transfers the CDRs to the BS.

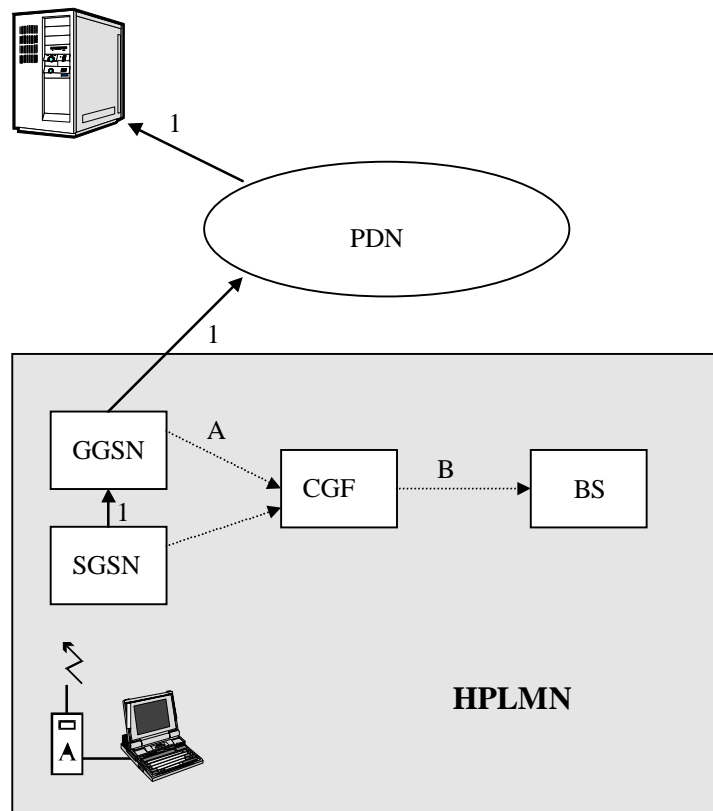

Figure 5: GPRS Mobile to PDN Context

5.7.8.2 GPRS Mobile to Mobile Context

Figure 6 illustrates a simple GPRS mobile to mobile context within the same HPLMN.

The respective A-party related PDP context is activated in the SGSN-A and the GGSN (1).

After the location of subscriber "B" is determined, the B party related PDP context is activated (2) in the SGSN-B and the GGSN and PDP PDUs are routed in MO and MT direction. The SGSN-A shall create an S-CDR and the GGSN shall create a G-CDR for subscriber A, the SGSN-B shall create a S-CDR and the GGSN shall create a G-CDR for subscriber "B".

If subscriber "A" and subscriber "B" use the same GGSN, both G-CDRs are produced at that GGSN.

If session leg (2) requires a PDP context activation the respective PDP records will contain a network initiated PDP context activation-flag.

The records generated are subsequently transferred to the CGF (A). The CGF transfers the CDRs to the BS.

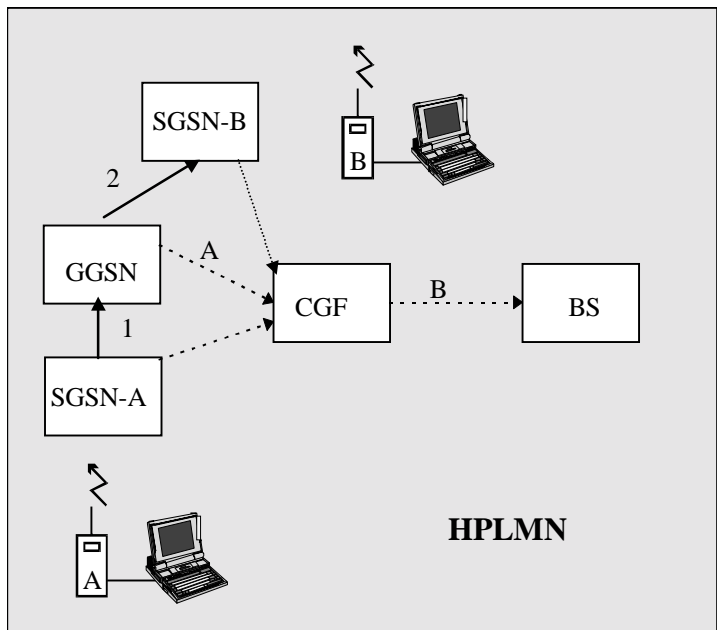

Figure 6: GPRS Mobile to Mobile Context

5.78.3 PDN to GPRS Mobile Context

Figure 7 illustrates a simple incoming GPRS context from a mainframe "A" to GPRS mobile subscriber "B" via a PDN (1). After the location of subscriber "B" is determined, the PDP context is activated (2).

The GGSN receiving the PDUs shall generate a G-CDR whereas the SGSN currently serving subscriber "B" creates an S-CDR. These records contain a flag that the PDP context is activated due to network request.

The records generated are subsequently transferred to the CGF (A). The CGF transfers the CDRs to the BS.

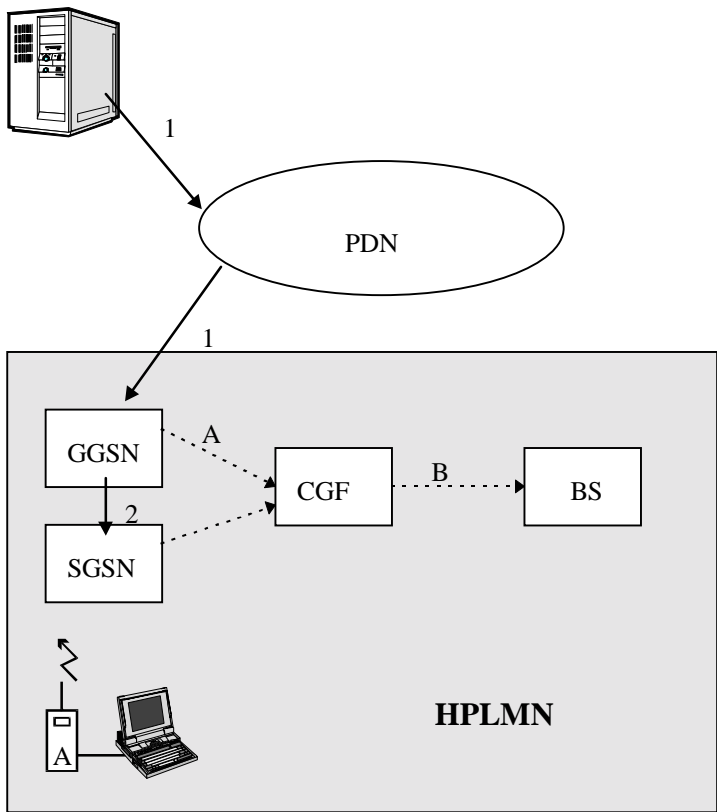

Figure 7: PDN to GPRS Mobile Context

5.7.8.4 GPRS Mobile to PDN Context while roaming, GGSN in HPLMN

Figure 8 illustrates an outgoing GPRS context from a roaming GPRS mobile subscriber "A" to mainframe "B" via Border Gateway, inter PLMN backbone and GGSN of the HPLMN (1).

The respective a-party related PDP context is activated in the SGSN and GGSN and PDUs are routed in MO and MT direction. The SGSN shall create an S-CDR (VPLMN) and a G-CDR is generated at the used GGSN (HPLMN) for subscriber "A". From the GGSN the packets are sent via the PDN to the mainframe "B".

The records generated in the HPLMN and the VPLMN are subsequently transferred to the CGFs (A). The CGFs transfer the CDRs to the BS. (B)

Later on the records created in the VPLMN are transferred from the BS to the BS of the HPLMN via TAP procedure (C).

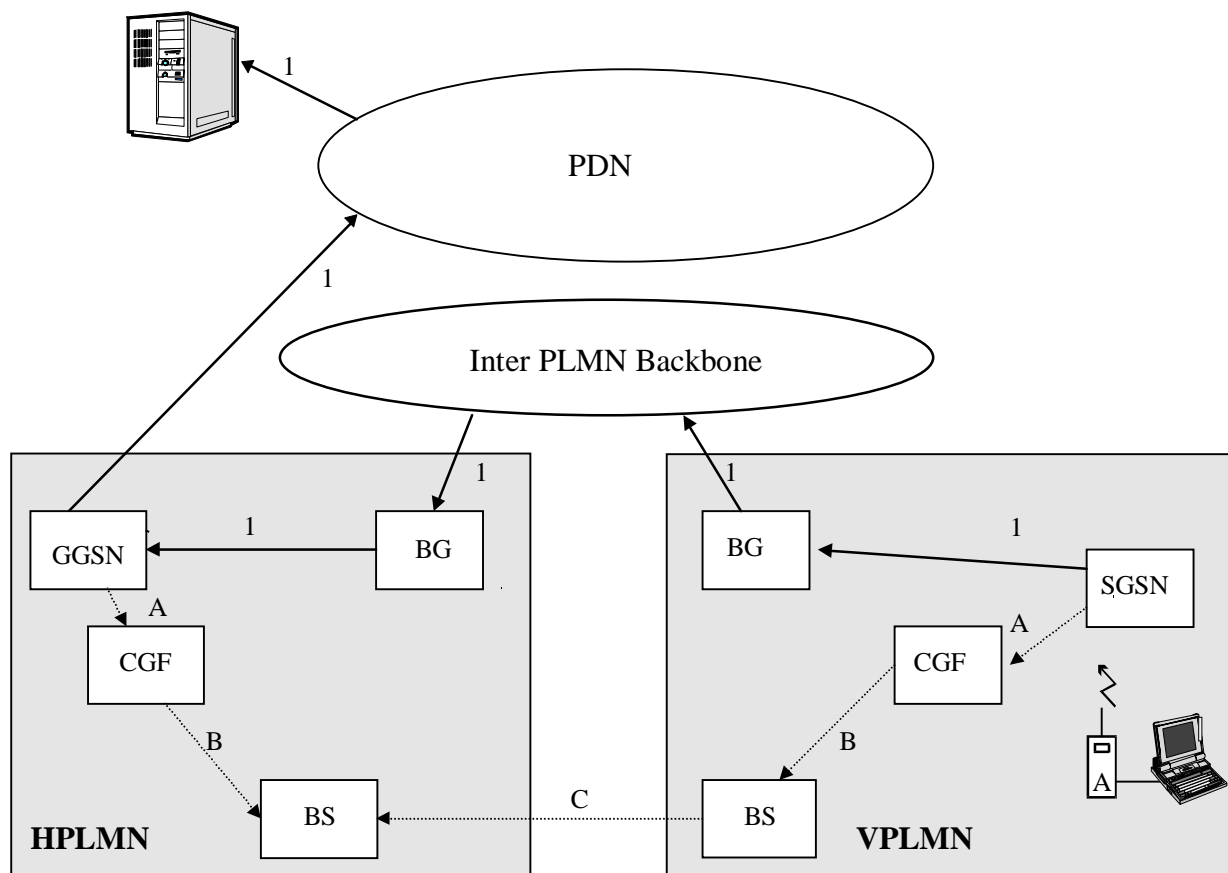

Figure 8: GPRS Mobile to PDN Context whilst roaming via BG

6 Charging Data Collection

6.1 Record contents

The following tables describe the contents of each of the call and event records generated by the GSNs. Each table contains the name of the field, a key indicating whether or not the field is mandatory, and a description of the contents.

The key field has the following meaning:

M This field is mandatory and always present. Any exceptions to this rule are explicitly described.

C This field is only available under certain conditions. If available the field is present.

The conditions under which the field is available are individually described.

O This field is optional and configurable either via additional TMN management functions or manufacturer specific means. For the avoidance of doubt, optional does not mean that the parameter is not supported by the network element. Equipment manufacturers shall be capable of providing all of these fields in order to claim conformance with this document.

The mandatory, conditional, and optional designations are described at the GSN / CGF interface (see exceptions below) and may be available at the CGF / BS interface to meet the Billing System requirement.

All the mandatory or conditional fields are not required in all CDRs at the GSN / CGF interface in the following cases:

- Each information element is included at least in one record. This applies for situations where partial records are produced between the GSN and CGF, and the information has not changed, e.g. "Network Initiated PDP Context". The following primary identifier fields are however needed in all records: Record Type, Served IMSI, and if the CDR is related to a PDP context (G-CDR and S-CDR), GGSN Address, then also the Charging ID.
- GSNs are configured to produce only part of the described information. This applies for situations where record types are not produced or some functional component is excluded from the records such as whole M-CDR or time based charging in G-CDR.

In the case of a distributed CGF the following charging data records are not applicable at the GSN / CGF interface and proprietary solutions or variations to this standard are allowed. However, the described information content needs to be supported to be able to conform to the requirements towards the BS.

6.1.1 GPRS charging data in SGSN (S-CDR)

If the collection of SGSN-CDR data is enabled then the following GPRS-GSM or 3G SGSN data shall be available for each PDP context.

Table 5: GPRS SGSN PDP context data

Field		Description
Record Type	M	GPRS SGSN PDP context record.
Network Initiated PDP Context	C	Present if this is a network initiated PDP context.
Anonymous Access Indicator	C	Set to true to indicate anonymous access (and that the Served IMSI is not supplied)
Sub-System Type	C	Indicates 3G-UMTS Sub-System Support. Not present for GSM GPRS.
Served IMSI	M	IMSI of the served party (if Anonymous Access Indicator is FALSE or not supplied).
Served IMEI	C	The IMEI of the ME, if available.
Served MSISDN	O	The primary MSISDN of the subscriber.
SGSN Address	M	The IP address of the current SGSN.
MS Network Capability	O	The mobile station Network Capability.
Routing Area	O	Routing Area at the time of the record creation.
Local Area Code	O	Location area code at the time of the record creation.
Cell Identity	O	Cell id at the time of the record creation.
Charging ID	M	PDP context identifier used to identify this PDP context in different records created by GSNs
GGSN Address Used	M	The IP address of the GGSN currently used. The GGSN address is always the same for an activated PDP.
Access Point Name Network Identifier	M	The logical name of the connected access point to the external packet data network (network identifier part of APN).
APN Selection Mode	O	An index indicating how the APN was selected.
PDP Type	M	PDP type, e.g. X-25 , IP, PPP, IHQSS:OSP
Served PDP Address	M	PDP address of the served IMSI, e.g. an <u>IP</u> IPv4 or IPv6 or X-121 .
List of Traffic Data Volumes	M	A list of changes in charging conditions for this PDP context, each time stamped. Charging conditions are used to categorise traffic volumes, such as per QoS/tariff period. Initial and subsequently changed QoS and corresponding data values are listed. For <u>In</u> GSM, d <u>D</u> ata volumes are in Octets above the SNDCP layer and are separated for uplink and downlink traffic. For <u>In</u> UMTS3G, d <u>D</u> ata volumes are in octets above the GTP-U layer and are separated for uplink and downlink traffic.
Record Opening Time	M	Time stamp when PDP context activation is created in this SGSN or record opening time on following partial records
Duration	M	Duration of this record in the SGSN.
SGSN Change	C	Present if this is first record after SGSN change.
Cause for Record Closing	M	The reason for the release of record from this SGSN.
Diagnostics	O	A more detailed reason for the release of the connection.
Record Sequence Number	C	Partial record sequence number in this SGSN. Only present in case of partial records.
Node ID	O	Name of the recording entity
Record Extensions	O	A set of network/ manufacturer specific extensions to the record.
Local Record Sequence Number	O	Consecutive record number created by this node. The number is allocated sequentially including all CDR types.
Access Point Name Operator Identifier	M	The Operator Identifier part of the APN.
Charging Characteristics	C	The Charging Characteristics flag set retrieved from the HLR used by the SGSN.

6.1.2 GPRS charging data in GGSN (G-CDR)

If the collection of ~~GGSN-CDR~~ data is enabled then the following ~~GPRS-GSM~~ or ~~3G~~ GGSN data shall be available for each PDP context.

Table 6: GPRS GGSN PDP context data

Field		Description
Record Type	M	GPRS GGSN PDP context record.
Network initiated PDP context	C	Present if this is a network initiated PDP context.
Anonymous Access Indicator	C	Set to true to indicate anonymous access (and that the Served IMSI is not supplied).
System Type Sub-System Type	CC	Indicates 3G-UMTS System ; Not present for GSM GPRS. Indicates 3G-UMTS Sub-System Support
Served IMSI	M	IMSI of the served party (if Anonymous Access Indicator is FALSE or not supplied).
Served MSISDN	O	The primary MSISDN of the subscriber.
GGSN Address	M	The IP address of the GGSN used.
Charging ID	M	PDP context identifier used to identify this PDP context in different records created by GSNs
SGSN Address	M	List of SGSN addresses used during this record.
Access Point Name Network Identifier	M	The logical name of the connected access point to the external packet data network (network identifier part of APN).
APN Selection Mode	O	An index indicating how the APN was selected.
PDP Type	M	PDP type, e.g. X.25 , IP, PPP, or IHOSS:OSP
Served PDP Address	M	PDP address, e.g. an IP IPv4 or IPv6 or X.121 .
Remote PDP Address	O	List of PDP addresses of the remote host or DTE e.g. an IPv4, IPv6, or X.121 (Included if the PDP type is X.25)
Dynamic Address Flag	C	Indicates whether served PDP address is dynamic, that is allocated during PDP context activation.
List of Traffic Data Volumes	M	A list of changes in charging conditions for this PDP context, each time stamped. Charging conditions are used to categorise traffic volumes, such as per tariff period. Initial and subsequently changed QoS and corresponding data values are listed. For In GSM, Data volumes are in octets above the GTP layer and are separated for uplink and downlink traffic. For In UMTS3G, Data volumes are in octets above the GTP-U layer and are separated for uplink and downlink traffic.
Record Opening Time	M	Time stamp when this record was opened.
Duration	M	Duration of this record in the GGSN.
Cause for Record Closing	M	The reason for the release of record from this GGSN.
Diagnostics	O	A more detailed reason for the release of the connection.
Record Sequence Number	C	Partial record sequence number, only present in case of partial records.
Node ID	O	Name of the recording entity.
Record Extensions	O	A set of network/ manufacturer specific extensions to the record.
Local Record Sequence Number	O	Consecutive record number created by this node. The number is allocated sequentially including all CDR types.
Charging Characteristics	C	The Charging Characteristics flag set retrieved from the HLR used by the GGSN.

6.1.3 GPRS mobile station mobility management data in SGSN (M-CDR)

If the collection of MS mobility management data is enabled then ~~GSM GPRS~~ or 3G SGSN shall start collecting information each time the mobile is attached to the SGSN.

Table 7: GPRS SGSN mobile station mobility management data

Field		Description
Record Type	M	GPRS SGSN mobility management record.
Served IMSI	M	IMSI of the MS.
Served IMEI	C	The IMEI of the ME, if available.
Served MSISDN	O	The primary MSISDN of the subscriber.
SGSN Address	M	The IP address of the current SGSN.
MS Network Capability	O	The mobile station network capability.
Routing Area	O	Routing Area at the time of the record creation..
Local Area Code	O	Location Area Code at the time of record creation.
Cell Identity	O	Cell id at the time of the record creation.
Change of Location	O	A list of changes in Routing Area Identity, each time stamped.
Record Opening Time	M	Timestamp when this record was opened.
Duration	O	Duration of this record.
SGSN Change	C	Present if this is first record after SGSN change.
Cause for Record Closing	M	The reason for the release of the record in this SGSN.
Diagnostics	O	A more detailed reason for the release of the connection.
Record Sequence Number	C	Partial record sequence number in this SGSN, only present in case of partial records.
Node ID	O	Name of the recording entity.
Record Extensions	O	A set of network/ manufacturer specific extensions to the record.
Local Record Sequence Number	O	Consecutive record number created by this node. The number is allocated sequentially including all CDR types.
Charging Characteristics	C	The Charging Characteristics flag set retrieved from the HLR-used by the SGSN.
Sub-System Type	C	Indicates 3G-UMTS Sub-System Support. Not present for GSM GPRS.

6.1.4 GPRS MO SMS data in SGSN (S-SMO-CDR)

If enabled, an S-SMO-CDR SGSN Mobile originated SMS record shall be produced for each short message sent by a mobile subscriber via the SGSN.

Table 8: SGSN Mobile originated SMS record

Field		Description
Record Type	M	SGSN Mobile Originated SMS.
Served IMSI	M	The IMSI of the subscriber.
Served IMEI	O	The IMEI of the ME, if available.
Served MSISDN	O	The primary MSISDN of the subscriber.
MS Network Capability	M	The mobile station network capability.
Service Centre	M	The address (E.164) of the SMS-service centre.
Recording Entity	M	The E.164 number of the SGSN.
Location Area Code	O	The Location Area Code from which the message originated.
Routing Area Code	O	The Routing Area Code from which the message originated.
Cell Identity	O	The Cell Identity from which the message originated.
Event Time Stamp	M	The time at which the message was received by the SGSN from the subscriber.
Message Reference	M	A reference, provided by the MS uniquely identifying this message.
SMS Result	C	The result of the attempted delivery if unsuccessful.
Record Extensions	O	A set of network/ manufacturer specific extensions to the record.
Node ID	O	Name of the recording entity.
Local Record Sequence Number	O	Consecutive record number created by this node. The number is allocated sequentially including all CDR types.
Charging Characteristics	C	The Charging Characteristics flag set retrieved from the HLR <u>used by the SGSN</u> .
Sub-System Type	C	Indicates 3G-UMTS Sub-System Support. Not present for GSM GPRS.

6.1.5 GPRS MT SMS data in SGSN (S-SMT-CDR)

If enabled, an SGSN Mobile terminated SMS record shall be produced for each short message received by a mobile subscriber via the SGSN.

Table 9: SGSN Mobile terminated SMS record

Field		Description
Record Type	M	SGSN Mobile terminated SMS.
Served IMSI	M	The IMSI of the subscriber.
Served IMEI	O	The IMEI of the ME, if available.
Served MSISDN	O	The primary MSISDN of the subscriber.
MS Network Capability	M	The mobile station network capability
Service Centre	M	The address (E.164) of the SMS-service centre.
Recording Entity	M	The E.164 number of the SGSN.
Location Area Code	O	The Location Area Code to which the message was delivered.
Routing Area Code	O	The Routing Area Code to which the message was delivered.
Cell Identity	O	The Cell Identity to which the message was delivered.
Event Time Stamp	M	Delivery time stamp, time at which message was sent to the MS by the SGSN.
SMS Result	C	The result of the attempted delivery if unsuccessful.
Record Extensions	O	A set of network/ manufacturer specific extensions to the record.
Node ID	O	Name of the recording entity.
Local Record Sequence Number	O	Consecutive record number created by this node. The number is allocated sequentially including all CDR types.
Charging Characteristics	C	The Charging Characteristics flag set retrieved from the HLR, used by the SGSN.
Sub-System Type	C	Indicates 3G-UMTS Sub-System Support Not present for GSM GPRS.

6.1.6 Description of Record Fields

This subclause contains a brief description of each field of the CDRs described in the previous subclause.

6.1.6.1 Access Point Name

This field contains the logical Access Point Name used to determine the actual connected access point. APN comprises of network identifier and operator identifier. APN can also be a wildcard, in which case SGSN selects the access point address. See TS 23.003 [4] and TS 23.060 [8] for more information about APN format and access point decision rules.

6.1.6.x APN Selection Mode

This field indicates how the SGSN selected the APN to be used. The values and their meaning are as specified in TS 29.060 [22] subclause 7.9 'Information elements'.

6.1.6.2 Cause for Record Closing

This field contains a reason for the release of the CDR including the following:

- normal release: PDP context release or GPRS detach;
- partial record generation: data volume limit, time (duration) limit, SGSN change or maximum number of changes in charging conditions;
- abnormal termination (PDP or MM context);
management intervention (request due to O&M reasons).

A more detailed reason may be found in the diagnostics field.

6.1.6.x Charging Characteristics

The Charging Characteristics field allows the operator to apply different kind of charging methods for the CDRs. The N flag in the Charging Characteristics indicates normal charging, the P flag indicates prepaid charging, the F flag indicates flat rate charging and the H flag indicates charging by hot billing. One or more of the flags shall be set according to the charging characteristics received from the HLR and transmitted by the CDR generating node over the Ga interface.

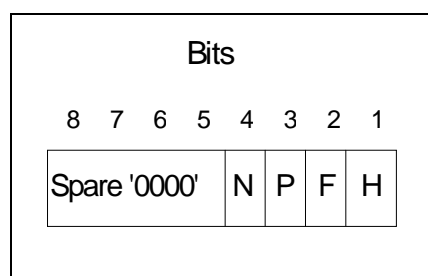

Figure 8a: Charging Characteristics flags

6.1.6.3 Charging ID

This field is a charging identifier, which can be used together with GGSN address to identify all records produced in SGSN(s) and GGSN involved in a single PDP context. Charging ID is generated by GGSN at PDP context activation and transferred to context requesting SGSN. At inter-SGSN routing area update charging ID is transferred to the new SGSN as part of each active PDP context.

Different GGSNs allocate the charging ID independently of each other and may allocate the same numbers. The CGF and/or BS may check the uniqueness of each charging ID together with the GGSN address and optionally (if still unambiguous) with the record opening time stamp.

6.1.6.4 Diagnostics

This field includes a more detailed technical reason for the release of the connection and may contain one of the following:

- a MAP error from TS 29.002 [21];
- a Cause from TS 24.008 [13].

The diagnostics may also be extended to include manufacturer and network specific information.

6.1.6.5 Duration

This field contains the relevant duration in seconds for PDP contexts (S-CDR, G-CDR, and attachment (M-CDR)). For partial records this is the duration of the individual partial record and not the cumulative duration.

It should be noted that the internal time measurements may be expressed in terms of tenths of seconds or even milliseconds and, as a result, the calculation of the duration may result in the rounding or truncation of the measured duration to a whole number of seconds.

Whether or not rounding or truncation is to be used is considered to be outside the scope of this Specification subject to the following restrictions:

- 1) A duration of zero seconds shall be accepted providing that the transferred data volume is greater than zero.
- 2) The same method of truncation/rounding shall be applied to both single and partial records.

6.1.6.6 Dynamic Address Flag

This field indicates that PDP address has been dynamically allocated for that particular PDP context. Field is missing if address is static i.e. part of PDP context subscription. Dynamic address allocation might be relevant for charging e.g. the duration of PDP context as one resource offered and possible owned by network operator.

6.1.6.7 Event Time Stamps

These fields contain the event time stamps relevant for each of the individual record types.

All time-stamps include a minimum of date, hour, minute, and second.

6.1.6.8 GGSN Address/GGSN Address Used

These fields contain one IP address of GGSN.

The S-CDR fields contain a single address of current GGSN used.

The G-CDR fields contain an address of current GGSN.

6.1.6.9 List of Traffic Data Volumes

This list includes one or more containers, which each include the following fields:

Data Volume Uplink, Data Volume Downlink, Change Condition and Time Stamp.

Data Volume includes the number of octets transmitted during the use of packet data services.

Change condition defines the reason for closing the container (see 5.7.1 and 5.7.3), such as tariff time change, QoS change or closing the CDR. Change time is a time stamp which defines the moment when the new volume counts are started or CDR is closed. All the active PDP contexts do not need to have exactly the same time stamp e.g. due to same tariff time change (variance of the time stamps is implementation and traffic load dependent and is out of the scope of standardisation).

First container includes following optional fields: QoS Requested (not in G-CDR) and QoS Negotiated. In following containers QoS Negotiated is present if previous change condition is QoS change.

Following is an example of a list, which has three containers (sets of volume counts) caused by one QoS change and one tariff time change.

Table 10: Example list of traffic data volumes

QoS Requested = QoS1 QoS Negotiated = QoS1	QoS Negotiated = QoS2	
Data Volume Uplink = 1 Data Volume Downlink = 2	Data Volume Uplink = 5 Data Volume Downlink = 6	Data Volume Uplink = 3 Data Volume Downlink = 4
Change Condition = QoS change Time Stamp = TIME1	Change Condition = Tariff change Time Stamp = TIME2	Change Condition = Record closed Time Stamp = TIME3

First container includes initial QoS values and corresponding volume counts. Second container includes new QoS values and corresponding volume counts before tariff time change. Last container includes volume counts after the tariff time change. Following total volume counts can be itemised (tariff1 is used before and tariff2 after the tariff time change):

		Container
QoS1+Tariff1	uplink = 1, downlink = 2	1
QoS2+Tariff1	uplink = 5, downlink = 6	2
QoS2+Tariff2	uplink = 3, downlink = 4	3
QoS1	uplink = 1, downlink = 2	1
QoS2	uplink = 8, downlink = 10	2+3
Tariff1	uplink = 6, downlink = 8	1+2
Tariff2	uplink = 3, downlink = 4	1

The amount of data counted in the GGSN shall be the data volume sent over the GTP layer. Therefore the data counted already includes the IP/X.25-PDP bearer protocols. I.e. IP, TCP or UDP Headers.

The data volume counted in the SGSN covers the amount of data transferred in the SNDCP PDUs. Therefore the data counted already includes the overheads of any IP/X.25-PDP bearer protocols.

The amount of data counted in the 3G-GGSN shall be the data volume sent over the GTP-U layer. Therefore the data counted already includes the overheads of any PDP bearer protocols.

The data volume counted in the 3G-SGSN covers the amount of data transferred in the GTP-U PDUs. Therefore the data counted already includes the overheads of any PDP bearer protocols.

In GSM, In order to avoid that downstream packets transmitted from the old SGSN to the new SGSN at inter SGSN RA update induce the increase of the PDP CDR downstream volume counters in both SGSN the following rule is followed:

- for PDP contexts using LLC in unacknowledged mode: an SGSN shall update the PDP CDR when the packet has been sent by the SGSN towards the MS;
- —for PDP contexts using LLC in acknowledged mode: an SGSN shall only update the PDP CDR at the reception of the acknowledgement of the correct reception of a downstream packet by the MS. This implies that for downstream packets under transmission at inter SGSN RA update a packet sent by the old SGSN actually received by the MS and acknowledged by the MS towards the new SGSN through the RA update complete message induces the update of the PDP CDR record by the new SGSN.

In 3G UMTS, ???

Data volumes retransmitted (by RLC or LLC) due to poor radio link conditions shall not be counted.

In 3G, ???

6.1.6.10 Local Record Sequence Number

This field includes a unique record number created by this node. The number is allocated sequentially including all CDR types. The number is unique within one node, which is identified either by field Node ID or by record dependent node address (SGSN address, GGSN address, Recording Entity).

The field can be used e.g. to identify missing records in post processing system.

6.1.6.11 Message reference

This field contains a unique message reference number allocated by the mobile station when transmitting a short message to the service centre. This field corresponds to the TP-Message-Reference element of the SMS_SUBMIT PDU defined in TS 23.040.

6.1.6.12 MS Network Capability

This MS Network Capability field contains the MS network capability value of the MS network capability information element of the served MS on PDP context activation or on GPRS attachment as defined in TS 24.008 [13].

6.1.6.13 Network Initiated PDP Context

This field indicates that PDP context is network initiated. The field is missing in case of mobile activated PDP context.

6.1.6.14 Node ID

This field contains an optional operator configurable identifier string for the node which generated the CDR.

6.1.6.15 PDP Type

This field defines the PDP type, e.g. ~~X.25~~-IP, PPP, or IHQSS:OSP (see TS 29.060 for exact format).

6.1.6.16 QoS Requested/QoS Negotiated

Quality of Service Requested contains the QoS wanted by MS at PDP context activation. QoS Negotiated indicates the applied QoS accepted by the network.

~~The In GSM, the QoS profile consists of 5 attributes: reliability, delay, precedence, peak throughput and mean throughput. See TS 23.060 TS 24.008-[138] for more details.~~

In 3G, the QoS profile consists of the following attributes: Traffic class ('conversational', 'streaming', 'interactive', 'background'), Maximum bitrate (kbps), Delivery order (y/n), Maximum SDU size (octets), SDU error ratio, Residual bit error ratio, Delivery of erroneous SDUs (y/n/-), Transfer delay (ms), Traffic handling priority, Allocation/Retention Priority. See TS 24.008 [13] for more details.

6.1.6.17 Record Extensions

The field enables network operators and/or manufacturers to add their own Recommendation extensions to the standard record definitions. This field contains a set of "management extensions" as defined in CCITT X.721 [5].

6.1.6.18 Record Opening Time

This field contains the time stamp when the record is opened (see ~~TS 32.005 [23]~~TS 32.005 [23]~~GSM 12.05~~ for exact format).

Record opening reason does not have a separate field. For G-CDR and M-CDR it can be derived from the field "Sequence number" i.e. missing field or value one means activation of PDP context and GPRS attachment. For S-CDR also field "SGSN change" need to be taken into account.

6.1.6.19 Record Sequence Number

This field contains a running sequence number employed to link the partial records generated in the SGSN/GGSN for a particular PDP context (characterised with same the Charging ID and GGSN address pair). In the S-CDR the sequence number is always started from one after inter-SGSN routing area update, see field "SGSN change". The Record Sequence Number is missing if the record is the only one produced in the SGSN/GGSN for the PDP context (e.g. inter-SGSN routing area update can result to two S-CDRs without sequence number and field "SGSN update" present in the second record).

6.1.6.20 Record Type

The field identifies the type of the record e.g. S-CDR, G-CDR, M-CDR, S-SMO-CDR and S-SMT-CDR.

6.1.6.21 Recording Entity Number

This field contains the ITU-T E.164 number assigned to the entity that produced the record. For further details see TS 23.003 [4].

6.1.6.22 ~~Remote PDP Address~~ 'Void'

~~Remote PDP address may be used if PDP type is X.25. This parameter is not used if the PDP type is IP, PPP, or IHQSS:OSP. Itemised volume billing is available per Access Point Name. This field contains a list of connected remote PDP addresses.~~

6.1.6.23 Routing Area Code/Cell Identity/Change of location

The location information contains a combination of the Routing Area Code (RAC) and optionally Cell Identity (CI) of the routing area and cell in which the served party is currently located. Any change of location (i.e. Routing Area change) may be recorded in the change of location field including the time at which the change took place.

The change of location field is optional and not required if partial records are generated when the location changes.

The RAC and (optionally) CI are coded according to TS 24.008 [13].

6.1.6.24 Served IMEI

This field contains the international mobile equipment identity (IMEI) of the equipment served. The term "served" equipment is used to describe the ME involved in the transaction recorded e.g. the called ME in the case of a network initiated PDP context.

The structure of the IMEI is defined in TS 23.003 [4].

6.1.6.25 Served IMSI

This field contains the international mobile subscriber identity (IMSI) of the served party. The term "served" party is used to describe the mobile subscriber involved in the transaction recorded e.g. the calling subscriber in case of a mobile initiated PDP context.

The structure of the IMSI is defined in TS 23.003 [4].

6.1.6.26 Served MSISDN

This field contains the mobile station ISDN number (MSISDN) of the served party. The term "served" party is used to describe the mobile subscriber involved in the transaction recorded e.g. the called subscriber in case of an MTC record. In case of multi-numbering the MSISDN stored in a MOC record will be the primary MSISDN of the calling party.

The structure of the MSISDN is defined in TS 23.003 [4].

6.1.6.27 Served PDP Address

This field contains the PDP address of the served IMSI. This is a network layer address ~~e.g.~~ i.e. of type IP version 4, IP version 6 or X.121. The address for each PDP type is allocated either temporarily or permanently, see field "Dynamic Address Flag".

6.1.6.28 Service Centre Address

This field contains a CCITT E.164 number identifying a particular service centre e.g. short message service centre (see TS 23.040).

6.1.6.29 SGSN Address

These fields contain one or several IP addresses of SGSN.

The S-CDR fields contain single address of current SGSN and GGSN used.

The G-CDR fields contain the address of the current GGSN and a list of SGSNs, which have been connected during the record (SGSN change due to inter SGSN Routing Area update).

The M-CDR only contains the address of the current SGSN. The M-CDR does not identify any information related to active PDP context(s) and thus does not know connected (used) GGSN(s).

6.1.6.30 SGSN Change

This field is present only in the S-CDR to indicate that this is the first record after an inter-SGSN routing area update.

6.1.6.31 Short Message Service Result

This field contains the result of an attempt to deliver a short message either to a service centre or to a mobile subscriber (see TS 29.002). Note that this field is only provided if the attempted delivery was unsuccessful.

6.1.6.32 ~~6.1.6.32~~ System Type

This field is present conditionally, indicating the use of a 3G air interface for the provision of service recorded by this CDR.

In the case of service provided by a GSM air interface, the field is not present.

APN Selection Mode

This field indicates how the SGSN selected the APN to be used. The values and their meaning are as specified in TS 29.060 [22] subclause 7.9 'Information elements'.

6.1.6.33 Charging Characteristics

~~The Charging Characteristics field allows the operator to apply different kind of charging methods for the CDRs. The N flag in the Charging Characteristics indicates normal charging, the P flag indicates prepaid charging, the F flag indicates flat rate charging and the H flag indicates charging by hot billing. One or more of the flags shall be set according to the charging characteristics received from the HLR and transmitted by the CDR generating node over the Ga interface.~~

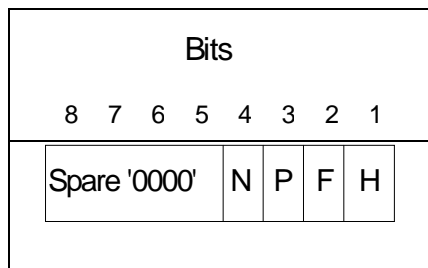

Figure 8a: Charging Characteristics flags

7 Charging Protocols

The GTP' charging protocol is optional. GPRS nodes generate CDRs. These CDRs are to be collected by the CGF. The protocol GTP' has been designed to provide this CDR collection.

The CGF-BS interface is also described in this subclause.

7.1 GPRS CDR Collection by GTP' Protocol

The GTP' protocol has been designed to deliver GPRS CDR's to the CGF(s) from those network elements or functional entities generating charging records. The GTP' protocol is required when the CGF resides in alternate nodes to those CDR generating nodes (e.g the SGSN and GGSN). The GTP' protocol designed for GPRS charging data collection has been derived from the GTP protocol (defined in TS 29.060) which is used for packet data tunnelling in the GPRS backbone network.

GTP' is based on GTP with enhancements and additional message types. GTP' operates on the Ga interface. GTP' however does not imply the use of the GPRS backbone network, and may be implemented on alternate bearers.

The GTP' contains the following functions:

- CDR transfer mechanism between GPRS nodes generating CDRs and the Charging Gateway Functionality.
- Redirection of CDR transfer to another CGF.
- Ability to detect communication failures between the CDR handling GPRS network elements by echo messaging.
- Ability of a CDR handling node to advertise the peer CDR handling GPRS network elements about its CDR transfer capability (e.g. after a period of service downtime).
- Ability to prevent duplicate CDRs that might arise during redundancy operations. If so configured, the CDR duplication prevention function may also be carried out by marking potentially duplicated CDR packets and delegating the final duplicate deletion task to CGF or Billing System (instead of handling the possible duplicates solely by GTP' messaging).
- The aim of the duplication prevention support of GTP' is to reduce the number of duplicated CDRs sent towards the BS and to support the BS in keeping the efforts for duplicate CDR checking as small as possible.

7.1.1 SGSN - CGF communication

SGSN - CGF: GTP' over UDP/TCP and IP

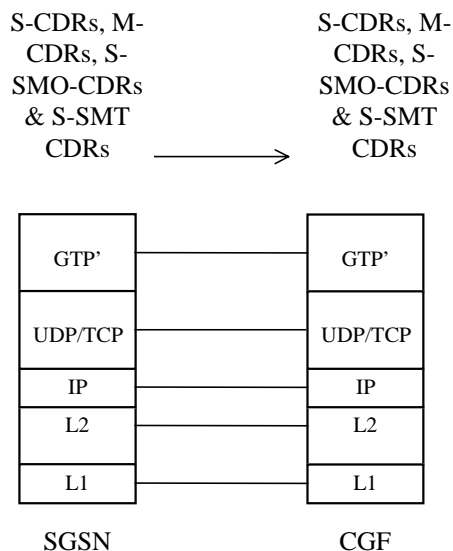

Figure 9: Protocol layers between the SGSN and the CGF

7.1.2 GGSN - CGF communication

GGSN - CGF: GTP' over UDP/TCP and IP:

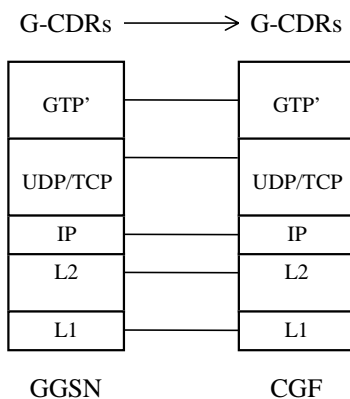

Figure 10: Protocol layers between the GGSN and the CGF

7.1.3 CGF - CGF communication

CGF - CGF: GTP' over UDP/TCP and IP:

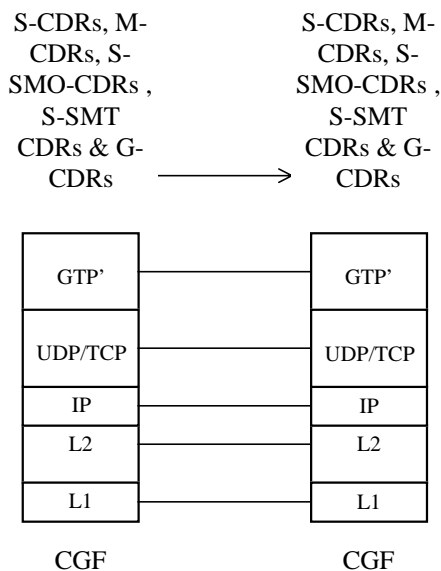

Figure 11: Protocol layers between CGFs

7.1.4 Port usage

GPRS charging may be facilitated by sending the CDRs from the GSNs to the CGF over the Ga interface. The Path Protocol may be UDP [compliant with STD0006] or TCP [compliant with STD 0007].

7.1.4.1 UDP as the Path Protocol

Ports for signalling the request messages:

- The UDP Destination Port may be the server port number 3386 which has been reserved for GTP. Alternatively another port can be used which has been configured by O&M.
- The UDP Source Port is a locally allocated port number at the sending GSN.

Ports for signalling the response messages:

- The UDP Destination Port value shall be the value of the Source Port of the corresponding request message.
- The UDP Source Port shall be the value from the Destination Port of the corresponding request message.

7.1.4.2 TCP as Path Protocol

The TCP Destination Port may be the server port number 3386 which has been reserved for G-PDUs. Alternatively another port may be used as configured by O&M. Extra implementation specific destination ports are possible but all CGFs shall support the server port number.

The TCP Source Port is a random port, locally assigned at the sending GSN.

7.1.4.3 Network layer and lower layers

Beneath the Path Protocol there is the network IP layer which shall be the Internet Protocol (IP) compliant with STD 0005. Beneath the network IP layer are the L2 and L1 layers, which are not specified in this document.

7.1.5 Charging related requirements for GPRS nodes

Each GPRS node (SGSN, GGSN, CGF, and in future the PTM-SC) supporting GTP' shall be capable of handling or responding with a "Service/Version not supported" message if that node is configured to be addressed by another GPRS node.

When a new PDP context is activated or after an inter SGSN handover the GGSN will inform the related SGSN which CGF it should send its CDRs to. All other non PDP context related CDRs are sent to the current default CGF for that CDR generating node. Each CDR generating node will have an O&M configurable CGF address list to which it can send its CDRs. The list will be organized in CGF address priority order. If the Primary CGF is e.g. out of service, then the CDR generating node shall send the CDRs to the Secondary CGF and so on.

Each GPRS CDR generating node will only send the records to the CGF(s) of the same GPRS PLMN, not to CGF(s) located in other PLMNs.

Each CGF in the GPRS PLMN shall know of all other CGFs network addresses. This is achieved by O&M configuration facilities that will enable each CGF to have a configurable list of peer CGF addresses.

7.2 The GTP' charging protocol

This subclause describes the necessary enhancements and additional message types to the basic GTP protocol, described in TS 29.060, for GPRS charging data collection.

7.2.1 Usage of GTP Header in charging

The start of the GTP header defined in TS 29.060 is reused. In GPRS charging, only the signalling plane of GTP is partly reused.

Bit 5 of octet 1 of the GTP header is the Protocol Type flag and is '0' if the message is GTP'.

The Version bits indicate the GTP' protocol version when the Protocol Type flag is '0'.

Bit 1 of octet 1 is not used in GTP' (except in v0), and it is '0' in the GTP' header.

The Length indicates the length of payload (number of octets after the GTP' header).

The Sequence Number of the packet is part of the GTP' header.

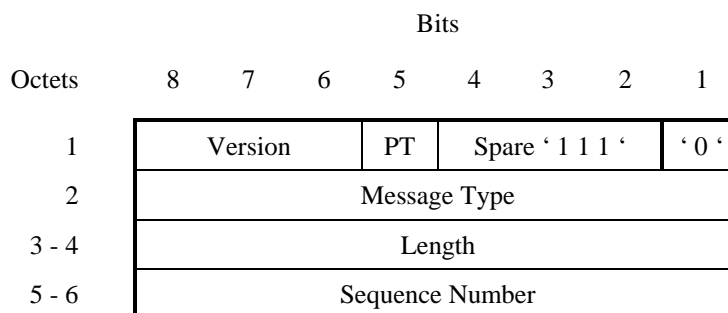

Figure 12: GTP' header

7.2.2 Information elements

Signalling messages may contain several information elements. The TLV (Type, Length, Value) or TV (Type, Value) encoding formats shall be used for the GTP' information elements. The signalling messages for GTP' shall have the information elements sorted with the Type fields in ascending order. The Length field shall contain the information element length excluding the Type and Length fields.

Within the Type field the most significant bit will be set to 0 when the TV format is used and set to 1 when the TLV format is used.

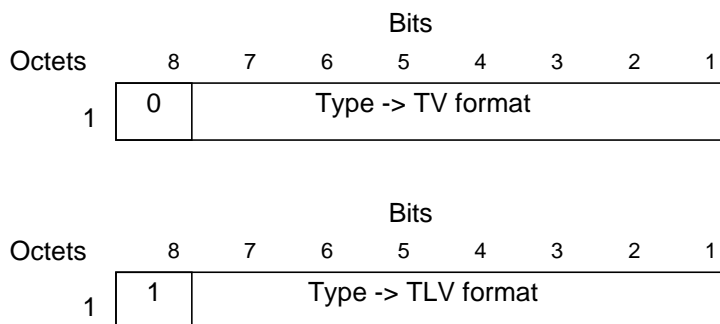

Figure 12a: Type field for TV and TLV format

7.3 GTP' Message Types

7.3.1 List of all GTP' message types

GTP defines a set of signalling messages between two associated GSN nodes. The signalling messages defined are shown in table 11. The enhancements introduced by GTP' are printed in this table in **boldface**. The messages modified due to the GPRS charging requirements are printed in *italics*.

Of the new signalling message types, Node Alive Request, Node Alive Response, Redirection Request and Redirection Response belong to the Path Management messages. The Data Record Transfer Request and Data Record Transfer Response form a new GTP signalling message type group: Record Transmission messages.

The reserved fields in the signalling messages shall be filled with ones, and are intended for future use.

GTP' shall reuse the GTP Cause values. The GTP' message type numbers needed for charging have been derived from the unallocated message type number space specified in TS 29.060.

The number ranges allocated for GTP' are as follows:

For Information Elements: 117-127 (TV type fields) and 239-254 (for TLV type fields).

TLV Information Element types introduced in this specification:

- 254 Address of Recommended Node
- 253 Requests Responded
- 252 Data Record Packet
- 251 Charging Gateway Address (this IE is also used in TS 29.060)
- 250 Sequence Numbers of Cancelled Packets
- 249 Sequence Numbers of Released Packets

TV Information Element types introduced in this specification:

- 127 Charging ID
- 126 Packet Transfer Command

For Cause Codes: Cause values used in requests: 49 to 63, Cause values used in responses indicating acceptance: 177 to 191, Cause values used in responses indicating rejection: 241 to 255.

Charging related Cause values introduced for this specification:

In requests:

- 63 This node is about to go down
- 62 Another node is about to go down
- 61 The receive buffers are becoming full
- 60 The transmit buffers are becoming full
- 59 System failure

In responses indicating acceptance:

-

In responses indicating rejection:

- 255 Request not fulfilled
- 254 Sequence numbers of released/cancelled packets IE incorrect
- 253 Request already fulfilled
- 252 Request related to possibly duplicated packets already fulfilled

The charging related message types are listed in the following signalling message table. If the Signalling Messages table defined in TS 29.060 differs other than the boldfaced message types in table 11, then the defined signalling table in TS 29.060 shall be considered as the latest version of the two tables.

Table 11: Signalling messages

Message Type value (Decimal)	Signalling message
1	Echo Request
2	Echo Response
3	Version Not Supported
4	Node Alive Request
5	Node Alive Response
6	Redirection Request
7	Redirection Response
16	Create PDP Context Request
17	Create PDP Context Response
18	Update PDP Context Request
19	Update PDP Context Response
20	Delete PDP Context Request
21	Delete PDP Context Response
22	Create AA PDP Context Request
23	Create AA PDP Context Response
24	Delete AA PDP Context Request
25	Delete AA PDP Context Response
26	Error Indication
27	PDU Notification Request
28	PDU Notification Response
29	PDU Notification Reject Request
30	PDU Notification Reject Response
32	Send Routing Information for GPRS Request
33	Send Routing Information for GPRS Response
34	Failure Report Request
35	Failure Report Response
36	Note MS GPRS Present Request
37	Note MS GPRS Present Response
48	Identification Request
49	Identification Response
50	SGSN Context Request
51	SGSN Context Response
52	SGSN Context Acknowledge
240	Data Record Transfer Request
241	Data Record Transfer Response
255	T-PDU
others	reserved for future use

7.3.2 Reused GTP message types

The existing **Echo Request** and **Echo Response** messages defined in TS 29.060 are also used in GPRS charging. They may be used by the CDR generating nodes SGSN or GGSN, or by the CGF for checking if another GSN or CGF is alive. If this specification and TS 29.060 differ in their description then the TS 29.060 is to be taken as the latest specification status of the related Information elements. If the path protocol is TCP, Echo Request and Echo Response messages are not required.

The **Version Not Supported** message in the GTP' resembles much the corresponding GTP message. It indicates the latest GTP' version that the GTP' entity can support. If a receiving node receives a GTP' signalling message of an unsupported version, that node shall return a GTP' Version Not Supported message indicating in the Version field of the GTP' header the latest GTP' version that that node supports. The received payload data of the GTP' packet shall then be discarded.

The Version bits in the GTP' header have currently the following possible values:

GTP' version 0 (binary '000') is the GSM 12.15 v7.0.0 (October 1998) level, with the following Message Type values: 3 = Version Not Supported, 4 = Node Alive Request, 5 = Node Alive Response, 6 = Redirection Request, 7 = Redirection Response. In Chapter 7.3.4.6 the Requests Responded information element has Length field in place of the Number of Requests Responded field, to make that TLV IE to be handled like normal TLV IEs. If the GTP' v0 is used in parallel to GTP' v2 or a newer version, then a 6 octet header length (with no trailing dummy octets) is used also with v0 (like in GTP' v2). The mark of the usage of GTP' v0 with 6 octet header (instead of the original 20 octet long header) is then the version bits being 0 and the bit 1 of octet 1 being '1' (instead of '0').

GTP' version 1 (binary '001') is the same as version 0, but with the duplicate CDR prevention mechanism, introduced in this specification version.

GTP' version 2 (binary '010') is the same as version 1, but the header is just 6 octets long (No unused trailing octets).

7.3.3 GTP message type modifications implied by GTP'

The GPRS charging related features in GTP are in the Create PDP Context Response: the Charging ID information element and the Charging Gateway Address IE, in the Update PDP Context Response the Charging Gateway Address IE, in the Create AA PDP Context Response: the Charging ID IE and the Charging Gateway Address IE. Refer to the TS 29.060 for the details.

The general principle is that the CDRs are always sent to a CGF residing in the same network as the CDR generating node. In the case of roaming it is conceivable that some CDRs relating to the same PDP context will be sent to different networks' CGFs. The cost balancing of the roaming traffic is to be agreed between the GPRS Operators.

7.3.4 GTP' message types

7.3.4.1 Node Alive Request

The Node Alive Request message may be used to inform that a node in the network has started its service (e.g. after a service break due to software or hardware maintenance or data service interruption after an error condition). A node may send a different Node Address than its own in the information element, e.g. informing the "next node in the chain" that the "previous node in the chain" (which is located on the other side of the sender of this message) is now ready for service. This message type is optional if the Path Protocol is TCP.

The Node Alive Request message allows a quicker reconnect capability than the Echo Request message based polling can provide, and its usage will have a reduced load effect on the network, particularly when the number of network nodes using GTP' is high. It may also be used to inform when a new network node has become available for service. If the Echo Request message is also used then the usage of the Node Alive Request message allows the interval of Echo Requests to be longer than would be otherwise required, thus reducing network loading with many Echo Requests.

Table 12: Information elements in a Node Alive Request

Information element	Presence requirement
Node Address	Mandatory
Private Extension	Optional

The Node Address format is the same as for the Charging Gateway Address format described earlier in this specification.

The optional Private Extension information element contains vendor or operator specific information.

7.3.4.2 Node Alive Response

The Node Alive Response message shall be sent as a response to a received Node Alive Request.

Table 13: Information elements in a Node Alive Response

Information element	Presence requirement
Private Extension	Optional

The optional Private Extension information element contains vendor or operator specific information.

7.3.4.3 Redirection Request

There are two kinds of usage for the Redirection Request message. One is to advise that received CDR traffic is to be redirected to another CGF due to that CGF node is about to stop service (due to an outage for maintenance or an error condition). The second purpose is to inform a CDR generating node (e.g. SGSN) that is currently sending data to this node (e.g. CGF), that the next node in the chain (e.g. a mediator device or Billing Computer) has lost connection to this node (e.g. CGF).

An Address of Recommended Node may be given if for example a CGF maintenance outage is handled by first introducing another CGF ready to take incoming CDRs. In this way the network performance can be maintained. The Address of Recommended Node shall only describe an intra-PLMN node containing a CGF, and not to a node in any other PLMN.

Table 14: Information elements in a Redirection Request

Information element	Presence requirement
Cause	Mandatory
Address of Recommended Node	Optional
Private Extension	Optional

Possible Cause values are:

- "This node is about to go down"
- "Another node is about to go down"
- "System failure"
- "Receive buffers becoming full"
- "Send buffers becoming full"

The Address of Recommended Node information element defines the IPv4 or IPv6 format address that the node is identified by in the GPRS network.

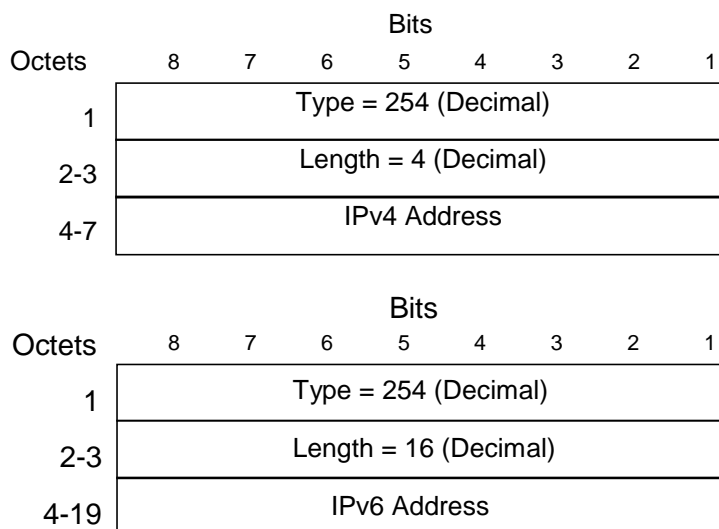

Figure 13: Address of Recommended Node information elements

The optional Private Extension contains vendor or operator specific information.

7.3.4.4 Redirection Response

The message shall be sent as a response of a received Redirection Request.

Table 15: Information elements in a Redirection Response

Information element	Presence requirement
Cause	Mandatory
Private Extension	Optional

Possible Cause values are:

- "Request Accepted"
- "No resources available"
- "Service not supported"
- "System failure"
- "Mandatory IE incorrect"
- "Mandatory IE missing"
- "Optional IE incorrect"
- "Invalid message format"
- "Version not supported"

The optional Private Extension contains vendor or operator specific information.

7.3.4.5 Data Record Transfer Request

This message is used in GPRS charging to transmit the CDR information. The CDR information is placed in the Data Record information element.

7.3.4.5.1 General logic

This subclause is intended to be read together with subclause 7.3.4.7 "Examples of GTP' messaging cases". The normal communication would be GSN sending Data Record Packets to a CGF, which answers with "Request Accepted" responses. Under normal condition the CDR transmission uses a Request-Response messaging sequence in the GSN to CGF GTP' protocol communication.

Sometimes a non-PDP context related CDR (e.g. M-CDRs) is transmitted, and thus the GGSN does not pass the CGF address information to the SGSN. The SGSN will in this case direct the CDRs to the current default CGF for the SGSN. This is the configured Primary CGF address, or if that CGF is out of service, then the secondary CGF address etc.

Summary of the CGF redundancy mechanism that prevents duplicated CDR packets to enter the BS:

The general logic of the duplicate CDR packet prevention in CGF redundancy cases is shown in the following diagram, where the message numbers are numbered in the order of time sequence. Alternative messages are indicated by an index character ('a' or 'b') that follows the arrow sequence number.

The main mechanism of the messaging in CGF redundancy cases (when a GSN-CGF link is down or a CGF is not working) is based on (1) first trying to send a CDR packet to CGF1. Then if no successful response is received (2) because the request does not reach CGF1 even when retried (or the responses from CGF1 to GSN are lost after CGF1 either stored it securely or sent it towards post-processing (2b)), the unacknowledged CDR packets are redirected to CGF2. The GSN may first test the GSN-CGF2 link by a Echo Request message, that the CGF2 would respond by Echo Response. The CDR packets not successfully received by the primary CGF (=CGF1) are sent to another CGF2 (3), marked as potential duplicates, and CGF2 responds the request(s) (4). Those CDRs will wait there for further commands from GSN. When the GSN detects (5) and (6) that CGF1 is again able to communicate with it by receiving Node Alive Request (or getting a Echo Response from CGF2 to a Echo Request sent by the GSN) it answers by Node Alive Respond. Then the GSN tests with an empty packet (7), retrying continuously if no response, using e.g. increasing timeouts (using the old unacknowledged packet's Sequence Number, if the CGF1 would consider the packet to be a new one (8a) or an already received one (8b)). According to the response of the CGF1, the GSN gives the CGF2 a command to either release (9a) or cancel (9b) the corresponding CDR packet from CGF2. CGF2 then confirms the decision (10), and is able to send the CDRs towards the BS (11a).

Error handlings: As a default, retransmissions after configurable timeouts are used. If after CGF1 communication failure the CDR packet sending from GSN to CGF2 does not succeed, the GSN tries to use CGF3 as the intermediate CDR

packet storage entity, etc. If the acknowledgement (10) is not got by the GSN for its message (9a) or (9b), the GSN will retransmit the message (9a) or (9b) continuously and persistently, using e.g. increasing time intervals. An alarm should be sent to the O&M system if a communication link goes down. It shall be possible to release/cancel CDR packets from CGFs and unacknowledged sequence numbers from GSNs by O&M operations if permanent GSN-CGF link failures would occur. The buffers containing Sequence Numbers of potentially duplicated packets and the buffers containing the numbers of unacknowledged CDR packets shall be kept up to date (with CDR packet transfers) using atomic transaction mechanisms. If the GSN-CGF1 communication link is down, any new CDRs generated by the GSN are sent to a properly working CGF2, instead of the CGF1.

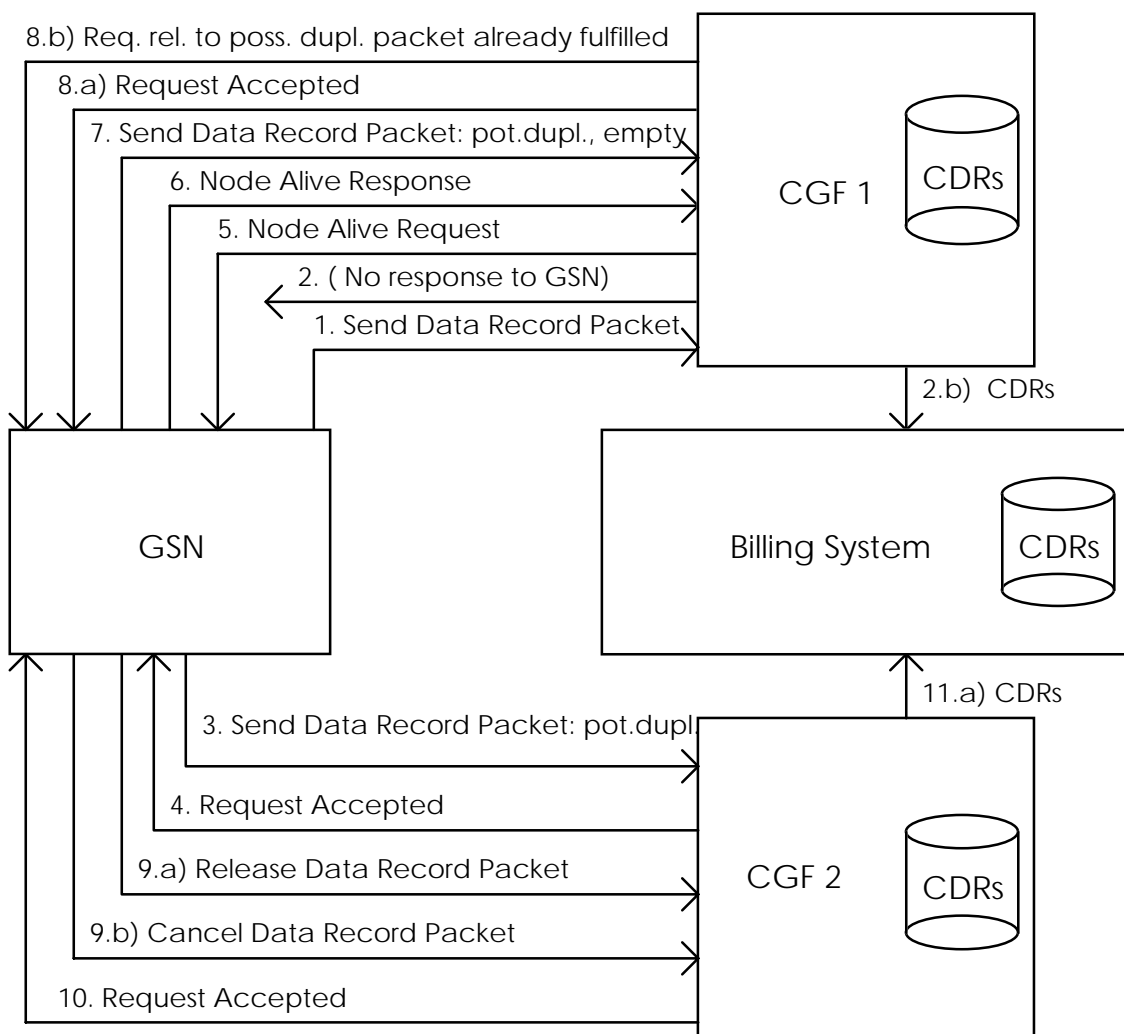

Figure 14: General CGF redundancy messaging scheme

A more detailed description of the CGF redundancy mechanism:

Due to a network failure or node failure, a CGF might not send a response within the configured timeout period to a request it got from a GSN. As a first attempt, retries of requests are to be used as defined in 09.60, if the response is not received in the configured time.

If a CDR generating node loses its connection to the CGF unexpectedly, it may send the CDRs to the next CGF in the priority list. If the CGF changes, the GSN can continue sending CDRs to different CGF nodes, depending on which CGF has been configured as the receiver of CDRs for a particular PDP context.

Sequence number buffers: The GSN might lose its connection to its primary CGF due to a link failure or CGF going down. In this kind of redundancy condition the GSN attempts to redirect the CDR traffic to a secondary CGF (after possible retries have failed). The GSN maintains an internal buffer for Sequence Numbers of requests not yet

successfully responded by the primary CGF, for the case that it may become capable of communicating to the primary CGF at a later date. The GSN will send the not responded Data Record Packets (DRPs) to the secondary CGF, and the GSN maintains also a buffer for the Sequence Numbers related to those DRPs that have been temporarily stored to this secondary CGF. (If the communication towards the secondary CGF would not work, the transfer of possibly duplicated DRPs and Sequence Number bookkeeping would be done for a tertiary CGF etc.) Also the CGFs maintain Sequence Number buffers for each of their GSN links. The Sequence Numbers may in future be needed in relation to the possibly duplicated CDRs that the CGFs have got from the GSN(s). The Sequence Numbers are stored to wait for a final decision to release them towards the BS (if the primary CGF had not received successfully the packets originally sent by a GSN) or to cancel them (if the primary CGF had received and processed successfully the originally by GSN sent packets).

The GSN is able to cancel (or release for transfer towards the BS) CDR packets sent to a secondary CGF if the primary CGF becomes available for service. To make the right decision the GSN first sends an empty test packet with the 'Send possibly duplicated Data Record Packet' Packet Transfer Command to the primary CGF, using a previously not responded Sequence Number.

In case that the empty test packet to the primary CGF which was temporarily down (or to which the link was down) is responded with the Cause value "Request Accepted", the GSN will release the corresponding CDRs waiting for final decision in the secondary CGF, towards the Billing System with the Packet Transfer Command 'Release Data Record Packet'.

If the primary CGF responses this test message with the Cause value "Request related to possibly duplicated packets already fulfilled", the GSN will cancel the corresponding CDRs waiting for final decision in the secondary CGF, using the Packet Transfer Command 'Cancel Data Record Packet'.

To enable that a GSN failure (destroying its Sequence Number buffers per each CGF link for non-responded requests or possibly duplicated packets) would not cause CDR packets to stay forever in the temporary decision waiting buffers of CGFs, there should also be O&M means of emptying those CGF buffers.

There shall be a also configurable parameter in the CGF for making the final decision as to whether or not it is able to send the CDRs to the billing system for the case where the backup buffering mechanism in the GSN could not be used until the end of the messaging sequence related to a certain CDR packet has completed. This way the operator can:

- A) Select that the GSNs and CGFs take care of duplicate prevention and the BS is not required to do duplicate checking due to possible duplicates caused by GPRS node redundancy.
- B) Select that BS performs the duplicate prevention. To do this in the most effective way, the CGF may include an additional flag linked to possibly duplicated CDRs sent to Billing System, that they have not been released by a GSN for BS use (or use special kind of file name if a file protocol is used between CGF and BS). This means that the BS has somewhat more processing work to do, but the BS would anyway get a duplicate free end result. CGF is in this case always authorised to forward CDRs towards the BS, also when they contain possibly duplicated data. For this case the CGFs may also have a configurable flag that Data Record Packet Cancel/Release operations are not needed.

7.3.4.5.2 Information Elements in Data Record Transfer Request

Table 16: Information elements in a Data Record Transfer Request

Information element	Presence requirement
Packet Transfer Command	Mandatory
Data Record Packet	Conditional
Sequence Numbers of Released Packets	Conditional
Sequence Numbers of Cancelled Packets	Conditional
Private Extension	Optional

7.3.4.5.3 Packet Transfer Command IE

The value of the Packet Transfer Command in its information element tells the nature of the message:

1 = 'Send Data Record Packet'

2 = 'Send possibly duplicated Data Record Packet'

- 3 = 'Cancel Data Record Packet'
- 4 = 'Release Data Record Packet'

The following describes the usage of each Packet Transfer Command.

- 1) Send Data Record Packet. This is used for the normal CDR sending, and it is the usual Packet Transfer Command, other commands being used only in error recovery cases. Of the conditional IE's, the "Data Record Packet" is present in the message.
- 2) Send possibly duplicated Data Record Packet. When the CDR packet is directed to a secondary CGF (by a CDR generating node) because the currently used CGF not working or the CDR transfer is not working properly, then this Packet Transfer Command is used instead of the normal 'Send Data Record Packet'. Of the conditional IEs, the Data Record Packet" is present in the message, when sending the message to a CGF acting as temporary storage, when the original primary CGF could not be contacted.
- 3) Cancel Data Record Packet. Of the conditional IE's, the "Sequence Numbers of Cancelled Packets" is present in the message.
- 4) Release Data Record Packet. Of the conditional IE's, the "Sequence Numbers of Released Packets" is present in the message.

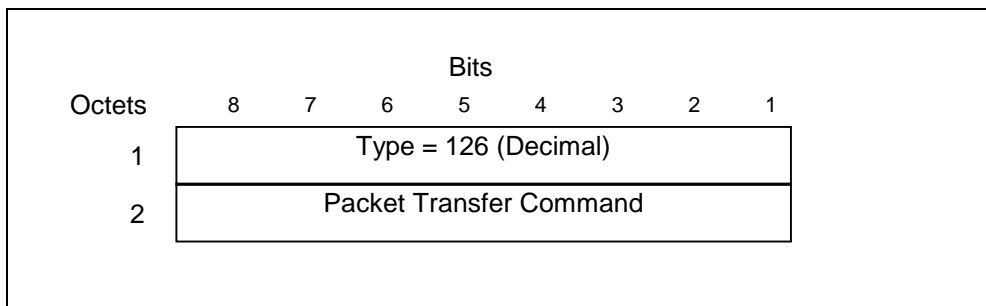

Figure 15: Packet Transfer Command information element

After the CGF has received the Packet Transfer Command 'Release Data Record Packet' with the Sequence Number(s) for earlier sent 'Send possibly duplicated Data Record Packet' command(s), it can consider itself authorised to send the Data Record Packets previously marked as possibly duplicated towards the Billing System as normal (not duplicated) CDRs.

7.3.4.5.4 Data Record Packet IE

The Data Record Packet element, which is present conditionally if the Packet Transfer Command is 'Send Data Record Packet' or 'Send possibly duplicated Data Record Packet', may contain one or more data records. The format of the records is ASN.1 or another format, identified by the Data Record Format. The Data Record Format Version numbering starts from 1.

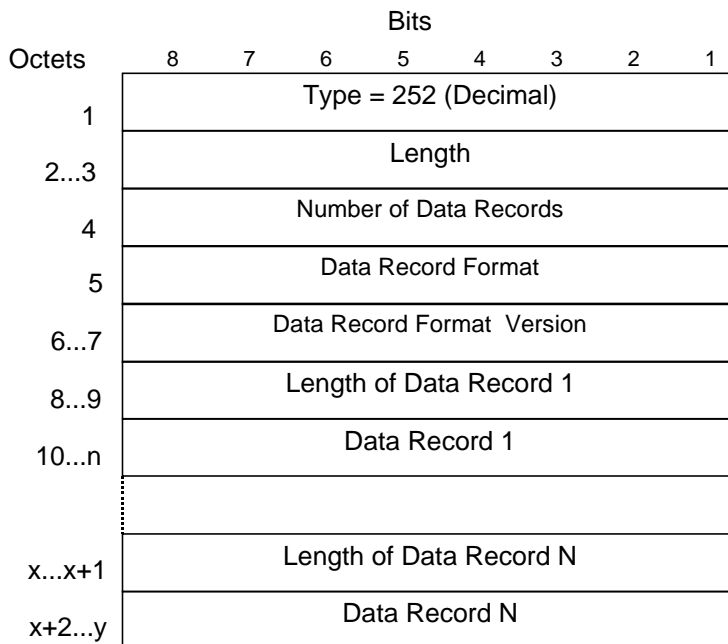

Figure 16: Data Record Packet information element

7.3.4.5.5 Sequence Numbers of Released Packets IE

The Sequence Numbers of Released Packets is present if the Packet Transfer Command is ‘Cancel Data Record Packet’. The format of the information element is described below:

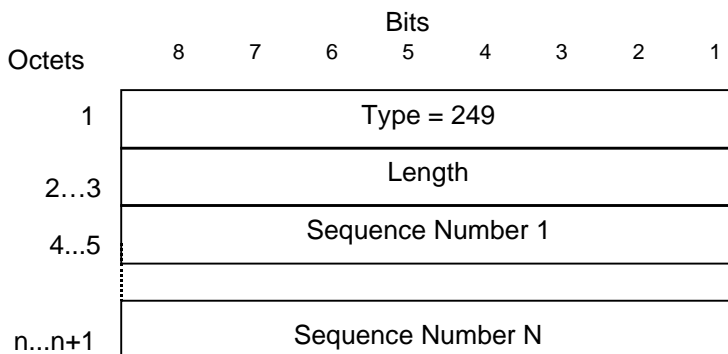

Figure 17: Sequence Numbers of Released Packets information element

7.3.4.5.6 Sequence Numbers of Cancelled Packets IE

The Sequence Numbers of Cancelled Packets information element contains the IE Type, Length and the Sequence Number(s) (each 2 octets) of the cancelled Data Record Transfer Request(s). It is present if the Packet Transfer Command is ‘Cancel Data Record Packet’.

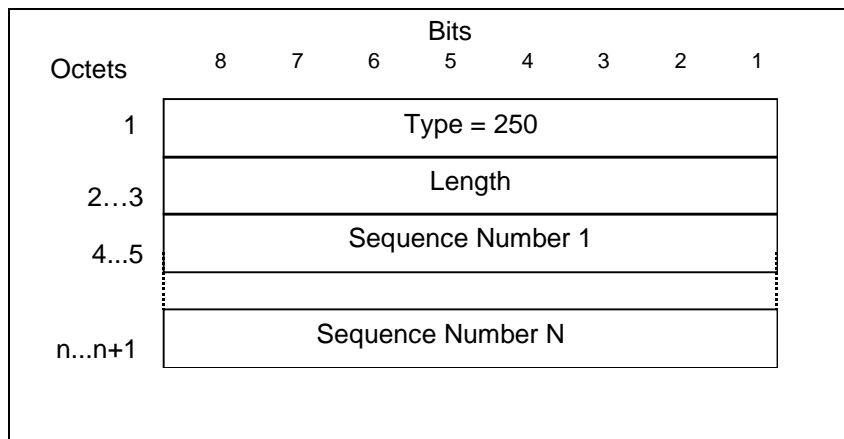

Figure 18: Sequence Numbers of Cancelled Packets information element

7.3.4.5.7 Private Extension IE

The optional Private Extension contains vendor or operator specific information.

7.3.4.6 Data Record Transfer Response

The message shall be sent as a response of a received Data Record Transfer Request. Also, several Data Record Transfer Requests can be responded by a single Data Record Transfer Response.

Table 17: Information elements in a Data Record Transfer Response

Information element	Presence requirement
Cause	Mandatory
Requests Responded	Mandatory
Private Extension	Optional

The Cause value is the same (whatever the value) for all those messages responded by that particular Response.

Possible Cause values are:

- "Request Accepted"
- "No resources available"
- "Service not supported"
- "System failure"
- "Mandatory IE incorrect"
- "Mandatory IE missing"
- "Optional IE incorrect"
- "Invalid message format"
- "Version not supported"
- "Request not fulfilled"
- "Request already fulfilled "
- "Request related to possibly duplicated packet already fulfilled"

The Requests Responded information element contains the IE Type, Length and the Sequence Numbers (each 2 octets) of the Data Record Transfer Requests.

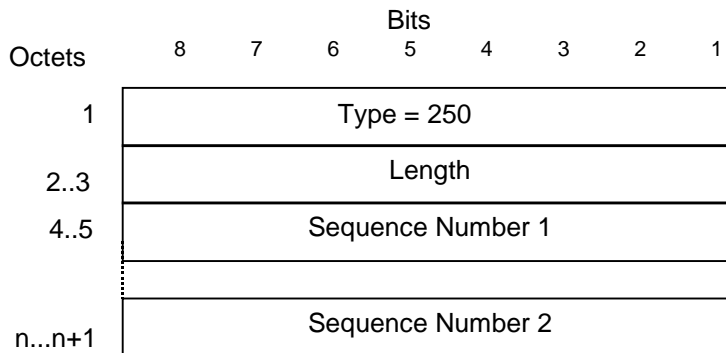

Figure 19: Requests Responded information element

The optional Private Extension contains vendor or operator specific information.

Depending on the Cause value severity and general occurrence frequency, the node that sent the corresponding Data Record Transfer Request, may start to direct its CDRs to another CGF.

7.3.4.7 Examples of GTP' messaging cases

The following example cases represent the three different key Data Record Transfer Request/Response messaging related CDR packet handling schemes:

Case 1): The normal CDR packet transfer:

GSN sends successfully a CDR packet to the CGF, and since the GSN gets a response (Request Accepted) for the Data Record Transfer Request, there is no need to revert to the CGF redundancy mechanism and redirect the CDR packet traffic flow to an other CGF.

Case 2): The GSN-CGF1 connection breaks before a successful CDR reception:

In this example case the CDR packet sent by the GSN is lost before it is received by the CGF1. (The loss might be caused by a link failure or e.g. a major CGF1 failure.)

Case 3): The GSN-CGF1 connection breaks after a successful CDR reception:

In this example case the CDR packet sent by the GSN is received correctly by the CGF1 and moved to its non-volatile memory (or even to the next NE in the communication chain). Anyhow, the GSN-CGF1 communication stops in this example case working before the GSN gets the positive response (Data Record Transfer Response: Request Accepted) that would acknowledge that the CDR packet was successfully received by CGF1.

The next three subclauses describe in more detail each of the key Data Record Transfer Request/Response messaging schemes.

7.3.4.7.1 Case 1: The normal CDR packet transfer

The following Figure represents the default mode of CDR transfer from the CDR generating entities (GSNs) to the CDR packet collecting entities (CGFs).

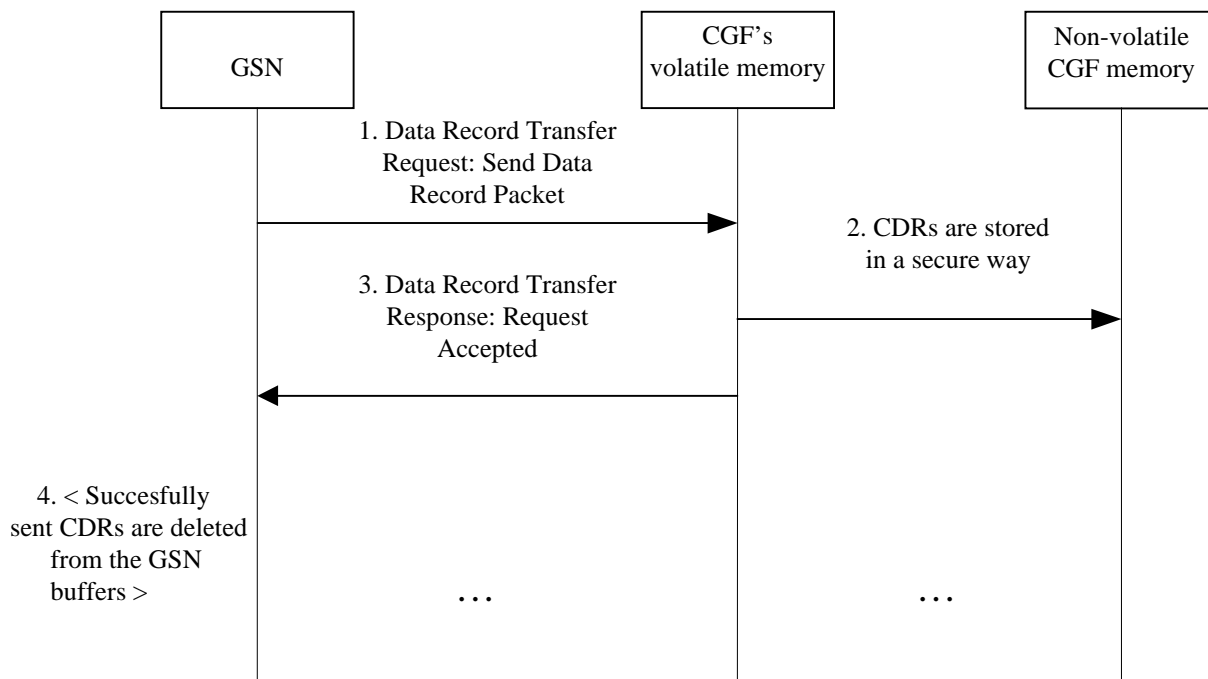

Figure 20: A normal CDR transfer process between a GSN and CGF

- 1) The CDR generating entity (here the GSN symbolises either SGSN or GGSN) sends CDR(s) in a packet to CGF (that is the current primary Charging Gateway Functionality for the specific CDR generating node, "CGF1"). The sending is performed by using the Data Record Transfer Request message, with the Packet Transfer Command IE having the value 'Send Data Record Packet'.
- 2) The CGF opens the received message and stores the packet contents in a safe way (to e.g. a redundant RAM memory unit or a mirrored non-volatile memory or even to another node).
- 3) The CDR receiving entity (CGF) sends confirmation of the successful packet reception to the CDR generating node (GSN). The confirmation is performed by using the Data Record Transfer Response message, with the Cause value being 'Request Accepted'.
- 4) After the positive response 'Request Accepted' is received by the GSN, it may delete the successfully sent CDRs from its send buffer.

The general principle of GTP' to retransmit the request if the response has not been received within a configurable time-out limit, is also followed here in point 1). The maximum amount of retries is a configurable value.

7.3.4.7.2 Case 2: The GSN-CGF1 connection breaks before a successful CDR reception

The following Figure describes the exceptional case when the CDR transfer from a CDR generating entity (GSN) to the primary CDR packet collecting entity (CGF1) fails in a way that the CGF1 is not able to store the CDR packet sent by the GSN. (The reason for the failure in packet transfer may be e.g. a link failure between the GSN and CGF1, or a capacity exhausting error in the storage device of CGF1, or a general CGF1 system failure or CGF1 maintenance break.)

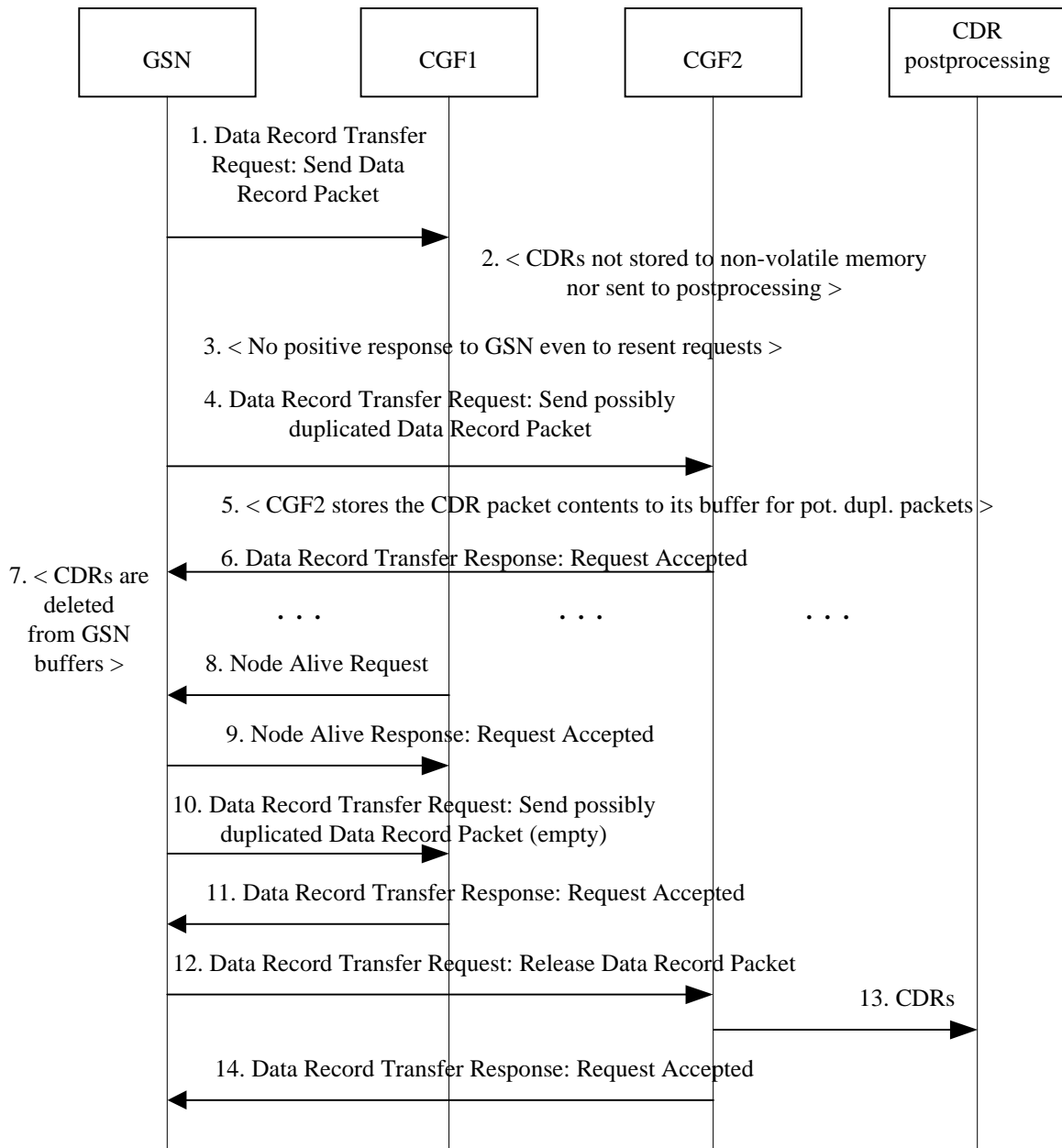

Figure 21: Duplicate prevention case: CDR sending via CGF1 had not succeeded

- 1) The CDR generating entity (GSN) sends CDR(s) in a packet to CGF (that is the current primary Charging Gateway Functionality for the specific CDR generating node, "CGF1"). The sending is performed by using the Data Record Transfer Request message, with the Packet Transfer Command IE having the value 'Send Data Record Packet'.
- 2) Due to a failure in the GSN-CGF1 communication link of CGF1, the CGF1 is not able to store the packet sent by the GSN in a safe way (to e.g. a redundant RAM memory unit or a mirrored non-volatile memory or to another node).

- 3) Therefore the GSN is not able to get a response (or it could alternatively get a negative response like "No resources available" as the Cause value in the Data Record Transfer Response message).
- 4) (The GSN may now first test the GSN-CGF2 link by a Echo Request message, that the CGF2 would respond by the Echo Response.) Then the GSN sends the same CDR packet that could not be sent to CGF1 to the next CGF in its CGF preference list (here CGF2) using the Data Record Transfer Request message, with the Packet Transfer Command IE having the value 'Send possible duplicated Data Record Packet'.
- 5) As the connection to the CGF2 is working, the CGF2 is able to process the CDR packet. Since the packet was marked by the sending GSN to be potentially duplicated, it is stored into the CGF2, but not yet sent forward towards the Billing System.
- 6) The CGF2 sends confirmation of the successful packet reception to the GSN. The confirmation is performed by using the Data Record Transfer Response message, with the Cause value being 'Request Accepted'
- 7) The GSN can now delete the now successfully sent (potentially duplicated) CDRs from its CDR buffer (but it keeps the sequence number(s) of the sent potentially duplicated packet(s) in a buffer dedicated for that.
- 8) When CGF1 is recovering after a system reboot, it sends a Node Alive Request message to the configured peer GSN(s), and so the GSN notices that it can again successfully communicate with the CGF1. (The GSN may also detect this by using the Echo Request messages, which would be answered by CGF1 by the Echo Response message.)
- 9) GSN acknowledges the CGF1 by Node Alive Response message.
- 10) For the earlier unacknowledged Data Record Transfer Request message(s), the GSN sends CGF1 empty test packet(s) (with no CDR payload in the Data Record Packet IE but just the other parts of the message frame).
- 11) CGF1 responds with Data Record Transfer Response message, with the Cause value being 'Request Accepted', because in this example case CGF1 had lost the communication capability towards GSN before storing the previously received (and by CGF1 unacknowledged) CDR packet.
- 12) Now GSN knows that the CGF1 had not originally been able to process and forward the original version of the CDR packet from the GSN, and it indicates CGF2 that CGF2 can send the CDR packet(s) related to the previously unacknowledged GTP' Sequence Number(s) to post-processing. Those packets' Sequence Numbers are indicated in the Sequence Numbers of the Released Packets IE.
- 13) CGF2 shall now be able to send the released packets towards post-processing.
- 14) CGF2 responds with Data Record Transfer Response message, with the Cause value being 'Request Accepted'.

After all the potentially duplicated packets are cleared from CGF(s), the GSN can continue in normal way the transfer of CDRs.

7.3.4.7.3 Case 3: The GSN-CGF1 connection breaks after a successful CDR reception

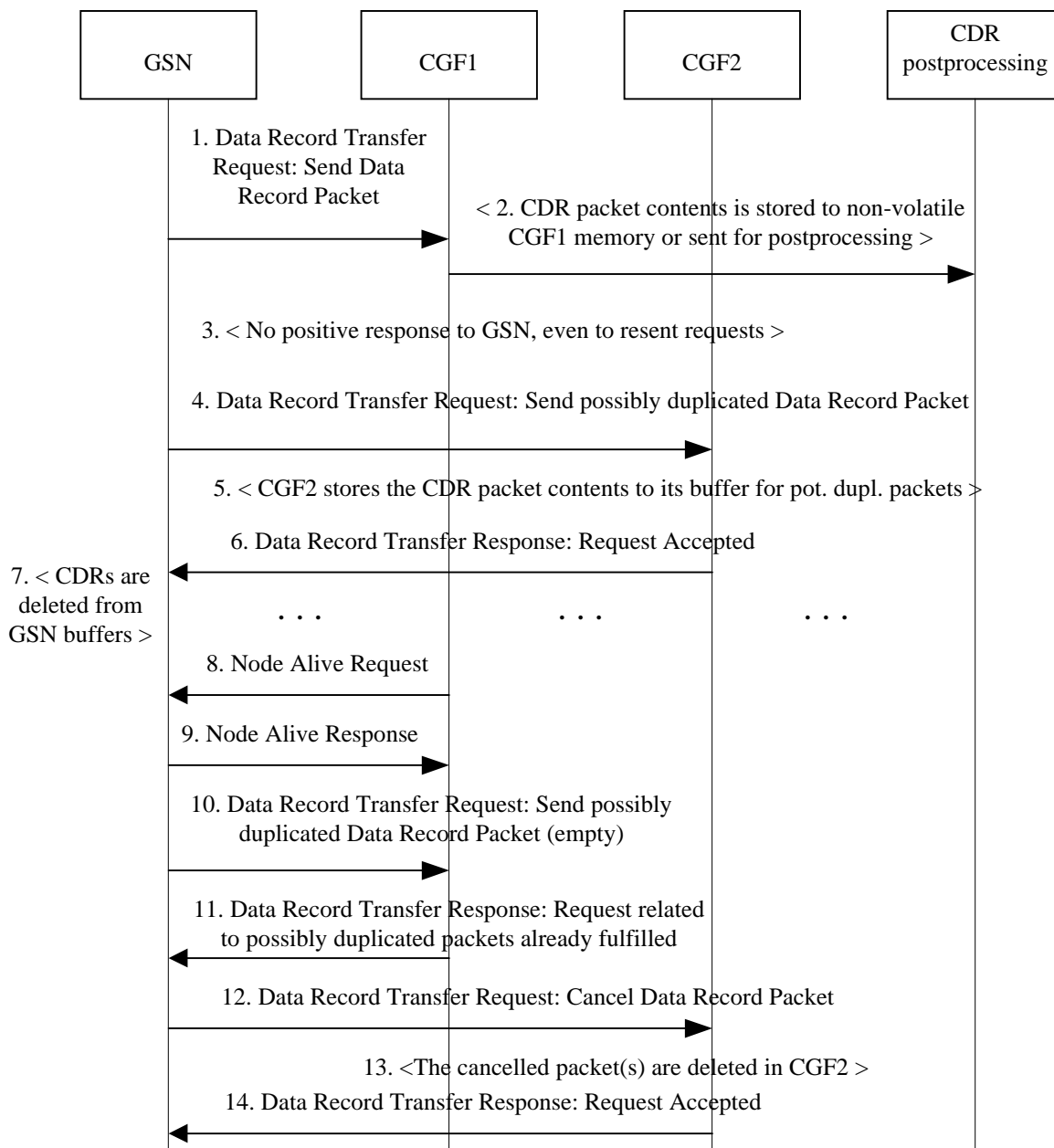

Figure 22: Duplicate prevention case: CDR sending via CGF1 had succeeded

- 1) The CDR generating entity (GSN) sends CDR(s) in a packet to CGF (that is the current primary Charging Gateway Functionality for the specific CDR generating node, "CGF1"). The sending is performed by using the Data Record Transfer Request message, with the Packet Transfer Command IE having the value 'Send Data Record Packet'.
- 2) The CGF1 is able to store the packet sent by the GSN in a safe way (to e.g. a redundant RAM memory unit or a mirrored non-volatile memory or to another node).

- 3) Since the GSN-CGF1 communication connection is now broken, the GSN is not able to get the response "Request Accepted" as the Cause value in the Data Record Transfer Response message.
- 4) Then the GSN sends the same CDR packet that could not be sent to CGF1 to the next CGF in its CGF preference list (here CGF2) a Data Record Transfer Request message, with the Packet Transfer Command IE having the value 'Send possible duplicated Data Record Packet'. (That sending may be preceded by the testing of the GSN-CGF2 link by a Echo Request message, that the CGF2 would respond by the Echo Response.)
- 5) As the connection to CGF2 is working, CGF2 is able to process the CDR packet. Since the packet was marked by the sending GSN to be potentially duplicated, it is stored in CGF2, but not yet sent forward towards the post processing or Billing System.
- 6) The CGF2 sends confirmation of the successful packet reception to the GSN. The confirmation is performed by using the Data Record Transfer Response message, with the Cause value being 'Request Accepted'
- 7) The GSN can now delete the now successfully sent (potentially duplicated) CDRs from its CDR buffer (but it keeps the sequence number(s) of the sent potentially duplicated packet(s) in a buffer dedicated for that.
- 8) When CGF1 is recovering after a system reboot, it sends a Node Alive Request message to the configured peer GSN(s), and so the GSN notices that it can again successfully communicate with the CGF1. (The GSN may also detect this by using the Echo Request messages, which would be answered by CGF1 by the Echo Response message.)
- 9) GSN acknowledges the CGF1 by Node Alive Response message.
- 10) For the earlier unacknowledged Data Record Transfer Request message(s), the GSN sends CGF1 empty test packet(s) (with no CDR payload in the Data Record Packet IE but just the other parts of the message frame).
- 11) CGF1 responds with Data Record Transfer Response message, with the Cause value being 'Request related to possibly duplicated packets already fulfilled', because in this example case CGF1 had lost the communication capability towards GSN after storing the previously received (and by CGF1 unacknowledged) CDR packet.
- 12) Now GSN knows that the CGF1 had originally been able to process and forward the original version of the CDR packet from the GSN, and it indicates CGF2 that CGF2 can cancel the CDR packet(s) related to the previously unacknowledged GTP' GSN-CGF1 Sequence Number(s). Those packets' Sequence Numbers are indicated in the Sequence Numbers of the Cancelled Packets IE.
- 13) CGF2 shall now delete the cancelled packet(s) from its buffer for potentially duplicated packets.
- 14) CGF2 responds with Data Record Transfer Response message, with the Cause value being 'Request Accepted'.

After all the potentially duplicated packets are cleared from CGF(s), the GSN can continue in normal way the transfer of CDRs.

7.4 Data Record Formats used in GTP'

The format of the CDRs sent between the GPRS network elements that generate the CDRs and the CGF are defined by the Data Record Format of Data Record Packet information element. In addition to 1 standard format (ASN.1), there are private formats.

7.4.1 ASN.1 format

See clause 8 and the ASN.1 language descriptions for the definitions. BER (Basic Encoding Rules) provides the transfer syntax for abstract syntax defined in ASN.1. The Data Record Format code for ASN.1 is 1.

7.4.2 Other formats

The physical CDR format can also be a private one. The Data Record Format identifiers 11...50 (decimal) are reserved for private (implementation specific) use.

7.5 CGF - BS Protocol Interface

7.5.1 The transfer protocols at CGF - BS interface

This document gives several recommendations for the main protocol layers for the Charging Gateway Functionality - Billing System interface protocol stack. These recommendations are not strictly specified features, since there are a lot of variations among the existing Billing Systems. The recommendations are FTAM protocol on X.25 or TCP/IP, and FTP over TCP/IP.

7.5.2 The format of the CDRs at CGF - BS interface

The contents of the CDRs sent between the CGF and the Billing System are defined by the ASN.1 language in the GPRS charging specifications. Other CDR contents or formats are possible if the CGF provides processing functionality for the CDRs.

8 Charging Data Record Structure

8.1 ASN.1 definitions for CDR information

Within the current GSM 12-series of specifications the ASN.1 definitions are based on X.208 [40] which has been superseded by X.680. This newer version not only includes new features but also removes some that were present in X.208. It was agreed that where possible, the GPRS work would be based on those ASN.1 features that were common to both. However, where necessary, the new features in X.680 [41] be used in some places. X.208 [40] feature that are no longer in X.680 [41] will not be used.

Changes (enhancements) in GSM1205-DataTypes:

```
CallEventRecordType ::= INTEGER
{
```

```
  moCallRecord      (0),
  mtCallRecord      (1),
  roamingRecord     (2),
  incGatewayRecord  (3),
  outGatewayRecord  (4),
  transitCallRecord (5),
  moSMSRecord       (6),
  mtSMSRecord       (7),
  moSMSIWRecord     (8),
  mtSMSGWRecord     (9),
  ssActionRecord    (10),
  hlrIntRecord      (11),
  locUpdateHLRRecord (12),
  locUpdateVLRRecord (13),
  commonEquipRecord (14),
  moTraceRecord     (15),
  mtTraceRecord     (16),
  termCAMELIntRecord (17),
  sgsnPDPRecord     (18),
  ggsnPDPRecord     (19),
  sgsnMMRecord      (20),
  sgsnSMORecord     (21),
  sgsnSMTRRecord    (22)
```

```
}
GPRS_Charging-DataTypes {... }
```

```
DEFINITIONS IMPLICIT TAGS ::=
```

```
BEGIN
```

```
-- EXPORTS everything
```

```
IMPORTS
```

```
CellId, Diagnostics, CallDuration, ManagementExtensions, TimeStamp, MSISDN, LocationAreaCode,
MessageReference, RecordingEntity, SMSResult
FROM GSM1205-DataTypes{ ccitt (0) identified-organization (4) etsi(0) mobileDomain (0) gsmOperation-
Maintenance (3) moduleId (3) gsm-12-05 (5) InformationModel (0) asn1Module (2) 1 }
```

```
AddressString, ISDN-AddressString, IMSI, IMEI
FROM MAP-CommonDataTypes { ccitt identified-organization (4) etsi(0) mobileDomain (0) gsmNetworkId
(1) moduleId (3) map-CommonDataTypes (18) version2 (2) }
```

```
ObjectInstance
FROM CMIP-1 {joint-iso-ccitt ms(9) cmip(1) version1 (1) protocol (3)}
```

```
ManagementExtension
FROM Attribute-ASN1Module {joint-iso-ccitt ms(9) smi(3) part2 (2) asn1Module(2) 1}
```

```
AE-title
FROM ACSE-1 {joint-iso-ccitt association-control(2) abstract-syntax(1) apdus(0) version(1) };
--
```

```
-- Note that the syntax of AE-title to be used is from
-- CCITT Rec. X.227 / ISO 8650 corrigendum and not "ANY"
--
```

```
-----
-- CALL AND EVENT RECORDS
--
-----
```

```
CallEventRecord ::= CHOICE
```

```
{
  sgsnPDPRecord          [0] SGSNPDPRecord,
  ggsnPDPRecord          [1] GGSNPDPRecord,
  sgsnMMRecord           [2] SGSNMMRecord,
  sgsnSMORRecord         [3] SGSNSMORRecord,
  sgsnSMTRRecord         [4] SGSNSMTRRecord
}
```

```
GGSNPDPRecord ::= SET
```

```
{
  recordType              [0] CallEventRecordType,
  networkInitiation       [1] NetworkInitiatedPDPContext OPTIONAL,
  anonymousAccessIndicator [2] BOOLEAN OPTIONAL,
  subSystemType         [2] SubSystemType CONDITIONAL,
  servedIMSI              [3] IMSI,
  ggsnAddress              [4] GSNAddress,
  chargingID              [5] ChargingID,
  sgsnAddress              [6] SEQUENCE OF GSNAddress,
  accessPointNameNI       [7] AccessPointNameNI,
  pdpType                  [8] PDPType,
  servedPDPAddress         [9] PDPAddress,
  remotePDPAddress     [10] SEQUENCE OF PDPAddress OPTIONAL,
  dynamicAddressFlag       [11] DynamicAddressFlag OPTIONAL,
  listOfTrafficVolumes     [12] SEQUENCE OF ChangeOfCharCondition,
  recordOpeningTime        [13] TimeStamp,
  duration                 [14] CallDuration,
  causeForRecClosing       [15] CauseForRecClosing,
  diagnostics              [16] Diagnostics OPTIONAL,
  recordSequenceNumber     [17] INTEGER OPTIONAL,
  nodeID                   [18] NodeID OPTIONAL,
  recordExtensions         [19] ManagementExtensions OPTIONAL,
  localSequenceNumber      [20] LocalSequenceNumber OPTIONAL,
  apnSelectionMode         [21] APNSelectionMode,
  servedMSISDN             [22] MSISDN OPTIONAL,
  chargingCharacteristics   [23] ChargingCharacteristics CONDITIONAL OPTIONAL,
  systemType               [24] SystemType OPTIONAL
}
```

```
SGSNMMRecord ::= SET
```

```
{
  recordType              [0] CallEventRecordType,
  servedIMSI              [1] IMSI,
  servedIMEI              [2] IMEI OPTIONAL,
  sgsnAddress              [3] GSNAddress,
  msNetworkCapability      [4] MSNetworkCapability OPTIONAL,
  routingArea              [5] RoutingAreaCode OPTIONAL,
  locationAreaCode         [6] LocationAreaCode OPTIONAL,
  cellIdentity             [7] CellId OPTIONAL,
  changeLocation           [8] SEQUENCE OF ChangeLocation OPTIONAL,
  recordOpeningTime        [9] TimeStamp,
  duration                 [10] CallDuration OPTIONAL,
  sgsnChange               [11] SGSNChange OPTIONAL,
  causeForRecClosing       [12] CauseForRecClosing,
  diagnostics              [13] Diagnostics OPTIONAL,
  recordSequenceNumber     [14] INTEGER OPTIONAL,
  nodeID                   [15] NodeID OPTIONAL,
  recordExtensions         [16] ManagementExtensions OPTIONAL,
}
```

```

    localSequenceNumber [17] LocalSequenceNumber OPTIONAL,
    servedMSISDN [18] MSISDN OPTIONAL,
    chargingCharacteristics [22] ChargingCharacteristics CONDITIONALOPTIONAL,
    subSystemType [23] SubSystemType CONDITIONALOPTIONAL
}

```

```

SGSNPDPRecord ::= SET
{
    recordType [0] CallEventRecordType,
    networkInitiation [1] NetworkInitiatedPDPContext OPTIONAL,
    anonymousAccessIndicator [2] BOOLEAN OPTIONAL,
    subSystemType [2] SubSystemType CONDITIONAL,
    servedIMSI [3] IMSI,
    servedIMEI [4] IMEI OPTIONAL,
    sgsnAddress [5] GSNAddress,
    msNetworkCapability [6] MSNetworkCapability OPTIONAL,
    routingArea [7] RoutingAreaCode OPTIONAL,
    locationAreaCode [8] LocationAreaCode OPTIONAL,
    cellIdentity [9] CellId OPTIONAL,
    chargingID [10] ChargingID,
    ggsnAddressUsed [11] GSNAddress,
    accessPointNameNI [12] AccessPointNameNI,
    pdpType [13] PDPType,
    servedPDPAddress [14] PDPAddress,
    listOfTrafficVolumes [15] SEQUENCE OF ChangeOfCharCondition,
    recordOpeningTime [16] TimeStamp,
    duration [17] CallDuration,
    sgsnChange [18] SGSNChange OPTIONAL,
    causeForRecClosing [19] CauseForRecClosing,
    diagnostics [20] Diagnostics OPTIONAL,
    recordSequenceNumber [21] INTEGER OPTIONAL,
    nodeID [22] NodeID OPTIONAL,
    recordExtensions [23] ManagementExtensions OPTIONAL,
    localSequenceNumber [24] LocalSequenceNumber OPTIONAL,
    apnSelectionMode [25] APNSelectionMode,
    accessPointNameOI [26] AccessPointNameOI,
    servedMSISDN [27] MSISDN OPTIONAL,
    chargingCharacteristics [28] ChargingCharacteristics CONDITIONALOPTIONAL,
    systemType [29] SystemType OPTIONAL
}

```

```

SGSNSMORecord ::= SET
{
    recordType [0] CallEventRecordType,
    servedIMSI [1] IMSI,
    servedIMEI [2] IMEI OPTIONAL,
    servedMSISDN [3] MSISDN OPTIONAL,
    msNetworkCapability [4] MSNetworkCapability,
    serviceCentre [5] AddressString,
    recordingEntity [6] RecordingEntity,
    locationArea [7] LocationAreaCode OPTIONAL,
    routingArea [8] RoutingAreaCode OPTIONAL,
    cellIdentity [9] CellId OPTIONAL,
    messageReference [10] MessageReference,
    originationTime [11] TimeStamp,
    smsResult [12] SMSResult OPTIONAL,
    recordExtensions [13] ManagementExtensions OPTIONAL,
    nodeID [14] NodeID OPTIONAL,
    localSequenceNumber [15] LocalSequenceNumber OPTIONAL,
    chargingCharacteristics [16] ChargingCharacteristics CONDITIONALOPTIONAL,
    subSystemType [17] SubSystemType CONDITIONALOPTIONAL
}

```

```

SGSNSMTRecord ::= SET
{
    recordType [0] CallEventRecordType,
    servedIMSI [1] IMSI,
    servedIMEI [2] IMEI OPTIONAL,
    servedMSISDN [3] MSISDN OPTIONAL,
    msNetworkCapability [4] MSNetworkCapability,
    serviceCentre [5] AddressString,
    recordingEntity [6] RecordingEntity,
    locationArea [7] LocationAreaCode OPTIONAL,
    routingArea [8] RoutingAreaCode OPTIONAL,
    cellIdentity [9] CellId OPTIONAL,
    originationTime [10] TimeStamp,
    smsResult [11] SMSResult OPTIONAL,
    recordExtensions [12] ManagementExtensions OPTIONAL,
    nodeID [13] NodeID OPTIONAL,
    localSequenceNumber [14] LocalSequenceNumber OPTIONAL,
    chargingCharacteristics [15] ChargingCharacteristics CONDITIONALOPTIONAL,
    subSystemType [16] SubSystemType CONDITIONALOPTIONAL
}

```

```

}

-----
--
-- OBJECT IDENTIFIERS
--
-----

gsm1205InformationModel OBJECT IDENTIFIER ::=
  { ccitt (0) identified-organization (4) etsi (0) mobileDomain (0)
    gsm-Operation-Maintenance (3) gsm-12-05 (5) informationModel (0) }

gsm1205ASN1Module OBJECT IDENTIFIER ::=
  { gsm1205InformationModel asn1Module(2) }

gsm1205ManagedObjectClass OBJECT IDENTIFIER ::=
  { gsm1205InformationModel managedObjectClass(3) }

gsm1205Package OBJECT IDENTIFIER ::=
  { gsm1205InformationModel package(4) }

gsm1205NameBinding OBJECT IDENTIFIER ::=
  { gsm1205InformationModel nameBinding(6) }

gsm1205Attribute OBJECT IDENTIFIER ::=
  { gsm1205InformationModel attribute(7) }

gsm1205Action OBJECT IDENTIFIER ::=
  { gsm1205InformationModel action(9) }

gsm1205Notification OBJECT IDENTIFIER ::=
  { gsm1205InformationModel notification(10) }

-----
--
-- COMMON DATA TYPES
--
-----

AccessPointNameNI ::= IA5String (SIZE(1..63))
--
-- Network Identifier part of APN in "dot" representation
-- see TS 23.003
--

AccessPointNameOI ::= IA5String (SIZE(1..37))
--
-- Operator Identifier part of APN in dot representation
-- see TS 23.003
--

APNSelectionMode ::= ENUMERATED
{
  --
  -- See Information Elements TS 29.060
  --
  MSorNetworkProvidedSubscriptionVerified (0),
  MSProvidedSubscriptionNotVerified (1),
  NetworkProvidedSubscriptionNotVerified (2)
}

CauseForRecClosing ::= INTEGER
{
  --
  -- in GGSN the value sGSNChange should be used for partial record
  -- generation due to SGSN Address List Overflow
  --
  -- cause codes 0 to 15 are defined in GSM12.05 as 'CauseForTerm' (cause for termination)
  --
  normalRelease (0),
  abnormalRelease (4),
  volumeLimit (16),
  timeLimit (17),
  sGSNChange (18),
  maxChangeCond (19),
  managementIntervention (20)
}

ChangeCondition ::= ENUMERATED
{
  qoSChange (0),
  tariffTime (1),
  recordClosure (2)
}

```

```

}
ChangeOfCharCondition ::= SEQUENCE
--
-- used in PDP context record only
--
{
    qosRequested          [1] QoSInformation OPTIONAL,
    qosNegotiated         [2] QoSInformation OPTIONAL,
    dataVolumeGPRSUplink  [3] DataVolumeGPRS,
    dataVolumeGPRSDownlink [4] DataVolumeGPRS,
    changeCondition       [5] ChangeCondition,
    changeTime            [6] TimeStamp
}

ChangeLocation ::= SEQUENCE
--
-- used in SGSNMMRecord only
--
{
    locationAreaCode      [0] LocationAreaCode,
    routingAreaCode       [1] RoutingAreaCode,
    cellId                [2] CellID OPTIONAL,
    changeTime            [3] TimeStamp
}

ChargingCharacteristics ::= OCTET STRING (SIZE(1))
--
-- Descriptions for the bits of the flag set:
--
-- Bit 1: H (Hot billing)          := '00000001'B
-- Bit 2: F (Flat rate)           := '00000010'B
-- Bit 3: P (Prepaid service)      := '00000100'B
-- Bit 4: N (Normal billing)       := '00001000'B
-- Bit 5: - (Reserved, set to 0)   := '00010000'B
-- Bit 6: - (Reserved, set to 0)   := '00100000'B
-- Bit 7: - (Reserved, set to 0)   := '01000000'B
-- Bit 8: - (Reserved, set to 0)   := '10000000'B
--

ChargingID ::= INTEGER (0..4294967295)
--
-- generated in GGSN, part of PDP context, see TS 23.060
-- 0..4294967295 is equivalent to 0..2**32-1

DataVolumeGPRS ::= INTEGER
--
-- The volume of uncompressed data transferred in octets.
--

DynamicAddressFlag ::= BOOLEAN

ETSIAddress ::= AddressString
--
--first octet for nature of address, and numbering plan indicator (3 for X.121)
--other octets TBCD
-- See TS 29.002
--

GSNAddress ::= IPAddress

GSMQoSInformation ::= SEQUENCE
{
    reliability          [0] QoSReliability,
    delay                [1] QoSDelay,
    precedence           [2] QoSPrecedence,
    peakThroughput       [3] QoSPeakThroughput,
    meanThroughput       [4] QoSMeanThroughput
}

IPAddress ::= CHOICE
{
    iPBinaryAddress      IPBinaryAddress,
    iPTextRepresentedAddress IPTextRepresentedAddress
}

IPBinaryAddress ::= CHOICE
{
    iPBinV4Address       [0] OCTET STRING (SIZE(4)),
    iPBinV6Address       [1] OCTET STRING (SIZE(16))
}

IPTextRepresentedAddress ::= CHOICE

```

```

{
  --
  -- IP address in the familiar "dot" notation
  --
  iPTextV4Address      [2] IA5String (SIZE(7..15)),
  iPTextV6Address      [3] IA5String (SIZE(15..45))
}

LocalSequenceNumber ::= INTEGER (0..4294967295)
  --
  -- Sequence number of the record in this node
  -- 0.. 4294967295 is equivalent to 0..2**32-1, unsigned integer in four octets

MSNetworkCapability ::= OCTET STRING (SIZE(1))

NetworkInitiatedPDPContext ::= BOOLEAN
  --
  -- Set to true if PDP context was initiated from network side
  --

NodeID ::= IA5 string (SIZE(1..20))

PDPAddress ::= CHOICE
{
  iPAddress      [0] IPAddress,
  eTSIAddress    [1] ETSIAddress
}

PDPTType ::= OCTET STRING (SIZE(2))
  --
  --OCTET 1: PDP Type Organization
  --OCTET 2: PDP Type Number
  -- See TS 29.060
  --

QoSAllocRetenPriority ::= ENUMERATED
{
  --
  -- See Quality of service TS 24.008
  --
  prioritySubscribed (0),
  priorityLevel 1 (1),
  priorityLevel 2 (2),
  priorityLevel 3 (3)
}

QoSDelay ::= ENUMERATED
{
  --
  -- See Quality of service TS 24.008
  --
  delayClass1 (0),
  delayClass2 (1),
  delayClass3 (2),
  delayClass4 (3)
}

QoSDeliveryOrder ::= ENUMERATED
{
  --
  -- See Quality of service TS 24.008
  --
  SubscribedDeliveryOrder (0),
  withDeliveryOrder (1),
  withoutDeliveryOrder (2)
}

QoSErroneousSDUs ::= ENUMERATED
{
  --
  -- See Quality of service TS 24.008
  --
  subscribed (0),
  noDetect (1),
  delivered (2),
  notDelivered (3)
}

QoSHandlingPriority ::= ENUMERATED
{
  --
  -- See Quality of service TS 24.008

```



```

--
-----
subscribed (0),
priorityLevel 1 (1),
priorityLevel 2 (2),
priorityLevel 3 (3)
}

QoSInformation ::= SEQUENCE
{
  reliability [0] QoSReliability,
  delay [1] QoSDelay,
  precedence [2] QoSPrecedence,
  peakThroughput [3] QoSPeakThroughput,
  meanThroughput [4] QoSMeanThroughput
}

QoSInformation ::= CHOICE
{
  gsmQoSInformation [0] GSMQoSInformation,
  umtsQoSInformation [1] UMTSQoSInformation
}

QoSMaxBitRate ::= OCTET STRING (SIZE(1))
--
-- See Quality of service TS 24.008--
--
-- In MS to network direction:
-- 0 0 0 0 0 0 0 0 Subscribed maximum bit rate for uplink
-- In network to MS direction:
-- 0 0 0 0 0 0 0 0 Reserved
-- In MS to network direction and in network to MS direction :
-- 0 0 0 0 0 0 0 1 The max bit rate is binary coded in 8 bits, using a granularity of 1 kbps
-- 0 0 1 1 1 1 1 1 giving a range of values from 1 kbps to 63 kbps in 1 kbps increments.
-- 0 1 0 0 0 0 0 0 MBR is 64 kbps+((the binary coded value in 8 bits -01000000)*8 kbps)
-- 0 1 1 1 1 1 1 1 giving a range of values from 64 kbps to 564 kbps in 8 kbps increments.
-- 1 0 0 0 0 0 0 0 MBR is 576 kbps + ((the binary coded value in 8 bits -10000000) * 64 kbps
-- 1 1 1 1 1 1 1 0 giving a range of values from 576 kbps to 8640 kbps in 64 kbps increments.
-- 1 1 1 1 1 1 1 1 Reserved

QoSMaxSDUsize ::= OCTET STRING (SIZE(1))
--
-- See Quality of service TS 24.008
--
-- The Maximum SDU size value is binary coded in 8 bits, using a granularity of 10 octets.
-- In MS to network direction:
-- 00000000 Subscribed maximum SDU size
-- 11111111 Reserved
-- In network to MS direction:
-- 00000000 Reserved
-- 11111111 Reserved
-- In MS to network direction and in network to MS direction :
-- For values in the range 00000001 to 10010110 the Maximum SDU size value is binary coded in 8
-- bits, using a granularity of 10 octets, giving a range of values from 10 octets to 1500 octets.
-- Values above 10010110 are as below:
-- 10010111 1502 octets
-- 10011000 1510 octets
-- 10011001 1520 octets

QoSMeanThroughput ::= ENUMERATED
{
  --
  -- See Quality of service TS 24.008
  --
  bestEffort (0),
  mean100octetPh (1),
  mean200octetPh (2),
  mean500octetPh (3),
  mean1000octetPh (4),
  mean2000octetPh (5),
  mean5000octetPh (6),
  mean10000octetPh (7),
  mean20000octetPh (8),
  mean50000octetPh (9),
  mean100000octetPh (10),
  mean200000octetPh (11),
  mean500000octetPh (12),
  mean1000000octetPh (13),
  mean2000000octetPh (14),
  mean5000000octetPh (15),
  mean10000000octetPh (16),
  mean20000000octetPh (17),
}

```

```

    mean50000000octetPh      (18)
}

QoSPeakThroughput ::= ENUMERATED
{
    --
    -- See Quality of service TS 24.008
    --
    unspecified                (0),
    upTo10000octetPs          (1),
    upTo20000octetPs          (2),
    upTo40000octetPs          (3),
    upTo80000octetPs          (4),
    upTo160000octetPs         (5),
    upTo320000octetPs         (6),
    upTo640000octetPs         (7),
    upTo1280000octetPs        (8),
    upTo2560000octetPs        (9)
}

QoSPrecedence ::= ENUMERATED
{
    --
    -- See Quality of service TS 24.008
    --
    unspecified                (0),
    highPriority                (1),
    normalPriority              (2),
    lowPriority                 (3)
}

QoSReliability ::= ENUMERATED
{
    --
    -- See Quality of service TS 24.008
    --
    unspecifiedReliability     (0),
    acknowledgedGTP           (1),
    unackGTPAcknowLLC         (2),
    unackGTPLLCAcknowRLC      (3),
    unackGTPLLCRLC            (4),
    unacknowUnprotectedData    (5)
}

QoSResidualBER ::= ENUMERATED
{
    --
    -- See Quality of service TS 24.008
    --
    -- The Residual BER value consists of 4 bits. The ranges from  $5 \cdot 10^{-2}$  to  $6 \cdot 10^{-8}$ . 4.
    5*10power2 (1),
    1*10power2 (2),
    5*10power3 (3),
    4*10power3 (4),
    1*10power3 (5),
    1*10power4 (6),
    1*10power5 (7),
    1*10power6 (8),
    6*10power8 (9)
}

QoSSDUErrrorRatio ::= ENUMERATED
{
    --
    -- See Quality of service TS 24.00
    --
    1*10power2 (1),
    7*10power3 (2),
    1*10power3 (3),
    1*10power4 (4),
    1*10power5 (5),
    1*10power6 (6)
}

QoSTrafficClass ::= ENUMERATED
{
    --
    -- See Quality of service TS 24.008
    --
    Subscribed (0),
    Conversational (1),
    Streaming (2),

```

```

    Interactive      (3),
    Background      (4)
}

QoSTransferDelay ::= OCTET STRING (SIZE(1))
{
    --
    -- See Quality of service TS 24.008
    --
    -- In MS to network direction:
    -- 0 0 0 0 0 0 Subscribed transfer delay
    -- In network to MS direction:
    -- 0 0 0 0 0 0 Reserved
    -- In MS to network direction and in network to MS direction :
    -- 0 0 0 0 0 1 The Transfer delay is binary coded in 6 bits, using a granularity of 10 ms
    -- 0 0 1 1 1 1 giving a range of values from 10 ms to 150 ms in 10 ms increments
    -- 0 1 0 0 0 0 transfer delay is 200 ms + ((the binary coded value in 6 bits - 010000)*50 ms)
    -- 0 1 1 1 1 1 giving a range of values from 200 ms to 950 ms in 50ms increments
    -- 1 0 0 0 0 0 transfer delay is 1000 ms + ((the binary coded value in 6 bits - 100000)*100 ms)
    -- 1 1 1 1 1 0 giving a range of values from 1000 ms to 4100 ms in 100ms increments
    -- 1 1 1 1 1 1 Reserved
}

RoutingAreaCode ::= OCTET STRING (SIZE(1))
    --
    -- See TS 24.008    --
    --

SGSNChange ::= BOOLEAN
    --
    -- present if first record after inter SGSN routing area update
    -- in new SGSN
    --

SubSystemType ::= ENUMERATED
{
    gsm (0),
    umtsRel99 (1)
}

UMTSQoSInformation ::= SEQUENCE
{
    trafficClass [0] QoSTrafficClass,
    maxBitRateUplink [1] QoSMaxBitRate,
    maxBitRateDownlink [2] QoSMaxBitRate,
    DeliveryOrder [3] QoSDeliveryOrder,
    maxSDUsize [4] QoSMaxSDUsize,
    sduErrorRatio [6] QoSSDUErrrorRatio,
    residualBER [7] QoSResidualBER,
    erroneousSDUs [8] QoSErroneousSDUs,
    transferDelay [9] QoSTransferDelay,
    handlingPriority [10] QoSHandlingpriority,
    allocRetenPriority [11] QoSAllocRetenPriority
}

```

Annex A (informative): Change history

Change history					
TSG SA#	Version	CR	Tdoc SA	New Version	Subject/Comment
S_06	-	-	SP-99577	3.0.0	Transferred from GSM 12.15 v7.4.0
S_07	3.0.0	001	SP-000017	3.1.0	IP v6 support to GTP'
S_07	3.0.0	002	SP-000017	3.1.0	GTP' header length fix
S_07	3.0.0	003	SP-000017	3.1.0	Charging Characteristics to CDRs
S_07	3.0.0	004	SP-000017	3.1.0	include MSISDN in S,G,M-CDR
Mar-2000	3.1.0			3.1.1	Cosmetic