

3GPP - TSG SA #5
11-13 October, 1999
Kyongju, Korea

Tdoc SP-99408

Title: 3G TS 23.171 V 1.0.0:
Location Services (LCS) in UMTS - Stage 2

Date: 1999-10-06

Source: S2

Purpose: For information

Agenda Point: 5.2.3

The attached document contains version 1.0.0 of the 3G TS 23.171: *Location Services (LCS) in UMTS - Stage 2*.

3G TS 23.171 1.0.0 (1999-10)

Technical Specification

3rd Generation Partnership Project; Technical Specification Group Services and System Aspects; Functional stage 2 description of location services in UMTS, (3G TS 23.171 version 1.0.0)



The present document has been developed within the 3rd Generation Partnership Project (3GPPTM) and may be further elaborated for the purposes of 3GPP. The present document has not been subject to any approval process by the 3GPP Organisational Partners and shall not be implemented. This Specification is provided for future development work within 3GPP only. The Organisational Partners accept no liability for any use of this Specification. Specifications and reports for implementation of the 3GPPTM system should be obtained via the 3GPP Organisational Partners' Publications Offices.

Reference

DTS/TSGS-0122121U

Keywords

<UMTS, LCS>

3GPP

Postal address

3GPP support office address

650 Route des Lucioles - Sophia Antipolis
Valbonne - FRANCE
Tel.: +33 4 92 94 42 00 Fax: +33 4 93 65 47 16

Internet

<http://www.3gpp.org>

Contents

Foreword.....	5
1 Scope	6
2 References.....	6
2.1 Normative references	6
2.2 Informative references	7
3 Definitions and abbreviations.....	7
3.1 Definitions.....	7
3.2 Abbreviations	8
4 Main concepts	8
4.1 Assumptions.....	9
4.2 Location Services Categories	9
4.3 Locating methods	10
4.3.1 Standard LCS Methods in release 99.....	10
4.4 Location information sources, network interaction.....	10
5 General LCS architecture.....	11
5.1 LCS access interfaces and reference points	11
5.2 LCS Functional diagram, high level functions	11
5.3 LCS Client functional group.....	13
5.3.1 External Location Client Function (LCF)	13
5.3.2 Internal Location Client Function U-LCF).....	13
5.3.3 Location Client Coordinate Transformation Function (LCCTF).....	13
5.4 LCS Server functional group in UMTS PLMN.....	13
5.4.1 Client handling component	13
5.4.1.1 Location Client Control Function (LCCF).....	13
5.4.1.2 Location Client Authorization Function (LCAF).....	14
5.4.1.2.1 Access Subfunction.....	14
5.4.1.2.2 Subscription Subfunction.....	14
5.4.2 System handling component.....	14
5.4.2.1 [Stand-alone LMU Mobility Management Function (LMMF)]	14
5.4.2.2 Location System Control Function in general (LSCF)	14
5.4.2.3 UTRAN Location System Control Function in RNC (U-LSCF)	15
5.4.2.4 Location System Billing Function (LSBF).....	15
5.4.2.5 Location System Operations Function (LSOF)	15
5.4.3 Subscriber handling Component.....	15
5.4.3.1 Location Subscriber Authorization Function (LSAF).....	15
5.4.3.2 Location Subscriber Privacy Function (LSPF)	15
5.4.4 Positioning component	15
6 UMTS LCS Architecture.....	15
6.1 Schematic functional description of LCS operations in UMTS	16
6.2 Allocation of LCS functions to UMTS network elements	18
6.3 Functional description of LCS per network element.....	20
6.3.1 UTRAN.....	20
6.3.2 LCS Clients and LCS applications.....	20
6.3.3 Gateway Mobile Location Center, GMLC.....	20
6.3.4 Serving RNC.....	21
6.3.5 LCS support in the Mobile Station.....	21
6.3.6 Node B	21
6.3.7 LMU	21
6.3.8 3G-MSC/VLR	21
6.3.9 3G-SGSN.....	21
6.3.10 Home Location Register, HLR.....	21

6.3.11	gsmSCF	21
7	Signaling Protocols and Interfaces.....	22
7.1	Generic signalling model for LCS in UMTS	22
7.2	Iu interface	23
7.2.1	Information Flows between UTRAN and the Core Network.....	23
7.2.2	Location Service Request.....	23
7.2.3	Location Service Response	24
7.2.4	Signaling RNC – MSC.....	24
7.2.5	Signaling RNC - SGSN	24
7.3	Iur Interface, Signaling between RNCs	24
7.4	Iub Interface, signaling between RNC, Node B and LMU	25
7.4.1	Signaling between RNC and LMU in Node B.....	25
7.5	Uu Interface.....	25
7.5.1	Signaling between RNC and Target MS	25
7.5.2	(Signaling between RNC and standalone LMU?).....	26
7.6	Signaling Protocols.....	26
8	General network location procedures.....	26
8.1	State description for GMLC	26
8.2	State description for 3G-MSC/VLR	26
8.3	State description for 3G-SGSN	26
8.4	State description for RNC	26
9	Information storage.....	26
10	Operational aspects	26
11	History	26
DEFINITIONS and terms	ANNEX 1	27

Foreword

This Technical Specification has been produced by the 3GPP.

The contents of the present document are subject to continuing work within the TSG and may change following formal TSG approval. Should the TSG modify the contents of this TS, it will be re-released by the TSG with an identifying change of release date and an increase in version number as follows:

Version x.y.z

where:

- x the first digit:
 - 1 presented to TSG for information;
 - 2 presented to TSG for approval;
 - 3 Indicates TSG approved document under change control.
- y the second digit is incremented for all changes of substance, i.e. technical enhancements, corrections, updates, etc.
- z the third digit is incremented when editorial only changes have been incorporated in the specification;

1 Scope

This document specifies the stage 2 of the LoCation Services (LCS) feature in UMTS, which provides the mechanisms to support mobile location services for operators, subscribers and third party service providers.

Location Services may be considered as a network provided enabling technology consisting of standardised service capabilities, which enable the provision of location applications. The application(s) may be service provider specific. The description of the numerous and varied possible location applications which are enabled by this technology are outside the scope of this specification. However, clarifying examples of how the functionality being described may be used to provide specific location services may be included.

This stage 2 service description covers the LCS system functional model for the whole system, the LCS system architecture, state descriptions, message flows, etc.

2 References

References may be made to:

- a) Specific versions of publications (identified by date of publication, edition number, version number, etc.), in which case, subsequent revisions to the referenced document do not apply; or
- b) All versions up to and including the identified version (identified by "up to and including" before the version identity); or
- c) All versions subsequent to and including the identified version (identified by "onwards" following the version identity); or
- d) Publications without mention of a specific version, in which case the latest version applies.

A non-specific reference to an ETS shall also be taken to refer to later versions published as an EN with the same number.

2.1 Normative references

- [1] 3G TR 25.923: "Report on Location Services (LCS)"[New title proposed: "Functional stage 2 specification of location services in UTRAN.]
- [2] GSM 01.04 (ETR 350): "Abbreviations and acronyms"
- [3] [reserved for UMTS abbreviations and acronyms]
- [4] 3G TS 22.071: "Location Services (LCS); Service description, Stage 1"
- [5] GSM 03.71: "Location Services (LCS); (Functional description) - Stage 2"
- [6] GSM 03.32: "Universal Geographical Area Description"
- [7] 3G TS 22.100: "UMTS phase 1 Release 99"
- [8] 3G TS 22.101: " Service principles"
- [9] 3G TS 22.105: " Services and Service Capabilities"
- [10] 3G TS 22.115: "Charging and Billing"
- [11] 3G TS 22.121: "The Virtual Home Environment"
- [12] 3G TS 23.110: "UMTS Access Stratum; Services and Functions"

- [13] PD 30.lcs: "Project Plan for location services in UMTS"

2.2 Informative references

- [14] Third generation (3G) mobile communication system; Technical study report on the location services and technologies, ARIB ST9 December 1998.
- [15] The North American Interest Group of the GSM MoU ASSOCIATION: Location Based Services, Service Requirements Document of the Services Working Group

3 Definitions and abbreviations

3.1 Definitions

The following terms are defined in Annex 1:

CAMEL
Current Location
Deferred location request
Global Positioning System (GPS)
Immediate location request
Initial Location
Last Known Location
LCS (LoCation Services)
LCS Client
LCS Client Access barring list
LCS Client Subscription Profile
LCS Feature
LCS Server
Local Service
Local Information
Location (Based) Application
Location Based Service (LBS)
Location Dependent Service
Location Estimate
Location Independent Service
Mobile Station (MS)
PLMN Access barring list
Positioning (/location detecting)
Positioning method (/locating method)
Positioning technology (/locating technology)
Predefined area
Privacy Class
Privacy Exception List
Prohibited area
Subscription Profile
Target MS
...

Further UMTS related definitions are given in 3G TS 22.101.

3.2 Abbreviations

For the purposes of this TS the following abbreviations apply:

AI	Application Interface (prefix to interface class method)
CAMEL	Customised Application For Mobile Network Enhanced Logic
CSE	Camel Service Environment
GPS	Global Positioning System
HE	Home Environment
HLR	Home Location Register
LBS	Location Based Services
LCS	LoCation Services
LIR	Location Immediate Request,
LDR	Location Deferred Request
MAP	Mobile Application Part
ME	Mobile Equipment
MExE	Mobile Station (Application) Execution Environment
MS	Mobile Station
MSC	Mobile Switching Centre
OSA	Open Service Architecture
PLMN	Public Land Mobile Network
PSE	Personal Service Environment
SAT	SIM Application Tool-Kit
SIM	Subscriber Identity Module Short Message Service
SI	Service Interface (prefix to interface class method)
UE	User Equipment
USIM	User Service Identity Module
VASP	Value Added Service Provider
VHE	Virtual Home Environment
...	

Further GSM related abbreviations are given in GSM 01.04. Further UMTS related abbreviations are given in UMTS TS 22.101.

4 Main concepts

A general description of location services and service requirements are given in the specification 3G TS 22.071 [4].

Both GSM BSS and UTRAN shall facilitate determination of the locations of mobile stations.

By making use of the UTRAN radio signals the capability to determine the (geographic) location of the user equipment (UE) mobile station shall be provided. The location information may be requested by and reported to a client (application) associated with the UE, or by a client within or attached to the Core Network. The location information may also be utilised internally by UMTS, for example, for location assisted handover or to support other features such as home location billing. The position information shall be reported in standard formats, such as those for cell based or geographical co-ordinates, together with the time-of-day and the estimated errors (uncertainty) of the location of the UE.

It shall be possible for the majority of the UE (active or idle) within a network to use the feature without compromising the radio transmission or signalling capabilities of the UMTS.

The uncertainty of the location measurement shall be network design (implementation) dependent at the choice of the network operator, this is further described in TR 25.923[1].

There are many different possible uses for the location information. The positioning feature may be used internally by the UMTS network (or attached networks), by value-added network services, by the UE itself or through the network, and by “third party” services. The positioning feature may also be used by an emergency service (which may be

mandated or “value-added”), but the position service is not exclusively for emergencies.

The UTRAN is a new radio system design without a pre-existing deployment of UE operating according to the air interface. This freedom from legacy equipment enables the positioning service feature design to make use of appropriate techniques to provide the most accurate results. The technique must also be a cost-effective total solution, must allow evolution to meet evolving service requirements and be able to take advantage of advances in technology over the lifetime of UTRAN deployments.

4.1 Assumptions

[This chapter shall be common for the System Stage 2 and UTRAN Stage 2 specifications.]

As a basis for the development work on LCS in UMTS the following assumptions apply:

1. In case an MS supports LCS, it shall support at least one of the selected locating method(s) specified in UTRAN Stage 2.
2. The provision of the location service in UTRAN is optional through support of the specified method(s) in Node-B and the associated RNC.
3. The provision of location services is optional in 3G-MSC and 3G-SGSN.
4. LCS is applicable to any target UE whether or not the UE supports LCS, but with restrictions on choice of positioning method or notification of a location request to the UE user when LCS or individual positioning methods, respectively, are not supported by the UE.
5. RNC contains SMLC functionality and LCS information is transported between RNCs via the Iur interface.
6. LCS shall be applicable for both circuit switched and packet switched services.
7. The location information may be used for internal system operations to improve system performance
8. The different types of LMU are FFS, e.g. the need for standalone LMU and/or LMU integrated in Node B.
9. The positioning process shall include the option to accommodate several techniques of measurement and processing to ensure evolution to follow changing service requirements and to take advantage of advancing technology.
10. Iur shall be used for LCS signalling whenever it is available, even in the case when the RNCs are connected to different 3G-MSCs or 3G-SGSNs

4.2 Location Services Categories

Generally there are four categories of usage of the location service. These are the Commercial LCS, the Internal LCS, the Emergency LCS and the Lawful Intercept LCS. The definition of these services and their categories is outside the scope of this document.

- The **Commercial LCS** (or **Value Added Services**) will typically be associated with an application that provides a value added service through knowledge of the UE location to the subscriber of the service. This may be, for example, a directory of restaurants in the local area of the UE together with directions for reaching them from the current UE location.
- The **Internal LCS** will typically be developed to make use of the location information of the UE for UTRAN internal operations. This may include, for example, location assisted handover and traffic and coverage measurement. This may also include support certain O&M related tasks, supplementary services, IN related services and GSM bearer services and teleservices.
- The **Emergency LCS** will typically be part of a service provided to assist subscribers who place emergency calls. In this service, the location of the UE caller is provided to the emergency service provider to assist them in their response. This service may be mandatory in some jurisdictions. In the United States, for example, this service is mandated for all mobile voice subscribers.

- The **Lawful Intercept LCS** will use the location information to support various legally required or sanctioned services.

4.3 Locating methods

The LCS feature utilizes one or more locating methods in order to determine the location of user equipment (UE) or Mobile Stations. Locating the position of a UE involves two main steps:

- signal measurements and
- position estimate computation based on the measurements.

The signal measurements may be made by the UE, the Node B or a dedicated location measuring unit (LMU). The basic signals measured are typically the UTRA radio transmissions, but some optional methods may make use of other transmissions such as general radio navigation signals. The location estimate computation may be made in the UE or by a calculation function located in the UTRAN.

A number of positioning mechanisms are possible for LCS. These include:

- Cell identity (The representation of "Cell ID" in Iu signaling is FFS, since radio aspects should be hidden from the core network.)
- Observed Time Difference of Arrival (OTDOA), with optional Idle Period DownLink (IPDL)
- Round Trip Time (RTT),
- General navigation system assisted (e.g. GPS)
- Reference Node Based Positioning
- Angle of arrival (AOA),
- Observed Time of Arrival (OTOA) and

These locating methods are further described in the report TR25.923. [1], The positioning process shall include the option to accommodate several techniques of measurement and processing to ensure evolution to follow changing service requirements and to take advantage of advancing technology.

4.3.1 Standard LCS Methods in release 99

The specification 25.923 UTRAN Stage 2 [1] specifies the locating methods to be supported in Release 99:

- *Cell coverage based positioning method;*
- *OTDOA method with network configurable idle periods (the idle period configurability is to be specified in the specification); and*
- *network assisted GPS methods; (note: GPS based solutions are being standardised in T1P1; it is intended that the UTRAN navigational assisted solution will be synergistic with the work in T1P1)".*

4.4 Location information sources, network interaction

The location service design should not be limited to a single technique or source of information. As operating conditions vary both within and between networks, the LCS design should be able to make use of as many measurements and techniques as are available and are appropriate for the needs of (and the cost of) the service being provided.

The location process shall include the option to include all of the available UTRAN signals, including those from other networks with coverage available to the UE. While it should not be necessary for the UE to access these other networks, the UE and the location process should be able to make use of the signals from these sources in addition to those of the serving network. It should be noted that the UE does not need to access a foreign network in order to make

OTDOA measurements of the downlink signals.

It is critical to positioning accuracy that as many measurements are used as possible. This is particularly important in regions where the serving operator may provide coverage with only a single base station. Typically there will be additional coverage of these regions by other operators, but perhaps only from one base station from each operator. By making measurements of the signals from several operators the UE will typically be able to obtain information to make a better location estimate than would be possible with just the signals from a single operator (assuming that the base stations are not colocated). The use of signals and other information from several operators would, of course, be subject to suitable operator agreement.

In some cases the UE may be able to operate in other modes (e.g. GSM) for which a location service feature is also provided. The signals of the other mode and location information may be helpful to the UMTS LCS. For example, measurements of the GSM signals may be used by the UTRAN LCS calculation function to supplement the UTRAN radio measurements. The use of this information would, of course, be subject to suitable operator agreements. The techniques for this inter-mode operation and any signalling between networks are FFS.

The LCS information sources and the signalling required for their interaction, are FFS.

5 General LCS architecture

5.1 LCS access interfaces and reference points

There is one reference point between the LCS server and LCS client called Le, see Figure 5.1. Le is described in TS 22.071 [4], however the protocol specifics are for further study. There may be more than a single LCS network interface to several different LCS clients or other networks. These networks may both differ in ownership as well as in communications protocol. The network operator should define and negotiate interconnect with each external LCS client or other network.

An interface differs from a reference point in that an interface is defined where specific LCS information is exchanged and needs to be fully recognized.

There is an interface called Lg that connects two independent LCS networks (different PLMNs) for message exchange.

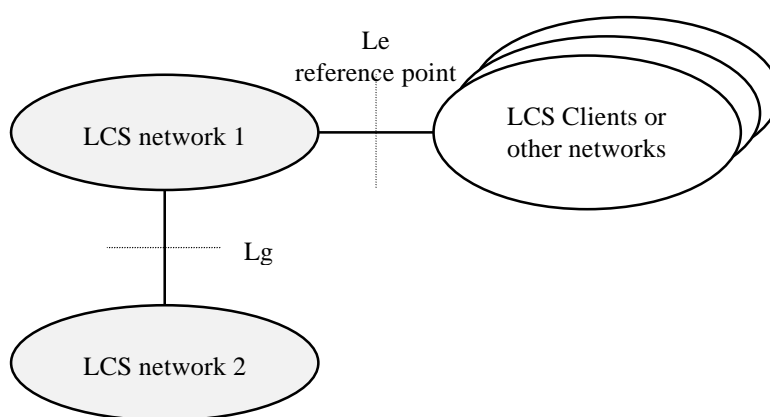

Figure 5.1, LCS Access Interfaces and Reference Points

5.2 LCS Functional diagram, high level functions

TS 22.071 [4] describes LCS services from the LCS client point of view. In this specification, a more detailed

description of LCS is given. The LCS functional diagram shown in Figure 5.2 depicts the interaction of the LCS client and the LCS server within the PLMN. The PLMN uses the various LCS components within the LCS server to provide the target MS Location Information to the LCS client.

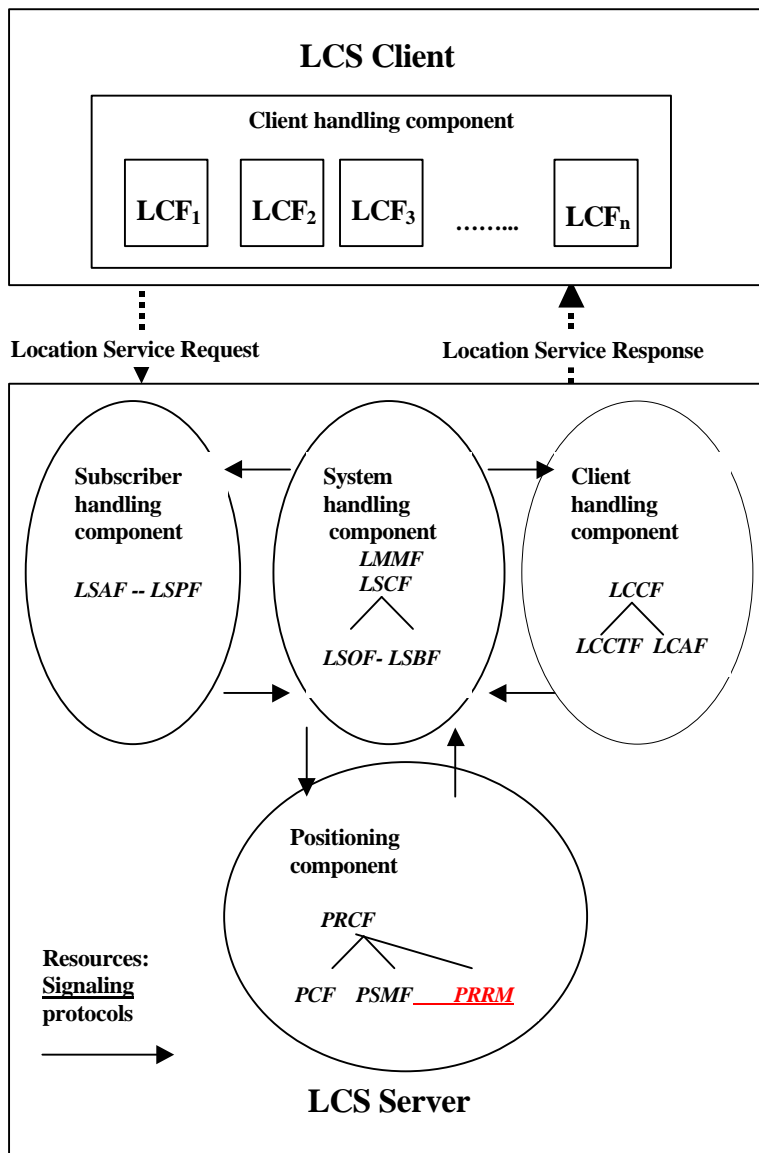

Figure 5.2, PLMN LCS capability server Functional Diagram

The following list gives the logical functional entities for the LCS. Two main functional groupings are defined which encompass a number of smaller functions.

The LCS Functional entities are grouped as follows :

- The LCS Client functional group
- The LCS Server functional group consists of functions in the UMTS PLMN supporting LCS:
 - Client handling component
 - System handling componen
 - Subscriber handling Component
 - Positioning component

The functions of the LCS Client and the LCS Server in UMTS PLMN are described in more detail in this chapter.

The allocation of LCS functions to UMTS network elements is specified in chapter 6.

5.3 LCS Client functional group

An LCS client contains an LCS component with one or more client(s) which by using location information can provide location based services.

An LCS client is a logical functional entity that requests from the LCS server in the PLMN location information for one or more than one target MS within a specified set of parameters such as Quality of Service (QoS). The LCS Client may reside in an entity (including the MS) within the PLMN or in an entity external to the PLMN.

The specification of the LCS Client's internal logic and its relation to the external use is outside the scope of this document.

5.3.1 External Location Client Function (LCF)

The Location Client Function (LCF) provides a logical interface between the LCS client and the LCS server.

This function is responsible for requesting location information for one or more MEs/MSs, with a specified "QoS" [this is only possible if the location request originates in the core network] and receiving a response, which contains either location information or a failure indicator.

5.3.2 Internal Location Client Function U-LCF)

The Location Client Function (LCF) provides a logical interface between the internal UTRAN LCS applications and the UTRAN LCS system handling entities (*e.g. the Location System Control Function (U-LSCF) in the UTRAN.*)

The UTRAN may make use of location information for internal operations such as location assisted handover. In such a case, a U-LCF representing the internal UTRAN LCS application may communicate with the U-LSCF to request and receive the location information.

[This description should be elaborated. This function is not included in GSM.
Does this need an interface U-LCF-RNC to be specified?]

5.3.3 Location Client Coordinate Transformation Function (LCCTF)

The Location Client Coordinate Transformation Function (LCCTF) provides conversion of a location estimate expressed according to a universal latitude and longitude system into an estimate expressed according to a local geographic system understood by the LCF and known as location information. The local system required for a particular LCF will be either known from subscription information or explicitly indicated by the LCF.

5.4 LCS Server functional group in UMTS PLMN

The LCS server functional group consists of the UMTS PLMN functions, that are needed for UMTS to support Location Services.

5.4.1 Client handling component

5.4.1.1 Location Client Control Function (LCCF)

The Location Client Control Function (LCCF) manages the external interface towards LCF. The LCCF identifies the LCS client by requesting client verification and authorization (i.e. verifies that the LCS client is allowed to position the subscriber) through interaction with the Location Client Authorization Function (LCAF) . The LCCF handles mobility management for location services (LCS) e.g., forwarding of positioning requests to VMSC. The LCCF determines if the final positioning estimate satisfies the QoS for the purpose of retry/reject. The LCCF provides flow

control of positioning requests between simultaneous positioning requests. It may order the Location Client Coordinate Transformation Function (LCCTF) to perform a transformation to local coordinates. It also generates charging and billing related data for LCS via the Location System Billing Function (LSBF).

5.4.1.2 Location Client Authorization Function (LCAF)

The Location Client Authorization Function (LCAF) is responsible for providing access and subscription authorization to a client. Specifically, it provides authorization to a LCS client requesting access to the network and authorizes the subscription of a client. LCAF provides authorization to a LCS client requesting Location Information of a specific MS.

5.4.1.2.1 Access Subfunction

An *Access Subfunction* enables LCS clients to access LCS services. This subfunction provides verification and authorization of the requesting client.

When a LCS is requested, the Access Subfunction uses the information stored in the LCS client *subscription profile* to verify that:

- the LCS client is registered; and
- the LCS client is authorized to use the specified LCS request type;
- the LCS client is allowed to request location information for the subscriber(s) specified in the LCS request;

5.4.1.2.2 Subscription Subfunction

The LCS client Subscription profile shall contain a minimum set of parameters assigned on per LCS client basis for an agreed contractual period. The LCS client profile shall contain the following set of access parameters:

- LCS client identity;
- Allowed LCS request types (i.e. LIR, LDR or both); see note
- Maximum number of subscribers allowed in a single LCS request;
- Priority;
- Position override indicator;
- State(s) ;
- Event(s) (applicable to LDR requests only) ;
- Local coordinate system;
- LCS client access barring list (optional);
- PLMN access barring list applicability ;

Note: LIR =Location Immediate Request ; and LDR= Location Deferred Request

For certain authorized LCS client internal to the PLMN, a subscription profile is unnecessary. These clients are empowered to access any defined service that is not barred for an MS subscriber. This permits positioning of emergency calls without the need for pre-subscription.

5.4.2 System handling component

5.4.2.1 [Stand-alone LMU Mobility Management Function (LMMF)]

The stand-alone LMU is for further study in UMTS.

5.4.2.2 Location System Control Function in general (LSCF)

The Location System Control Function (LSCF) is responsible for coordinating location requests. This function manages call-related and non-call-related positioning requests of LCS and allocates network resources for handling them. The LSCF retrieves MS classmark for the purpose of determining a positioning method. The LSCF performs call setup if required as part of a LCS e.g., putting the ME in a dedicated mode and obtains Cell-ID. It also caters for

coordinating resources and activities with regard to requests related to providing assistance data needed for positioning. This function interfaces with the LCCF, LSPF, LSBF and PRCF. Using these interfaces, it conveys positioning requests to the PRCF, relays positioning data to the LCCF and passes charging related data to the LSBF.

5.4.2.3 UTRAN Location System Control Function in RNC (U-LSCF)

The UTRAN Location System Control Function in RNC is responsible for co-ordinating location requests within the RNC handling entity. This function manages call-related and non-call-related location requests and allocates network resources for handling them. This function “insulates” the Location clients in the Core Network from the detailed operation of the location method in order that the UTRAN may be used by several types of core network and with several location methods. The U-LSCF is further described in UTRAN Stage 2. Location System Billing Function (LSBF)

The Location System Billing Function (LSBF) is responsible for charging and billing activity within the network related to location services (LCS). This includes charging and billing of both clients and subscribers. Specifically, it collects charging related data and data for accounting between PLMNs.

5.4.2.4 Location System Operations Function (LSOF)

The Location System Operations Function (LSOF) is responsible for provisioning of data, positioning capabilities, data related to clients and subscription (LCS client data and MS data), validation, fault management and performance management of UMTS LCS.

An LSOF may be associated with each entity.

5.4.3 [This is being studied in GSM. FFS in UMTS. Internal LCF may be part of O&M functions.]Subscriber handling Component

5.4.3.1 Location Subscriber Authorization Function (LSAF)

The Location Subscriber Authorization Function (LSAF) is responsible for authorizing the provision of a location service (LCS) for a particular mobile station (UE with SIM/USIM). Specifically, this function validates that a LCS can be applied to a given subscriber. In case LCF is in the MS then LSAF verifies that the MS subscriber has subscribed to the requested LCS service.

5.4.3.2 Location Subscriber Privacy Function (LSPF)

The Location Subscriber Privacy function is responsible performs all privacy related authorizations. For an target MS it shall authorize the positioning request versus the privacy options of the target MS, if any.

5.4.4 Positioning component

The positioning components UTRAN Positioning Radio Coordination Function (U-PRCF), UTRAN Positioning Calculation Function (U-PCF), UTRAN Positioning Signal Measurement Function (U-PSMF) and UTRAN Positioning Radio Resource Management (U-PRRM) are described in UTRAN Stage 2.

6 UMTS LCS Architecture

Figure 6.1 shows the general arrangement of the Location Service feature in UMTS. This illustrates, generally, the relation of LCS Clients and servers in the core network with the UTRAN. The LCS entities within the UTRAN communicate with the Core Network (CN) across the Iu interface. Communication among the UTRAN LCS entities makes use of the messaging and signalling capabilities of the UTRAN.

As part of their service or operation, the LCS Clients may request the location information of user equipment UE (UE without a valid SIM/USIM) or mobile stations. There may be more than one LCS client. These may be associated

with the UMTS network or the UTRAN, operated as part of a UE application or accessed by the UE through its access to an application (e.g. through the Internet).

The clients make their requests to an LCS Server. There may be more than one LCS Server. The client must be authenticated and the resources of the network must be co-ordinated, including the Node-Bs (base stations), the UE and the calculation functions, to estimate the location of the UE and result returned to the client. As part of this process, information from other systems (outside UTRAN) can be used. As part of the location information returned to the client, an estimate of the accuracy of the estimate and the time-of-day the measurement was made shall be provided.

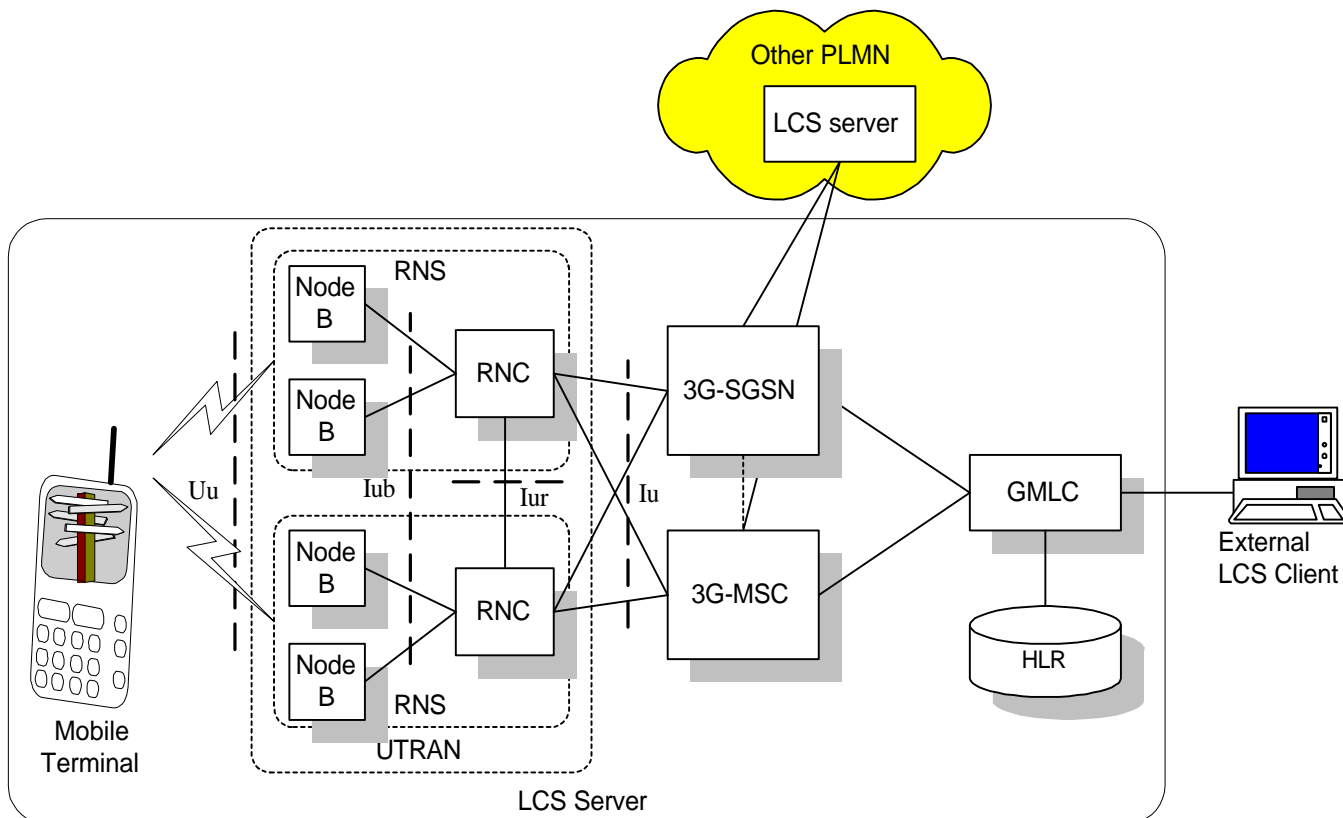

Figure 6.1, General arrangement of LCS in UMTS

6.1 Schematic functional description of LCS operations in UMTS

The allocation of LCS functional blocks to the Client, LCS server, Core Network, UTRAN and mobile station is based on the schematic functional description below. The detailed functions and interactions are specified later in this document and in TR25.923 and corresponding Stage 3 specifications.

The operation begins with a LCS Client requesting location information for a UE from the LCS server. The LCS server will pass the request to the LCS functional entities in the UMTS core network. The LCS functional entities in the core network shall then:

- verify that the LCS Client is authorized to request the location of the UE or subscriber
- verify that LCS is supported by the UE
- establish whether it is allowed to locate the UE or subscriber, for privacy or other reasons
- establish which Serving RNC should receive the Location request if necessary by establishing a connection with the UE.

- request the UTRAN (via the serving RNC) to provide location information for an identified UE, with indicated QoS
- receive information about the location of the UE from UTRAN and forward it to the Client
- send appropriate accounting information to an accounting function.

The UTRAN LCS functional entities shall:

- request measurements, typically from the UE and one or more Node-B (or LMU) radio apparatus,
- send the measurement results to the appropriate calculating function within UTRAN,
- receive the result from the calculating function within UTRAN,
- perform any needed co-ordinate transformations,
- send the results to the LCS entities in the core network.

In the event that the client is internal to UTRAN the request may be made directly to the UTRAN LCS entities as the internal clients are considered to be “pre-authorised”.

As part of its operation, the calculating function may require additional information. This may be obtained by the function directly by communication with a database, or it may be through a request to LCS entities that will mediate the request and return of information from the appropriate database (or databases if more than one is needed to fulfill the requests). The LCS application may make use of the position information itself, or further process and then forward the information to other authorised applications within or external to the UTRAN.

There may possibly also be available independent information that is able to supply the location information directly, or may be able to supply auxiliary information to the calculation function. The LCS co-ordination function, as part of its activity to supervise the positioning process, may query the UE or other elements of the network to determine their capabilities and use this information to select the mode of operation.

This general operation is outlined in the following (generic) sequence diagram in Figure 6.2. This figure is not intended to show the complete LCS operation, but to simply to outline the basis for operation.

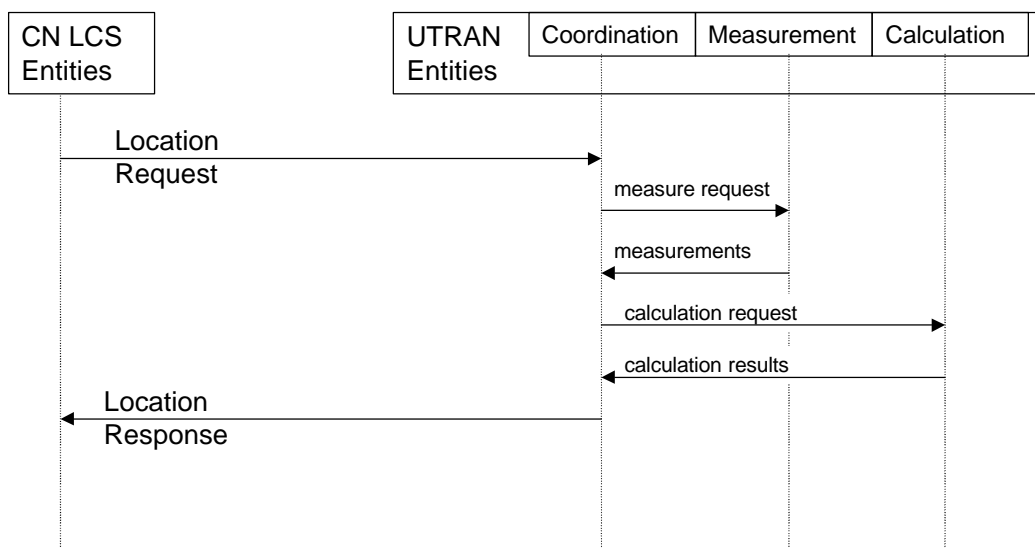

Figure 6.2, General sequence for LCS operation

6.2 Allocation of LCS functions to UMTS network elements

Table 6.1 shows a summary of the Functional Groups and Functional Blocks for Location services in UMTS. Table 6.2 and Figure 6.3 show the generic configuration for LCS in UMTS and the distribution of LCS functional blocks to UMTS network elements. Different positioning methods, including network-based, mobile-based, mobile-assisted and network-assisted positioning methods shall be supported. With this configuration both the network and the mobiles are able to measure the timing of signals and compute the mobile's location estimate. Depending on the applied positioning method it is possible to utilize the corresponding configuration containing all needed entities. For instance, if network-based positioning is applied, the entities that are involved in measuring the mobile's signal and calculating its location estimate are allocated to the network elements of the access stratum. On the other hand, in case mobile-based or network-assisted methods are used these entities should be allocated to the mobile station.

LCS is logically implemented on the UMTS structure through the addition of one network node, the Mobile Location Center (MLC). It is necessary to name a number of new interfaces. The LCS generic architecture can be combined to produce LCS architecture variants.

Func. Group	Functional component	Full name of Functional Block	Abbrev
Loc. Client	Location Client component	(External) Location Client Function	LCF
		Internal Location Client Function	U-LCF -internal
		Location Client Coordinate Transformation Function	LCCTF
LCS Server in PLMN	Client handling component	Location Client Control Function	LCCF
		Location Client Authorization Function	LCAF
	System handling component	Stand-alone LMU Mobility Management Function	LMMF
		Location System Control Function	LSCF
		Location System Control Function in RNC	U-LSCF
		Location System Billing Function	LSBF
		Location System Operations Function	LSOF
	Subscr. handling component	Location Subscriber Authorization Function	LSAF
		Location Subscriber Privacy function	LSPF
	Positioning component	Positioning Radio Control Function	PRCF
		Positioning Calculation Function	PCF
		Positioning Signal Measurement Function	PSMF
		Positioning Radio Resource Management	PRRM

Table 6.1, Summary of Functional Groups and Functional Blocks for Location services in UMTS

Figure 6.3 illustrates the allocation of functional entities in the reference configuration of LCS in UMTS. It is assumed that the CS and PS have either their own independent mobility management or use the joint mobility management through the optional Gs interface.

The mobile positioning calculation is to be done in the Serving RNC in UTRAN. Thus, it is pointed out that there is no need for a Serving MLC in the model.

It is also seen that LCS in UMTS shall take benefit of the standardized Iur interface between RNCs, when base station information and measurement results are collected.

The functional model presented in the figure includes functional entities for both CS and PS related LCS. In addition, it consists of all the entities needed for different positioning methods, i.e. network based, mobile based, mobile assisted, and network assisted positioning, exploiting either uplink or downlink measurements. It is noted that the mobile station may use e.g. the GPS positioning mechanism, but still demand e.g. auxiliary measurements from the

serving network

	MS	RAN	GMLC	3G-SGSN	3G-MSC	Client
Location client functions						
LCF	X			X	X	X
U-LCF Internal	ffs	X				
LCCTF			X			
Client handling functions						
LCCF			X			
LCAF			X			
System handling functions						
LMMF				?	?	
LSCF				X	X	
U-LSCF		X				
LSBF			X	X	X	
LSOF	X	X	X	X	X	
Subscriber handling functions						
LSAF				X	X	
LSPF				X	X	
Positioning functions						
PRCF		X				
PCF	X	X				
PSMF	X	X				
PRRM		X				
	MS	RAN	GMLC	3G-SGSN	3G-MSC	Client

Table 6.2, Allocation of LCS functional entities to network elements

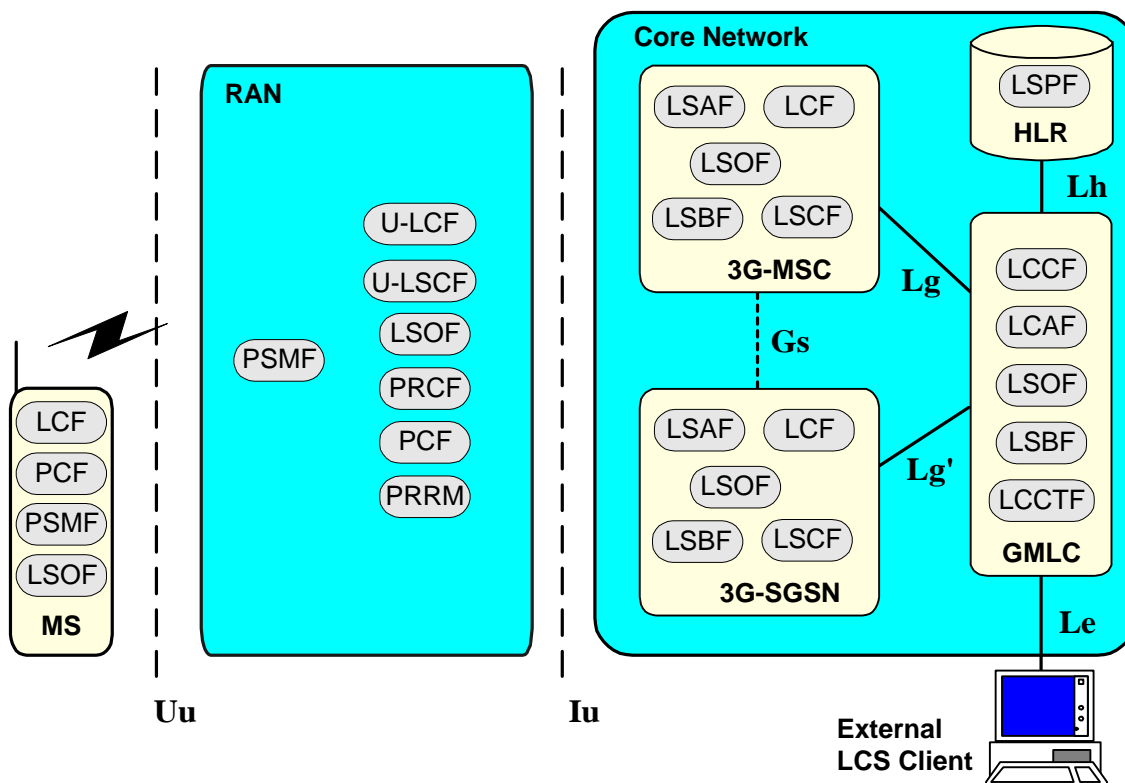

Figure 6.3, Generic LCS Logical Architecture

6.3 Functional description of LCS per network element

6.3.1 UTRAN

The UTRAN is involved in the handling of various positioning procedures. Specific UTRAN functionality is specified in each of the positioning procedures sections in TR25.923.

6.3.2 LCS Clients and LCS applications

There are two classes of LCS Application – Internal applications and External applications. Internal applications represent entities internal to the UMTS that make use of location information for the (improved) operation of the network. External applications represent entities (such as Commercial or Emergency services) that make use of location information for operations external to the mobile communications network. The LCS Applications interface to the LCS entities through their Location Client functions (LCF).

The LCS Client and LCS applications are outside the scope of this standard.

6.3.3 Gateway Mobile Location Center, GMLC

The Gateway Mobile Location Center (GMLC) contains functionality required to support LCS. In one PLMN, there may be more than one GMLC.

The GMLC is the first node an external LCS client accesses in a GSM PLMN (i.e. the Le reference point is supported by the GMLC). The GMLC may request routing information from the HLR via the Lh interface or from 3G-SGSN via the Lg' interface. After performing registration authorization, it sends positioning requests to and receives final location estimates from the 3G-VMSC via the Lg interface or from the 3G-SGSN via the Lg' interface.

6.3.4 Serving RNC

The Serving RNC (SRNC) is a network element of UTRAN and contains functionality required to support LCS in PLMN. The LCS functionality of SRNC is given in [1].

6.3.5 LCS support in the Mobile Station

The MS may be involved in the various positioning procedures. Specific MS involvement is specified in each of the positioning procedures specified in TR 25.923.

The MS interacts with the measurement coordination functions to transmit the needed signals for uplink based LCS measurements and to make measurements of downlink signals. The measurements to be made will be determined by the chosen location method.

The MS may also contain LCS applications, or access an LCS application through communication with a network accessed by the MS or an application residing in the MS. This application may include the needed measurement and calculation functions to determine the MS's location with or without assistance of the UMTS LCS entities.

The MS may also, for example, contain an independent location function (e.g. Global Satellite Positioning Service GPS) and thus be able to report its location, independent of the UTRAN transmissions. The MS with an independent location function may also make use of information broadcast by the UTRAN that assists the function.

6.3.6 Node B

6.3.7 LMU

The Location Measurement Unit LMU entity makes measurements (e.g. of radio signals) and communicates these measurements to the PRCF in RNC. The LMU contains a PSMF and may also perform calculations associated with the measurements. The LMU is described in [1].

6.3.8 3G-MSC/VLR

The 3G-MSC/VLR contains functionality responsible for MS subscription authorization and managing call-related and non-call related positioning requests of LCS. The 3G-MSC is accessible to the GMLC via the Lg interface.

6.3.9 3G-SGSN

The 3G service GPRS support node 3G-SGSN contains functionality responsible for MS subscription authorization and managing call-related and non-call related positioning requests of LCS. The 3G-SGSN is accessible to the GMLC via the Lg' interface.

6.3.10 Home Location Register, HLR

The HLR contains LCS subscription data and routing information. The HLR is accessible from the GMLC via the Lh interface. For roaming MSs, HLR may be in a different PLMN than the current SRNC.

6.3.11 gsmSCF

[The Lc interface supports CAMEL access to LCS and is applicable only in CAMEL phase 3. The procedures and signaling associated with it are defined in GSM 03.78 and GSM 09.02, respectively.]?

7 Signaling Protocols and Interfaces

7.1 Generic signalling model for LCS in UMTS

The following diagram illustrates the signalling operations for the OTDOA-LCS when the request for location information is initiated by an LCS application signalled via the Core Network. *As some of these operations are internal to the RNC, this diagram is to illustrate information flow and implementations may use alternate arrangements.*

This illustration only includes the signalling related to LCS operations and does not indicate other signalling that may be required, for example, to establish a signalling connection between the UE and the SRNC. Also not illustrated is the signalling used to initiate the location service request (from the Location Client Function) from the Core Network or a MS based application.

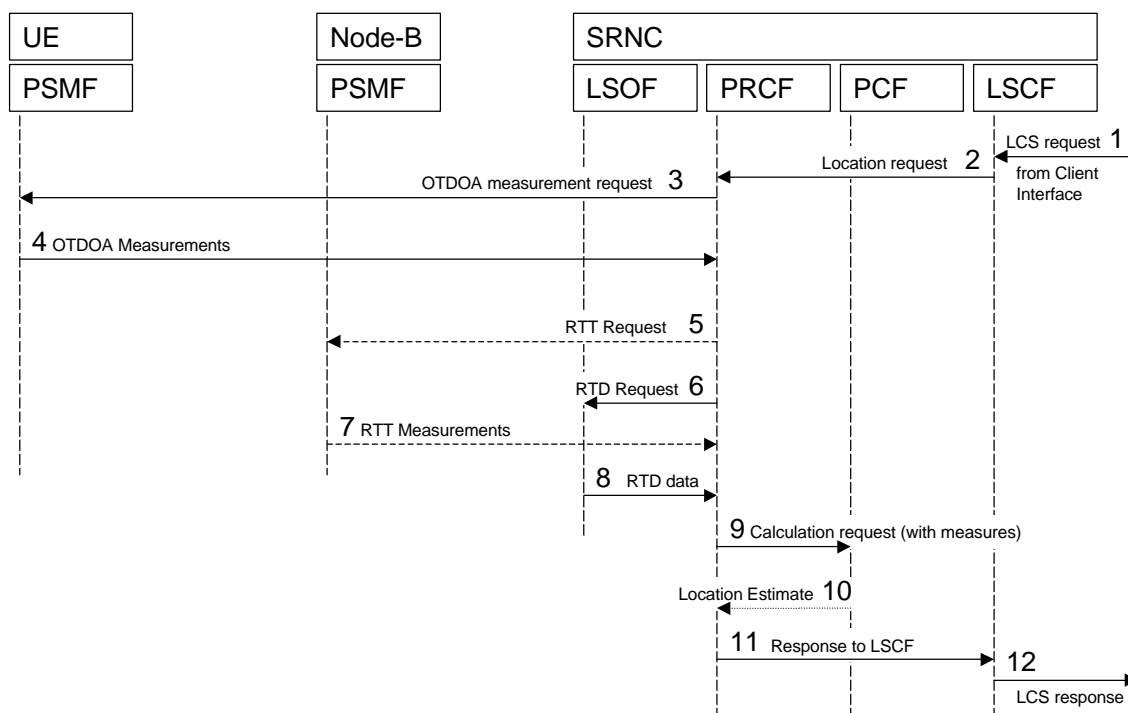

Figure 7.1. OTDOA Signalling Operations

[Comment: Figure to be updated to show UMTS network signalling operations and not element internal signaling.]

1. The OTDOA operation begins with an authenticated request for location information about a UE from an application in the core network being received at the LSCF. The LSCF acts as interface between the Core Network and the LCS entities in the UTRAN.
2. The LSCF considers the request and the capabilities of the UE and the network and forwards the request to the appropriate PRCF in the Serving RNC.
3. The PRCF requests from the UE the measurement of the OTDOA for the signals in the active and neighbourhood sets. These measurements may be made while the UE is in the idle state or while it is connected.
4. The UE returns the OTDOA measures to the PRCF. The PRCF receives the OTDOA information and coordinates obtaining other information to support the calculation request (not illustrated).
5. If there are insufficient OTDOA measures, or it is otherwise considered advantageous to do so, the PRCF requests the RTT measure for the UE from the PSMF in the serving Node-B.

6. The PRCF requests the RTD measures for the associated transmitters from the LSOF (database). These may be stored locally if they are constant over time, otherwise they must be updated to represent the RTD timing at the time-of-day the OTDOA measurements were made.
7. The PSMF in the Node-B returns the RTT measures to the PRCF if they were requested.
8. The LSOF returns the RTD information to the PRCF.
9. The PRCF passes the OTDOA, RTD and, if necessary, RTT information to the PCF and requests a location calculation. The calculation may include a coordinate transformation to the geographic system requested by the application.
10. The PCF returns the location estimate to the PRCF. This estimate includes the location, the estimated accuracy of the results and the time of day of the estimate.
11. The PRCF passes the location estimate to the LSCF.
12. The LSCF passes the location estimate to the Core Network.

7.2 Iu interface

The Iu interface is used to communicate between the LCS functional entities in the Core Network and the LCS entities in the UTRAN. Further specification of the messages and operations for LCS across the Iu interface may be found in reference [4].

This interface passes the location requests and responses from authenticated external and internal LCS applications between the LCS entities in the Core Network and the UTRAN LCS entities. The location request will include parameters to indicate the preferred location method and the quality of service (QoS). The QoS parameters will include the required speed of response, the preferred coordinate system and the required accuracy. The location results, error (failure) responses, and accounting/OAM information will be returned from the LCS entities in the UTRAN to the LCS entities in the core network.

The LCS entities in the UTRAN may also request from the core LCS entities information concerning the client subscriptions and UE privacy conditions that may be needed to support internal LCS application requests.

The Iu interface may also pass messages relating to records of operational usage of the LCS within UTRAN or reporting of the data associated with the Location System Operations Functions (LSOF) in the UTRAN. These may be used by the core network for accounting, billing or administration functions.

LCS signaling over the Iu interface is specified in the RANAP specification .

7.2.1 Information Flows between UTRAN and the Core Network

The information flows pass over the Iu interface between the UTRAN and the CN..

7.2.2 Location Service Request

Via the Location Service Request, the LCS client communicates with the LCS server to request for the location information of one or more than one MS within a specified quality of service. There exist two types of location service requests:

- Location Immediate Request (LIR); and
- Location Deferred Request (LDR).

The following attributes are identified for Location Service Request information flow: [This list is subject to further review.]

- Target MS ;
- Indication of what positioning methods are supported by the Target MS, generated based on MS Classmark [This and other parameters to indicate MS support of LCS is ffs.]
- LCS identity;
- State (idle, dedicated)
- Event (applicable to LDR requests only);
- Requested Quality of Service information;
- Estimated achieved QoS;
- Local coordinate reference system;
- Location of MS as an ellipsoid with axes and direction of all axis
- Location indication of MS in geographical coordinates
- Geographical area, [should be checked with the meaning of "Geographical area" in 03.71.]
- indication when MS enters or leaves the Geographical area.

7.2.3 Location Service Response

The Location Service Response is sent to the LCS client as the result of the Location Service Request by the LCS Server:

- Immediate Response; and
- Deferred Response;

These deferred responses can be either single or periodic.

7.2.4 Signaling RNC – MSC

7.2.5 Signaling RNC - SGSN

7.3 Iur Interface, Signaling between RNCs

The Iur interface is used to communicate between the LCS functional entities associated with the serving RNC and other RNC in the UTRAN. The Iur interface is also used to communicate between the serving RNC and the Internal LCS Applications in the UTRAN. The LCS entities associated with the serving RNC are responsible for coordinating and responding to location requests received from the LCS entities in the core network or Internal Clients

[Not agreed or understood: *When communicating between the serving RNC and the UTRAN Internal LCS Applications (ILA), the messages and protocols are the same as those used over the Iur interface.*]

The Iur interface is also used to communicate between the LCS Entities in the serving RNC and those in other RNC. The location method, for example, may require measurements by several LMU or Node-B, some of which may be associated with other RNC. Commands and responses from these LCS Entities are communicated over the Iur interface. In some cases, the LCS Entities in the serving RNC may make use of entities associated with other RNC. For example, a calculating function (PCF) may be used in another RNC if the serving RNC is too busy or does not contain the function or database information required by the chosen location method.

The Iur interface may also pass messages relating to changes or reporting of the data associated with the Location System Operations Function (LSOF) in the RNC.

Iur shall be used for LCS signalling whenever it is available, even in the case when the RNCs are connected to different 3G-MSCs or 3G-SGSNs.

Within UTRAN, Iur supports inter-RNC soft handover. Inter-RNC handover should also include LCS, meaning that whenever an inter-RNC soft handover occurs, Iur should be able to support the functionality of the positioning entities in RNCs, including PCF, PRRM, PSMF, and LSOF.

In addition, in case of SRNC relocation Iur should support the relocation mechanism in order for DRNC to be able to handle the responsibility of SRNC in LCS process. That is, to transfer the PCF, PRRM, PSMF, and LSOF functionality from SRNC to DRNC. Iur shall be used also to collect RTD and other LCS information from base stations under different RNCs that are not involved in handover.

UTRAN Stage 2 specification 25.923 [1] specifies LCS signaling over the Iur interface.

7.4 Iub Interface, signaling between RNC, Node B and LMU

The Iub interface is used to communicate among the LCS entities associated with the serving RNC, the Node-B and the associated Location Measurement Units (LMU).

This interface passes the request for measurements, the measurement results and requests for LCS related transmissions or other radio operations needed by the location method (e.g. broadcast of parameters needed for a UE based location method).

The Iub interface may also pass messages relating to changes or reporting of the data associated with the Location System Operations Function (LSOF) in the Node-B or the LMU.

UTRAN Stage 2 specification 25.923 [1] specifies LCS signaling over the Iub interface.

7.4.1 Signaling between RNC and LMU in Node B

7.5 Uu Interface

The Uu interface is used to communicate among the LCS entities associated with the RNC, the MSs and the stand-alone Location Measurement Units (LMU). The Uu interface is also used to communicate between the LCS entities in the core network and the UE.

This interface may pass measurement requests and results to and from MS or the stand-alone LMU.

The Uu interface may also pass location requests from internal or external LCS Clients (Applications) at the MS. Note that these requests may require the services of the LCS entities associated with the core network to authenticate clients and subscriber subscriptions to aspects of the LCS.

The Uu interface may also be used for broadcast of information that may be used by the MS or stand-alone LMU for their LCS operations. This may, for example, include timing and code information about nearby Node-B transmissions that may assist the MS or LMU in making their measurements.

The Uu interface may also pass messages relating to changes or reporting of the data associated with the Location System Operations Function (LSOF) in the MS or the remote LMU.

7.5.1 Signaling between RNC and Target MS

TR 25.923 describes the signaling between RNC and Target MS and the necessary information to support the following location methods:

- OTDOA-IPDL
- GPS assisted, ie Network assisted, MS based (GPS) and Network based, MS assisted (GPS)
- Round trip time (RTT)

7.5.2 (Signaling between RNC and standalone LMU?)

7.6 Signaling Protocols

8 General network location procedures

8.1 State description for GMLC

8.2 State description for 3G-MSC/VLR

8.3 State description for 3G-SGSN

8.4 State description for RNC

The state description of RNC is in TR 25.923.

9 Information storage

10 Operational aspects

11 History

Date	Version	Comment
August 99	0.0.0	Initial Draft at Sophia Antipolis, France
September 99	0.0.1	Functional descriptions elaborated
September 99	0.1.0	Results from joint meeting R2/S2 21.9.99. Removed parts belonging to UTRAN stage 2 (25.923),
October 99	1.0.0	Identical to 0.1.0, except some editorial modifications.
Editor: Jan Käll Email: jan.kall@nokia.com Telephone: +358400 400056		

DEFINITIONS and terms

ANNEX 1

CAMEL	CAMEL is a network functionality, which provides the mechanisms of Intelligent Network to a mobile user.
Current Location	after a location attempt has successfully delivered a location estimate and its associated time stamp, the location estimate and time stamp is referred to as the 'current location' at that point in time.
Deferred location request	a location request where the location response (responses) is (are) not required immediately.
Global Positioning System.	The Global Positioning System (GPS) consists of three functional elements: Space Segment (satellites), User Segment (receivers), and Control Segment (maintenance etc.). The GPS receiver calculates its own position based on the received time differences for several satellites.
Immediate location request	a location request where a single location response only is required immediately.
Initial Location	in the context of an originating emergency call the location estimate and the associated time stamp at the commencement of the call set-up is referred to as 'initial location'.
Last Known Location	The current location estimate and its associated time stamp for Target MS stored in the LCS Server is referred to as the 'last known location' and until replaced by a later location estimate and a new time stamp is referred to as the 'last known location'.
LCS (LoCation Services)	LCS is a service concept in system (e.g. GSM or UMTS) standardization. LCS specifies all the necessary network elements and entities, their functionalities, interfaces, as well as communication messages, due to implement the positioning functionality in a cellular network. Note that LCS does not specify any location based (value added) services except locating of emergency calls
LCS Client	a software and/or hardware entity that interacts with a LCS Server for the purpose of obtaining location information for one or more Mobile Stations. LCS Clients subscribe to LCS in order to obtain location information. LCS Clients may or may not interact with human users. The LCS Client is responsible for formatting and presenting data and managing the user interface (dialogue). The LCS Client may reside in the Mobile Station (MS).
LCS Client Access barring list	an optional list of MSISDNs per LCS Client where the LCS Client is not allowed to locate any MSISDN therein.
LCS Client Subscription Profile	a collection of subscription attributes of LCS related parameters that have been agreed for a contractual period of time between the LCS client and the service provider.
LCS Feature	the capability of a PLMN to support LCS Client/server interactions for locating Target MSs.
LCS Server	a software and/or hardware entity offering LCS capabilities. The LCS Server accepts requests, services requests, and sends back responses to the received requests. The LCS server consists of LCS components, which are distributed to one or more PLMN and/or service provider.
Local Service	A service, which can be exclusively provided in the current serving network by a Value

	added Service Provider.
Local Information	Information related to a given location, or general information, which is made available in a given location.
Location (Based) Application	A location application is an application software processing location information or utilizing it in some way. The location information can be input by a user or detected by network or MS. Navigation is one location application example.
Location Based Service (LBS)	A service provided either by teleoperator or a 3 rd party service provider that utilizes the available location information of the terminal. Location Application offers the User Interface for the service. LBS is either a pull or a push type of service (see Location Dependent Services and Location Independent Services). In ETSI/GSM documentation of SoLSA, LBS is called "Location Related Service". ETSI and/or 3GPP –wide terminology harmonization is expected here.
Location Dependent Service	A service provided either by teleoperator or a 3 rd party service provider that is available (pull type) or is activated (push type) when the user arrives to a certain area. It doesn't require any subscription in advance, but the push type activation shall be confirmed by the user. The offered service itself can be any kind of service (e.g. a public Xerox machine or the discount list in a store).
Location Estimate	the geographic location of an MS and/or a valid Mobile Equipment (ME), expressed in latitude and longitude data. The Location Estimate shall be represented in a well-defined universal format. Translation from this universal format to another geographic location system may be supported, although the details are considered outside the scope of the primitive services.
Location Independent Service	A service provided either by teleoperator or a 3 rd party service provider that is available and therefore can be activated anywhere in the network coverage. It is activated by the user's request or by other user's activated service, and therefore it requires a subscription in advance (pull type). The offered service itself can be any kind of service (e.g. MMS, SWDL, or LBS!).
Mobile Station	The mobile station (MS) consists of Mobile or User Equipment (ME or UE) with a valid SIM or USIM attached.
PLMN Access barring list	an optional list of MSISDN per PLMN where any LCS Client is not allowed to locate any MSISDN therein except for certain exceptional cases.
Positioning (/location detecting)	Positioning is a functionality, which detects a geographical location (of e.g. a mobile terminal).
Positioning method (/locating method)	A principle and/or algorithm which the estimation of geographical location is based on, e.g. AOA, TOA, TDOA. For example, GPS is based on TOA, and E-OTD (on GSM) is based on TDOA.
Positioning technology (/locating technology)	A technology or system concept including the specifications of RF interfaces, data types, etc. to process the estimation of a geographical location, e.g. GPS, E-OTD (GSM), and IPDL-TDOA (WCDMA).
Predefined area	A geographical area which is not related to cell or radio coverage. The mobile may take special action when it recognises it has entered or left a predefined area.
Privacy Class	list of LCS Clients defined within a privacy exception class to which permission may be granted to locate the target MS. The permission shall be granted either on activation by the target MS or permanently for a contractual period of time agreed between the target MS and the service provider.
Privacy Exception	a list consisting of various types of privacy classes (i.e. operator related, personal etc.). Certain types of classes may require agreement between the service provider and the target

List	MS.
Prohibited area	An area where the mobile must not activate its transmitter. The Prohibited area may be a Predefined area described above or related to radio cell(s).
Subscription Profile	the profile detailing the subscription to various types of privacy classes.
Target MS	the MS being positioned.
UE	In vocabulary doc.