

TS 25.102 V3.0.0 (1999-10)

**3rd Generation Partnership Project (3GPP);
Technical Specification Group (TSG) RAN WG4;
UTRA (UE) TDD; Radio Transmission and Reception**



Reference

<Workitem> (<Shortfilename>.PDF)

Keywords

<keyword[, keyword]>

3GPP

Postal address

Office address

Internet

secretariat@3gpp.org
Individual copies of this deliverable
can be downloaded from
<http://www.3gpp.org>

Contents

Intellectual Property Rights	6
Foreword	6
1 Scope	7
2 References	7
3 Definitions, symbols and abbreviations	8
3.1 Definitions.....	8
3.2 Symbols.....	8
3.3 Abbreviations.....	9
4 General.....	10
4.1 Measurement uncertainty	10
5 Frequency bands and channel arrangement.....	11
5.1 General.....	11
5.2 Frequency bands	11
5.3 TX–RX frequency separation	11
5.4 Channel arrangement	11
5.4.1 Channel spacing	11
5.4.2 Channel raster.....	11
5.4.3 Channel number.....	11
6 Transmitter characteristics	13
6.1 General.....	13
6.2 Transmit power	13
6.2.1 User Equipment maximum output power	13
6.3 UE frequency stability.....	13
6.4 Output power dynamics	14
6.4.1 Open loop power control.....	14
6.4.2 Inner loop power control	14
6.4.3 Power control steps	14
6.4.3.1 Minimum Requirements.....	14
6.4.4 Power control cycles per second	14
6.4.4.1 Minimum Requirement	14
6.4.5 Minimum transmit output power	14
6.4.5.1 Minimum requirement	15
6.5 Transmit OFF power	15
6.5.1 Minimum Requirement.....	15
6.6 Output RF spectrum emissions.....	15
6.6.1 Occupied bandwidth.....	15
6.6.2 Out of band emission.....	15
6.6.2.1 Spectrum emission mask.....	15
6.6.2.1.1 Minimum Requirement	15
6.6.2.2 Adjacent Channel Leakage power Ratio (ACLR).....	16
6.6.2.2.1 Minimum requirement.....	16
6.6.3 Spurious emissions	16
6.6.3.1 Minimum Requirement	16
6.7 Transmit intermodulation.....	17
6.7.1 Minimum requirement	17
6.8 Transmit Modulation.....	17
6.8.1 Transmit pulse shape filter	17
6.8.2 Modulation Accuracy	17
6.8.2.1 Minimum Requirement	17
6.8.3 Peak Code Domain Error	17
6.8.3.1 Minimum Requirement	18

7	Receiver characteristics	19
7.1	General.....	19
7.2	Diversity characteristics	19
7.3	Reference sensitivity level	19
7.3.1	Minimum Requirements	19
7.4	Maximum input level	19
7.4.1	Minimum Requirements	19
7.5	Adjacent Channel Selectivity (ACS).....	20
7.5.1	Minimum Requirement.....	20
7.6	Blocking characteristics	20
7.6.1	Minimum Requirement.....	20
7.7	Spurious response	21
7.7.1	Minimum Requirement.....	21
7.8	Intermodulation characteristics	21
7.8.1	Minimum Requirements	22
7.9	Spurious emissions.....	22
7.9.1	Minimum Requirement.....	22
8	Performance requirement	23
8.1	General.....	23
8.2	Demodulation in static propagation conditions	23
8.2.1	Demodulation of DCH	23
8.2.1.1	Minimum requirement	23
8.2.2	Demodulation of BCH.....	23
8.2.2.1	Minimum requirement	24
8.3	Demodulation of DCH in multipath fading conditions	24
8.3.1	Multipath fading Case 1	24
8.3.1.1	Minimum requirement	24
8.3.2	Multipath fading Case 2	24
8.3.2.1	Minimum requirement	24
8.3.3	Multipath fading Case 3	24
8.3.3.1	Minimum requirement	25
8.4	Demodulation of BCH in multipath fading conditions.....	25
8.4.1	Multipath fading Case 1	25
8.4.1.1	Minimum requirement	25
8.5	Rx synchronisation characterisitics	26
8.5.1	Synchronization Performance.....	26
8.5.1.1	Search of other Cells.....	26
8.5.1.1.1	Minimum requirements	26
8.5.2	Inter-Frequency Handover.....	26
8.5.2.1	Minimum Requirements.....	26
8.6	Timing requirements	26
8.6.1	Synchronization.....	26
8.6.1.1	Minimum Requirements.....	26
Annex A	(normative): Measurement channels	27
A.1	General.....	27
A.2	Reference measurement channel	27
A.2.1	UL reference measurement channel (12.2 kbps)	27
A.2.2	DL reference measurement channel (12.2 kbps)	28
A.2.3	DL reference measurement channel (64 kbps)	29
A.2.4	DL reference measurement channel (144 kbps)	30
A.2.5	DL reference measurement channel (384 kbps)	31
A.2.6	BCH reference measurement channel.....	32
Annex B	(normative): Propagation conditions	33
B.2	Static propagation condition	33
B.2	Multi-path fading propagation conditions	33
Annex C	(normative): Environmental conditions.....	34
C.1	General.....	34
C.2	Environmental requirements for the UE.....	34

C.2.1	Temperature	34
C.2.2	Voltage	34
C.2.3	Vibration	35
Annex D (informative): Open items		36
ANNEX E (INFORMATIVE): Terminal Capabilities (TDD)		37
E.1	Baseline Implementation Capabilities	37
E.2	Service Implementation Capabilities	37
History		38

Intellectual Property Rights

IPRs essential or potentially essential to the present document may have been declared to ETSI. The information pertaining to these essential IPRs, if any, is publicly available for **ETSI members and non-members**, and can be found in ETR 314: "Intellectual Property Rights (IPRs); Essential, or potentially Essential, IPRs notified to ETSI in respect of ETSI standards", which is available **free of charge** from the ETSI Secretariat. Latest updates are available on the ETSI Web server (<http://www.etsi.fr/ipr>).

Pursuant to the ETSI Interim IPR Policy, no investigation, including IPR searches, has been carried out by ETSI. No guarantee can be given as to the existence of other IPRs not referenced in ETR 314 (or the updates on <http://www.etsi.fr/ipr>) which are, or may be, or may become, essential to the present document.

Foreword

This Technical Specification has been produced by the 3GPP.

The contents of the present document are subject to continuing work within the TSG and may change following formal TSG approval. Should the TSG modify the contents of this TS, it will be re-released by the TSG with an identifying change of release date and an increase in version number as follows:

Version 3.y.z

where:

x the first digit:

- 1 presented to TSG for information;
- 2 presented to TSG for approval;
- 3 Indicates TSG approved document under change control.

y the second digit is incremented for all changes of substance, i.e. technical enhancements, corrections, updates, etc.

z the third digit is incremented when editorial only changes have been incorporated in the specification;

1 Scope

This document establishes the minimum RF characteristics of the TDD mode of UTRA for the User Equipment (UE).

2 References

The following documents contain provisions, which, through reference in this text, constitute provisions of the present document.

- References are either specific (identified by date of publication, edition number, version number, etc.) or non-specific.
- For a specific reference, subsequent revisions do not apply.
- For a non-specific reference, subsequent revisions do apply.
- A non-specific reference to an ETS shall also be taken to refer to later versions published as an EN with the same number.

3 Definitions, symbols and abbreviations

3.1 Definitions

For the purposes of the present document, the following definitions apply:

Power Setting	The value of the control signal, which determines the desired transmitter, output Power. Typically, the power setting would be altered in response to power control commands
Maximum Power Setting	The highest value of the Power control setting which can be used.
Maximum output Power	This refers to the measure of power when averaged over the transmit timeslot at the maximum power setting.
Peak Power	The instantaneous power of the RF envelope which is not expected to be exceeded for [99.9%] of the time
Maximum peak power	The peak power observed when operating at a given maximum output power.
Average transmit power	The average transmitter output power obtained over any specified time interval, including periods with no transmission. <Editors: This definition would be relevant when considering realistic deployment scenarios where the power control setting may vary. >
Maximum average power	The average transmitter output power obtained over any specified time interval, including periods with no transmission, when the transmit time slots are at the maximum power setting. <Editors: The average power at the maximum power setting would also be consistent with defining a long term average power>
Received Signal Code Power (RSCP)	Given only signal power is received, the average power of the received signal after despreading and combining.
Interference Signal Code Power (ISCP)	Given only interference power is received, the average power of the received signal after despreading to the code and combining. Equivalent to the RSCP value but now only interference is received instead of signal

3.2 Symbols

For the purposes of the present document, the following symbols apply:

<symbol> <Explanation>

3.3 Abbreviations

For the purposes of the present document, the following abbreviations apply:

ACIR	Adjacent Channel Interference Ratio
ACLR	Adjacent Channel Leakage power Ratio
ACS	Adjacent Channel Selectivity
BS	Base Station
CW	Continuous wave (unmodulated signal)
DL	Down link (forward link)
DPCH	Dedicated physical channel
DPCH_Ec	Average energy per PN chip for DPCH
$\frac{DPCH_Ec}{I_{or}}$	The ratio of the average energy per PN chip of the DPCH to the total transmit power spectral density of the forward link at the BS antenna connector
EIRP	Effective Isotropic Radiated Power
FDD	Frequency Division Duplexing
FER	Frame Error Rate
I_{or}	The total transmit power spectral density of the Forward link at the BS antenna connector
\hat{I}_{or}	The received power spectral density of the Forward link as measured at the UE antenna connector
PPM	Parts Per Million
RSSI	Received Signal Strength Indicator
SIR	Signal to Interference ratio
TDD	Time Division Duplexing
TPC	Transmit Power Control
UE	User Equipment
UL	Up link (reverse link)
UTRA	UMTS Terrestrial Radio Access

4 General

4.1 Measurement uncertainty

The requirements given in these specifications are absolute. Compliance with these requirements are determined by comparing the measured values with the specified limits, without making allowance for measurement uncertainty.

5 Frequency bands and channel arrangement

5.1 General

The information presented in this section is based on a chip rate of 3.84 Mcps.

Note

1. Other chip rates may be considered in future releases.

5.2 Frequency bands

UTRA/TDD is designed to operate in the following bands;

- a) 1900 – 1920 MHz: Uplink and downlink transmission
2010 – 2025 MHz Uplink and downlink transmission
- b)* 1850 – 1910 MHz: Uplink and downlink transmission
1930 – 1990 MHz: Uplink and downlink transmission

Note: Appropriate adjustment is required for the parameters in the specified band

- c)* 1910 – 1930 MHz: Uplink and downlink transmission

Note: Appropriate adjustment is required for the parameters in the specified band

* Used in ITU Region 2

Additional allocations in ITU region 2 are FFS.

Deployment in other frequency bands is not precluded.

The co-existence of TDD and FDD in the same bands is still under study in WG4.

5.3 TX–RX frequency separation

No TX-RX frequency separation is required as Time Division Duplex (TDD) is employed. Each TDMA frame consists of 15 timeslots where each timeslot can be allocated to either transmit or receive.

5.4 Channel arrangement

5.4.1 Channel spacing

The nominal channel spacing is 5 MHz, but this can be adjusted to optimise performance in a particular deployment scenario.

5.4.2 Channel raster

The channel raster is 200 kHz, which means that the carrier frequency must be a multiple of 200 kHz.

5.4.3 Channel number

The carrier frequency is designated by the UTRA absolute radio frequency channel number (UARFCN). The value of the UARFCN in the IMT2000 band is defined as follows:

Lower IMT 2000 band:

$$N_t = 5 * (F - 1885.2)$$

$$1885.2 \leq F \leq 2024.8$$

where F is the carrier frequency in MHz

6 Transmitter characteristics

6.1 General

Unless detailed the transmitter characteristic are specified at the antenna connector of the UE. For UE with integral antenna only, a reference antenna with a gain of 0 dBi is assumed. Transmitter characteristics for UE(s) with multiple antennas/antenna connectors are FFS.

The UE antenna performance has a significant impact on system performance and minimum requirements on the antenna efficiency are therefore intended to be included in future versions of this specification. It is recognised that different requirements and test methods are likely to be required for the different types of UE.

All the parameters in section 6 are defined using the UL reference measurement channel (12.2 kbps) specified in Annex A.2.1.

6.2 Transmit power

6.2.1 User Equipment maximum output power

The following Power Classes define the maximum output power;

Table 6.1: UE power classes

Power Class	Maximum output power	Tolerance
1	+30 dBm	+1dB /-3dB
2	+24 dBm	+1dB /-3dB
3	+21 dBm	+2dB /-2dB]
4	+10 dBm	+4dB /-4dB

Note

1. The maximum output power refers to the measure of power when averaged over the useful part of the transmit timeslot at the maximum power control setting.
2. For multi-code operation the maximum output power will be reduced by the difference of peak to average ratio between single and multi-code transmission. The error of the maximum average power is below the prescribed value even at the multi-code transmission mode <new text is required to clarify this sentence>
3. Power class 4 is envisaged for licensed exempt operation.
4. For UE using directive antennas for transmission, a class dependent limit will be placed on the maximum EIRP (Equivalent Isotropic Radiated Power)..

6.3 UE frequency stability

The UE modulated carrier frequency shall be accurate to within ~~1~~ 0.1 PPM compared to carrier frequency received from the BS. These signals will have an apparent error due to BS frequency error and Doppler shift. In the later case, signals from the BS must be averaged over sufficient time that errors due to noise or interference are allowed for within the above ± 0.1 PPM figure.

Table 6.2: Frequency stability

AFC	Frequency stability
ON	within ± 0.1 PPM

6.4 Output power dynamics

Power control is used to limit the interference level.

6.4.1 Open loop power control

Open loop power control is the ability of the UE transmitter to sets its output power to a specified value. For the TDD mode the reciprocity of the channel allows accurate estimation of the required open loop transmit power.

The UE open loop power control error shall be less than ± 9 dB under normal conditions and ± 12 dB under extreme conditions.

6.4.2 Inner loop power control

Inner loop power control is the ability of the UE transmitter to adjust its output power in accordance to the TPC symbols received in the downlink.

6.4.3 Power control steps

The power control step is the step change in the UL transmitter output power in response to a TPC message. A set of power control steps is defined.

6.4.3.1 Minimum Requirements

The mobile station transmitter shall have the capability of setting power with a step of 1, 2 and 3dB. tolerance of the transmitter output power and the greatest average rate of change in mean power due to the power control step shall be within the range shown in Table 6.3.

Table 6.3: Power control step size tolerance

Step size	Tolerance	Range of average rate of change in mean power per 10 steps	
		minimum	maximum
1dB	± 0.5 dB	± 8 dB	± 12 dB
2dB	± 1 dB	± 16 dB	± 24 dB
3dB	± 1.5 dB	± 24 dB	± 36 dB

6.4.4 Power control cycles per second

The maximum and minimum rate of change for the UL transmitter power control step.

6.4.4.1 Minimum Requirement

The rate of change for the UL transmitter power control step is as follows: 100 – 800 Hz.

The minimum rate of 100 Hz is to ensure that every frame is power controlled. The maximum rate may differ for open and closed loop power control due to the used frame configuration.

6.4.5 Minimum transmit output power

The minimum controlled output power of the UE is when the power control setting is set to a minimum value. This is when both the closed loop and open loop power control indicates a minimum transmit output power is required.

6.4.5.1 Minimum requirement

The minimum transmit power shall be better than -44 dBm measured with a filter that has a root-raised cosine (RRC) filter response with a roll-off-factor $\alpha = 0.22$ and a bandwidth equal to the chip rate.

6.5 Transmit OFF power

The transmit OFF power state is when the UE does not transmit. This parameter is defined as the maximum output transmit power within the channel bandwidth when the transmitter is OFF.

6.5.1 Minimum Requirement

The requirement for transmit OFF power shall be better than -65 dBm measured with a filter that has a Root-Raised Cosine (RRC) filter response with a roll off $\alpha=0.22$ and a bandwidth equal to the chip rate.

6.6 Output RF spectrum emissions

6.6.1 Occupied bandwidth

Occupied bandwidth is a measure of the bandwidth containing 99% of the total integrated power of the transmitted spectrum, centred on the assigned channel frequency. The occupied channel bandwidth shall be less than 5 MHz based on a chip rate of 3.84 Mcps.

6.6.2 Out of band emission

Out of band emissions are unwanted emissions immediately outside the nominal channel resulting from the modulation process and non-linearity in the transmitter but excluding spurious emissions. This out of band emission limit is specified in terms of a spectrum emission mask and adjacent channel power ratio.

6.6.2.1 Spectrum emission mask

The spectrum emission mask of the UE applies to frequencies, which are between 2.5 and 12.5MHz from a carrier frequency. The out of channel emission is specified relative to the UE output power in measured in a 3.84 MHz bandwidth.

6.6.2.1.1 Minimum Requirement

The power of the 21dBm power class 3 UE emission shall not exceed the levels specified in table 6.4.

Table 6.4 : Spectrum Emission Mask Requirement

Frequency offset from carrier f	Minimum requirement	Measurement bandwidth
2.5 - 3.5 MHz	$-35 - 15*(\Delta f - 2.5)$ dBc	30 kHz *
3.5 - 7.5 MHz	$-35 - 1*(\Delta f - 3.5)$ dBc	1 MHz *
7.5 - 8.5 MHz	$-39 - 10*(\Delta f - 7.5)$ dBc	1 MHz *
8.5 - 12.5 MHz	-49 dBc	1 MHz *

Note

1. The first and last measurement position with a 30 kHz filter is 2.515 MHz and 3.485 MHz
2. The first and last measurement position with a 1 MHz filter is 4 MHz and 12 MHz
3. The lower limit shall be -50 dBm/3.84 MHz or which ever is the higher

6.6.2.2 Adjacent Channel Leakage power Ratio (ACLR)

Adjacent Channel Leakage power Ratio (ACLR) is the ratio of the transmitted power to the power measured after a receive filter in the adjacent channels(s). Both the transmitted power and the received power are measured with a filter response that has a Root-Raised Cosine (RRC) filter response with roll-off $\alpha = 0.22$ and a bandwidth equal to the chip rate.

6.6.2.2.1 Minimum requirement

The ACLR shall be better than the value specified in Table 6.5.

Table 6.5 :UE ACLR

Power Class	UE channel	ACLR limit
3	± 5 MHz	-33 dB or -50 dBm which ever is higher
3	± 10 MHz	-43 dB or -50 dBm which ever is higher

Note

1. The ACLR due to switching transients shall not exceed the limits in the above table.

6.6.3 Spurious emissions

Spurious emissions are emissions which are caused by unwanted transmitter effects such as harmonics emission, parasitic emission, intermodulation products and frequency conversion products, but exclude out of band emissions.

The frequency boundary and the detailed transitions of the limits between the requirement for out band emissions and spectrum emissions are based on ITU-R Recommendations SM.329.

6.6.3.1 Minimum Requirement

These requirements are only applicable for frequencies which are greater than 12.5 MHz away from the UE center carrier frequency.

Table 6.6a : General Spurious emissions requirements

Frequency Bandwidth	Resolution Bandwidth	Minimum requirement
$9 \text{ kHz} \leq f < 150 \text{ kHz}$	1 kHz	-36 dBm
$150 \text{ kHz} \leq f < 30 \text{ MHz}$	10 kHz	-36 dBm
$30 \text{ MHz} \leq f < 1000 \text{ MHz}$	100 kHz	-36 dBm
$1 \text{ GHz} \leq f < 12.75 \text{ GHz}$	1 MHz	-30 dBm

Table 6.6b : Additional Spurious emissions requirements

Frequency Bandwidth	Resolution Bandwidth	Minimum requirement
$925 \text{ MHz} \leq f \leq 935 \text{ MHz}$	100 KHz	-67 dBm*
$935 \text{ MHz} < f \leq 960 \text{ MHz}$	100 KHz	-79 dBm*
$1805 \text{ MHz} \leq f \leq 1880 \text{ MHz}$	100 KHz	-71 dBm*

Note

* The measurements are made on frequencies which are integer multiples of 200 kHz. As exceptions, up to five measurements with a level up to the applicable requirements defined in Table 6.6b are permitted for each UARFCN used in the measurement.

6.7 Transmit intermodulation

The transmit intermodulation performance is a measure of the capability of the transmitter to inhibit the generation of signals in its non linear elements caused by presence of the wanted signal and an interfering signal reaching the transmitter via the antenna.

6.7.1 Minimum requirement

User Equipment(s) transmitting in close vicinity of each other can produce intermodulation products, which can fall into the UE, or BS receive band as an unwanted interfering signal. The UE intermodulation attenuation is defined by the ratio of the output power of the wanted signal to the output power of the intermodulation product when an interfering CW signal is added at a level below the wanted signal. Both the wanted signal power and the intermodulation product power are measured with a filter response that is root-raised cosine (RRC) with roll-off $\alpha=0.22$ and with a bandwidth equal to the chip rate.

The requirement of transmitting intermodulation for carrier spacing 5 MHz is prescribed in the Table below.

Table 6.7 : Transmit Intermodulation

Interference Signal Frequency Offset	5MHz	10MHz
Interference Signal Level	-40 dBc	
Minimum Requirement	-31dBc	-41dBc

Note: This requirement is applicable to the 21 dBm power class 3 UE.

6.8 Transmit Modulation

6.8.1 Transmit pulse shape filter

The transmit pulse-shaping filter is a root-raised cosine (RRC) with roll-off $\alpha =0.22$ in the frequency domain. The impulse response of the chip impulse filter $RC_0(t)$ is

$$RC_0(t) = \frac{\sin\left(\frac{p}{T_c}t(1-a)\right) + 4a\frac{t}{T_c}\cos\left(\frac{p}{T_c}t(1+a)\right)}{\frac{p}{T_c}\left(1 - \left(4a\frac{t}{T_c}\right)^2\right)}$$

Where the roll-off factor $\alpha =0.22$ and the chip duration: $T_c = \frac{1}{\text{chiprate}} \approx 0.26042 \text{ms}$

6.8.2 Modulation Accuracy

The modulation accuracy is a measure of the difference between the measured waveform and the theoretical modulated waveform (the error vector). It is the square root of the ratio of the mean error vector power to the mean reference signal power expressed as a %. The measurement interval is one timeslot.

6.8.2.1 Minimum Requirement

The modulation accuracy shall not exceed 17.5 %.

6.8.3 Peak Code Domain Error

This specification is applicable for multi-code transmission only.

The code domain error is computed by projecting the error vector power onto the code domain at the maximum spreading factor. The error power for each code is defined as the ratio to the mean power of the reference waveform

expressed in dB. And the Peak Code Domain Error is defined as the maximum value for Code Domain Error. The measurement interval is one timeslot.

6.8.3.1 Minimum Requirement

The peak code domain error shall not exceed [] dB.

7 Receiver characteristics

7.1 General

Unless detailed the receiver characteristic are specified at the antenna connector of the UE. For UE with an integral antenna only, a reference antenna with a gain of 0 dBi is assumed. UE with an integral antenna may be taken into account by converting these power levels into field strength requirements, assuming a 0 dBi gain antenna. Receiver characteristics for UE(s) with multiple antennas/antenna connectors are FFS.

The UE antenna performance has a significant impact on system performance, and minimum requirements on the antenna efficiency are therefore intended to be included in future versions of this specification. It is recognised that different requirements and test methods are likely to be required for the different types of UE.

All the parameters in Section 7 are defined using the DL reference measurement channel specified in Annex A.2.2.

7.2 Diversity characteristics

A suitable receiver structure using coherent reception in both channel impulse response estimation, and code tracking procedures is assumed. Three forms of diversity are considered to be available in UTRA/TDD:

Table 6, Diversity characteristics for UTRA/TDD.

Table 7.1 : Diversity characteristics for UTRA/FDD

Time diversity	Channel coding and interleaving in both up link and down link
Multi-path diversity	Rake receiver or other suitable receiver structure with maximum combining. Additional processing elements can increase the delay-spread performance due to increased capture of signal energy.
Antenna diversity	Antenna diversity with maximum ratio combining in the base station and optionally in the mobile stations. Possibility for downlink transmit diversity in the base station.

7.3 Reference sensitivity level

The reference sensitivity is the minimum receiver input power measured at the antenna port at which the BIT Error Rate BER does not exceed a specific value.

7.3.1 Minimum Requirements

Table 7.2 : Reference sensitivity level

Data rate	UE reference sensitivity level (dBm)	FER/BER
12.2 kbps	-105 dBm	BER shall not exceed 0.001

7.4 Maximum input level

This is defined as the maximum receiver input power at the UE antenna port which does not degrade the specified BER performance.

7.4.1 Minimum Requirements

The BER shall not exceed 0.001 for the parameters specified in Table 7.3.

Table 7.3: Maximum input level

Parameter	Level	Unit
$\frac{DPCH_{Ec}}{I_{or}}$	-7	dB
\hat{I}_{or}	-25	dBm/3.84 MHz

7.5 Adjacent Channel Selectivity (ACS)

Adjacent Channel Selectivity is a measure of a receiver's ability to receive a wanted signal at its assigned channel frequency in the presence of adjacent channel signal at a given frequency offset from the centre frequency of the assigned channel. ACS is the ratio of the receive filter attenuation on the assigned channel frequency to the receiver filter attenuation on the adjacent channel(s).

7.5.1 Minimum Requirement

The BER shall not exceed 0.001 for the parameters specified in Table 7.4.

Table 7.4: Adjacent Channel Selectivity

Power Class	ACS	Units
3	[33]	dB

Parameter	Level	Unit
Data rate	12.2	kbps
Wanted signal	[]	dBm
Interfering signal	[]	dBm
Fuw (Modulated)	5	MHz

7.6 Blocking characteristics

The blocking characteristics is a measure of the receiver ability to receive a wanted signal at its assigned channel frequency in the presence of an unwanted interferer on frequencies other than those of the spurious response or the adjacent channels. The blocking performance shall apply at all frequencies except those at which a spurious response occur.

7.6.1 Minimum Requirement

The BER shall not exceed 0.001 for the parameters specified in table 7.5 and table 7.6. For table 13 up to 24 exceptions are allowed for spurious response frequencies in each assigned frequency channel when measured using a 1MHz step size.

Table 7.5: In-band blocking

Parameter	Offset	Offset	Unit
Wanted Signal Level	<REFSENS> + 3 dB	<REFSENS> + 3 dB	dBm/3.84 MHz
Unwanted Signal Level (modulated)	-56	-44	dBm/3.84 MHz
Blocking offset	$10 < f-f_0 < 15$	$ f-f_0 \geq 15$	MHz

Table 7.6: Out of band blocking

Parameter	Band 1	Band 2	Band 3	Unit
Wanted Signal Level	<REFSENS> + 3 dB	<REFSENS> + 3 dB	<REFSENS> + 3 dB	dBm/3.84 MHz
Unwanted Signal Level (CW)	-44	-30	-15	dBm
Blocking offset	1840 < f < 1885 1935 < f < 1995 2040 < f < 2095	1815 < f < 1840 2095 < f < 2120	1 < f < 1815 2120 < f < 12750	MHz

Note: On frequency regions 1885 < f < 1900 MHz, 1920 < f < 1935 MHz, 1995 < f < 2010 MHz and 2025 < f < 2040 MHz, the appropriate in-band blocking or adjacent channel selectivity in section 7.5.1 shall be applied.

7.7 Spurious response

Spurious response is a measure of the receiver's ability to receive a wanted signal on its assigned channel frequency without exceeding a given degradation due to the presence of an unwanted CW interfering signal at any other frequency at which a response is obtained i.e. for which the blocking limit is not met.

7.7.1 Minimum Requirement

The BER shall not exceed 0.001 for the parameters specified in Table 7.7.

Table 7.7: Spurious Response

Parameter	Level	Unit
Wanted Signal Level	<REFSENS> + 3 dB	dBm/3.84 MHz
Unwanted Signal Level (CW)	-44	dBm
F _{cw}	Spurious response frequencies	MHz

7.8 Intermodulation characteristics

Third and higher order mixing of the two interfering RF signals can produce an interfering signal in the band of the desired channel. Intermodulation response rejection is a measure of the capability of the receiver to receive a wanted signal on its assigned channel frequency in the presence of two or more interfering signals which have a specific frequency relationship to the wanted signal.

7.8.1 Minimum Requirements

The BER shall not exceed 0.001 for the parameters specified in table 7.8.

Table 7.8: Receive intermodulation characteristics

Parameter	Level	Unit
Wanted Signal Level	<REFSENS> + 3 dB	dBm/3.84 MHz
I _{ouw1}	-46	dBm
I _{ouw2}	-46	dBm/3.84 MHz
Fuw1 (CW)	10	MHz
Fuw2 (Modulated)	20	MHz

7.9 Spurious emissions

The Spurious Emissions Power is the power of emissions generated or amplified in a receiver that appear at the UE antenna connector.

7.9.1 Minimum Requirement

The spurious emission shall be:

1. Less than [-60dBm/ 3.84MHz] at the mobile station antenna connector, for frequencies within the UE receive band.
2. Less than [-57dBm/100kHz] at the mobile station antenna connector, for frequencies band from 9kHz to 1GHz.
3. Less than [-47dBm/100kHz] at the mobile station antenna connector, for frequencies band from 1GHz to 12.75GHz.

8 Performance requirement

8.1 General

The performance requirements for the UE in this section are specified for the measurement channels specified in Annex A and the propagation condition specified in Annex B.

Table 8.1: Summary of UE performance targets

Test Chs.	Information Data Rate	Static	Multi-path Case 1	Multi-path Case 2	Multi-path Case 3
		Performance metric			
DCH	12.2 kbps				
	64 kbps				
	144 kbps				
	384 kbps				
	2048 kbps				
BCH					

8.2 Demodulation in static propagation conditions

8.2.1 Demodulation of DCH

The performance requirement of DCH in static propagation conditions is determined by the maximum Block Error Rate (BLER). The BLER is specified for each individual data rate of the DCH.

8.2.1.1 Minimum requirement

The BLER should not exceed the limit for the E_b/N_0 specified in Table 8.2.

Table 8.2: Performance requirements in AWGN channel.

Measurement channel		
12.2 kbps		
64 kbps		
144 kbps		
384 kbps		
2048 kbps		

8.2.2 Demodulation of BCH

8.2.2.1 Minimum requirement

8.3 Demodulation of DCH in multipath fading conditions

8.3.1 Multipath fading Case 1

The performance requirement of DCH is determined by the maximum Block Error Rate (BLER). The BLER is specified for each individual data rate of the DCH.

8.3.1.1 Minimum requirement

The BLER should not exceed the limit for the E_b/N_0 specified in Table 8.3.

Table 8.3: Performance requirements in multipath Case 1 channel.

Measurement channel		
12.2 kbps		
64 kbps		
144 kbps		
384 kbps		
2048 kbps		

8.3.2 Multipath fading Case 2

The performance requirement of DCH is determined by the maximum Block Error Rate (BLER). The BLER is specified for each individual data rate of the DCH.

8.3.2.1 Minimum requirement

The BLER should not exceed the limit for the E_b/N_0 specified in Table 8.4.

Table 8.4: Performance requirements in multipath Case 2 channel.

Measurement channel		
12.2 kbps		
64 kbps		
144 kbps		
384 kbps		

8.3.3 Multipath fading Case 3

The performance requirement of DCH is determined by the maximum Block Error Rate (BLER). The BLER is specified for each individual data rate of the DCH.

8.3.3.1 Minimum requirement

The BLER should not exceed the limit for the E_b/N_0 specified in Table 8.5.

Table 8.5: Performance requirements in multipath Case 3 channel.

Measurement channel			
12.2 kbps			
64 kbps			
144 kbps			
384 kbps			

8.4 Demodulation of BCH in multipath fading conditions

8.4.1 Multipath fading Case 1

8.4.1.1 Minimum requirement

8.5 Rx synchronisation characteristics

8.5.1 Synchronization Performance

8.5.1.1 Search of other Cells

Search of other cells test is used to check whether the UE correctly searches and measures other BS(s) during the specified operation.

8.5.1.1.1 Minimum requirements

TBD

8.5.2 Inter-Frequency Handover.

The UE has to have the ability to make an Inter-frequency handover. This type of handover can happen within a BS or between two BS(s). Currently [ARIB Vol. 3] does not define requirements for Inter-frequency handover. <This item is ffs>

8.5.2.1 Minimum Requirements

TBD

8.6 Timing requirements

8.6.1 Synchronization

The timing of the UE is determined during specified operation.

8.6.1.1 Minimum Requirements

TBD

Annex A (normative): Measurement channels

A.1 General

A.2 Reference measurement channel

A.2.1 UL reference measurement channel (12.2 kbps)

Parameter	
Information data rate	12.2 kbps
RU's allocated	2 RU
Midamble	512 chips
Interleaving	20 ms
Power control	2 Bit/user
TFCI	16 Bit/user
Inband signalling DCCH	2 kbps
Puncturing level at Code rate 1/3 : DCH / DCCH	5% / 0%

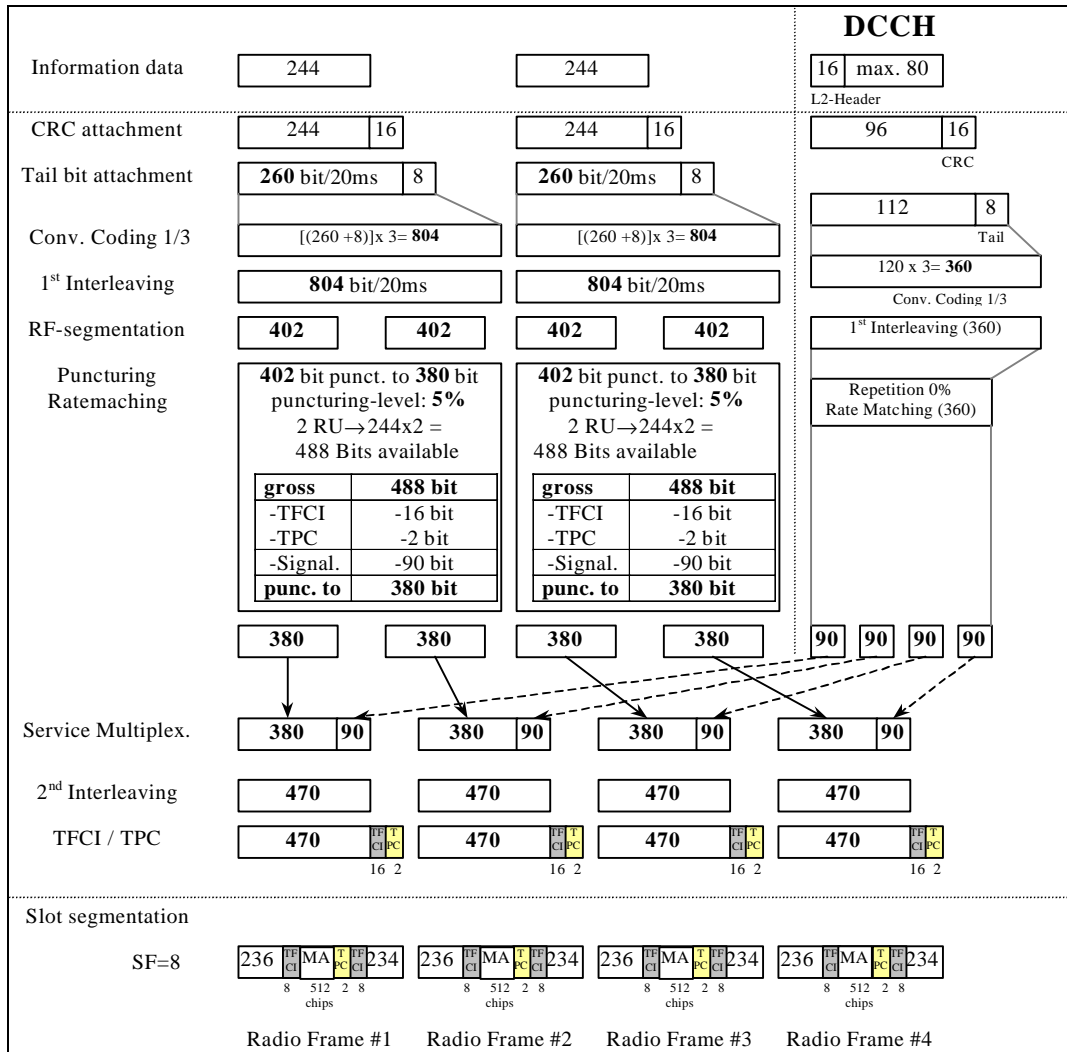

A.2.2 DL reference measurement channel (12.2 kbps)

Parameter	
Information data rate	12.2 kbps
RU's allocated	2 RU
Midamble	512 chips
Interleaving	20 ms
Power control	0 Bit/user
TFCI	16 Bit/user
Inband signalling DCCH	2 kbps
Puncturing level at Code rate 1/3 : DCH / DCCH	5% / 0 %

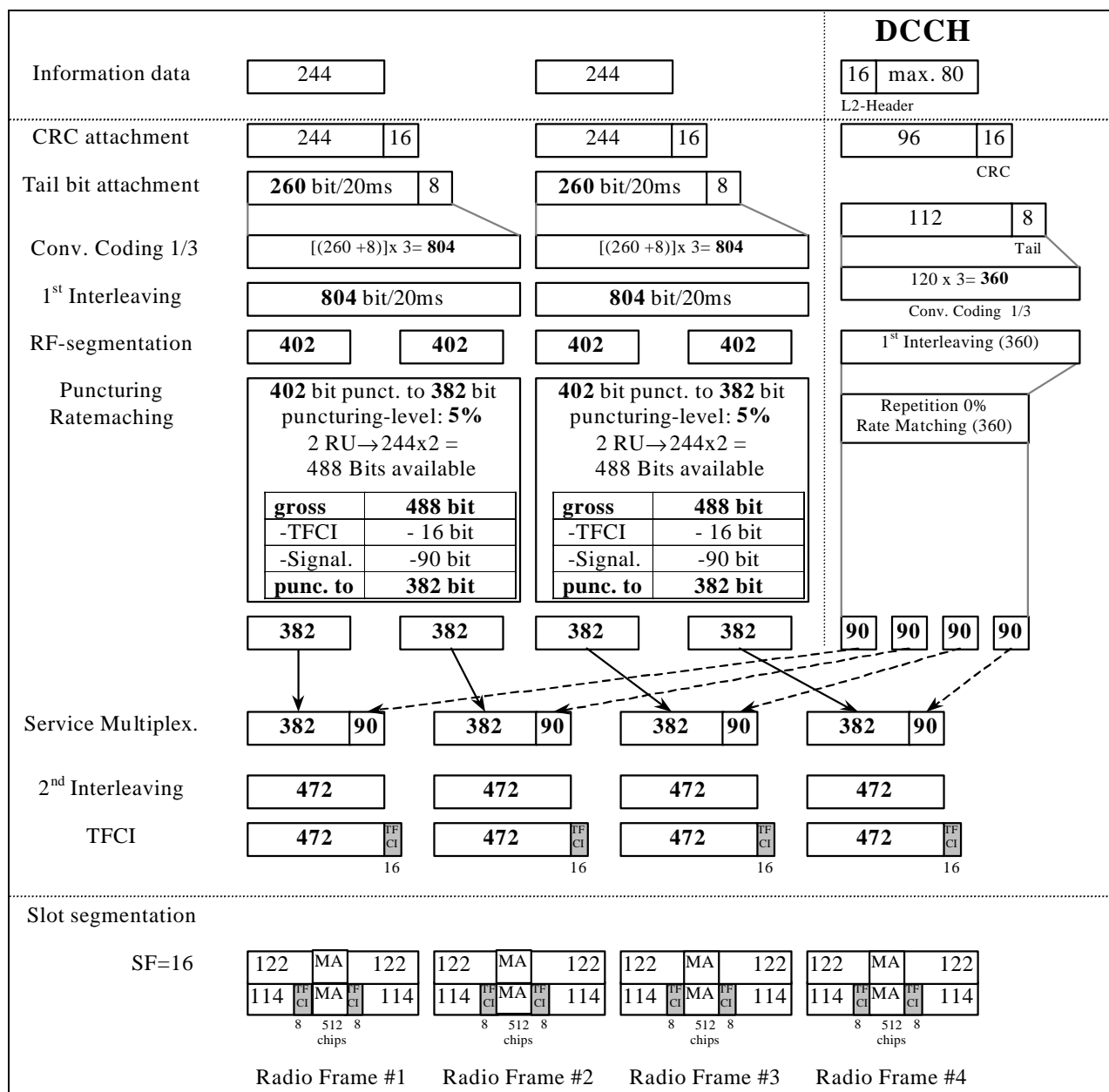

A.2.3 DL reference measurement channel (64 kbps)

Parameter	
Information data rate	64 kbps
RU's allocated	5 codes SF16 = 5RU
Midamble	512 chips
Interleaving	20 ms
Power control	0 Bit/user
TFCI	16 Bit/user
Inband signalling DCCH	2 kbps
Puncturing level at Code rate : 1/3 DCH / 1/2 DCCH	41.1% / 10%

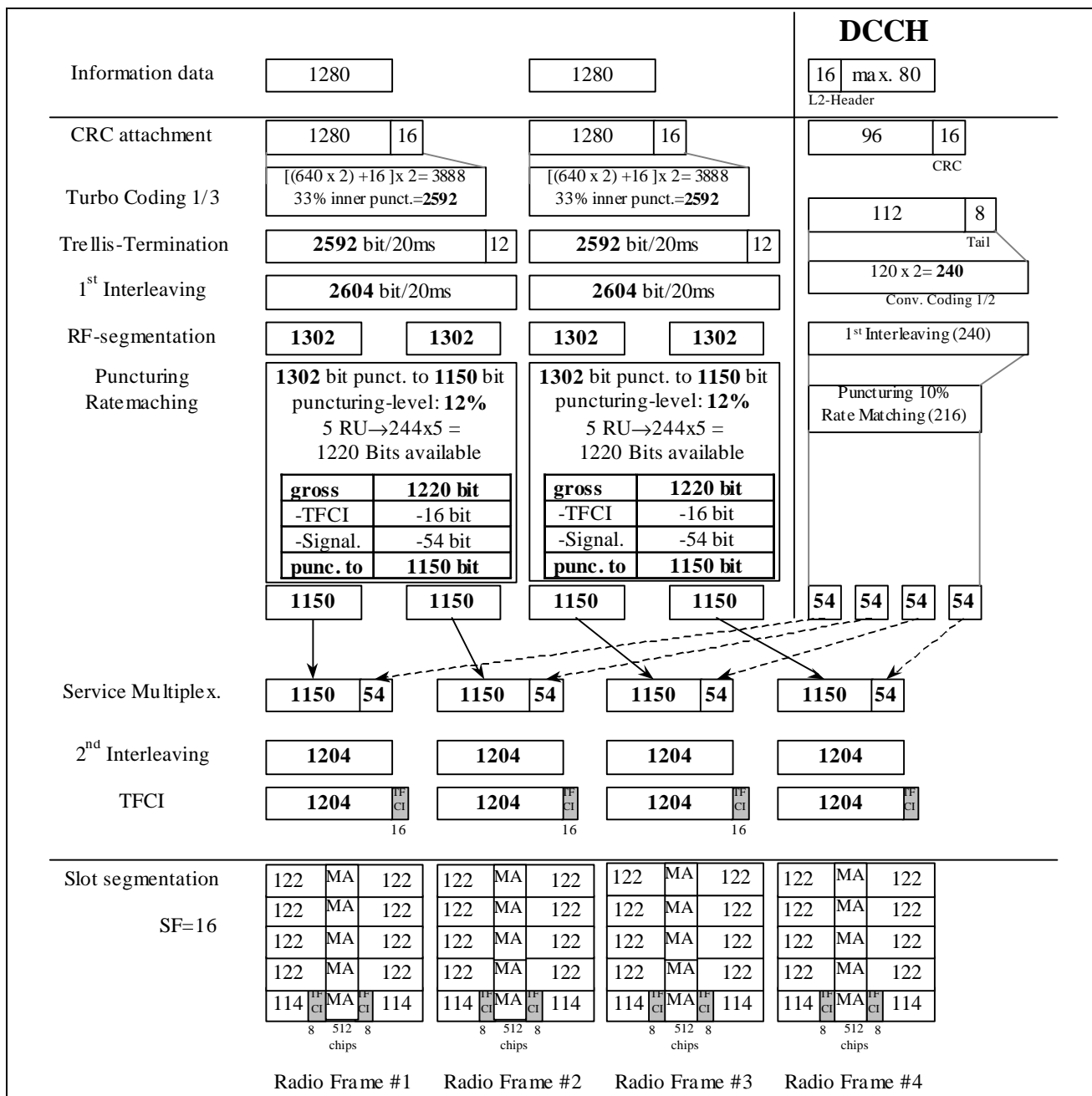

A.2.4 DL reference measurement channel (144 kbps)

Parameter	
Information data rate	144 kbps
RU's allocated	9 codes SF16 = 9RU
Midamble	256 chips
Interleaving	20 ms
Power control	0 Bit/user
TFCI	16 Bit/user
Inband signalling DCCH	2 kbps
Puncturing level at Code rate: 1/3 DCH / 1/2 DCCH	44.5% / 16.6%

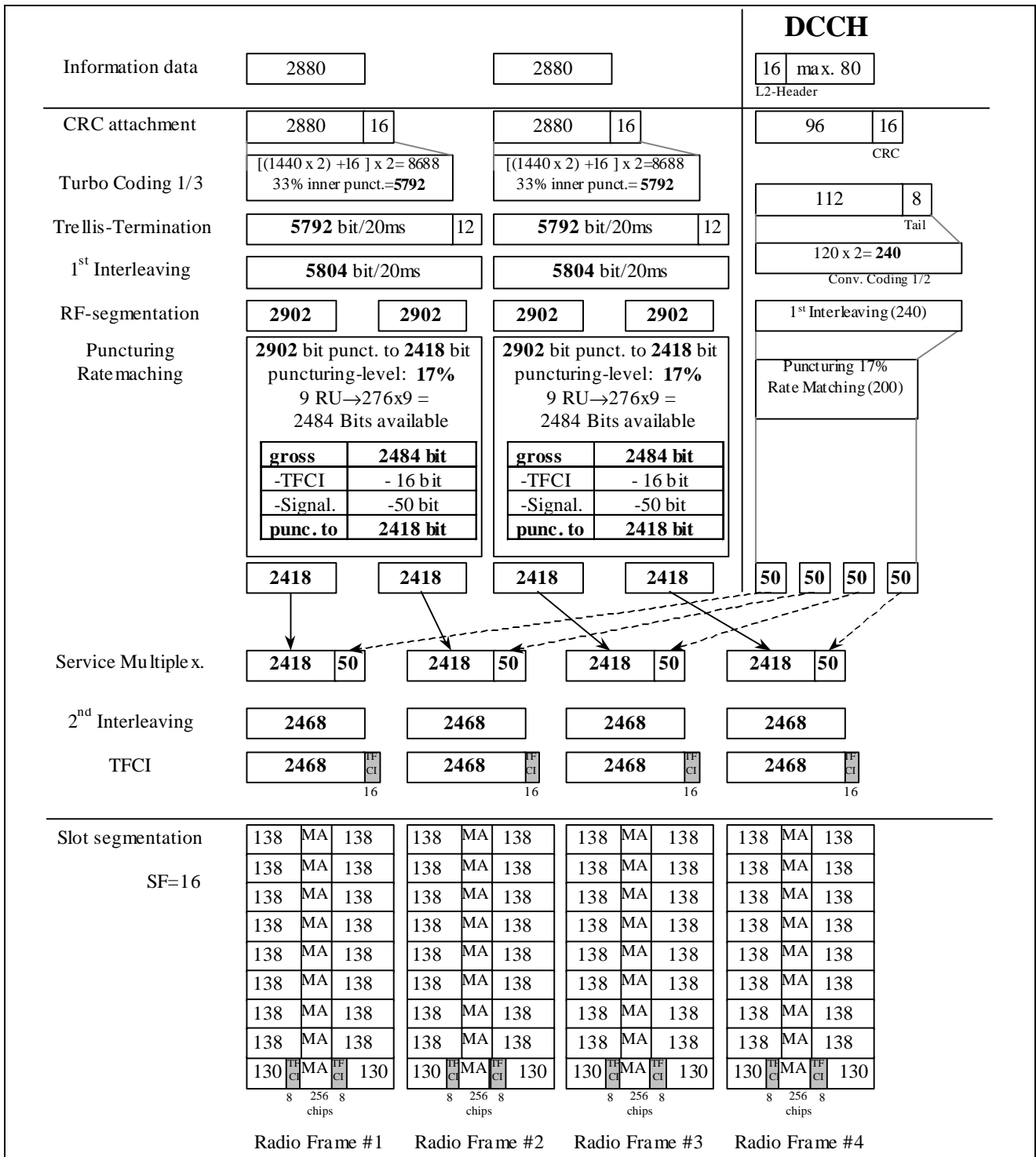

A.2.5 DL reference measurement channel (384 kbps)

Parameter	
Information data rate	384 kbps
RU's allocated	8*3TS = 24RU
Midamble	256 chips
Interleaving	20 ms
Power control	0 Bit/user
TFCI	16 Bit/user
Inband signalling DCCH	2 kbps
Puncturing level at Code rate : 1/3 DCH / 1/2 DCCH	43.4% / 15.3%

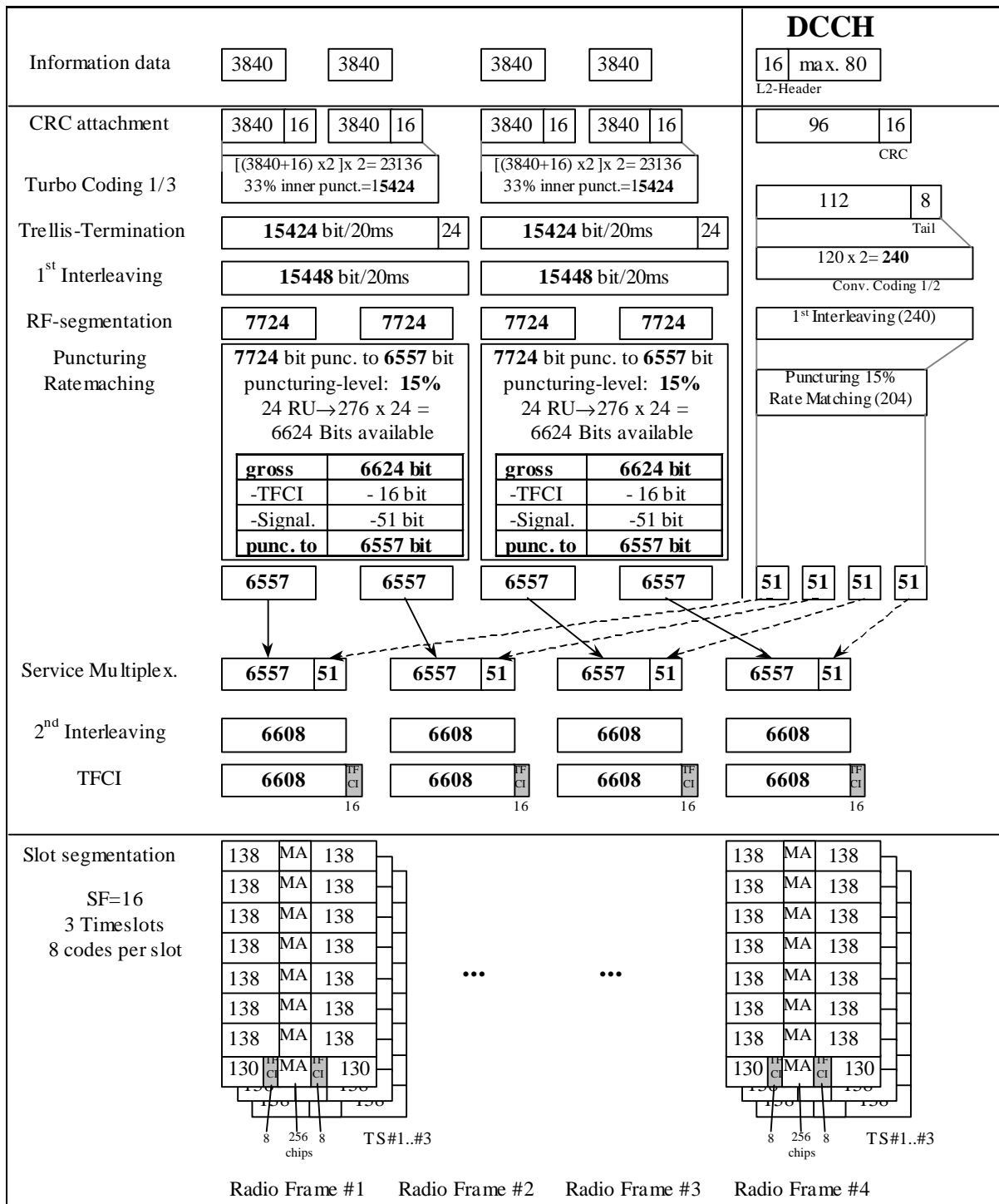

A.2.6 BCH reference measurement channel

[mapped to 1 code SF16]

Parameter	
<u>Information data rate:</u>	
0% puncturing rate at CR=1/2	11.0 kbps
10% puncturing rate at CR=1/2	12.4 kbps
$N_{BCH} = \frac{244 + N_{RM} - 24}{2}$	
RU's allocated	1 RU
Midamble	512 chips
Interleaving	20 ms
Power control	0 bit
TFCI	0 bit

N_{BCH} = number of bits per TB

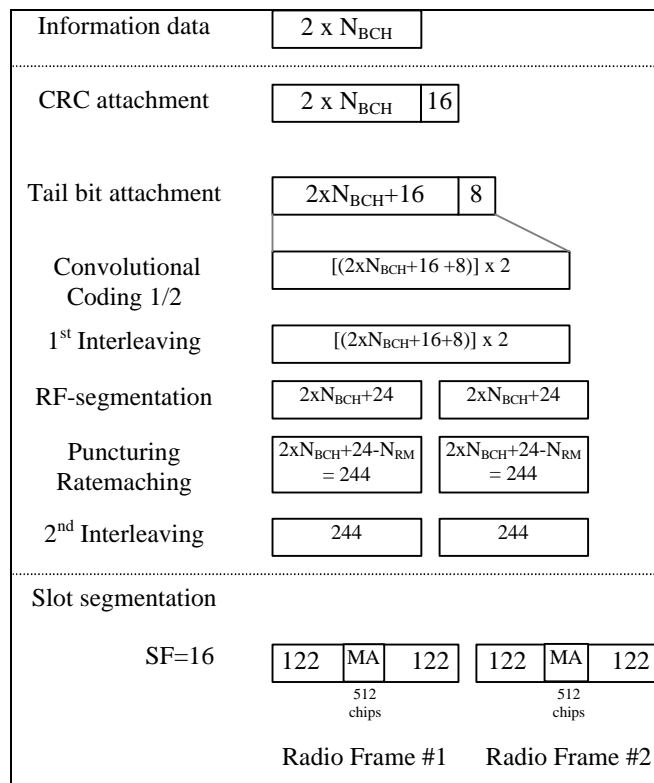

Annex B (normative): Propagation conditions

B.2 Static propagation condition

The propagation for the static performance measurement is an Additive White Gaussian Noise (AWGN) environment. No fading and multi-paths exist for this propagation model.

B.2 Multi-path fading propagation conditions

Table B2 shows propagation conditions that are used for the performance measurements in multi-path fading environment. All taps have classical Doppler spectrum.

Table B2: Propagation Conditions for Multi path Fading Environments

Case 1, speed 3km/h		Case 2, speed 3 km/h		Case 3, 120 km/h	
Relative Delay [ns]	Average Power [dB]	Relative Delay [ns]	Average Power [dB]	Relative Delay [ns]	Average Power [dB]
0	0	0	0	0	0
976	-10	976	0	260	-3
		20000	0	521	-6
				781	-9

Annex C (normative): Environmental conditions

C.1 General

This normative annex specifies the environmental requirements of the UE. Within these limits the requirements of this specifications shall be fulfilled.

C.2 Environmental requirements for the UE

The requirements in this clause apply to all types of UE(s)

C.2.1 Temperature

The UE shall fulfil all the requirements in the full temperature range of:

+15°C – +35°C	for normal conditions (with relative humidity of 25 % to 75 %);
-10°C - +55°C	for extreme conditions (see IEC publications 68-2-1 and 68-2-2)

Outside this temperature range the UE, if powered on, shall not make ineffective use of the radio frequency spectrum. In no case shall the UE exceed the transmitted levels as defined in S25.102 for extreme operation.

C.2.2 Voltage

The UE shall fulfil all the requirements in the full voltage range, i.e. the voltage range between the extreme voltages.

The manufacturer shall declare the lower and higher extreme voltages and the approximate shutdown voltage. For the equipment that can be operated from one or more of the power sources listed below, the lower extreme voltage shall not be higher, and the higher extreme voltage shall not be lower than that specified below.

Power source	Lower extreme voltage	Higher extreme voltage	Normal conditions voltage
AC mains	0,9 * nominal	1,1 * nominal	nominal
Regulated lead acid battery	0,9 * nominal	1,3 * nominal	1,1 * nominal
Non regulated batteries:			
- Leclanché/lithium	0,85 * nominal	Nominal	Nominal
- Mercury/nickel cadmium	0,90 * nominal	Nominal	Nominal

Outside this voltage range the UE if powered on, shall not make ineffective use of the radio frequency spectrum. In no case shall the UE exceed the transmitted levels as defined in S4.01A for extreme operation. In particular, the UE shall inhibit all RF transmissions when the power supply voltage is below the manufacturer declared shutdown voltage.

C.2.3 Vibration

The UE shall fulfil all the requirements when vibrated at the following frequency/amplitudes:

Frequency	ASD (Acceleration Spectral Density) random vibration
5 Hz to 20 Hz	0,96 m ² /s ³
20 Hz to 500 Hz	0,96 m ² /s ³ at 20 Hz, thereafter -3 dB/Octave

Outside the specified frequency range the UE, if powered on, shall not make ineffective use of the radio frequency spectrum. In no case shall the UE exceed the transmitted levels as defined in S4.01A for extreme operation.

Annex D (informative): Open items

Section number	Section description	Status
3	Definitions, Symbols, Abbreviations	Update required
5.2	Frequency bands	The deployment of TDD in the 1920 MHz to 1980 MHz band is an open item.
6.6.2.2.1	ACLR, Minimum requirement	The possibility is being considered of dynamically relaxing the ACP requirements for User Equipment(s) under conditions when this would not lead to significant interference (with respect to other system scenario or UMTS operators). This would be carried out under network control, primarily to facilitate reduction in UE power consumption.
6.7.2.1	Spectrum emission mask	Requirements for other than UE power class 21dBm
6.7.2.2	ACLR	Requirements for other than UE power class 21dBm
6.8	Transmit Intermodulation	Requirements for other than UE power class 21dBm
6.9.3	Peak Code Domain Error	Requirement to be defined.
7.5	ACS	Value in square brackets
7.9	Spurious Emissions	Values in square brackets
8	Performance Requirement	Values are TBD, update of structure needed.
Annex E2	Service Implementation Capabilities	For further study

ANNEX E (INFORMATIVE): Terminal Capabilities (TDD)

This section is based on the LS sent to TSG T2 on baseline terminal capabilities which has been updated to take into account changes in UE radio requirement specifications TS 25.102.

E.1 Baseline Implementation Capabilities

Capability TDD	Section	UE*	Comments
Chiprate 3.84 Mcps	5.1	M	
Frequency bands – 1900-1920 MHz – 2010-2025 MHz – Other spectrum	5.2	M M O	Declared 1900-1920 MHz Declared 2010-2025 MHz As Declared
Carrier raster	5.4	M	
UE maximum output power	6.2.1	M	At least one power class

(* M = mandatory, O = optional)

E.2 Service Implementation Capabilities

For further study.

History

Document history		
V0.0.1	1999-02-01	Document created based on S4.01A v0.0.2 "UTRA (UE) FDD, radio transmission
V0.0.2	1999-02-25	Editorial update after WG4#2 for distribution on the e-mail reflector.
V1.0.0	1999-03-02	Version presented to TSG RAN for information (identical to version 0.0.2)
V1.0.1	1999-04-13	Update according to decisions at TSG RAN WG4#3 in Tokyo, Japan, sent to WG4 e-mail reflector for comments
TS 25.102 V1.0.0	1999-04-23	Noted by TSG-RAN as TS 25.102 V1.0.0
V1.1.0	1999-04-23	Incorporation of agreed changes from WG4#4 Meeting in Kista.
V1.2.0	1999-07-06	Incorporation of agreed changes from WG4#5 Meeting in Miami.
V1.3.0	1999-08-09	Incorporation of agreed changes from WG4#6 Meeting in Edinburgh.
V2.0.0	1999-09-17	Incorporation of agreed changes from WG4#7 Meeting in Tokio.
V2.1.0	1999-10-04	Update after the TSG RAN WG4 AH01 simulation meeting in Noordwijkerhout. Sent to the reflector for comments in advance of TSG RAN#5.
V3.0.0	1999-10-07	Approved by TSG-RAN#5
<p>Editor for TS 25.102 is:</p> <p>Meik Kottkamp</p> <p>Siemens AG</p> <p>Tel: +49 89 722 36223</p> <p>Fax: +49 89 722 24450</p> <p>E-Mail: meik.kottkamp@icn.siemens.de</p> <p>This document is written in Microsoft Word 7</p>		