

**TSG-RAN Working Group 2 (Radio layer 2 and Radio layer 3)
Sophia Antipolis 16th to 20th July 1999**

TSGR2#6(99)907

Agenda Item: 5

Source: Rapporteur (CSELT)

Document for: Approval

Title: Results of the e-mail correspondence group on RRM



**3rd Generation Partnership Project;
Technical Specification Group RAN;
Working Group 2 (WG2)
Radio Resource Management Strategies
(3G TR 25.922 version 0.2.1)**

Reference

DTS/TSG<name abbrev>-0<WG no><spec no> U

Keywords

<keyword[, keyword]>

3GPP

Postal address

3GPP support office address

650 Route des Lucioles - Sophia Antipolis
Valbonne - FRANCE
Tel.: +33 4 92 94 42 00 Fax: +33 4 93 65 47 16

Internet

<http://www.3gpp.org>

Contents

Foreword.....	8
1 Scope	9
2 References	9
3 Definitions, symbols and abbreviations	9
3.1 Definitions.....	9
3.2 Symbols.....	9
3.3 Abbreviations.....	9
4 General Description of Radio Resource Management.....	12
5 Idle Mode Tasks	12
5.1 Overview.....	12
5.2 Service type in Idle mode.....	12
5.3 Criteria for Cell Selection and Reselection	12
5.3.1 Cell Selection Monitoring Frequency or Cell Set	12
5.3.2 Cell Re-Selection Monitoring Frequency or Cell Set.....	12
5.4 Location Registration.....	12
5.5 Broadcast information receiving	12
6 RRC Connection Mobility.....	13
6.1 General Description of Connected Mode.....	13
6.1.1 Handover.....	13
6.1.1.1 Strategy.....	13
6.1.1.2 Causes.....	13
6.1.1.3 Cell Set for the Handover Preparation	14
6.1.1.4 Hard Handover	14
6.1.1.4.1 Hard Handover (FDD and TDD Hard).....	14
6.1.1.5 Soft Handover.....	14
6.1.1.5.1 Soft Handover Parameters and definitions.....	14
6.1.1.5.2 General Scheme of Soft Handover Algorithm.....	14
6.1.1.5.3 Soft Handover Execution.....	16
6.1.1.6 Inter System Handover	18
6.1.1.6.1 Handover 3G to 2G.....	18
6.1.2 Radio Link Management.....	18
7 Admission Control.....	19
7.1 Overall strategies	19
7.2 Scenarios.....	20
7.2.1 CAC performed in SRNS	20
7.2.2 CAC performed in DRNC	20
7.2.2.1 Case of DCH.....	20
7.2.2.2 Case of Common Transport Channels	21
8 Radio Access Bearer Control	21
8.1 Radio Access Bearer Control – Overview of Procedures	21
8.2 Usage of RAB control procedures	22
8.2.1 Examples of Radio Access Bearer Setup.....	22
8.2.2 Examples of Physical Channel Reconfiguration.....	22
8.2.2.1 Increased UL data, with switch from RACH/FACH to DCH/DCH.....	22
8.2.2.2 Increased DL data, no Transport channel type switching	23
8.2.2.3 Decrease DL data, no Transport channel type switching	24
8.2.2.4 Decreased UL data, with switch from DCH/DCH to RACH/FACH.....	24
8.2.3 Examples of Transport Channel Reconfiguration.....	24
8.2.3.1 Increased UL data, with no transport channel type switching.....	25
8.2.3.2 Decreased DL data, with switch from DCH/DCH to RACH/FACH.....	25
8.2.4 Examples of RAB and Signalling link Reconfiguration	26
8.3 RRC Elementary Procedures.....	Error! Bookmark not defined.

9	Dynamic Channel Allocation	26
9.1	DCA (FDD)	26
9.2	DCA (TDD)	26
9.2.1	Channel Allocation	26
9.2.1.1	Resource allocation to cells (slow DCA)	26
9.2.1.2	Resource allocation to bearer services (fast DCA)	27
9.2.2	Measurements Reports from UE to the UTRAN	28
10	Power Management	28
10.1	Variable Rate Packet Transmission	28
10.1.1	Downlink Power Management	28
10.1.2	Uplink Power Management	28
10.2	Site Selection Diversity Power Control (SSDT)	29
11	Radio Link Surveillance	30
11.1	Mode Control strategies for tx diversity	30
11.1.1	TX diversity modes	30
11.1.2	Mode Control Strategies	30
11.1.2.1	DPCH	30
11.1.2.2	Common channels	30
12	Codec mode control	31
12.1	AMR mode control	31
13	Appendix A - (Simulations on Fast Dynamic Channel Allocation)	33
13.1	Simulation environment	33
13.2	Results	33
13.2.1	Macro UDD 144	33
13.2.2	Micro UDD 384	34
13.2.2.1	Code rate 1	34
13.2.2	Code rate 2/3	34
13.3	Conclusions	35
14	Appendix B (Radio Access Bearer Control – Overview of Procedures: message exchange and parameters used)	36
14.1	Examples of Radio Access Bearer Setup	36
14.1.1	RRC Parameters in RAB Setup	36
14.1.2	RRC Parameters in RAB Setup Complete	36
14.2	Examples of Physical Channel Reconfiguration	36
14.2.1	Increased UL data, with switch from RACH/FACH to DCH/DCH	36
14.2.1.1	RRC Parameters in Measurement Report	37
14.2.1.2	RRC Parameters in Physical Channel Reconfiguration	37
14.2.1.3	RRC Parameters in Physical Channel Reconfiguration Complete	37
14.2.2	Increased DL data, no Transport channel type switching	37
14.2.2.1	RRC Parameters in Physical Channel Reconfiguration	37
14.2.2.2	RRC Parameters in Physical Channel Reconfiguration Complete	38
14.2.3	Decrease DL data, no Transport channel type switching	38
14.2.3.1	RRC Parameters in Physical Channel Reconfiguration	38
14.2.3.2	RRC Parameters in Physical Channel Reconfiguration Complete	38
14.2.4	Decreased UL data, with switch from DCH/DCH to RACH/FACH	38
14.2.4.1	RRC Parameters in Physical Channel Reconfiguration	39
14.2.4.2	RRC Parameters in Physical Channel Reconfiguration Complete	39
14.3	Examples of Transport Channel Reconfiguration	39
14.3.1	Increased UL data, with no transport channel type switching	39
14.3.1.1	RRC Parameters in Measurement Report	39
14.3.1.2	RRC Parameters in Transport Channel Reconfiguration	39
14.3.1.3	RRC Parameters in Transport Channel Reconfiguration Complete	40
14.3.2	Decreased DL data, with switch from DCH/DCH to RACH/FACH	40
14.3.2.1	RRC Parameters in Transport Channel Reconfiguration	40
14.3.2.2	RRC Parameters in Transport Channel Reconfiguration Complete	40
14.4	Examples of RAB and Signalling link Reconfiguration	41
14.4.1	RRC Parameters in Radio access bearer reconfiguration	41

14.4.2	RRC Parameters in Radio access bearer reconfiguration Complete	41
15	Appendix C (Flow-chart of a general scheme of the Soft Handover algorithm)	41
16	Appendix D (SSDT performance).....	42
17	History	43
	Foreword.....	8
1	Scope	9
2	References	9
3	Definitions, symbols and abbreviations	9
3.1	Definitions.....	9
3.2	Symbols.....	9
3.3	Abbreviations.....	9
4	General Description of Radio Resource Management	12
5	Idle Mode Tasks	12
5.1	Overview.....	12
5.2	Service type in Idle mode.....	12
5.3	Criteria for Cell Selection and Reselection	12
5.3.1	Cell Selection Monitoring Frequency or Cell Set	12
5.3.2	Cell Re-Selection Monitoring Frequency or Cell Set.....	12
5.4	Location Registration.....	12
5.5	Broadcast information receiving.....	12
6	RRC Connection Mobility.....	13
6.1	General Description of Connected Mode.....	13
6.1.1	Handover	13
6.1.1.1	Strategy.....	13
6.1.1.2	Causes.....	13
6.1.1.3	Cell Set for the Handover Preparation.....	14
6.1.1.4	Hard Handover	14
6.1.1.4.1	Hard Handover (FDD and TDD Hard)	14
6.1.1.5	Soft Handover.....	14
6.1.1.6	Inter System Handover	18
6.1.1.6.1	Handover 3G to 2G.....	18
6.1.2	Radio Link Management.....	19
7	Admission Control.....	20
7.1	Overall strategies	20
7.2	Scenarios.....	20
7.2.1	CAC performed in SRNS.....	20
7.2.2	CAC performed in DRNC.....	21
7.2.2.1	Case of DCH.....	21
7.2.2.2	Case of Common Transport Channels	22
8	Radio Access Bearer Control	22
8.1	Radio Access Bearer Control Overview of Procedures	22
8.2	Usage of RAB control procedures	22
8.2.1	Examples of Radio Access Bearer Setup.....	23
8.2.2	Examples of Physical Channel Reconfiguration.....	23
8.2.2.1	Increased UL data, with switch from RACH/FACH to DCH/DCH.....	23
8.2.2.2	Increased DL data, no Transport channel type switching	24
8.2.2.3	Decrease DL data, no Transport channel type switching	24
8.2.2.4	Decreased UL data, with switch from DCH/DCH to RACH/FACH.....	25
8.2.3	Examples of Transport Channel Reconfiguration.....	25
8.2.3.1	Increased UL data, with no transport channel type switching.....	25
8.2.3.2	Decreased DL data, with switch from DCH/DCH to RACH/FACH.....	26
8.2.4	Examples of RAB and Signalling link Reconfiguration.....	26
8.3	RRC Elementary Procedures.....	27

9	Dynamic Channel Allocation	27
9.1	DCA (FDD)	27
9.1.1	Radio Resource Allocation Tasks (RACH/FACH and RACH+FAUSCH/FACH)	Error! Bookmark not defined.
9.1.2	Radio Resource Allocation tasks (DCH/DCH and DCH/DCH+DSCH)	Error! Bookmark not defined.
9.2	DCA (TDD)	27
9.2.1	Channel Allocation	27
9.2.1.1	Resource allocation to cells (slow DCA)	28
9.2.1.2	Resource allocation to bearer services (fast DCA)	28
9.2.2	Measurements Reports from UE to the UTRAN	29
10	Power Management	29
10.1	Variable Rate Packet Transmission	29
10.1.1	Downlink Power Management	29
10.1.2	Uplink Power Management	30
11	Radio Link Surveillance	30
12	Codec mode control	30
12.1	AMR mode control	30
13	Appendix A (Simulations on Fast Dynamic Channel Allocation)	32
13.1	Simulation environment	32
13.2	Results	32
13.2.1	Macro UDD 144	32
13.2.2	Micro UDD 384	33
13.2.2.1	Code rate 1	33
13.2.2.2	Code rate 2/3	34
13.3	Conclusions	34
14	Appendix B (Radio Access Bearer Control — Overview of Procedures: message exchange and parameters used)	35
14.1	Examples of Radio Access Bearer Setup	35
14.1.1	RRC Parameters in RAB Setup	35
14.1.2	RRC Parameters in RAB Setup Complete	35
14.2	Examples of Physical Channel Reconfiguration	35
14.2.1	Increased UL data, with switch from RACH/FACH to DCH/DCH	36
14.2.1.1	RRC Parameters in Measurement Report	36
14.2.1.2	RRC Parameters in Physical Channel Reconfiguration	36
14.2.1.3	RRC Parameters in Physical Channel Reconfiguration Complete	36
14.2.2	Increased DL data, no Transport channel type switching	37
14.2.2.1	RRC Parameters in Physical Channel Reconfiguration	37
14.2.2.2	RRC Parameters in Physical Channel Reconfiguration Complete	37
14.2.3	Decrease DL data, no Transport channel type switching	37
14.2.3.1	RRC Parameters in Physical Channel Reconfiguration	37
14.2.3.2	RRC Parameters in Physical Channel Reconfiguration Complete	37
14.2.4	Decreased UL data, with switch from DCH/DCH to RACH/FACH	38
14.2.4.1	RRC Parameters in Physical Channel Reconfiguration	38
14.2.4.2	RRC Parameters in Physical Channel Reconfiguration Complete	38
14.3	Examples of Transport Channel Reconfiguration	38
14.3.1	Increased UL data, with no transport channel type switching	38
14.3.1.1	RRC Parameters in Measurement Report	39
14.3.1.2	RRC Parameters in Transport Channel Reconfiguration	39
14.3.1.3	RRC Parameters in Transport Channel Reconfiguration Complete	39
14.3.2	Decreased DL data, with switch from DCH/DCH to RACH/FACH	39
14.3.2.1	RRC Parameters in Transport Channel Reconfiguration	40
14.3.2.2	RRC Parameters in Transport Channel Reconfiguration Complete	40
14.4	Examples of RAB and Signalling link Reconfiguration	40
14.4.1	RRC Parameters in Radio access bearer reconfiguration	41
14.4.2	RRC Parameters in Radio access bearer reconfiguration Complete	41
15	History	42

Foreword

This Technical Specification has been produced by the 3GPP.

The contents of the present document are subject to continuing work within the TSG and may change following formal TSG approval. Should the TSG modify the contents of this TS, it will be re-released by the TSG with an identifying change of release date and an increase in version number as follows;

Version x.y.z

where:

- x the first digit:
 - 1 presented to TSG for information;
 - 2 presented to TSG for approval;
 - 3 Indicates TSG approved document under change control.
- y the second digit is incremented for all changes of substance, i.e. technical enhancements, corrections, updates, etc.
- z the third digit is incremented when editorial only changes have been incorporated in the specification;

1 Scope

The present document shall describe RRM strategies supported by UTRAN specifications and typical algorithms.

2 References

The following documents contain provisions which, through reference in this text, constitute provisions of the present document.

- References are either specific (identified by date of publication, edition number, version number, etc.) or non-specific.
- For a specific reference, subsequent revisions do not apply.
- For a non-specific reference, the latest version applies.
- A non-specific reference to an ETS shall also be taken to refer to later versions published as an EN with the same number.

[1] 3GPP Homepage: www.3gpp.org

[2] TS25.301, Radio Interface Protocol Architecture

[3] TS25.302, Layer 1; General requirements

[4] TS25.303, UE States and Procedures in Connected Mode

[5] TS25.304, Description of procedures in idle Mode

[6] TS25.322, Description of RLC protocol

[7] TS25.331, Description of RRC protocol

[8] TS25.391, Description of principles for error handling and message description

[9] ETSI UMTS 25.XX: "Vocabulary for the UTRAN"

[10] S25.231, Physical layer Measurements

[11] TS 26.010, Mandatory Speech Codec speech processing functions AMR Speech Codec; General Description

3 Definitions, symbols and abbreviations

3.1 Definitions

See [9] for a definition of fundamental concepts and vocabulary.

3.2 Symbols

For the purposes of the present document, the following symbols apply:

3.3 Abbreviations

For the purposes of the present document, the following abbreviations apply:

ARQ Automatic Repeat Request

BCCH Broadcast Control Channel

BCH Broadcast Channel

C- Control-

CC	Call Control
CCCH	Common Control Channel
CCH	Control Channel
CCTrCH	Coded Composite Transport Channel
CN	Core Network
CRC	Cyclic Redundancy Check
DC	Dedicated Control (SAP)
DCA	Dynamic Channel Allocation
DCCH	Dedicated Control Channel
DCH	Dedicated Channel
DL	Downlink
DRNC	Drift Radio Network Controller
DSCH	Downlink Shared Channel
DTCH	Dedicated Traffic Channel
FACH	Forward Link Access Channel
FAUSCH	Fast Uplink Signalling Channel
FCS	Frame Check Sequence
FDD	Frequency Division Duplex
GC	General Control (SAP)
HO	Handover
ITU	International Telecommunication Union
kbps	kilo-bits per second
L1	Layer 1 (physical layer)
L2	Layer 2 (data link layer)
L3	Layer 3 (network layer)
LAC	Link Access Control
LAI	Location Area Identity
MAC	Medium Access Control
MM	Mobility Management
Nt	Notification (SAP)
OCCCH	ODMA Common Control Channel
ODCCH	ODMA Dedicated Control Channel
ODCH	ODMA Dedicated Channel
ODMA	Opportunity Driven Multiple Access

ORACH	ODMA Random Access Channel
ODTCH	ODMA Dedicated Traffic Channel
PCCH	Paging Control Channel
PCH	Paging Channel
PDU	Protocol Data Unit
PHY	Physical layer
PhyCH	Physical Channels
RACH	Random Access Channel
RLC	Radio Link Control
RNC	Radio Network Controller
RNS	Radio Network Subsystem
RNTI	Radio Network Temporary Identity
RRC	Radio Resource Control
SAP	Service Access Point
SCCH	Synchronization Control Channel
SCH	Synchronization Channel
SDU	Service Data Unit
SRNC	Serving Radio Network Controller
SRNS	Serving Radio Network Subsystem
TCH	Traffic Channel
TDD	Time Division Duplex
TFCI	Transport Format Combination Indicator
TFI	Transport Format Indicator
TMSI	Temporary Mobile Subscriber Identity
TPC	Transmit Power Control
U-	User-
UE	User Equipment
UE _R	User Equipment with ODMA relay operation enabled
UL	Uplink
UMTS	Universal Mobile Telecommunications System
URA	UTRAN Registration Area
UTRA	UMTS Terrestrial Radio Access
UTRAN	UMTS Terrestrial Radio Access Network

4 General Description of Radio Resource Management

5 Idle Mode Tasks

5.1 Overview

[A complete overview of idle mode tasks is contained in section 4.1 of S25.304. For the purpose of this recommendation some specific test will be developed.]

5.2 Service type in Idle mode

[In this section, the impact of service type on RRM strategies will be addressed, also based on section 4.3 of S25.304] Services are distinguished into categories defined in section 4.3 of TS 25.304; also the categorisation of cells according to services they can offer is provided in section 4.3 of TS 25.304. In the following, some typical examples of the use of the different types of cells are provided.

Low priority suitable cells.

These may be used for the support of multilayered networks.

“operator only” cell.

The aim of this type of cell is to allow the operator using and test newly deployed cells without being disturbed by normal traffic.

5.3 Criteria for Cell Selection and Reselection

5.3.14 Cell Selection Monitoring Frequency or Cell Set

5.3.25 Cell Re-Selection Monitoring Frequency or Cell Set

5.4 Location Registration

The location registration procedure is defined in TS 25.304. The strategy used for the update of the location registration has to be set by the operator and, for instance, can be done regularly and when entering a new registration area. The same would apply for the update of the NAS defined service area which can be performed regularly and when entering a new NAS defined service area.

5.5 Broadcast information receiving

[In this section the possible uses of broadcast system information on RRM strategies will be addressed also based on section 6 of S25.304]

6 RRC Connection Mobility

6.1 General Description of Connected Mode

[The overall description of the connected mode is contained in section 4 of S25.303. For the purpose of this recommendation some specific test will be developed.]

6.1.1 Handover

6.1.1.1 Strategy

The handover strategy employed by the network for radio link control determines the handover decision that will be made based on the measurement results reported by the UE/RNC and various parameters set for each cell. Network directed handover might also occur for reasons other than radio link control, e.g. to control traffic distribution between cells. The network operator will determine the exact handover strategies.. Possible types of Handover are as follows:

- Handover 3G -3G:
- FDD soft/softer handover;
- FDD inter-frequency hard handover;
- FDD/TDD Handover;
- TDD/FDD Handover;
- TDD/TDD Handover;
- Handover 3G - 2G:
- Handover to GSM

6.1.1.2 Causes

The following is a non-exhaustive list for causes for the initiation of a handover process.

- Uplink quality
- Uplink signal strength
- Downlink quality
- Downlink signal strength
- Distance
- Change of service
- Better cell
- O&M intervention
- Directed retry
- Traffic
- Pre-emption

6.1.1.3 Cell Set for the Handover Preparation

6.1.1.4 Hard Handover

6.1.1.4.1 Hard Handover (FDD and TDD Hard)

[Test to be deployed also based on section 7.3.7 of S25.303]

The hard handover procedure is defined in section 7.3.7 of TS 25.303.

Two main strategies can be used in order to determine the need for an hard handover:

- received measurements reports
- load control

6.1.1.5 Soft Handover

6.1.1.5.1 Soft Handover Parameters and definitions

Soft Handover is an handover in which the mobile station starts communication with a new BS on a same carrier frequency, or sector of the same site (softer handover), performing utmost a change of code. For this reason Soft Handover allows easily the provision of macrodiversity transmission; for this intrinsic characteristic terminology tends to identify Soft Handover with macrodiversity even if they are two different concepts; for its nature soft handover is used in CDMA systems where the same frequency is assigned to adjacent cells. As a result of this definition there are areas of the UE operation in which the UE is connected to a number of BSs. With reference to Soft Handover, the "Active Set" is defined as the set of BSs the UE is simultaneously connected to (i.e., the UTRA cells currently assigning a downlink DPCH to the UE constitute the active set).

The Soft Handover procedure is composed of a number of single functions:

- Measurements;
- Filtering of Measurements;
- Reporting of Measurement results;
- The Soft Handover Algorithm;
- Execution of Handover.

The reminder of the document focuses on the Soft Handover Algorithm. The measurements of the monitored cells filtered in a suitable way constitute the basic input of the Soft Handover Algorithm.

In order to exhaustively describe the Soft Handover Algorithm the following definitions are relevant:

"Candidate Set": the cells that are not currently in the Active Set but have been received by the UE with sufficient strength to indicate that the associated DPCH could be successfully demodulated.

"Neighbor Set": the cells that are not currently in the Active Set or the Candidate Set but are likely candidates for handoff.

Based on the measurements of the set of cells monitored, the Soft Handover function evaluates if any BS should be added to ("add"), removed from ("drop"), or replaced in ("rep") the Active Set; performing than what is known as "Active Set Update" procedure.

6.1.1.5.2 General Scheme of Soft Handover Algorithm

For the description of a general Scheme of Soft Handover algorithm the definition of the following parameters is needed:

AS_Th: Threshold for macro diversity;

AS_Th_Hyst: Hysteresis for the threshold;

AS_Rep_Hyst: Replacement Hysteresis;

AS_Max_Size: Maximum size of Active Set

The following figure describes the meaning of this parameters. In the following figure the Signal Strength is used as a criterion; this is simply an example: other criteria (e.g. SIR) can be considered.

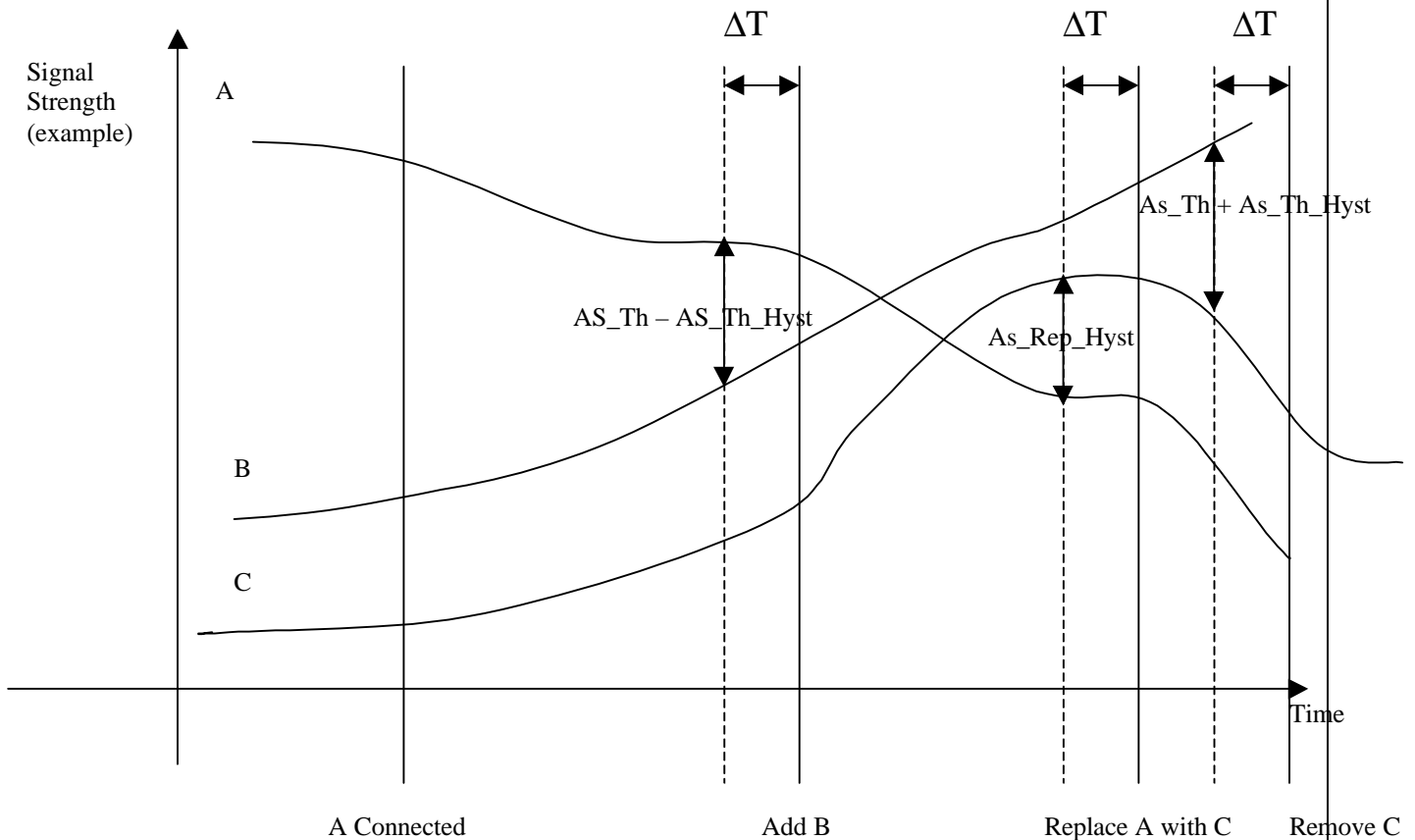

In the above figure, the following definitions are used:

- Best_Ss: the highest measured cell present in the Active Set;
- Worst_Old_Ss: the lowest measured cell present in the Active Set;
- Best_Cand_Set: the highest measured cell present in the candidate set.
- Meas_Sign: the measured and filtered signal strength.

As described in the figure above:

- If Meas_Sign is below $(\text{Best_Ss} - \text{AS_Th} - \text{AS_Th_Hyst})$ for a period of ΔT remove Worst BS in the Active Set.
- If Meas_Sign is greater than $(\text{Best_Ss} - \text{AS_Th} + \text{AS_Th_Hyst})$ for a period of ΔT and the Active Set is not full add Best BS outside the Active Set in the Active Set.
- If Active Set is full and Best_Cand_Ss is greater than $(\text{Worst_Old_Ss} + \text{AS_Rep_Hyst})$ for a period of ΔT add best BS outside Active Set and Remove Worst BS in the Active Set.

A flow-chart of the general scheme of the Soft Handover algorithm presented above is available in Annex C.

6.1.1.5.3 Soft Handover Execution

The serving cell (s) (the cells in the active set) are expected to have knowledge of the service used by the UE. The new cell decided to be added to the active set shall be informed that a new connection is desired, and it needs to have the following minimum information forwarded to it via UTRAN.

- Maximum data rate of the connection and other service parameters, such as coding schemes, number of parallel code channels etc. parameters which form the set of parameters describing the different transport channel configurations in use both uplink and downlink.
- The UE ID and uplink scrambling code
- The relative timing information of the new cell, in respect to the timing UE is experiencing from the existing connections (as measured by the UE at its location). Based on this the new cell can determine what should be the timing of the transmission initiated in respect to the timing of the common channels (BCCH) of the new cell.

As a response the UE needs to know via the existing connections:

- From which frame (assuming active set update accepted) does the new cell initiate the transmission to the UE
- What channelisation code(s) are used for that transmission. The channelisation codes from different cells are not required to be the same as they are under different scrambling code anyway.
- The relative timing information, which needs to be made available at the new cell is indicated in Figure 1 (shows the case where the two involved cells are managed by different Node Bs).

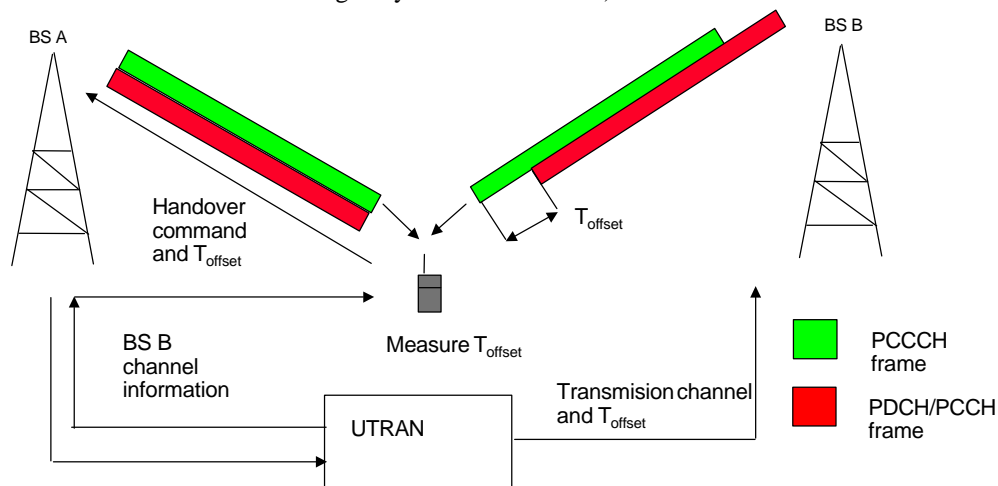

Figure 1. Making transmissions capable to be combined in the Rake receiver from timing point of view.

At the start of diversity handover, the reverse link dedicated physical channel transmitted by the MS, and the forward link dedicated physical channel transmitted by the diversity handover source BTS will have their radio frame number and scrambling code phase counted up continuously as usual, and they will not change at all. Naturally, the continuity of the user information mounted on them will also be guaranteed, and will not cause any interruption.

[Editor's Note: it is F.F.S if the following parts on synchronization are relevant for TR 25.922]

<Editor's note : text from ARIB, volume 3>

The synchronization timing upon starting diversity handover are presented in Fig. 3.2.5-4. The synchronisation establishment flow upon intra/inter-cell diversity handover is described in Fig. 3.2.6-4.

The MS measures the frame time difference of the radio frame at the same frame number between the reverse link dedicated physical channel and the perch channel transmitted at the handover destination BTS. These measurements shall be notified to the network. The measured value is the time difference of the frame timing of the reverse link

dedicated physical channel against the frame timing of the perch channel. The values shall always be positive values in chip units, and the range shall be 0 ~ “reverse link scrambling code cycle-1” chip.

The MS notifies the frame time difference measurement values as layer 3 signals to the BSC via the diversity handover source BTS with the DCH of the reverse link dedicated physical channel.

The BSC notifies the frame time difference measurement result, together with the frame offset and slot offset set up upon originating/ terminating call connection, to the diversity handover destination BTS with layer 3 signals.

Furthermore, the BSC notifies radio parameters such as the spreading codes used at the handover destination BTS etc., to the MS via the handover source BTS.

The MS starts the chip synchronisation establishment process of forward link channel from the handover destination BTS with the notified radio parameters. The reverse link channels being transmitted shall continue transmission without any operations performed.

The handover destination BTS receives the notification of the above frame time difference frame offset, and slot offset. Utilising these informations, the BTS starts the transmission of forward link dedicated physical channels and starts the synchronization establishment process of reverse link dedicated physical channel transmitted by the MS. See chapter 3.2.5.1 for the specific transmission timing of forward link dedicated physical channels, and the reception timing of reverse link dedicated physical channel. As soon as chip synchronisation and frame synchronisation using Frame Synchronization Word are established, hard wired transmission shall be started.

Based on the handover destination perch channel reception timing, the MS establishes chip synchronisation of forward link channel from handover destination BTS. As soon as chip synchronisation is established, maximal ratio combining with the forward link channel from handover source BTS shall be started.

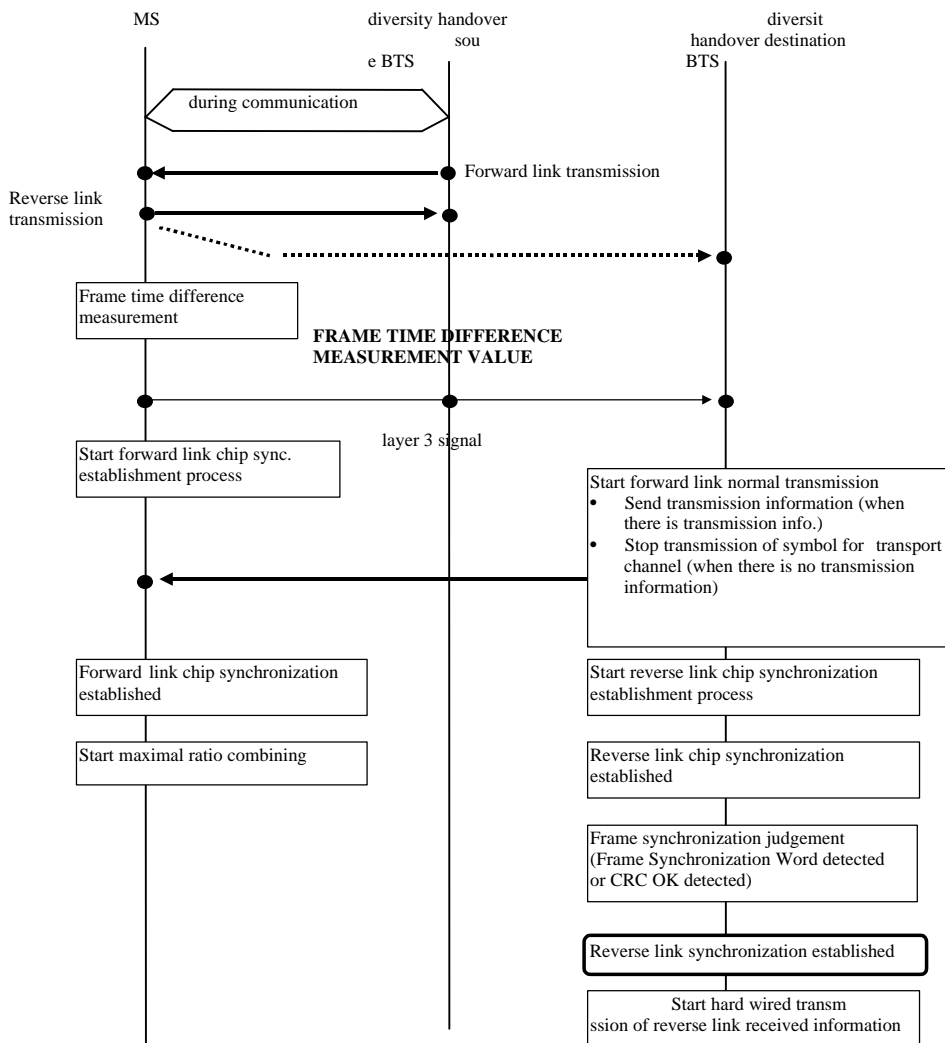

Figure 2 Synchronisation Establishment Flow Upon Intra/Inter-cell Diversity Handover

6.1.1.6 Inter System Handover

6.1.1.6.1 Handover 3G to 2G

The handover ~~between from UTRA and to GSM system~~ offering world-wide coverage already today has been one of the main design criteria taken into account in the UTRA frame timing definition. The GSM compatible multi-frame structure, ~~with the super frame being multiple of 120 ms~~, allows similar timing for inter-system measurements as in the GSM system itself. ~~The compatibility in timing is important, that when operating in UTRA mode, a multi mode UE is able to catch the desired information from the synchronization bursts in the synchronization frame on a GSM carrier with the aid of the frequency correction burst. This way the relative timing between a GSM and UTRA carriers is maintained similar to the timing between two asynchronous GSM carriers.~~

~~UTRA/FDD GSM dual mode UEs~~ The handover from UTRA/FDD to GSM can be implemented without simultaneous use of two receiver chains. Although the frame length is different from GSM frame length, the GSM traffic channel and UTRA FDD channels use similar ~~120 ms~~ multi-frame structure. ~~Similar timing can be naturally done with UTRA TDD mode as well.~~

A UE can do the measurements by using idle periods in the downlink transmission, where such idle periods are created by using the downlink slotted mode as defined in ~~reference [2] WG1 Specification~~. ~~In addition to downlink slotted frames for measurements, the UTRAN will provide uplink slotted frames to allow the UE to GSM cells on frequencies closed to the FDD uplink band.~~ The slotted mode is under the control of the UTRAN, and the UTRAN should communicate to the UE which frame is slotted.

Alternatively independent measurements not relying on the slotted mode, but using a dual receiver approach can be performed, where the GSM receiver branch can operate independently of the UTRA FDD receiver branch.

~~For smooth inter operation between the systems, information needs to be exchanged between the systems, in order to allow the UTRAN to notify the UE of the existing GSM frequencies in the area (see section 6.1.1.2.1.4). Further more integrated operation is needed for the actual handover where the current service is maintained, taking naturally into account the lower data rate capabilities in GSM when compared to UTRA maximum data rates reaching all the way to 2 Mbits/s.~~

~~UTRA/TDD GSM dual mode terminals~~ The Handover from UTRA/TDD to GSM can be implemented without simultaneous use of two receiver chains. Although the frame length is different from GSM frame length, the GSM traffic channel and UTRA TDD channels rely on similar ~~120 ms~~ multi-frame structure.

A UE can do the measurements either by efficiently using idle slots or by requesting free continuous periods in the downlink part obtained by reducing the spreading factor and compressing in time TS occupation in a form similar to the FDD slotted mode. The low-cost constraint excludes the dual receiver approach.

For smooth inter-operation, inter-system information exchanges are needed in order to allow The UTRAN to notify the UE of the existing GSM frequencies in the area and vice versa. Further more integrated operation is needed for the actual handover where the current service is maintained, taking naturally into account the lower data rate capabilities in GSM when compared to UMTS maximum data rates reaching all the way to 2 Mbits/s.

~~Basic requirements to correctly perform a handover in GSM are described in GSM 05.08 "Radio subsystem link~~

6.1.2 Radio Link Management

[Test to be deployed also based on sections 7.3.4, 7.3.5, 7.3.6 of S25.303]

6.1.2.1 Radio Link Addition (FDD soft-add)

The radio link addition procedure is defined in section 7.3.4 of TS 25.303.

Basically, the strategies that can be used in order to determine the need for radio link addition are based on the received measurements reports sent by the UE.

6.1.2.2 Radio Link Removal (FDD soft-drop)

The radio link removal procedure is defined in section 7.3.5 of TS 25.303.

Two main strategies can be used in order to determine the need for a radio link removal:

- received measurements reports sent by the UE
- load control

6.1.2.3 Combined Radio Link addition and removal

The combined radio link addition and removal procedure is defined in section 7.3.6 of TS 25.303.

Two main strategies can be used in order to determine the need for a combined radio link addition and removal:

- received measurements reports sent by the UE
- load control

7 Admission Control

7.1 Overall strategies

Principle 1: Admission Control is performed according to the type of required QoS.

“Type of service” is to be understood as an implementation specific category derived from standardized QoS parameters.

The following table illustrates the concept :

Service	Domain	Transport Channel	Type of service	CAC performed
Voice	CS	DCH	Premium*	YES
	IP	DCH	Premium*	YES
Web	IP	DSCH	Assured Service**	YES
	IP	DSCH	Best Effort***	NO

* *Premium service:* Low delay, high priority.

* *Assured Service:* A minimum rate below the mean rate is guaranteed, service may use more bandwidth if available, medium priority.

* *Best Effort:* No guaranteed QoS, low priority.

Other mapping are possible like for instance:

PSTN domain: Premium service, IP domain: Best Effort.

Assumption: Admission Control is performed by CRNC under request from SRNC.

[Editor's note, other criteria/principles are FFS]

7.2 Scenarios

7.2.1 CAC performed in SRNS

Figure 3 is to be taken as an example. It describes the general scheme that involves Admission Control.

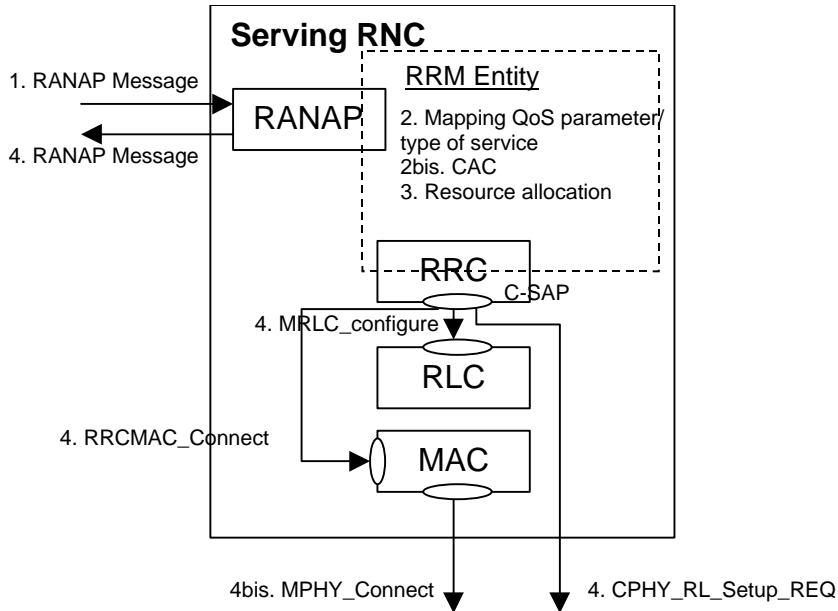

Figure 3: This model shows how standardized RANAP and RRC layers are involved in the CAC process. The dashed box represents a proprietary entity.

1. CN requests SRNC for establishing a RAB indicating QoS parameters.
2. According to QoS parameters the requested service is assigned a type of service. CAC is performed according to the type of service.
3. Resources are allocated according to the result of CAC.
4. Acknowledgement is sent back to CN according to the result of CAC. Sub_layers are configured accordingly.

Steps 2 to 4 may also be triggered by SRNC for reconfiguration purpose within the SRNC (handovers intra-RNC, channels reconfigurations, location updates).

7.2.2 CAC performed in DRNC

As CAC is always performed in CRNC it occurs in DRNC when Iur is to be used (soft handover, Cell/URA Update). [Editor's note please clarify the content of this sentence]

7.2.2.1 Case of DCH

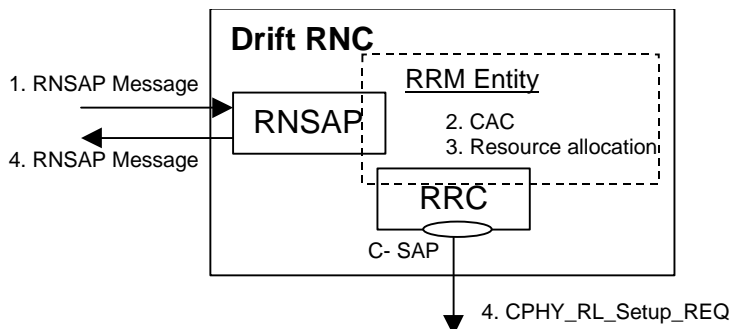

Figure 4: This model shows how standardized RNSAP and RRC layers are involved in the CAC process. The dashed box represents a proprietary entity.

1. SRNC requests DRNC for establishing a Radio Link, indicating DCH characteristics. These implicitly contains all QoS requirements and are enough as inputs to the CAC algorithm.
2. CAC is performed according to DCH characteristics.
3. Resources are allocated according to the result of CAC.
4. Acknowledgement is sent back to CN according to the result of CAC.

7.2.2.2 Case of Common Transport Channels

When transmitting packets on Common Transport Channels a UE may camp on a new cell managed by a new RNC. SRNC is notified by UE through RRC messages that connection will be set up through a new DRNC. Subsequently SRNC initiates connection through new DRNC.

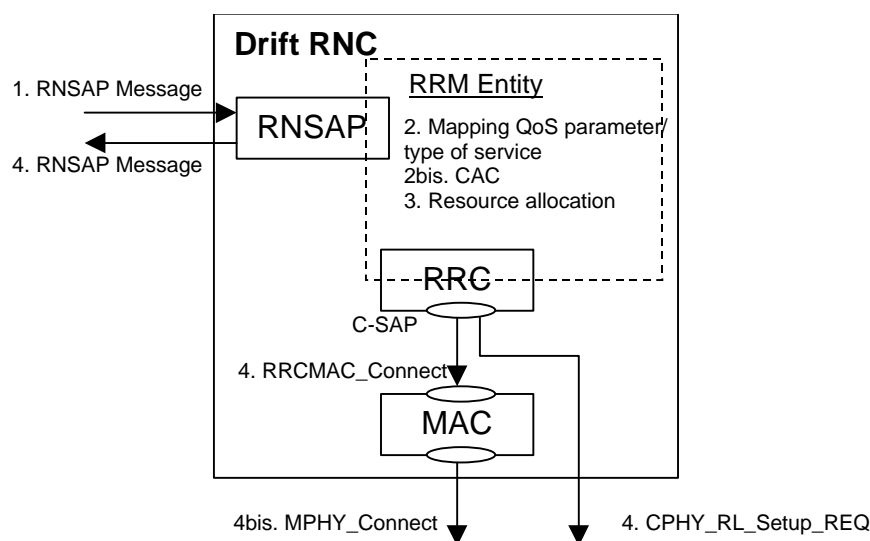

Figure 5: This model shows how standardized RNSAP and RRC layers are involved in the CAC process. The dashed box represents a proprietary entity.

1. SRNC requests DRNC for establishing a Radio Link. A RNSAP message contains the QoS parameters and the type of Common Transport Channel to be used.
2. According to QoS parameters the requested service is assigned a type of service. CAC is performed according to the type of service and to the type of Common Transport Channel requested by SRNC.
3. Resources are allocated according to the result of CAC.
4. Acknowledgement is sent back to CN according to the result of CAC. L1 and MAC are configured accordingly by RRC layer.

The RNSAP procedure is to be handled if a certain QoS is required. It may be avoided if the service just needs Best Effort. The decision to trigger the RNSAP procedure is to be taken by SRNC.

8 Radio Access Bearer Control

8.1 Radio Access Bearer Control – Overview of Procedures

[Test to be deployed also based on section 6.1 of S25.303]

8.2 Usage of RAB control procedures

Radio access bearer control procedures are used to control the UE and system resources. This section explains how the system works with respect to these procedures and how e.g. traffic volume measurements could trigger these procedures.

First a Radio access bearer setup is shown, where pre-configuration of transport channels are exemplified. Further, the procedures Physical channel reconfiguration and Transport channel reconfiguration are shown in several examples. It is also explained how these last two procedures are used in the system for resource control of services with variable bitrate, i.e. transport channel type switching. Finally, usage of Radio access bearer reconfiguration is shown in an example where the MAC multiplexing is changed.

8.2.1 Examples of Radio Access Bearer Setup

In order to set up a new Radio access bearer a RRC connection must have been established, and some NAS negotiation has been performed. The Radio access bearer setup message comes from UTRAN and depending on the requirement of the service a common or a dedicated transport channel could be used. In the example below the UE is using a common transport channel for the RRC connection and stays on the common transport channel after the RAB setup.

However, transport channel parameters such as transport formats and transport format combinations are configured not only for the used common transport channel, but also for dedicated transport channel for future use.

All physical parameters are the same before and after the RAB setup in this example.

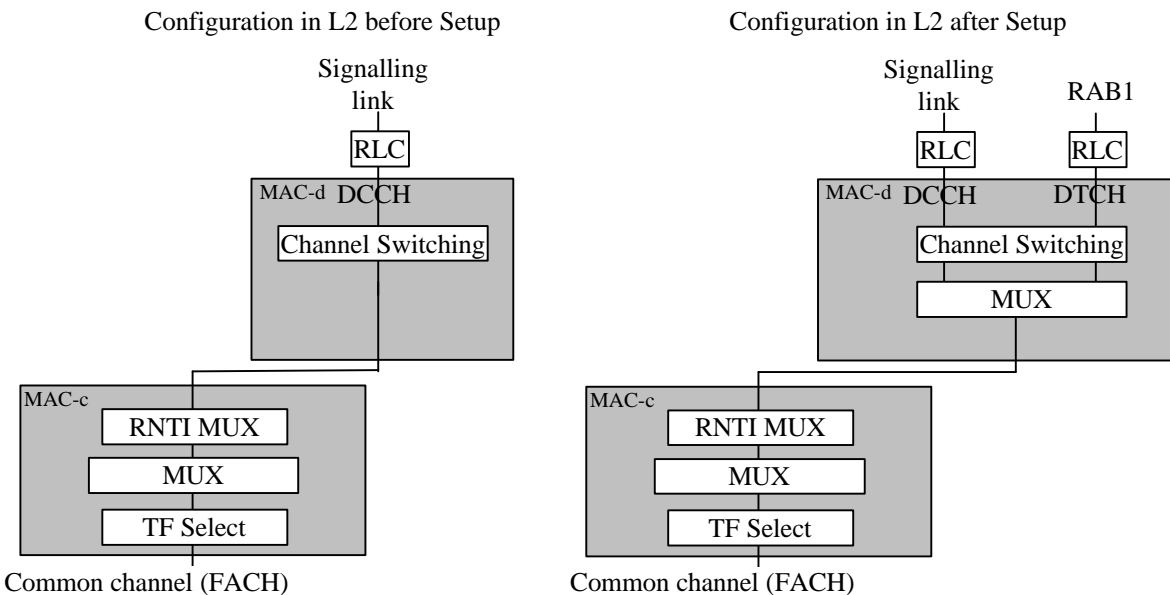

Figure 6 Configuration of L2 in the UTRAN DL before and after the RAB setup.

Detailed examples of messages exchange and parameters used is reported in Appendix B, Section. 143.1.

8.2.2 Examples of Physical Channel Reconfiguration

This RRC procedure is used to reconfigure the Physical channel and can by that also trigger Transport channel type switching.

Below several examples of Physical Channel reconfigurations are shown, triggered by different amount of UL or DL data.

8.2.2.1 Increased UL data, with switch from RACH/FACH to DCH/DCH

A UE that is in the RACH/FACH substate can transmit a small amount of user data using the common transport channels. For larger amounts it is more appropriate to use a dedicated transport channel. Since each UE doesn't know

the total load situation in the system UTRAN decides if a UE should use common transport channels or a dedicated transport channel.

The monitoring of UL capacity need is handled by a UTRAN configured measurement in the UE. When the amount of data in the RLC buffer to be transmitted in the UL increases over a certain threshold the UE sends a measurement report to UTRAN. This threshold to trigger the report is normally given in System Information, but UTRAN can also control the threshold in a UE dedicated Measurement Control message.

Since, UTRAN has the current status of the total UL need it can decide which UEs that should be switched to a dedicated transport channel. If UTRAN has pre-configured the transport formats and transport format combinations to be used on the dedicated transport channel for the UE, a Physical channel reconfiguration procedure could be used to assign dedicated physical resources.

The spreading factor for the physical channels assigned then give, which transport format combinations that are allowed to use.

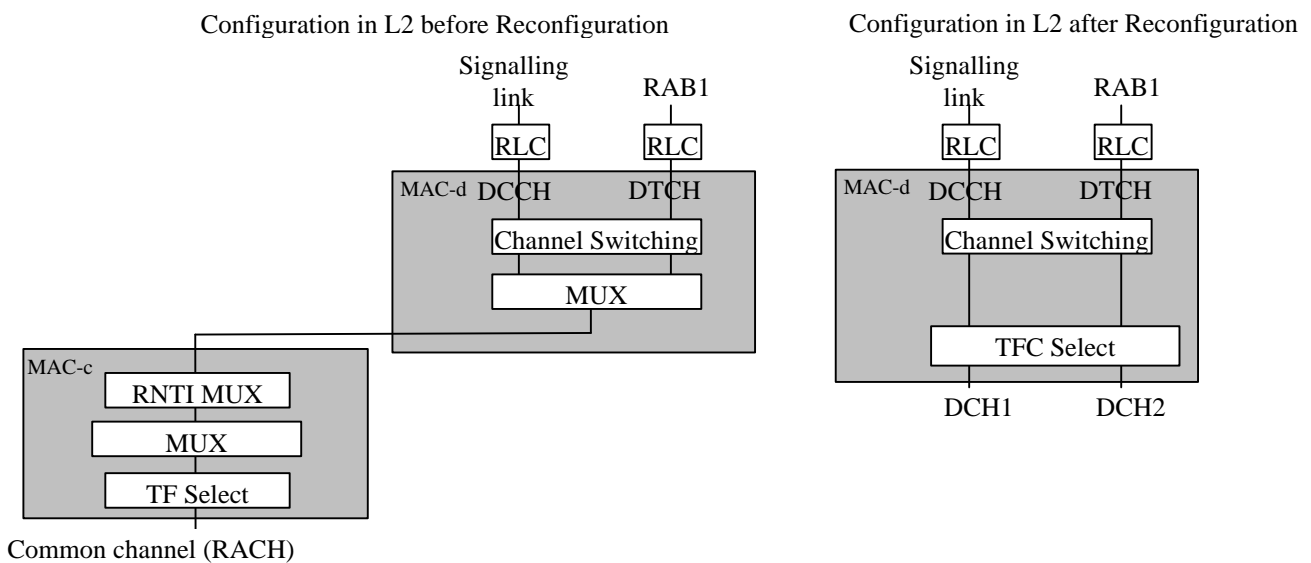

Figure 7 Configuration in the UTRAN UL before and after the Physical channel reconfiguration.

Detailed examples of messages exchange and parameters used is reported in Appendix B, Section. 143.2.1.

8.2.2.2 Increased DL data, no Transport channel type switching

If the RLC buffer increases above a certain threshold [*Note: This is only one of many possible implementations of the network*] in the network the UTRAN can do a physical channel reconfiguration. Here the UE uses a dedicated transport channel, and this procedure is used to decrease the spreading factor of the physical dedicated channel. This way this variable bitrate service increases the throughput on the downlink.

A variable bitrate service that has large traffic variations should have transport formats and transport format combinations defined for lower spreading factors than currently used on the physical channel. Then after the physical channel reconfiguration that lowers the spreading factors these transport formats and transport format combinations could be used to increase the throughput for this user.

However, if the transport formats and transport format combinations have not been previously defined to support a lower spreading factor, a Transport channel reconfiguration must be used instead in order to get any increased throughput.

Only downlink physical parameters are changed here since the uplink in this scenario doesn't need to increase its capacity.

Detailed examples of messages exchange and parameters used is reported in Appendix B, Section. 143.2.2.

8.2.2.3 Decrease DL data, no Transport channel type switching

Since downlink channelization codes are a scarce resource a UE with a too high, allocated gross bit rate (low spreading factor) must be reconfigured and use a more appropriate channelization code (with higher spreading factor). This could be triggered by a threshold for the RLC buffer content and some inactivity timer, i.e. that the buffer content stays a certain time below this threshold. *[Note: This is only one of many possible implementations of the network].*

After the physical channel has been reconfigured, some of the transport formats and transport format combinations that require a low SF can not be used. However, these are stored and could be used if the physical channel is reconfigured later to use a lower spreading factor.

Detailed examples of messages exchange and parameters used is reported in Appendix B, Section. 143.2.3.

8.2.2.4 Decreased UL data, with switch from DCH/DCH to RACH/FACH

In the network the UE traffic can be evaluated and the network can observe which transport format combinations that are used in the UL. The network could also simply look at how much data the UE transmits or use measurement reports *[Note: Which way for the network to trigger this is a matter of implementation].*

If the UE is transmitting a low amount of data in the uplink and there is little traffic in the downlink, this could trigger a switch from a dedicated transport channel to a common transport channel. Depending on if the already defined RACH/FACH configuration is possible/preferred in the cell that the UE will be in after the switch, a Transport channel reconfiguration or a Physical channel reconfiguration procedure is used.

In the example below the UE has stayed in cells with a similar RACH and FACH configuration when using a dedicated transport channel. Therefore, the Physical channel reconfiguration procedure can be used. In 8.2.3.2 this is not the case and a Transport channel reconfiguration is used instead.

After the UE has performed the transport channel type switch to the RACH/FACH substate, all transport channel parameters such as transport formats for the dedicated transport channel are stored. The same configuration of the dedicated transport channels could then be reused if the UE switches back to the DCH/DCH substate.

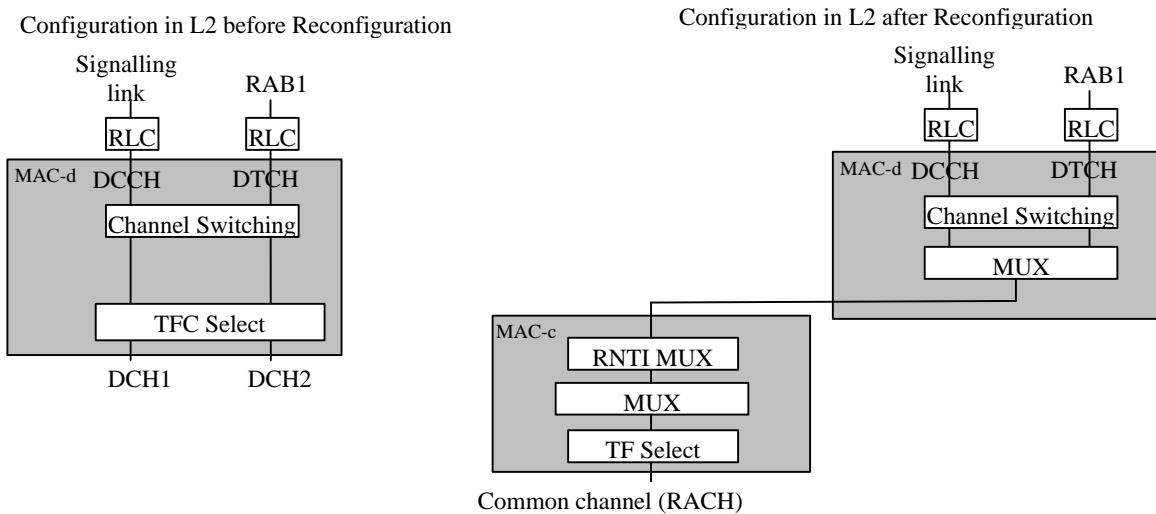

Figure 8 Configuration in the UTRAN UL before and after the Physical channel reconfiguration.

Detailed examples of messages exchange and parameters used is reported in Appendix B, Section. 143.2.4.

8.2.3 Examples of Transport Channel Reconfiguration

This RRC procedure is used to reconfigure the transport channel and the physical channels, and can by that also trigger Transport channel type switching.

Below, several examples of Transport channel reconfiguration are shown, triggered by different amount of UL or DL data.

8.2.3.1 Increased UL data, with no transport channel type switching

When a UE RLC buffer content increases above a certain threshold, a measurement report is sent to UTRAN. Depending on the overall load situation in the network the UTRAN could decide to increase the uplink capacity for a UE. Since every UE has its “own” code tree, there is no shortage of UL codes with a low spreading factor, and all UEs can have a low spreading factor code allocated.

Therefore, instead of channelization code assignment as used in the DL, load control in the UL is handled by the allowed transport formats and transport format combinations for each UE. To increase the throughput for a UE in the uplink, UTRAN could send a Transport channel reconfiguration or a TFC Control message.

Here a Transport channel reconfiguration is used. Although, the TFC Control procedure is believed to require less signalling it can only restrict or remove restrictions of the assigned transport format combinations and that may not always be enough. If a reconfiguration of the actual transport formats or transport format combinations is required, the Transport channel reconfiguration procedure must be used instead.

In the example below, the UE is allowed to send more data in the UL when on dedicated transport channel, although the common transport channel configuration is still the same. To make use of the new transport format combinations the physical channel must also be reconfigured to allow a lower spreading factor.

Detailed examples of messages exchange and parameters used is reported in Appendix B, Section. 14.3.3.1.

8.2.3.2 Decreased DL data, with switch from DCH/DCH to RACH/FACH

In the network the downlink traffic to a UE can be evaluated and the network can observe which transport format combinations that are used [Note: This is only one of many possible implementations of the network].

If a low amount of data is sent to the UE in the downlink and there is little traffic in the uplink, this could trigger a switch from a dedicated transport channel to a common transport channel. Depending on if the already defined RACH/FACH configuration is possible/preferred in the cell that the UE will be connected to after the switch, a Transport channel reconfiguration or a Physical channel reconfiguration procedure is used. In this example the UE has moved to cells with a different FACH or RACH configuration when using a dedicated transport channel, so a Transport channel reconfiguration procedure must be used.

When the UE do the switch from a dedicated transport to a common transport channel the RACH and FACH transport channels are reconfigured with new transport formats if the old configuration is not supported in the new cell. What physical common channel to be used is pointed out in the physical channel parameters.

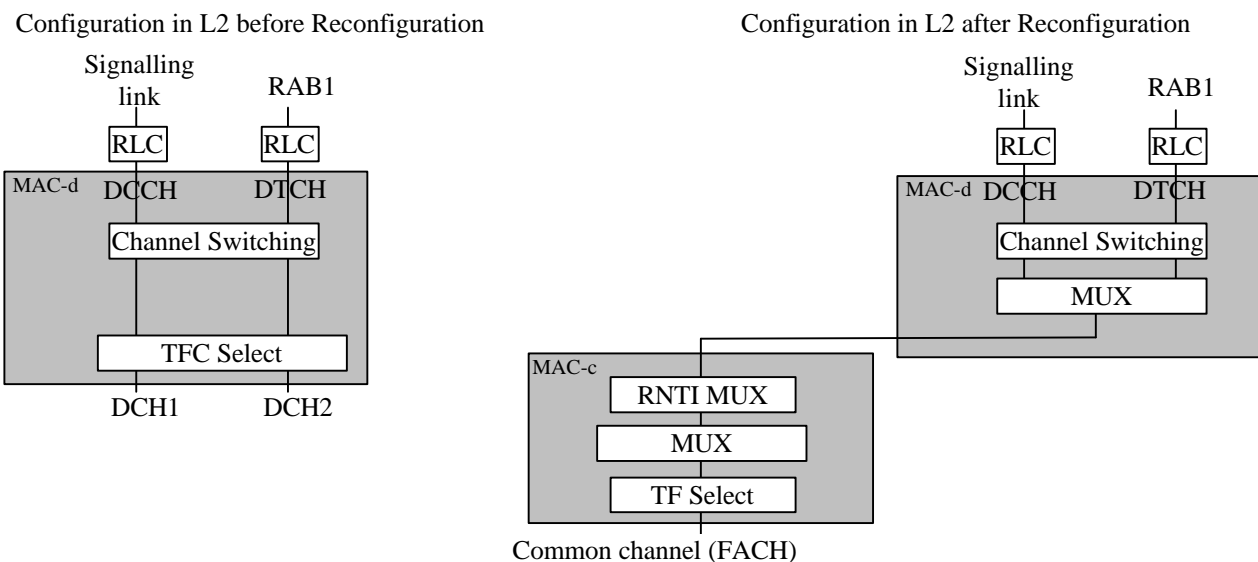

Figure 9 Configuration in the UTRAN DL before and after the Transport channel reconfiguration.

Detailed examples of messages exchange and parameters used is reported in Appendix B, Section. 14.3.3.2.

8.2.4 Examples of RAB and Signalling link Reconfiguration

A Radio access bearer reconfiguration is here used to change how the MUX in MAC of logical channels belonging to different RABs is configured.

The RAB Reconfiguration message includes parameters for the new multiplexing configuration in MAC, and a reconfiguration of the Transport channel that both RABs will use. The old obsolete transport channel is also removed (here DCH3 is removed). All other parameters associated with the RABs are unchanged.

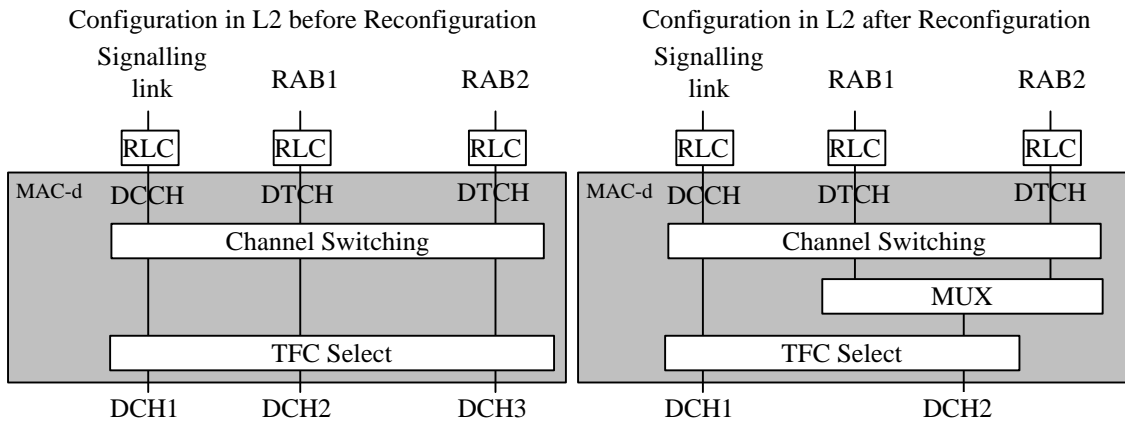

Figure 10 Configuration in the UTRAN DL before and after the RAB reconfiguration.

Detailed examples of messages exchange and parameters used is reported in Appendix B, Section. 143.4.

9 Dynamic Channel Allocation

9.1 DCA (FDD)

[Editor's note: this section acts as a place holder for possible dynamic resource allocation strategies for FDD mode, e.g. code management]

9.2 DCA (TDD)

9.2.1 Channel Allocation

<not covered in ARIB TDD>

For the UTRA-TDD mode a physical channel is characterised by a combination of its carrier frequency, time slot, and spreading code as explained in the chapter on the physical channel structure

Channel allocation covers both :

- resource allocation to cells (slow DCA)

resource allocation to bearer services (fast DCA)

9.2.1.1 Resource allocation to cells (slow DCA)

<not covered in ARIB TDD>

Channel allocation to cells follows the rules below:

- A reuse one cluster is used in the frequency domain. In terms of an interference-free DCA strategy a timeslot-to-cell assignment is performed, resulting in a time slot clustering. A reuse one cluster in frequency domain does not need

frequency planning. If there is more than one carrier available for a single operator also other frequency reuse patterns >1 are possible.

- Any specific time slot within the TDD frame is available either for uplink or downlink transmission . UL/DL resources allocation is thus able to adapt itself to time varying asymmetric traffic.
- In order to accommodate the traffic load in the various cells the assignment of the timeslots (both UL and DL) to the cells is dynamically (on a coarse time scale) rearranged (slow DCA) taking into account that strongly interfering cells use different timeslots. Thus resources allocated to adjacent cells may also overlap depending on the interference situation.
- Due to idle periods between successive received and transmitted bursts, UEs can provide the network with interference measurements in time slots different from the one currently used. The availability of such information enables the operator to implement the DCA algorithm suited to the network.
- For instance, the prioritized assignment of time slots based on interference measurements results in a clustering in the time domain and in parallel takes into account the demands on locally different traffic loads within the network.

9.2.1.2 Resource allocation to bearer services (fast DCA)

<not covered in ARIB TDD>

Fast channel allocation refers to the allocation of one or multiple physical channels to any bearer service Resource units (RUs) are acquired (and released) according to a cell-related preference list derived from the slow DCA scheme.

1. The following principles hold for fast channel allocation: The basic RU used for channel allocation is one code / timeslot / (frequency).
2. Multirate services are achieved by pooling of resource units. This can be made both in the code domain (pooling of multiple codes within one timeslot = **multicode** operation) and time domain (pooling of multiple timeslots within one frame = **multislot** operation). Additionally, any combination of both is possible. Simulation results reported in Appendix A, recommend that the DCA prefers code pooling , over time slot pooling, for UDD packet data; the use of code pooling in fact results in lower number of unsatisfied users.
3. Since the maximal number of codes per time slot in UL/DL depends on several physical circumstances like , channel characteristics, environments, etc. (see description of physical layer) and whether additional techniques to further enhance capacity are applied (for example smart antennas),. the DCA algorithm has to be independent of this number. Additionally, time-hopping can be used to average inter-cell interference in case of low-medium bit rate users.
 - 4. Channel allocation differentiates between RT and NRT bearer services: RT services: Channels remain allocated for the whole duration the bearer service is established . The allocated resources may change because of a channel reallocation procedure (e.g. VBR).
 - NRT services: Channels are allocated for the period of the transmission of a dedicated data packet only UDD channel allocation is performed using ‘best effort strategy’, i.e. resources available for NRT services are distributed to all admitted NRT services with pending transmission requests. The number of channels allocated for any NRT service is variable and depends at least on the number of current available resources and the number of NRT services attempting for packet transmission simultaneously. Additionally, prioritisation of admitted NRT services is possible.
5. Channel reallocation procedures (intra-cell handover) can be triggered for many reasons:
 - To cope with varying interference conditions.
 - In case of high rate RT services (i.e. services requiring multiple resource units) a ‘channel reshuffling procedure’ is required to prevent a fragmentation of the allocated codes over to many timeslots. This is achieved by freeing the least loaded timeslots (timeslots with minimum used codes) by performing a channel reallocation procedure.
 - When using smart antennas, channel reallocation is useful to keep spatially separated the different users in the same timeslot.

9.2.2 Measurements Reports from UE to the UTRAN

While in active mode the DCA needs measurements for the reshuffling procedure (intra-cell handover). The specification of the measurements to be performed is contained in Section 7.4 in [10]. In this section the relevant measurement reports are presented:

- Pathloss of a sub-set of cells (pathloss is quantized in N_{PL} [e.g. 128] intervals ; [max. number of cells is 30].
- Inter-cell interference measurements of all DL time slots requested by the UTRAN (interference is quantized in N_{ICI} [e.g. 32] intervals, due to asymmetry up to 14 time slots are possible)
- BER of serving link (quantized in N_{BER} [e.g. 16] intervals)
- Transmission power of the UE on serving link (separated in N_{TX} [e.g. 64] intervals)
- DTX flag link
- ffs

Further measurements and reports can be requested by the UTRAN.

The RLC informs the DCA about transmission errors. The interaction between DCA and RLC depends on the RLC operation mode. Details are for further study.

10 Power Management

10.1 Variable Rate Packet Transmission

10.1.1 Downlink Power Management

When the connection for packet services is established, the RRC considers the down-link traffic conditions, then assigns the TFCS to MAC and allowable transmission power to L1. The allowable transmission power is determined according to the service requirements and the traffic conditions, and is updated for each user when the traffic conditions change.

During a call, the physical layer averages the transmission power for that UE over one or several frames. If the averaged transmission power for the UE becomes higher than the allowable transmission power, that is, the channel conditions are bad, L1 indicates with the primitive MPHY-STATUS to the MAC that the “Allowable transmission power has been reached”. The MAC in response reduces the data rate within TFCS, and the power control procedure then reduces the total transmission power for that UE and excess interference to other UEs is avoided.

When channel conditions improve and the averaged transmission power falls [x] dB below than the allowable transmission power the physical layer indicates with the primitive MPHY-STATUS to the MAC that the “Average transmission power is

below allowable transmission power by xdB” (the values for [x] are chosen to match the power requirements of different increments for the transport channels within the TFCS). The MAC in response increases the data rate by increasing the number of transport blocks delivered to L1 and the physical layer increases the total transmission power to the UE by the predefined amount. This allows data that was buffered during bad channel conditions to be delivered to the UE.

10.1.2 Uplink Power Management

When the connection for packet services is established, the RRC assigns the TFCS to MAC and the allowable transmission power to L1. The allowable transmission power corresponds to the UE capability class. During a call, the physical layer averages the transmission power over one or several frames. If the averaged transmission power becomes higher than the allowable transmission power, L1 indicates with the primitive MPHY-STATUS to the MAC that the “Allowable transmission power has been reached”. The MAC in response reduces the data rate within TFCS, and the power control procedure then reduces the total transmission power.

When channel conditions improve and the averaged transmission power falls [x] dB below than the allowable transmission power the physical layer indicates with the primitive MPHY-STATUS to the MAC that the “Average transmission power is below allowable transmission power by xdB” (the values for [x] are chosen to match the power requirements of different increments in the number of transport channels within the TFCS). The MAC in response

increases the data rate by increasing the number of transport blocks delivered to L1 and the physical layer increases the total transmission power by the predefined amount. This allows data that was buffered during bad channel conditions to be transmitted to Node B.

10.2 Site Selection Diversity Power Control (SSDT)

Site Selection Diversity Transmit Power Control (SSDT) is a form of power control for the downlink that can be applied while a UE is in soft handover (SHO). This section explains how SSDT works, and provides some examples when SSDT should be used. Simulations have been performed comparing SHO with SSDT to normal SHO: results are presented in Appendix D.

In SHO, a UE has DL connections to more than one cell. Thus, one UE contributes to the DL interference in several cells. SSDT is a power control method that reduces the DL interference generated while the UE is in SHO. The principle of SSDT is that the best cell of the active set is dynamically chosen as the only transmitting site, and the other cells involved turn down off their DPDCHs. The DPCCH is transmitted as normally (see figure below).

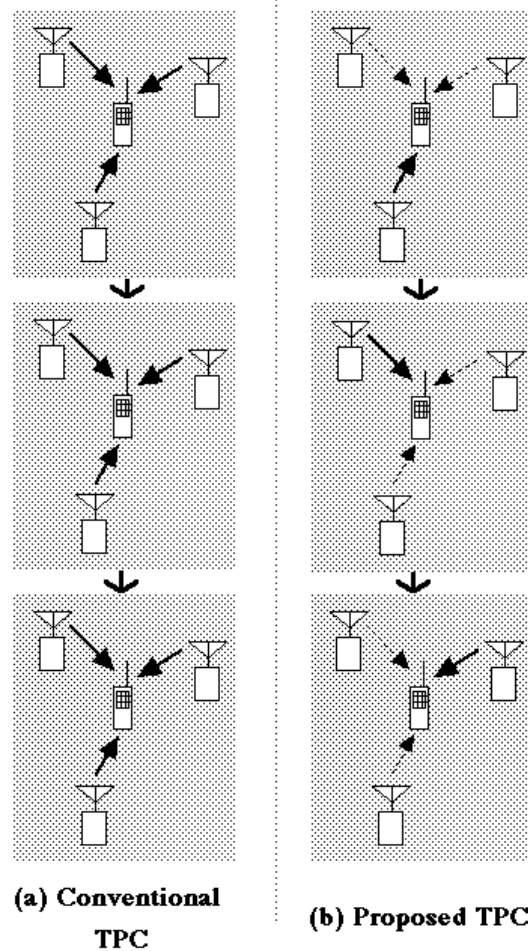

Principle of SSDT in comparison to conventional SHO

Each cell is given a temporary identification number. The UE measures the pilot power of the PCCPCHs, and chooses the best one as its 'primary' cell. The temporary id of this primary cell (the 'primary id') is transmitted on the UL DPCCH to all Node Bs of the active set. A cell that has been selected as primary station transmits its dedicated channels with the power necessary to reach the desired SIR target, whereas all other cells switch off their downlink DPDCH transmission. The 'primary id' is updated by the UE at a frequency of 5, 10 or 20ms. The frequency depends on the SSDT mode and is set by the UTRAN.

In order for the UE to continuously perform measurements and to maintain synchronisation, the 'secondary' cells continue to transmit pilot information on the DPCCH.

The prerequisite for using SSdT during an RRC connection or during a part of an RRC connection is that all Node B involved support SSdT. SSdT is controlled by L3 procedures. The control involves assignment of temporary ids, setting an SSdT mode and switching SSdT on or off. The control information itself (temporary ids) terminates in the L1 of Node B and UE respectively.

11 Radio Link Surveillance

11.1 Mode Control strategies for tx diversity

11.1.1 TX diversity modes

Tx diversity modes can be classified into two categories:

- Open loop modes
- Closed loop modes

In open loop mode no feedback information from the UE to the node B is transmitted in order to control how the signal is transmitted from the diversity antennas. This is in contrast to closed loop operation where UE sends feedback information to the Node B in order to optimize the transmission from the diversity antennas.

For a detailed description of Tx diversity techniques in both FDD and TDD mode, refer to [L1 Spec].

11.1.2 Mode Control Strategies

11.1.2.1 DPCH

What mode will be used on DPCH and when is controlled by Node B. Important criteria for the mode control are the radio channel conditions. This is because depending on the radio channel different modes will provide the best performance.

Regarding the downlink performance there are two important factors which should be considered when doing mode control:

- Maximum doppler frequency (i.e., speed of the UE)
- Number of multipath components.

Basically the UE could measure both of these and report back to Node B. As it happens both of these can be measured by Node B as well. Therefore, there is no need to signal this information from UE to Node B.

It would also be very important to have the possibility to indicate if there is a default Tx diversity mode used on the dedicated channels. We could further define a default Tx diversity mode separately for the case of non-SHO and SHO. This kind of information could be broadcasted on BCCH or could be defined in call set up. The benefit of it could be reduced signalling e.g. in SHO but the drawback is the increased overhead of BCCH or additional signalling in call set up. Note that even if no default mode exist the use of Tx diversity on dedicated channels can be told to UE in call set-up phase.

11.1.2.2 Common channels

Only open loop can be used for PCCPCH, SCCPCH, and AICH. For common channels the most straightforward way of informing the UE about the use of Tx diversity on them is to broadcast the information on BCCH. How many bits per BCCH frame is needed depends on how much flexibility will be given to operators in use of Tx diversity. Two extreme cases are:

- Most limited flexibility: one bit every BCCH frame is used to indicate if Tx diversity is being used on PCCPCH, SCCPCH and AICH
- Maximum flexibility: use of Tx diversity on different broadcast channels can be controlled independently. Obvious way of informing UE about this is to transmit 3 bits of information in each BCCH frame. Note that the impact of the use of 3 bits on the overall BCCH capacity has to be further considered.

12 Codec mode control

12.1 AMR mode control

The AMR speech codec consists of the multi-rate speech codec with eight source rates from 4.75 kbit/s to 12.2 kbit/s [11]. The change between the AMR specified rates is proposed to occur in the WCDMA in downlink, when traffic on the air interface exceeds the acceptable load, or when the connection based FER value indicates the bad quality of the connection. In uplink the corresponding change can be made when there is need to extend the uplink coverage area for speech by using several AMR modes or when the measured load on the air interface is reported to exceed the acceptable level.

In principle the speech coder is capable of switching its bit rate every 20 ms speech frame upon command. [11] However in practice the AMR mode adaptation is needed less frequently.

In WCDMA the network architecture has been defined to consist of two different network domains; UTRAN and Core Network (CN). Due to this definition and decisions about the location of the Transcoder, the AMR related functions are forced to divide between the previously mentioned network domains.

The location of the Transcoder in WCDMA was defined to be in the core network domain, and logically outside the Access Stratum. Thus also the location of the AMR speech codec is into the Core Network as well.

From the data transfer point of view the defined location of the encoder in the NW side means that at least all AMR coded data is going to be transmitted not only via Iub and air interface but also via Iu – interface. (see Figure 12)

The functionality of the codec mode control on the contrary can not locate in the Transcoder, because this control entity needs information from the air interface to make decision about the valid AMR modes for the AMR related connections. Thus the only domain, which can provide this kind of information from the air interface to AMR codec mode control entity, is UTRAN. In GSM the control of the codec mode is provided by the BTS, but in WCDMA this solution is not applicable due to soft handover procedure defined for the dedicated traffic channels. Thus the AMR mode control function should be a part of the RNC functionality. In RNC the most natural place to perform the control of the AMR mode is RRM, because RRM is already responsible for reserving and controlling resources from the air interface. Thus all information, which is needed for the AMR adaptation, can be found from the RRM, which is a part of the current L3 functionality. (see Figure 12)

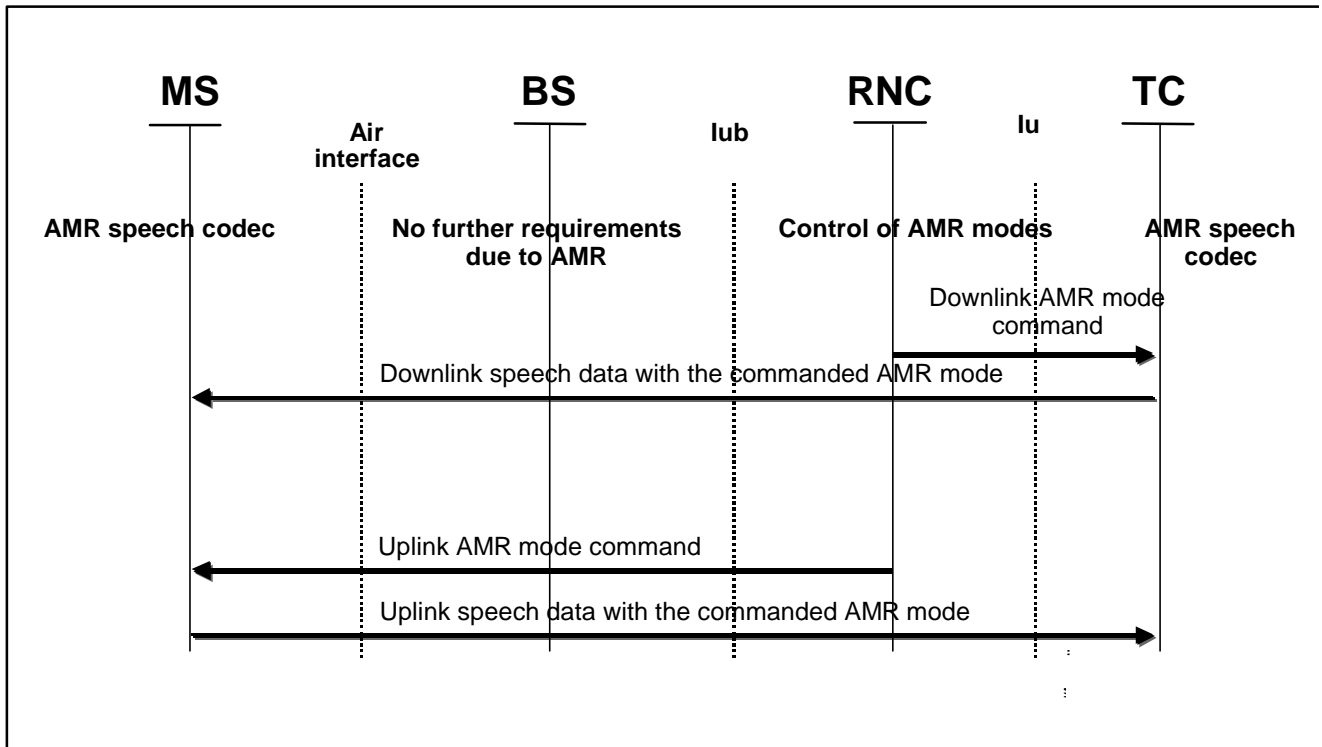

Figure 12

In the WCDMA the AMR mode adaptation is carried out with the aid of AMR mode control function, which is responsible for detecting the need of the AMR mode adaptation and to initiate required procedures to change the current AMR mode to the newly selected AMR mode. The AMR mode change request can be made with the aid of the AMR mode command, which is sent from the RNC either to the Transcoder for downlink data transfer or to the UE for uplink data transfer. In principle the supported AMR mode adaptation can be asymmetric, which implies the possibility to use different AMR modes in uplink and downlink during active speech call.

Therefore, the role of the RRM during the AMR coded speech call will be basically the role of the supervisor of the connection.

The AMR mode command is used to change the current AMR mode to the new one, which suits better to the conditions on the air interface. The command is sent from the UTRAN to the appropriate AMR codec, which locates either in the transcoder or in the UE. In which encoder the command is sent depends on direction of the data transmission. If the AMR mode - in question - is intended to be used in downlink the command is sent to the encoder inside the transcoder via Iu -interface, whereas AMR code needed on uplink is sent to the UE through air interface.

The initialization of AMR mode command will base on load information, which has been received from the air interface. The following table shows the required information during the AMR mode adaptation in WCDMA:

Information used in AMR control	Load
Downlink information	BS reports total BS transmission power
Uplink information	BS measurers total interference level

When RRM indicates the need for the AMR mode adaptation, RRC may generate the requested AMR mode command and send it to the encoder, or RRC may request MAC -d to perform the same functions. Which layer is used depend on whether the AMR mode command is intended to use on uplink or on downlink, and whether inband or outband signaling is used for transferring the command from the UTRAN to the encoder.

For the downlink, the AMR mode command from RNC to TC is realised as inband.

Transport format for the transport channel carrying the different classes of AMR source codec provide an unambiguous mapping of the codec mode that is used.

13 Appendix A - (Simulations on Fast Dynamic Channel Allocation)

13.1 Simulation environment

The presented simulations are performed in the following environments and services according to the requirements in the following documents:

- ETSI TR 101 112, Selection procedures for the choice of radio transmission technologies of the Universal Mobile Telecommunications System UMTS (UMTS 30.03), version 3.2.0, April 1998.
- Seppo Hämäläinen, Peter Slanina, Magnus Hartman, Antti Lappeteläinen, Harri Holma, Oscar Salonaho, A Novel Interface Between Link and System Level Simulations, Acts Mobile Communications Summit '97, pp. 599-604, Aalborg/Denmark, Oct 7-10, 1997.

Absolute capacities [kbit/s/MHz/cell] were published in:

- ETSI Tdoc SMG2 306/98, UTRA TDD Link Level and System Level Simulation Results for ITU Submission, Source: Siemens, Helsinki, Sep 8-11, 1998.

1. Macro (Vehicular) environment for the UDD 144 kbit/s service.
2. Micro (Outdoor-to-Indoor Pedestrian) environment for the UDD 384 kbit/s service.

13.2 Results

The relative load of the cell is used for the abscissa (horizontal axis) in all of the plots. Here, a relative load of 100% refers to the maximum cell load obtainable with code-pooling under the ETSI unsatisfied user criterion (in accordance with ETSI TR 101 112). Vertically, the percentage of unsatisfied users is shown.

13.2.1 Macro UDD 144

In the Macro environment the UDD 144 service is simulated with Hybrid ARQ Type II-III using an adaptive code-rate

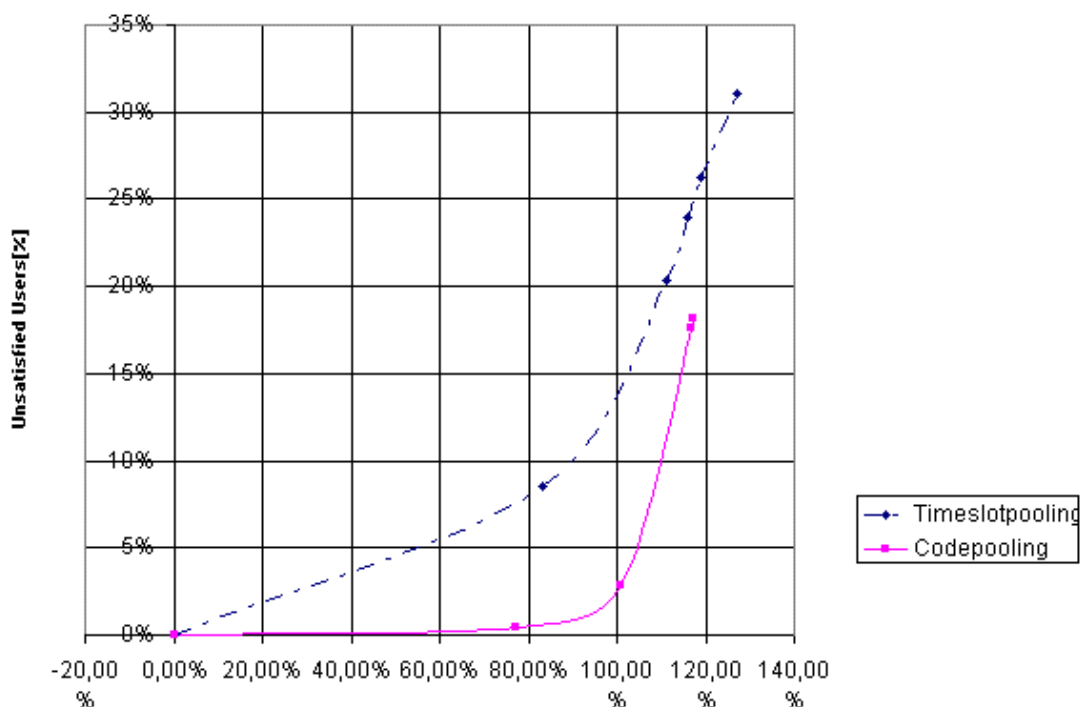

between 1 and 1/2

13.2.2 Micro UDD 384

In the Micro environment the UDD 384 service is simulated with Hybrid ARQ I using code-rates 1 and 2/3.

13.2.2.1 Code rate 1

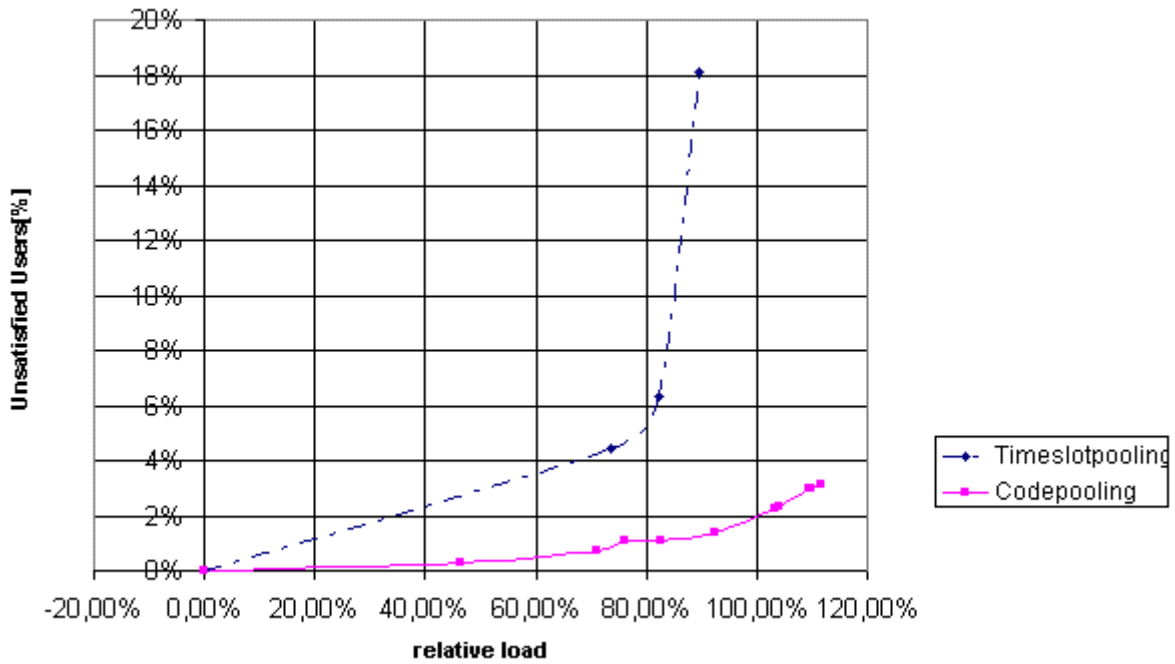

13.2.2 Code rate 2/3

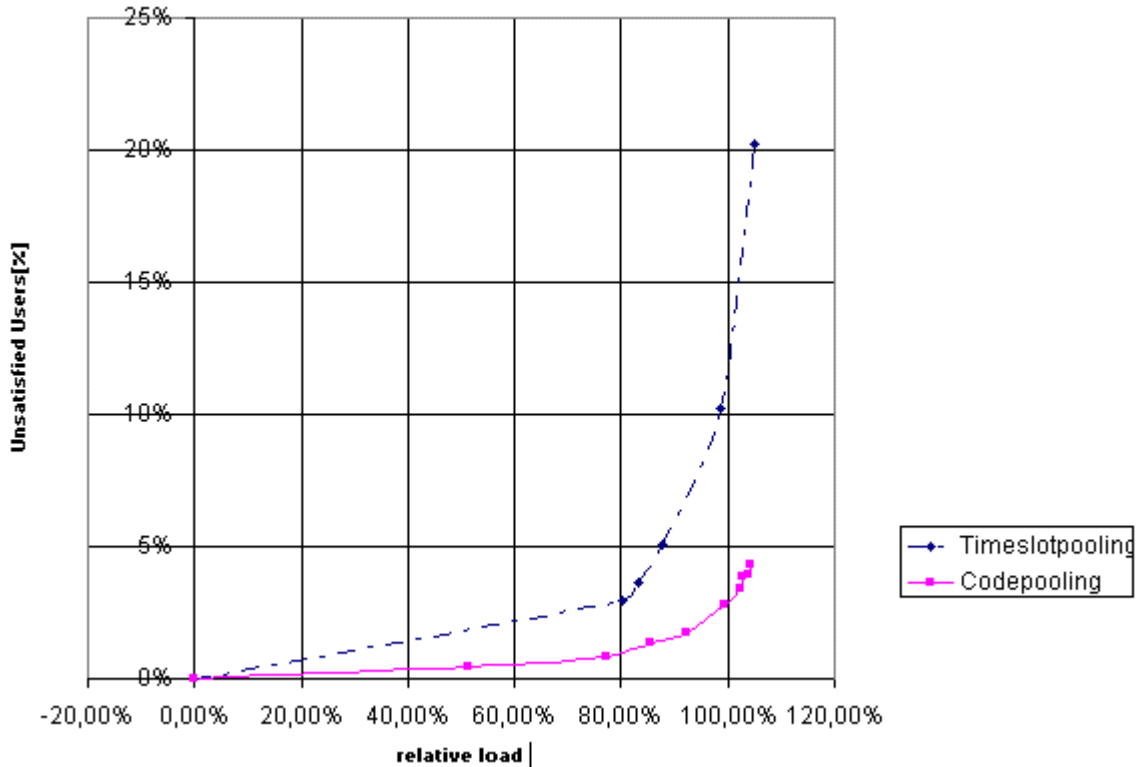

13.3 Conclusions

With both Hybrid ARQ I and Hybrid ARQ II code pooling performs better than time slot pooling. This is explained as follows: Code-pooling performs better in conjunction with the initial transmission of Hybrid ARQ Type II-III. Timeslot pooling suffers from a high probability of low CIR in at least one of the used timeslots of the PDU. This leads to a high initial transmission failure probability because the initial transmission is sent almost uncoded. When code-pooling is applied, the whole PDU depends on the same interference level on all codes: the probabilities of low CIR on each spreading-code within the same timeslot are strongly coupled.

- The probability of PDU transmission failure for code-pooling is approximately the same as the probability of low CIR in a single timeslot.
- The probability of PDU transmission failure for timeslot-pooling is approximately the same as the probability of low CIR in at least one of the used timeslots.

This advantage of code-pooling results in lower numbers of unsatisfied users. These results clearly recommend that the DCA prefers code pooling over timeslot pooling for UDD packet data in TDD mode.

14 Appendix B (Radio Access Bearer Control – Overview of Procedures: message exchange and parameters used)

14.1 Examples of Radio Access Bearer Setup

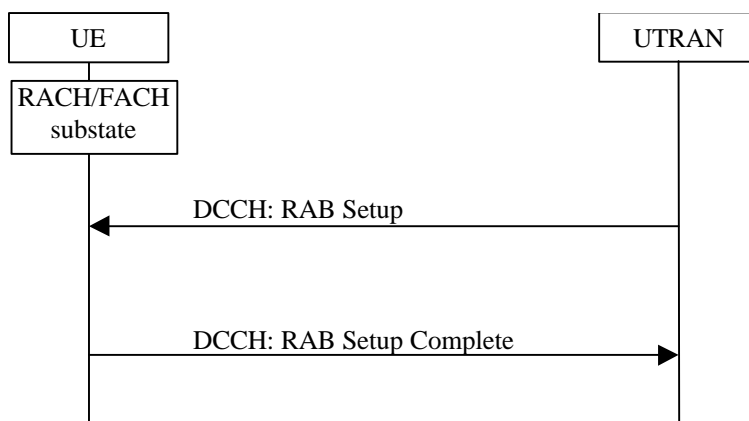

Figure 11 Radio access bearer setup on common transport channel.

14.1.1 RRC Parameters in RAB Setup

This message includes **RAB identity** for the new RAB and **RLC info**. It also includes **two different multiplexing configurations** giving the transport channel this RAB could be mapped onto. One configuration to be used on a common transport channel and one for a dedicated transport channel.

For the common transport channel this message includes a new **Transport format set for FACH**, and a **Transport format set for RACH**.

For the dedicated transport channel (pre-configured, not yet used) this message includes the **transport formats for DCH1 and DCH2**, and also the **transport format combinations** used in e.g. 13.2.1, after the switch.

14.1.2 RRC Parameters in RAB Setup Complete

This message includes the identity of the new RAB, **RAB1**.

14.2 Examples of Physical Channel Reconfiguration

This RRC procedure is used to reconfigure the Physical channel and can by that also trigger Transport channel type switching.

Below several examples of Physical Channel reconfigurations are shown, triggered by different amount of UL or DL data.

14.2.1 Increased UL data, with switch from RACH/FACH to DCH/DCH

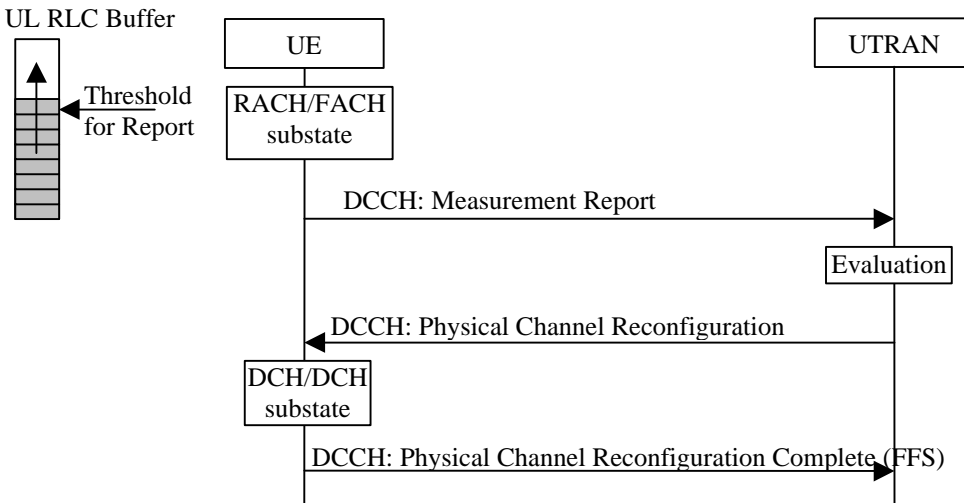

Figure 12 Physical channel reconfiguration triggered by increased UL data and with a switch from RACH/FACH to DCH/DCH.

14.2.1.1 RRC Parameters in Measurement Report

This message includes a **Measurement Identity number** so that UTRAN can associate this report with a Measurement control message. It also includes the **Measurement result** stating what triggered the report and optionally the RLC buffer payload.

14.2.1.2 RRC Parameters in Physical Channel Reconfiguration

This message includes **DL channelization codes** and **DL scrambling code** for the DPCH. It also includes **UL channelization codes** and **scrambling code** for the DPCH.

14.2.1.3 RRC Parameters in Physical Channel Reconfiguration Complete

No identified parameters

14.2.2 Increased DL data, no Transport channel type switching

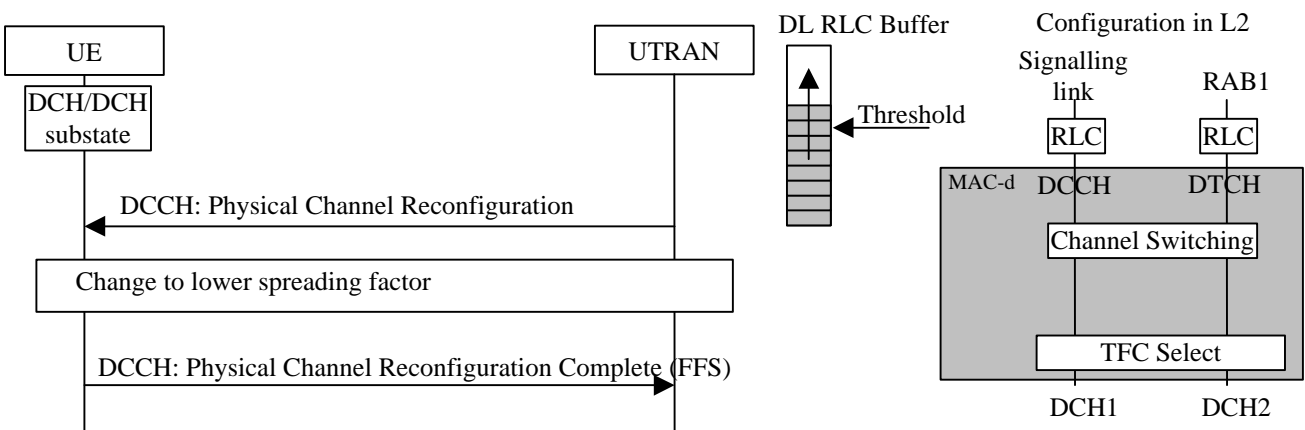

Figure 13 Physical channel reconfiguration triggered by increased DL data and configuration in UTRAN DL.

14.2.2.1 RRC Parameters in Physical Channel Reconfiguration

This message includes **new DL channelization codes** for the DPCH with lower spreading factor for all cells that the UE is connected to.

14.2.2.2 RRC Parameters in Physical Channel Reconfiguration Complete

No identified parameters

14.2.3 Decrease DL data, no Transport channel type switching

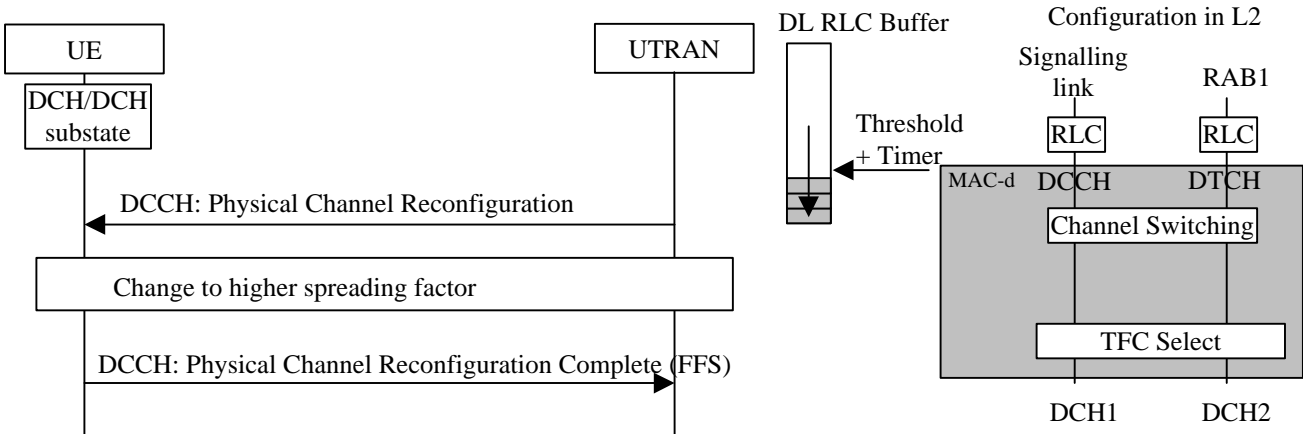

Figure 14 Physical channel reconfiguration triggered by decreased DL data and configuration in UTRAN DL.

14.2.3.1 RRC Parameters in Physical Channel Reconfiguration

This message includes new **DL channelization codes** for DPCH with higher spreading factor for all cells that the UE is connected to.

14.2.3.2 RRC Parameters in Physical Channel Reconfiguration Complete

No identified parameters

14.2.4 Decreased UL data, with switch from DCH/DCH to RACH/FACH

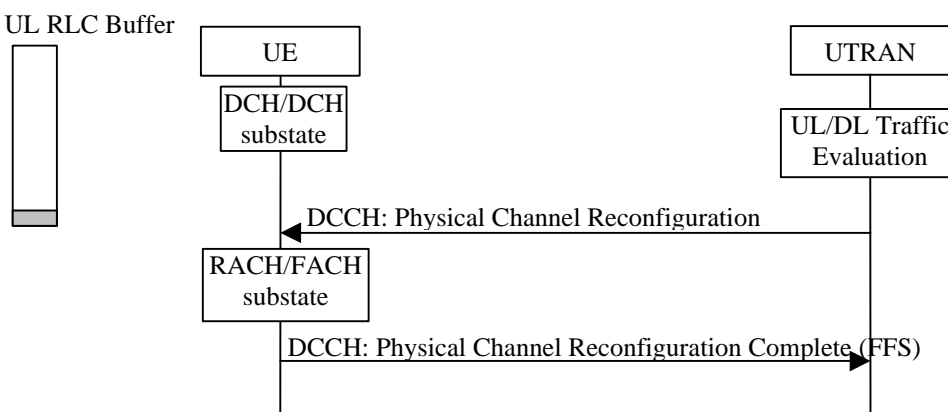

Figure 15 Physical channel reconfiguration triggered by decreased UL data and with a switch from DCH/DCH to RACH/FACH. Note: Whether the Physical Channel Reconfiguration Complete message is sent before or after entering RACH/FACH substate is FFS.

14.2.4.1 RRC Parameters in Physical Channel Reconfiguration

This message includes a **PRACH spreading factor** for the UL i.e. stating the minimum spreading factor to be used, and the **preamble signatures** that are allowed. Further, for the PRACH which **access slots** that are allowed and the **preamble spreading code** is included.

For the DL the message includes **scrambling code**, i.e. indicating to which cells FACH the UE should be connected to, and a **channelization code** for the secondary CCPCH.

[Note: The common channel parameters are the same that is transmitted on the BCCH. The reason to send it in this message is to remove the necessity for the UE to read BCCH at this switch.]

[Note: The necessity of an immediate cell-update when moving to RACH/FACH or if a valid RNTI is given to the UE before making the switch to allow immediate usage of DCCH is FFS.]

14.2.4.2 RRC Parameters in Physical Channel Reconfiguration Complete

No identified parameters

14.3 Examples of Transport Channel Reconfiguration

14.3.1 Increased UL data, with no transport channel type switching

In the example below, the UE is allowed to send more data in the UL when on dedicated transport channel, although the common transport channel configuration is still the same. To make use of the new transport format combinations the physical channel must also be reconfigured to allow a lower spreading factor.

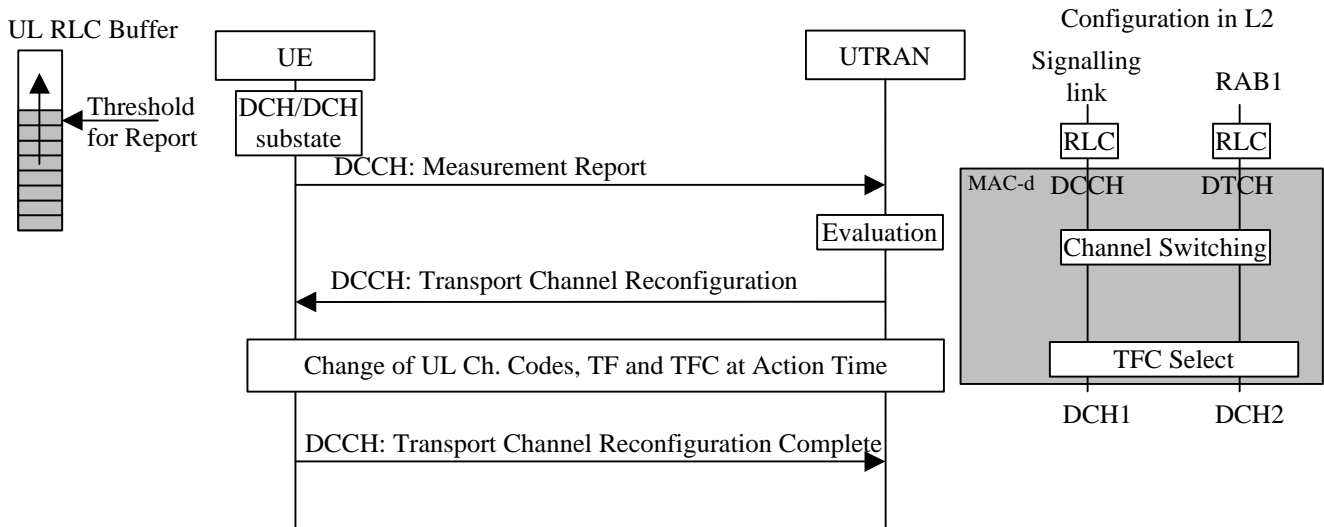

Figure 16 Transport channel reconfiguration triggered by increased UL data and configuration in UTRAN DL.

14.3.1.1 RRC Parameters in Measurement Report

This message includes a **Measurement Identity number** so that UTRAN can associate this report with a Measurement control message. It also includes the **Measurement result** stating what triggered the report and optionally the RLC buffer payload.

14.3.1.2 RRC Parameters in Transport Channel Reconfiguration

This message includes a new **Transport format set** for DCH2 and a new **Transport format combination set**. An **Activation time** must also be included if the different TFCIs can not coexist during the reconfiguration.

It also includes **UL channelization codes** for the DPCH.

14.3.1.3 RRC Parameters in Transport Channel Reconfiguration Complete

This message includes the identity of the reconfigured Transport channel, **DCH2**.

14.3.2 Decreased DL data, with switch from DCH/DCH to RACH/FACH

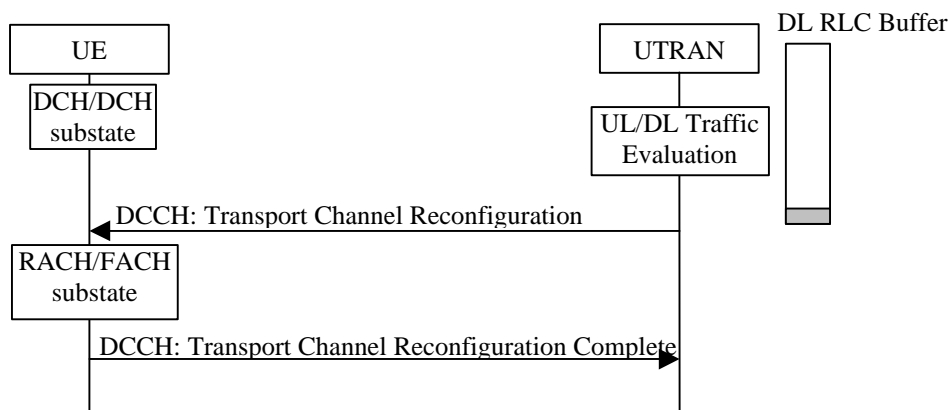

Figure 17 Transport channel reconfiguration triggered by decreased DL data and with a switch from DCH/DCH to RACH/FACH. Note: Whether the Transport Channel Reconfiguration Complete message is sent before or after entering RACH/FACH substate is FFS.

14.3.2.1 RRC Parameters in Transport Channel Reconfiguration

This message includes new **Transport format set for RACH**, a **PRACH spreading factor** i.e. stating the minimum spreading factor to be used, and the **preamble signatures** that are allowed. Further, for the PRACH which **access slots** that are allowed and the **preamble spreading code** is included.

For the DL the message includes a new **Transport format set for FACH**, the **scrambling code**, i.e. indicating to which cells FACH the UE should be connected to, and a **channelization code** for the secondary CCPCH.

[Note: The common channel parameters are the same that is transmitted at the BCCH. The reason to send it in this message is to remove the necessity for the UE to read BCCH at this switch.]

[Note: The necessity of an immediate cell-update when moving to RACH/FACH or if a valid RNTI is given to the UE before making the switch to allow immediate usage of DCCH is FFS.]

14.3.2.2 RRC Parameters in Transport Channel Reconfiguration Complete

This message includes the identity of the reconfigured transport channels, **RACH** and **FACH**.

14.4 Examples of RAB and Signalling link Reconfiguration

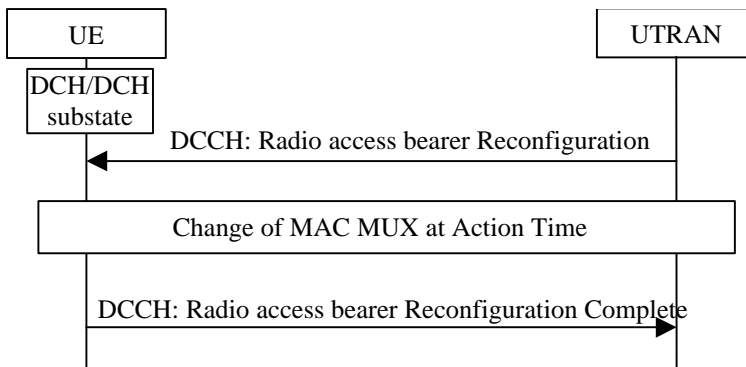

Figure 18 RAB reconfiguration.

14.4.1 RRC Parameters in Radio access bearer reconfiguration

This message includes a multiplexing option with **Transport channel identity DCH2 for both RAB1 and RAB2**, stating that both these RABs should use the same transport channel. For each of these two RABs a **Logical channel identity value** and a **priority** must be given to define the MAC MUX.

Also included is a new **Transport format set** for DCH2 and a new **Transport format combination set** (both for UL and DL if the multiplexing is changed both in UL and DL).

It is also possible to reconfigure the physical channel and include new **channelization codes** for the DPCH with different spreading factor for all cells that the UE is connected to.

14.4.2 RRC Parameters in Radio access bearer reconfiguration Complete

This message includes the **identities RAB1 and RAB2** to indicate that these RABs have been reconfigured. It also includes **transport channel identity DCH3** to indicate that this transport channel has been removed.

15 Appendix C (Flow-chart of a general scheme of the Soft Handover algorithm)

In this Appendix a flow-chart of the general scheme of Soft Handover algorithm described in section 6.1.1.5.2 is presented. As remarked in section 6.1.1.5.2, this scheme adopts the Signal Strength as a criterion; this is simply an example: other criteria such as SIR can be considered.

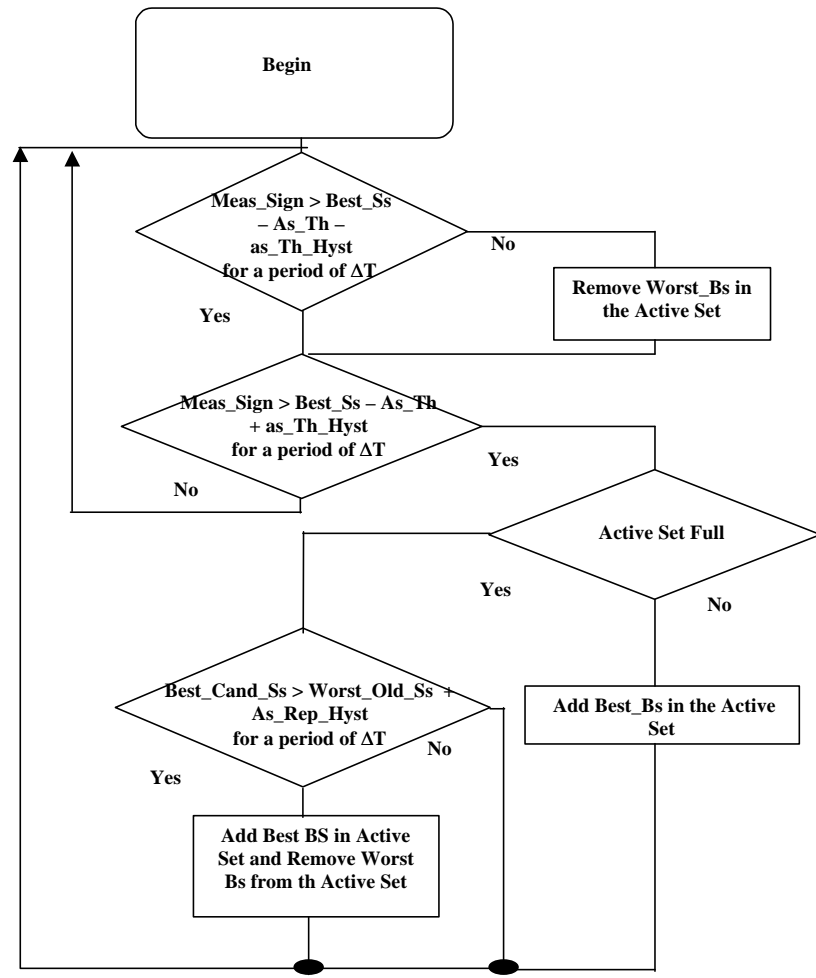

16 Appendix D (SSDT performance)

Site Selection Diversity Transmit Power (SSDT) is described in section 10.2.

Computer simulations were carried out to investigate the behaviour of SSDT under ETSI&ITU-R guidelines for IMT-2000 RTT evaluation. The results are compared to a conventional power control method, where the transmit power of all BS involved is controlled so that the correct target SIR value is reached.

The figure below shows capacity versus Doppler frequency for SSDT and conventional TPC (normal SHO). The simulations show that SSDT is superior to normal SHO at low speed, and that increases capacity by reducing overall interference. The capacity gains are approximately 40% without UE's diversity and 50% with UE's diversity at walking speed. At high mobile speed, the advantage of SSDT gradually diminishes. The performance degradation of SSDT at higher speed is caused by the limited update frequency of the primary cell id.

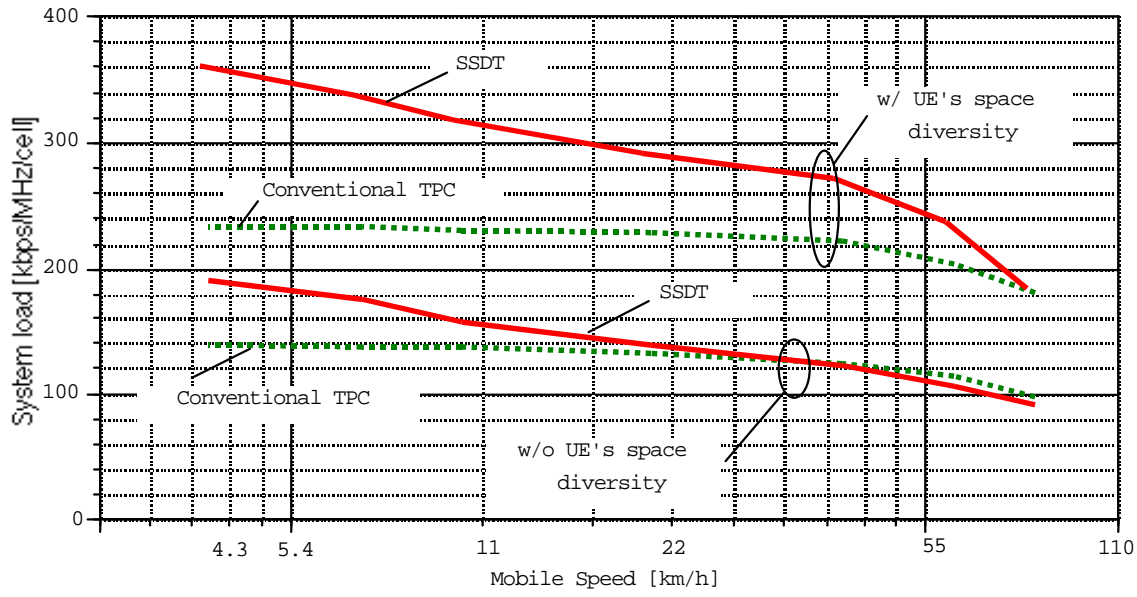

175 History

Document history		
Date	Version	Comment
August 1999	0.2.2	Inclusion of text from R299790; inclusion of a general scheme of Soft Handover as in R299791; inclusion of a section on mode control strategies for tx diversity as in R299793; inclusion of the definition of SSDT as in R299559
July 1999	0.2.1	Inclusion of section on code mode control with text for the AMR mode control from R299-601.
June 1999	0.2.0	The document was approved by e-mail and version raised to 0.2.0 for submission to TSG RAN.
May 1999	0.1.2	Message exchange and parameters used described for RAB control procedures from R299-251 were included in Appendix B; procedures related to power management for Variable Rate Packet Transmission from R2-99426 were included in Section 10.
April 1999	0.1.1	Inclusion of the input contributions 99/270, 99/246, 99/251. Approved by WG2. This document was submitted to TSG RAN and noted as version 0.1.1
April 1999	0.1.0	Document approved at Yokohama meeting
April 1999	0.0.3	Document reviewed after the comments provided during the meeting of Yokohama,

April 1999	0.0.2	Different parts from various documents of TSG RAN were included in the first draft version of TR R2.02.
March 1999	0.0.1	Document was created. A Scope and an index were added on the basis of td R2-99-182
Rapporteur for 3GPP TSG RAN WG2 TR 25.922 is:		
CSELT		
Daniele Franceschini		
Nicola Pio Magnani		
Tel.: +39 011 228 5203		
Tel.: +39 011 228 7089		
Fax: +39 011 228 7613		
Fax: +39 011 2287613		
e-mail: daniele.franceschini@cselt.it		
e-mail: nicola.magnani@cselt.it		
This document is written in Microsoft Word Version 97 SR-1 and saved in Rich Text Format.		