

**TSG-RAN Working Group 2 (Radio layer 2 and Radio layer 3)  
Berlin 25<sup>th</sup> to 28<sup>th</sup> April 1999**

*TSGR2#4(99)361*

**Agenda Item: 7.2  
Source: Editor**

**Title: 3GPP TSG RAN WG2 TR 25.922 V0.1.2: on "Radio Resource  
Management Strategies"**

**Document for: Discussion and decision**

**3<sup>rd</sup> Generation Partnership Project (3GPP);  
Technical Specification Group (TSG) RAN;  
Working Group 2 (WG2);**

**Radio Resource Management Strategies**

---

---

**Reference**

<Workitem> (<Shortfilename>.PDF)

---

**Keywords**

<keyword[, keyword]>

**3GPP**

---

**Postal address**

---

**Office address**

---

**Internet**

secretariat@3gpp.org  
Individual copies of this deliverable  
can be downloaded from  
<http://www.3gpp.org>

---

**Copyright Notification**

No part may be reproduced except as authorized by written permission.  
The copyright and the foregoing restriction extend to reproduction in all media.

©  
All rights reserved.

---

# Contents

<b>INTELLECTUAL PROPERTY RIGHTS</b>	<b>6</b>
<b>FOREWORD</b>	<b>6</b>
<b>1. SCOPE</b>	<b>6</b>
<b>2. REFERENCES</b>	<b>6</b>
<b>3. DEFINITIONS, ABBREVIATIONS AND SYMBOLS</b>	<b>7</b>
3.1 Definitions	7
3.2 Abbreviations	7
3.3 Symbols	8
<b>4. GENERAL DESCRIPTION OF RADIO RESOURCE MANAGEMENT</b>	<b>8</b>
<b>5. IDLE MODE TASKS</b>	<b>8</b>
5.1 Overview	8
5.2 Service type in Idle mode	9
5.3 Criteria for Cell Selection and Reselection	9
5.3.1 Cell Selection Monitoring Frequency or Cell Set	9
5.3.2 Cell Re-Selection Monitoring Frequency or Cell Set	9
5.4 Location Registration	9
5.5 Broadcast information receiving	9
<b>6. RRC CONNECTION MOBILITY</b>	<b>9</b>
6.1 General Description of Connected Mode	9
6.1.1 Handover	9
6.1.1.1 Strategy	9
6.1.1.2 Causes	10
6.1.1.3 Cell Set for the Handover Preparation	10
6.1.1.4 Hard Handover	10
6.1.1.4.1 Hard Handover (FDD and TDD Hard)	10
6.1.1.5 Soft Handover	10
6.1.1.6 Inter System Handover	12

6.1.1.6.1	Handover 3G to 2G	12
6.1.2	Radio Link Management	13
<b>7.</b>	<b>ADMISSION CONTROL</b>	<b>14</b>
7.1	Overall strategies	14
	Other mapping are possible like for instance:	14
7.2	Scenarios	14
7.2.1	CAC performed in SRNS	14
7.2.2	CAC performed in DRNC	15
7.2.2.1	Case of DCH	15
7.2.2.2	Case of Common Transport Channels	16
<b>8.</b>	<b>RADIO ACCESS BEARER CONTROL</b>	<b>17</b>
8.1	Radio Access Bearer Control – Overview of Procedures	17
8.2	Usage of RAB control procedures	17
8.2.1	Example of Radio Access Bearer Setup	17
8.2.2	Examples of Physical Channel Reconfiguration	18
8.2.2.1	Increased UL data, with switch from RACH/FACH to DCH/DCH	18
8.2.2.2	Increased DL data, no Transport channel type switching	19
8.2.2.3	Decrease DL data, no Transport channel type switching	19
8.2.2.4	Decreased UL data, with switch from DCH/DCH to RACH/FACH	19
8.2.3	Examples of Transport Channel Reconfiguration	20
8.2.3.1	Increased UL data, with no transport channel type switching	20
8.2.3.2	Decreased DL data, with switch from DCH/DCH to RACH/FACH	21
8.2.4	Example of RAB and Signalling link Reconfiguration	21
8.3	RRC Elementary Procedures	22
<b>9.</b>	<b>DYNAMIC CHANNEL ALLOCATION</b>	<b>22</b>
9.1	DCA (FDD)	22
9.1.1	Radio Resource Allocation Tasks (RACH/FACH and RACH+FAUSCH/FACH)	22
9.1.2	Radio Resource Allocation tasks (DCH/DCH and DCH/DCH+DSCH)	22
9.2	DCA (TDD)	23
9.2.1	Channel Allocation	23
9.2.1.1	Resource allocation to cells (slow DCA)	23
9.2.1.2	Resource allocation to bearer services (fast DCA)	23
9.2.2	Measurements Reports from UE to the UTRAN	24
<b>10.</b>	<b>POWER MANAGEMENT</b>	<b>24</b>
<b>11.</b>	<b>RADIO LINK SURVEILLANCE</b>	<b>24</b>

<b>12. APPENDIX A</b>	<b><u>24</u></b>
<b>12.1 Simulation environment</b>	<b><u>25</u></b>
<b>12.2 Results</b>	<b><u>25</u></b>
12.2.1 Macro UDD 144	<u>25</u>
12.2.2 Micro UDD 384	<u>26</u>
12.2.2.1 Code rate 1	<u>26</u>
12.2.2.2 Code rate 2/3	<u>27</u>
<b>12.3 Conclusions</b>	<b><u>28</u></b>
<b>13. HISTORY</b>	<b><u>28</u></b>

---

## Intellectual Property Rights

IPRs essential or potentially essential to the present deliverable may have been declared to 3GPP and/or its organizational partners. The information pertaining to these essential IPRs, if any, is publicly available for 3GPP **members and non-members, free of charge**. This can be found in the latest version of the 3GPP Technical Report: [tbd.].

Pursuant to the 3GPP Interim IPR Policy, no investigation, including IPR searches, has been carried out by 3GPP. No guarantee can be given as to the existence of other IPRs not referenced in the [tbd.], which are, or may be, or may become, essential to the present document.

*[Editor's note: This section needs to be reviewed. It is assumed here that a 3GPP IPR report will be available in the near future.]*

---

## Foreword

This Technical Recommendation has been produced by the 3<sup>rd</sup> Generation Partnership Project, Technical Specification Group RAN.

The contents of this TR may be subject to continuing work within the 3GPP and may change following formal TSG approval. Should the TSG modify the contents of this TR, it will be re-released with an identifying change of release date and an increase in version number as follows:

Version m.t.e

where:

- m indicates [major version number]
- x the second digit is incremented for all changes of substance, i.e. technical enhancements, corrections, updates, etc.
- y the third digit is incremented when editorial only changes have been incorporated into the specification.

---

## 1. Scope

The present document shall describe RRM strategies supported by UTRAN specifications and typical algorithms.

---

## 2. References

The following documents contain provisions which, through reference in this text, constitute provisions of the present document.

- References are either specific (identified by date of publication, edition number, version number, etc.) or non-specific.
- For a specific reference, subsequent revisions do not apply.
- For a non-specific reference, the latest version applies.
- A non-specific reference to an TS shall also be taken to refer to later versions published as an EN with the same number.

[1] 3GPP Homepage: [www.3gpp.org](http://www.3gpp.org)

[2] S2.01, Radio Interface Protocol Architecture

[3] S2.02, Layer 1; General requirements

[4] S2.03, UE States and Procedures in Connected Mode

[5] S2.04, Description of procedures in idle Mode

- [6] S2.22, Description of RLC protocol
- [7] S2.31, Description of RRC protocol
- [8] S2.40, Description of principles for error handling and message description
- [9] ETSI UMTS 25.XX: "Vocabulary for the UTRAN"
- [10] S1.25, Measurements TDD

---

## 3. Definitions, abbreviations and symbols

### 3.1 Definitions

See [9] for a definition of fundamental concepts and vocabulary.

### 3.2 Abbreviations

ARQ	Automatic Repeat Request
BCCH	Broadcast Control Channel
BCH	Broadcast Channel
C-	Control-
CC	Call Control
CCCH	Common Control Channel
CCH	Control Channel
CCTrCH	Coded Composite Transport Channel
CN	Core Network
CRC	Cyclic Redundancy Check
DC	Dedicated Control (SAP)
DCA	Dynamic Channel Allocation
DCCH	Dedicated Control Channel
DCH	Dedicated Channel
DL	Downlink
DRNC	Drift Radio Network Controller
DSCH	Downlink Shared Channel
DTCH	Dedicated Traffic Channel
FACH	Forward Link Access Channel
FAUSCH	Fast Uplink Signalling Channel
FCS	Frame Check Sequence
FDD	Frequency Division Duplex
GC	General Control (SAP)
HO	Handover
ITU	International Telecommunication Union
kbps	kilo-bits per second
L1	Layer 1 (physical layer)
L2	Layer 2 (data link layer)
L3	Layer 3 (network layer)
LAC	Link Access Control
LAI	Location Area Identity
MAC	Medium Access Control
MM	Mobility Management
Nt	Notification (SAP)
OCCCH	ODMA Common Control Channel



ODCCH	ODMA Dedicated Control Channel
ODCH	ODMA Dedicated Channel
ODMA	Opportunity Driven Multiple Access
ORACH	ODMA Random Access Channel
ODTCH	ODMA Dedicated Traffic Channel
PCCH	Paging Control Channel
PCH	Paging Channel
PDU	Protocol Data Unit
PHY	Physical layer
PhyCH	Physical Channels
RACH	Random Access Channel
RLC	Radio Link Control
RNC	Radio Network Controller
RNS	Radio Network Subsystem
RNTI	Radio Network Temporary Identity
RRC	Radio Resource Control
SAP	Service Access Point
SCCH	Synchronization Control Channel
SCH	Synchronization Channel
SDU	Service Data Unit
SRNC	Serving Radio Network Controller
SRNS	Serving Radio Network Subsystem
TCH	Traffic Channel
TDD	Time Division Duplex
TFCI	Transport Format Combination Indicator
TFI	Transport Format Indicator
TMSI	Temporary Mobile Subscriber Identity
TPC	Transmit Power Control
U-	User-
UE	User Equipment
UE <sub>R</sub>	User Equipment with ODMA relay operation enabled
UL	Uplink
UMTS	Universal Mobile Telecommunications System
URA	UTRAN Registration Area
UTRA	UMTS Terrestrial Radio Access
UTRAN	UMTS Terrestrial Radio Access Network

### 3.3 Symbols

---

## 4. General Description of Radio resource Management

---

## 5. Idle Mode Tasks

### 5.1 Overview

[A complete overview of idle mode tasks is contained in section 4.1 of S2.04. For the purpose of this recommendation some specific test will be developed.]

## 5.2 Service type in Idle mode

[In this section, the impact of service type on RRM strategies will be addressed, also based on section 4.3 of S2.04]

Services are distinguished into categories defined in section 4.3 of S2.04; also the categorisation of cells according to services they can offer is provided in section 4.3 of S2.04. In the following, some typical examples of the use of the different types of cells are provided.

Low priority suitable cells.

These may be used for the support of multilayered networks.

“operator only” cell.

The aim of this type of cell is to allow the operator using and test newly deployed cells without being disturbed by normal traffic.

## 5.3 Criteria for Cell Selection and Reselection

### 5.3.1 Cell Selection Monitoring Frequency or Cell Set

### 5.3.2 Cell Re-Selection Monitoring Frequency or Cell Set

## 5.4 Location Registration

The location registration procedure is defined in S2.04. The strategy used for the update of the location registration has to be set by the operator and, for instance, can be done regularly and when entering a new registration area. The same would apply for the update of the NAS defined service area which can be performed regularly and when entering a new NAS defined service area.

## ~~5.4~~5.5 Broadcast information receiving

[In this section the possible uses of broadcast system information on RRM strategies will be addressed also based on section 6 of S2.04]

---

# 6. RRC Connection Mobility

## 6.1 General Description of Connected Mode

[The overall description of the connected mode is contained in section 4 of S2.03. For the purpose of this recommendation some specific test will be developed.]

### 6.1.1 Handover

#### 6.1.1.1 Strategy

The handover strategy employed by the network for radio link control determines the handover decision that will be made based on the measurement results reported by the UE/RNC and various parameters set for each cell. Network directed handover might also occur for reasons other than radio link control, e.g. to control traffic distribution between cells. The network operator will determine the exact handover strategies.. Possible types of Handover are as follows:

- Handover 3G -3G;
- FDD soft/softer handover;
  - FDD inter-frequency hard handover;
  - FDD/TDD Handover;
- TDD/FDD Handover;
- TDD/TDD Handover;
- Handover 3G - 2G;
- Handover to GSM

### 6.1.1.2 Causes

The following is a non-exhaustive list for causes for the initiation of a handover process.

- Uplink quality
- Uplink signal strength
- Downlink quality
- Downlink signal strength
- Distance
- Change of service
- Better cell
- O&M intervention
- Directed retry
- Traffic
- Pre-emption

### 6.1.1.3 Cell Set for the Handover Preparation

### 6.1.1.4 Hard Handover

#### 6.1.1.4.1 Hard Handover (FDD and TDD Hard)

*[Test to be deployed also based on section 7.3.7 of S2.03]*

The hard handover procedure is defined in section 7.3.7 of S2.03.

Two main strategies can be used in order to determine the need for an hard handover:

- received measurements reports
- load control

### 6.1.1.5 Soft Handover

The serving cell (s) (the cells in the active set) are expected to have knowledge of the service used by the UE. The new cell decided to be added to the active set shall be informed that a new connection is desired, and it needs to have the following minimum information forwarded to it via UTRAN.

- Maximum data rate of the connection and other service parameters, such as coding schemes, number of parallel code channels etc. parameters which form the set of parameters describing the different transport channel configurations in use both uplink and downlink.
- The UE ID and uplink scrambling code
- The relative timing information of the new cell, in respect to the timing UE is experiencing from the existing connections (as measured by the UE at its location). Based on this the new cell can determine what should be the timing of the transmission initiated in respect to the timing of the common channels (BCCH) of the new cell.

As a response the UE needs to know via the existing connections:

- From which frame (assuming active set update accepted) does the new cell initiate the transmission to the UE

- What channelisation code(s) are used for that transmission. The channelisation codes from different cells are not required to be the same as they are under different scrambling code anyway.
- The relative timing information, which needs to be made available at the new cell is indicated in Figure 1 (shows the case where the two involved cells are managed by different Node Bs).

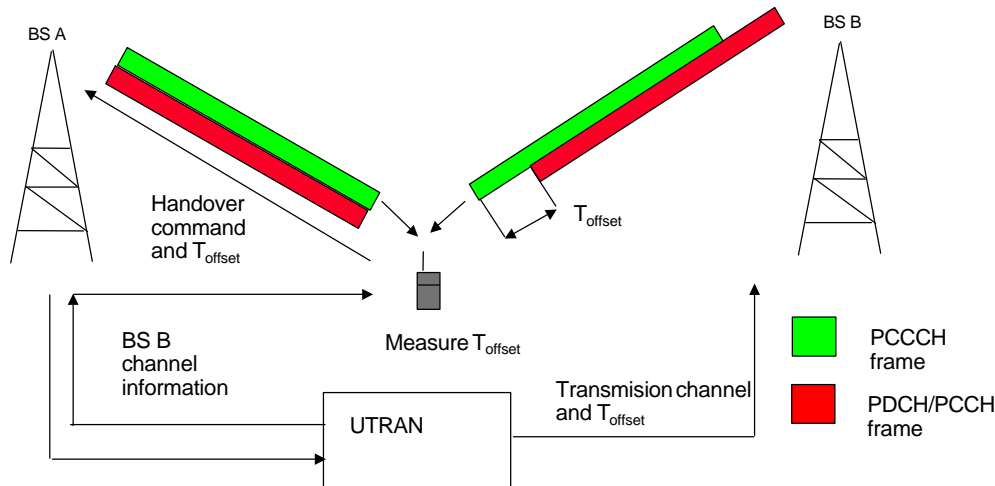

**Figure 1.** Making transmissions capable to be combined in the Rake receiver from timing point of view.

At the start of diversity handover, the reverse link dedicated physical channel transmitted by the MS, and the forward link dedicated physical channel transmitted by the diversity handover source BTS will have their radio frame number and scrambling code phase counted up continuously as usual, and they will not change at all. Naturally, the continuity of the user information mounted on them will also be guaranteed, and will not cause any interruption.

*[Editor's Note: it is F.F.S if the following parts on synchronization are relevant for R2.02]*

*<Editor's note : text from ARIB, volume 3>*

The synchronization timing upon starting diversity handover are presented in Fig. 3.2.5-4. The synchronisation establishment flow upon intra/inter-cell diversity handover is described in Fig. 3.2.6-4.

The MS measures the frame time difference of the radio frame at the same frame number between the reverse link dedicated physical channel and the perch channel transmitted at the handover destination BTS. These measurements shall be notified to the network. The measured value is the time difference of the frame timing of the reverse link dedicated physical channel against the frame timing of the perch channel. The values shall always be positive values in chip units, and the range shall be 0 ~ "reverse link scrambling code cycle-1" chip.

The MS notifies the frame time difference measurement values as layer 3 signals to the BSC via the diversity handover source BTS with the DCH of the reverse link dedicated physical channel.

The BSC notifies the frame time difference measurement result, together with the frame offset and slot offset set up upon originating/ terminating call connection, to the diversity handover destination BTS with layer 3 signals. Furthermore, the BSC notifies radio parameters such as the spreading codes used at the handover destination BTS etc., to the MS via the handover source BTS.

The MS starts the chip synchronisation establishment process of forward link channel from the handover destination BTS with the notified radio parameters. The reverse link channels being transmitted shall continue transmission without any operations performed.

The handover destination BTS receives the notification of the above frame time difference frame offset, and slot offset. Utilising these informations, the BTS starts the transmission of forward link dedicated physical channels and starts the

synchronization establishment process of reverse link dedicated physical channel transmitted by the MS. See chapter 3.2.5.1 for the specific transmission timing of forward link dedicated physical channels, and the reception timing of reverse link dedicated physical channel. As soon as chip synchronisation and frame synchronisation using Frame Synchronization Word are established, hard wired transmission shall be started.

Based on the handover destination perch channel reception timing, the MS establishes chip synchronisation of forward link channel from handover destination BTS. As soon as chip synchronisation is established, maximal ratio combining with the forward link channel from handover source BTS shall be started.

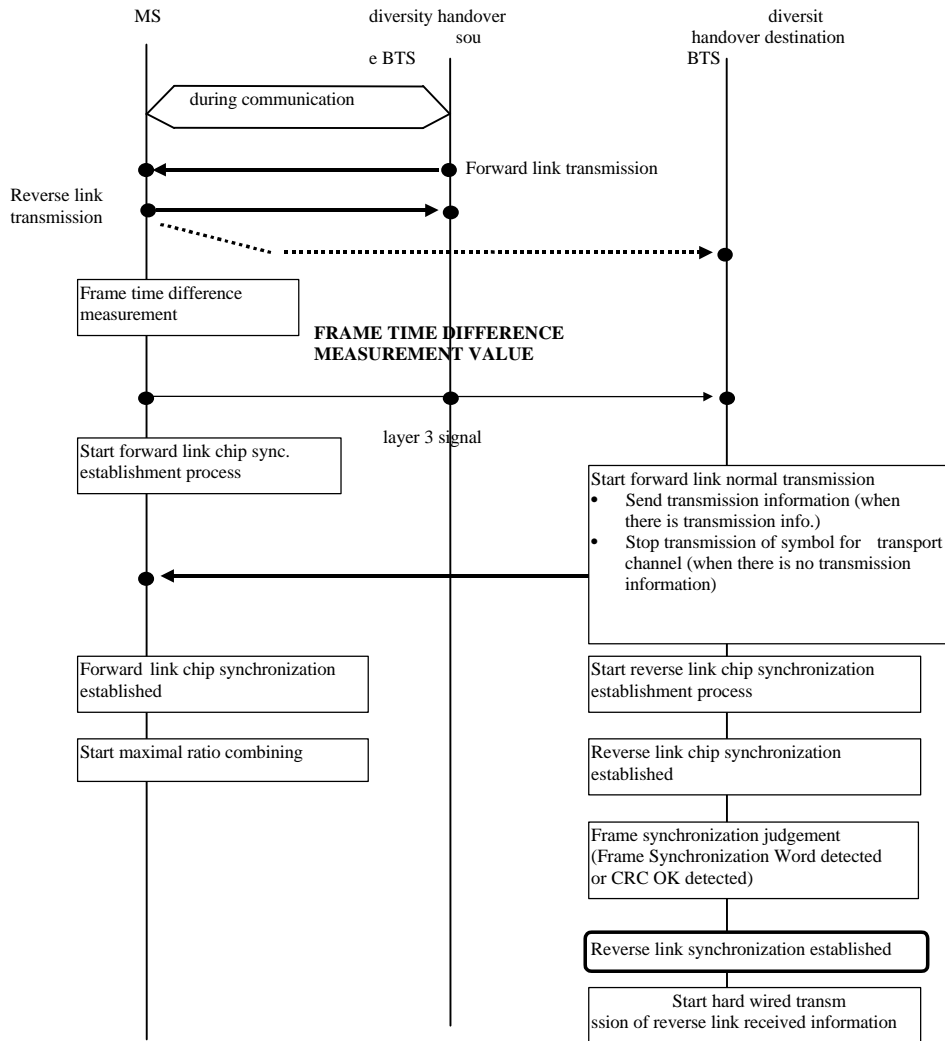

Figure 2 Synchronisation Establishment Flow Upon Intra/Inter-cell Diversity Handover

### 6.1.1.6 Inter System Handover

#### 6.1.1.6.1 Handover 3G to 2G

The handover between UTRA and GSM system offering world-wide coverage already today has been one of the main design criteria taken into account in the UTRA frame timing definition. The GSM compatible multi-frame structure, with the super-frame being multiple of 120 ms, allows similar timing for inter-system measurements as in the GSM system itself. The compatibility in timing is important, that when operating in UTRA mode, a multi-mode UE is able to catch the desired information from the synchronization bursts in the synchronization frame on a GSM carrier with the aid of the frequency correction burst. This way the relative timing between a GSM and UTRA carriers is maintained similar to the timing between two asynchronous GSM carriers.

UTRA/FDD-GSM dual mode UEs can be implemented without simultaneous use of two receiver chains. Although the frame length is different from GSM frame length, the GSM traffic channel and UTRA FDD channels use similar 120 ms multi-frame structure. Similar timing can be naturally done with UTRA TDD mode as well.

A UE can do the measurements by using idle periods in the downlink transmission, where such idle periods are created by using the downlink slotted mode as defined in reference [2]. In addition to downlink slotted frames for measurements, the UTRAN will provide uplink slotted frames to allow the UE to GSM cells on frequencies closed to the FDD uplink band. The slotted mode is under the control of the UTRAN, and the UTRAN should communicate to the UE which frame is slotted. .

Alternatively independent measurements not relying on the slotted mode, but using a dual receiver approach can be performed, where the GSM receiver branch can operate independently of the UTRA FDD receiver branch.

For smooth inter-operation between the systems, information needs to be exchanged between the systems, in order to allow the UTRAN to notify the UE of the existing GSM frequencies in the area ( see section 6.1.1.2.1.4). Further more integrated operation is needed for the actual handover where the current service is maintained, taking naturally into account the lower data rate capabilities in GSM when compared to UTRA maximum data rates reaching all the way to 2 Mbits/s.

UTRA/TDD-GSM dual mode terminals can be implemented without simultaneous use of two receiver chains. Although the frame length is different from GSM frame length, the GSM traffic channel and UTRA TDD channels rely on similar 120 ms multi-frame structure.

A UE can do the measurements either by efficiently using idle slots or by requesting free continuous periods in the downlink part obtained by reducing the spreading factor and compressing in time TS occupation in a form similar to the FDD slotted mode. The low-cost constraint excludes the dual receiver approach.

For smooth inter-operation, inter-system information exchanges are needed in order to allow The UTRAN to notify the UE of the existing GSM frequencies in the area and vice versa. Further more integrated operation is needed for the actual handover where the current service is maintained, taking naturally into account the lower data rate capabilities in GSM when compared to UMTS maximum data rates reaching all the way to 2 Mbits/s.

Basic requirements to correctly perform a handover in GSM are described in GSM 05.08 "Radio subsystem link control".

## 6.1.2 Radio Link Management

*[Test to be deployed also based on sections 7.3.4, 7.3.5, 7.3.6 of S2.03]*

### 6.1.2.1 Radio Link Addition (FDD soft-add)

The radio link addition procedure is defined in section 7.3.4 of S2.03.

Basically, the strategies that can be used in order to determine the need for radio link addition are based on the received measurements reports sent by the UE.

### 6.1.2.2 Radio Link Removal (FDD soft-drop)

The radio link removal procedure is defined in section 7.3.5 of S2.03.

Two main strategies can be used in order to determine the need for a radio link removal:

- received measurements reports sent by the UE

- [load control](#)

### 6.1.2.3 Combined Radio Link addition and removal

The combined radio link addition and removal procedure is defined in section 7.3.6 of S2.03.

Two main strategies can be used in order to determine the need for a combined radio link addition and removal:

- [received measurements reports sent by the UE](#)
- [load control](#)

## 7. Admission Control

### 7.1 Overall strategies

**Principle 1:** Admission Control is performed according to the type of required QoS.

“Type of service” is to be understood as an implementation specific category derived from standardized QoS parameters.

The following table illustrates the concept :

Service	Domain	Transport Channel	Type of service	CAC performed
Voice	CS	DCH	Premium*	YES
	IP	DCH	Premium*	YES
Web	IP	DSCH	Assured Service**	YES
	IP	DSCH	Best Effort***	NO

\* *Premium service:* Low delay, high priority.

\* *Assured Service:* A minimum rate below the mean rate is guaranteed, service may use more bandwidth if available, medium priority.

\* *Best Effort:* No guaranteed QoS, low priority.

Other mapping are possible like for instance:

PSTN domain: Premium service, IP domain: Best Effort.

**Assumption:** Admission Control is performed by CRNC under request from SRNC.

[Editor'S note, other criteria/principles are FFS]

### 7.2 Scenarios

#### 7.2.1 CAC performed in SRNS

[Figure 3](#) [Figure 3](#) [Figure 3](#) is to be taken as an example. It describes the general scheme that involves Admission Control.

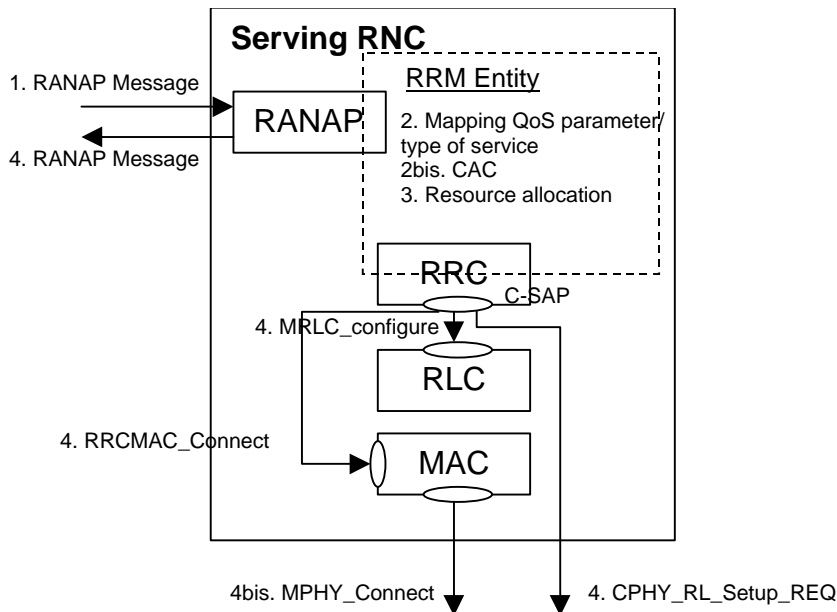

**Figure 3: This model shows how standardized RANAP and RRC layers are involved in the CAC process. The dashed box represents a proprietary entity.**

1. CN requests SRNC for establishing a RAB, indicating QoS parameters.
2. According to QoS parameters the requested service is assigned a type of service. CAC is performed according to the type of service.
3. Resources are allocated according to the result of CAC.
4. Acknowledgement is sent back to CN according to the result of CAC. Sub\_layers are configured accordingly.

Steps 2 to 4 may also be triggered by SRNC for reconfiguration purpose within the SRNC (handovers intra-RNC, channels reconfigurations, location updates).

## 7.2.2 CAC performed in DRNC

*As CAC is always performed in CRNC it occurs in DRNC when Iur is to be used (soft handover, Cell/URA Update). [Editor's note please clarify the content of this sentence]*

### 7.2.2.1 Case of DCH



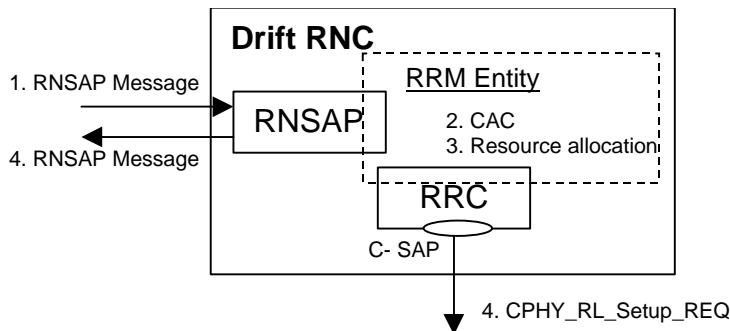
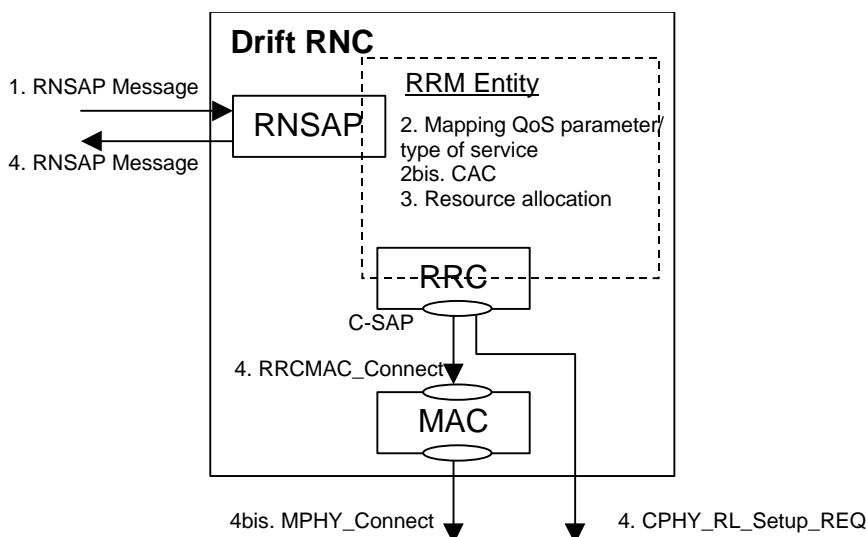

**Figure 444:** This model shows how standardized RNSAP and RRC layers are involved in the CAC process. The dashed box represents a proprietary entity.

1. SRNC requests DRNC for establishing a Radio Link, indicating DCH characteristics. These implicitly contains all QoS requirements and are enough as inputs to the CAC algorithm.
2. CAC is performed according to DCH characteristics.
3. Resources are allocated according to the result of CAC.
4. Acknowledgement is sent back to CN according to the result of CAC.

### 7.2.2.2 Case of Common Transport Channels

When transmitting packets on Common Transport Channels a UE may camp on a new cell managed by a new RNC. SRNC is notified by UE through RRC messages that connection will be set up through a new DRNC. Subsequently SRNC initiates connection through new DRNC.



**Figure 555:** This model shows how standardized RNSAP and RRC layers are involved in the CAC process. The dashed box represents a proprietary entity.

1. SRNC requests DRNC for establishing a Radio Link. A RNSAP message contains the QoS parameters and the type of Common Transport Channel to be used.
2. According to QoS parameters the requested service is assigned a type of service. CAC is performed according to the type of service and to the type of Common Transport Channel requested by SRNC.
3. Resources are allocated according to the result of CAC.
4. Acknowledgement is sent back to CN according to the result of CAC. L1 and MAC are configured accordingly by RRC layer.

The RNSAP procedure is to be handled if a certain QoS is required. It may be avoided if the service just needs Best Effort. The decision to trigger the RNSAP procedure is to be taken by SRNC.

---

## 8. Radio Access Bearer Control

### 8.1 Radio Access Bearer Control – Overview of Procedures

*[Test to be deployed also based on section 6.1 of S2.03]*

### 8.2 Usage of RAB control procedures

Radio access bearer control procedures are used to control the UE and system resources. This section explains how the system works with respect to these procedures and how e.g. traffic volume measurements could trigger these procedures.

First a Radio access bearer setup is shown, where pre-configuration of transport channels are exemplified. Further, the procedures Physical channel reconfiguration and Transport channel reconfiguration are shown in several examples. It is also explained how these last two procedures are used in the system for resource control of services with variable bitrate, i.e. transport channel type switching. Finally, usage of Radio access bearer reconfiguration is shown in an example where the MAC multiplexing is changed.

#### 8.2.1 Example of Radio Access Bearer Setup

In order to set up a new Radio access bearer a RRC connection must have been established, and some NAS negotiation has been performed. The Radio access bearer setup message comes from UTRAN and depending on the requirement of the service a common or a dedicated transport channel could be used. In the example below the UE is using a common transport channel for the RRC connection and stays on the common transport channel after the RAB setup.

However, transport channel parameters such as transport formats and transport format combinations are configured not only for the used common transport channel, but also for dedicated transport channel for future use.

All physical parameters are the same before and after the RAB setup in this example.

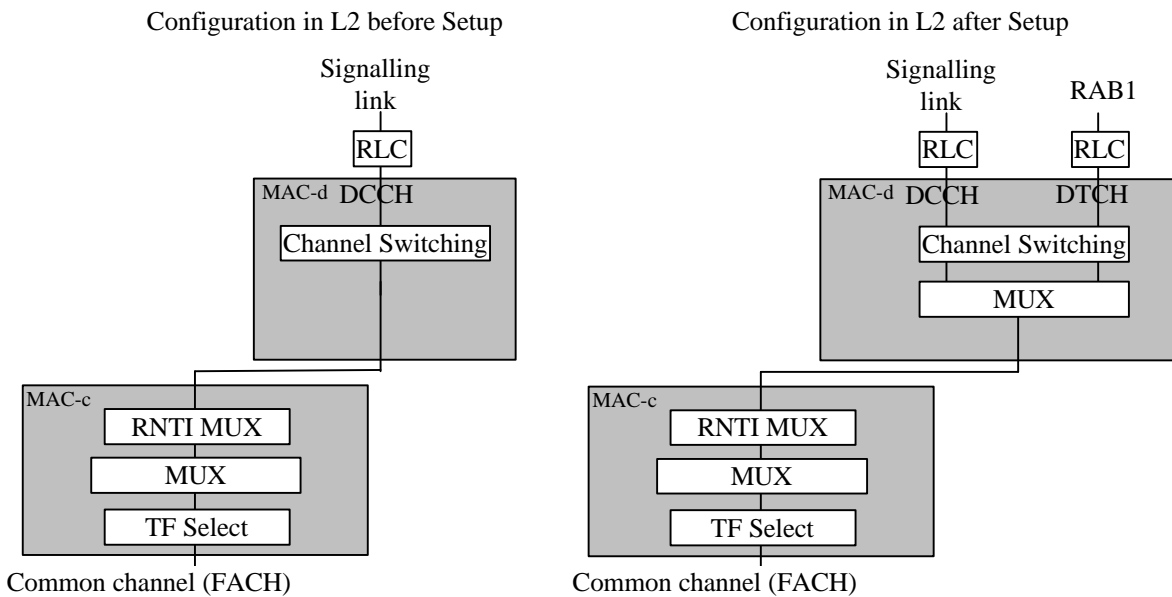

**Figure 666 Configuration of L2 in the UTRAN DL before and after the RAB setup.**

## 8.2.2 Examples of Physical Channel Reconfiguration

This RRC procedure is used to reconfigure the Physical channel and can by that also trigger Transport channel type switching. Below several examples of Physical Channel reconfigurations are shown, triggered by different amount of UL or DL data.

### 8.2.2.1 Increased UL data, with switch from RACH/FACH to DCH/DCH

A UE that is in the RACH/FACH substate can transmit a small amount of user data using the common transport channels. For larger amounts it is more appropriate to use a dedicated transport channel. Since each UE doesn't know the total load situation in the system UTRAN decides if a UE should use common transport channels or a dedicated transport channel.

The monitoring of UL capacity need is handled by a UTRAN configured measurement in the UE. When the amount of data in the RLC buffer to be transmitted in the UL increases over a certain threshold the UE sends a measurement report to UTRAN. This threshold to trigger the report is normally given in System Information, but UTRAN can also control the threshold in a UE dedicated Measurement Control message.

Since, UTRAN has the current status of the total UL need it can decide which UEs that should be switched to a dedicated transport channel. If UTRAN has pre-configured the transport formats and transport format combinations to be used on the dedicated transport channel for the UE, a Physical channel reconfiguration procedure could be used to assign dedicated physical resources.

The spreading factor for the physical channels assigned then give, which transport format combinations that are allowed to use.

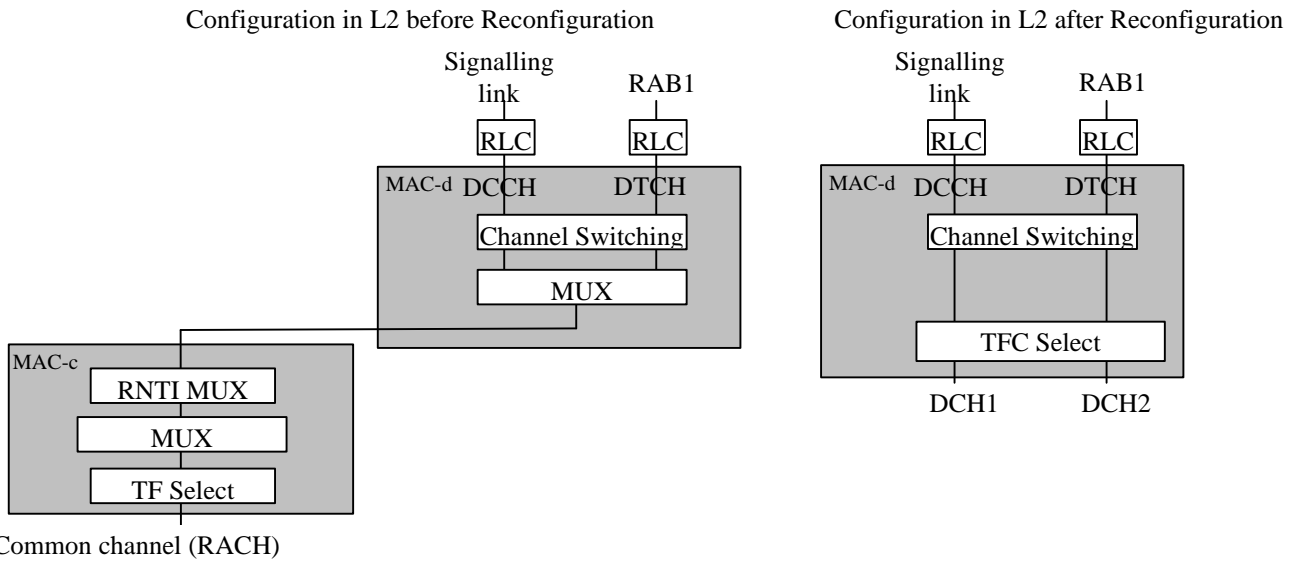

Figure 777 Configuration in the UTRAN UL before and after the Physical channel reconfiguration.

### 8.2.2.2 Increased DL data, no Transport channel type switching

If the RLC buffer increases above a certain threshold [Note: This is only one of many possible implementations of the network] in the network the UTRAN can do a physical channel reconfiguration. Here the UE uses a dedicated transport channel, and this procedure is used to decrease the spreading factor of the physical dedicated channel. This way this variable bitrate service increases the throughput on the downlink.

A variable bitrate service that has large traffic variations should have transport formats and transport format combinations defined for lower spreading factors than currently used on the physical channel. Then after the physical channel reconfiguration that lowers the spreading factors these transport formats and transport format combinations could be used to increase the throughput for this user.

However, if the transport formats and transport format combinations have not been previously defined to support a lower spreading factor, a Transport channel reconfiguration must be used instead in order to get any increased throughput.

Only downlink physical parameters are changed here since the uplink in this scenario doesn't need to increase its capacity.

### 8.2.2.3 Decrease DL data, no Transport channel type switching

Since downlink channelization codes are a scarce resource a UE with a too high, allocated gross bit rate (low spreading factor) must be reconfigured and use a more appropriate channelization code (with higher spreading factor). This could be triggered by a threshold for the RLC buffer content and some inactivity timer, i.e. that the buffer content stays a certain time below this threshold. [Note: This is only one of many possible implementations of the network].

After the physical channel has been reconfigured, some of the transport formats and transport format combinations that require a low SF can not be used. However, these are stored and could be used if the physical channel is reconfigured later to use a lower spreading factor.

### 8.2.2.4 Decreased UL data, with switch from DCH/DCH to RACH/FACH

In the network the UE traffic can be evaluated and the network can observe which transport format combinations that are used in the UL. The network could also simply look at how much data the UE transmits or use measurement reports [Note: Which way for the network to trigger this is a matter of implementation].

If the UE is transmitting a low amount of data in the uplink and there is little traffic in the downlink, this could trigger a switch from a dedicated transport channel to a common transport channel. Depending on if the already defined RACH/FACH

configuration is possible/preferred in the cell that the UE will be in after the switch, a Transport channel reconfiguration or a Physical channel reconfiguration procedure is used.

In the example below the UE has stayed in cells with a similar RACH and FACH configuration when using a dedicated transport channel. Therefore, the Physical channel reconfiguration procedure can be used. In 8.2.3.2 this is not the case and a Transport channel reconfiguration is used instead.

After the UE has performed the transport channel type switch to the RACH/FACH substate, all transport channel parameters such as transport formats for the dedicated transport channel are stored. The same configuration of the dedicated transport channels could then be reused if the UE switches back to the DCH/DCH substate.

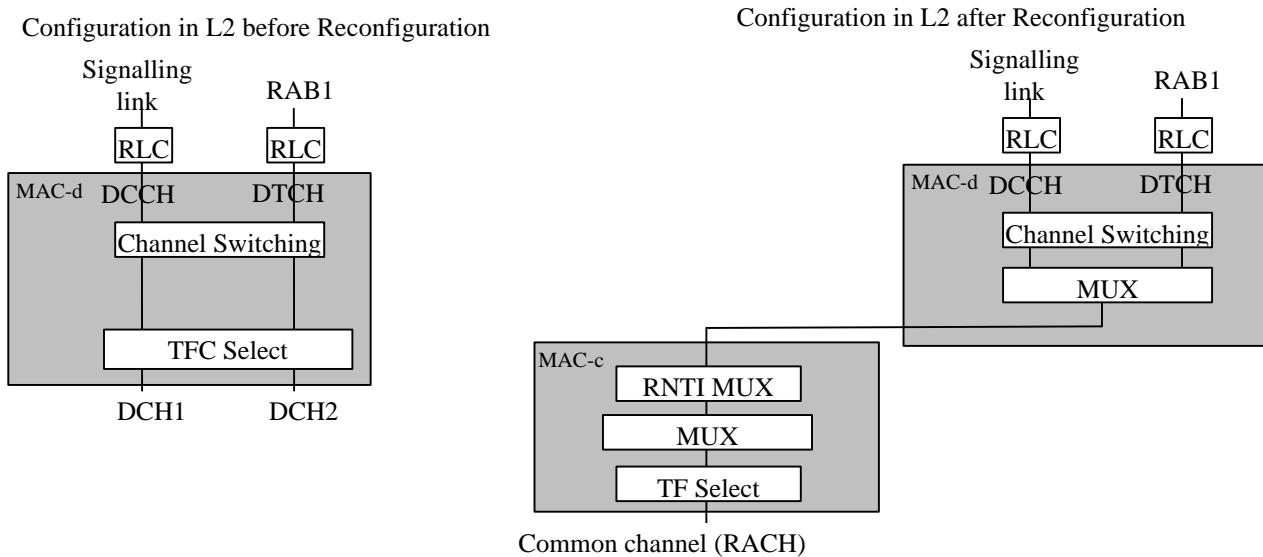

Figure 888 Configuration in the UTRAN UL before and after the Physical channel reconfiguration.

## 8.2.3 Examples of Transport Channel Reconfiguration

This RRC procedure is used to reconfigure the transport channel and the physical channels, and can by that also trigger Transport channel type switching.

Below, several examples of Transport channel reconfiguration are shown, triggered by different amount of UL or DL data.

### 8.2.3.1 Increased UL data, with no transport channel type switching

When a UE RLC buffer content increases above a certain threshold, a measurement report is sent to UTRAN. Depending on the overall load situation in the network the UTRAN could decide to increase the uplink capacity for a UE. Since every UE has its "own" code tree, there is no shortage of UL codes with a low spreading factor, and all UEs can have a low spreading factor code allocated.

Therefore, instead of channelization code assignment as used in the DL, load control in the UL is handled by the allowed transport formats and transport format combinations for each UE. To increase the throughput for a UE in the uplink, UTRAN could send a Transport channel reconfiguration or a TFC Control message.

Here a Transport channel reconfiguration is used. Although, the TFC Control procedure is believed to require less signalling it can only restrict or remove restrictions of the assigned transport format combinations and that may not always be enough. If a reconfiguration of the actual transport formats or transport format combinations is required, the Transport channel reconfiguration procedure must be used instead.

In the example below, the UE is allowed to send more data in the UL when on dedicated transport channel, although the common transport channel configuration is still the same. To make use of the new transport format combinations the physical channel must also be reconfigured to allow a lower spreading factor.

### 8.2.3.2 Decreased DL data, with switch from DCH/DCH to RACH/FACH

In the network the downlink traffic to a UE can be evaluated and the network can observe which transport format combinations that are used [Note: This is only one of many possible implementations of the network].

If a low amount of data is sent to the UE in the downlink and there is little traffic in the uplink, this could trigger a switch from a dedicated transport channel to a common transport channel. Depending on if the already defined RACH/FACH configuration is possible/preferred in the cell that the UE will be connected to after the switch, a Transport channel reconfiguration or a Physical channel reconfiguration procedure is used. In this example the UE has moved to cells with a different FACH or RACH configuration when using a dedicated transport channel, so a Transport channel reconfiguration procedure must be used.

When the UE do the switch from a dedicated transport to a common transport channel the RACH and FACH transport channels are reconfigured with new transport formats if the old configuration is not supported in the new cell. What physical common channel to be used is pointed out in the physical channel parameters.

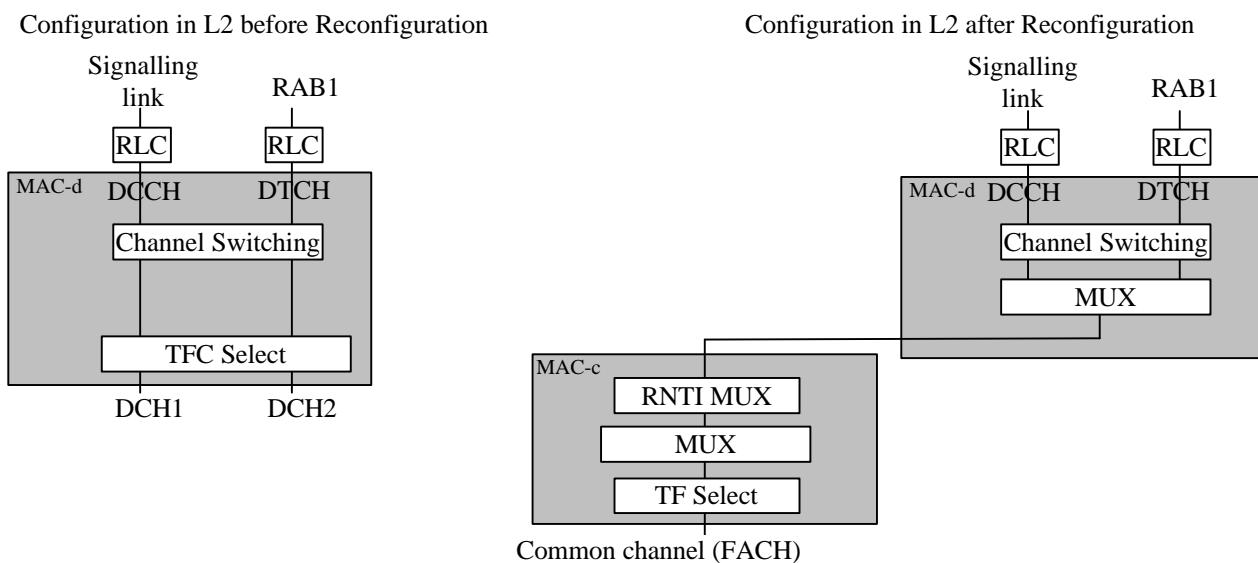

Figure 999 Configuration in the UTRAN DL before and after the Transport channel reconfiguration.

### 8.2.4 Example of RAB and Signalling link Reconfiguration

A Radio access bearer reconfiguration is here used to change how the MUX in MAC of logical channels belonging to different RABs is configured.

The RAB Reconfiguration message includes parameters for the new multiplexing configuration in MAC, and a reconfiguration of the Transport channel that both RABs will use. The old obsolete transport channel is also removed (here DCH3 is removed). All other parameters associated with the RABs are unchanged.

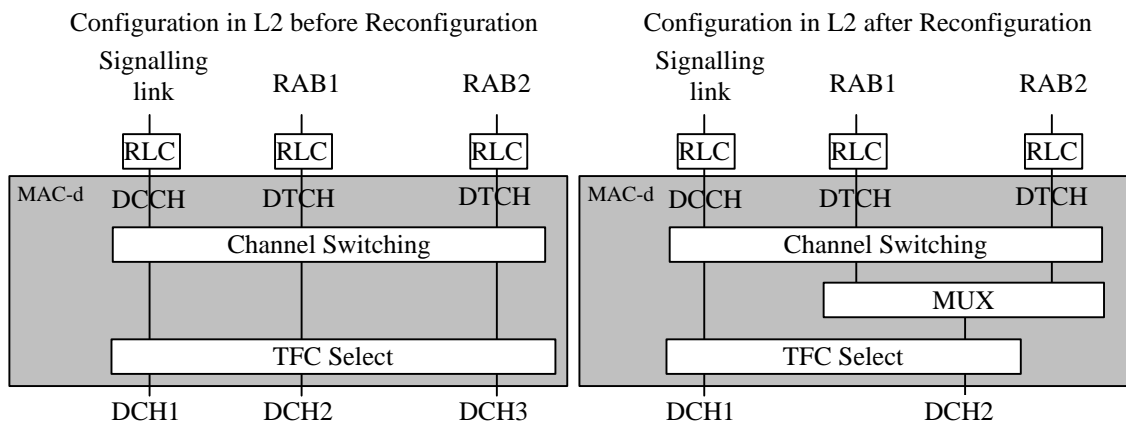

Figure 101010 Configuration in the UTRAN DL before and after the RAB reconfiguration.

### 8.3 RRC Elementary Procedures

The RRC Elementary Procedures are defined in section 6.3 of S2.03. Here some typical uses of these procedures are addressed.

#### Physical channel reconfiguration.

This procedure can be used when the first physical channel is assigned the UE enters the DCH/DCH state. When the last physical channel is released the UE leaves the DCH/DCH state and enters a state (and transport channel type) indicated by the network. A special case of using this procedure is to change the DL channelization code of a dedicated physical channel.

## 9. Dynamic Channel Allocation

### 9.1 DCA (FDD)

#### 9.1.1 Radio Resource Allocation Tasks (RACH/FACH and RACH+FAUSCH/FACH)

When there is either user or control data to transmit, a selection strategy determines whether the data should be transmitted on a common transport channel, or if a dedicated transport channel should be allocated. The selection should be dynamic and depend on traffic parameters (amount of data, packet burst frequency).

#### 9.1.2 Radio Resource Allocation tasks (DCH/DCH and DCH/DCH+DSCH)

For the DCH several physical channel allocations strategies may be applied; the allocations can be:

- Permanent: needing a DCH release message to be released;
- Based on time;
- Based on amount of data.

Resource allocation can be done separately for each packet burst by means of fast signaling on the DCH as specified in Section 5.5.1.1.13 in S2.03.

The configured set of combinations (i.e. transport format set for one transport channel) are monitored by the network to determine if the requirements on the QoS for a transport channel are respected. Otherwise the network initiates a reconfiguration of the transport format set (TFS) for that transport channel; this reconfiguration can be done during or in between data transmission.

Moreover the physical channel can be reconfigured for increasing or decreasing of the peak data rate.

The observed traffic volume, reported by the UE on the uplink, are used by the network in order to re-evaluate the current allocation of resources. This report contains e.g. the amount of data to be transmitted or the buffer status in the UE.

## 9.2 DCA (TDD)

### 9.2.1 Channel Allocation

*<not covered in ARIB TDD>*

For the UTRA-TDD mode a physical channel is characterised by a combination of its carrier frequency, time slot, and spreading code as explained in the chapter on the physical channel structure

Channel allocation covers both :

- resource allocation to cells (slow DCA)
- resource allocation to bearer services (fast DCA)

#### 9.2.1.1 Resource allocation to cells (slow DCA)

*<not covered in ARIB TDD>*

Channel allocation to cells follows the rules below:

- A reuse one cluster is used in the frequency domain. In terms of an interference-free DCA strategy a timeslot-to-cell assignment is performed, resulting in a time slot clustering. A reuse one cluster in frequency domain does not need frequency planning. If there is more than one carrier available for a single operator also other frequency reuse patterns >1 are possible.
- Any specific time slot within the TDD frame is available either for uplink or downlink transmission . UL/DL resources allocation is thus able to adapt itself to time varying asymmetric traffic.
- In order to accommodate the traffic load in the various cells the assignment of the timeslots (both UL and DL) to the cells is dynamically (on a coarse time scale) rearranged (slow DCA) taking into account that strongly interfering cells use different timeslots. Thus resources allocated to adjacent cells may also overlap depending on the interference situation.
- Due to idle periods between successive received and transmitted bursts, UEs can provide the network with interference measurements in time slots different from the one currently used. The availability of such information enables the operator to implement the DCA algorithm suited to the network.
- For instance, the prioritized assignment of time slots based on interference measurements results in a clustering in the time domain and in parallel takes into account the demands on locally different traffic loads within the network.

#### 9.2.1.2 Resource allocation to bearer services (fast DCA)

*<not covered in ARIB TDD>*

Fast channel allocation refers to the allocation of one or multiple physical channels to any bearer service Resource units (RUs) are acquired (and released) according to a cell-related preference list derived from the slow DCA scheme.

1. The following principles hold for fast channel allocation: The basic RU used for channel allocation is one code / timeslot / (frequency).
2. Multirate services are achieved by pooling of resource units. This can be made both in the code domain (pooling of multiple codes within one timeslot = **multicode** operation) and time domain (pooling of multiple timeslots within one frame = **multislot** operation). Additionally, any combination of both is possible. Simulation results reported in Appendix A, recommend that the DCA prefers code pooling , over time slot pooling, for UDD packet data; the use of code pooling in fact results in lower number of unsatisfied users.
3. Since the maximal number of codes per time slot in UL/DL depends on several physical circumstances like , channel characteristics, environments, etc. (see description of physical layer) and whether additional techniques to further enhance capacity are applied (for example smart antennas), the DCA algorithm has to be independent of this number. Additionally, time-hopping can be used to average inter-cell interference in case of low-medium bit rate users.



- 4. Channel allocation differentiates between RT and NRT bearer services:
  - RT services: Channels remain allocated for the whole duration the bearer service is established. The allocated resources may change because of a channel reallocation procedure (e.g. VBR).
  - NRT services: Channels are allocated for the period of the transmission of a dedicated data packet only. Channel allocation is performed using 'best effort strategy', i.e. resources available for NRT services are distributed to all admitted NRT services with pending transmission requests. The number of channels allocated for any NRT service is variable and depends at least on the number of current available resources and the number of NRT services attempting for packet transmission simultaneously. Additionally, prioritisation of admitted NRT services is possible.
- 5. Channel reallocation procedures (intra-cell handover) can be triggered for many reasons:
  - To cope with varying interference conditions.
  - In case of high rate RT services (i.e. services requiring multiple resource units) a 'channel reshuffling procedure' is required to prevent a fragmentation of the allocated codes over to many timeslots. This is achieved by freeing the least loaded timeslots (timeslots with minimum used codes) by performing a channel reallocation procedure.
  - When using smart antennas, channel reallocation is useful to keep spatially separated the different users in the same timeslot.

## 9.2.2 Measurements Reports from UE to the UTRAN

While in active mode the DCA needs measurements for the reshuffling procedure (intra-cell handover). The specification of the measurements to be performed is contained in Section 7.4 in [10]. In this section the relevant measurement reports are presented:

- Pathloss of a sub-set of cells (pathloss is quantized in  $N_{PL}$  [e.g. 128] intervals ; [max. number of cells is 30].
- Inter-cell interference measurements of all DL time slots requested by the UTRAN (interference is quantized in  $N_{ICI}$  [e.g. 32] intervals, due to asymmetry up to 14 time slots are possible)
- BER of serving link (quantized in  $N_{BER}$  [e.g. 16] intervals)
- Transmission power of the UE on serving link (separated in  $N_{TX}$  [e.g. 64] intervals)
- DTX flag link
- ffs

Further measurements and reports can be requested by the UTRAN.

The RLC informs the DCA about transmission errors. The interaction between DCA and RLC depends on the RLC operation mode. Details are for further study.

---

## 10. Power Management

---

## 11. Radio Link Surveillance

---

## 12. Appendix A

## 12.1 Simulation environment

The presented simulations are performed in the following environments and services according to the requirements in the following documents:

- ETSI TR 101 112, Selection procedures for the choice of radio transmission technologies of the Universal Mobile Telecommunications System UMTS (UMTS 30.03), version 3.2.0, April 1998.
- Seppo Hämäläinen, Peter Slanina, Magnus Hartman, Antti Lappeteläinen, Harri Holma, Oscar Salonaho, A Novel Interface Between Link and System Level Simulations, Acts Mobile Communications Summit '97, pp. 599-604, Aalborg/Denmark, Oct 7-10, 1997.

Absolute capacities [kbit/s/MHz/cell] were published in:

- ETSI Tdoc SMG2 306/98, UTRA TDD Link Level and System Level Simulation Results for ITU Submission, Source: Siemens, Helsinki, Sep 8-11, 1998.

1. Macro (Vehicular) environment for the UDD 144 kbit/s service.
2. Micro (Outdoor-to-Indoor Pedestrian) environment for the UDD 384 kbit/s service.

## 12.2 Results

The relative load of the cell is used for the abscissa (horizontal axis) in all of the plots. Here, a relative load of 100% refers to the maximum cell load obtainable with code-pooling under the ETSI unsatisfied user criterion (in accordance with ETSI TR 101 112). Vertically, the percentage of unsatisfied users is shown.

### 12.2.1 Macro UDD 144

In the Macro environment the UDD 144 service is simulated with Hybrid ARQ Type II-III using an adaptive code-rate between 1 and  $\frac{1}{2}$ .

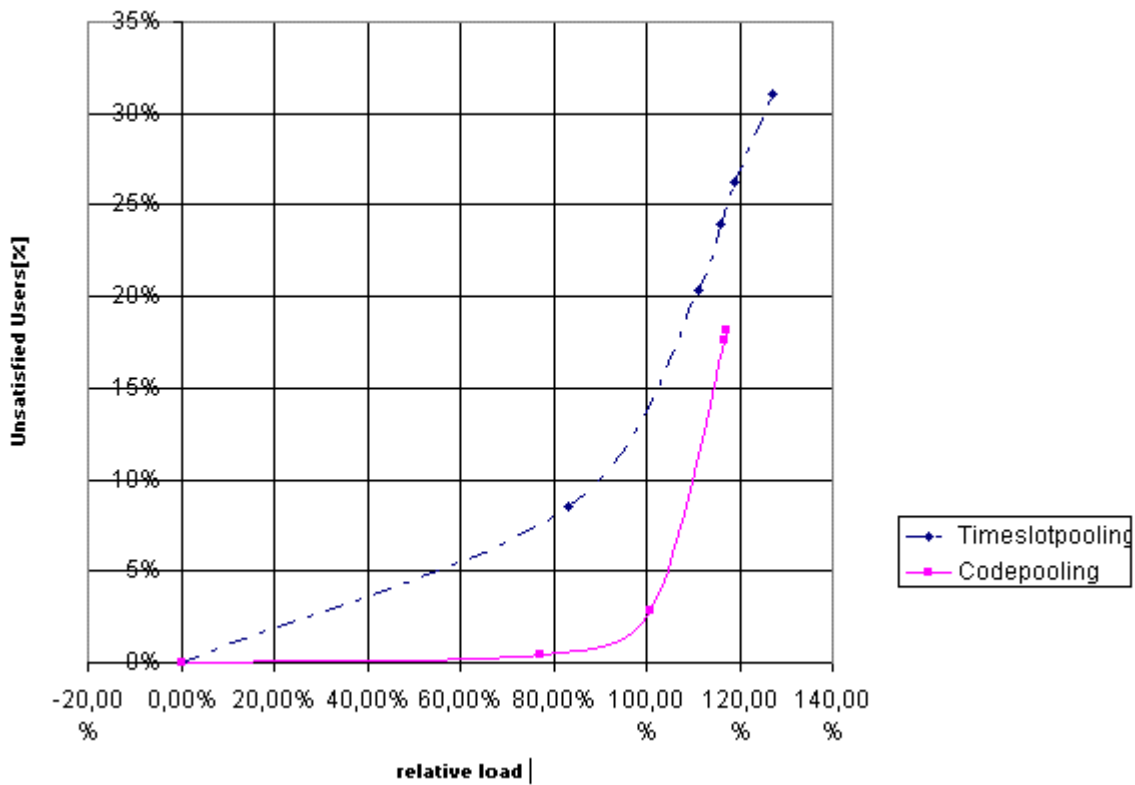

## 12.2.2 Micro UDD 384

In the Micro environment the UDD 384 service is simulated with Hybrid ARQ I using code-rates 1 and 2/3.

### 12.2.2.1 Code rate 1

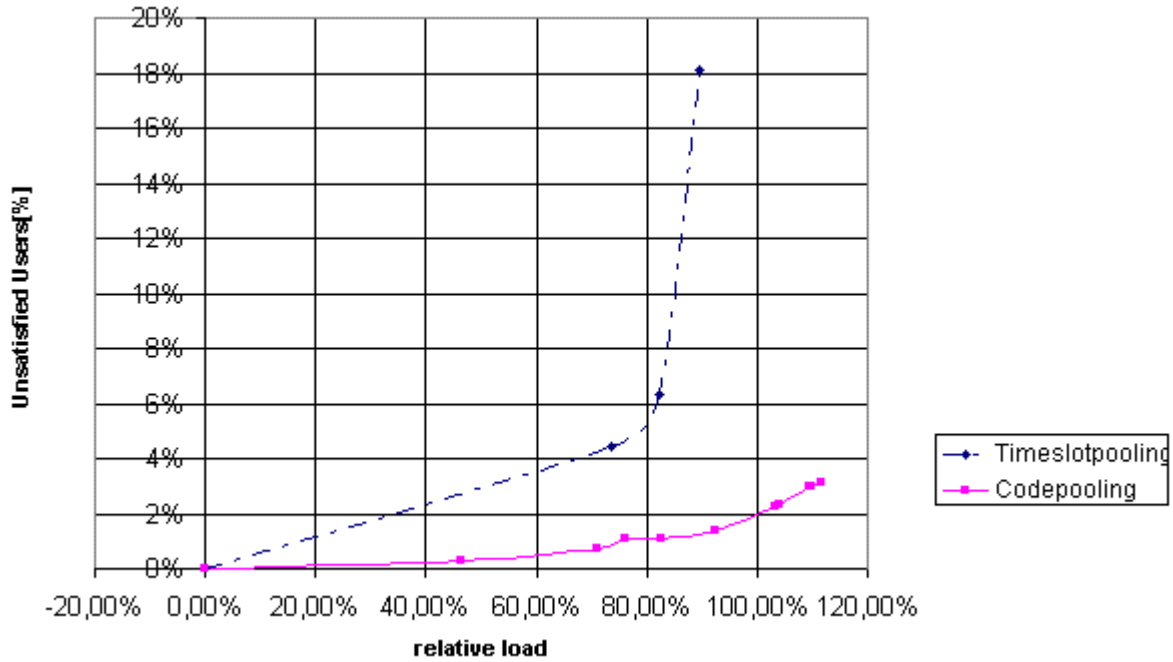

### 12.2.2.2 Code rate 2/3

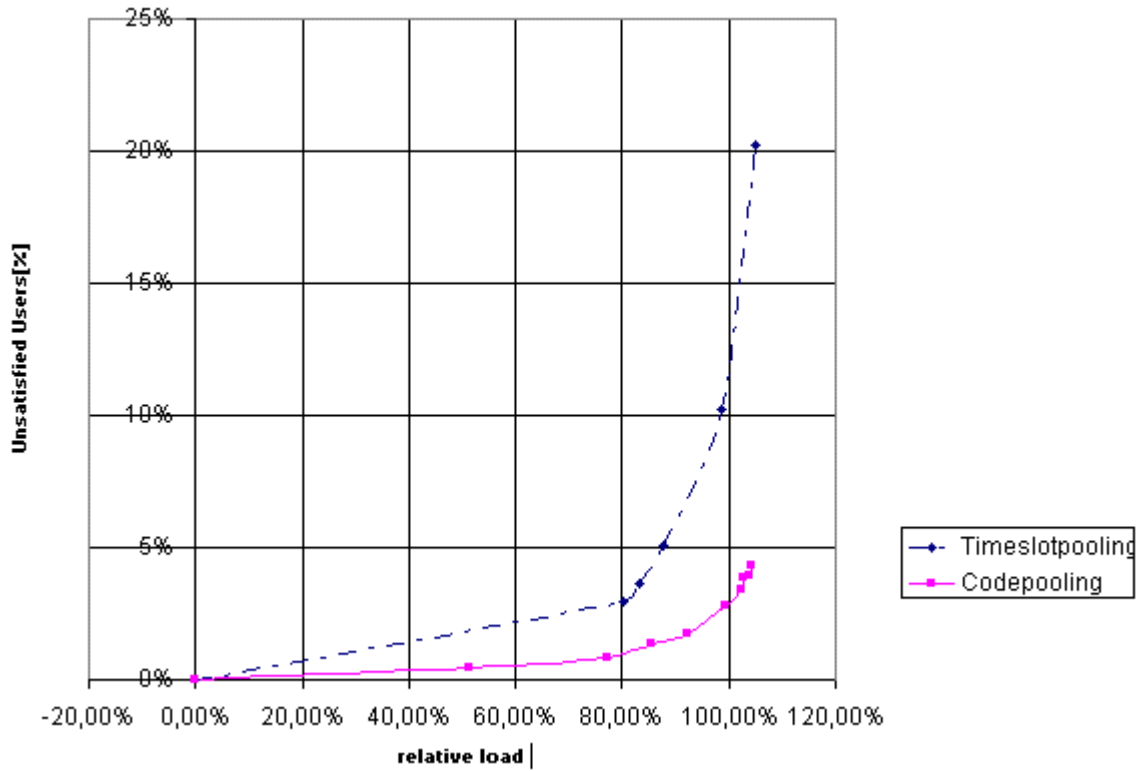

## 12.3 Conclusions

With both Hybrid ARQ I and Hybrid ARQ II code pooling performs better than time slot pooling. This is explained as follows: Code-pooling performs better in conjunction with the initial transmission of Hybrid ARQ Type II-III. Timeslot pooling suffers from a high probability of low CIR in at least one of the used timeslots of the PDU. This leads to a high initial transmission failure probability because the initial transmission is sent almost uncoded. When code-pooling is applied, the whole PDU depends on the same interference level on all codes: the probabilities of low CIR on each spreading-code within the same timeslot are strongly coupled.

- The probability of PDU transmission failure for code-pooling is approximately the same as the probability of low CIR in a single timeslot.
- The probability of PDU transmission failure for timeslot-pooling is approximately the same as the probability of low CIR in at least one of the used timeslots.

This advantage of code-pooling results in lower numbers of unsatisfied users. These results clearly recommend that the DCA prefers code pooling over timeslot pooling for UDD packet data in TDD mode.

---

## 13. History

Document history		
Date	Version	Comment
<u>May 1999</u>	<u>0.1.2</u>	<u>The new numbering was changed from TR R2.02 to TR R25.922 in accordance to RAN indication.</u>  <u>The new text developed on the basis of the outcome of the last WG2 meeting in Yokohama was included and outlined by revision marks. There was no comment circulated on the mail reflector; therefore, the same document was submitted to the next WG2 meeting for discussion.</u>
April 1999	0.1.1	Inclusion of the input contributions 99/270, 99/246, 99/251. Approved by WG2. This document was submitted to TSG RAN and noted as version 0.1.1
April 1999	0.1.0	Document approved at Yokohama meeting
April 1999	0.0.3	Document reviewed after the comments provided during the meeting of Yokohama,
April 1999	0.0.2	Different parts from various documents of TSG RAN were included in the first draft version of TR R2.02.

March 1999	0.0.1	Document was created. A Scope and an index were added on the basis of td R2-99-182
Rapporteur for 3GPP TSG RAN WG2 R2.02 is:		
CSELT		
Daniele Franceschini		Nicola Pio Magnani
Tel.: +39 011 228 5203		Tel.: +39 011 228 7089
Fax: .... +39 011 228 7613		Fax: +39 011 2287613
e-mail: <a href="mailto:daniele.franceschini@cse.lt">daniele.franceschini@cse.lt</a>		e-mail: <a href="mailto:nicola.magnani@cse.lt">nicola.magnani@cse.lt</a>
This document is written in Microsoft Word Version 97 SR-1 and saved in Rich Text Format.		