

TSG-RAN Working Group 2 (Radio layer 2 and Radio layer 3)
Berlin, Germany 25th to 28th May 1999

TSGR2#4(99)357

Agenda Item: 4.2

Source: Editor

Title: TS 25.321 V2.0.1 MAC protocol specification

Document for: Approval

TS 25.321 V2.0.1 (1999-05)

Technical Specification

**3rd Generation Partnership Project (3GPP);
Technical Specification Group (TSG) RAN;
Working Group 2 (WG2);**

MAC protocol specification



Reference

<Workitem> (<Shortfilename>.PDF)

Keywords

<keyword[, keyword]>

3GPP

Postal address

Office address

Internet

secretariat@3gpp.org
Individual copies of this deliverable
can be downloaded from
<http://www.3gpp.org>

Copyright Notification

No part may be reproduced except as authorized by written permission.
The copyright and the foregoing restriction extend to reproduction in all media.

©
All rights reserved.

Contents

INTELLECTUAL PROPERTY RIGHTS	7
FOREWORD	7
1. SCOPE	8
2. REFERENCES	9
3. DEFINITIONS, ABBREVIATIONS AND SYMBOLS	10
3.1 DEFINITIONS	10
3.2 ABBREVIATIONS	9
3.3 SYMBOLS	11
4. GENERAL	12
4.1 OBJECTIVE	12
4.2 OVERVIEW ON MAC ARCHITECTURE	12
4.3 CHANNEL STRUCTURE	19
4.3.1 <i>Transport channels</i>	19
4.3.2 <i>Logical Channels</i>	19
4.3.2.1 <i>Logical channel structure</i>	21
4.3.2.2 <i>Control Channels</i>	21
4.3.2.3 <i>Traffic Channels</i>	21
4.3.3 <i>Mapping between logical channels and transport channels</i>	21
5. SERVICES PROVIDED TO UPPER LAYERS	22
5.1 DESCRIPTION OF SERVICES PROVIDED TO UPPER LAYERS	22
6. FUNCTIONS	22
6.1 DESCRIPTION OF THE MAC FUNCTIONS	22
6.2 RELATION BETWEEN MAC FUNCTIONS / TRANSPORT CHANNELS AND UE	23
6.2.1 <i>Relation between MAC Functions and Transport Channels</i>	23
6.2.2 <i>Relation of UE MAC functions corresponding to the Transport Channel MAC Functions and Transport Channels</i>	24
24	
7. SERVICES EXPECTED FROM PHYSICAL LAYER	24
8. ELEMENTS FOR LAYER-TO-LAYER COMMUNICATION	25
8.1 PRIMITIVES BETWEEN LAYERS 1 AND 2	25
8.2 PRIMITIVES BETWEEN MAC AND RLC	25
8.2.1 <i>Primitives</i>	25
8.2.2 <i>Parameters</i>	25
8.3 PRIMITIVES BETWEEN MAC AND RRC	26
8.3.1 <i>Primitives</i>	26
8.3.2 <i>Parameters</i>	26
9. ELEMENTS FOR PEER-TO-PEER COMMUNICATION	27
9.1 PROTOCOL DATA UNITS	27
9.1.1 <i>MAC Data PDU</i>	27
9.1.2 <i>MAC Control PDU</i>	27
9.1.3 <i>MAC messages for peer to peer communication</i>	26
9.2 FORMATS AND PARAMETERS	28
9.2.1 <i>MAC Data PDU: Parameters of the MAC header</i>	28
9.2.2 <i>Control PDUs</i>	30
9.2.3 <i>Format of MAC messages for peer to peer communication</i>	30
9.3 PROTOCOL STATES	30

9.4	STATE VARIABLES	30
9.5	TIMERS.....	30
9.6	PROTOCOL PARAMETERS	30
9.7	SPECIFIC FUNCTIONS	30
10.	HANDLING OF UNKNOWN, UNFORESEEN AND ERRONEOUS PROTOCOL DATA.....	30
11.	ELEMENTARY PROCEDURES	31
11.1	DYNAMIC RADIO BEARER CONTROL IN UE.....	31
12.	HISTORY	32
13.	APPENDICES: EXAMPLES OF OPERATION.....	33
14.	ANNEX 1: MAC FUNCTIONS.....	33
14.1	GENERAL FUNCTIONS.....	33
14.2	COMMON CHANNEL RELATED FUNCTIONS	34
14.2.1	<i>Control of BCH.....</i>	<i>34</i>
14.2.2	<i>Control of PCH.....</i>	<i>34</i>
14.2.3	<i>Control of FACH</i>	<i>34</i>
14.2.4	<i>Control of RACH.....</i>	<i>35</i>
14.3	CONTROL OF DCH.....	36
14.3.1	<i>Overview.....</i>	<i>36</i>
14.3.2	<i>Priority handling between data flows of one MS.....</i>	<i>36</i>
14.4	OTHER FUNCTIONS	37
14.4.1	<i>Selection of appropriate transport format</i>	<i>37</i>
14.4.2	<i>Traffic volume measurement.....</i>	<i>37</i>
14.4.3	<i>Channel type switching execution</i>	<i>37</i>
14.4.4	<i>Priority handling between data flows of different users by means of scheduling</i>	<i>37</i>
14.4.5	<i>Ciphering</i>	<i>38</i>
15.	ANNEX 2: MAC PROCEDURES / ELEMENTARY PROCEDURES	38
15.1	RANDOM ACCESS PROCEDURE	38
15.2	CHANNEL TYPE SWITCHING PROCEDURE	40
16.	ANNEX 3: MAC PARAMETERS.....	41
16.1	RNTI (RADIO NETWORK TEMPORARY IDENTIFIER)	41
16.2	LID (LOGICAL CHANNEL IDENTIFIER).....	41
16.3	NR (THE NUMBER OF RNTI)	41
16.4	RNTI FIELD.....	41

Intellectual Property Rights

IPRs essential or potentially essential to the present deliverable may have been declared to 3GPP and/or its organizational partners. The information pertaining to these essential IPRs, if any, is publicly available for 3GPP **members and non-members, free of charge**. This can be found in the latest version of the 3GPP Technical Report: [tbd.].

Pursuant to the 3GPP Interim IPR Policy, no investigation, including IPR searches, has been carried out by 3GPP. No guarantee can be given as to the existence of other IPRs not referenced in the [tbd.], which are, or may be, or may become, essential to the present document.

Note: The content has to be reviewed according to the 3GPP IPR rules.

Foreword

This Technical Specification has been produced by the 3GPP.

The contents of the present document are subject to continuing work within the TSG and may change following formal TSG approval. Should the TSG modify the contents of this TS, it will be re-released by the TSG with an identifying change of release date and an increase in version number as follows:

Version 3.y.z

where:

- x the first digit:
 - 1 presented to TSG for information;
 - 2 presented to TSG for approval;
 - 3 Indicates TSG approved document under change control.
- y the second digit is incremented for all changes of substance, i.e. technical enhancements, corrections, updates, etc.
- z the third digit is incremented when editorial only changes have been incorporated in the specification;

1. Scope

The scope of this description is the specification of the MAC protocol.

The following lists the contents for the specification of the MAC protocol:

1. list of procedures
2. logical flow diagrams for normal procedures
3. logical description of message
4. principles for error handling
5. some exceptional procedures which are felt criteria
6. It should, as far as possible, have the same format and outline as the final specification
7. exact message format
8. all scenarios

Editors note: The list has to be reviewed.

2. References

The following documents contain provisions which, through reference in this text, constitute provisions of the present document.

- References are either specific (identified by date of publication, edition number, version number, etc.) or non-specific.
- For a specific reference, subsequent revisions do not apply.
- For a non-specific reference, the latest version applies.
- A non-specific reference to an TS shall also be taken to refer to later versions published as an EN with the same number.

[1] 3GPP Homepage: www.3gpp.org

[2] [TS25.301](#), Radio Interface Protocol Architecture

[3] [TS25.302](#), Layer 1; General requirements

[4] [TS25.303](#), UE States and Procedures in Connected Mode

[5] [TS25.304](#), Description of procedures in idle Mode

[6] [TS25.322](#), Description of RLC protocol

[7] [TS25.331](#), Description of RRC protocol

[8] [TS25.39140](#), Description of principles for error handling and message description

[9] ETSI UMTS 25.XX: "Vocabulary for the UTRAN"

3. Definitions, abbreviations and symbols

3.1 Definitions

See [9] for a definition of fundamental concepts and vocabulary.

3.2 Abbreviations

ARQ	Automatic Repeat Request
ASC	Access Service Class
BCCCH	Broadcast Control Channel
BCH	Broadcast Channel
C-	Control-
CC	Call Control
CCCH	Common Control Channel
CCTrCH	Coded Composite Transport Channel
CN	Core Network
CRC	Cyclic Redundancy Check
DC	Dedicated Control (SAP)
DCA	Dynamic Channel Allocation
DCCH	Dedicated Control Channel
DCH	Dedicated Channel
DL	Downlink
DRNC	Drift Radio Network Controller
DSCH	Downlink Shared Channel
DTCH	Dedicated Traffic Channel
FACH	Forward Link Access Channel
FAUSCH	Fast Uplink Signalling Channel
FCS	Frame Check Sequence
FDD	Frequency Division Duplex
GC	General Control (SAP)
HO	Handover
ITU	International Telecommunication Union
kbps	kilo-bits per second
L1	Layer 1 (physical layer)
L2	Layer 2 (data link layer)
L3	Layer 3 (network layer)
LAC	Link Access Control
LAI	Location Area Identity
MAC	Medium Access Control
MM	Mobility Management
Nt	Notification (SAP)
OCCCH	ODMA Common Control Channel
ODCCH	ODMA Dedicated Control Channel
ODCH	ODMA Dedicated Channel
ODMA	Opportunity Driven Multiple Access
ORACH	ODMA Random Access Channel
ODTCH	ODMA Dedicated Traffic Channel
PCCH	Paging Control Channel
PCH	Paging Channel
PDU	Protocol Data Unit
PHY	Physical layer
PhyCH	Physical Channels
RACH	Random Access Channel
RLC	Radio Link Control
RNC	Radio Network Controller
RNS	Radio Network Subsystem

RNTI	Radio Network Temporary Identity
RRC	Radio Resource Control
SAP	Service Access Point
SCCH	Synchronization Control Channel
SCH	Synchronization Channel
SDU	Service Data Unit
SRNC	Serving Radio Network Controller
SRNS	Serving Radio Network Subsystem
TDD	Time Division Duplex
TFCI	Transport Format Combination Indicator
TFI	Transport Format Indicator
TMSI	Temporary Mobile Subscriber Identity
TPC	Transmit Power Control
U-	User-
UE	User Equipment
UE _R	User Equipment with ODMA relay operation enabled
UL	Uplink
UMTS	Universal Mobile Telecommunications System
URA	UTRAN Registration Area
USCH	Uplink Shared Channel
UTRA	UMTS Terrestrial Radio Access
UTRAN	UMTS Terrestrial Radio Access Network

3.3 Symbols

4. General

4.1 Objective

4.2 Overview on MAC architecture

The following provides an overview of a common MAC architecture that encompasses both UMTS-FDD and UMTS-TDD. There are differences of detail between the two systems but their architectures are sufficiently similar for a common overview to be adopted. Followed by section 4.2.1 MAC entities, where the different MAC entities are summarised, the sections 4.2.2-4 contain a more detailed description of the MAC architecture.

Note: The contents have to be reviewed, changes depend on further contributions

4.2.1 MAC Entities

The diagrams that describe the MAC architecture are constructed from MAC entities. The entities are assigned the following names. The functions completed by the entities are different in the UE from those completed in the UTRAN:

- MAC-b, which identifies the MAC entity that handles the broadcast channel (BCH). There is one MAC-b entity in each UE and one MAC-b in the UTRAN for each cell.
Note: The separation in two different BCCH is ffs, the control SAP may be split accordingly
- MAC-p, which identifies the MAC entity that handles the paging channel (PCH). There is one MAC-p entity in each UE and one MAC-p in the UTRAN for each cell.
- MAC-c, which identifies the MAC entity that handles the forward access channel (FACH) and the random access channel (RACH). There is one MAC-c entity in each UE and one in the UTRAN for each cell.
- MAC-d, denotes the MAC entity that is responsible for handling of dedicated logical channels and dedicated transport channels (DCH) allocated to a UE. There is one MAC-d entity in the UE and one MAC-d entity in the UTRAN for each UE. Note: *When a UE is allocated resources for exclusive use by the bearers that it supports the MAC-d entities dynamically share the resources between the bearers and are responsible for selecting the TFI/TFCI that is to be used in each transmission time interval.*
- MAC-sh, denotes the MAC entity that handles downlink shared channels (DSCH) for both FDD and TDD and uplink shared channels (USCH) for TDD . There is one MAC-sh entity in each UE that is using a DSCH and a USCH for TDD operation and one MAC-sh entity in the UTRAN for each cell that contains a DSCH and a USCH for TDD operation.
- MAC-sy, identifies the MAC entity used in TDD operation to handle the information received on the synchronisation channel SCH

According to the RRC functions the RRC is generally in control of the internal configuration of the MAC.

4.2.2 MAC-b , MAC-p and MAC-sy

The following diagram illustrates the connectivity of the MAC-b , MAC-p and MAC-sy entities in a UE and in each cell of the UTRAN:

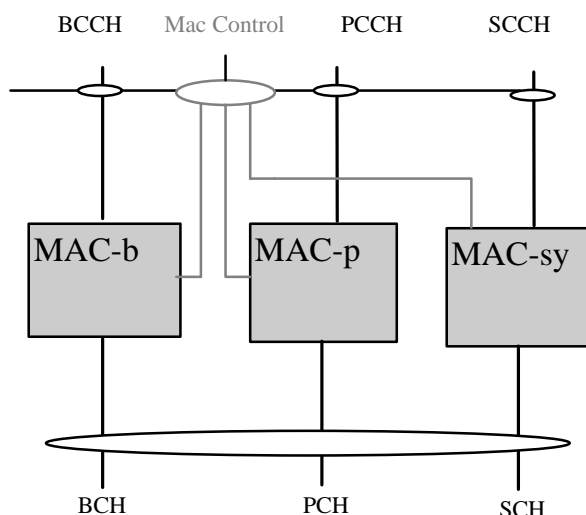

Figure 4.2.2.1 UE side and UTRAN side architecture (BCCH ,PCCH and SCCH)

MAC-b, MAC-p and MAC-sy represents SCH, BCH and PCH control entities, which are cell-specific MAC entities in the UTRAN. In the UE side there is one SCH, BCH and PCH control entity per UE. The SCH control entity handles synchronisation channels for the TDD mode. The details of this entity are left for further study. The MAC Control SAP is used to transfer Control information to each MAC entity.

4.2.3 Traffic Related Architecture - UE Side

Figure 4.2.3.1 illustrates the connectivity of MAC entities. The figure shows a MAC-d servicing the needs of several DTCH mapping them to a number of DCH. A MAC-sh controls access to a common transport channel. It is noted that because the MAC-sh provides additional capacity then it communicates only with the MAC-d rather than the DTCH directly. The MAC-c, which interfaces with the FACH and RACH common signalling channels, is connected with the MAC-d for transfer of data and RNTI. The MAC Control SAP is used to transfer Control information to each MAC entity. In the TDD implementation the MAC-sh transfers data from the DSCH to the MAC-d and from the MAC-d to the USCH under control of the FACH.

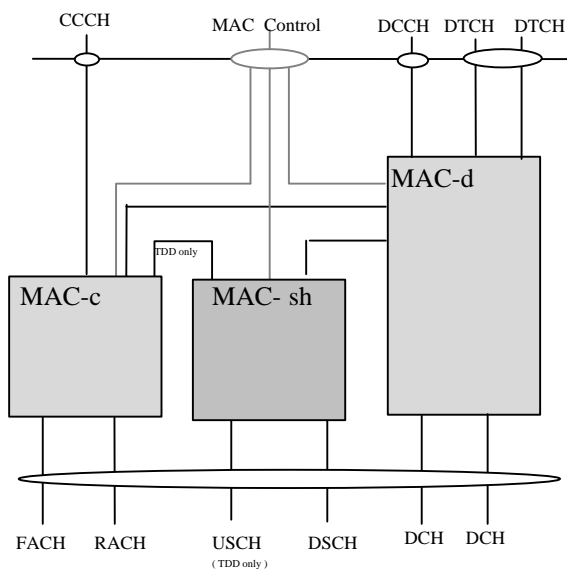

Figure 4.2.3.1 UE side MAC architecture

Figure 4.2.3.2 shows the UE side MAC-c entity. The following functionality is covered:

- The C/D MUX box represents the insertion and detection of the field in the MAC header, indicating whether a common or dedicated logical channel is used.
- The c-RNTI field in the MAC header is used to distinguish between UEs.
- In the uplink, the possibility of transport format selection exists.
- Selection of Access Service Classes (ASC) for RACH, details on definition of ASC and the relation to the RACH retransmission algorithm are ffs.

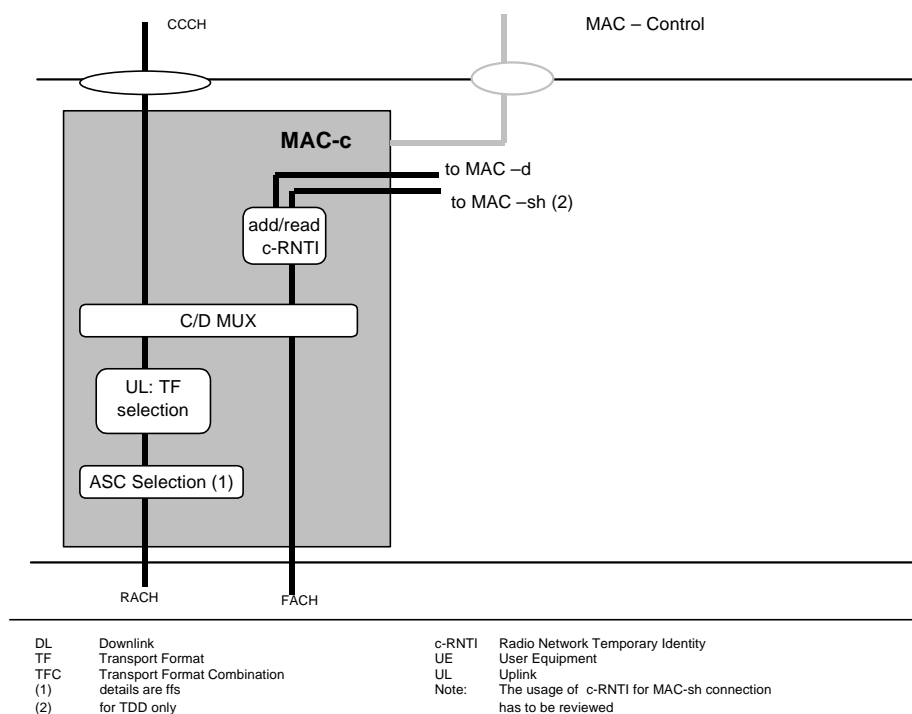

Figure 4.2.3.2. UE side MAC architecture / MAC-c details

Figure 4.2.3.3 shows the UE side MAC-d entity. The following functionality is covered:

- Dynamic transport channel type switching is performed by this entity, based on decision taken by RRC.
- The C/T MUX box is used when multiplexing of several dedicated logical channels onto one transport channel is used.
- The MAC-d entity using common channels is connected to a MAC-c entity that handles the scheduling of the common channels to which the UE is assigned.
- The MAC-d entity using downlink shared channel is connected to a MAC-sh entity that handles the reception of data received on the shared channels to which the UE is assigned.
- In the uplink, transport format combination selection (out of the RRC assigned transport format combination set) is performed to prioritise transport channels.
- FAUSCH Handling indicates the function in the MAC-d supports the FAUSCH, details are ffs

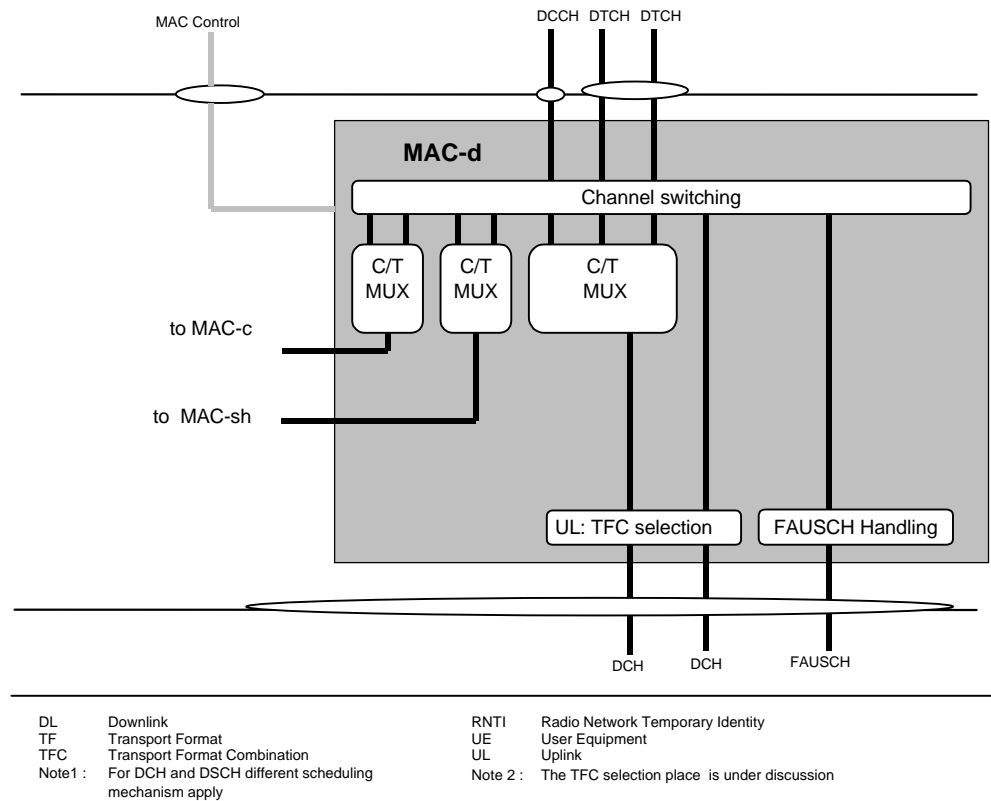

Figure 4.2.3.3. UE side MAC architecture / MAC-d details

Figure 4.2.3.4 shows the UE side MAC-sh entity. The following functionality is covered:

- RNTI is used on the DSCH Control Channel to identify the UE. Additionally, some timing / physical information is needed to tell the UE when to listen to DSCH.
- Multiplexing is used to transmit the received information on DSCH and DSCH Control Channel to the Mac-d, for TDD the multiplexing is used to transfer data from MAC-d to USCH and receives control information for shared operation from MAC-c.

The RLC has to provide RLC-PDU's to the MAC which fits into the available transport blocks on the transport channels respectively.

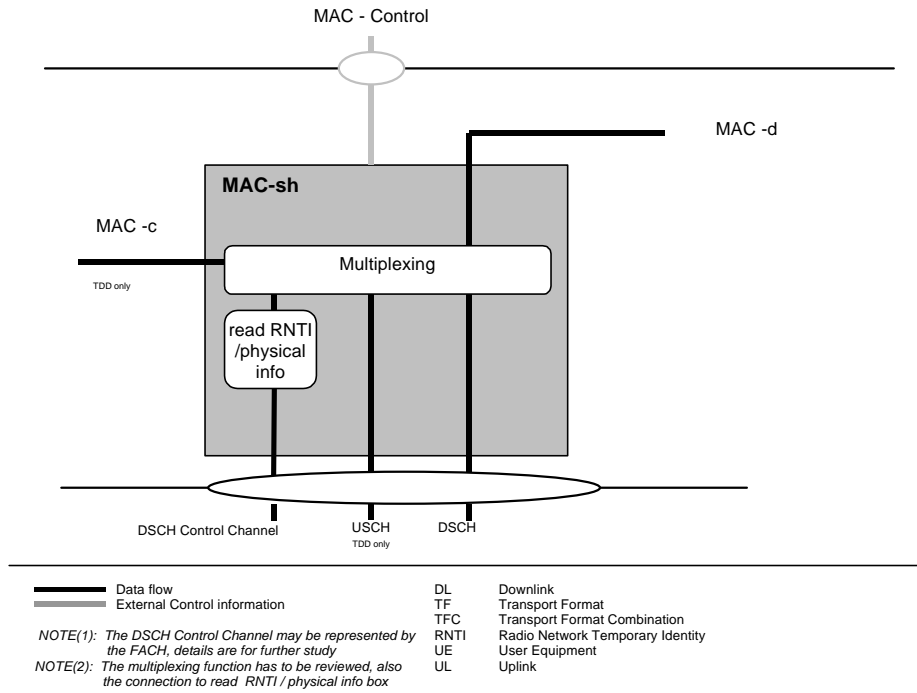

Figure 4.2.3.4. UE side MAC architecture / MAC-sh details

4.2.4. Traffic Related Architecture - UTRAN Side

Figure 4.2.4.1 illustrates the connectivity between the MAC entities from the UTRAN side. It is similar to the UE case with the exception that there will be one MAC-d for each UE and each UE (MAC-d) that is associated with a particular cell may be associated with that cell's MAC-sh. MAC-c and MAC-sh are located in the controlling RNC while MAC-d is located in the serving RNC. The MAC Control SAP is used to transfer Control information to each MAC entity belongs to one UE.

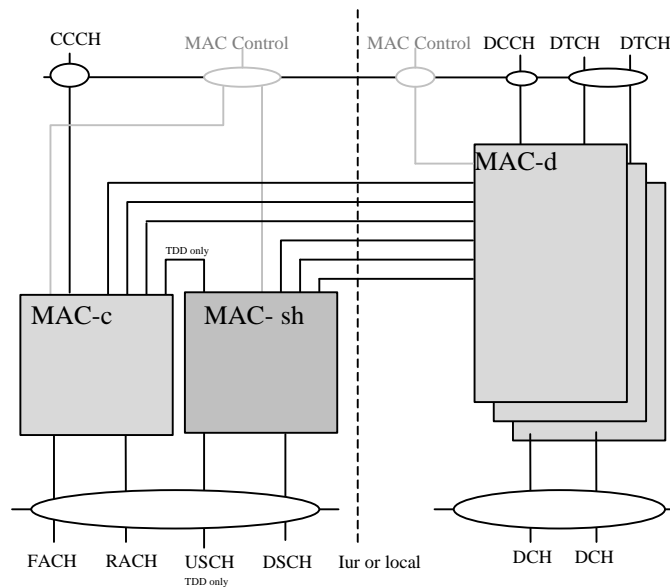

Figure 4.2.4.1: UTRAN side MAC architecture

Figure 4.2.4.2 shows the UTRAN side MAC-c entity. The following functionality is covered:

- The C/D box represents the insertion and detection of the field in the MAC header, indicating whether a common or dedicated logical channel is used.
- For dedicated type logical channels, the c-RNTI field in the MAC header is used to distinguish between UEs.
- In the downlink, transport format selection might be done if FACH is variable rate.

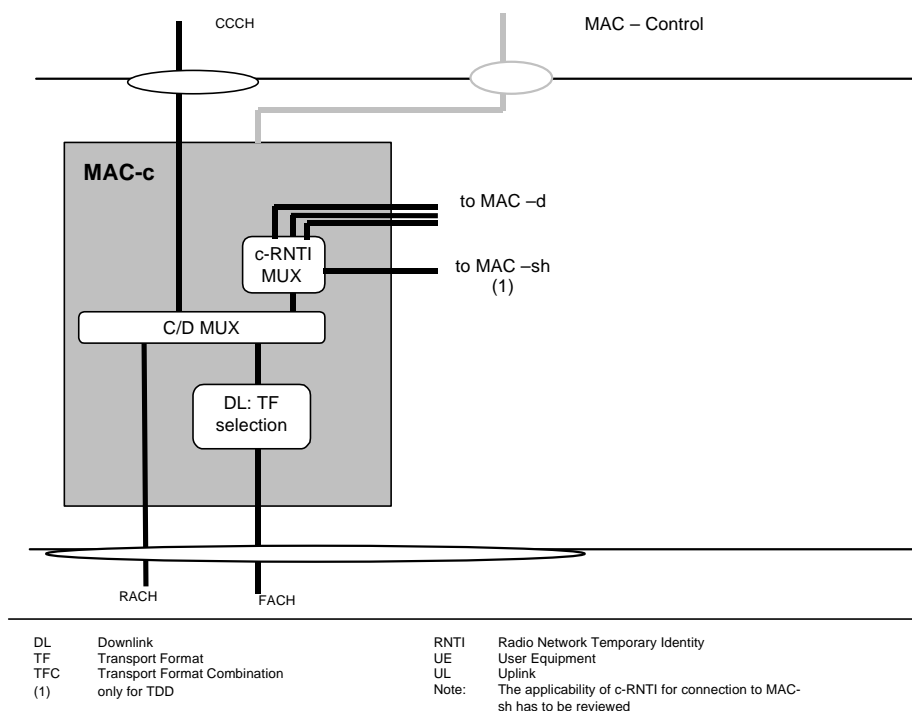

Figure 4.2.4.2 UTRAN side MAC architecture / MAC-c details

Figure 4.2.4.3 shows the UTRAN side MAC-d entity. The following functionality is covered:

- Dynamic transport channel type switching is performed by this entity, based on decision taken by RRC.
- The C/T MUX box is used when multiplexing of several dedicated logical channels onto one transport channel is used.
- Each MAC-d entity using common channels is connected to a MAC-c entity that handles the scheduling of the common channels to which the UE is assigned.
- Each MAC-d entity using downlink shared channel is connected to a MAC-sh entity that handles the shared channels to which the UE is assigned and indicates the level of priority of each PDU to MAC-sh and to MAC-c.
- In the downlink, scheduling and priority handling of transport channels is performed within the allowed transport format combinations of the TFCS assigned by the RRC. This function supports the TFCI insertion in Node B .
- FAUSCH Handling indicates the function in the MAC-d supports the FAUSCH, details are ffs.

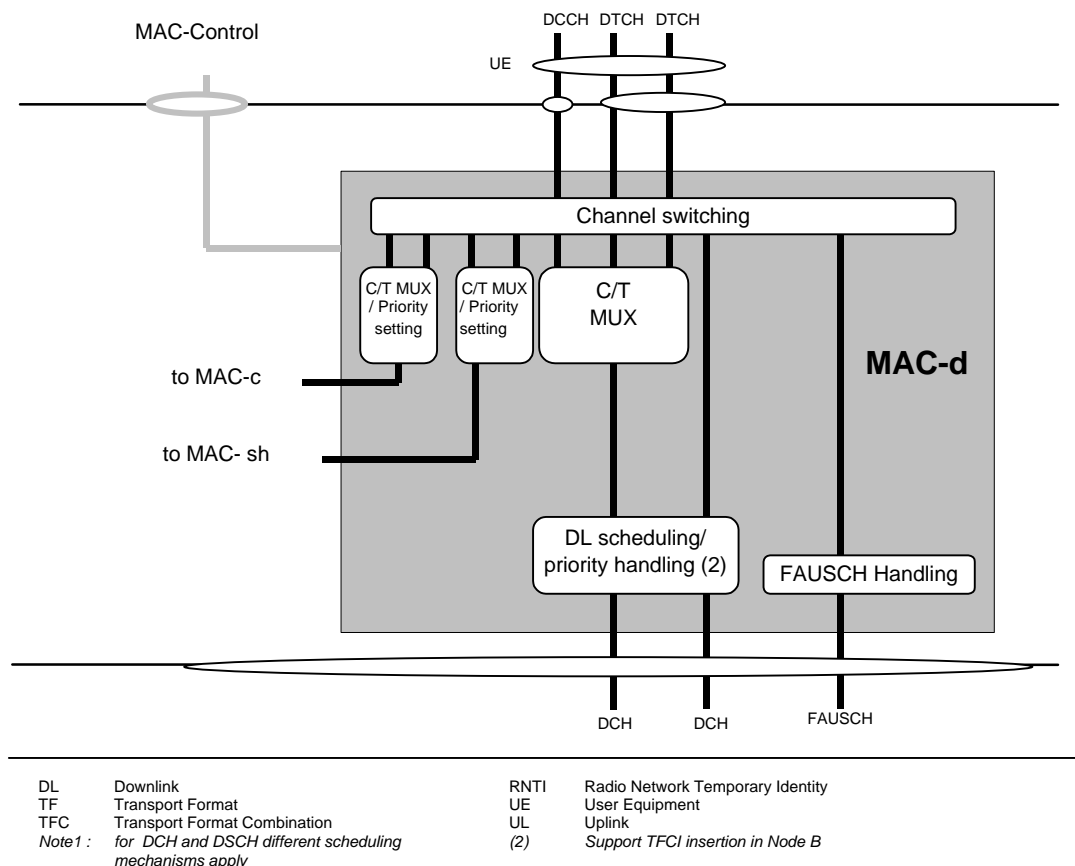

Figure 4.2.4.3 UTRAN side MAC architecture / MAC-d details

Figure 4.2.4.4 shows the UTRAN side MAC-sh entity. The following functionality is covered:

- A specific UE ID is needed when using the DSCH Control Channel to identify the UE on the DSCH. This specific UE ID may be optimised for DSCH and will be allocated when a RAB is mapped onto a DSCH. Additionally, some timing information is needed to tell the UE when to listen to DSCH.
- The scheduling /priority handling box in MAC-sh shares the DSCH resources between the UEs and between data flows according to their priority. For TDD operation the demultiplex function is used to support the USCH and the connection to the MAC-c.
- DL code allocation is used to indicate the code used on the DSCH and the appropriate Transport format on the DSCH.

The RLC has to provide RLC-PDU's to the MAC which fits into the available transport blocks on the transport channels respectively.

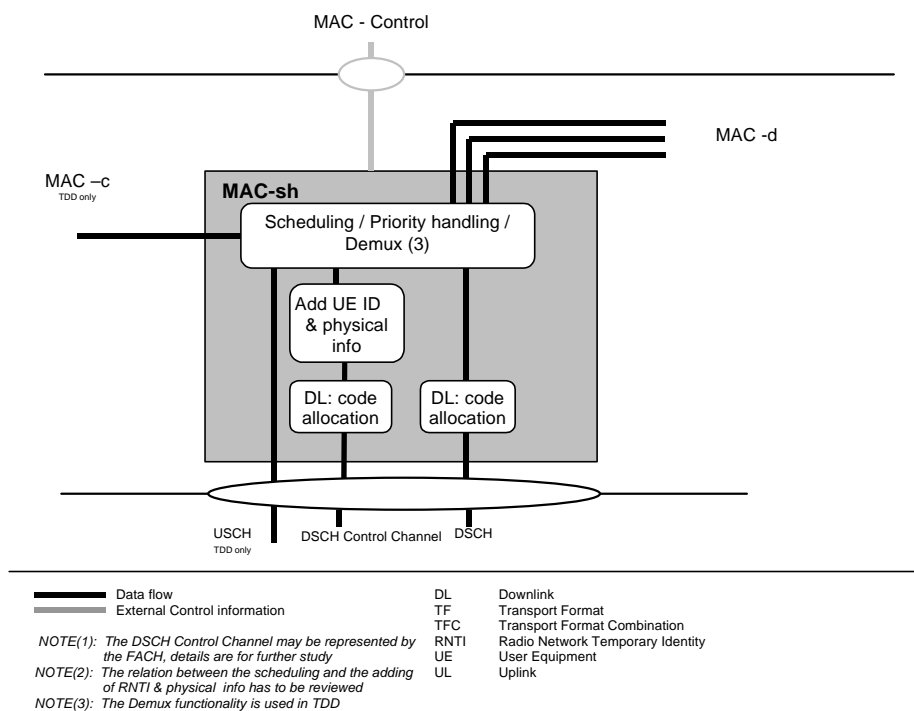

Figure 4.2.4.4 UTRAN side MAC architecture / MAC-sh details

4.3 Channel structure

The MAC operates on the channels defined below; the transport channels are described between MAC and Layer1, the logical channels are described between MAC and RLC. The following sections provide an overview, the normative description can be found in [2] and [3] respectively.

4.3.1 Transport channels

Common transport channel types are:

- Random Access Channel(s) (RACH)
- Forward Access Channel(s) (FACH)
- Downlink Shared Channel(s) (DSCH)
- DSCH Control Channel
- Uplink Shared Channel(s) (USCH), for TDD operation only
- ODMA Random Access Channel(s) (ORACH)
- Broadcast Channel (BCH)
- Synchronisation Channel (SCH), for TDD operation only
- Paging Channel (PCH)

Dedicated transport channel types are:

- Dedicated Channel (DCH)
- Fast Uplink Signalling Channel (FAUSCH)
- ODMA Dedicated Channel (ODCH)

4.3.2 Logical Channels

The MAC layer provides data transfer services on logical channels. A set of logical channel types is defined for different kinds of data transfer services as offered by MAC. Each logical channel type is defined by what type of information is transferred.

4.3.2.1 Logical channel structure

The configuration of logical channel types is depicted in Figure 4.3.2.1:

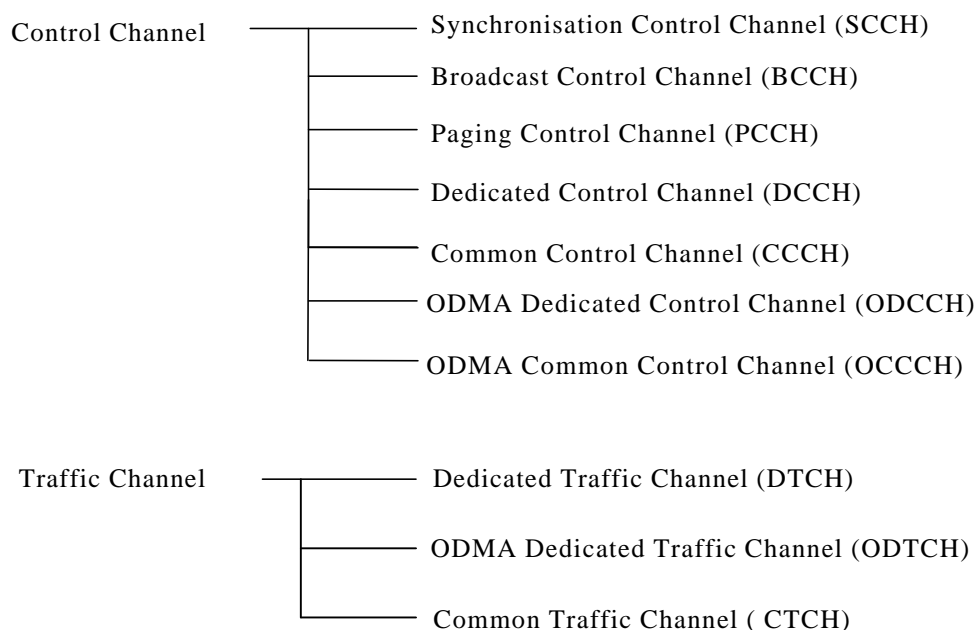

Figure 4.3.2.1 : Logical channel structure

4.3.2.2 Control Channels

Following control channels are used for transfer of control plane information only:

- Synchronisation Control Channel (SCCH)
- Broadcast Control Channel (BCCH)
- Paging Control Channel (PCCH)
- Common Control Channel (CCCH)
- Dedicated Control Channel (DCCH)
- ODMA Common Control Channel (OCCCH)
- ODMA Dedicated Control Channel (ODCCH)

4.3.2.3 Traffic Channels

Following traffic channels are used for the transfer of user plane information only:

- Dedicated Traffic Channel (DTCH)
- ODMA Dedicated Traffic Channel (ODTCH)
- Common Traffic Channel (CTCH)

4.3.3 Mapping between logical channels and transport channels

The following connections between logical channels and transport channels exist:

- SCCH is connected to SCH
- BCCH is connected to BCH
- PCCH is connected to PCH
- CCCH is connected to RACH and FACH
- DCCH and DTCH can be connected to either RACH and FACH, to RACH and DSCH, to DCH and DSCH, or to a DCH, the DCCH can be connected to FAUSCH.
- ODCCH, OCCCH and ODTCH can be connected to ORACH, ODCCH and ODTCH can be connected to ODCH.

- CTCH may be mapped to FACH and DSCH or BCH, the mapping is ffs
- DCCH and DTCH can be mapped to the USCH (TDD only).

5. Services provided to upper layers

5.1 Description of Services provided to upper layers

Data transfer

- Reallocation of radio resources and MAC parameters
- Reporting of measurements

The following potential service is regarded as a further study item:

- Allocation/de-allocation of radio resources

6. Functions

6.1 Description of the MAC functions

The functions of MAC include:

- Mapping between logical channels and transport channels.
- Selection of appropriate Transport Format for each Transport Channel depending on instantaneous source rate
- Priority handling between data flows of one UE
- Priority handling between UEs by means of dynamic scheduling
- Priority handling between data flows of several users on the the DSCH and FACH
- Scheduling of broadcast, paging and notification messages
- Identification of UEs on common transport channels
- Multiplexing/demultiplexing of higher layer PDUs into/from transport blocks delivered to/from the physical layer on common transport channels
- Multiplexing/demultiplexing of higher layer PDUs into/from transport block sets delivered to/from the physical layer on dedicated transport channels
- Traffic volume monitoring
- Monitoring the links of the assigned resources
- Routing of higher layer signalling
- Maintenance of a MAC signalling connection between peer MAC entities
- Dynamic Transport Channel type switching

The following potential functions is regarded as further study items:

- Constrained execution of open loop power control algorithms
- Processing of messages received at common control channels
- Successive Transmission on RACH
- Ciphering
- Access Service Class selection for RACH transmission.

6.2 Relation between MAC Functions / Transport Channels and UE

6.2.1 Relation between MAC Functions and Transport Channels

Associated MAC Functions	Logical Ch	Transport Ch	TF Selection	Priority handling between users	Priority handling (one user)	Scheduling	Identification of UEs	Mux/Demux on common transport CH	Mux/Demux on dedicated transport CH	Dynamic transport CH switching
Uplink (Rx)	CCCH	RACH						X		
	DCCH	RACH					X	X		
	DCCH	DCH							X	
	DTCH	RACH					X	X		
	DTCH	DCH							X	
Downlink (Tx)	SCCH	SCH								
	BCCH	BCH				X				
	PCCH	PCH				X				
	CCCH	FACH		X				X		
	DCCH	FACH		X			X	X		
	DCCH	DSCH		X				X		
	DCCH	DCH	X		X				X	
	DTCH	FACH	X(note1)	X			X	X		X
	DTCH	DSCH	X(note2)	X				X		X
DTCH	DCH	X		X				X	X	

Table 1 UTRAN MAC functions corresponding to the transport channel (note3)

(Note1) On FACH channel, the transport format set is limited.

(Note2) Whether DSCH has the transport format set is under discussion.

(Note3) The functions not included in the table are listed below.

- Mapping between logical channels and transport channels.
- Traffic volume monitoring
- Constrained execution of open loop power control algorithms

Further, the following additional functions are not included yet in the table :

- Routing of higher layer signalling
- Maintenance of a MAC signalling connection between peer MAC entities
- Monitoring the links of the assigned resources
- Processing of messages received at common control channels

Note (this table has to be reviewed)

6.2.2 Relation of UE MAC functions corresponding to the Transport Channel MAC Functions and Transport Channels

Functions	Logical Ch	Transport Ch	TF Selection	Priority handling data of one user	Identification	Mux/Demux on common transport channels	Mux/Demux on dedicated transport channels	Dynamic transport channel type switching
Uplink (Tx)	CCCH	RACH				X		
	DCCH	RACH	X(note1)		X	X		
	DCCH	DCH	X	X			X	
	DTCH	RACH	X(note1)		X	X		X
	DTCH	DCH	X	X			X	X
Downlink (Rx)	SCCH	SCH						
	BCCH	BCH						
	PCCH	PCH						
	CCCH	FACH				X		
	DCCH	FACH			X	X		
	DCCH	DSCH				X		
	DCCH	DCH					X	
	DTCH	FACH			X	X		
	DTCH	DSCH				X		
DTCH	DCH					X		

Table 2 UE MAC functions corresponding to the transport channel

(Note1) The RACH channel has the limited transport format set.

Note: This table has to be reviewed

7. Services expected from physical layer

see [TS25.302](#)

8. Elements for layer-to-layer communication

8.1 Primitives between layers 1 and 2

see [TS25.302](#)

8.2 Primitives between MAC and RLC

8.2.1 Primitives

The primitives between MAC layer and RLC layer are shown in Table 8.2.1.1

Generic Name	Type				Parameters
	Request	Indication	Response	Confirm	
MAC-DATA	X	X			MU
MAC-ERROR		X			[FFS]
MAC-STATUS		X	X		[FFS]

Table 8.2.1 Primitives between MAC layer and RLC layer

MAC-DATA Request/Indication

- MAC-DATA Request primitive is used to request that an upper layer PDU be sent using the procedures for the information transfer service.
- MAC-DATA Indication primitive indicates the arrival of an upper layer PDU received by means of the information transfer service.

MAC-ERROR Indication

- MAC-ERROR Indication primitive indicates to RLC that an error condition has occurred.

MAC-STATUS Indication/Response

- MAC-STATUS Indication primitive indicates to RLC about changes in the rules under which it may transfer data to MAC. Parameters of the primitive can indicate a transmission timer value, whether the RLC can transfer data and whether that data is restricted to supervisory frames only.
- MAC-STATUS Response enables RLC to acknowledge a MAC-STATUS Indication. It is possible that RLC would use this primitive to indicate that it has nothing to send or that it is in a suspended state.

8.2.2 Parameters

a) Message Unit (MU)

It contains the RLC layer message (RLC-PDU) to be transmitted or received by the MAC sub-layer.

[Note (from Tdoc WG2 009/99): This description are based on L2-LAC specification drafted TTC/ARIB Joint meeting. Because SAP between LAC and MAC is defined in our structure of MAC, the name of Signal is changed to Primitive. And format of explanation of primitives are changed to avoid verbose description. Request and Indication are combined to explain. Primitives for Activation/Deactivation or Establish/Release or Connect/Disconnect for MAC connection are FFS.]

[Note (from Tdoc WG2 009/99): The parameters for RLCMAC-ERROR and RLCMAC-STATUS are FFS.]

8.3 Primitives between MAC and RRC

8.3.1 Primitives

The primitives between MAC and RRC are shown in Table 8.3.1

Generic Name	Type				Parameters
	Request	Indication	Response	Confirm	
CMAC-CONFIG	X				CHI
CMAC-CONNECT	X			X	ffs
CMAC-MEASUREMENT	X	X			TRIG. TH, RESULT, PER
CMAC-STATUS		X			Status info.
CMAC-ERROR		X			Reason for error

Table 8.3.1 Primitives between MAC sub-layer and RRC

CMAC-CONFIG Request

- CMAC-CONFIG Request is used to request for the switching the connection between logical channels and transport channels

CMAC-CONNECT Request/Confirm

- CMAC-CONNECT Request is used initiate a RRC connection
- CMAC-CONNECT Confirm is used to confirm the establishment of a RRC connection.

CMAC-MEASUREMENT Request/Indication

- CMAC-MEASUREMENT .Request is used to request to measure something radio quality at both BS and MS sides. (for example : Transport Block Error)
- CMAC-MEASUREMENT. Indication is used to notify measuring result.

CMAC-STATUS Indication

- CMAC-STATUS Indication primitive notifies the management entity of status information.

CMAC-ERROR Indication

- CMAC-ERROR Indication primitive notifies the management entity of an error detected in the operation of the MAC sub layer protocol such as excessive number of transmission attempts for Ack-mode. and timer time out.

8.3.2 Parameters

- a) Channel Information (CHI)
Channel information for active transport channel. For example, common channel or dedicated channel notification in user packet transmission.
- b) TH
Threshold information for measurement. For example, traffic monitor or transmission quality. When an specific value is assigned, it means measuring should be reported with law data.
- c) PER
Period information for measurement. When an specific value is assigned, it means measuring should be reported only when measuring result exceed the given threshold.

- d) TRIG
Trigger information which request to start measuring.
- e) RESULT
Measurement result.
- f) Status info
It is management entity of status information.
- g) Reason for error
It contains the management entity of an error detected in the operation of the MAC sub layer protocol (e.g. excessive number of transmission attempts for Ack-mode).

[Note(from Tdoc WG2 009/99): If used with a threshold information, the MEASURE primitive is same as an alarm indication or request for channel switching. When the condition that channel switching is needed is detected at MS side, appropriate RRC message will be sent to Network side.

9. Elements for peer-to-peer communication

9.1 Protocol data units

9.1.1 MAC Data PDU

MAC PDU consists of an optional MAC header and a MAC Service Data Unit (MAC SDU), see figure 9.1.1. Both the MAC header and the MAC SDU are of variable size.

The content and the size of the MAC header depends on the type of the logical channel, and in some cases none of the parameters in the MAC header are needed.

The size of the MAC-SDU depends on the size of the RLC-PDU, which is defined during the setup procedure.

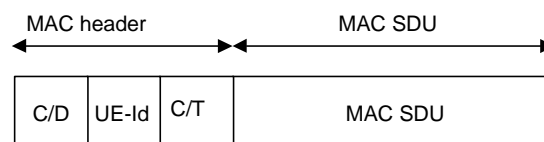

Figure 9.1.1.1 MAC data PDU

9.1.2 MAC Control PDU

MAC Control PDU consist elements for the control of the operation. The details are ffs.

9.1.3 MAC messages for MAC peer to peer communication

(Editors note: Based on Tdoc TSGRAN WG2 285/ 99 for the use of MAC peer to peer communication WG2 has agreed to incorporate MAC messages for peer to peer communication into S2.21, details are for further study.)

9.2 Formats and parameters

9.2.1 MAC Data PDU: Parameters of the MAC header

The following fields are defined for the MAC header:

- **C/D field**
The C/D field is a single-bit flag that provides identification of the logical channel class on FACH and RACH transport channels, i.e. whether it carries CCCH or dedicated logical channel information.

C/D field	Designation
1	CCCH
0	DCCH or DTCH

Table 9.2.1.1: Coding of the C/D Field

- **C/T field**
The C/T field provides identification of the logical channel instance when multiple logical channels are carried on the same transport channel. The C/T field is used also to provide identification of the logical channel type on dedicated transport channels and on FACH and RACH when used for user data transmission. The size of the C/T field may be variable.

C/T field (e.g. 4 bits)	Designation
0000	Logical channel 1
0001	Logical channel 2
...	...
1111	Logical channel 16

Table 9.2.1.2: Structure of the C/T field

- **UE-Id**
The UE-Id field provides an identifier of the UE . The following types of UE-Id are currently defined:

s-RNTI , this UE Id is related to the serving RNC

c-RNTI, this UE Id is related to the controlling RNC.

In addition for UE's having a RRC connection the S-RNC identifier exist.

s-RNTI together with S-RNC identifier is used for URA update RRC connection reestablishment and UTRAN originated paging messages and there associated responses.

c-RNTI is used as a UE identifier in all other DCCH/DTCH common channel messages on the air interface.

Editors note: Whether or not other UE-Id types are needed is ffs.

9.2.1.1 MAC header for DTCH and DCCH

- a) DTCH or DCCH mapped to DCH, no multiplexing of dedicated channels on MAC:
No MAC header is required.
- b) DTCH or DCCH mapped to DCH, with multiplexing of dedicated channels on MAC:
C/T field is included in MAC header.
- c) DTCH or DCCH mapped to RACH/FACH:
C/D field and UE-Id are included in the MAC header. C/T field is included if multiplexing on MAC is applied.
- d) DTCH or DCCH mapped to RACH/FACH, where DTCH or DCCH are the only channels (ffs).
UE-Id field is included in MAC header. C/T field is included if multiplexing on MAC is applied.
- e) DTCH or DCCH mapped to DSCH:
The MAC-PDU format for DSCH is left for further study.

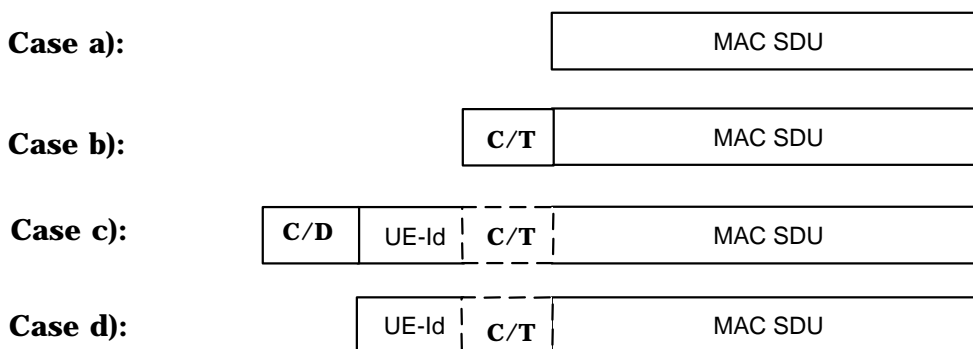

Figure 9.2.2.1: MAC Data PDU formats for DTCH and DCCH

9.2.1.2 MAC header for CCCH

Editors note: The concept for using UE Id on CCCH has to be reviewed

- a) CCCH mapped to RACH/FACH:
C/D has to be included and UE-id field may be included in MAC header. Details of usage the UE-id field is ffs.
- b) CCCH mapped to RACH/FACH, where CCCH is the only channel (ffs):
UE-id field may be included in the MAC header.

Editors note: The usage of the MAC header for BCCH and PCCH is ffs.

The address used for initial addressing is ffs, a possible solution may be to use a Random or CN related Identifier.

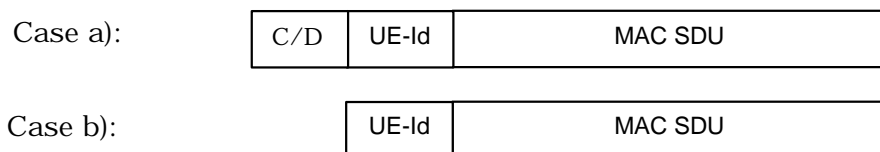

Figure 9.2.1.2.1 : MAC Data PDU formats for CCCH

9.2.2 Control PDUs

MAC Control PDU elements have to be described, the details are ffs.

9.2.3 Format of MAC messages for MAC peer to peer communication

(Editors note: Based on Tdoc TSGRAN WG2 285/ 99 for the use of MAC peer to peer communication WG2 has agreed to incorporate MAC messages for peer to peer communication into S2.21, details are for further study.)

9.3 Protocol states

(Description of states, provision of state transition diagram(s))

9.4 State variables

9.5 Timers

9.6 Protocol Parameters

(e.g. max, min values of state variables to be initialised)

9.7 Specific functions

(description of specific protocol functions, if applicable)

10. Handling of unknown, unforeseen and erroneous protocol data

11. Elementary procedures

Examples: data transfer, random access procedure, transport channel type switching (dedicated/common channel)

11.1 Dynamic radio bearer control in UE

- This procedure is applicable only in case of optimisation of established radio bearers
- The algorithm exist in the UE and is controlled by the network. The algorithm requests to RRC for a reconfiguring of radio resources, details are ffs.

12. History

Document history		
Date	Version	Comment
January 1999	0.0.1	Document created. Based on TSG RAN WG2 Tdoc 015/99, 009/99 and 028/99.
March 1999	0.0.2	Document adapted to the new 3GPP layout, reflects email discussion on MAC-sh, descriptions for FAUSCH handling moved to MAC-d
April 1999	0.0.3	Changes after TSG RAN WG2#2: Service Access Classes , Scheduling function UTRAN side MAC-d and modified PDU format incorporated, MAC-RLC and MAC-RRC primitives renamed.
April 1999	0.1.0	Changes after TSG RAN WG2#3: List of Channels, MAC functions updated, Update for UE Id usage. Incorporation of USCH, MAC-sh updated, Changes to support MAC per to peer communication. Retransmission removed from MAC-c, MAC PDU updated. Document for approval by TSG RAN.
April 1999	TS 25.321 V2.0.0	Endorsed by TSG-RAN as TS 25.321 V2.0.0
May 1999	<u>TS 25.321</u> <u>V2.0.1</u>	<u>References updated after TSG RAN #3</u>
Rapporteur for TS 25.321 is:		
Armin Sitte Siemens AG Tel.: +49 30 386 29077 Fax:.....+49 30 386 25548 GSM:....+49 172 382 4532 e-mail: armin.sitte@icn.siemens.de		
This document is written in Microsoft Word Version 97 SR-1 and saved in Rich Text Format.		

13. Appendices: Examples of operation

14. Annex 1: MAC Functions

Note: This Annex contains information based from Tdoc TSG_RAN_WG2 009/99, the text has to be reviewed, the functions will then be moved into the main part of the document.

14.1 General functions

-- Traffic Monitor Function:

The Traffic monitor function measures traffic amount of the logical channels for controlling the Switching Function by RRC.

-- Switching Function:

The Switching Function houses less time-critical functions that need co-ordination among different transport channel formats such as the execution of the switch between FACH/RACH and DCHs, and vice versa. The Switching Function also communicates with RRC in order to appropriately deal with DCCH and DTCH.

-- Multiplexing Function:

The Multiplexing Function multiplexes/de-multiplexes data between the logical channel (CCCH, DCCH and DTCH) and the transport channels (FACH and RACH) in consideration of the appropriate prioritisation. The transport channels are de-multiplexed by using LID (Logical Channel Identifier).

i) On condition that LID of a MAC-PDU from FACH/RACH indicates "10000" - "11111", the MAC PDU is transmitted to DTCH.

ii) On condition that LID of a MAC PDU from FACH/RACH indicates "00100", the MAC PDU is transmitted to DCCH.

Furthermore, the Multiplexing function can multiplex data from several instances of the logical channels DTCH and BCCH onto their respective transport channels, i.e. DCH and BCH. For DTCH, demultiplexing from one DCH to several DTCHs is also handled

iii) Using LID of a MAC PDU from DCH, the MAC PDU is transmitted to the appropriate DTCH.

iv) Using LID of a MAC PDU from BCCH, the MAC PDU is transmitted to the appropriate BCH.

-- Retransmission Function:

The Retransmission Function realises a stop-and-wait ARQ scheme over FACH and RACH. This function is omitted if RRC sets the maximum number of retransmission (N_{RA}) to 0.

Note(Tdoc 009/99): Retransmission Function in MAC sublayer is FFS.

-- MAC Header Handling Function

This function is applied to RACH, FACH, BCH and DCH. This function constructs MAC header and adds the header to LAC-PDU to assemble MAC-PDU. And this function deletes MAC header from MAC-PDU to disassemble LAC-PDU and informs the retransmission function and the multiplexing function of contents included in the header.

FACH-ACK is returned from BSS to MS as a MAC header when BSS received correctly MAC-PDU through RACH.

This function constructs FACH-ACK based on information from the retransmission function that includes RNTI of RACH received correctly.

-- Access Control Function:

The Access Control Function makes a schedule for transport blocks (MAC-PDUs) into the transport channels and synchronises with physical layer in building transport block sets that are transmitted as radio frames by physical layer. If RACH is used for transport channel, slotted ALOHA is adopted as multi-access scheme in Access Control Function.

14.2 Common channel related functions

14.2.1 Control of BCH

14.2.1.1 Overview

The Scheduling Functions are used for control of BCH.

14.2.1.2 Scheduling of BCH

Related MAC function entity: ACFE - Access Control function

Two kinds of BCH are mapped to the perch channel. One of them is for BCCH-C transmission, the other is for BCCH-V transmission. Access Control Function in ACFE makes a schedule for two kinds of BCH messages into the BCH in consideration of SFN (System Frame Number).

14.2.2 Control of PCH

14.2.2.1 Overview

The Scheduling Function is used for control of PCH.

[Note (Tdoc 009/99): Retransmission function is not applied to PCH in MAC. Retransmission of paging message is achieved by layer 3 protocol.]

14.2.2.2 Scheduling of PCH

Related MAC function entity: ACFE - Access Control function

Access Control Function in ACFE makes a schedule for PCCH LAC-PDUs of 288 paging groups based on the group identifier indicated by the upper layer.

14.2.3 Control of FACH

14.2.3.1 Overview

The Forward Access Channel (FACH) is used in the forward link to carry control information and user packets to a mobile station. The functions associated with the FACH are

- Scheduling
- Multiplexing / demultiplexing
- Inband identification of MSs
- Selection of appropriate transport format (see 14.1)

Procedures associated with the FACH are

- Random access procedure (see 15.1)

14.2.3.2 Scheduling of ACK, control and user data transmission

Related MAC function entity: ACFE - Access Control Function

This function provides mechanisms for efficient transfer of FACH-ACK (see 14.1, 15.1), control and user data by means of appropriate scheduling of the messages. This includes the usage of priority information. The priority is arranged in the following order:

1. FACH-ACK
2. Control
3. User

When the information content is the same, the information that gave transmission request earliest shall be transmitted with the highest priority (FIFO). FACH-ACK shall always be transmitted in the first timeslot set. Further scheduling rules are:

- When the information amount of the higher layer information type transmitted by FACH radio unit is worth of plural number of FACH radio units, transmission continuous in time is guaranteed. In no case, other higher layer information types can break in and be transmitted. The FACH-ACK is transmitted at the highest priority as aforesaid, but can never break a long FACH radio unit.
- The MS shall be able to simultaneously receive all FACH on one Common Physical Channel. When multiple number of physical channels for common control for transmitting FACH are transmitted from the BSS, the MS shall receive only one Common Physical Channel.
- The FACH-ACK can mount maximal 7 of RNTI (see Annex 3)
- The FACH-ACK shall be transmitted with the highest priority even if its transmission request timing comes later than other FACHs.
- When there are some cases that ACK was not returned for the RACH that detected CRC OK at the time immediately before the transmission timing of radio frame for FACH, the ACK-FACH shall be transmitted by the first FACH from the ones that have the oldest timing among those that received CRC OK. However, those that already passed T_{BS-ACK} msec or more after detecting CRC OK shall be removed from the list of transmitting ACK mode FACH.

14.2.3.3 Multiplexing/demultiplexing of higher layer PDUs to/from a FACH

Related MAC function entity: ACFE-Multiplexing Function

MAC should support service multiplexing for common transport channels, since the physical layer does not support multiplexing of these channels. This includes multiplexing of data from the U-plane and from the C-plane. The data blocks are put together according to the scheduling of control and user data before being sent on the FACH.

14.2.3.4 Inband identification of MSs

Related MAC function entity: ACFE - Access Control Function

When a particular MS is addressed on FACH, there is a need for inband identification of the MS. This is because on the FACH there is no user separation by code or frequency like on dedicated channels. Since the MAC layer handles the access to, and multiplexing onto, the transport channels, the identification functionality is naturally also placed in MAC. The MS is identified by the RNTI. This RNTI is notified by RRC messages (see Annex 3).

14.2.4 Control of RACH

Note (see Tdoc TSG_RAN_WG2 009/99) : The random selection of spreading codes is related to the usage of signatures, and is therefore to be discussed in WG1.

14.2.4.1 Overview

The Random Access Channel (RACH) is used in the reverse link to carry control information and user packets from a mobile station. The functions associated with the RACH are

- Scheduling
- Multiplexing/demultiplexing
- Inband identification of MSs
- Selection of appropriate transport format (see 14.1)

Procedures associated with the RACH are

- Random access procedure (see 15.1)

14.2.4.2 Scheduling of control and user data transmission

Related MAC function entity: ACFE – Access Control Function

This function provides mechanisms for efficient transfer of control and user data by means of appropriate scheduling and repetition of the RACH transport blocks. The control data has higher priority than user data.

Random Access/Packet mode:

Initial Transmission:

- When the mobile station begins to transmit the first radio frame of RACH transport blocks, the transmission timing offset, the RACH spreading code and the signature shall be determined as follows:

The transmission timing offset (frame and/or slot), the RACH spreading code and the signature of the first radio frame on a RACH are determined pseudo-randomly. Possible timing offsets, spreading codes and signatures are determined by a set broadcasted via BCCH. The MAC header generation is described in the section on the PDU format (9.2.1).

Succeeding Transmission:

- When the mobile station continues to transmit the succeeding (second or more) radio frames because the layer 3 message length is longer than a RACH transport block size, the transmission timing offset, the RACH spreading code and signature shall be determined as follows:
The transmission timing offset (frame and/or slot) shall be determined pseudo-randomly. The RACH spreading code and the signature of the succeeding radio frame can be determined pseudo-randomly. The same RNTI shall be used as in the previous radio frame (for the radio frames belonging to the same CPS).

Retransmission:

- If the mobile station fails to receive an ACK within T_{MS-ACK} msec it retransmits the radio frame after a pseudo-random delay. This implies automatically the use of the same RNTI for retransmission. The maximum number of allowed retransmissions shall be set to N_{RA} . Transmission timing offset, RACH spreading code and signature may be adapted in order to decrease collision probability.

14.2.4.3 Multiplexing/demultiplexing of higher layer PDUs to/from a RACH

Related MAC function entity: ACFE - Multiplexing Function

MAC should support service multiplexing for common transport channels, since the physical layer does not support multiplexing of these channels.

14.2.4.4 Inband Identification of MSs

Related MAC function entity: ACFE - Access Control Function

The unambiguous separation of different MSs using the contention based RACH channel is handled by MAC. When a particular MS is using the RACH, there is a need for inband identification of the MS. Since the MAC layer handles the access to, and multiplexing onto, the transport channels, the identification functionality is naturally also placed in MAC. When several random access packets are received at the BS the physical layer detects them and delivers them to the MAC. The MAC distinguishes the valid random access packets by different RNTIs. Thus the MS is identified by the RNTI.

14.3 Control of DCH

14.3.1 Overview

Functions associated with dedicated channels are:

- Selection of appropriate transport format (described in other functions)
- Priority handling between data flows of one MS
- Traffic volume monitoring (described in other functions)

14.3.2 Priority handling between data flows of one MS

Related MAC function entity: ACFE – Access Control Function

When selecting between the allowed transport formats for a given user, priorities of data flows to be mapped onto the corresponding Transport Channels can be taken into account. Priorities are e.g. given by attributes of radio bearer services and transmitter buffer status. Priority handling is achieved by selecting a "high bit rate" transport format for high-priority data, at the same time letting lower priority data be mapped with a "low bit rate" (could be zero bit rate) transport format.

In this case the load control facilities within RRC control only the aggregate capacity of the user. With this approach, fast re-scheduling with the resolution of transport blocks is possible. Scheduling on MAC can be the primary approach also when multiplexing is done on the physical layer.

If different NRT (non-real-time) radio bearers require different channel coding (or service-specific rate matching), i.e. scheduling is done among multiple dedicated channels, there may be no simple rule for performing the scheduling function between these services. This matter may require further study. Also, MAC cannot re-schedule traffic that has been scheduled by a higher layer.

14.4 Other functions

This section contains functions that are not directly associated with any specific type of transport channels or which should be seen as operations, where MAC shares the responsibility for the function with RRC. Where RRC participation is assumed, a more detailed description of the MAC operation is given below.

Other functions currently consist of:

- Selection of appropriate transport format (applicable to DCH, RACH, FACH)
- Traffic volume measurement (reporting to RRC)
- Channel type switching execution (decision by RRC)
- Priority handling between different users by means of scheduling (Resource division between users controlled by RRC, thus may later be moved to RRC)

14.4.1 Selection of appropriate transport format

Related MAC function entity: ACFE – Access Control Function

MAC chooses the appropriate transport format within the transport format combination set according to the required transmission rate (see 14.1).

For RACH and FACH, the present specification defines two kinds of transport format.

14.4.2 Traffic volume measurement

Related MAC function entity: MAFE – Traffic Monitoring Function

Measurement of traffic volume and reporting to RRC.

The information on traffic volume and transmitter buffer status can influence admission control and the allocation of transport formats by RRC. The same information is sent by MAC to RRC that uses the information as a basis for the decision if channel type switching needs to be performed (see 14.1). Indication of needed switching from common to dedicated, from dedicated to common channels or from dedicated to dedicated channel with different rate is based on the traffic volume measurements. This information is passed to RRC.

14.4.3 Channel type switching execution

Related MAC function entity: MAFE – Switching Function

Execution of the switching between common (RACH and FACH) and dedicated transport channels. It is currently assumed, that based on the traffic volume measurements of MAC (5.1) RRC makes the decision on channel type switching and signals the transition to both peer MAC entities, which then execute the switch.

This function means connecting the logical DTCH to either RACH and FACH, or a dedicated transport channel.

14.4.4 Priority handling between data flows of different users by means of scheduling

Related MAC function entity: MAFE – Traffic Monitoring Function

[Editor's note: For dedicated channels, this part may be later moved to RRC.]

In order to utilize the spectrum resources efficiently for bursty traffic (packet), a dynamic scheduling function may be applied. The control of radio resources between users is an RRC function. MAC, being the entry point for user data within BSS, has the function to perform the needed resource negotiation with RRC. This is closely connected to traffic volume monitoring and is thus performed by MAFE.

In the downlink the scheduling function can be realized by coordinating the requests for transport format combination sets for different users appropriately, taking the maximum allowed interference level and radio access bearer priorities (or corresponding) of different users into account in RRC. In the uplink the same functionality can be achieved, but then requiring messages across the air interface for fast resource requests and allocations of transport format combination sets.

14.4.5 Ciphering

[FFS]

15. Annex 2: MAC Procedures / Elementary Procedures

Note: This Annex contains information based from Tdoc TSG_RAN_WG2 009/99, the text has to be reviewed, the description of the functions will then be moved into the main part of the document.

15.1 Random access procedure

- The Random access procedure is based on the slotted ALOHA algorithm.
- Stop & wait ARQ procedure is applied to RACH transmission. After an MS transmits a transport block on a RACH, MS should wait to receive an acknowledgement(ACK) from a BSS on a FACH. Detail of the procedure is following:
 - 1) BSS broadcasts codes of FACH, which is used in the sector, on BCCH-C. For example, C1, C2 and C3 are broadcasted in this order.
 - 2) The MS selects RNTI randomly, when a transport block to be transmitted on a RACH is generated in an MS and when MS has not been assigned any RNTI by BSS.
 - 3) In order to decide spreading code of FACH for ACK reception, the MS calculates a remainder of the RNTI value divided by the number of codes of FACHs used in the sector. But, this procedure is omitted if the maximal number of RACH transmission, "N_{RA}" equals to 1 (RACH retransmission is not necessary).
 - 4) The MS constructs an RACH transport block with the RNTI.
 - 5) The MS selects a spreading code, transmission timing and signature pattern, randomly.
 - 6) The MS transmits an RACH transport block on a radio frame using a selected spreading code, transmission timing and signature pattern.
 - 7) If N_{RA} equals to 1, the MS omits following procedure and starts procedure from 2) again. MS can transmit plural RACH transport blocks using succeeding radio frames in case of N_{RA}=1.
 - 8) The MS starts a timer, T_{MS-ACK}.
 - 9) The MS waits to receive an ACK from the BSS on the FACH corresponding to calculation results (Ex. If the calculation result equal to 0, 1 or 2 in case that three codes are used for FACH in the sector, the MS waits to receive the ACK on FACH spread with C1, C2 or C3, respectively).
 - 10) When BSS received RACH transport block correctly, BSS calculates a remainder in the same way as MS does using the RNTI received on RACH.
 - 11) BSS constructs FACH-ACK to be transmitted on FACH. The FACH-ACK includes RNTI of correctly received RACH (see 9.2).
 - 12) The BSS transmit the FACH-ACK on the FACH corresponding to the calculation result. (Ex. If the calculation result equal to 0, 1 or 2 in case that three codes are used for FACH in the sector, the BSS transmit the FACH-ACK on FACH spread with C1, C2 or C3, respectively.) BSS should transmit FACH-ACK within T_{BS-ACK} after correctly receiving the RACH radio frame from the MS. If BSS could not transmit FACH-ACK within T_{BS-ACK} because all radio frames on a FACH within T_{BS-ACK} are used for other FACH-ACK transmission, the FACH-ACK is discarded in BSS.
 - 13) If the MS receives FACH-ACK including the corresponding RNTI and has another message to be transmitted on RACH, the MS start RACH transmission procedure from 2) again.
 - 14) If the MS fails to receive the FACH-ACK within T_{MS-ACK} after transmitting the RACH transport block, the MS retransmits the RACH transport block with same RNTI after a pseudo-random delay.
 - 15) If the number of transmission is equal or more than N_{RA}, MS should discard the RACH transport block.
- The ACK timeouts should be related like this: T_{MS-ACK} > T_{BS-ACK}.
- Figure 15.1.1 and Figure 15.1.2 show random access procedures in BSS and MS, respectively.

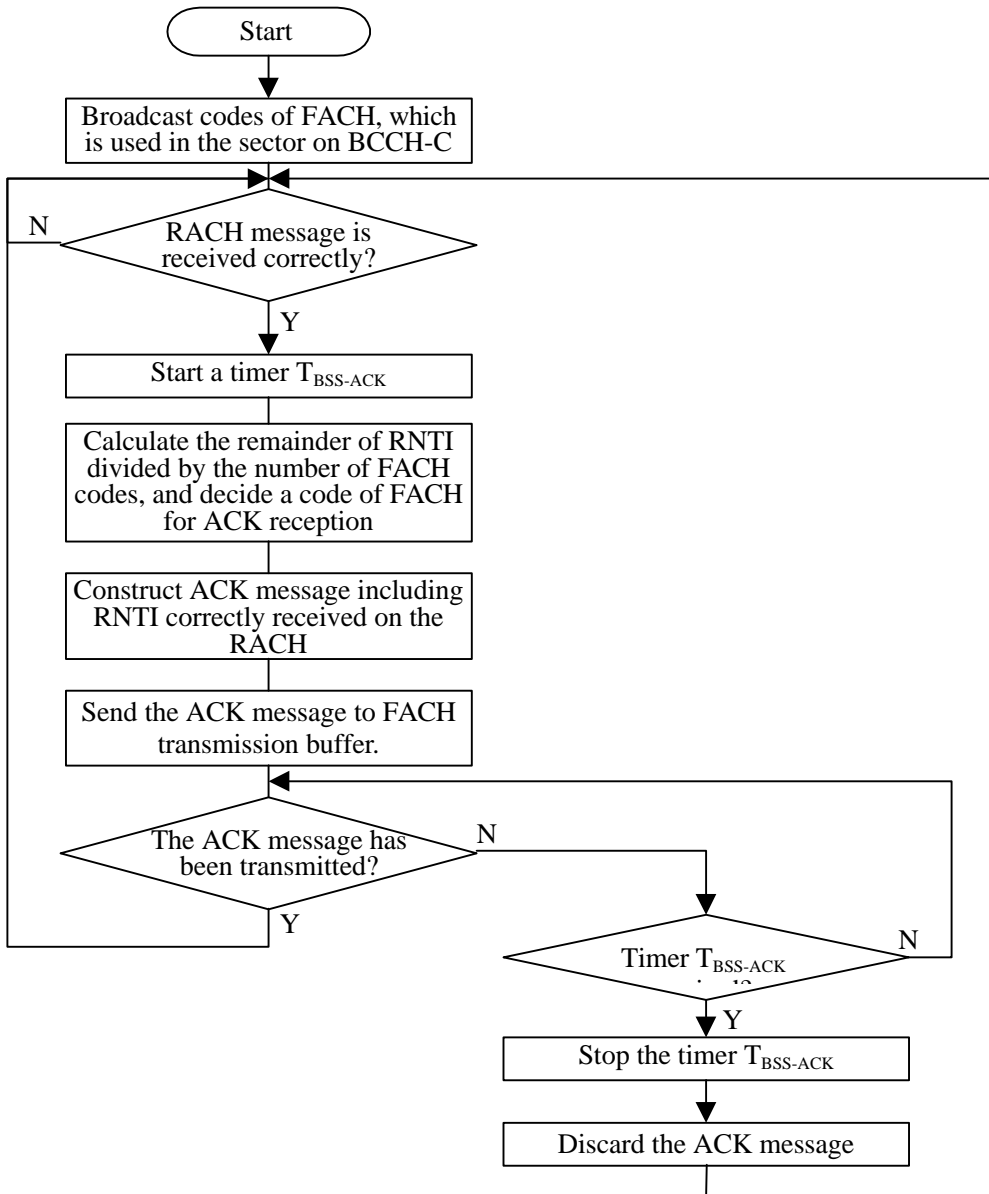

Fig. 15.1.1 Random access procedure in BSS

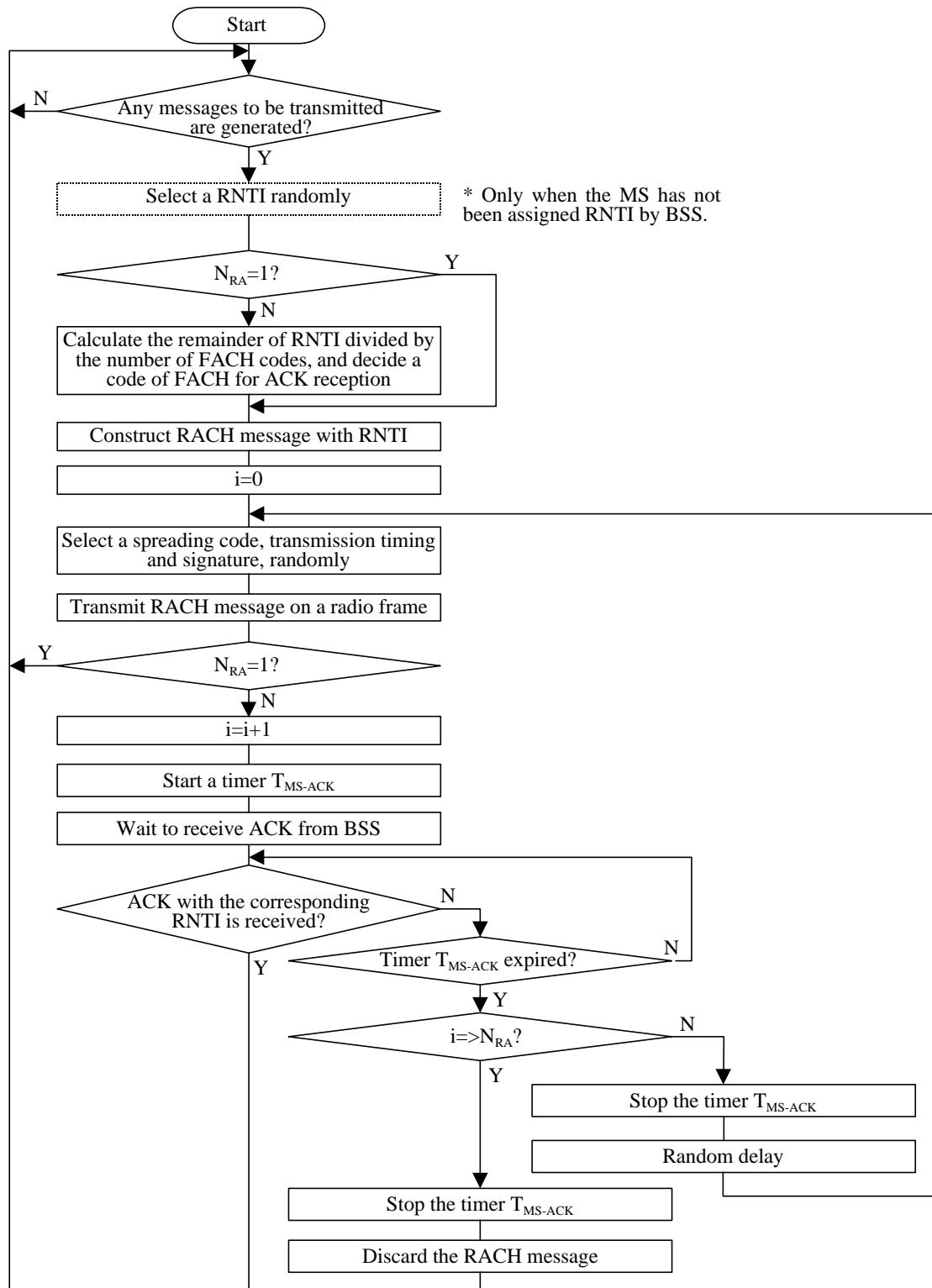

Fig. 15.1.2 Random access procedure in a MS

15.2 Channel type switching procedure

Note (from Tdoc 009/99) : This part may be later moved to RRC.

16. Annex 3: MAC parameters

Note: This Annex contains information based from Tdoc TSG_RAN_WG2 009/99, the text has to be reviewed , the description of the MAC parameters will then be moved into the main part of the document.

16.1 RNTI (Radio Network Temporary Identifier)

- This is an identifier to identify a call or MS related to the transmitted information on the common transport channel, RACH and FACH.
- Range of values: 0—65535
- Usage: Below are two main usage of RNTI.
 - i) DCH for DCCH set-up request, set-up response
The RNTI shall be used for the DCH for DCCH set up request on RACH from MS to BSS, as well as for the set up response on FACH from BSS to MS. The RNTI of the FACH that transmits the set-up response shall be the same RNTI of the RACH that transmitted the set-up request. The RNTI value for this usage shall be a value selected by the MS at random.
 - ii) Packet transmission
Packet data transmission on RACH and FACH. The RNTI value for this usage shall be decided by the RRC of BSS. MS is assigned a single RNTI even when MS handles several calls.
- Transmitted from the MSB side to the encoder.

16.2 LID (Logical Channel Identifier)

- This is an identifier to identify logical channel type related to the information mounted on MAC SDU, and identify FACH-ACK.
- When several DTCHs are assigned to an MS, this identifier identifies each DTCH.
- The bit configuration is presented in Table 16.2.1.

Bit	Identified content
0 0001	FACH-ACK
0 0010	CCCH
0 0100	DCCH
1 0000	DTCH0
1 0001	DTCH1
⋮	⋮
1 1111	DTCH15

Table 16.2.1 LID Bit Configuration

16.3 NR (The number of RNTI)

- This is included in FACH-ACK.
- This designates the number of RNTI within following RNTI field.
- Range of values: 1—7

16.4 RNTI Field

- This is included in FACH-ACK.
- Length of this field is 14 octets.
- This field includes RNTIs of RACHs received correctly by BSS.
- This field can accommodate the maximum number of 7 RNTIs in an FACH-ACK.

Figure 16.4.1 shows bit configuration examples of RNTI field.

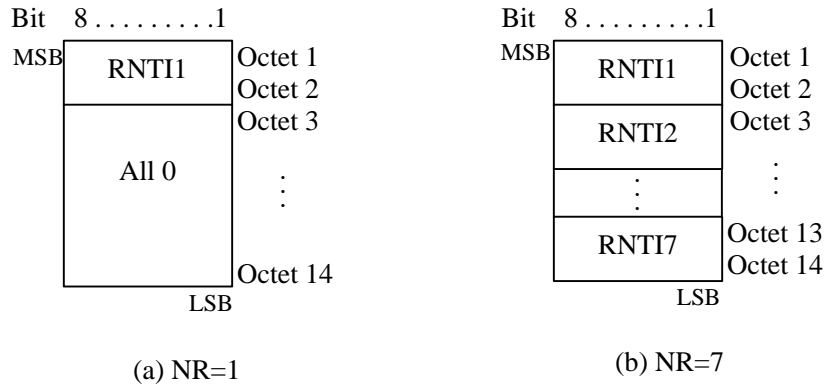

Fig. 16.4.1 Bit configuration examples of RNTI field