



## 4.2.5 1st interleaving

The 1<sup>st</sup> interleaving is a block interleaver with inter-column permutations. The input bit sequence to the 1<sup>st</sup> interleaver is denoted by  $x_{i,1}, x_{i,2}, x_{i,3}, \dots, x_{i,X_i}$ , where  $i$  is TrCH number and  $X_i$  the number of bits (at this stage  $X_i$  is assumed and guaranteed to be an integer multiple of TTI). The output bit sequence is derived as follows:

- 1) select the number of columns  $C_i$  from table 3;
- 2) determine the number of rows  $R_i$  defined as  $R_i = X_i / C_i$ ;
- 3) write the input bit sequence into the  $R_i \times C_i$  rectangular matrix row by row starting with bit  $x_{i,1}$  in the first column of the first row and ending with bit  $x_{i,(R_i \times C_i)}$  in column  $C_i$  of row  $R_i$ ;

$$\begin{bmatrix} x_{i,1} & x_{i,2} & x_{i,3} & \dots & x_{i,C_i} \\ x_{i,(C_i+1)} & x_{i,(C_i+2)} & x_{i,(C_i+3)} & \dots & x_{i,(2 \times C_i)} \\ \vdots & \vdots & \vdots & \dots & \vdots \\ x_{i,((R_i-1) \times C_i+1)} & x_{i,((R_i-1) \times C_i+2)} & x_{i,((R_i-1) \times C_i+3)} & \dots & x_{i,(R_i \times C_i)} \end{bmatrix}$$

$$\begin{bmatrix} x_{i1} & x_{i2} & x_{i3} & \dots & x_{iC_i} \\ x_{i,(C_i+1)} & x_{i,(C_i+2)} & x_{i,(C_i+3)} & \dots & x_{i,(2C_i)} \\ \vdots & \vdots & \vdots & \dots & \vdots \\ x_{i,((R_i-1)C_i+1)} & x_{i,((R_i-1)C_i+2)} & x_{i,((R_i-1)C_i+3)} & \dots & x_{i,(R_iC_i)} \end{bmatrix}$$

- 4) Perform the inter-column permutation based on the pattern  $\langle P_{C_i}(j) \rangle_{j \in \{0,1,\dots,C_i-1\}}$  shown in table 3, where  $P_{C_i}(j)$  is the original column position of the  $j$ -th permuted column. After permutation of the columns, the bits are denoted by  $y_{i,k}$ :

$$\begin{bmatrix} y_{i,1} & y_{i,(R_i+1)} & y_{i,(2 \times R_i+1)} & \dots & y_{i,((C_i-1) \times R_i+1)} \\ y_{i,2} & y_{i,(R_i+2)} & y_{i,(2 \times R_i+2)} & \dots & y_{i,((C_i-1) \times R_i+2)} \\ \vdots & \vdots & \vdots & \dots & \vdots \\ y_{i,R_i} & y_{i,(2 \times R_i)} & y_{i,(3 \times R_i)} & \dots & y_{i,(C_i \times R_i)} \end{bmatrix} \begin{bmatrix} y_{i1} & y_{i,(R_i+1)} & y_{i,(2R_i+1)} & \dots & y_{i,((C_i-1)R_i+1)} \\ y_{i2} & y_{i,(R_i+2)} & y_{i,(2R_i+2)} & \dots & y_{i,((C_i-1)R_i+2)} \\ \vdots & \vdots & \vdots & \dots & \vdots \\ y_{iR_i} & y_{i,(2R_i)} & y_{i,(3R_i)} & \dots & y_{i,(C_iR_i)} \end{bmatrix}$$

- 5) Read the output bit sequence  $y_{i1}, y_{i2}, y_{i3}, \dots, y_{i,(C_i \times R_i)}$  of the 1<sup>st</sup> interleaving column by column from the inter-column permuted  $R_i \times C_i$  matrix. Bit  $y_{i,1}$  corresponds to the first row of the first column and bit  $y_{i,(R_i \times C_i)}$  corresponds to row  $R_i$  of column  $C_i$ .

The bits input to the 1<sup>st</sup> interleaving are denoted by  $t_{i,1}, t_{i,2}, t_{i,3}, \dots, t_{i,T_i}$ , where  $i$  is the TrCH number and  $T_i$  the number of bits. Hence,  $x_{i,k} = t_{i,k}$  and  $X_i = T_i$ .

The bits output from the 1<sup>st</sup> interleaving are denoted by  $d_{i,1}, d_{i,2}, d_{i,3}, \dots, d_{i,T_i}$ , and  $d_{i,k} = y_{i,k}$ .

Table 3

TTI	Number of columns $C_1$	Inter-column permutation patterns $\langle P_{1C_1(0)}, \dots, P_{1C_1(C_1-1)} \rangle$
10 ms	1	$\langle \{0\} \rangle$
20 ms	2	$\langle \{0, 1\} \rangle$
40 ms	4	$\langle \{0, 2, 1, 3\} \rangle$
80 ms	8	$\langle \{0, 4, 2, 6, 1, 5, 3, 7\} \rangle$

## 4.2.6 Radio frame segmentation

When the transmission time interval is longer than 10 ms, the input bit sequence is segmented and mapped onto consecutive  $F_i$  radio frames. Following radio frame size equalisation the input bit sequence length is guaranteed to be an integer multiple of  $F_i$ .

The input bit sequence is denoted by  $x_{i1}, x_{i2}, x_{i3}, \dots, x_{iX_i}$  where  $i$  is the TrCH number and  $X_i$  is the number bits. The  $F_i$  output bit sequences per TTI are denoted by  $y_{i,n_1}, y_{i,n_2}, y_{i,n_3}, \dots, y_{i,n_{Y_i}}$  where  $n_i$  is the radio frame number in current TTI and  $Y_i$  is the number of bits per radio frame for TrCH  $i$ . The output sequences are defined as follows:

$$y_{i,n,k} = x_{i,((n-1)Y_i)+k}, n_i = 1 \dots F_i, k = 1 \dots Y_i$$

where

$$Y_i = (X_i / F_i) \text{ is the number of bits per segment.}$$

The  $n_i$ -th segment is mapped to the  $n_i$ -th radio frame of the transmission time interval.

The input bit sequence to the radio frame segmentation is denoted by  $d_{i1}, d_{i2}, d_{i3}, \dots, d_{iT_i}$ , where  $i$  is the TrCH number and  $T_i$  the number of bits. Hence,  $x_{ik} = d_{ik}$  and  $X_i = T_i$ .

The output bit sequence corresponding to radio frame  $n_i$  is denoted by  $e_{i1}, e_{i2}, e_{i3}, \dots, e_{iN_i}$ , where  $i$  is the TrCH number and  $N_i$  is the number of bits. Hence,  $e_{i,k} = y_{i,n,k}$  and  $N_i = Y_i$ .

## 4.2.7 Rate matching

Rate matching means that bits on a TrCH are repeated or punctured. Higher layers assign a rate-matching attribute for each TrCH. This attribute is semi-static and can only be changed through higher layer signalling. The rate-matching attribute is used when the number of bits to be repeated or punctured is calculated.

The number of bits on a TrCH can vary between different transmission time intervals. When the number of bits between different transmission time intervals is changed, bits are repeated to ensure that the total bit rate after TrCH multiplexing is identical to the total channel bit rate of the allocated physical channels.

If no bits are input to the rate matching for all TrCHs within a CCTrCH, the rate matching shall output no bits for all TrCHs within the CCTrCH.

### Notation used in subclause 4.2.7 and subclauses:

$N_{i,j}$ : Number of bits in a radio frame before rate matching on TrCH  $i$  with transport format combination  $j$ .

$\Delta N_{i,j}$ : If positive – number of bits to be repeated in each radio frame on TrCH  $i$  with transport format combination  $j$ .

If negative – number of bits to be punctured in each radio frame on TrCH  $i$  with transport format combination  $j$ .

$RM_i$ : Semi-static rate matching attribute for TrCH  $i$ . Signalled from higher layers.

- PL*: Puncturing limit. This value limits the amount of puncturing that can be applied in order to minimise the number of physical channels. Signalled from higher layers.
- $N_{data,j}$ : Total number of bits that are available for a CCTrCH in a radio frame with transport format combination *j*.
- P*: number of physical channels used in the current frame.
- $P_{max}$ : maximum number of physical channels allocated for a CCTrCH.
- $U_p$ : Number of data bits in the physical channel *p* with  $p = 1 \dots P$ .
- I*: Number of TrCHs in a CCTrCH.
- $Z_{ij}$ : Intermediate calculation variable.
- $F_i$ : Number of radio frames in the transmission time interval of TrCH *i*.
- $n_i$ : Radio frame number in the transmission time interval of TrCH *i* ( $0 \leq n_i < F_i$ ).
- q*: Average puncturing or repetition distance (normalised to only show the remaining rate matching on top of an integer number of repetitions).

$\text{PI}_F(n_i)$ : The inverse interleaving column permutation function of the 1<sup>st</sup> interleaver. PI<sub>F</sub>(x) is the original position of column with number x after permutation. PI is defined on table 3 of section 4.2.5 (note that PI<sub>F</sub> the inverse interleaving function is identical to the interleaving function itself for the 1<sup>st</sup> interleaver self-inverse).

$S[n]S(n_i)$ : The shift of the puncturing or repetition pattern for radio frame  $n_i$  when  $n = \text{PI}_F(n_i)$ .

$T_F(i)T_F(j)$ : Transport format of TrCH *i* for the transport format combination *j*.

$TFS(i)TFS(i)$ : The set of transport format indexes *l* for TrCH *i*.

$e_{ini}$ : Initial value of variable *e* in the rate matching pattern determination algorithm of subclause 4.2.7.3.

$e_{plus}$ : Increment of variable *e* in the rate matching pattern determination algorithm of subclause 4.2.7.3.

$e_{minus}$ : Decrement of variable *e* in the rate matching pattern determination algorithm of subclause 4.2.7.3.

*b*: Indicates systematic and parity bits.

$b=1$ : Systematic bit.  $X(t)$  in subclause 4.2.3.2.1.

$b=2$ : 1<sup>st</sup> parity bit (from the upper Turbo constituent encoder).  $Y(t)$  in subclause 4.2.3.2.1.

$b=3$ : 2<sup>nd</sup> parity bit (from the lower Turbo constituent encoder).  $Y'(t)$  in subclause 4.2.3.2.1.

#### 4.2.7.1 Determination of rate matching parameters

The following relations, defined for all TFC *j*, are used when calculating the rate matching pattern:

$$Z_{0,j} = 0$$

$$Z_{i,j} = \left\lfloor \frac{\left( \left( \sum_{m=1}^i RM_m \times N_{m,j} \right) \times N_{data,j} \right)}{\sum_{m=1}^I RM_m \times N_{m,j}} \right\rfloor \quad Z_{ij} = \left\lfloor \frac{\left\{ \left( \sum_{m=1}^i RM_m \cdot N_{mj} \right) \cdot N_{data,j} \right\}}{\sum_{m=1}^I RM_m \cdot N_{mj}} \right\rfloor \quad \text{for all } i = 1 \dots H(1)$$

$$\Delta N_{i,j} = Z_{i,j} - Z_{i-1,j} - N_{i,j} \quad \Delta N_{ij} = Z_{ij} - Z_{i-1,j} - N_{ij} \quad \text{for all } i = 1 \dots H$$

Puncturing can be used to minimise the required transmission capacity. The maximum amount of puncturing that can be applied is signalled from higher layers and denoted by PL. The possible values for  $N_{data}$  depend on the number of physical channels  $P_{max}$ , allocated to the respective CCTrCH, and on their characteristics (spreading factor, length of midamble and TFCL, usage of TPC and multiframe structure), which is given in [7].

Denote the number of data bits in each physical channel by  $U_{p,Sp}$ , where  $p$  refers to the sequence number  $1 \leq p \leq P_{max}$  of this physical channel in the allocation message, and the second index  $Sp$  indicates the spreading factor with the possible values  $\{16, 8, 4, 2, 1\}$ , respectively. For each physical channel an individual minimum spreading factor  $Sp_{min}$  is transmitted by means of the higher layer. Then, for  $N_{data}$  one of the following values in ascending order can be chosen:

$$\{U_{1,16}, \dots, U_{1,Sp_{min}}, U_{1,Sp_{min}} + U_{2,16}, \dots, U_{1,Sp_{min}} + U_{2,Sp_{min}}, \dots, U_{1,Sp_{min}} + U_{2,Sp_{min}} + \dots + U_{P_{max},16}, \dots, U_{1,Sp_{min}} + U_{2,Sp_{min}} + \dots + U_{P_{max},(Sp_{max})_{min}}\}$$

$N_{data,j}$  for the transport format combination  $j$  is determined by executing the following algorithm:

SET1 = {  $N_{data}$  such that

$$\left( \min_{1 \leq y \leq I} \{RM_y\} \right) \times N_{data} - PL \times \sum_{x=1}^I RM_x \times N_{x,j} - \min_{1 \leq y \leq I} \{RM_y\} \times N_{data} - PL \times \sum_{x=1}^I RM_x \times N_{x,j} \text{ is non negative } \}$$

$N_{data,j} = \min \text{SET1}$

The number of bits to be repeated or punctured,  $\Delta N_{i,j} \Delta N_{i,j}$ , within one radio frame for each TrCH  $i$  is calculated with the relations given at the beginning of this subclause for all possible transport format combinations  $j$  and selected every radio frame.

If  $\Delta N_{i,j} \Delta N_{i,j} = 0$  then the output data of the rate matching is the same as the input data and the rate matching algorithm of subclause 4.2.7.3 does not need to be executed.

Otherwise, the rate matching pattern is calculated with the algorithm described in subclause 4.2.7.3. For this algorithm the parameters  $e_{mi}$ ,  $e_{plus}$ ,  $e_{minus}$ , and  $X_i$  are needed, which are calculated according to the equations in subclauses 4.2.7.1.1 and 4.2.7.1.2.

#### 4.2.7.1.1 Uncoded and convolutionally encoded TrCHs

$$a = 2$$

$$\Delta N_i = \Delta N_{i,j}$$

$$X_i = N_{i,j}$$

$$R = \frac{\Delta N_{i,j} \bmod N_{i,j} \Delta N_{i,j} \bmod N_{i,j}}{N_{i,j} N_{i,j} - 1} \text{ -- note: in this context } \frac{\Delta N_{i,j} \bmod N_{i,j} \Delta N_{i,j} \bmod N_{i,j}}{N_{i,j} N_{i,j} - 1} \text{ is in the range of 0 to } \frac{\Delta N_{i,j} \bmod N_{i,j} \Delta N_{i,j} \bmod N_{i,j}}{N_{i,j} N_{i,j} - 1} \text{ i.e. } -1 \bmod 10 = 9.$$

$$\text{if } R \neq 0 \text{ and } 2 \times R \leq \frac{N_{i,j} N_{i,j}}{R}$$

$$\text{then } q = \lceil \frac{N_{i,j} N_{i,j}}{R} \rceil$$

else

$$q = \lceil \frac{N_{i,j} N_{i,j}}{(R R - N_{i,j} N_{i,j})} \rceil$$

endif

NOTE 1:  $q$  is a signed quantity.

If  $q$  is even

$$\text{then } q' = q + \gcd(|q|, \frac{F_i - F_i}{F_i F_i}) / \frac{F_i - F_i}{F_i F_i} \text{ -- where } \gcd(|q|, \frac{F_i - F_i}{F_i F_i}) \text{ means greatest common divisor of } |q| \text{ and } \frac{F_i - F_i}{F_i F_i}$$

NOTE 2:  $q'$  is not an integer, but a multiple of 1/8.

else

$q' = q$

endif

for  $x = 0$  to  $F_i - F_i - 1$

$S[\lfloor \frac{x}{F_i} \rfloor \lfloor \lfloor x \times q' \rfloor \rfloor \bmod F_i - F_i] = (\lfloor x \times q' \rfloor \bmod F_i - F_i)$

end for

$e_{\text{int}} = (a \cdot S(n_i) \lfloor \Delta N_i \rfloor + 1) \bmod (a \cdot X_i)$ ;  $e_{\text{int}} = (a \times S[\lfloor \frac{P_1(n_i)}{F_i} \rfloor] \lfloor \Delta N_i \rfloor + 1) \bmod (a \cdot N_{i,j})$ .

$e_{\text{plus}} = a \cdot X_i$ ;  $e_{\text{plus}} = a \times X_i$

$e_{\text{minus}} = a \cdot \lfloor \Delta N_i \rfloor$ ;  $e_{\text{minus}} = a \times \lfloor \Delta N_i \rfloor$

puncturing for  $\Delta N_i / \Delta N_i < 0$ , repetition otherwise.

#### 4.2.7.1.2 Turbo encoded TrCHs

If repetition is to be performed on turbo encoded TrCHs, i.e.  $\Delta N_i > 0$ , the parameters in subclause 4.2.7.1.1 are used.

If puncturing is to be performed, the parameters below shall be used. Index  $b$  is used to indicate systematic ( $b=1$ ), 1<sup>st</sup> parity ( $b=2$ ), and 2<sup>nd</sup> parity bit ( $b=3$ ).

$a = 2$  when  $b=2$

$a = 1$  when  $b=3$

$$\Delta N_i = \begin{cases} \lfloor \Delta N_{i,j} / 2 \rfloor, & b = 2 \\ \lfloor \Delta N_{i,j} / 2 \rfloor, & b = 3 \end{cases}$$

If  $\Delta N_i$  is calculated as 0 for  $b=2$  or  $b=3$ , then the following procedure and the rate matching algorithm of subclause 4.2.7.3 don't need to be performed for the corresponding parity bit stream.

$X_i = \lfloor N_{i,j} / 3 \rfloor$ ,

$q = \lfloor X_i / \Delta N_i \rfloor$

if ( $q \leq 2$ )

for  $r=0$  to  $F_i - 1$

$S[\lfloor \frac{r}{F_i} \rfloor \lfloor (3 \times r + b - 1) \bmod F_i - F_i \rfloor] = r \bmod 2$ ;

end for

else

if  $q$  is even

then  $q' = q - \text{gcd}(q, F_i) / F_i$  -- where  $\text{gcd}(q, F_i)$  means greatest common divisor of  $q$  and  $F_i$

NOTE:  $q'$  is not an integer, but a multiple of 1/8.

else  $q' = q$

endif

for  $x=0$  to  $F_i - 1$

$r = \lfloor \frac{x}{F_i} \rfloor \lfloor x \times q' \rfloor \bmod F_i - F_i$ ;

$S[\lfloor \frac{r}{F_i} \rfloor \lfloor (3 \times r + b - 1) \bmod F_i - F_i \rfloor] = \lfloor \frac{x}{F_i} \rfloor \lfloor x \times q' \rfloor \bmod F_i - F_i$ ;

endfor  
endif

For each radio frame, the rate-matching pattern is calculated with the algorithm in subclause 4.2.7.3, where:

$X_j$  is as above,

$$e_{\text{minus}} - e_{\text{ini}} = (a \times \lfloor \frac{N_j}{N_i} \rfloor \times (n_j - \lfloor \Delta \frac{N_j}{N_i} \rfloor + X_j X_i) \bmod (a \times X_i), \text{ if } e_{\text{minus}} - e_{\text{ini}} = 0 \text{ then } e_{\text{minus}} = a \times X_i, e_{\text{ini}} = a \times X_j,$$

$$e_{\text{plus}} = a \times X_i, e_{\text{plus}} = a \times X_j$$

$$e_{\text{minus}} = a \times \lfloor \Delta \frac{N_j}{N_i} \rfloor, e_{\text{minus}} = a \times \lfloor \Delta \frac{N_j}{N_i} \rfloor$$

### 4.2.7.2 Bit separation and collection for rate matching

The systematic bits of turbo encoded TrCHs shall not be punctured, however systematic bits for trellis termination may be punctured. The systematic bits, first parity bits, and second parity bits in the bit sequence input to the rate matching block are therefore separated into three sequences, one sequence containing all of the systematic bits and some systematic, first and second parity trellis termination bits; the second sequence containing all of the first parity bits and some systematic, first and second parity trellis termination bits and the third sequence containing all of the second parity bits and some systematic, first and second parity trellis termination bits. Puncturing is only applied to the second and third sequences.

The bit separation function is transparent for uncoded TrCHs, convolutionally encoded TrCHs, and for turbo encoded TrCHs with repetition. The bit separation and bit collection are illustrated in figures 4 and 5.

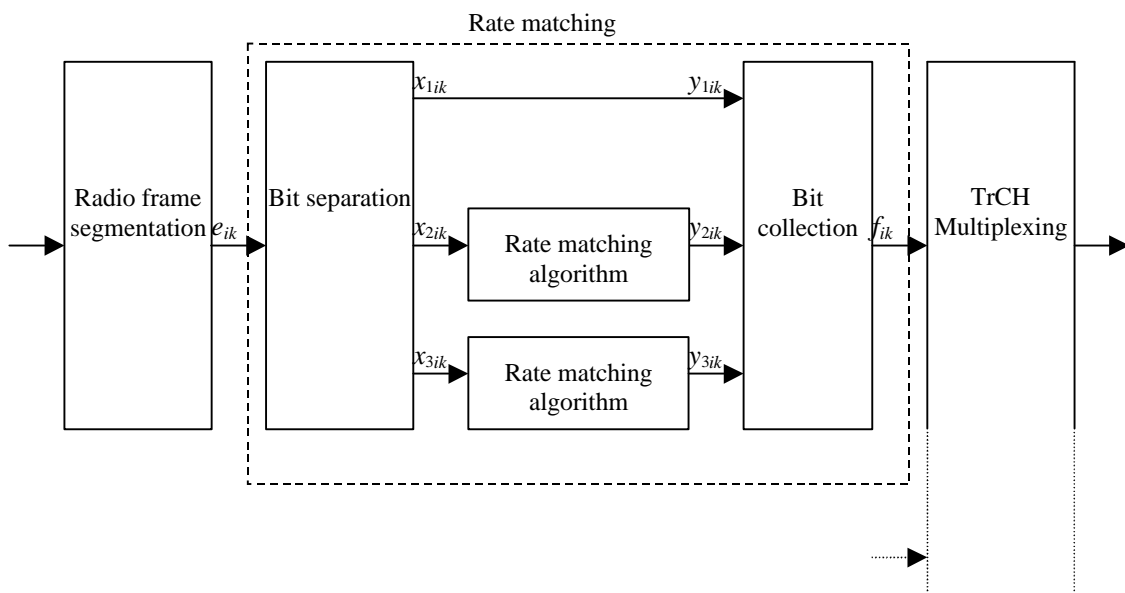
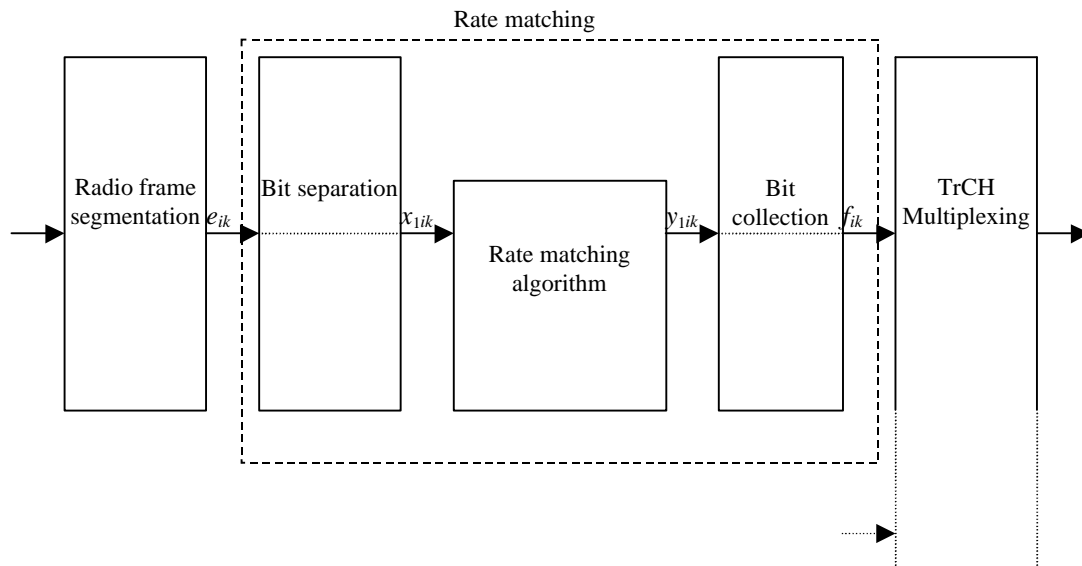

Figure 4: Puncturing of turbo encoded TrCHs



**Figure 5: Rate matching for uncoded TrCHs, convolutionally encoded TrCHs, and for turbo encoded TrCHs with repetition**

The bit separation is dependent on the 1<sup>st</sup> interleaving and offsets are used to define the separation for different TTIs. The sequence denoted as b=1 contains all of the systematic bits and some systematic, first and second parity trellis termination bits; the sequence denoted as b=2 contains all of the first parity bits and some systematic, first and second parity trellis termination bits; the sequence denoted as b=3 contains all of the second parity bits and some systematic, first and second parity trellis termination bits. The offsets  $a_b$  for these sequences are listed in table 4.

**Table 4: TTI dependent offset needed for bit separation**

TTI (ms)	$a_1$	$a_2$	$a_3$
10, 40	0	1	2
20, 80	0	2	1

The bit separation is different for different radio frames in the TTI. A second offset is therefore needed. The radio frame number for TrCH  $i$  is denoted by  $n_i$ , and the offset by  $b_{n_i}$ .

**Table 5: Radio frame dependent offset needed for bit separation**

TTI (ms)	$b_0$	$b_1$	$b_2$	$b_3$	$b_4$	$b_5$	$b_6$	$b_7$
10	0	NA	NA	NA	NA	NA	NA	NA
20	0	1	NA	NA	NA	NA	NA	NA
40	0	1	2	0	NA	NA	NA	NA
80	0	1	2	0	1	2	0	1

4.2.7.2.1 Bit separation

The bits input to the rate matching are denoted by  $e_{i,1}, e_{i,2}, e_{i,3}, \dots, e_{i,N_i}$ , where  $i$  is the TrCH number and  $N_i$  is the number of bits input to the rate matching block. Note that the transport format combination number  $j$  for simplicity has been left out in the bit numbering, i.e.  $N_i = N_{i,j}$ . The bits after separation are denoted by  $x_{b,i,1}, x_{b,i,2}, x_{b,i,3}, \dots, x_{b,i,X_i}$ . For turbo encoded TrCHs with puncturing,  $b$  indicates the three sequences defined in section 4.2.7.2. The sequence denoted as  $b=1$  contains all of the systematic bits and some systematic, first and second parity trellis termination bits; the sequence denoted as  $b=2$  contains all of the first parity bits and some systematic, first and second parity trellis termination bits; the sequence denoted as  $b=3$  contains all of the second parity bits and some systematic, first and second parity trellis termination bits. For all other cases  $b$  is defined to be 1.  $X_i$  is the number of bits in each separated bit sequence. The relation between  $e_{i,k}$  and  $x_{b,i,k}$  is given below.



For turbo encoded TrCHs with puncturing:

$$\begin{aligned}
 x_{1,i,k} &= e_{i,3(k-1)+1+(a_1+b_{n_i}) \bmod 3} & k = 1, 2, 3, \dots, X_i & & X_i = \lfloor N_i / 3 \rfloor \\
 x_{1,i,\lfloor N_i / 3 \rfloor + k} &= e_{i,3\lfloor N_i / 3 \rfloor + k} & k = 1, \dots, N_i \bmod 3 & & \text{Note: When } (N_i \bmod 3) = 0 \text{ this row is not needed.} \\
 x_{2,i,k} &= e_{i,3(k-1)+1+(a_2+b_{n_i}) \bmod 3} & k = 1, 2, 3, \dots, X_i & & X_i = \lfloor N_i / 3 \rfloor \\
 x_{3,i,k} &= e_{i,3(k-1)+1+(a_3+b_{n_i}) \bmod 3} & k = 1, 2, 3, \dots, X_i & & X_i = \lfloor N_i / 3 \rfloor
 \end{aligned}$$

For uncoded TrCHs, convolutionally encoded TrCHs, and turbo encoded TrCHs with repetition:

$$x_{1,i,k} = e_{i,k} \quad k = 1, 2, 3, \dots, X_i \quad X_i = N_i$$

#### 4.2.7.2.2 Bit collection

The bits  $x_{b,i,k}$  are input to the rate matching algorithm described in subclause 4.2.7.3. The bits output from the rate matching algorithm are denoted  $y_{b,i,1}, y_{b,i,2}, y_{b,i,3}, \dots, y_{b,i,Y_i}$   ~~$y_{bi1}, y_{bi2}, y_{bi3}, \dots, y_{biY_i}$~~ .

Bit collection is the inverse function of the separation. The bits after collection are denoted by

$z_{b,i,1}, z_{b,i,2}, z_{b,i,3}, \dots, z_{b,i,Y_i}$   ~~$z_{bi1}, z_{bi2}, z_{bi3}, \dots, z_{biY_i}$~~ . After bit collection, the bits indicated as punctured are removed and the bits are then denoted by  $f_{i,1}, f_{i,2}, f_{i,3}, \dots, f_{i,V_i}$   ~~$f_{i1}, f_{i2}, f_{i3}, \dots, f_{iV_i}$~~ , where  $i$  is the TrCH number and  $V_i = \lfloor \frac{N_i + \Delta N_i - N_{i,j} + DN_{i,j}}{3} \rfloor$ . The relations between  ~~$y_{b,i,k}, z_{b,i,k}, y_{b,i,k}, z_{b,i,k}$~~  and  ~~$f_{i,k}, f_{i,k}$~~  are given below.

For turbo encoded TrCHs with puncturing ( $Y_i = X_i$ ):

$$\begin{aligned}
 z_{i,3(k-1)+1+(a_1+b_{n_i}) \bmod 3} &= y_{1,i,k} & k = 1, 2, 3, \dots, Y_i \\
 z_{i,3\lfloor N_i / 3 \rfloor + k} &= y_{1,i,\lfloor N_i / 3 \rfloor + k} & k = 1, \dots, N_i \bmod 3 & & \text{Note: When } (N_i \bmod 3) = 0 \text{ this row is not needed.} \\
 z_{i,3(k-1)+1+(a_2+b_{n_i}) \bmod 3} &= y_{2,i,k} & k = 1, 2, 3, \dots, Y_i \\
 z_{i,3(k-1)+1+(a_3+b_{n_i}) \bmod 3} &= y_{3,i,k} & k = 1, 2, 3, \dots, Y_i
 \end{aligned}$$

After the bit collection, bits  $z_{i,k}$  with value  $d$ , where  $d \in \{0, 1\}$ , are removed from the bit sequence. Bit  $f_{i,1}$  corresponds to the bit  $z_{i,k}$  with smallest index  $k$  after puncturing, bit  $f_{i,2}$  corresponds to the bit  $z_{i,k}$  with second smallest index  $k$  after puncturing, and so on.

For uncoded TrCHs, convolutionally encoded TrCHs, and turbo encoded TrCHs with repetition:

$$z_{i,k} = y_{1,i,k} \quad k = 1, 2, 3, \dots, Y_i$$

When repetition is used,  $f_{i,k} = z_{i,k}$  and  $Y_i = V_i$ .

When puncturing is used,  $Y_i = X_i$  and bits  $z_{i,k}$  with value  $d$ , where  $d \in \{0, 1\}$ , are removed from the bit sequence. Bit  $f_{i,1}$  corresponds to the bit  $z_{i,k}$  with smallest index  $k$  after puncturing, bit  $f_{i,2}$  corresponds to the bit  $z_{i,k}$  with second smallest index  $k$  after puncturing, and so on.

#### 4.2.7.3 Rate matching pattern determination

The bits input to the rate matching are denoted by  $x_{i,1}, x_{i,2}, x_{i,3}, \dots, x_{i,X_i}$   ~~$x_{i1}, x_{i2}, x_{i3}, \dots, x_{iX_i}$~~ , where  $i$  is the TrCH and  $X_i$  is the parameter given in subclauses 4.2.7.1.1 and 4.2.7.1.2.

NOTE: The transport format combination number  $j$  for simplicity has been left out in the bit numbering.

The rate matching rule is as follows:

if puncturing is to be performed

$e_e = e_{mi} e_{ini}$  -- initial error between current and desired puncturing ratio

$m = 1$  -- index of current bit

do while  $m \leq X_i$

$e_e = e_e - e_{minus} e_{minus}$  -- update error

if  $e \leq 0$  then -- check if bit number  $m$  should be punctured

set bit  $x_{i,m}$  to  $d$  where  $d \in \{0, 1\}$

$e_e = e_e + e_{plus} e_{plus}$  -- update error

end if

$m = m + 1$  -- next bit

end do

else

$e = e_{im} e_{mi}$  -- initial error between current and desired puncturing ratio

$m = 1$  -- index of current bit

do while  $m \leq X_i$

$e_e = e_e - e_{minus} e_{minus}$  -- update error

do while  $e \leq 0$  -- check if bit number  $m$  should be repeated

repeat bit  $x_{i,m}$

$e_e = e_e + e_{plus} e_{plus}$  -- update error

end do

$m = m + 1$  -- next bit

end do

end if

A repeated bit is placed directly after the original one.

## 4.2.8 TrCH multiplexing

Every 10 ms, one radio frame from each TrCH is delivered to the TrCH multiplexing. These radio frames are serially multiplexed into a coded composite transport channel (CCTrCH).

The bits input to the TrCH multiplexing are denoted by  $f_{i,1}, f_{i,2}, f_{i,3}, \dots, f_{i,V_i}, f_{i,1}, f_{i,2}, f_{i,3}, \dots, f_{i,V_i}$ , where  $i$  is the TrCH number and  $V_i$  is the number of bits in the radio frame of TrCH  $i$ . The number of TrCHs is denoted by  $I$ . The bits output from TrCH multiplexing are denoted by  $s_1, s_2, s_3, \dots, s_S$ , where  $S$  is the number of bits, i.e.  $S = \sum_i V_i$ . The

TrCH multiplexing is defined by the following relations:

$$s_k = f_{1,k} \quad s_k = f_{1k} \quad k = 1, 2, \dots, V_1$$

$$s_k = f_{2,(k-V_1)} \quad k = V_1+1, V_1+2, \dots, V_1+V_2$$

$$s_k = f_{3,(k-(V_1+V_2))} \quad k = (V_1+V_2)+1, (V_1+V_2)+2, \dots, (V_1+V_2)+V_3$$

...

$$s_k = f_{L,(k-(V_1+V_2+\dots+V_{L-1}))} \quad k = (V_1+V_2+\dots+V_{L-1})+1, (V_1+V_2+\dots+V_{L-1})+2, \dots, (V_1+V_2+\dots+V_{L-1})+V_L$$

## 4.2.9 Physical channel segmentation

When more than one PhCH is used, physical channel segmentation divides the bits among the different PhCHs. The bits input to the physical channel segmentation are denoted by  $s_1, s_2, s_3, \dots, s_S$ , where  $S$  is the number of bits input to the physical channel segmentation block. The number of PhCHs is denoted by  $P$ .

The bits after physical channel segmentation are denoted  $u_{p,1}, u_{p,2}, u_{p,3}, \dots, u_{p,U_p}$ , where  $p$  is PhCH number and  $U_p$  is the in general variable number of bits in the respective radio frame for each PhCH. The relation between  $s_k$  and  $u_{p,k}$  is given below.

Bits on first PhCH after physical channel segmentation:

$$u_{1k} = s_k \quad u_{1,k} = s_k \quad k = 1, 2, \dots, U_1$$

Bits on second PhCH after physical channel segmentation:

$$u_{2k} = s_{(k+U_1)} \quad u_{2,k} = s_{(k+U_1)} \quad k = 1, 2, \dots, U_2$$

...

Bits on the  $P^{\text{th}}$  PhCH after physical channel segmentation:

$$u_{Pk} = s_{(k+U_1+\dots+U_{P-1})} \quad u_{P,k} = s_{(k+U_1+\dots+U_{P-1})} \quad k = 1, 2, \dots, U_P$$

## 4.2.10 2nd interleaving

The 2nd interleaving can be applied jointly to all data bits transmitted during one frame, or separately within each timeslot, on which the CCTrCH is mapped. The selection of the 2nd interleaving scheme is controlled by higher layer.

### 4.2.10.1 Frame related 2nd interleaving

In case of frame related interleaving, the bits input to the 2<sup>nd</sup> interleaver are denoted  $x_1, x_2, x_3, \dots, x_U$ , where  $U$  is the total number of bits after TrCH multiplexing transmitted during the respective radio frame with  $S=U = \sum_P U_p$ .

The relation between  $x_k$  and the bits  $u_{p,k}$  in the respective physical channels is given below:

$$x_k = u_{1k} \quad x_k = u_{1,k} \quad k = 1, 2, \dots, U_1$$

$$x_{(k+U_1)} = u_{2k} \quad x_{(k+U_1)} = u_{2,k} \quad k = 1, 2, \dots, U_2$$

...

$$x_{(k+U_1+\dots+U_{P-1})} = u_{Pk} \quad x_{(k+U_1+\dots+U_{P-1})} = u_{P,k} \quad k = 1, 2, \dots, U_P$$

The following steps have to be performed once for each CCTrCH:

- (1) Set the number of columns  $C_2 = 30$ . The columns are numbered 0, 1, 2, ...,  $C_2-1$  from left to right.

(2) Determine the number of rows  $R_2-R2$  by finding minimum integer  $R_2-R2$  such that:

$$U \leq R_2 \cdot C_2 \cdot R2 \times C2.$$

(3) The bits input to the 2<sup>nd</sup> interleaving are written into the  $R_2-R2 \times C_2-C2$  rectangular matrix row by row.

$$\begin{bmatrix} x_1 & x_2 & x_3 & \dots & x_{30} \\ x_{31} & x_{32} & x_{33} & \dots & x_{60} \\ \vdots & \vdots & \vdots & \dots & \vdots \\ x_{(R2-1) \times 30 + 1} & x_{(R2-1) \times 30 + 2} & x_{(R2-1) \times 30 + 3} & \dots & x_{R2 \times 30} \end{bmatrix} \begin{bmatrix} x_1 & x_2 & x_3 & \dots & x_{30} \\ x_{31} & x_{32} & x_{33} & \dots & x_{60} \\ \vdots & \vdots & \vdots & \dots & \vdots \\ x_{(R2-1) \times 30 + 1} & x_{(R2-1) \times 30 + 2} & x_{(R2-1) \times 30 + 3} & \dots & x_{R2 \times 30} \end{bmatrix}$$

4) Perform the inter-column permutation based on the pattern  $\{P_2P2(j)\}$  ( $j = 0, 1, \dots, C_2-C2-1$ ) that is shown in table 6, where  $P_2P2(j)$  is the original column position of the j-th permuted column. After permutation of the columns, the bits are denoted by  $y_k$ .

$$\begin{bmatrix} y_1 & y_{R2+1} & y_{2 \times R2+1} & \dots & y_{29 \times R2+1} \\ y_2 & y_{R2+2} & y_{2 \times R2+2} & \dots & y_{29 \times R2+2} \\ \vdots & \vdots & \vdots & \dots & \vdots \\ y_{R2} & y_{2 \times R2} & y_{3 \times R2} & \dots & y_{30 \times R2} \end{bmatrix} \begin{bmatrix} y_1 & y_{R2+1} & y_{2R2+1} & \dots & y_{29R2+1} \\ y_2 & y_{R2+2} & y_{2R2+2} & \dots & y_{29R2+2} \\ \vdots & \vdots & \vdots & \dots & \vdots \\ y_{R2} & y_{2R2} & y_{3R2} & \dots & y_{30R2} \end{bmatrix}$$

(5) The output of the 2<sup>nd</sup> interleaving is the bit sequence read out column by column from the inter-column permuted  $R_2-R2 \times C_2-C2$  matrix. The output is pruned by deleting bits that were not present in the input bit sequence, i.e. bits  $y_k$  that corresponds to bits  $x_k$  with  $k > U$  are removed from the output. The bits after 2<sup>nd</sup> interleaving are denoted by  $v_1, v_2, \dots, v_U$ , where  $v_1$  corresponds to the bit  $y_k$  with smallest index  $k$  after pruning,  $v_2$  to the bit  $y_k$  with second smallest index  $k$  after pruning, and so on.

#### 4.2.10.2 Timeslot related 2<sup>nd</sup> interleaving

In case of timeslot related 2<sup>nd</sup> interleaving, the bits input to the 2<sup>nd</sup> interleaver are denoted  $x_{t,1}, x_{t,2}, x_{t,3}, \dots, x_{t,U_t}$ , where  $t$  refers to a certain timeslot, and  $U_t$  is the number of bits transmitted in this timeslot during the respective radio frame.

In each timeslot  $t$  the relation between  $x_{t,k}$  and  $u_{t,p,k}$  is given below with  $P_t$  referring to the number of physical channels within the respective timeslot:

$$x_{t,k} = u_{t,1,k} \quad k = 1, 2, \dots, U_{t1}$$

$$x_{t,(k+U_{t1})} = u_{t,2,k} \quad k = 1, 2, \dots, U_{t2}$$

...

$$x_{t,(k+U_{t1}+\dots+U_{t(P_t-1)})} = u_{t,P_t,k} \quad k = 1, 2, \dots, U_{tP_t}$$

The following steps have to be performed for each timeslot  $t$ , on which the respective CCTrCH is mapped:

- (1) Set the number of columns  $C_2-C2 = 30$ . The columns are numbered 0, 1, 2, ...,  $C_2-C2-1$  from left to right.
- (2) Determine the number of rows  $R_2-R2$  by finding minimum integer  $R_2-R2$  such that:

$$U_t \leq R_2 \cdot C_2 \cdot R2 \times C2.$$

- (3) The bits input to the 2<sup>nd</sup> interleaving are written into the  $R_2-R2 \times C_2-C2$  rectangular matrix row by row.

$$\begin{bmatrix} x_{t,1} & x_{t,2} & x_{t,3} & \dots & x_{t,30} \\ x_{t,31} & x_{t,32} & x_{t,33} & \dots & x_{t,60} \\ \vdots & \vdots & \vdots & \dots & \vdots \\ x_{t,((R_2-1)\times 30+1)} & x_{t,((R_2-1)\times 30+2)} & x_{t,((R_2-1)\times 30+3)} & \dots & x_{t,(R_2\times 30)} \end{bmatrix}$$

---

$$\begin{bmatrix} x_{t,1} & x_{t,2} & x_{t,3} & \dots & x_{t,30} \\ x_{t,31} & x_{t,32} & x_{t,33} & \dots & x_{t,60} \\ \vdots & \vdots & \vdots & \dots & \vdots \\ x_{t,((R_2-1)\times 30+1)} & x_{t,((R_2-1)\times 30+2)} & x_{t,((R_2-1)\times 30+3)} & \dots & x_{t,(R_2\times 30)} \end{bmatrix}$$

(4) Perform the inter-column permutation based on the pattern  $\{P_2(j)-P_2(j) \mid j = 0, 1, \dots, C_2-1\}$  that is shown in table 6, where  $P_2(j)-P_2(j)$  is the original column position of the  $j$ -th permuted column. After permutation of the columns, the bits are denoted by  $y_{t,k}$ .

$$\begin{bmatrix} y_{t,1} & y_{t,(R_2+1)} & y_{t,(2\times R_2+1)} & \dots & y_{t,(29\times R_2+1)} \\ y_{t,2} & y_{t,(R_2+2)} & y_{t,(2\times R_2+2)} & \dots & y_{t,(29\times R_2+2)} \\ \vdots & \vdots & \vdots & \dots & \vdots \\ y_{t,R_2} & y_{t,(2\times R_2)} & y_{t,(3\times R_2)} & \dots & y_{t,(30\times R_2)} \end{bmatrix} \begin{bmatrix} y_{t,1} & y_{t,(R_2+1)} & y_{t,(2R_2+1)} & \dots & y_{t,(29R_2+1)} \\ y_{t,2} & y_{t,(R_2+2)} & y_{t,(2R_2+2)} & \dots & y_{t,(29R_2+2)} \\ \vdots & \vdots & \vdots & \dots & \vdots \\ y_{t,R_2} & y_{t,(2R_2)} & y_{t,(3R_2)} & \dots & y_{t,(30R_2)} \end{bmatrix}$$

(5) The output of the 2<sup>nd</sup> interleaving is the bit sequence read out column by column from the inter-column permuted  $R_2 \times C_2$  matrix. The output is pruned by deleting bits that were not present in the input bit sequence, i.e. bits  $y_{t,k}$  that corresponds to bits  $x_{t,k}$  with  $k > U_t$  are removed from the output. The bits after 2<sup>nd</sup> interleaving are denoted by  $v_{t,1}, v_{t,2}, \dots, v_{t,U_t}$ , where  $v_{t,1}$  corresponds to the bit  $y_{t,k}$  with smallest index  $k$  after pruning,  $v_{t,2}$  to the bit  $y_{t,k}$  with second smallest index  $k$  after pruning, and so on.

Table 6

Column number $C_2$	Inter-column permutation pattern $\langle P_2(0), P_2(1), \dots, P_2(29) \rangle$
30	$\langle 0, 20, 10, 5, 15, 25, 3, 13, 23, 8, 18, 28, 1, 11, 21, 6, 16, 26, 4, 14, 24, 19, 9, 29, 12, 2, 7, 22, 27, 17 \rangle$

### 4.2.11 Physical channel mapping

The PhCH for both uplink and downlink is defined in [6]. The bits after physical channel mapping are denoted by  $w_{p,1}, w_{p,2}, \dots, w_{p,U_p}$ , where  $p$  is the PhCH number and  $U_p$  is the number of bits in one radio frame for the respective PhCH. The bits  $w_{p,k}$  are mapped to the PhCHs so that the bits for each PhCH are transmitted over the air in ascending order with respect to  $k$ .

The mapping of the bits  $v_{(t),1}, v_{(t),2}, \dots, v_{(t),U_t}$  is performed like block interleaving, writing the bits into columns, but a PhCH with an odd number is filled in forward order, were as a PhCH with an even number is filled in reverse order.

The mapping scheme, as described in the following subclause, shall be applied individually for each timeslot  $t$  used in the current frame. Therefore, the bits  $v_{t,1}, v_{t,2}, \dots, v_{t,U_t}$  are assigned to the bits of the physical channels

$$w_{t,1,1 \dots U_{t1}}, w_{t,2,1 \dots U_{t2}}, \dots, w_{t,P_t,1 \dots U_{tP_t}}$$

In uplink there are at most two codes allocated ( $P \leq 2$ ). If there is only one code, the same mapping as for downlink is applied. Denote SF1 and SF2 the spreading factors used for code 1 and 2, respectively. For the number of consecutive bits to assign per code  $bs_k$  the following rule is applied:

if

SF1  $\geq$  SF2 then  $bs_1 = 1$  ;  $bs_2 = SF1/SF2$  ;

else

SF2  $>$  SF1 then  $bs_1 = SF2/SF1$ ;  $bs_2 = 1$  ;

end if

In the downlink case  $bs_p$  is 1 for all physical channels.

#### 4.2.11.1 Mapping scheme

Notation used in this subclause:

$P_t$ : number of physical channels for timeslot t ,  $P_t = 1..2$  for uplink ;  $P_t = 1..16$  for downlink

$U_{t,p}$ : capacity in bits for the physical channel p in timeslot t

$U_t$ : total number of bits to be assigned for timeslot t

$bs_p$ : number of consecutive bits to assign per code

for downlink all  $bs_p = 1$

for uplink if SF1  $\geq$  SF2 then  $bs_1 = 1$  ;  $bs_2 = SF1/SF2$  ;

if SF2  $>$  SF1 then  $bs_1 = SF2/SF1$ ;  $bs_2 = 1$  ;

$fb_p$ : number of already written bits for each code

pos: intermediate calculation variable

for p=1 to  $P_t$  -- reset number of already written bits for every physical channel

$fb_p = 0$

end for

p = 1 -- start with PhCH #1

for k=1 to  $U_t$

do while ( $fb_p == U_{t,p}$ ) -- physical channel filled up already ?

p = (p mod  $P_t$ ) + 1;

end do

if (p mod 2) == 0

pos =  $U_{t,p} - U_{t,p} - fb_p$  -- reverse order

else

pos =  $fb_p + 1$  -- forward order

endif

$W_{t,p, pos} = v_{t,k}$  -- assignment

$fb_p = fb_p + 1$  -- Increment number of already written bits

if  $(fb_p \bmod bs_p) == 0$

-- Conditional change to the next physical channel

$p = (p \bmod P_t) + 1;$

## 4.3 Coding for layer 1 control

### 4.3.1 Coding of transport format combination indicator (TFCI)

Encoding of the TFCI bits depends on the number of the bits length. If there are 6-10 bits of TFCI the channel encoding is done as described in subclause 4.3.1.1. Also specific coding of less than 6 bits is possible as explained in subclause 4.3.1.2.

#### 4.3.1.1 Coding of long TFCI lengths

The TFCI bits are encoded using a (32, 10) sub-code of the second order Reed-Muller code. The coding procedure is as shown in figure 6.

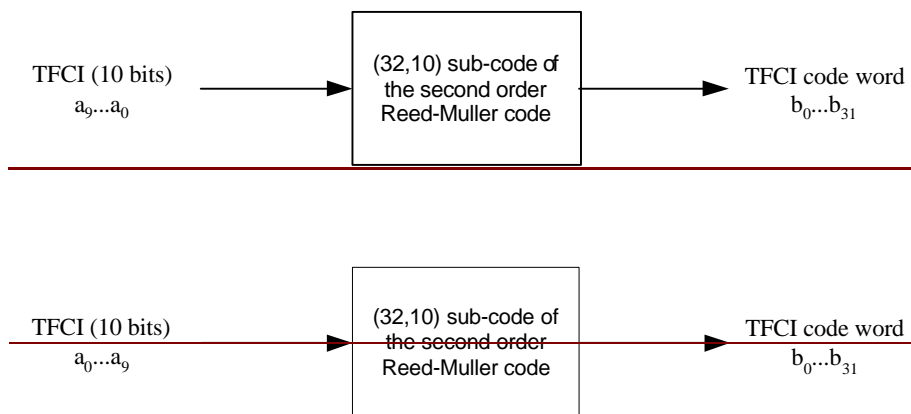

**Figure 6: Channel coding of TFCI information bits**

TFCI is encoded by the (32,10) sub-code of second order Reed-Muller code. The code words of the (32,10) sub-code of second order Reed-Muller code are linear combination of some among 10 basis sequences. The basis sequences are as follows in table 7.



Table 7: Basis sequences for (32,10) TFCI code

I	M <sub>i,0</sub>	M <sub>i,1</sub>	M <sub>i,2</sub>	M <sub>i,3</sub>	M <sub>i,4</sub>	M <sub>i,5</sub>	M <sub>i,6</sub>	M <sub>i,7</sub>	M <sub>i,8</sub>	M <sub>i,9</sub>
0	1	0	0	0	0	1	0	0	0	0
1	0	1	0	0	0	1	1	0	0	0
2	1	1	0	0	0	1	0	0	0	1
3	0	0	1	0	0	1	1	0	1	1
4	1	0	1	0	0	1	0	0	0	1
5	0	1	1	0	0	1	0	0	1	0
6	1	1	1	0	0	1	0	1	0	0
7	0	0	0	1	0	1	0	1	1	0
8	1	0	0	1	0	1	1	1	1	0
9	0	1	0	1	0	1	1	0	1	1
10	1	1	0	1	0	1	0	0	1	1
11	0	0	1	1	0	1	0	1	1	0
12	1	0	1	1	0	1	0	1	0	1
13	0	1	1	1	0	1	1	0	0	1
14	1	1	1	1	0	1	1	1	1	1
15	1	0	0	0	1	1	1	1	0	0
16	0	1	0	0	1	1	1	1	0	1
17	1	1	0	0	1	1	1	0	1	0
18	0	0	1	0	1	1	0	1	1	1
19	1	0	1	0	1	1	0	1	0	1
20	0	1	1	0	1	1	0	0	1	1
21	1	1	1	0	1	1	0	1	1	1
22	0	0	0	1	1	1	0	1	0	0
23	1	0	0	1	1	1	1	1	0	1
24	0	1	0	1	1	1	1	0	1	0
25	1	1	0	1	1	1	1	0	0	1
26	0	0	1	1	1	1	0	0	1	0
27	1	0	1	1	1	1	1	1	0	0
28	0	1	1	1	1	1	1	1	1	0
29	1	1	1	1	1	1	1	1	1	1
30	0	0	0	0	0	1	0	0	0	0
31	0	0	0	0	1	1	1	0	0	0

Let's define the TFCI information bits as  $a_0, a_1, a_2, a_3, a_4, a_5, a_6, a_7, a_8, a_9$  (where  $a_0$  is LSB and  $a_9$  is MSB). The TFCI information bits shall correspond to the TFC index (expressed in unsigned binary form) defined by the RRC layer to reference the TFC of the CCTrCH in the associated DPCH radio frame.

The output code word bits  $b_i$  are given by:

$$b_i = \sum_{n=0}^9 (a_n \times M_{i,n}) \bmod 2$$

where  $i=0, \dots, 31$ .  $N_{\text{TFCI}}=32$ .

#### 4.3.1.2 Coding of short TFCI lengths

##### 4.3.1.2.1 Coding very short TFCIs by repetition

If the number of TFCI bits is 1 or 2, then repetition will be used for coding. In this case each bit is repeated to a total of 4 times giving 4-bit transmission ( $N_{\text{TFCI}}=4$ ) for a single TFCI bit and 8-bit transmission ( $N_{\text{TFCI}}=8$ ) for 2 TFCI bits. Let's define the TFCI information bit(s) as  $b_0$  (or  $b_0$  and  $b_1$ ). The TFCI information bit(s)  $b_0$  (or  $b_0$  and  $b_1$  where  $b_0$  is the LSB) shall correspond to the TFC index (expressed in unsigned binary form) defined by the RRC layer to reference the TFC of the CCTrCH in the associated DPCH radio frame. In the case of two TFCI bits denoted  $b_0$  and  $b_1$  the TFCI word shall be  $\{ b_0, b_1, b_0, b_1, b_0, b_1, b_0, b_1 \}$ .

##### 4.3.1.2.2 Coding short TFCIs using bi-orthogonal codes

If the number of TFCI bits is in the range 3 to 5 the TFCI bits are encoded using a (16, 5) bi-orthogonal (or first order Reed-Muller) code. The coding procedure is as shown in figure 7.

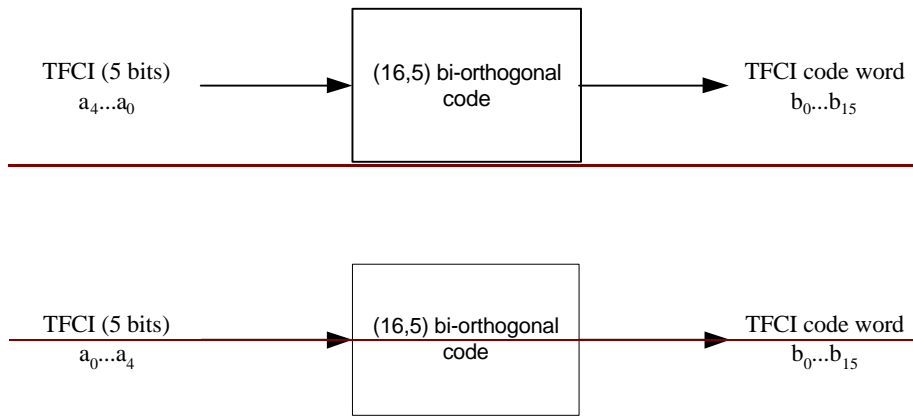

Figure 7: Channel coding of short length TFCI [information bits](#)

The code words of the (16,5) bi-orthogonal code are linear combinations of 5 basis sequences as defined in table 8.

Table 8: Basis sequences for (16,5) TFCI code

i	M <sub>i,0</sub>	M <sub>i,1</sub>	M <sub>i,2</sub>	M <sub>i,3</sub>	M <sub>i,4</sub>
0	1	0	0	0	1
1	0	1	0	0	1
2	1	1	0	0	1
3	0	0	1	0	1
4	1	0	1	0	1
5	0	1	1	0	1
6	1	1	1	0	1
7	0	0	0	1	1
8	1	0	0	1	1
9	0	1	0	1	1
10	1	1	0	1	1
11	0	0	1	1	1
12	1	0	1	1	1
13	0	1	1	1	1
14	1	1	1	1	1
15	0	0	0	0	1

~~Let's define t~~The TFCI information bits ~~as~~  $a_0, a_1, a_2, a_3, a_4$  (where  $a_0$  is LSB and  $a_4$  is MSB). ~~The TFCI information bits~~ shall correspond to the TFC index (expressed in unsigned binary form) defined by the RRC layer to reference the TFC of the CCTrCH in the associated DPCH radio frame.

The output code word bits  $b_j$  are given by:

$$b_i = \sum_{n=0}^4 (a_n \times M_{i,n}) \bmod 2$$

where  $i=0, \dots, 15$ .  $N_{\text{TFCI}}=16$ .