

3GPP RAN 25.214 V1.1.2 (1999-08)

Technical Specification

**3rd Generation Partnership Project (3GPP);
Technical Specification Group (TSG)
Radio Access Network (RAN);
Working Group 1 (WG1);
Physical layer procedures (FDD)**



Reference

<Workitem>

Keywords

<keyword[, keyword]>

3GPP

Postal address

Office address

Internet

<http://www.3gpp.org>

Copyright Notification

Reproduction is only permitted for the purpose of standardization work undertaken within 3GPP.
The copyright and the foregoing restrictions extend to reproduction in all media.

© 3GPP 1999.
All rights reserved.

Contents

Contents	3
Intellectual Property Rights	5
Foreword	5
1 Scope	5
2 References	5
3 Definitions, symbols and abbreviations	5
3.1 Definitions	5
3.2 Symbols.....	5
3.3 Abbreviations.....	6
4 Synchronisation procedures.....	6
4.1 Cell search	6
4.2 Primary CCPCH synchronisation.....	7
4.3 Secondary CCPCH synchronisation.....	7
4.4 PRACH synchronisation	7
4.5 DPCCH/DPDCH synchronisation.....	7
4.5.1 General	7
4.5.2 No existing uplink dedicated channel.....	7
4.5.3 With existing uplink dedicated channel.....	8
5 Power control.....	10
5.1 Uplink power control	10
5.1.1 PRACH	10
5.1.2 DPCCH/DPDCH.....	10
5.1.2.1 General	10
5.1.2.2 Ordinary transmit power control.....	10
5.1.2.2.1 General.....	10
5.1.2.2.1.1 Algorithm 1	11
5.1.2.2.1.2 Algorithm 2	11
5.1.2.2.1.3 Out of synchronisation handling	11
5.1.2.2.2 Combining of TPC commands known to be the same.....	12
5.1.2.2.3 Combining of TPC commands not known to be the same.....	12
5.1.2.2.3.1 General scheme	12
5.1.2.2.3.2 Example of the scheme.....	13
5.1.2.3 Transmit power control in compressed mode	13
5.2 Downlink power control	14
5.2.1 Primary CCPCH.....	14
5.2.2 Secondary CCPCH.....	14
5.2.3 DPCCH/DPDCH.....	14
5.2.3.1 General	14
5.2.3.2 Ordinary transmit power control.....	14
5.2.3.3 Power control in compressed mode	16
5.2.3.4 Slow transmit power control.....	17
5.2.3.5 Site selection diversity transmit power control	17
5.2.3.5.1 General.....	17
5.2.3.5.2 Initiation of SSDT.....	17
5.2.3.5.3 Settings of temporary cell identification	17
5.2.3.5.3.1 Definition of temporary cell identification	18
5.2.3.5.3.2 Assignment of ID to each cell.....	19
5.2.3.5.3.3 Notification of ID assignment change	19
5.2.3.5.4 TPC procedure in UE.....	19
5.2.3.5.5 Selection of primary cell	19

5.2.3.5.6	Delivery of primary cell ID	19
5.2.3.5.7	TPC procedure in the network	20
5.2.3.5.7.1	Management of multiple transmission power levels	20
5.2.3.5.7.2	Power setting of the downlink Dedicated Physical Channel.....	20
5.2.3.5.8	Termination of SSDT	21
5.2.4	Power Control with DSCH.....	21
6	Random access procedure	21
7	Transmission stop and resumption control.....	23
7.1	General.....	24
7.2	Transmission stop control	24
7.2.1	Network control procedure.....	24
7.2.2	UE control procedure	24
7.2.3	Illustration of network and UE procedures.....	24
7.3	Transmission resumption control	25
7.3.1	Network control procedure.....	25
7.3.2	UE control procedure	25
7.3.3	Illustration of network and UE procedures.....	26
8	Feedback mode transmit diversity	27
8.1	DPCH transmission scheme	27
8.2	Uplink signaling channel.....	27
8.3	Determination of feedback information	29
9	Reverse link synchronous transmission.....	30
9.1	General.....	30
9.2	Initial synchronisation	30
9.3	Tracking process	31
9.4	Reference time	31
Annex A (informative): Other procedures		31
A.1	Antenna verification.....	33
History		35

Intellectual Property Rights

< Editor's note: To be filled in. >

Foreword

This specification has been produced within the Third Generation Partnership Project (3GPP), and has been elaborated by the TSG RAN WG1 working group, as a part of the work in defining and describing Layer 1 of the Universal Mobile Terrestrial Radio Access (UTRA).

This specification describes the physical layer procedures in UTRA/FDD.

1 Scope

This document specifies and establishes the characteristics of the physical layer procedures in the FDD mode of UTRA.

2 References

The following documents contain provisions which, through reference in this text, constitute provisions of the present document.

- References are either specific (identified by date of publication, edition number, version number, etc.) or non-specific.
- For a specific reference, subsequent revisions do not apply.
- For a non-specific reference, subsequent revisions do apply.
- A non-specific reference to an ETS shall also be taken to refer to later versions published as an EN with the same number.

[1] Reference 1

3 Definitions, symbols and abbreviations

3.1 Definitions

For the purposes of the present document, the following definitions apply:

<defined term>: <definition>.

3.2 Symbols

For the purposes of the present document, the following symbols apply:

<symbol> <Explanation>

3.3 Abbreviations

For the purposes of the present document, the following abbreviations apply:

<u>ASC</u>	<u>Access Service Class</u>
BCH	Broadcast Channel
CCPCH	Common Control Physical Channel
DCH	Dedicated Channel
DPCCH	Dedicated Physical Control Channel
DPCH	Dedicated Physical Channel
DPDCH	Dedicated Physical Data Channel
FACH	Forward Access Channel
MUI	Mobile User Identifier
PCH	Paging Channel
PI	Paging Indication
PRACH	Physical Random Access Channel
RACH	Random Access Channel
SCH	Synchronisation Channel
SIR	Signal-to-Interference Ratio
SSDT	Site Selection Diversity TPC
TPC	Transmit Power Control
UE	User Equipment

4 Synchronisation procedures

4.1 Cell search

During the cell search, the UE searches for a cell and determines the downlink scrambling code and frame synchronisation of that cell. The cell search is typically carried out in three steps:

Step 1: Slot synchronisation

During the first step of the cell search procedure the UE uses the SCH's primary synchronisation code to acquire slot synchronisation to a cell. This is typically done with a single matched filter (or any similar device) matched to the primary synchronisation code which is common to all cells. The slot timing of the cell can be obtained by detecting peaks in the matched filter output.

Step 2: Frame synchronisation and code-group identification

During the second step of the cell search procedure, the UE uses the SCH's secondary synchronisation code to find frame synchronisation and identify the code group of the cell found in the first step. This is done by correlating the received signal with all possible secondary synchronisation code sequences, and identifying the maximum correlation value. Since the cyclic shifts of the sequences are unique the code group as well as the frame synchronisation is determined.

Step 3: Scrambling-code identification

During the third and last step of the cell search procedure, the UE determines the exact primary scrambling code used by the found cell. The primary scrambling code is typically identified through symbol-by-symbol correlation over the Primary CCPCH with all codes within the code group identified in the second step. After the primary scrambling code has been identified, the Primary CCPCH can be detected, super-frame synchronisation can be acquired and the system- and cell specific BCH information can be read.

If the UE has received a priority list with information about which scrambling codes to search for, steps 2 and 3 above can be simplified.

4.2 Primary CCPCH synchronisation

Synchronisation of the Primary CCPCHs is obtained during the cell search, see subclause 4.1 above. Frame synchronisation is obtained in step 2 of the cell search, and super-frame synchronisation is obtained by reading the SFN information on the BCH.

4.3 Secondary CCPCH synchronisation

Synchronisation of the Secondary CCPCHs can be obtained from the Primary CCPCH synchronisation and the timing offset information T_d broadcasted on the BCH. T_d is described in chapter 7 of 25.211.

4.4 PRACH synchronisation

< Editor's note: This needs to be co-ordinated with the random access description. Contents of this subclause comes from Volume 3 section 3.2.5.1 and XX.03 subclause 5.2.2.1.1. >

Transmission of random access bursts on the PRACH is done aligned with access slot times. The timing of the access slots is derived from the received Primary CCPCH timing. The transmit timing of access slot n starts $n \times 10/N$ ms after the frame boundary of the received Primary CCPCH, where $n = 0, 1, \dots, N-1$, and N is the number of access slots per 10 ms.

4.5 DPCCH/DPDCH synchronisation

4.5.1 General

The synchronisation of the dedicated physical channels can be divided into two cases:

- when a downlink dedicated physical channel and uplink dedicated physical channel shall be set up at the same time;
- or when a downlink dedicated physical channel shall be set up and there already exist an uplink dedicated physical channel.

The two cases are described in subclauses 5.5.1 and 5.5.2 respectively.

4.5.2 No existing uplink dedicated channel

The assumption for this case is that a DPCCH/DPDCH pair shall be set up in both uplink and downlink, and that there exist no uplink DPCCH/DPDCH already. This corresponds to the case when a dedicated physical channel is initially set up on a frequency.

The outline of synchronization establishment procedures of the dedicated physical channel is described below. The detailed synchronization establishment process flow is shown in Figure 1.

- a) The network starts the transmission of downlink channels. The TPC commands transmitted by the network follows a predetermined pattern, < Editor's note: What pattern? >. The DPDCH is transmitted only when there is data to be transmitted to the UE.
- b) The UE establishes downlink chip synchronization and frame synchronization based on the Primary CCPCH synchronization timing and the frame offset group, slot offset group notified from the network. The frame synchronization could be confirmed using the Frame Synchronization Word. The success of the frame synchronization confirmation is determined when the successive S_R frame synchronization is confirmed. Otherwise, the frame synchronization confirmation failure is determined. Then this synchronization status information is reported to the upper layer.
- c) The UE starts the transmission of uplink channels at the frame timing delayed by the slot offset from the downlink channel. The DPDCH is transmitted only when there is data to be transmitted to the network. The

transmission power of uplink channels follows the TPC commands transmitted by the network. TPC commands transmitted by the UE are based on downlink SIR measurements.

- d) The network establishes uplink channel chip synchronization and frame synchronization based on the frame offset group and slot offset group. Frame synchronization could be confirmed using the Frame Synchronization Word. The success of the frame synchronization confirmation is determined when the successive S_R frame synchronization is confirmed. Otherwise, the frame synchronization confirmation failure is determined. Then this synchronization status information is reported to the upper layer. The transmission power of the downlink channels follow the TPC commands transmitted by the UE.

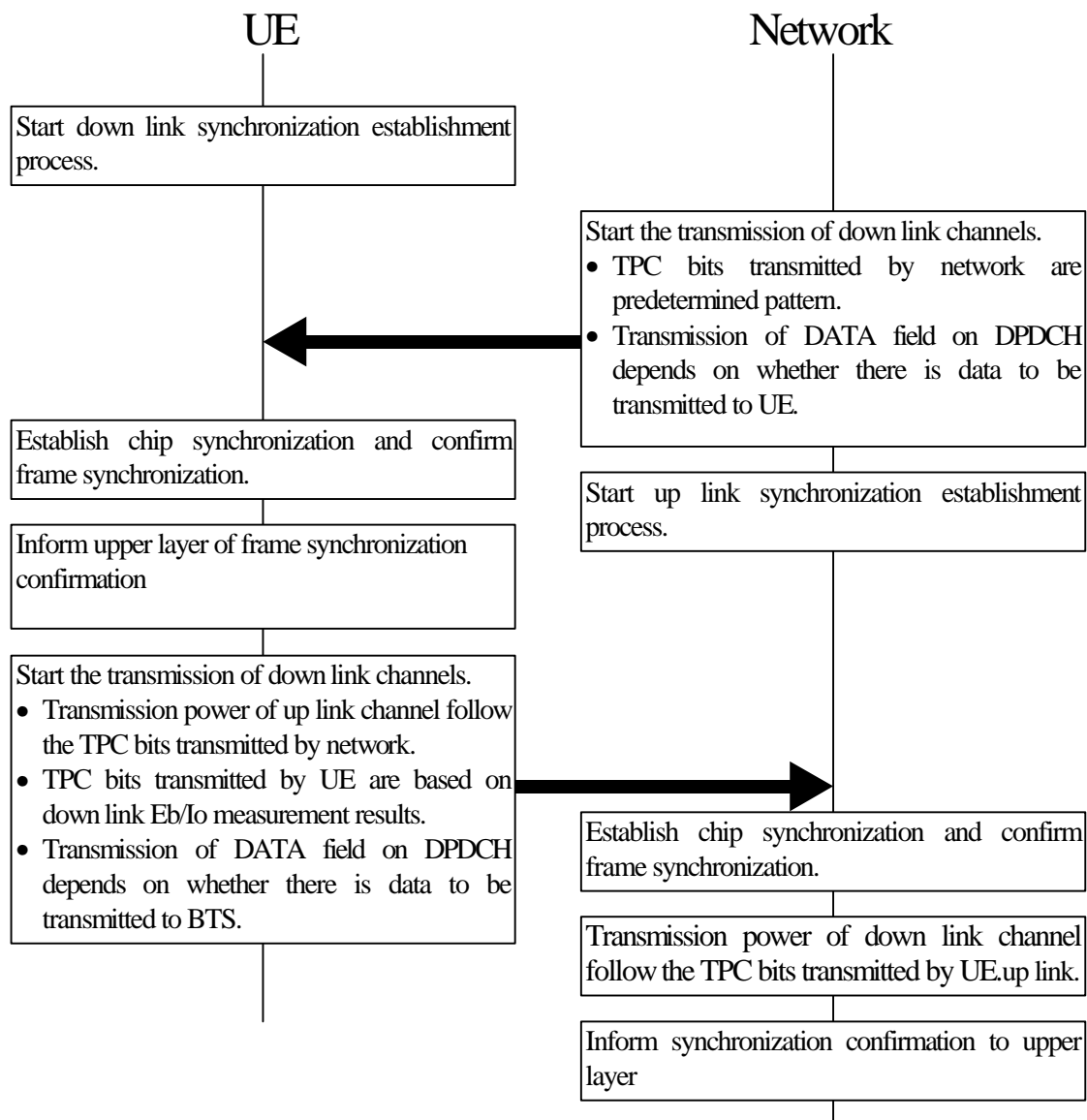

Figure 1: Synchronization Establishment Flow of Dedicated Channels

4.5.3 With existing uplink dedicated channel

The assumption for this case is that there already exist DPCCH/DPDCHs in the uplink, and a corresponding dedicated physical channel shall be set up in the downlink. This corresponds to the case when a new cell has been added to the active set in soft handover and shall begin its downlink transmission.

< Editor's note: The actual procedure below is based on the material in Volume 3 section 3.2.6.6.1. Material not relevant for L1 has been removed. The terminology should be updated in accordance with the rest of the specification.

The figure should also be updated. This will be done in the next version of this document. The criteria for synchronisation confirmation should be considered informative, and should be moved to an informative annex >

At the start of diversity handover, the uplink dedicated physical channel transmitted by the UE, and the downlink dedicated physical channel transmitted by the diversity handover source node B will have their radio frame number and scrambling code phase counted up continuously as usual, and they will not change at all.

The synchronisation establishment flow upon intra/inter-cell diversity handover is described in Figure 2.

- a) The UE starts the chip synchronization establishment process of downlink channels from the handover destination. The uplink channels being transmitted shall continue transmission without any operations performed.
- b) The network starts the transmission of downlink dedicated physical channels and starts the synchronization establishment process of uplink dedicated physical channel transmitted by the UE. Frame synchronization could be confirmed using the Frame Synchronization Word. The success of the frame synchronization confirmation is determined when the successive S_R frame synchronization is confirmed. Otherwise, the frame synchronization confirmation failure is determined. Then this synchronization status information is reported to the upper layer.
- c) Based on the handover destination Primary CCPCH reception timing, the UE establishes chip synchronization of downlink channels from handover destination node B. Frame synchronization could be confirmed using the Frame Synchronization Word. The success of the frame synchronization confirmation is determined when the successive S_R frame synchronization is confirmed. Otherwise, the frame synchronization confirmation failure is determined. Then this synchronization status information is reported to the upper layer.

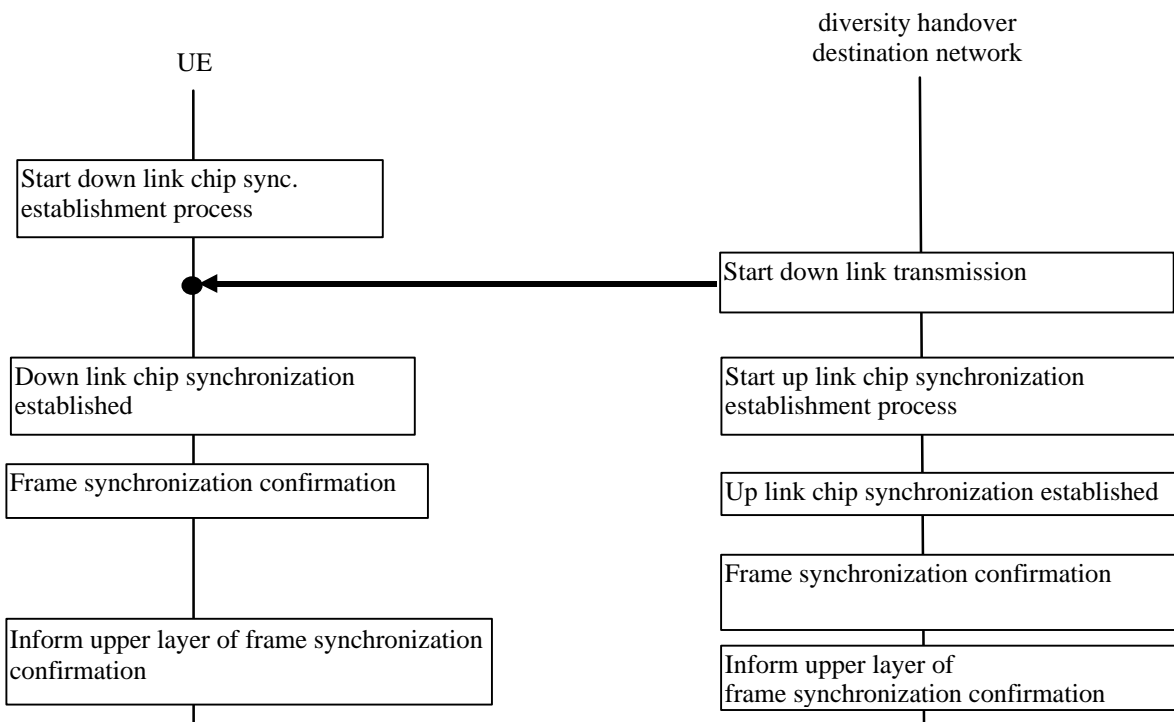

Figure 2: Synchronization Establishment Flow Upon Intra/Inter-cell Diversity Handover

5 Power control

5.1 Uplink power control

5.1.1 PRACH

< Editor's note: This clause describes open loop power control scheme for PRACH. To be confirmed appropriate S documents for open loop power control, and moved this description to the appropriate S document.>

- The transmitter power of UE shall be calculated by following equation:

$$P_{\text{RACH}} = L_{\text{Perch}} + I_{\text{BTS}} + \text{Constant value}$$
 where,
 P_{RACH} : transmitter power level in dBm,
 L_{Perch} : measured path loss in dB,
 I_{BTS} : interference signal power level at BTS in dBm, which is broadcasted on BCH,
 Constant value: This value shall be designated via Layer 3 message (operator matter).

5.1.2 DPCCH/DPDCH

5.1.2.1 General

The uplink transmit power control procedure controls simultaneously the power of a DPCCH and its corresponding DPDCHs. The power control loop adjusts the power of the DPCCH and DPDCHs with the same amount. The relative transmit power offset between DPCCH and DPDCHs is determined by the network and signalled to the UE using higher layer signalling.

5.1.2.2 Ordinary transmit power control

5.1.2.2.1 General

<Notes: A minimum power control step size of 1 dB is mandatory. Smaller step sizes are FFS. Their support would be optional.>

The initial uplink transmit power to use is decided using an open-loop power estimate, similar to the random access procedure. < Editor's note: This needs to be elaborated, how is the estimate derived? >

The maximum transmission power at the maximum rate of DPDCH is designated for uplink and control must be performed within this range. < Editor's note: The necessity of this range needs to be confirmed. > The maximum transmit power value of the closed-loop TPC is set by the network using higher layer signalling.

The uplink closed-loop power control adjusts the UE transmit power in order to keep the received uplink signal-to-interference ratio (SIR) at a given SIR target, SIR_{target} . An higher layer outer loop adjusts SIR_{target} independently for each cell in the active set.

The serving cells (cells in the active set) should estimate signal-to-interference ratio SIR_{est} of the received uplink DPCH. The serving cells then generates TPC commands and transmits the commands once per 0.625-ms slot according to the following rule: if $SIR_{\text{est}} > SIR_{\text{target}}$ then the TPC command to transmit is "0", while if $SIR_{\text{est}} < SIR_{\text{target}}$ then the TPC command to transmit is "1".

If multiple TPC commands are received, then upon reception of these TPC commands, the UE combines the received commands into a single TPC command, TPC_{cmd} . The combination process depends on whether the transmitted TPC commands are known to be the same or not. The combination process for each of these two cases is described in subclauses 5.1.2.2.2 and 5.1.2.2.3 respectively.

The step size Δ_{TPC} is a UE specific parameter that can have the values 1 dB or 2 dB.

Note : the maximum power control step to be support by the UE shall be 3 dB, 3 dB being allowed for the compressed mode. It is FFS whether the 3 dB should also be allowed in normal mode.

Two algorithms shall be supported by the UE and are described in the following sections :

5.1.2.2.1.1 Algorithm 1

After calculation of the combined TPC command TPC_cmd, the UE ~~then shall~~ adjusts the transmit power of the uplink dedicated physical channels with a step of Δ_{TPC} dB according to the TPC command. If TPC_cmd equals 1 then the transmit power of the uplink DPCCH and uplink DPDCHs shall be increased by Δ_{TPC} dB. If TPC_cmd equals 0 then the transmit power of the uplink DPCCH and uplink DPDCHs shall be decreased by Δ_{TPC} dB.

The power increase or decrease shall take place immediately before the start of the pilot field on the DPCCH.

5.1.2.2.1.2 Algorithm 2

After calculation on a slot basis of the combined TPC command (TPC_cmd) for N consecutive slots, the UE will determine a global command. The set of N concatenated commands do not overlap (no running concatenation), and the sets are aligned to the frame boundary. This global command will result in an increase or decrease of the transmit power of the uplink dedicated physical channels with a step of Δ_{TPC} dB or no change of the transmit power.

The exact computation of the global command to calculate every N slots was agreed as a working assumption. Characteristics of this algorithms are as follows :

- N=3 or N=5
- Hard decision on the N commands is performed
- A power increase or decrease is applied if the N commands are identical

Editor's note : The deadline for the number of concatenated commands and other details is WG1#7, in absence of input at WG1#7 the above described algorithm with N=3 will become the agreement. A more detailed text proposal needs to be done, and the behaviour in compressed mode as well as soft handover with TPC combining needs to be elaborated.
≥

NOTE : The algorithm 2 allows to emulate smaller step sizes than the minimum power control step as specified above.

< Editor's note: In Volume 3, it is stated that the time for changing transmit power shall be immediately before the pilot block. This is linked to slot structure (ad hoc 7), and could be described in 25.211.>

The power increase or decrease shall take place immediately before the start of the pilot field on the DPCCH.

The step size Δ_{TPC} is a parameter that may differ between different cells. In the event different step sizes are used in the different serving cells, then the transmit power change should take into account the TPC command obtained by combining individual commands and the different step sizes, and should be one of the allowed step sizes (FFS).

< Editor's note: The information in the paragraphs below is found in Volume 3 only.>

The initial uplink transmit power to use is decided using an open loop power estimate, similar to the random access procedure. < This needs to be elaborated later on. How is the estimate derived? >

5.1.2.2.1.3 Out of synchronisation handling

If the TPC commands cannot be received due to downlink out of synchronisation, the transmit power shall be kept constant. When SIR measurements cannot be performed due to uplink out of synchronisation, the TPC command transmitted shall be set as "1" during the period of out of synchronisation.

The maximum transmission power at the maximum rate of DPDCH is designated for uplink and control must be performed within this range. < Editor's note: To be confirm the necessity of this range > The maximum transmit power value of the closed loop TPC is set by the network using higher layer signalling.

The ordinary transmit power control of uplink dedicated physical channels is summarised in Figure 3 below.'

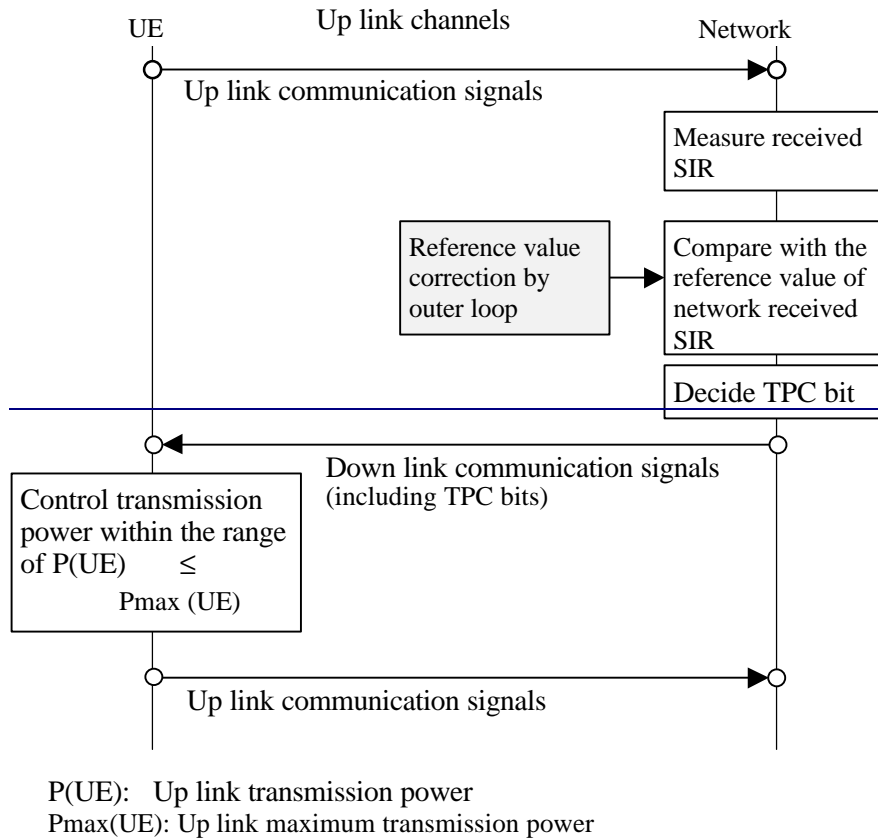

Figure 3: Reverse link transmitter power control by SIR-based Closed Loop

5.1.2.2.2 Combining of TPC commands known to be the same

In some cases, the UE has the knowledge that some of the transmitted TPC commands are the same. This is the case e.g. with receiver diversity or so called softer handover when the UTRAN transmits the same command in all the serving cells the UE is in softer handover with. For these cases, the TPC commands known to be the same are combined into one TPC command, to be further combined with other TPC commands as described in subclause 5.1.2.2.3.

5.1.2.2.3 Combining of TPC commands not known to be the same

In general in case of soft handover, the TPC commands transmitted in the different cells may be different.

This subclause describes the general scheme for combination of the TPC commands known to be different and then provides an example of such scheme. It is to be further decided what should be subject to detailed standardisation, depending on final requirements. The example might be considered as the scheme from which minimum requirement will be derived or may become the mandatory algorithm.

5.1.2.2.3.1 General scheme

First, the UE shall estimate the signal-to-interference ratio PC_SIR_i on each of the power control command TPC_i , where $i = 1, 2, \dots, N$ and N is the number of TPC commands known to be different, that may be the results of a first phase of combination according to subclause 5.1.2.2.3.

Then the UE assigns to each of the TPC_i command a reliability figure W_i , where W_i is a function β of PC_SIR_i , $W_i = \beta(PC_SIR_i)$. Finally, the UE derives a combined TPC command, TPC_cmd , as a function γ of all the N power control commands TPC_i and reliability estimates W_i :

$TPC_cmd = \gamma(W_1, W_2, \dots, W_N, TPC_1, TPC_2, \dots, TPC_N)$, where TPC_cmd can take the values 0 or 1.

5.1.2.2.3.2 Example of the scheme

A particular example of the scheme is obtained when using the following definition of the functions β and γ :

For β : the reliability figure W_i is set to 0 if $PC_SIR_i < PC_thr$, otherwise W_i is set to 1. This means that the power control command is assumed unreliable if the signal-to-interference ratio of the TPC commands is lower than a minimum value PC_thr .

For γ : if there is at least one TPC_i command, for which $W_i = 1$ and $TPC_i = 0$, then TPC_cmd is set to 0, otherwise TPC_cmd is set to 1. Such a function γ means that the power is decreased if at least one cell for which the reliability criterion is satisfied asks for a power decrease.

5.1.2.3 Transmit power control in compressed mode

< Note: The following is a working assumption of WG1. >

The aim of uplink power control in downlink or/and uplink compressed mode is to recover as fast as possible a signal-to-interference ratio (SIR) close to the target SIR after each transmission gap.

In downlink compressed mode, no power control is applied during transmission gaps, since no downlink TPC command is sent. Thus, the transmit powers of the uplink DPDCH(s) and DPCCH are not changed during the transmission gaps.

In simultaneous downlink and uplink compressed mode, the transmission of uplink DPDCH(s) and DPCCH is stopped during transmission gaps. <Note: the initial transmit power of each uplink DPDCH or DPCCH after the transmission gap is FFS. >

After each transmission gap, 2 modes are possible for the power control algorithm. The power control mode (PCM) is fixed and signalled with the other parameters of the downlink compressed mode (see TS 25.231). The different modes are summarised in the table 1:

Table 1. Power control modes during compressed mode.

<u>Mode</u>	<u>Description</u>
<u>0</u>	<u>Ordinary power control is applied with step size Δ_{TPC}</u>
<u>1</u>	<u>Ordinary power control is applied with step size Δ_{RP-TPC} during one or more slots after each transmission gap.</u>

<Note: The exact power control algorithm in compressed mode when concatenation of TPC commands are used in normal mode is still FFS. The current description only applies when no concatenation is done in normal mode. >

For mode 0, the step size is not changed and the ordinary power control is still applied during compressed mode (see subclause 5.1.2.2).

For mode 1, during one or more slots after each transmission gap, called the recovery period, the ordinary power control algorithm is applied but with a step size Δ_{RP-TPC} instead of Δ_{TPC} , where Δ_{RP-TPC} is called recovery power control step size and is expressed in dB. The step size Δ_{RP-TPC} is equal to the minimum value of 3 dB and $2\Delta_{TPC}$.

After the recovery period the ordinary power control algorithm with step Δ_{TPC} is performed.

The recovery period length (RL) determination is still FFS and is to be chosen between the two following possibilities:

- The recovery period length is fixed and derived as a function of the Transmission mode parameters mostly the transmission gap period and possibly the spreading factor.

- The recovery period length is adapted and ends when the current and previous received power control commands are opposite or after TGL slots after the transmission gap.

5.2 Downlink power control

5.2.1 Primary CCPCH

The Primary CCPCH transmit power can vary on a slow basis, i.e. the power is constant over many frames. The transmit power is determined by the network and signalled on the BCH.

5.2.2 Secondary CCPCH

The Secondary CCPCH transmit power is set by the network, and may vary.

5.2.3 DPCCH/DPDCH

5.2.3.1 General

The downlink transmit power control procedure controls simultaneously the power of a DPCCH and its corresponding DPDCHs. The power control loop adjusts the power of the DPCCH and DPDCHs with the same amount, i.e. the relative power difference between the DPCCH and DPDCHs is not changed.

The relative transmit power offset between DPCCH fields and DPDCHs is determined by the network and signalled to the UE using higher layer signalling. The TFCI, TPC and pilot fields of the DPCCH are offset relative to the DPDCHs power by PO1, PO2 and PO3 dB respectively. *< Editor's note: The range and need for signaling with power offsets is FFS.>*

5.2.3.2 Ordinary transmit power control

< Note: Working assumption is that minimum step size of 1 dB is mandatory, and minimum step size of 0.5 dB is optional.>

The downlink closed-loop power control adjusts the network transmit power in order to keep the received downlink SIR at a given SIR target, SIR_{target} . A higher layer outer loop adjusts SIR_{target} independently for each connection.

The UE should estimate the received downlink DPCCH/DPDCH power of the connection to be power controlled. Simultaneously, the UE should estimate the received interference. The obtained SIR estimate SIR_{est} is then used by the UE to generate TPC commands according to the following rule: if $SIR_{est} > SIR_{target}$ then the TPC command to transmit is "0", requesting a transmit power decrease, while if $SIR_{est} < SIR_{target}$ then the TPC command to transmit is "1", requesting a transmit power increase.

< Editor's note: How the SIR estimate should be derived is to be specified, in particular how it should be done for the case with power offsets on the DPCCH.>

The TPC command generated is transmitted in the first available TPC field in the uplink DPCCH.

< Editor's note: In Volume 3, the behaviour of the network is only given as examples. This leaves full freedom for the network to decide how to respond to the TPC commands received. However, in XX.07 more information about the networks behaviour is given: "Upon the reception of a TPC command, the network should adjust the transmit power in the given direction with a step of D_{TPC} dB. The step size D_{TPC} is a parameter that may differ between different cells, in the range 0,25—1,5 dB." It is the view of the editor that the implementation of the network behaviour is not subject to standardisation. To be confirmed.>

< Note: It is not clear to what extent the UTRAN response to the received TPC commands should be specified. Until this has been clarified, the text in the paragraph below should be seen as an example of UTRAN behaviour. >

As a response to the received TPC commands, UTRAN may adjust the downlink DPCCH/DPDCH power. Such a change of power shall be a multiple of the minimum step size $\Delta_{\text{TPC,min}}$ dB. It is mandatory for UTRAN to support $\Delta_{\text{TPC,min}}$ of 1 dB, while support of 0.5 dB is optional.

< Note: It needs to be clarified if an upper limit on the downlink power step should be specified. >

'When SIR measurements cannot be performed due to downlink out-of-synchronisation, the TPC command transmitted shall be set as "1" during the period of out-of-synchronisation.

< Editor's note: In Volume 3 it is also described how the power should be controlled during link set-up. This should probably be described in the synchronisation clause, so that the information is not repeated in several places. >

~~The ordinary transmit power control of uplink dedicated physical channels is summarised in Figure 4 below.'~~

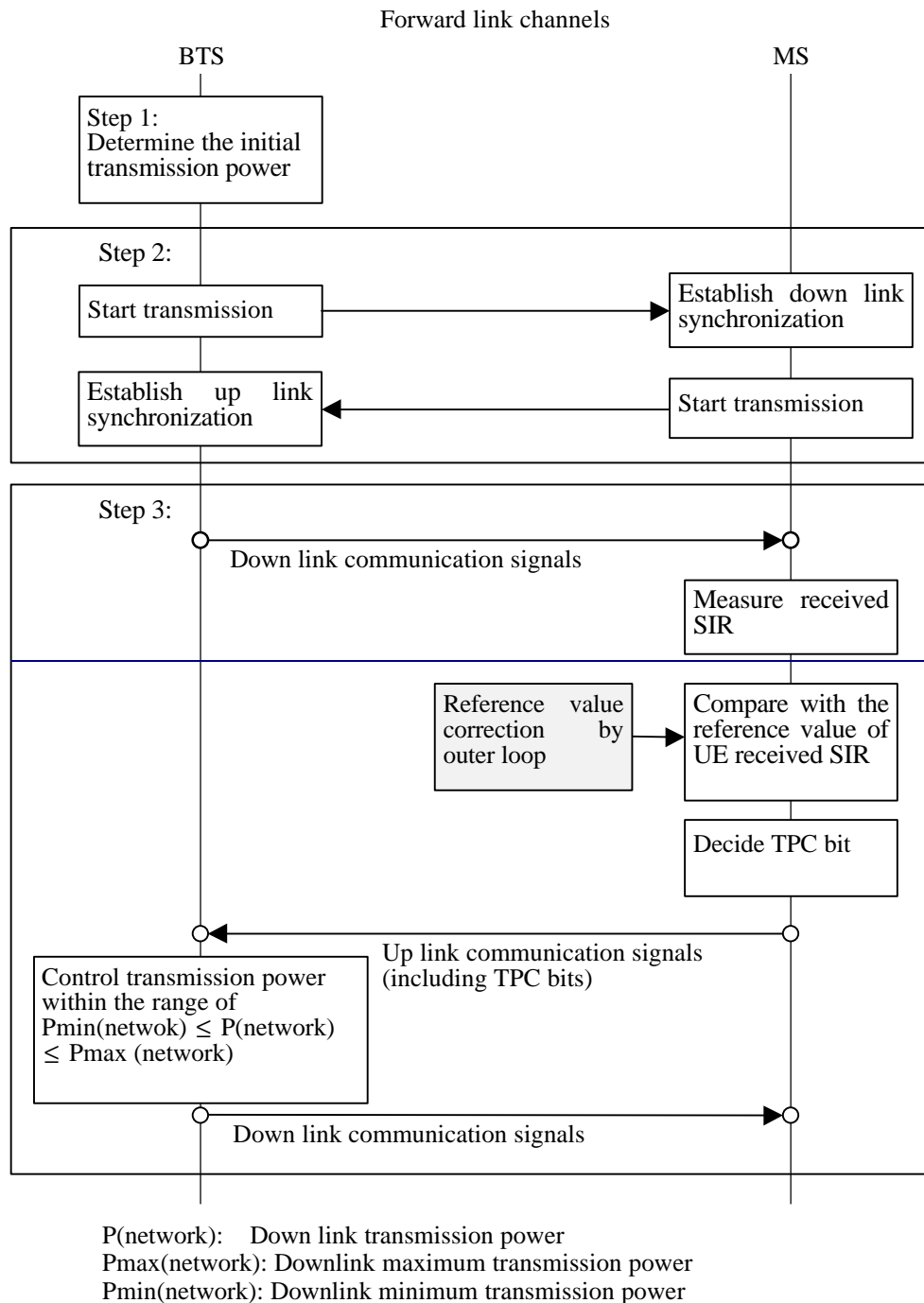

Figure 4: Forward link transmitter power control

5.2.3.3 Power control in compressed mode

The aim of downlink power control in uplink or/and downlink compressed mode is to recover as fast as possible a signal-to-interference ratio (SIR) close to the target SIR after each transmission gap.

The UE behaviour is the same in compressed mode as in normal mode, described in subclause 5.2.3.2, i.e. TPC commands should be generated based on the estimated received SIR.

The UTRAN behaviour during compressed mode is not specified. As an example, the algorithm can be similar to uplink power control in downlink compressed mode as described in sub-clause 5.1.2.3.

In downlink compressed mode or in simultaneous downlink and uplink compressed mode, the transmission of downlink DPCCH and DPDCH(s) is stopped.

5.2.3.43 Slow transmit power control

Following an order from the network and acknowledgement by the UE, ordinary fast closed-loop transmit power control can be stopped and a slow transmit power control mode can be entered. In this mode, downlink DPCCH/DPDCH transmit power is determined utilising power control ratios reported from the UE. Uplink transmission is suspended when the UE does not have any information to send, and the transmission is resumed to send a power control ratio at least once in every T_{RINT} second. The UE calculates power control ratios in the following steps:

1. The UE measures the PCCPCH-CPICH power of the cell in which the UE is located, and sets the value to Q_1 .
2. The UE measures PCCPCH-CPICH powers received from neighbouring cells, and sets the values greater than Q_1/R_{SEARCH} to Q_i , where $i = 2, 3, \dots, n$.
3. The UE sets the power control ratio to $(Q_1 + Q_2 + \dots + Q_n)/Q_1$.

All TPC bits in the uplink DPCCH are used to send power control ratios. One power control ratio is sent per frame, i.e. ~~3032~~ TPC bits are used to carry the power control ratio. The coding method is the same as that of default TFCI word described in 4.3.1.1. The bi-orthogonal (32,6) code described in subclause 6.3.1 is used for the encoding. There are 64 code words. Code word $C_{32,m}$ corresponds to $0.5(m-1)$ dB and code word $C_{32,m}^*$ corresponds to $\{0.5(m-1)+0.25\}$ dB where $m = 0, 1, 2, \dots, 31$ and $n = 0, 1, 32$.

Following an order from the network, the slow transmit power control is stopped and ordinary fast closed-loop transmit power control is started. The parameters T_{RINT} and R_{SEARCH} are set using higher layer signalling.

5.2.3.54 Site selection diversity transmit power control

< Editor's note: In general, the text describing SSDT should be checked to identify L1 and L23 issues separately. Some contents should perhaps be moved to WG2 documentation. The text could also be made more specification-like. For the time being the text is kept with some cosmetic and language related changes. >

5.2.3.54.1 General

Site selection diversity transmit power control (SSDT) is an optional macro diversity method in soft handover mode.

Operation is summarised as follows. The UE selects one of the cells from its active set to be 'primary', all other cells are The main objective is to transmit on the downlink from the best cell, thus reducing the interference caused by multiple transmissions in a soft handover mode. A second objective is to achieve fast site selection without network intervention, thus maintaining the advantage of the soft handover. In order to select a primary cell, each cell is assigned a temporary identification and UE periodically informs a primary cell identification to the connecting cells. The non-primary cells selected by UE switch off the transmission power. The primary cell identity code is delivered via uplink FBI field.

5.2.3.54.2 Initiation of SSDT

The SSDT is initiated by the network, based on the soft handover active cell set. The cell and UE are subsequently informed by the network that the SSDT option has been activated during the current soft handover period. Otherwise, TPC is operated in the ordinary mode, i.e. each cell controls its power in accordance with an uplink TPC command by the way described in 5.2.3.2. The temporary cell identification assignment (i.e. ID code assignment) is based on the order of active set which is communicated to all the active cells and the UE.

A cell receiving the active list is capable of recognising its entry position in the list from which it can determine its own ID code. Similarly, UE upon receiving the active list can determine the ID code of each of the active cells according to the order of the cell entries in the list. Therefore the network and UE has the same association between the ID codes and cells. After the activation of the SSDT and the subsequent UE acknowledgements, the UE starts to send the "primary" cell ID code, described in the following subclauses. Following a successful activation of SSDT and reception of the UE acknowledgement, the active cells start detecting the "primary" cell ID information.

5.2.3.54.3 Settings of temporary cell identification

Each cell is given a temporary identification during SSDT and the identification is utilised as site selection signal. In the following, the temporary identification is referred to as "ID".

5.2.3.54.3.1 Definition of temporary cell identification

The ID is given a binary bit sequence. There are three different lengths of coded ID available denoted as "long", "medium" and "short". The network decides which length of coded ID is used and notifies it to both UE and cells by higher layer signaling message in the initiation of SSST. Settings of ID codes for 1-bit and 2-bit FBI are exhibited in Table 2 and Table 3, respectively.

Table 2 Settings of ID codes for 1 bit FBI

ID label	ID code		
	"long"	"medium"	"short"
a	0000000000000000	0000000(0)	00000
b	1111111111111111	1111111(1)	11111
c	0000000011111111	0000111(1)	00011
d	1111111000000000	1111000(0)	11100
e	0000111111110000	0011110(0)	00110
f	1111000000001111	1100001(1)	11001

Table 3 Settings of ID codes for 2 bit FBI

ID label	ID code (Column and Row denote slot position and FBI-bit position.)		
	"long"	"medium"	"short"
a	0000000(0)	000(0)	000
	0000000(0)	000(0)	000
b	1111111(1)	111(1)	111
	1111111(1)	111(1)	111
c	0000000(0)	000(0)	000
	1111111(1)	111(1)	111
d	1111111(1)	111(1)	111
	0000000(0)	000(0)	000
e	0000111(1)	001(1)	001
	1111000(0)	110(0)	100
f	1111000(0)	110(0)	110
	0000111(1)	001(1)	011

ID must be terminated within a frame. If FBI space for sending a given ID cannot be obtained within a frame, hence if the entire ID is not transmitted within a frame but must be split over two frames, the last bit(s) of the ID is(are) punctured. The relating bit(s) to be punctured are shown with brackets in Table 2 and Table 3.

The ID is given a binary bit sequence with the length of N_{BID} bits. The parameter N_{BID} can take the value 4, 8, or 16 bits. Setting examples of ID codes are exhibited in Table 1.

Table 1: Setting examples of ID codes

ID label	ID code		
	$N_{\text{BID}}=16$	$N_{\text{BID}}=8$	$N_{\text{BID}}=4$
a	0000000000000000	00000000	0000
b	1111111111111111	11111111	1111
e	0000000011111111	00001111	0011
d	1111111100000000	11110000	1100
e	0000111111110000	00111100	0110
f	1111000000001111	11000011	1001

5.2.3.54.3.2 Assignment of ID to each cell

The "ID" word assignment is based on the entry position in the active list, which is compiled and communicated to all active cells and UE.

Table 4: ID assignment example

Number of cells in active set	ID label assignment for each cell					
	Entry position in active set					
	1	2	3	4	5	6
1	a					
2	a	b				
3	a	b	c			
4	a	b	c	d		
5	a	b	c	d	e	
6	a	b	c	d	e	f

5.2.3.54.3.3 Notification of ID assignment change

Every time that the active list is changed, it is updated and communicated to all active cells and UE.

5.2.3.54.4 TPC procedure in UE

The TPC procedure of the UE in SSDT is identical to that described in subclause 5.2.3.2.

5.2.3.54.5 Selection of primary cell

The UE selects a primary cell periodically by measuring reception levels of common pilots transmitted by the active cells. The cell with the highest pilot power is detected as a primary cell.

5.2.3.54.6 Delivery of primary cell ID

The UE periodically sends the ID code of the primary cell via [portion of the uplink FBI field assigned for SSDT use \(FBI S field\)](#). A cell recognises its state as non-primary if the following two conditions are fulfilled simultaneously:

- the received primary ID code does not match with the own ID code,
- and the received uplink signal quality satisfies a quality threshold, Q_{th} , a parameter defined by the network.

Otherwise the cell recognises its state as primary.

At the UE, the primary ID code to be sent to the cells is segmented into a number of portions. These portions are distributed in the uplink FBI S-field. The cell in SSDT collects the distributed portions of the primary ID code and then detects the transmitted ID. Period of primary cell update depends on the settings of [code length](#) N_{FBIS} and the number of FBI bits [assigned for SSDT use](#) as shown in Table 5

Table 5 Period of primary cell update

code length	The number of FBI bits per slot assigned for SSDT	
	<u>1</u>	<u>2</u>
"long"	1 update per frame	2 updates per frame
"medium"	2 updates per frame	4 updates per frame
"short"	3 updates per frame	5 updates per frame

	The number of FBI bits per slot
--	---

	1	2
$N_{\text{BFD}}=16$	Every 16 slots	Every 8 slots
$N_{\text{BFD}}=8$	Every 8 slots	Every 4 slots
$N_{\text{BFD}}=4$	Every 4 slots	Every 2 slots

5.2.3.54.7 TPC procedure in the network

In SSDT, a non-primary cell can switch off its output power (i.e. no transmissions).

5.2.3.54.7.1 Management of multiple transmission power levels

The cell manages two downlink transmission power levels, P1, and P2, for each UE in soft handover. Power level P1 keeps track of the minimum downlink power required, if the cell is chosen as the primary cell. The cell updates P1 regardless of the selected state (primary or non-primary). The data fields from non-primary cells are transmitted at power level P2. When a cell is selected by the UE as the primary cell, P2 is set to P1, otherwise the cell maintains P2 at the minimum transmit level (i.e. data fields power off). P1 and P2, expressed in dBm, are updated in accordance with TPC commands from the UE as shown in Table 6. The two power settings P1 and P2 are maintained within the power control dynamic range.

Table 6: Updating of P1 and P2

State of cell	TPC signal	P1	P2
non primary	down	$P1 - \Delta_{\text{TPC}}$	Switched off
	up	$P1 + \Delta_{\text{TPC}}$	Switched off
primary	down	$P1 - \Delta_{\text{TPC}}$	= P1
	up	$P1 + \Delta_{\text{TPC}}$	= P1

Δ_{TPC} is defined in subclause 5.2.3.2. < Editor's note: Maybe it is not defined in standard, see comment in 5.2.3.2. > No regulation of initial value of P1 and P2 is given.

5.2.3.54.7.2 Power setting of the downlink Dedicated Physical Channel

The downlink Dedicated Physical Channel is partitioned into 5 portions as shown in Figure 9 of S25.211. Power setting of each portion during SSDT is depicted in Figure 3.

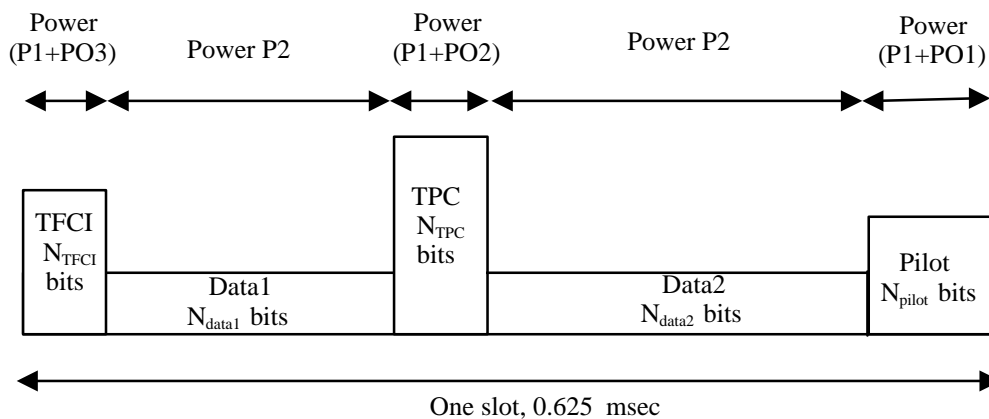

Figure 3: Power setting of the downlink Dedicated Physical Channel

Transmission power of the TPC and TFI portions are always set to P1, in order to detect the control information at the UE with high reliability.

5.2.3.54.8 Termination of SSDT

The decision to terminate the SSDT is made by the network, based on the UE reported received signal strength levels of all the active and candidate list pilots. The termination request should be informed by the network to both cells and UE in the same way as soft handoff termination process.

5.2.4 Power Control with DSCH

The DSCH power control can be based on the following solutions, which are selectable, by the network.

- Fast closed loop power control based on the power control commands sent by the UE on the uplink DPCCCH.
- Slow power control.

6 Random access procedure

Before the random-access procedure is executed, the UE should acquire the following information from the BCH :

- The preamble spreading code(s) / message scrambling code(s) used in the cell
- The available signatures [for each ASC](#)
- The available ~~access slots~~ [sub-RACH channels, defined by parameter A. A contains four bits. The A parameter values \$0000 \leq A \leq 0111\$ are used with AICH transmission timing parameter value 0, and values \$0000 \leq A \leq 1111\$ with AICH transmission timing parameter value 1. If a certain bit position in parameter A has value 1, it means that corresponding sub-RACH channel is available. Sub-RACH channel # can have a value among {0,1,2,3}. The LSB of parameter A corresponds to sub-RACH channel # = 0, and the MSB of parameter A corresponds to sub-RACH channel # = 3. The available access slots for different sub-RACH channels are shown in tables 5 and 6 for transmission timing parameter values 0 and 1, respectively.](#)
- The available spreading factors for the message part
- The uplink interference level in the cell
- The primary CCPCH transmit power level
- The AICH transmission timing parameter as defined in [S4-25.211](#).
- The power offsets ΔP_0 (power step when no acquisition indicator is received, step 7.3) and ΔP_1 (power step when negative acquisition is received, see step 8.3)

The random-access procedure is:

1. The UE randomly selects a preamble spreading code from the set of available spreading codes. The random function is TBD.
2. The UE sets the preamble transmit power to the value P_{RACH} given in Section 5.1.1. [*Editor's note: Here it is assumed that the initial power back-off is included in the "Constant Value" of 5.1.1*]
3. The UE implements the dynamic persistence algorithm by:
 - 3.1 Reading the current dynamic persistence value from the BCH.
 - 3.2 Perform a random draw against the current dynamic persistence value. The random function is TBD.
 - 3.3 Defer transmission for one frame and repeat step 3 if the result of the random draw is negative, otherwise proceed to step 4.

[Editor's note: The dynamic persistence value may not be transmitted every frame, depending on the BCH scheduling, i.e step 3.1 cannot be executed every iteration.]

- 4 The UE:

~~Randomly selects an uplink access slot from the available uplink access slots. Random function is TBD.~~

- 4.1 ~~Randomly selects the sub RACH channel from the available ones, with the help of A parameter and AICH transmission timing parameter. The A parameter values $0000 \leq A \leq 0111$ are used with AICH transmission timing parameter value 0, and values $0000 \leq A \leq 1111$ with AICH transmission timing parameter value 1. If a certain bit position in parameter A has value 1, it means that corresponding sub-RACH channel is available, among the possible {0,1,2,3}. The random function, for selecting the sub RACH channel from the available ones is TBD.~~
- 4.2 ~~Derives the available access slots of frame SFN in the selected sub-RACH channel with the help of SFN and AICH transmission timing parameter value.~~
 - ~~If AICH transmission timing parameter value is 0, the access slots of frame SFN are defined by $\text{Access} = 3 * N + (\text{SFN modulo } 2) + \text{sub RACH channel \#}$, where N has values of the range $0 \leq N \leq 4$, and sub RACH channel # is the selected sub RACH channel, with the condition that only the values between $0 \leq \text{Access} \leq 7$ are valid in frames with even SFN and only the values between $8 \leq \text{Access} \leq 14$ are valid in frames with odd SFN. UE selects the available access slot to which there is smallest distance.~~
 - ~~If AICH transmission timing parameter value is 1, the access slots of frame SFN are defined by $\text{Access} = 4 * N + (\text{SFN modulo } 8) + \text{sub RACH channel \#}$, where N has values of the range $0 \leq N \leq 3$, and sub RACH channel # is the selected sub RACH channel, with the condition that only the values between $0 \leq \text{Access} \leq 7$ are valid in frames with even SFN and only the values between $8 \leq \text{Access} \leq 14$ are valid in frames with odd SFN. UE selects the available access slot to which there is smallest distance.~~
- 4.3 Randomly selects a signature from the available signatures within the ASC given by higher layers. Random function is TBD.
- 5 ~~5-~~The UE sets the Preamble Retransmission Counter to Preamble_Retrans_Max (value TBD).
- 6 The UE transmits its preamble using the selected uplink access slot, signature, and preamble transmission power..
- 7 If the UE does not detect the positive or negative acquisition indicator corresponding to the selected signature in the downlink access slot corresponding to the selected uplink access slot, the UE:
 - 7.1 ~~Selects a new uplink access slot, by using the timing requirements for τ_{p-p} defined in TS 25.211, where it is defined that $\tau_{p-p} = 3$ access slots if AICH transmission timing value is set to 0, and $\tau_{p-p} = 4$ access slots if AICH transmission timing value is set to 1., This new access slot must be one of the available access slots. There must be also a distance of three or four access slots from the uplink access slot in which the last preamble was transmitted depending on the AICH transmission timing parameter. The selection scheme of this new access slot is TBD.~~
 - 7.2 Randomly selects a new signature from the available signatures within the ASC given by higher layers. Random function is TBD.
 - 7.3 Increases the preamble transmission power with the specified offset ΔP_0 .
 - 7.4 Decrease the Preamble Retransmission Counter by one.
 - 7.5 If the Preamble Retransmission Counter > 0 , the UE repeats from step 6 otherwise an error indication is passed to the higher layers and the random-access procedure is exited.
8. If the UE detects the negative acquisition indicator corresponding to the selected signature in the downlink access slot corresponding to the selected uplink access slot, the UE:
 - 8.1 Selects a new uplink access slot as in 7.1
 - 8.2 Randomly selects a new signature from the available signatures within the ASC given by higher layers. Random function is TBD.
 - 8.3 Modifies the preamble transmission power with the specified offset ΔP_1 .

[Editor's note: Note clear if the Preamble Retransmission Counter should be decremented and tested in this case]

8.4 Repeats from step 6

9. The UE transmits its random access message three or four uplink access slots after the uplink access slot of the last transmitted preamble depending on the AICH transmission timing parameter...

10. A indication of successful random-access transmission is passed to the higher layers.

Dynamic persistence is provided for managing interference and minimising delay by controlling access to the RACH channel. The system will publish a dynamic persistence value on the BCH, the value of which is dependent on the estimated backlog of users in the system.

Table 7 The available access slots, Access, for different sub-RACH channels, when AICH transmission timing parameter = 0.

<u>Frame number</u>	<u>Sub-RACH channel #=0</u> (A=001) <u>Access</u>	<u>Sub-RACH channel #=1</u> (A=010) <u>Access</u>	<u>Sub-RACH channel #=2</u> (A=100) <u>Access</u>
<u>SFN modulo 2 = 0</u>	<u>0, 3, 6</u>	<u>1, 4, 7</u>	<u>2, 5</u>
<u>SFN modulo 2 = 1</u>	<u>9, 12</u>	<u>10, 13</u>	<u>8, 11, 14</u>

Table 8 The available access slots, Access, for different sub-RACH channels, when AICH transmission timing parameter = 1.

<u>Frame number</u>	<u>Sub-RACH channel #=0</u> (A=0001) <u>Access</u>	<u>Sub-RACH channel #=1</u> (A=0010) <u>Access</u>	<u>Sub-RACH channel #=2</u> (A=0100) <u>Access</u>	<u>Sub-RACH channel #=3</u> (A=1000) <u>Access</u>
<u>SFN modulo 8 = 0</u>	<u>0, 4</u>	<u>1, 5</u>	<u>2, 6</u>	<u>3, 7</u>
<u>SFN modulo 8 = 1</u>	<u>8, 12</u>	<u>9, 13</u>	<u>10, 14</u>	<u>11</u>
<u>SFN modulo 8 = 2</u>	<u>1, 5</u>	<u>2, 6</u>	<u>3, 7</u>	<u>0, 4</u>
<u>SFN modulo 8 = 3</u>	<u>9, 13</u>	<u>10, 14</u>	<u>11</u>	<u>8, 12</u>
<u>SFN modulo 8 = 4</u>	<u>2, 6</u>	<u>3, 7</u>	<u>0, 4</u>	<u>1, 5</u>
<u>SFN modulo 8 = 5</u>	<u>10, 14</u>	<u>11</u>	<u>8, 12</u>	<u>9, 13</u>
<u>SFN modulo 8 = 6</u>	<u>3, 7</u>	<u>0, 4</u>	<u>1, 5</u>	<u>2, 6</u>
<u>SFN modulo 8 = 7</u>	<u>11</u>	<u>8, 12</u>	<u>9, 13</u>	<u>10, 14</u>

7 Transmission stop and resumption control

< Editor's note: This control schem is under discussion in ad hoc 14.>

7.1 General

'On dedicated physical channels, when no higher layer data exist to transmit, the DPDCH is empty and is not transmitted. In order to save channel capacity, under some conditions the transmission of the DPCCH can also be stopped. Similarly, conditions are also defined for how the transmission of DPCCH/DPDCH is resumed.

< Editor's note: From Volume 3 figure 3.2.6-16 it seems that the transmission stop scheme is only applicable when the other link do not transmit a DPDCH, while this is not explained in the text. Clarification is needed on this point. >

7.2 Transmission stop control

7.2.1 Network control procedure

'The necessity of downlink DPCCH/DPDCH transmission is judged in each radio frame. When the DPDCH is stopped, i.e. there is no data to transmit on the DPDCH, the network continues to transmit the DPCCH until both

Figure 1999 Fkp-f radio frames have passed after the DPDCH transmission was stopped,

- and Frc-b radio frames are detected consecutively with no correct CRC in uplink,

when the DPCCH transmission is stopped as well.

The parameters Fkp-f [= 2] and Frc-b [= 2] are set by higher layer procedures.

7.2.2 UE control procedure

'The necessity of uplink DPCCH/DPDCH transmission is judged in each radio frame. When the DPDCH is stopped, i.e. there is no data to transmit on the DPDCH, the UE continues to transmit the DPCCH until both

Figure 1999 Fkp-b radio frames have passed after the DPDCH transmission was stopped,

- and the downlink is detected to be out-of-synchronisation,

when the DPCCH transmission is stopped as well.

The parameter Fkp-b [= 2] is set by higher layer procedures.

7.2.3 Illustration of network and UE procedures

'Figure 4 illustrates the scheme for the case where there exist a DPCCH/DPDCH in downlink and a DPCCH in uplink, and transmission of the downlink DPDCH is stopped.

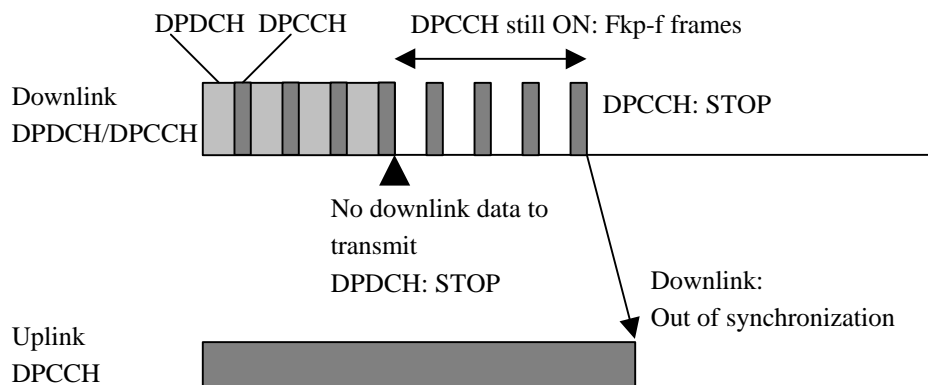

Figure 4: Transmission stop control when downlink DPDCH is stopped

Figure 5 illustrates the scheme for the case where there exist a DPCCH/DPDCH in uplink and a DPCCH in downlink, and transmission of the uplink DPDCH is stopped.

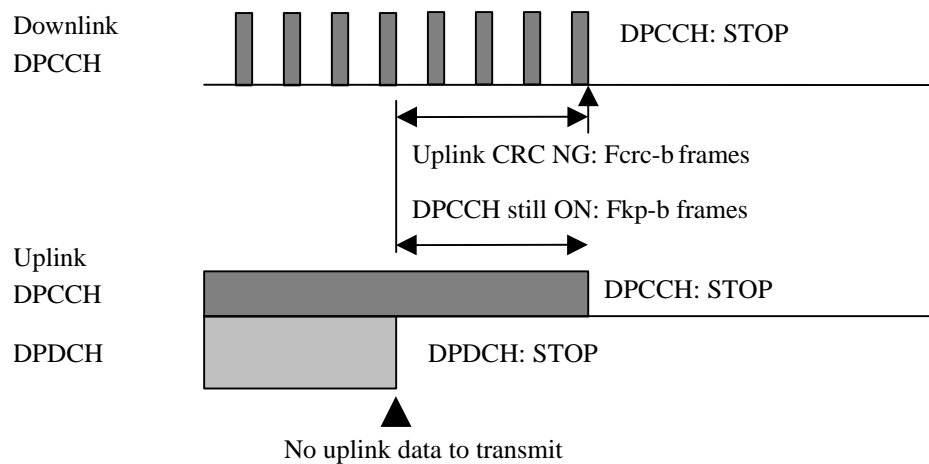

Figure 5: Transmission stop control when uplink DPDCH is stopped

7.3 Transmission resumption control

7.3.1 Network control procedure

'Suspended downlink DPCCH/DPDCH transmission is resumed without higher layer signals if data to be transmitted on the DPDCH is generated. When resuming DPDCH transmission, the network transmits dummy frames prior to radio frames with real data.

The number of dummy frames to transmit is F_{tr} . If the number of frames after pausing transmission of both DPCCH and DPDCH is less than F_{gap} , where chip and frame synchronisation is expected to be kept, the dummy frames consist of only DPCCH (pilot and TPC) transmitted in the last Str slots of each dummy frame. If the number of frames after pausing transmission is more than F_{gap} , the dummy frames consist of only DPCCH, and the TPC commands are set to a predetermined pattern, for example indicating transmission power increase.'

The network selects an initial transmission power to be used when starting to send the dummy frames, and increases its transmission power by P_{up} dB in each Sup slots until receiving the DPCCH in the uplink, but the maximum transmission power is limited to P_{max} dBm. After sending the dummy frames, closed-loop power control is applied to the downlink transmission as described in subclause 5.2.3.

Also, suspended downlink DPCCH transmission is resumed when synchronisation is established with the corresponding uplink dedicated physical channel that was previously in out-of-synchronisation. When DPCCH transmission is resumed the network selects an initial transmission power to be used, and applies closed-loop power control to the downlink transmission as described in subclause 5.2.3.

The parameters F_{tr} [=2], Sup [=4], P_{up} [= 1], P_{max} , F_{gap} [= 2], Str [= 4] are set by higher layer procedures. The values of these parameters may be set differently between network and UE.

< Editor's note: The parameter P_{add} was removed, since it is anyway up to the network to set the initial power as it wishes. >

7.3.2 UE control procedure

'Suspended uplink DPCCH/DPDCH transmission is resumed if data to be transmitted on the DPDCH is generated. When resuming DPDCH transmission, the UE transmits dummy frames prior to radio frames with real data.

The number of dummy frames to transmit is F_{tr} . The dummy frames consist of only DPCCH (pilot and TPC) transmitted in the last Str slots of each dummy frame. The TPC commands are set to a predetermined pattern, for example indicating transmission power increase.

Using an open-loop transmit power estimate similar to the one described in subclause 5.1.1, the UE derives an initial transmission power to be used when starting to send the dummy frames, and increases its transmission power by P_{up} dB in each Sup slots until receiving the DPCCH in the downlink, but the maximum transmission power is limited to

P_{max} dBm. After sending the dummy frames, closed-loop power control is applied to the uplink transmission as described in subclause 5.1.2.

Also, suspended uplink DPCCH transmission is resumed when synchronisation is established with the corresponding downlink dedicated physical channel that was previously in out-of-synchronisation. When DPCCH transmission is resumed the UE selects an initial transmission power to be used based on an open-loop transmit power estimate similar to the one described in subclause 5.1.1, and applies closed-loop power control to the uplink transmission as described in subclause 5.1.2.

The parameters F_{tr} [=2], Sup [=4], P_{up} [= 1], P_{max}, F_{gap} [= 2], Str [= 4] are set by higher layer procedures. The values of these parameters may be set differently between network and UE.

7.3.3 Illustration of network and UE procedures

Figure 6 illustrates the scheme for the case where transmission of downlink DPDCH is resumed.

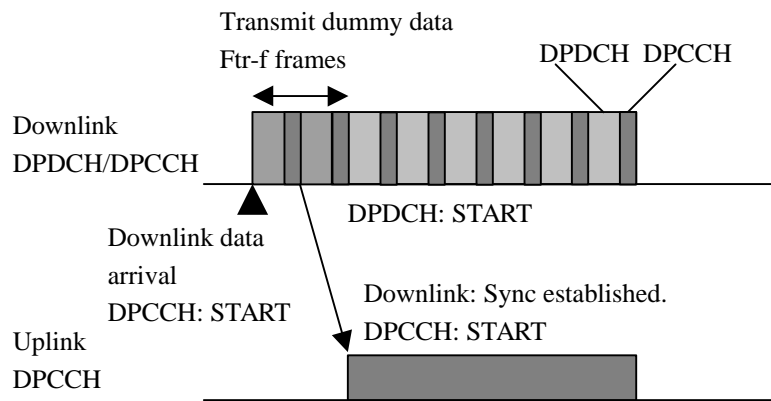

Figure 6: Transmission resumption of downlink DPDCH

Figure 7 illustrates the scheme for the case where transmission of uplink DPDCH is resumed.

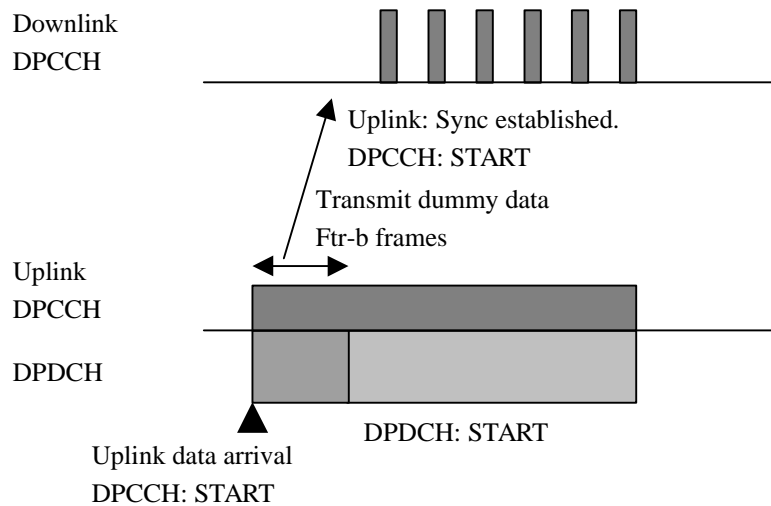

Figure 7: Transmission resumption of uplink DPDCH

8 Feedback mode transmit diversity

8.1 DPCH transmission scheme

The transmitter structure to support Feedback (FB) mode transmit diversity for DPCH transmission is shown in Figure 1. Channel coding, interleaving and spreading are done as in non-diversity mode. The spread complex valued signal is fed to both TX antenna branches, and weighted with antenna specific weight factors w_1 and w_2 . The weight factors are complex valued signals (i.e., $w_i = a_i + jb_i$), in general.

The weight factors are determined by the UE, and signaled to the UTRAN access point (=cell transceiver) through the uplink DPCCCH.

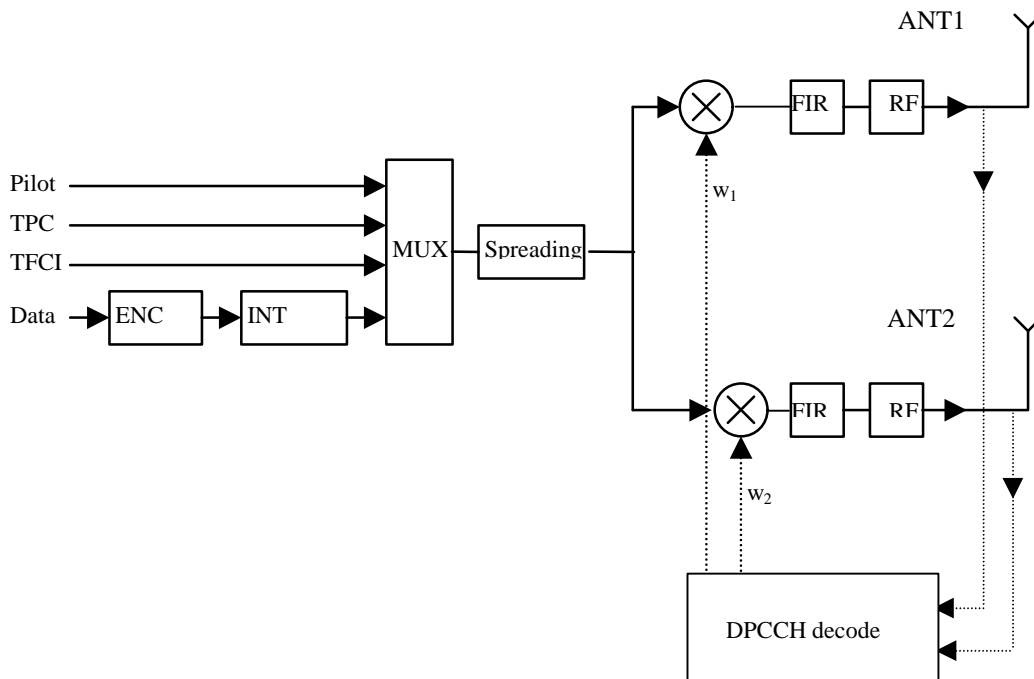

Figure 8. Downlink transmitter structure to support FB Mode Transmit Diversity for DPCH transmission (UTRAN Access Point)

8.2 Uplink signaling channel

The UE feeds back to the UTRAN access point the information on which phase/power settings to use (the “weights”). Feedback Signaling Message (FSM) bits are transmitted in the portion of FBI field of uplink DPCCCH slot(s) assigned to FB Mode Transmit Diversity, the FBI D field (see 25.21). Each message is of length $N_w = N_{po} + N_{ph}$ bits and its format is shown in the Figure 9. The transmission order of bits is from UEB to LSB, i.e. UEB is transmitted first. FSM_{po} and FSM_{ph} subfields are used to transmit the power and phase settings, respectively.

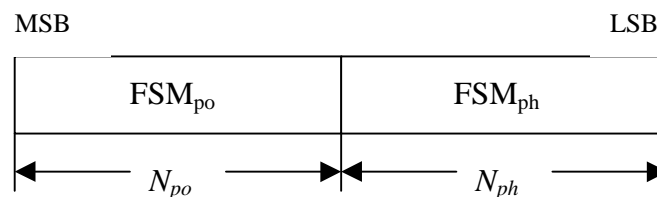

Figure 9. Format of feedback signaling message. FSM_{po} transmits the power setting and FSM_{ph} the phase setting.

Table 9 lists the N_{FBDF} (number of bits in the FBI D-field of a slot), N_w , update rate, feedback bit rate and number of power and phase bits per signaling word for different feedback modes.

Table 9 N_{FBDI} , N_W , update rate, feedback bit rate and number of power and phase bits per signalling word for different feedback modes

FB mode	N_{FBDI}	N_W	Update rate	Feedback bit rate	N_{po}	N_{ph}
1	1	1	1500 1600 Hz	1500 1600 bps	0 1	1 0
2	1	2	750 800 Hz	1500 1600 bps	0	2
	<u>2</u>		<u>1500</u> Hz	<u>3000</u> bps		
3	1	4	375 400 Hz	1500 1600 bps	1	3
	<u>2</u>		<u>750</u>	<u>3000</u> bps		

Table 10 to Table 13 below give the binary signalling words, together with their interpretation at the transmit array (in terms of relative powers and phases to be applied between the antennas).

Table 10 Feedback mode 1 signalling message. No FSM_{po} , FSM_{ph} is transmitted.

FSM_{ph}	Phase difference between antennas (degrees)
<u>0</u>	<u>180</u>
<u>1</u>	<u>0</u>

FSM_{po}	Power_ant1	Power_ant2
\emptyset	\emptyset	\pm
\pm	\pm	\emptyset

Table 11 Feedback mode 2 signalling message. No FSM_{po} is transmitted.

FSM_{ph}	Phase difference between antennas (degrees)
00	180
01	-90
11	0
10	90

Table 12 FSM_{po} subfield of feedback mode 3 signalling message.

FSM_{po}	Power_ant1	Power_ant2
0	0.2	0.8
1	0.8	0.2

Table 13 FSM_{ph} subfield of feedback mode 3 signalling message.

FSM_{ph}	Phase difference between antennas (degrees)
000	180
001	-135
011	-90
010	-45
110	0
111	45
101	90
100	135

When $N_{po}=0$, equal power is applied to each antenna.

Antennas 1 and 2 are uniquely defined by their respective Primary CCPCH pilot codes.

The FSM must be wholly contained within a frame. To achieve this, in certain cases adjustments are required as follows:

- For Mode 2 with $N_{\text{FBD}}=1$, only the MSB of the last FSM per frame is transmitted by the UE. The Node B applies the average phase difference between the 2 possible phase differences allowed given this first bit (i.e. 45 or -135 degrees).
- For Mode 3 with $N_{\text{FBD}}=1$, for the last FSM in the frame the UE sends only the FSM_{ph} portion. The Node B applies the same power ratio as for the previous FSM.
- For Mode 3 with $N_{\text{FBD}}=2$, for the last FSM in the frame the UE sends only the 2 MSBs of the FSM_{ph} portion. The Node B applies the same power ratio as for the previous FSM and maps the 2 first bits to a phase difference according to table 3.

The amplitude and phase applied per antenna is called a “weight”, and the set of weights is grouped into a “weight vector”. Specifically, the weight vector in the case of 2 antennas is given by

$$\underline{w} = \begin{bmatrix} \sqrt{\text{power_ant1}} \\ \sqrt{\text{power_ant2}} \cdot \exp(j \text{p.phase_diff} / 180) \end{bmatrix} \quad (1)$$

8.3 Determination of feedback information

The UE uses the pilots transmitted on the Primary CCPCH to separately estimate the channels seen from each antenna.

Once every $N_{\text{slot}}=N_{\text{w}}/N_{\text{FBI}}$ slot times, the UE computes the phase and power adjustments that should be applied at the UTRAN access point to maximize the UE received power, from within the set of adjustments allowed by the chosen feedback mode defined with Tables 1 to 5.

In a generic sense for the non-soft handover case, this is the weight vector \underline{w} that maximizes

$$P = \underline{w}^H \mathbf{H}^H \mathbf{H} \underline{w} \quad (2)$$

where

$$\mathbf{H} = [\underline{h}_1 \ \underline{h}_2 \ \dots]$$

and where the column vector \underline{h}_i represents the estimated channel impulse response for the i 'th transmission antenna, of length equal to the length of the channel impulse response.

During soft handover or SSDT power control, the antenna weight vector, w is determined so as to maximize the criteria function.

$$P = \underline{w}^H (\underline{H}_1^H \underline{H}_1 + \underline{H}_2^H \underline{H}_2 + \dots) \underline{w}$$

where \underline{H}_i is an estimated channel impulse response for BS# i . In regular SHO, the set of BS# i corresponds to the active set. With SSDT, the set of BS# i corresponds to the primary base station(s).

8.4 Antenna verification

In FB mode 1, if channel estimates are taken from the Primary CCPCH, the performance will also suffer if the UE can not detect errors since the channel estimates will be taken for the incorrect antenna. To mitigate this problem, antenna verification can be done, which can make use of antenna specific pilot patterns of the dedicated physical channel. The antenna verification can be implemented with several different algorithms. As an example if we have different pilot patterns on the downlink DPCH we can apply coherent antenna verification in which we select

antenna with pilot pattern s_1 if the following relation holds,

$$2 \operatorname{Re}\{\mathbf{w}_1^H \mathbf{y} - \mathbf{w}_2^H \mathbf{y}\} - \|\mathbf{w}_1\|^2 + \|\mathbf{w}_2\|^2 > \hat{S}^2 \ln \frac{P(s_2)}{P(s_1)} \quad (2)$$

where $P(s_1)$ and $P(s_2) = 1 - P(s_1)$ are the *a priori* probabilities for pilot patterns (=transmit antenna) s_1 and s_2 , respectively, \hat{S}^2 is an estimate of noise power, $\mathbf{w}_i = [\hat{a}_{i,1}s_i[0], \dots, \hat{a}_{i,L}s_i[N-1]]^T$, $y_l[i]$ is correlator output for path l , and $\hat{a}_{1,l}$ and $\hat{a}_{2,l}$ denote the channel estimates for antennas. In normal operation the *a priori* probability for selected pilot pattern is assumed to be 96% (assuming there are 4% of errors in the feedback channel for power control and antenna selection).

9 Reverse link synchronous transmission

< Editor's note: This clause is only to be found in ARIB Volume 3. Some more discussion on this technique is probably needed, and for now the original text is kept. The physical layer procedures of RSTS needs to be identified and further refined and described in this clause. >

9.1 General

Reverse Link Synchronous Transmission (RSTS) can reduce reverse link intra-cell interference by means of making a node B receive orthogonalized signals from UEs in the cell. To orthogonalize receiving signals from UEs,

- the same scrambling code is allocated to all dedicated physical channels in the cell,
- different orthogonal spreading codes are allocated to all dedicated physical channels across all UEs in the cell, and
- the signal arrival time of each UE is adjusted.

The modulation scheme according to RSTS is described in <update 3.2.4.2.1.2.2>. The timing control procedures are described later in this section. RSTS is an alternative technology applicable for low mobility terminals. A system mainly accommodating low mobility terminals may adopt the RSTS.

The transmission time control is carried out by two steps. The first step is initial synchronization and the second is tracking.

- 1) Initial synchronization: Adjust transmission time through the initial timing control message over FACH
- 2) Tracking Process (Closed Loop Timing control): Adjust the transmission time through the Time Alignment Bit (TAB) over DTCH.

9.2 Initial synchronisation

- When the node B received signal from UE over RACH, node B measures the difference in time between the received timing and the reference time.
- The message for initial synchronization is delivered to UE via FACH.

- UE adjust its transmission time according to the message (the maximum amount of adjustments corresponds to the round trip delay of a cell).
- When the difference in time of initial measurement in the first step is not big, it is possible to skip these initial synchronization processes.

9.3 Tracking process

- Node B periodically compares the difference between the reference time and received signal timing from UE.
- When the received timing is earlier than the reference time, Time Alignment Bit (TAB) = "0". When this is later

Since the timing control is carried out at much lower rate than TPC, TAB replaces the TPC bit every timing control period 20 msec. (In the exemplary embodiment, the timing control period equals to the frame length or multiples of it. In case of the example of timing control every frame, the first TPC bit of each frame is replaced by TAB)

- At the UE, soft decision on the TAB shall be performed, and when it is judged as "0", the transmission time shall be delayed by 1/4 (or 1/8) chip, whereas if it is judged as "1", the transmission time shall be advanced by 1/4 (or 1/8) chip.

9.4 Reference time

The reference time is set up at the starting point of forward-link frame plus the median value between minimum and maximum round trip delay within a cell. < Editor's note: How can one take the median of two values? >

Annex A (informative): Other procedures

A.1 Paging procedure

< Editor's note: If it is decided to keep this clause, the network operation should be moved to SI.11, and the annex could be renamed paging detection and possibly also moved to SI.11. >

A.1.1 Network operation

~~Every UE belongs to one group. When a Paging message to a UE in a specific group is transmitted in a specific S-CCPCH frame, the corresponding Page Indicator in the corresponding frame on the associated Page Indicator Channel is set to "1". In all other cases, the Page Indicators are set to "0". The paging message includes the mobile station identification number of the UE for which the paging message was intended.~~

A.2 Forward link power control

< Editor's note: The contents of this clause have been taken from Volume 3 ANNEX, It is needed to consider the necessity of this description in S documents since the contents are related to node B operation not to UE operation. And it is needed to consider where the contents should be described. >

A.2.1 Forward link power control under hand-over mode

< Editor's note: The contents of this clause have been taken from Volume 3 ANNEX A >

~~In the forward link, fast closed loop power control with TPC bits should be applied in order to reduce interference and increase capacity. However, not every node B under hand over mode can satisfy the required quality. In the node B with poor quality, TPC bits error could be occurred, so that it cannot control the forward link power properly. There is possibility of that the radio link is released forcefully if the transmitting power from some node Bs is~~

lower than the appropriate value. On the other hand, the capacity decrease if the power is higher than the value.

— Forward link slow power control with layer 3 messages should be applied to support fast closed loop power control. Layer 3 messages for the control are terminated at the inter-cell combining node, so that their quality meet the required level under hand-over mode. The node B which cannot receive TPC bits correctly decides its forward link power by the slow power control. Fig. A.1 shows an example of slow power control under hand-over mode.

A.2.2 Forward link power control of dedicated physical channel

<Editor's note: The contents of this clause have been taken from Volume 3 ANNEX B>

— During SIR-based fast closed loop control, node Bs employ adjustment loop, in which node Bs change transmission power in every N_{int} slots by the following equation:

$$P_{closed\ loop} = Pref + r (P_{closed\ loop} - Pref)$$

— $P_{closed\ loop}$: SIR-based fast closed loop control in dBm

where

— r : constant value ($0 < r < 1$),

— $Pref$: referen Fig. A.1 Forward link slow power control

A.2.3 Forward link power control of dedicated physical channel in hand-over mode

<Editor's note: The contents of this clause have been taken from Volume 3 ANNEX C>

— In hand-over mode, node Bs employ enhanced transmission power control in addition to fast closed loop control. Transmission power of dedicate physical channel P_{dpch} [dBm] is derived from the following equation:

$$P_{dpch} = P_{closed\ loop} + P_{enhanced}$$

where

— $P_{closed\ loop}$: SIR-based fast closed loop control in dBm

— $P_{enhanced}$: enhanced transmission power control in dB

— $P_{enhanced}$ is derived in the following steps:

(a) node Bs set 0 [dB] to $P_{enhanced}$.

(b) node Bs measure average SIR of N_{ave} slots.

(c) If the average SIR is larger than $T_{sir} + T_{exc}$ (T_{sir} : target SIR in dB, T_{exc} : allowable SIR range in dB), node Bs add P_{sup} [dB] to $P_{enhanced}$. If $P_{enhanced}$ is greater than $P_{enhancedmax}$ ($P_{enhancedmax}$: maximum value of $P_{enhanced}$ in dB), node Bs set $P_{enhancedmax}$ to $P_{enhanced}$.

(d) If the average SIR is equal to or small than $T_{sir} + T_{exc}$, node Bs subtract P_{sdn} [dB] from $P_{enhanced}$. If $P_{enhanced}$ is less than 0 [dB], node Bs set 0 [dB] to $P_{enhanced}$.

A.1 Antenna verification

In FB mode 1, if channel estimates are taken from the Primary CCPCH, the performance will also suffer if the UE can not detect errors since the channel estimates will be taken for the incorrect phase settings. To mitigate this problem, antenna verification can be done, which can make use of antenna specific pilot patterns of the dedicated physical channel. The antenna verification can be implemented with several different algorithms. As an example if we have orthogonal pilot patterns on the downlink DPCCH we can apply coherent antenna verification in which we select

$(\mathbf{a}_1 = 1, \mathbf{a}_2 = 1)$ if

$$2 \sum_{i=1}^{N_{path}} \frac{1}{S_i^2} \left\{ 2 \operatorname{Re}(\mathbf{g} h_{2,i}^{(d)} h_{2,i}^{(p)*}) \right\} > \frac{\ln(\bar{p}(\mathbf{a}_1 = 1, \mathbf{a}_2 = -1))}{\ln(\bar{p}(\mathbf{a}_1 = 1, \mathbf{a}_2 = 1))}$$

where

$h_{2,i}^{(p)}$ is the i 'th estimated channel tap of antenna 2 using the PCCPCH.

$h_{2,i}^{(d)}$ is the i 'th estimated channel tap of antenna 2 using the DPCCH.

γ^2 is the DPCH Pilot SNIR/ PCCPCH Pilot SNIR.

\mathbf{a}_i are the elements of \mathbf{w} .

S_i^2 is the noise plus interference on the i 'th path.

In normal operation the *a priori* probability for selected pilot pattern is assumed to be 96% (assuming there are 4% of errors in the feedback channel for power control and antenna selection).

~~Annex X:~~

~~Description to be study in WG2~~

~~X.1 Outer loop power control~~

~~<Editor's note: The contents of this clause have been taken from Volume 3 section 3.2.6.7.1.2.2 and XX.07 subclause 4.1.2. Details of outer loop should leave out, since it is a higher layer matter.>~~

~~In order to satisfy the required reception quality (average FER, or average BER), the UE should have an outer loop function that updates the reference SIR of fast closed loop transmitter power control depending on quality information. At the UE, outer loop control is performed based on the quality after maximum ratio combining upon DHO. In soft hand over, the quality threshold for the cells in the active set should be adjusted by the outer loop power control (to be implemented in the network nod ewhere soft handover combining is performed).~~

~~In outer loop, UE shall update the reference SIR when UE receives a frame that includes an error detection code (CRC). If CRC result is not OK, the reference SIR shall be raised by SIR_{INC} dB. If CRC result is OK, the reference SIR shall be reduced by SIR_{DEC} dB. SIR_{INC} is 0.5 dB (tentative), and SIR_{DEC} is derived from the following equation :~~

~~$$SIR_{DEC} = SIR_{INC} - FER_{TARGET} / (1 - FER_{TARGET});$$~~

where FER_{TARGET} is the target frame error rate. Initial reference SIR (SIR_{INIT}) is dependent on services, and the maximum/minimum value of reference SIR is limited to SIR_{MAX}/SIR_{MIN} dB. SIR_{INIT} , SIR_{MAX} and SIR_{MIN} are designated via Layer 3 message. The updates of the reference SIR may be conducted together for N_{ILD} frames when channel interleaving depth is N_{ILD} frames.

X.2 Access Control for Multi-rate and/or Multi-code Packet Data Transmission

<Editor's Note: The contents of this clause have been taken from section 3.2.6.10.3 in Volume 3.>

When communicating on RACH/FACH or DCH, the base station assigns more radio resources to lower rate users if the radio resources become free. The base station also controls the data rate according to the transmission power and the channel conditions such as SIR of the forward link. (SIR information is obtained by averaging TPC information from the mobile station. SIR information can be also used for adaptive control such as transmission diversity.)

Figure 12 shows the data rate control diagram. The base station monitors the forward-link traffic condition, and determines the initial data rate for reservation requests by Layer 3 protocol. During communicating, the base station estimates forward-link channel condition for each packet user by averaging the transmission power, and controls the data rate and transmission power in order to avoid excess interference in other mobile stations. If the transmission power for target SIR becomes higher than a threshold value, the base station lowers the transmission rate and power in order to reduce the interference to other mobile stations. On the other hand, if the transmission power for higher rate becomes lower than a threshold value, the base station increases the transmission rate and power in order to reduce channel occupancy. The threshold value is determined according to system environment, e.g., traffic condition. TFCL is updated frame by frame.

The mobile station controls the transmission rate according to the channel conditions in the reverse link as well.

Figure 10: Data rate control diagram

History

Document history		
V0.0.1	1999-02-12	Document created based on ETSI XX.07 V1.3.1 and ARIB Volume 3 ver. 1.0.
V0.1.0	1999-02-26	Version approved by WG1#2. The changes agreed at the meeting to incorporate e.g. ad hoc conclusions not yet included.
V1.0.0	1999-03-04	Version approved by TSG RAN. The changes agreed at the WG1#2 meeting to incorporate e.g. ad hoc conclusions not yet included.
V1.0.1	1999-03-17	Include adhoc conclusions in WG1#2
V1.0.2	1999-03-24	Include adhoc conclusions in WG1#3
V1.1.0	1999-03-25	Version approved by WG1#3.
V2.0.0	1999-04-20	Version approved by WG1#4
V1.0.0	1999-04-23	Version approved by TSG RAN#3
V1.1.0	1999-06-04	Version approved by WG1#5
<p>Editors for 3GPP TSG RAN S1.14 are:</p> <p>Takehiro Nakamura NTT DoCoMo R&D Headquarters Tel: +81 468 40 31 90 Mobile: +81 30 20 05 542 Fax: +81 468 40 38 40 E-mail: takehiro@wsp.yrp.nttdocomo.co.jp</p> <p>This document is written in Microsoft Word 97.</p>		