

**TSG-RAN Working Group 3 meeting**

***TSGR3#6(99)B90***

**September 20<sup>th</sup> - 24<sup>th</sup> 1999**

**Sophia Antipolis, France**

**Title:               Revision of TS 25.401 V1.3.1**

**Source:             Italtel / Siemens**

**Agenda Item:     6.1**

**Document for:    Approval**

---

**3<sup>rd</sup> Generation Partnership Project (3GPP);  
Technical Specification Group (TSG) RAN;  
UTRAN Overall Description**

---

**[UMTS <spec>]**

Reference

---

<Workitem> (<Shortfilename>.PDF)

Keywords

---

<keyword[, keyword]>

**3GPP**

Postal address

---

Office address

---

Internet

---

secretariat@3gpp.org  
Individual copies of this deliverable  
can be downloaded from  
<http://www.3gpp.org>

---

**Copyright Notification**

---

No part may be reproduced except as authorized by written permission.  
The copyright and the foregoing restriction extend to reproduction in all media.

©  
All rights reserved.

# Contents

Intellectual Property Rights .....	7
Foreword .....	7
1 Scope .....	7
2 References .....	7
3 Definitions, symbols and abbreviations .....	8
3.1 Definitions.....	8
3.2 Abbreviations .....	9
3.3 Notation .....	10
4 General principles.....	10
5 UMTS General architecture .....	10
5.1 Overview.....	10
5.2 General protocols architecture .....	11
5.2.1 User plane.....	11
5.2.2 Control plane.....	12
6 UTRAN Architecture .....	12
6.1 UTRAN Identifiers .....	14
6.1.1 PLMN Identifier.....	14
6.1.2 CN Domain Identifier.....	14
6.1.3 RNC Identifier.....	14
6.1.4 Cell Identifier .....	14
6.1.5 UE Identifiers .....	14
6.1.5.1 Usage of RNTI.....	15
6.1.6 Identifiers for dedicated resources within UTRAN.....	15
6.1.6.1 Radio Network Control Plane identifiers.....	15
6.1.6.2 Transport Network Control Plane identifiers.....	16
6.1.6.3 Binding identifier.....	16
6.2 Transport Addresses.....	17
7 UTRAN Functions description.....	18
7.1 List of functions .....	18
7.2 Functions description .....	19
7.2.1 Functions related to overall system access control .....	19
7.2.1.1 Admission Control .....	19
7.2.1.2 Congestion Control.....	19
7.2.1.3 System information broadcasting.....	19
7.2.2 Functions related to security and privacy .....	20
7.2.2.1 Use of Temporary Identifier .....	20
7.2.2.2 Radio channel ciphering .....	20
7.2.2.3 Radio channel deciphering.....	20
7.2.3 Functions related to handover .....	20
7.2.3.1 Radio environment survey .....	20
7.2.3.2 Handover decision .....	21
7.2.3.3 Macro-diversity control .....	21
7.2.3.4 Handover Control .....	21
7.2.3.5 Handover execution .....	22
7.2.3.6 Handover completion.....	22
7.2.3.7 SRNS Relocation .....	22
7.2.3.7.1 Access Network Triggered SRNS Relocation.....	22
7.2.3.7.2 Core Network Triggered SRNS Relocation .....	22
7.2.3.8 Inter-System handover .....	23
7.2.3.8.1 Handover from UMTS to GSM .....	23
7.2.3.8.2 Handover from GSM to UMTS .....	23
7.2.4 Functions related to radio resource management and control.....	23

7.2.4.1	Radio bearer connection set-up and release (Radio Bearer Control) .....	23
7.2.4.2	Reservation and release of physical radio channels .....	24
7.2.4.3	Allocation and deallocation of physical radio channels .....	24
7.2.4.4	Allocation of Downlink Channelisation Codes .....	24
7.2.4.5	Packet data transfer over radio function .....	24
7.2.4.6	RF power control .....	25
7.2.4.6.1	UL OUTER LOOP POWER CONTROL .....	25
7.2.4.6.2	DL OUTER LOOP POWER CONTROL .....	25
7.2.4.6.3	UL INNER LOOP POWER CONTROL .....	25
7.2.4.6.4	DL INNER LOOP POWER CONTROL .....	26
7.2.4.6.5	UL OPEN LOOP POWER CONTROL .....	26
7.2.4.6.6	DL OPEN LOOP POWER CONTROL .....	26
7.2.4.7	Radio channel coding .....	26
7.2.4.8	Radio channel decoding .....	26
7.2.4.9	Channel coding control .....	26
7.2.4.10	Initial (random) access detection and handling .....	26
7.2.4.11	CN Distribution function for Non Access Stratum messages .....	27
8	Mobility Management .....	27
8.1	Dedicated Connection .....	27
8.2	Consequences for Mobility Handling .....	28
9	Synchronisation .....	28
9.1	SYNCHRONISATION MODEL .....	28
9.2	Network Synchronisation .....	29
9.3	Node Synchronisation .....	29
9.4	Time-of-day .....	30
9.5	Counter names and definitions: .....	30
9.6	Layer 2 Synchronisation .....	30
9.6.1	CFN .....	31
9.6.2	Frame_offset .....	32
9.6.3	Cell_SFN .....	32
9.7	Radio Interface synchronisation .....	32
9.7.1	[FDD — Chip Offset] .....	32
9.7.2	[TDD — Time-slot] .....	32
9.7.3	Synchronisation parameters from/to the UE .....	32
9.7.3.1	OFF .....	32
9.7.3.2	Tm .....	33
9.7.3.3	DOFF .....	33
9.8	Calculations performed in the UTRAN .....	34
9.8.1	UE in common channel state .....	34
9.8.2	UE changes state from common CH state to dedicated CH state: 1 RL .....	34
9.8.3	UE changes state from common CH state to dedicated CH state: several RL's .....	34
9.8.4	UE requests to add a new RL in dedicated CH state .....	34
9.8.5	Handover from other RAN to UMTS .....	34
9.9	Calculations performed in the UE .....	34
9.9.1	First RL .....	34
9.9.2	Additional RL's .....	34
9.10	Timing adjustment in Iub/Iur interfaces .....	35
9.11	Synchronisation of L1 configuration changes .....	36
9.12	[TDD — Frame Synchronisation] .....	36
9.12.1	Frame Synchronisation .....	36
9.12.2	Multi Frame Synchronisation .....	37
9.13	Time Alignment handling .....	39
10	UTRAN O&M Requirements .....	39
10.1	O&M of Node B .....	39
10.1.1	Implementation Specific O&M .....	40
10.1.2	Logical O&M .....	40
11	UTRAN Interfaces .....	41
11.1	General Protocol Model for UTRAN Interfaces .....	41

11.1.1	General .....	41
11.1.2	Horizontal Layers .....	41
11.1.3	Vertical Planes.....	41
11.1.3.1	Control Plane .....	41
11.1.3.2	User Plane.....	42
11.1.3.3	Transport Network Control Plane.....	42
11.1.3.4	Transport Network User Plane .....	42
11.2	Protocol Model (Informative).....	42
11.2.1	RACH Transport Channel .....	42
11.2.2	FACH Transport Channel.....	43
11.2.3	DCH Transport Channel.....	44
11.2.4	DSCH Transport Channel.....	45
12	UTRAN Performance Requirements.....	48
12.1	UTRAN delay requirements.....	48
Annex A	TDD Synchronisation port .....	49
Annex B	Document Stability Assessment Table.....	49
History	.....	50

---

# Intellectual Property Rights

## Foreword

This Technical Specification has been produced by the 3<sup>rd</sup> Generation Partnership Project, Technical Specification Group <TSG name>.

The contents of this TS may be subject to continuing work within the 3GPP and may change following formal TSG approval. Should the TSG modify the contents of this TS, it will be re-released with an identifying change of release date and an increase in version number as follows:

Version m.t.e

where:

- m indicates [major version number]
- x the second digit is incremented for all changes of substance, i.e. technical enhancements, corrections, updates, etc.
- y the third digit is incremented when editorial only changes have been incorporated into the specification.

---

## 4 Scope

This document describes the overall architecture of the UTRAN, including internal interfaces and assumptions on the radio and Iu interfaces.

---

## 2 References

*This text block applies to ALL deliverables. The sub-division below applies optionally to TSs.*

The following documents contain provisions which, through reference in this text, constitute provisions of the present document.

- References are either specific (identified by date of publication, edition number, version number, etc.) or non-specific.
- For a specific reference, subsequent revisions do not apply.
- For a non-specific reference, the latest version applies.
- A non-specific reference to an ETS shall also be taken to refer to later versions published as an EN with the same number.

[1] Merged UTRAN Architecture Description V0.0.2

[2] UMTS 23.10 : UMTS Access Stratum Services and Functions

[3] UMTS 25.211: Physical channels and mapping of transport channels onto physical channels (FDD)

*Editor's Note : [1] is a temporary reference only to ease the definition of what should be in the different sections of this document.*

## 3 Definitions, symbols and abbreviations

### 3.1 Definitions

*Editor's Note : Cleaned version of section 5.1 from [1] with a reference to a more general vocabulary document*

<b>ALCAP</b>	Generic name for the transport signalling protocols used to set-up and tear-down transport bearers.
<b>Cell</b>	A cell is a geographical area that can be identified by a User Equipment from a (cell) identification that is broadcast from one <i>UTRAN Access Point</i> A Cell is either FDD or TDD mode.
<b>Iu</b>	Interconnection point between the RNS and the Core Network. It is also considered as a reference point.
<b>Iub</b>	Interface between the RNC and the Node B.
<b>Iur</b>	A logical interface between two RNCs. Whilst logically representing a point to point link between RNCs, the physical realisation may not be a point to point link.
<b>Logical Model</b>	A Logical Model defines an abstract view of a network or network element by means of information objects representing network element, aggregations of network elements, the topological relationship between the elements, endpoints of connections (termination points), and transport entities (such as connections) that transport information between two or more termination points. The information objects defined in the Logical Model are used, among others, by connection management functions. In this way, a physical implementation independent management is achieved.
<b>Node B</b>	A logical node responsible for radio transmission / reception in one or more cells to/from the UE. Terminates the Iub interface towards the RNC.
<b>Radio Network Controller</b>	This equipment in the RNS is in charge of controlling the use and the integrity of the radio resources.
<b>Controlling RNC</b>	A role an RNC can take with respect to a specific set of Node B's. There is only one Controlling RNC for any Node B. The Controlling RNC has the overall control of the logical resources of its node B's.
<b>Radio Network Subsystem</b>	Either a full network or only the access part of a UMTS network offering the allocation and the release of specific radio resources to establish means of connection in between an UE and the UTRAN. A Radio Network Subsystem contains one RNC and is responsible for the resources and transmission/reception in a set of cells.
<b>Serving RNS</b>	A role an RNS can take with respect to a specific connection between an UE and UTRAN. There is one Serving RNS for each UE that has a connection to UTRAN. The Serving RNS is in charge of the radio connection between a UE and the UTRAN. The Serving RNS terminates the Iu for this UE.
<b>Drift RNS</b>	The role an RNS can take with respect to a specific connection between an UE and UTRAN. An RNS that supports the Serving RNS with radio resources when the connection between the



UTRAN and the UE need to use cell(s) controlled by this RNS is referred to as Drift RNS

**Radio Access Network Application Part**

Radio Network Signalling over the Iu.

**Radio Network Subsystem Application Part**

Radio Network Signalling over the Iur.

**RRC Connection**

A point-to-point bi-directional connection between RRC peer entities on the UE and the UTRAN sides, respectively. An UE has either zero or one RRC connection.

**User Equipment**

A Mobile Equipment with one or several UMTS Subscriber Identity Module(s).

**UMTS Terrestrial Radio Access Network**

UTRAN is a conceptual term identifying that part of the network which consists of RNCs and Node Bs between Iu and Uu. The concept of UTRAN instantiation is currently undefined.

**UTRAN Access Point**

A conceptual point within the UTRAN performing radio transmission and reception. A UTRAN access point is associated with one specific *cell*, i.e. there exists one UTRAN access point for each cell. It is the UTRAN-side end point of a *radio link*.

**Radio Link**

A "radio link" is a logical association between a single User Equipment and a single UTRAN access point. Its physical realization comprises one or more radio bearer transmissions.

**Uu**

The Radio interface between UTRAN and the User Equipment.

**RAB sub-flows**

A Radio Access Bearer can be realised by UTRAN through several sub-flows. These sub-flows correspond to the NAS service data streams that have QoS characteristics that differ in a predefined manner within a RAB e.g. different reliability classes. RAB sub-flows have the following characteristics:

1. The sub-flows of a RAB are established and released at the RAB establishment and re-lease, respectively
2. The sub-flows of a RAB are submitted and delivered together at the RAB SAP
3. The sub-flows of a RAB are carried over the same Iu transmission connection
4. The sub-flows of a RAB are organised in a predefined manner at the SAP and over the Iu interface. The organisation is imposed by the NAS as part of its co-ordination responsibility.

**Coordinated DCHs**

Dedicated transport channels transporting information for different RAB subflows belonging to one and the same RAB. Coordinated DCHs are always established and released in combination. Coordinated DCHs cannot be operated on individually e.g. if the establishment of one DCH fails, the establishment of all other coordinated DCHs shall be terminated unsuccessfully and the establishment of the RAB fails.

## 3.2 Abbreviations

CN	Core Network
DCH	Dedicated Channel
DL	Downlink
DRNS	Drift RNS
FACH	Forward Access Channel
GTP	GPRS Tunnelling Protocol
MAC	Medium Access Control
NAS	Non Access Stratum

NBAP	Node B Application Protocol
PCH	Paging Channel
QoS	Quality of Service
RAB	Radio Access Bearer
RACH	Random Access Channel
RANAP	Radio Access Network Application Part
RNC	Radio Network Controller
RNS	Radio Network Subsystem
RNSAP	Radio Network Subsystem Application Part
RNTI	Radio Network Temporary Identity
SRNS	Serving RNS
UE	User Equipment
UL	Uplink
UMTS	Universal Mobile Telecommunication System
USIM	UMTS Subscriber Identity Module
UTRAN	UMTS Terrestrial Radio Access Network

## 3.3 Notation

Parts of the document apply only to one mode, FDD or TDD. Any such area will be tagged by [FDD — xxxxxxxxx] and [TDD — yyyyyyyyyyy] respectively. The tag applies to the text until the closing bracket.

---

## 4 General principles

The general principles guiding the definition of UTRAN Architecture as well as the UTRAN interfaces are the following :

- Logical separation of signalling and data transport networks
- UTRAN and CN functions are fully separated from transports functions. Addressing scheme used in UTRAN and CN shall not be tied to the addressing schemes of Transport functions. The fact that some UTRAN or CN function resides in the same equipment as some transport functions does not make the transport functions part of the UTRAN or the CN.
- Macro diversity (**FDD only**) is fully handled in the UTRAN
- Mobility for RRC connection is fully controlled by the UTRAN.  
*Note : Handover to other Access Networks is FFS.*
- When defining the UTRAN interfaces the following principles were followed :The functional division across the interfaces shall have as few options as possible.
- Interfaces should be based on a logical model of the entity controlled through this interface

Transport Network Control Plane is a functional plane in the interfaces protocol structure that is used for the transport bearer management. The actual signalling protocol that is in use within the Transport Network Control Plane depends on the underlying transport layer technology. The intention is not to specify a new UTRAN specific Application Part for the Transport Network Control Plane but to use signalling protocols standardised in other groups (if needed) for the applied transport layer technology.

---

## 5 UMTS General architecture

### 5.1 Overview

Figure 1. shows a simplified UMTS architecture with the external reference points and interfaces to the UTRAN. The architecture is based on document [1].

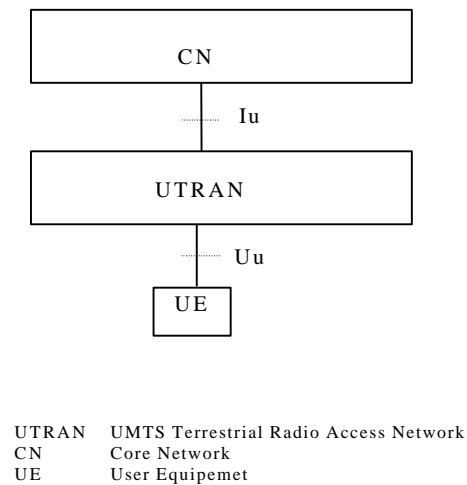

**Figure 1. UMTS Architecture**

## 5.2 General protocols architecture

The protocols over Uu and Iu interfaces are divided into two structures:

- User plane protocols**  
 These are the protocols implementing the actual radio access bearer service, i.e. carrying user data through the access stratum.
- Control plane protocols**  
 These are the protocols for controlling the radio access bearers and the connection between the UE and the network from different aspects (including requesting the service, controlling different transmission resources, handover & streamlining etc.). Also a mechanism for transparent transfer of NAS messages is included.

### 5.2.1 User plane

The radio access bearer service is offered from SAP to SAP by the Access Stratum. The figure below shows the protocols on the Uu and Iu interfaces that linked together provide this radio access bearer service.

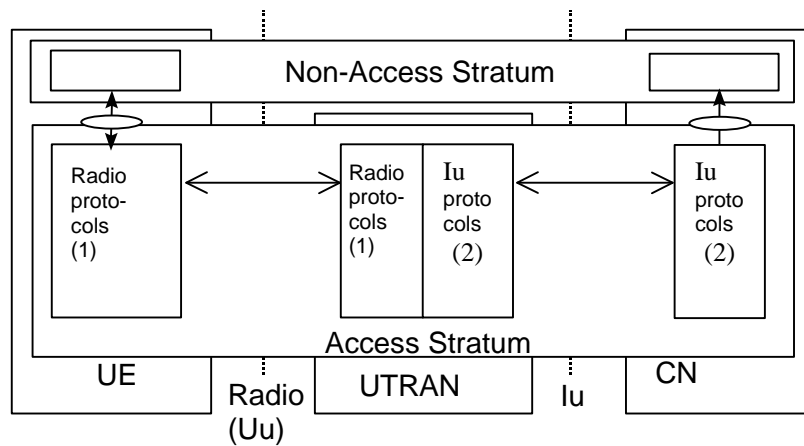

Figure 2. Iu and Uu User plane

(1) To be defined by TSG RAN WG2

(2) The protocols are defined in documents S3.1x (description of Iu interface).

### 5.2.2 Control plane

The figure below shows the control plane (signalling) protocol stacks on Iu and Uu interfaces.

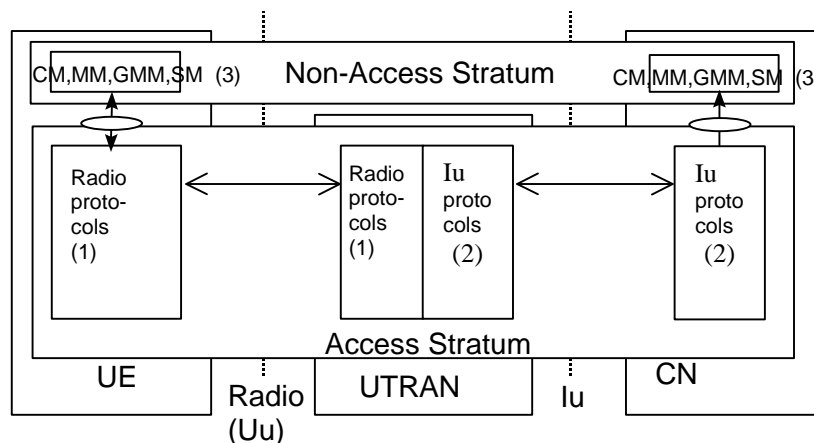

Figure 3. Iu and Uu Control plane

(1) To be defined by TSG RAN WG2 group

(2) The protocol is defined in documents S3.1x.(Description of Iu interface).(3) **CM,MM,GMM,SM**: This exemplifies a set of NAS control protocols between UE and CN. There may be different NAS protocol stacks in parallel. The evolution of the protocol architecture for these protocols is FFS.

*Note : Both the Radio protocols and the Iu protocols contain a mechanism to transparently transfer NAS messages.*

## 6 UTRAN Architecture

The UTRAN consists of a set of Radio Network Subsystems connected to the Core Network through the Iu.

A RNS consists of a Radio Network Controller and one or more abstract entities currently called Node B. Node B are connected to the RNC through the Iub interface.

A Node B can support FDD mode, TDD mode or dual-mode operation.

The RNC is responsible for the Handover decisions that require signalling to the UE.

The RNC comprises a combining/splitting function to support macro diversity between different Node B.

The Node B supporting the FDD mode can comprise an optional combining/splitting function to support macro diversity inside a Node B.

Inside the UTRAN, the RNCs of the Radio Network Subsystems can be interconnected together through the Iur. Iu(s) and Iur are logical interfaces. Iur can be conveyed over physical direct connection between RNCs or via any suitable transport network.

The UTRAN architecture is shown in Figure 4.

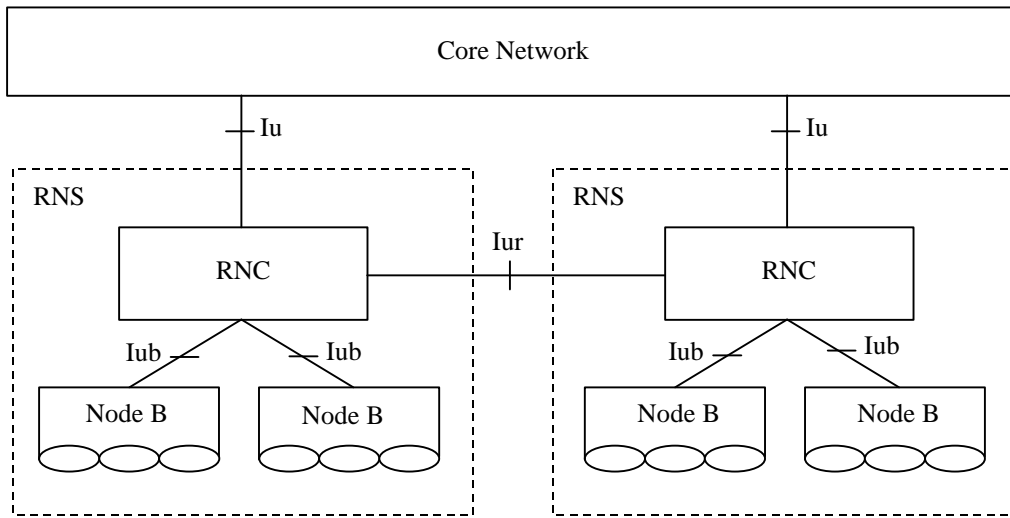

Figure 4. UTRAN Architecture

Each RNS is responsible for the resources of its set of cells.

For each connection between a User Equipment and the UTRAN, One RNS is the Serving RNS. When required, Drift RNSs support the Serving RNS by providing radio resources as shown in Figure 5. The role of an RNS (Serving or Drift) is on a per connection basis between a UE and the UTRAN.

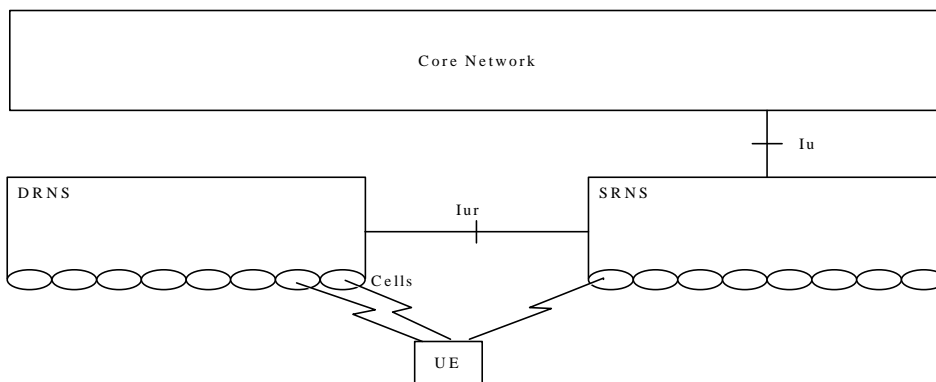

Figure 5. Serving and Drift RNS

## 6.4 UTRAN Identifiers

### 6.4.1 PLMN Identifier

A Public Land Mobile Network is uniquely identified by its PLMN identifier. PLMN-Id is made of Mobile Country Code (MCC) and Mobile Network Code (MNC).

**PLMN-Id = MCC + MNC**

### 6.4.2 CN Domain Identifier

A CN Domain Edge Node is identified within UTRAN by its CN Domain Identifier. The CN Domain identifier is used over UTRAN interfaces to identify a particular CN Domain Edge Node for relocation purposes. The CN Domain identifier is made of the PLMN-Id and of the LAC or RAC of the first accessed cell in the target RNS.

The two following CN Domains Identifiers are defined:

**CN CS Domain-Id = PLMN-Id + LAC**

**CN PS Domain-Id = PLMN-Id + LAC + RAC**

### 6.4.3 RNC Identifier

An RNC node is uniquely identified within UTRAN by its RNC Identifier (RNC-Id). RNC-Id together with the PLMN identifier is used to globally identify the RNC. RNC-Id or the RNC-Id together with the PLMN-Id is used as RNC identifier in UTRAN Iub, Iur and Iu interfaces. SRNC-Id is the RNC-Id of the SRNC. C-RNC-Id is the RNC-Id of the controlling RNC. D-RNC-Id is the RNC Id of the drift RNC.

**Global RNC-Id = PLMN-Id + RNC-Id**

### 6.4.4 Cell Identifier

The Cell identifier (C-Id) is used to uniquely identify a cell within an RNS. The Cell-Id together with the identifier of the controlling RNC (CRNC-Id) constitutes the UTRAN Cell Identity (UC-Id) and is used to identify the cell uniquely within UTRAN. UC-Id or C-Id is used to identify a cell in UTRAN Iub, Iur and Iu interfaces.

**UC-Id = RNC-Id + C-Id**

### 6.4.5 UE Identifiers

*Note : This RNTI definition and usage needs to be confirmed by 3GPP TSG RAN WG2.*

Radio Network Temporary Identities (RNTI) are used as UE identifiers within UTRAN and in signalling messages between UE and UTRAN.

Three types of RNTI exist;

1. Serving RNC RNTI (s-RNTI)
2. Drift RNC RNTI (d-RNTI)
3. Controlling RNC RNTI(c-RNTI)

**s-RNTI is used**

- by UE to identify itself to the Serving RNC
- by SRNC to address the UE
- by DRNC to identify the UE to Serving RNC.

s-RNTI is allocated for all UEs having a RRC connection, it is allocated by the Serving RNC and it is unique within the Serving RNC. s-RNTI is reallocated always when the Serving RNC for the RRC connection is changed.

#### **d-RNTI is used**

- by serving RNC to identify the UE to Drift RNC.

*Note: The d-RNTI is never used on Uu.*

d-RNTI is allocated by drift RNC upon drift UE contexts establishment and it shall be unique within the drift RNC. Serving RNC shall know the mapping between s-RNTI and the d-RNTIs allocated in Drift RNCs for the same UE. Drift RNC shall know the s-RNTI and SRNC-ID related to existing d-RNTI within the drift RNC.

#### **c-RNTI is used**

- by UE to identify itself to the controlling RNC
- by controlling RNC to address the UE.

c-RNTI is allocated by controlling RNC upon UE accessing a new cell. C-RNTI shall be unique within the accessed cell. Controlling RNC shall know the d-RNTI associated to the c-RNTI within the same logical RNC (if any).

Each RNC has a unique identifier within the UTRAN part of the PLMN, denoted by RNC identifier (RNC-ID). This identifier is used to route UTRAN interface messages to correct RNC. RNC-ID of the serving RNC together with the s-RNTI is a unique identifier of the UE in the UTRAN part of the PLMN.

### **6.1.5.4 Usage of RNTI**

S-RNTI together with the RNC-ID is used as a UE identifier for the first cell access (at cell change) when a RRC connection exists for this UE and for UTRAN originated paging including associated response messages on the air interface. RNC-ID is used by Controlling RNC to route the received uplink messages towards the Serving RNC.

*Note : For the initial access two different methods of identification, a random number and a unique core network UE identifier are under consideration.*

C-RNTI is used as a UE identifier in all other DCCH/DTCH common channel messages on air interface

## **6.1.6 Identifiers for dedicated resources within UTRAN**

### **6.1.6.1 Radio Network Control Plane identifiers**

Each addressable object in each reference point has an application part level identifier. This identifier is allocated autonomously by the entity responsible for initiation of the setup of the object. This application part identifier will be used as a reference to the object that is setup. Both ends of the reference point shall memorise the AP Identifier during the lifetime of the object. Application part identifier can be related to a specific ALCAP identifier and that relationship shall also be memorised by both ends.

Table below lists the basic AP level identifiers in each reference point.

Object	Identifier	Abbreviation	Valid for
Radio Access Bearer	Radio Access Bearer ID	RAB-ID	Iu
Dedicated Transport channel	DCH-ID	DCH-ID	Iur, Iub

### 6.1.6.2 Transport Network Control Plane identifiers

ALCAP identifier is used only in Transport Network Control plane (ALCAP protocol, if exist) and may be used in User Plane in the actual data transmission using the transport link. ALCAP identifier identifies the transport link according to the naming conventions defined for the transport link type in question. Both ends of the reference point of the ALCAP shall memorise the ALCAP identifier during the lifetime of the transport link. Each ALCAP identifier can be binded to an Application Part identifier.

Following table indicates examples of the identifiers used for different transmission link types.

Transmission link type	ALCAP Identifier
AAL2	AAL2 Path ID + CID
GTP over IP	IP address + GTP identifier (ffs.)

### 6.1.6.3 Binding identifier

Binding Identifier is used to initialise the linkage between ALCAP and Application Part (RANAP, RNSAP, NBAP) identifiers. Binding identifier can be used both in Radio Network Control plane Application Part protocols and in Transport Network Control Plane's ALCAP protocol.

Binding ID binds the Radio and Transport Network Control plane identifiers together. To ensure maximal independence of those two planes, the binding ID should be used only when necessary: Binding ID shall thus be used only in Radio Network Control plane Application Part messages in which a new association between the planes is created and in ALCAP messages creating new transmission links.

Binding ID for each transmission link shall be allocated before the setup of that transmission link. Reserved Binding IDs and the associated transport link shall be memorised by both peers of each reference point.

The Binding ID is sent on one direction using the Application Part protocol and is return in the other direction by the ALCAP protocol.

The binding identity shall already be assigned and tied to a radio application procedure when the first ALCAP message is received in a node.

Figure 6. illustrates how application instances of the Radio Network Control Plane and instances of the Transport Network Plane are linked together through the Binding Identifier in the set-up phase:



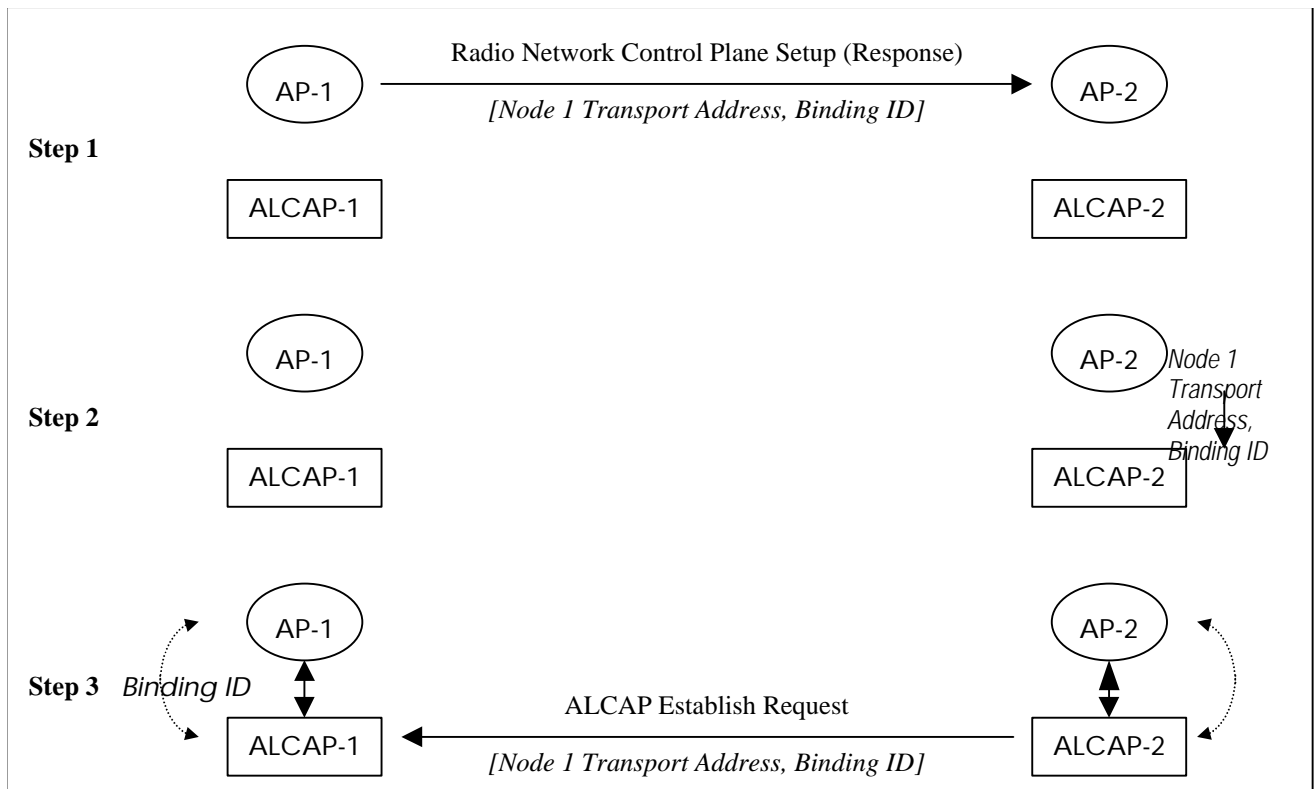

**Figure 6. Usage of Binding ID**

- Step 1: Application Part AP-1 assign the Binding Identifier and sends a Radio Network Control Plane Set-up (Response) message (which of the two messages depends on the involved interface - Iu/Iur or Iub). The message contains the originating node Transport layer address and the Binding Identifier.
- Step 2: Among reception of the Radio Network Control Plane Set-up message, the peer entity AP-2 requests to ALCAP-2 to establish a transmission link. The Binding Identifier is passed to ALCAP-2
- Step 3: ALCAP-2 sends an ALCAP Establish Request to the peer entity ALCAP-1. The message contains the Binding Identifier. The Binding Identifier allows correlating the incoming transport connection with the Application Part transaction in step 1.

The following table indicates the binding identifier allocating entity in each interface.

Reference point	Allocating entity	Application part message including Binding-ID
Iu	CN	Request from CN
Iur	DRNC	Response to the request from SRNC
Iub	Node-B	Response to the request from DRNC

## 6.2 Transport Addresses

The transport layer address parameter is transported in the radio network application signalling procedures that result in establishment of transport bearer connections.

The transport layer address parameter shall not be interpreted in the radio network application pro-tocols and reveal the addressing format used in the transport layer.

---

## 7 UTRAN Functions description

### 7.1 List of functions

*Note : This list of functions, their classification and definitions is an initial list, classification and definitions that will be further refined.*

- Functions related to overall system access control
  - Admission Control
  - Congestion Control
  - System information broadcasting
- Functions related to security and privacy
  - Use of Temporary Identifier
  - Radio channel ciphering
  - Radio channel deciphering
- Functions related to handover
  - Radio environment survey
  - Handover decision
  - Macro-diversity control (FDD only)
  - Handover Control
  - Handover execution
  - Handover completion
  - SRNS Relocation
  - Inter-System handover
- Functions related to radio resource management and control
  - Radio bearer connection set-up and release (Radio Bearer Control)
  - Reservation and release of physical radio channels
  - Allocation and deallocation of physical radio channels
  - Packet data transfer over radio function
  - RF power control
  - RF power setting
  - Radio channel coding
  - Radio channel decoding
  - Channel coding control
  - Initial (random) access detection and handling

- CN Distribution function for Non Access Stratum messages
- [Dynamic Channel Allocation \(DCA\) \(TDD only\)](#)

## 7.2 Functions description

### 7.2.1 Functions related to overall system access control

System access is the means by which a UMTS user is connected to the UMTS in order to use UMTS services and/or facilities. User system access may be initiated from either the mobile side, e.g. a mobile originated call, or the network side, e.g. a mobile terminated call.

#### 7.2.1.1 Admission Control

The purpose of the admission control is to admit or deny new users, new radio access bearers or new radio links (for example due to handover). The admission control should try to avoid overload situations and base its decisions on interference and resource measurements. The admission control is employed at for example initial UE access, RAB assignment/reconfiguration and at handover. These cases may give different answers depending on priority and situation.

*Note : This admission Control function is related to Radio Resources*

Admission control in a DRNC is implicitly invoked during radio link setup/modify.

Information on UL interferences and DL power on cells controlled by the DRNC should be available across Iur.

Additional information exchanges between admission control functions located in different RNCs are for further study.

The Admission Control function based on UL interference and DL power is located in the Controlling RNC.

The Node B shall be able to report UL interference measurements and DL power information over Iub.

The Controlling RNC controls this reporting function, i.e. if these information need to be reported and the period of these reports.

*Note : Other parameters for Admission Control are FFS.*

#### 7.2.1.2 Congestion Control

The task of congestion control is to monitor, detect and handle situations when the system is reaching a near overload or an overload situation with the already connected users. This means that some part of the network has run out, or will soon run out of resources. The congestion control should then bring the system back to a stable state as seamless as possible.

*Note : This admission Control function is related to Radio Resources*

#### 7.2.1.3 System information broadcasting

This function provides the mobile station with the information which is needed to camp on a cell and to set up a connection in idle mode and to perform a handover or route packets in communication mode. The tasks may include :

- access rights
- frequency bands used
- configuration of logical channels, PCH, FACH and RACH channel structure of the cell etc.
- network and cell identities
- information for location registration purposes

- UE idle mode cell selection and cell re-selection criteria
- UE transmission power control information
- UE access and admission control information

Because of its close relation to the basic radio transmission and the radio channel structure, the basic control and synchronisation of this function should be located in UTRAN.

## 7.2.2 Functions related to security and privacy

### 7.2.2.1 Use of Temporary Identifier

UTRAN shall, as far as possible, use a temporary identifier instead of the permanent CN assigned identity (e.g. IMSI, International Mobile Subscriber Identity).

This function is located in the UE and in the UTRAN.

### 7.2.2.2 Radio channel ciphering

This function is a pure computation function whereby the radio transmitted data can be protected against a non-authorised third-party. Ciphering may be based on the usage of a session-dependent key, derived through signalling and/or session dependent information.

This function is located in the UE and in the UTRAN.

### 7.2.2.3 Radio channel deciphering

This function is a pure computation function which is used to restore the original information from the ciphered information. The deciphering function is the complement function of the ciphering function, based on the same ciphering key.

This function is located in the UE and in the UTRAN.

## 7.2.3 Functions related to handover

### 7.2.3.1 Radio environment survey

This function performs measurements on radio channels (current and surrounding cells) and translates these measurements into radio channel quality estimates. Measurements may include :

1. received signal strengths (current and surrounding cells),
2. estimated bit error ratios, (current and surrounding cells),
3. estimation of propagation environments (e.g. high-speed, low-speed, satellite, etc.),
4. transmission range (e.g. through timing information),
5. Doppler shift,
6. synchronisation status,
7. Received interference level,
8. Total DL transmission power per cell.

In order for these measurements and the subsequent analysis to be meaningful, some association between the measurements and the channels to which they relate should be made in the analysis. Such association may include the use of identifiers for the network, the base station, the cell (base station sector) and/or the radio channel.

This function is located in the UE and in the UTRAN.

### 7.2.3.2 Handover decision

This function consists of gathering estimates of the quality of the radio channels (including estimates from surrounding cells) from the measuring entities and to assess the overall quality of service of the call. The overall quality of service is compared with requested limits and with estimates from surrounding cells. Depending on the outcome of this comparison, the *macro-diversity control function* or the *handover control function* may be activated.

This function may also include functionalities to assess traffic loading distribution among radio cells and to decide on handing over traffic between cells for traffic reasons.

The location of this function is depending on the handover principle chosen.

- if network only initiated handover, this function is located in the RNC;
- if mobile only initiated handover, this function is located in the UE;
- if both the mobile and the network can initiate handover, this function will be located in both the RNC and the UE.

### 7.2.3.3 Macro-diversity control (FDD only)

Upon request of the *Handover Decision function*, this function controls the duplication/ replication of information streams to receive/ transmit the same information through multiple physical channels (possibly in different cells) from/ towards a single mobile terminal.

This function also controls the combining of information streams generated by a single source (diversity link), but conveyed via several parallel physical channels (diversity sub-links). Macro diversity control should interact with channel coding control in order to reduce the bit error ratio when combining the different information streams. This function controls macro-diversity execution which is located at the two endpoints of the connection element on which macro-diversity is applied (diversity link), that is at the access point and also at the mobile termination .

In some cases, depending on physical network configuration, there may be several entities which combine the different information streams, e.g. one entity combines information streams on radio signal basis, another combines information streams on wireline signal basis.

This function is typically located in the UTRAN. However, depending on the physical network architecture, some bit stream combining function within the CN may have to be included in the control.

A DRNS may perform macro-diversity combining/splitting of data streams communicated via its cells. The SRNS performs macro-diversity combining/splitting of Iur data streams received from/sent to DRNS(s), and data streams communicated via its own cells.

When requesting the addition of a new cell for a UE-UTRAN connection, the RNC of the SRNS (i.e. the SRNC) can explicitly request to the RNC of the DRNS (i.e. the DRNC) a new Iur data stream, in which case the macro-diversity combining and splitting function within the DRNS is not used for that cell. Otherwise, the DRNS takes the decision

The internal DRNS handling of the macro-diversity combining (respectively splitting) of Iub (respectively Iur) DCH frames is controlled by the DRNS.

Node B may perform macro-diversity combining/splitting of data streams communicated via its cells. The Controlling RNC performs macro-diversity combining/splitting of Iub data streams received from/sent to several Node B(s).

When requesting the addition of a new cell for a UE-UTRAN connection, the Controlling RNC can explicitly request to the Node B a new Iub data stream, in which case the macro-diversity combining and splitting function within the Node B is not used for that cell. Otherwise, the Node B takes the decision whether macro-diversity combining and splitting function is used inside the Node B for that cell i.e. whether a new Iub data stream shall be added or not.

The internal Node B handling of the macro-diversity combining/splitting of radio frames is controlled by the Node B.

### 7.2.3.4 Handover Control

In the case of switched handover, this function is responsible for the overall control of the handover execution process. It initiates the handover execution process in the entities required and receives indications regarding the results.

Due to the close relationship with the radio access and the Handover Decision function, this function should be located in the UTRAN.

### 7.2.3.5 Handover execution

This function is in control of the actual handing over of the communication path. It comprises two sub-processes: *handover resource reservation* and *handover path switching*. The *handover resource reservation* process will reserve and activate the new radio and wireline resources that are required for the handover. When the new resources are successfully reserved and activated, the *handover path switching* process will perform the final switching from the old to the new resources, including any intermediate path combination required, e.g. radio link addition and radio link deletion in the soft handover case.

This function is located in the UTRAN for UTRAN internal path switching and in the CN for CN path switching.

### 7.2.3.6 Handover completion

This function will free up any resources that are no longer needed. A re-routing of the call may also be triggered in order to optimise the new connection.

This function is located both in the UTRAN and in the CN.

### 7.2.3.7 SRNS Relocation

The SRNS Relocation function coordinates the activities when the SRNS role is to be taken over by another RNS. SRNS relocation implies that the Iu interface connection point is moved to the new RNS.

This function is located in the RNC and the CN.

#### 7.2.3.7.1 Access Network Triggered SRNS Relocation

One Access Network triggered function needed over the Iu interface is the function for SRNS Relocation. SRNS Relocation needs support from the Core Network to be executed.

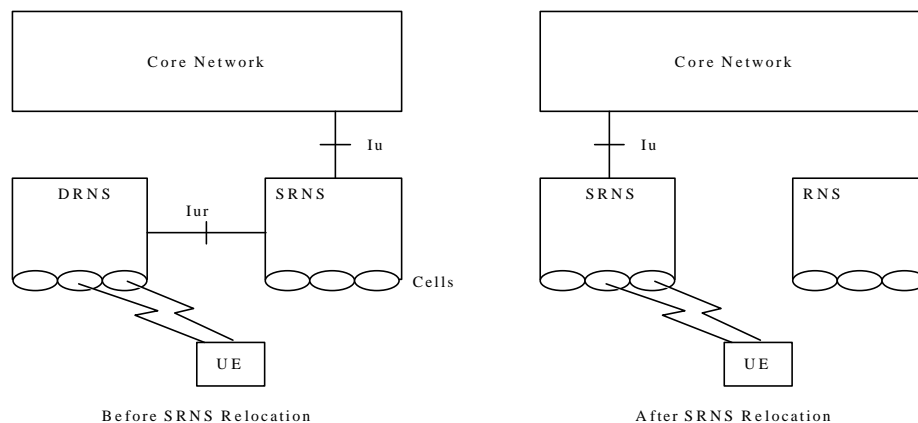

**Figure 7. Serving RNS Relocation**

[FDD] For the cases where handover can be performed independently from SRNS Relocation, the algorithm for triggering the SRNS relocation is not specified.]

[FDD — The specification of Iur Interface shall allow the support of soft handover throughout the UTRAN of PLMN without performing SRNS relocation.]

#### 7.2.3.7.2 Core Network Triggered SRNS Relocation

For Further Studies

### 7.2.3.8 Inter-System handover

The Inter-system handover function enables handover to and from e.g. GSM BSS, PDC system.

This function is located in the UTRAN, the UE and the CN.

#### 7.2.3.8.1 Handover from UMTS to GSM

In case of inter-system environment, UTRAN transmits a list of GSM neighbour cells to the mobile. Based on measurements made by the dual mode UE, the RNC can decide to perform a handover to GSM cells.

After this decision, RNC sends one target cell in Hard Handover Required message to the MSC. Since, the MSC knows the complete configuration on a cell basis of each BSC connected to him, he can transfer as in GSM the Request to handover to the target BSC. The BSC activates a new channel on the target cell and prepare Handover Command message which will be transferred to the UE transparently through the RNC. After the successful execution of the handover, resources on source RNC are released.

- Handover from UMTS to GSM may need service re-negotiation: this point is FFS

#### 7.2.3.8.2 Handover from GSM to UMTS

Handover from GSM to UMTS may occur for two reasons:

- radio coverage reason
- service reason : this point is FFS

In case of inter-system environment, BSC broadcasts a list of UMTS neighbour cells in System Information message. A dual mode UE arriving in boarder of GSM coverage will perform measurements on UMTS cells. Based on these measurements, the BSC can decide to perform a handover to UMTS cells

Then, the BSC<sup>1</sup> sends a Handover Required message with a cell list to the MSC. The MSC is not able to determine the location of the requested UMTS cells only with cell identity. At least, source BSC shall identify a UMTS cell with RNC and cell identifiers, so that the MSC knows to which RNC, he have to send Hard Handover Request message. On receipt of this message, the RNC activates a channel on the requested cell and prepares Handover Command which is sent transparently to the UE through the BSC. After the successful execution of the handover, resources on source BSC are released.

## 7.2.4 Functions related to radio resource management and control

*Radio resource management* is concerned with the allocation and maintenance of radio communication resources. UMTS radio resources must be shared between circuit transfer mode services and packet transfer modes services (i.e. Connection-oriented and/or connectionless-oriented services).

### 7.2.4.1 Radio bearer connection set-up and release (Radio Bearer Control)

This function is responsible for the control of connection element set-up and release in the radio access sub network. The purpose of this function is

1. to participate in the processing of the end-to-end connection set-up and release,
2. and to manage and maintain the element of the end-to-end connection, which is located in the radio access sub network.

In the former case, this function will be activated by request from other functional entities at call set-up/release. In the latter case, i.e. when the end-to-end connection has already been established, this function may also be invoked to cater for in-call service modification or at handover execution. This function interacts with the *reservation and release of physical (radio) channels* function.

---

<sup>1</sup> The behaviour of the BSC is given as an example since it is out of the scope of ARC EG

This function is located both in the UE and in the RNC.

#### 7.2.4.2 Reservation and release of physical radio channels

This function consists of translating the connection element set-up or release requests into physical radio channel requests, reserving or releasing the corresponding physical radio channels and acknowledging this reservation/ release to the requesting entity.

This function may also perform physical channel reservation and release in the case of a handover. Moreover, the amount of radio resource required may change during a call, due to service requests from the user or macro-diversity requests. Therefore, this function must also be capable of dynamically assigning physical channels during a call.

*Note: This function may or may not be identical to the function allocation and deallocation of physical radio channels. The distinction between the two functions is required e.g. to take into account sharing a physical radio channel by multiple users in a packet data transfer mode.*

This function is located in the UTRAN.

#### 7.2.4.3 Allocation and deallocation of physical radio channels

This function is responsible, once physical radio channels have been reserved, for actual physical radio channel usage, allocating or deallocating the corresponding physical radio channels for data transfer. Acknowledging this allocation/ deallocation to the requesting entity is for further study.

*Note: This function may or may not be identical to the function reservation and release of physical radio channels. The distinction between the two functions is required e.g. to take into account sharing a physical radio channel by multiple users in a packet data transfer mode.*

This function is located in the UTRAN.

#### 7.2.4.4 Allocation of Downlink Channelisation Codes

[Editorial remark: Text updated to match both FDD and TDD.]

For FDD, aallocation of downlink channelisation codes of cells belonging to DRNS is performed in DRNS.

*Editors note: Note that this does not imply that the signalling of the code allocation to the UE must be done from the DRNS.*

For FDD, aallocation of downlink channelisation codes of cells belonging to Node B is performed in the Controlling RNC.

For TDD, allocation of Physical Channels of cells belonging to DRNS is performed in DRNS, and allocation of Physical Channels of cells belonging to Node B is performed in the Controlling RNC.

#### 7.2.4.5 Packet data transfer over radio function

This function provides packet data transfer capability across the UMTS radio interface. This function includes procedures which:

1. provide packet access control over radio channels,
2. provide packet multiplexing over common physical radio channels,
3. provide packet discrimination within the mobile terminal,
4. provide error detection and correction,
5. provide flow control procedures.

This function is located in both the UE and in the UTRAN.

It encompasses :



1. Channel type switching : UTRAN shall have the possibility to dynamically, during an RRC connection, switch between a Common Transport and a Dedicated Transport Channel. This to optimise the radio resource utilisation and to achieve the QoS requested by the packet data user.
2. Channel rate modification : UTRAN shall have the possibility to dynamically, during an RRC connection, modify the channel rate of a Dedicated Transport Channel. This to optimise the radio resource utilisation and to achieve the QoS requested by the packet data user.
3. Packet scheduling : When performing data transfer, it shall be possible to schedule data transmissions according to QoS.
4. Retransmission : For assured mode radio access bearers, UTRAN shall support retransmission of unacknowledged data over the radio interface. This, in order to assure a certain packet loss probability.
5. Packet discard : If, for example, the communication over the radio interface fails and parts of an Access Stratum SDU (e.g. an IP packet) are lost, or due to congestion within UTRAN a part of an Access Stratum SDU is dropped, UTRAN shall discard the whole Access Stratum SDU. This is to ensure that radio resources are not unnecessarily wasted. It is expected that higher layers (transport protocols) will perform the necessary retransmissions.
6. Avoidance of IP fragmentation; UTRAN shall be able to handle Access Stratum SDUs up to a size which is large enough to avoid IP fragmentation in most cases.

#### 7.2.4.6 RF power control

This group of functions controls the level of the transmitted power in order to minimise interference and keep the quality of the connections. It consist of the following functions: UL Outer Loop Power Control, DL Outer Loop Power Control, UL Inner Loop Power Control, DL Inner Loop Power Control, UL Open Loop Power Control and DL Open Loop Power Control.

##### 7.2.4.6.1 UL OUTER LOOP POWER CONTROL

The UL Outer Loop Power Control located in the SRNC sets the target quality value for the UL Inner Loop Power Control located in Node B. It receives input from quality estimates of the transport channel. The UL outer loop power control is mainly used for a long-term quality control of the radio channel.

This function is located in the UTRAN.

If the connection involves both a SRNS and a DRNS the function UL Outer Loop Power Control (located in the SRNC) sets the target quality for the UL Inner Loop Power Control function (located in Node B). Additional quality information for the case when macro diversity combining is performed in DRNC is for further study.

*Note : some additional function is needed for resource negotiation between the SRNS and the DRNS across the Iur. This is FFS.*

##### 7.2.4.6.2 DL OUTER LOOP POWER CONTROL

The DL Outer Loop Power Control sets the target quality value for the DL inner loop power control. It receives input from quality estimates of the transport channel, measured in the UE. The DL outer loop power control is mainly used for a long-term quality control of the radio channel.

This function is located mainly in the UE, but some control parameters are set by the UTRAN.

The SRNC, regularly (or under some algorithms), sends the target down link power range based on the measurement report from UE.

##### 7.2.4.6.3 UL INNER LOOP POWER CONTROL

The UL Inner Loop Power Control sets the power of the uplink dedicated physical channels. It receives the quality target from UL Outer Loop Power Control and quality estimates of the uplink dedicated physical control channel. The power control commands are sent on the downlink dedicated physical control channel to the UE.

This function is located in both the UTRAN and the UE.

#### ~~7.2.4.6.4~~DL INNER LOOP POWER CONTROL

The DL Inner Loop Power Control sets the power of the downlink dedicated physical channels. It receives the quality target from DL Outer Loop Power Control and quality estimates of the downlink dedicated physical control channel. The power control commands are sent on the uplink dedicated physical control channel to the UTRAN.

This function is located in both the UTRAN and the UE.

#### ~~7.2.4.6.5~~UL OPEN LOOP POWER CONTROL

The UL Open Loop Power Control sets the initial power of the UE, i.e. at random access. The function uses UE measurements and broadcasted cell/system parameters as input.

This function is located in both the UTRAN and the UE.

#### ~~7.2.4.6.6~~DL OPEN LOOP POWER CONTROL

The DL Open Loop Power Control sets the initial power of downlink channels. It receives downlink measurement reports from the UE.

This function is located in both the UTRAN and the UE.

#### ~~7.2.4.7~~Radio channel coding

This function introduces redundancy into the source data flow, increasing its rate by adding information calculated from the source data, in order to allow the detection or correction of signal errors introduced by the transmission medium. The channel coding algorithm(s) used and the amount of redundancy introduced may be different for the different types of logical channels and different types of data.

This function is located in both the UE and in the UTRAN.

#### ~~7.2.4.8~~Radio channel decoding

This function tries to reconstruct the source information using the redundancy added by the channel coding function to detect or correct possible errors in the received data flow. The channel decoding function may also employ a priori error likelihood information generated by the demodulation function to increase the efficiency of the decoding operation. The channel decoding function is the complement function to the channel coding function.

This function is located in both the UE and in the UTRAN.

#### ~~7.2.4.9~~Channel coding control

This function generates control information required by the channel coding/ decoding execution functions. This may include channel coding scheme, code rate, etc.

This function is located in both the UE and in the UTRAN.

#### ~~7.2.4.10~~Initial (random) access detection and handling

This function will have the ability to detect an initial access attempt from a mobile station and will respond appropriately. The handling of the initial access may include procedures for a possible resolution of colliding attempts, etc. The successful result will be the request for allocation of appropriate resources for the requesting mobile station.

This function is located in the UTRAN.

### 7.2.4.11 CN Distribution function for Non Access Stratum messages

[Editorial remark: The following text takes into account the changes according Tdoc R3-99638 which has been agreed with modifications, as reported in the Iu SWG report, R3-99786.]

~~In the RRC protocol, messages from the NAS shall be transparently transferred within the Access Stratum using the Direct Transfer procedure. In the two CN scenario, a distribution function in the UE and the SRNC shall handle a CN discriminator to direct messages to the appropriate NAS entity i.e. the appropriate Mobility Management instance in the UE domain and the appropriate CN domain.~~

~~In the downlink direction, the signaling bearers addressing shall be used to identify the originating CN domain (e.g. from CN node originating address). The process performed by the distribution function simply consists in adding one CN discriminator to the value corresponding to the originating CN domain and passing the NAS message to the underneath protocol layers for transparent transfer to the UE.~~

~~In the uplink direction, the process performed by the distribution function in the SRNC consists in removing the CN discriminator inserted by the peer UE function and distribute the NAS message to the corresponding RANAP instance for transfer over Iu interface.~~

~~This function is located in both the UE and in the SRNC.~~

~~In the RRC protocol, messages from the NAS shall be transparently transferred within the Access Stratum using the Direct Transfer procedure. A distribution function in the UE and the SRNC shall handle a CN domain indicator being part of the AS message to direct messages to the appropriate NAS entity i.e. the appropriate Mobility Management instance in the UE domain and the appropriate CN domain.~~

~~In the downlink direction the UE shall be provided by the SRNC with the information on the originating CN domain for the individual NAS message.~~

~~In the uplink direction, the process performed by the distribution function in the UE consists in inserting the appropriate CN domain indicator value to the AS message and the process performed by the SRNC consists in evaluating the CN domain indicator contained in the AS message and distribute the NAS message to the corresponding RANAP instance for transfer over Iu interface.~~

~~This distribution function is located in both the UE and in the SRNC.~~

### 7.2.4.12 Dynamic Channel Allocation (DCA)

DCA is used in the TDD mode. It includes Fast DCA and Slow DCA. Slow DCA is the process of assigning radio resources, including time slots, to different TDD cells according to the varying cell load. Fast DCA is the process of assigning resources to Radio Bearers, and is related to Admission Control.

## 8 Mobility Management

*Note : Location based services have not been yet considered and need further studies.*

### 8.1 Dedicated Connection

Based on [2], the UE may either have or not have a dedicated connection :

1. There exists a dedicated connection established over the Dedicated Control Service Access Point (DC-SAP) from the Access Stratum.

In this case, the CN can reach the UE by the dedicated connection SAP on the CN side, and the UTRAN has a context with the UE and CN for this particular connection. This context is erased when the connection is released. The *dedicated connection* can be initiated from the UE only.

*Editor's note : A dedicated connection is currently defined as Signalling Connection in [2]. Note that in the radio interface, dedicated or common channels can be used.*

Depending on the activity of a UE, the location of the UE is known either on cell level (higher activity) or in a larger area consisting of several cells (lower activity). This will (i) minimise the number of location update messages for moving UEs with low activity and (ii) remove the need for paging for UEs known on cell level.

2. There does not exist a dedicated connection.

In this case, the CN must reach the UE via the Notification SAP. The message sent to the UE can be a request to the UE to establish a dedicated connection. The UE is addressed with a user/terminal identity and a 'geographical area'.

## 8.2 Consequences for Mobility Handling

It is generally agreed [1] to contain radio access specific procedures within UTRAN. This means that all cell level mobility should be handled within UTRAN. Also the cell structure of the radio network should not necessarily be known outside the UTRAN.

When there exists a dedicated connection to the UE, the UTRAN shall handle the radio interface mobility of the UE. This includes procedures such as soft handover, and procedures for handling mobility in the RACH/PCH substate.

*Editor's note : Some reference will be necessary to a 3GPP TSG RAN WG2 document that defines that substate.*

When there does not exist a dedicated connection to the UE, no UE information in UTRAN is needed. In this case, the mobility is handled directly between UE and CN outside access stratum (e.g. by means of registration procedures). When paging the UE, the CN indicates a 'geographical area' that is translated within UTRAN to the actual cells that shall be paged. A 'geographical area' shall be identified in a cell-structure independent way. One possibility is the use of 'Location Area identities'.

During the lifetime of the dedicated connection, the registrations to the CN are suppressed by the UE. When a dedicated connection is released, the UE performs a new registration to the CN, if needed.

Thus, the UTRAN does not contain any permanent 'location registers' for the UE, but only temporary contexts for the duration of the dedicated connection. This context may typically contain location information (e.g. current cell(s) of the UE) and information about allocated radio resources and related connection references.

---

## 9 Synchronisation

### 9.1 SYNCHRONISATION MODEL

The Synchronisation model includes nodes and interactions in UTRAN as well as points at interactions to Core Network (CN) and User Equipment (UE).

The following model describes the interactions between nodes and defines the following terms:

- Time Alignment handling
- Frame synchronisation
- Radio Interface Synchronisation handling
- Time-of-day handling

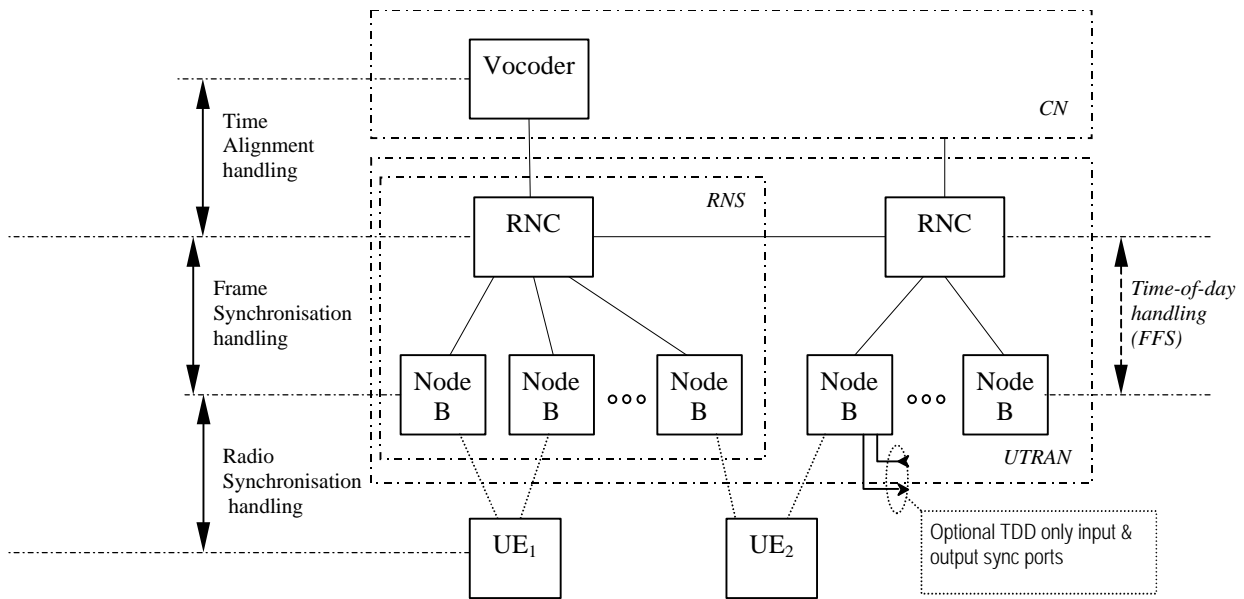

Figure 8. Synchronisation issues model.

## 9.2 Network Synchronisation

The Network Synchronisation relates to the stability of the clocks in the UTRAN. The standard will specify the performance requirements on the radio interface. Also the characteristics on the UTRAN internal interfaces, in particular Iub, need to be specified.

*Editor's note : The short-term stability (e.g. over a symbol or frame) of the Node B transmitter is an issue for the L1 EG. However, the long-term stability is related to the Node Synchronisation (see below), and may need to be specified taking the Node Synchronisation into account.*

## 9.3 Node Synchronisation

*Editor's Note: following are Editor's proposal to reflect the outcome of the Sync Ad hoc on Node Synchronisation. The text is mainly coming from Tdoc R3-99A45.*

Node Synchronisation describes how a common timing reference can be achieved between the UTRAN nodes.

Node synchronization may be used as basis for up-link and down-link frame synchronization, both ~~in up and down link~~ on UTRAN internal interfaces (Iub and Iur) and on Uu interface (TDD only). In TDD Frame synchronization is actually used within neighbouring cells to minimise cross-interference (Node B-Node B, UE-UE, Node B-UE cross-interferences).

~~When node synchronization is used, the following mechanism is applicable.~~

The architecture may have several solutions for Node Synchronization:

- Synchronization of nodes to an external reference via a standardized synchronization port;
- Synchronization of nodes B on the air interface, e.g. through nodes B cross measurements or assisted by UEs (TDD only)

~~Since it is desired to avoid dependence to an external system to provide Node Synchronisation, a specific solutions for UTRAN is needed. If the Network Synchronisation is very good, the drift between different nodes is slow, but will occur.~~

Some protocols over Iur and Iub are therefore specified to detect and correct a possible misalignment of the Node Synchronisation.

In order to achieve frame synchronization on UTRAN internal interfaces (Iub and Iur) it may be sufficient to know the timing relationships between nodes.

Knowledge of timing relationships between nodes ~~is may be~~ based on a measurement procedure, ~~Node Synchronization Procedure~~. This procedure is defined in the user plane protocols for Iub (DCH, DSCH, and FACH/PCH) and Iur (DCH). The procedure may also be carried out over a high priority transport bearer.

Measurements of node offsets can be made at start/restart as well as during normal operation to supervise the stability of the nodes.

Positioning / Localisation functions may also set requirements on ~~this~~ Node Synchronisation or timing relationships measurement procedure.

~~{TDD—Node Synchronisation and Frame synchronisation are used within neighbouring cells to minimise cross-interference (Node B-Node B, UE-UE, Node B-UE cross interferences)}-~~

## 9.4 Time-of-day

Time-of-day handling is used for O&M functions like radio network event time-stamping. A prerequisite for Time-of-day handling is Network synchronisation of UTRAN and CN Nodes.

### Counter names and definitions:

<b>BFN</b>	Node <b>B</b> Frame Number counter. This is the Node B common frame number counter, often hard-coupled with the 'good' node oscillator. BFN is optionally frequency-locked to a Network sync reference. <b>BFN is free-running, not phase-locked to any other counter.</b> <b>Range: 0 to 4095 frames, 12 bits.</b>
<b>RFN</b>	RNC Frame Number counter. This is the RNC node common frame number counter, often hard-coupled with the 'good' node oscillator. BFN is optionally frequency-locked to a Network sync reference. <b>RFN is free-running, not phase-locked to any other counter.</b> <b>Range: 0 to 4095 frames, 12 bits.</b>
<b>UFN</b>	UE Frame Number counter. This is the UE node common frame number counter, often hard-coupled with the 'good' oscillator. <b>UFN is frequency locked to UTRAN via air-interface SCH.</b> <b>Range: 0 to 4095 frames, 12 bits.</b>
<b>SFN</b>	Cell System Frame Number counter. This is the long counter in a Cell. SFN is sent on BCCH on Layer 1. SFN is used for paging groups and system information scheduling etc. <b>SFN = BFN adjusted with Tcell.</b> <b>Range: 0 to 4095 frames, 12 bits.</b>
<b>CFN</b>	Connection Frame Number (counter). CFN is used in Node B, RNC and UE for DCH and Common Transport Channels frame transport references. <b>Range: 0 to 255 frames, 8 bits.</b>
<b>HFN</b>	Hyper Frame Number (counter). This is the H number of most significant bits on top CFN to form a ciphering counter.
<b>CSN</b>	Ciphering Sequence Number (counter). This is the total counter in a node for Ciphering purposes. CSN = [HFN, CFN]. <b>Range: 0 to 2<sup>32</sup>-1 frames, 32 bits.</b>

## 9.6 Layer 2 Synchronisation

The L2 (or transport channel) synchronisation provides a L2 common frame numbering between UTRAN and UE (frame synchronisation between the L2 entities). This frame number is the Connection Frame Number (CFN), and it is

associated at L2 to every TBS and passed to L1: the same CFN is received on the peer side associated with the same TBS.

The CFN is not transmitted in the air interface for each TBS, but is mapped by L1 to the Cell\_SFN of the first radio frame used for the transmission of the TBS (the Cell\_SFN is broadcast at L1 in the BCH). The mapping is performed via the Frame\_offset parameter.

**In FDD:** In case of soft handover, the Frame\_offsets of the different radio links are selected in order to have a timed transmission of the diversity branches in the air interface.

A L1-MAC primitive is defined to allow the L1 to indicate to L2 the necessity to adjust the timing of the DL transmission, in order to control and minimise the transmission delay. The primitive is carried in the user plane by Frame Protocol procedures within the UTRAN. This transport channel synchronisation mechanism is valid for all the transport channels, in FDD and TDD modes.

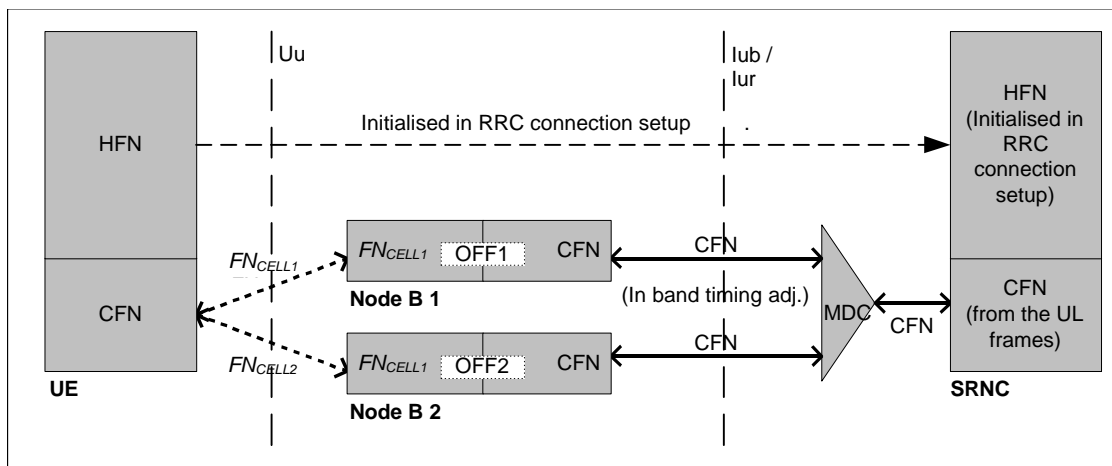

**Figure 9. Layer 2 synchronisation**

*Note:* The CFN used by the transport channel synchronisation mechanism may be extended to form a larger L2 counter (HFN, Hyper frame number), to be used for example for ciphering. The initialisation of this counter is done at RRC level and the parameter is not visible at lower layers.

The parameters related to L2 synchronisation are described in the following paragraphs.

## CFN

CFN is the frame counter used for the L2/transport channel synchronisation between UE and UTRAN. A CFN value is associated to each TBS and it is passed together with it through the MAC-L1 SAP. CFN provides a common frame reference (at L2) to be used for ciphering and synchronised transport channel reconfiguration, for example.

Since the CFN is mapped into one Cell\_SFN and defines a specific frame for the transmission on the air interface, some L1-MAC primitives are defined to minimise the buffering time for the transmission on the air interface (i.e. to ensure that the TBS does not arrive too much in advance respect to the transmission time), and, in general, to control the delays in the transport channel.

The duration of the CFN cycle shall be longer than the maximum allowed transport delay between MAC and L1 (in UTRAN side, between SRNC and Node B, because the L1 functions that handle the transport channel synchronisation are in the Node B). Furthermore the CFN shall be shorter, or at most equal to the Cell\_SFN. Currently the Cell\_SFN is 12 bits long, and the proposal is to adopt 8 bits (2.56 seconds) for the CFN.

The range of CFN is 0...255 (integer value).

*Note:* WG3 is still studying the possibility to extend the CFN for the PCH to 12 bits, for long sleepmode paging.

## 9.6.2 Frame\_offset

Frame\_offset is a radio link specific L1 parameter used to map the CFN, used in the transport channel, into the cell SFN transmitted between UE and UTRAN at L1.

At the L1/L2 interaction, the mapping is performed as:

$$\text{Cell\_SFN} = \text{CFN} - \text{Frame\_offset} \quad (\text{from L2 to L1}) \quad (1.1)$$

$$\text{CFN} = \text{Cell\_SFN} + \text{Frame\_offset} \quad (\text{from L1 to L2}) \quad (1.2)$$

The resolution of all three parameters is 1 frame. Frame\_offset and CFN have the same range (8 bits, 0...255) and only the 8 least significant bits of the Cell\_SFN are used. The operations above are modulo 256, i.e. 256 is added if the result is negative and subtracted if the result is above 255.

In the UTRAN, the Frame\_offset parameter is calculated by the SRNC and provided to the node-B.

## 9.6.3 Cell\_SFN

Each cell has a Cell System Frame Number. This Cell\_SFN is broadcasted on the BCH. The current WG3 assumption is that the Cell\_SFN has a length of 12 bits.

## 9.7 FDD Radio Interface synchronisation

As shown above, the transport channel synchronisation mechanism defines the radio frame in which the TBS transmission shall be started. From this reference point, another parameter **Chip Offset** is used in FDD to define the exact timing of the radio frame transmission. ~~Those parameters are the time slot for TDD and the Chip Offset for FDD.~~

~~The parameters related to L1 synchronisation are described in the following paragraphs.~~

### {FDD — Chip Offset}

The Chip\_offset is used as offset for the DL DPCH relative to the PCCPCH timing. The Chip\_offset parameter has a resolution of 1 chip and a range of 0 to 38399 (< 10ms).

The Chip\_offset parameter is calculated by the SRNC and provided to the node-B. The details concerning rounding the Chip\_offset value to Td are FFS.

### 9.7.2 {TDD — Time slot}

~~The time slot parameter indicates in which time slot within the frame the transmission shall take place.~~

## 9.7.3 Synchronisation parameters from/to the UE

In FDD in order to obtain L1 and L2 synchronisation with the UTRAN, the UE reports and receives several parameters. This is not necessary in TDD, since Frame synchronisation based on Node synchronisation is used.

*Note: Currently WG3 is assuming that the UE may report 2 separate parameters (Tm and OFF) when adding a RL. WG2 liaison "Response to LS on UE requirement to report OFF" (TSGR3#6(99)842) discussed in R3#6, indicated that WG2 has not yet taken a final decision if 1 or 2 separate parameters will be reported by the UE. If WG2 decides to only report 1 (combined) parameter, the description below will have to be change but no major consequences are foreseen.*

### 9.7.3.4 OFF

The reported OFF parameter has a resolution of 1 frame and a range of 0 to 255. OFF shall only be sent when the UTRAN has requested the UE to send this parameter. In the neighbouring cell list, the UTRAN indicates for each cell if the Frame\_offset is already known by the UTRAN or shall be measured and reported by the UE.



Five different cases are discerned related to the determination of the OFF value by the UE:

1. The UE changes from common channel state to dedicated channel state: 1 RL  
In this case OFF will be zero (is it even reported ?).
2. The UE changes from common channel state to dedicated channel state: several RL's  
OFF is in this case defined as being the difference between Cell\_SFN of the camping cell and the Cell\_SFN of the other candidate cells. Again the UE sets OFF to zero for the cell to which the UE sends an UL RRC message (cell #1). For cells #2 to n, the UE sets OFF to the difference between the Cell\_SFN of cell#2,n and the Cell\_SFN of cell#1.
3. The UE adds another RL in dedicated channel state (macro-diversity)  
OFF is in this case defined as being the time difference between the CFN and the Cell\_SFN of the cell in which the RL is to be added.
4. The UE is coming from another RAN and goes to dedicated channel state: 1 RL  
This case is identical to case 1)
5. The UE is coming from another RAN and goes to dedicated channel state: several RL's  
This case is identical to case 2), with one exception: OFF will not be zero for the cell to which the UE sends an UL RRC message (the measurement information will be received via the CN in this case) but for a reference cell selected by the UE. All other reported OFF values will be relative to the Cell\_SFN of this selected reference cell.

### 9.7.3.2 Tm

The reported Tm parameter has a resolution of 1 chip and a range of 0 to 38399. The Tm shall always be sent by the UE.

Again five cases are discerned are discerned related to the determination of the OFF value by the UE:

1. The UE changes from common channel state to dedicated channel state: 1 RL  
In this case the Tm will be zero (is it even reported ?).
2. The UE is changes from common channel state to dedicated channel state: several RL's  
Tm is in this case defined as being the time difference between the received PCCPCH path of the camping cell and the received PCCPCH paths of the other candidate cells. Again the UE sets Tm to zero for the cell to which the UE sends an UL RRC message (cell #1). For cells #2 to n, the UE sets Tm to the time difference of the PCCPCH reception timing of cell#2,n from the PCCPCH reception timing of cell#1.
3. The UE adds another RL in dedicated channel state (macro-diversity)  
Tm is in this case defined as being the time difference between " $T_{TX,UL} - T_o$ " and the earliest received PCCPCH path of the target cell.  $T_{TX,UL}$  is the time when the UE transmits an uplink DPCCCH frame, hence " $T_{TX,UL} - T_o$ " is the "optimum" arrival time for the first path of a received DPCH.
4. The UE is coming from another RAN and goes to dedicated channel state: 1 RL  
This case is identical to case 1)
5. The UE is coming from another RAN and goes to dedicated channel state: several RL's  
This case is identical to case 2), with one exception: Tm will not be zero for the cell to which the UE sends an UL RRC message (the measurement information will be received via the CN in this case) but for a reference cell selected by the UE. All other reported Tm values will be relative to the timing of the PCCPCH in this cell.

### 9.7.3.3 DOFF

It is assumed that the SRNC sends a DOFF parameter to the UE when the new RL will make the UE change its state (from common channel state or other when coming from another RAN) to the dedicated channel state.

The DOFF parameter has a resolution of 512 chips and a range of 0 to 599 (<80ms). The maximum value is chosen in accordance with the largest interleaving period supported on Uu.

The DOFF value sent to the UE is determined by the SRNC based on certain (load distributing) algorithms.

## 9.8 Calculations performed in the UTRAN (FDD only)

This chapter describes how an SRNC can calculate the Frame\_offset and Chip\_offset based on the parameters received from the UE and available in the UTRAN.

### UE in common channel state.

In common channel state (UE on RACH/FACH), the Frame\_offset is set to 0.

#### 9.8.2 UE changes state from common CH state to dedicated CH state: 1 RL

Based on the received parameters from the UE and the DOFF value generated in the SRNC, the SRNC calculates the Frame\_offset and the Chip\_offset:

$$\text{Frame\_offset} * 38400 + \text{Chip\_offset} = \text{DOFF} * 512 \quad (4.1)$$

#### 9.8.3 UE changes state from common CH state to dedicated CH state: several RL's

Based on the received parameters from the UE and the DOFF value generated in the SRNC, the SRNC calculates the Frame\_offset and the Chip\_offset. The Frame\_offset and the Chip\_offset are calculated from the following formula:

$$\text{Frame\_offset} * 38400 + \text{Chip\_offset} = \text{DOFF} * 512 + \text{OFF} * 38400 + T_m \quad (4.2)$$

*Note [1]: note that formula (2) is covering formula (1) since in case 1, OFF and T<sub>m</sub> are both equal to zero.*

#### 9.8.4 UE requests to add a new RL in dedicated CH state

Based on the received parameters from the UE, the SRNC calculates the Frame\_offset and the Chip\_offset with the following formula:

$$\text{Frame\_offset} * 38400 + \text{Chip\_offset} = \text{OFF} * 38400 + T_m \quad (4.3)$$

#### 9.8.5 Handover from other RAN to UMTS

Based on the definitions for OFF and T<sub>m</sub> provided in chapter 3.1. and 3.2., formula (4.1) can also be used when the UE enters the UTRAN from another CN and establishes 1 dedicated RL. The same is true for formula (4.2) when establishing 1 or more dedicated RL's.

## 9.9 Calculations performed in the UE (FDD only)

### First RL

Based on the received DOFF and the Cell\_SFN of the cell in which the UE is camping, the UE can calculate the CFN with the following formula:

$$\text{CFN} = ((\text{Cell\_SFN} * 38400 + \text{DOFF} * 512) \text{ div } 38400) \text{ mod } 256 \quad (5.1)$$

Note: in case the UE is coming from another RAN, the Cell\_SFN is not the Cell\_SFN from the camping cell but the Cell\_SFN from the reference cell.

In this case the OFF is set to 0.

#### 9.9.2 Additional RL's

As long as the UE has one or more RL's established, the CFN will be increased (mode 256) by 1 every frame. Normally no special corrections are needed when moving from one cell to the other.

However every time the UE enters a new cell the Frame\_offset, which might have to be reported in the OFF parameter, will have to be recalculated. The Frame\_offset for the new cell is computed using the following formula:

$$OFF[\text{new}] = (\text{CFN} - \text{Cell\_SFN}[\text{new}]) \bmod 256 \quad (5.2)$$

The difference OFF is calculated as the integer number of frames, with approximation to the lower integer number (*the exact definition of the difference is TBD*).

## 9.10 Timing adjustment in Iub/Iur interfaces

A receiving window is configured in Node B at Transport bearer Setup, Addition and Reconfiguration for DL frames (TOAWS and TOAWE). The purpose is to make it possible to supervise whether data frames are received in the window or not. When frames are received outside that window, a response is sent to RNC called Timing Adjustment Control frame. This response contains Time of Arrival information (TOA). See figure below.

The window could be defined to have a margin before LTOA (TOAWE > 0). This is to indicate to RNC that data frames are a bit late but they are still processed by Node B. In this case, data frames are received after TOAWE but before LTOA.

Offset values, used for sending data frames from RNC over Iub, could therefore be refined by using this window definition and supervising method.

DL Sync Control frames will always give TOA as response, even if the DL Sync Control frame is received within the window. The purpose of Sync Control frames is to measure when frames are received for a certain transport bearer.

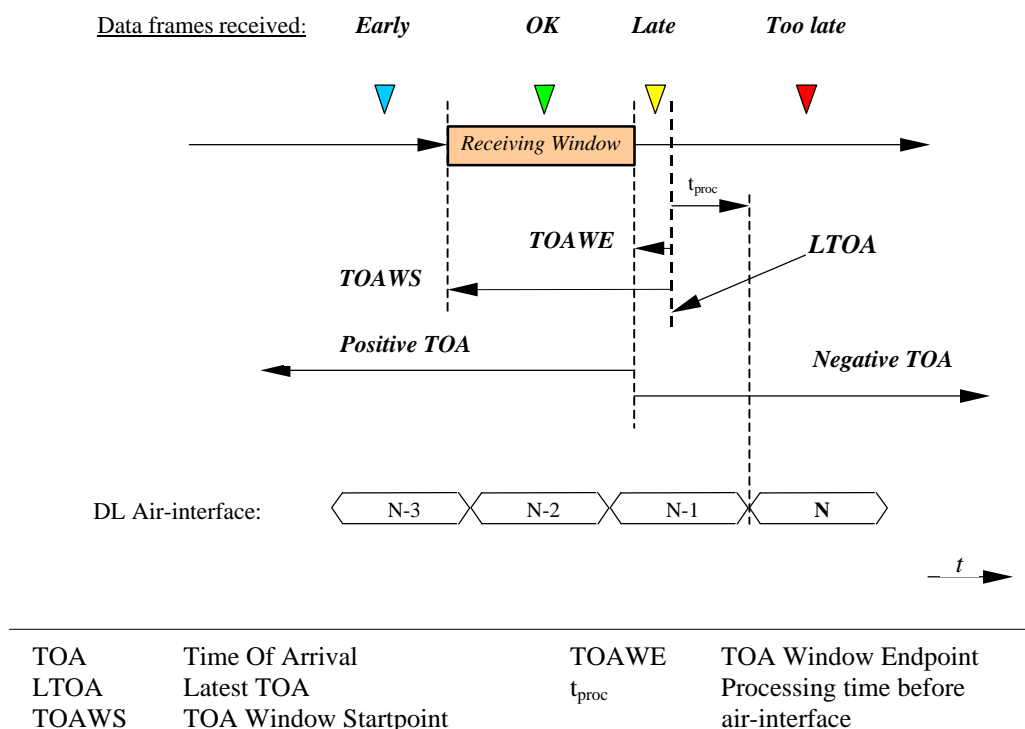

Figure 10. Illustration of TOAWS, TOAWE, LTOA and TOA

The window size and position can be chosen with respect to expected data frame delay variation and different macro-diversity leg delays.

The timing adjustment parameters are defined as follow:

- Time of Arrival Window Startpoint (TOAWS)**  
 TOAWS is the window startpoint. DL data frames are expected to be received after this window startpoint. TOAWS is defined with a positive value relative Time of Arrival Window Endpoint (TOAWE). A data frame arriving before TOAWS gives a Timing Adjustment Control frame response.

The TOAWS is a CFN length parameter.  
The resolution is 1 ms, the range is:  $\{0 \dots \text{CFN length}/2 - 1 \text{ ms}\}$

- **Time of Arrival Window Endpoint (TOAWE)**

TOAWE is the window endpoint. DL data frames are expected to be received before this window endpoint. TOAWE is defined with a positive value relative Latest Time of Arrival (LTOA). A data frame arriving after TOAWS gives a Timing Adjustment Control frame response.  
The TOAWE is a CFN length parameter.  
The resolution is 1 ms, the range is:  $\{0 \dots \text{CFN length} - 1 \text{ ms}\}$

- **Latest Time of Arrival (LTOA)**

LTOA is the latest time instant a Node B can receive a data frame and still be able to process it. Data frames received after LTOA can not be processed (discarded). LTOA is defined internally in Node B to be a processing time before the data frame is sent in air-interface. The processing time ( $T_{\text{proc}}$ ) could be vendor and service dependent.

LTOA is the reference for TOAWS and TOAWE.

- **Time of Arrival (TOA)**

TOA is the time difference between the TOAWE and when a data frame is received. A positive TOA means that data frames are received before TOAWE, a negative TOA means that data frames are received after TOAWE. Data frames that are received after TOAWE but before LTOA ( $\text{TOA} + \text{TOAWE} \geq 0$ ) are processed by Node B. When RNC measures data frame reception times to determine window position or to supervise data frame reception times, TOA could be added with TOAWE to make the measurements window position independent.

TOA has a resolution of 125  $\mu\text{s}$ .

TOA is positive when data frames are received before TOAWE.

The range is:  $\{0 \dots +\text{CFN length}/2 - 125 \mu\text{s}\}$ .

TOA is negative when data frames are received after TOAWE.

The range is:  $\{-125 \mu\text{s} \dots -\text{CFN length}/2\}$ .

## Synchronisation of L1 configuration changes

When a synchronised L1 configuration change shall be made, the SRNC commands the related node B's to prepare for the change. When preparations are completed and SRNC informed, serving RNC decides appropriate change time. SRNC tells the UE for the change by a suitable RRC message. The node B's are informed the CFN by NBAP Channel reconfiguration messages (~~name not yet agreed in SMG2-ARC~~) and/or RNSAP Radio Link Reconfiguration messages.

At indicated switch time UE and node B's change the L1 configuration.

## ~~[TDD — Frame Synchronisation]~~ Radio Interface Synchronisation

In the UTRA TDD mode, the cells within the UTRAN are synchronized with respect to Radio Frames and possibly to Multiframes (this second option is FFS). ~~This~~ The synchronization is achieved via a combination of absolute timing references such as GPS and/or GNSS, and simple adjustments commanded by the RNC's which are made by cells reading the synchronization channel of neighboring cells.

For time alignment of the uplink radio signals from the UE to the UTRAN, timing advance can be applied whenever necessary. Timing advance is based on uplink burst timing measurements performed by the Node B L1, and on Timing Advance commands sent downlink to the UE. The details are FFS.

### ~~9.12.1~~ Frame Synchronisation

This kind of synchronisation is necessary to ensure that the uplink/downlink switching points be positioned at the same time instant at least in adjacent cells (see Figure 11.).

This requirement is necessary to avoid that a receiving UE can be saturated by a transmitting UE in a neighbouring cell.

In addition it automatically ensures that the slots of different cells are synchronised, i.e. they do not overlap at the UE.

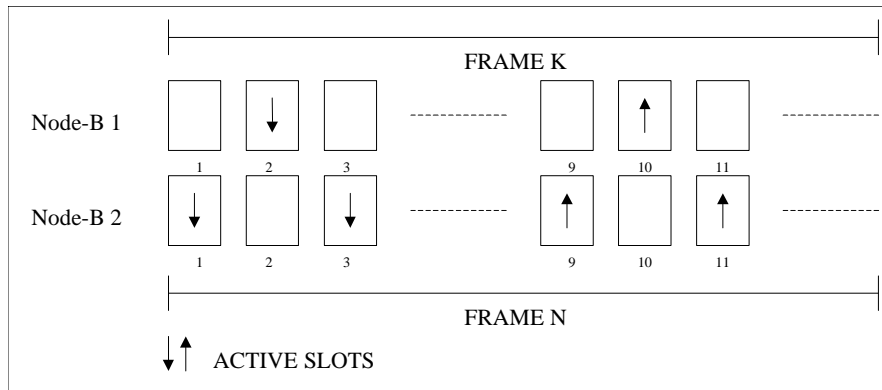

**Figure 11. Frame synchronisation**

Optionnal Input ~~and Output~~-synchronisation ports can be used to obtain this synchronisation- (see Annex A).

## Multi Frame Synchronisation

This kind of synchronisation may be required to keep more efficient and faster all procedures involving a switch from one Node-B to another, such as searching for new Base Stations, locking to new Base Stations or handover.

This Multi Frame Synchronisation is however FFS.

Note that a prerequisite for Multi Frame Synchronisation is that frames are synchronised.

For Multi Frame Synchronisation it is required that the frame numbers in neighbouring cells are time aligned, i. e. in Figure 11. this would mean  $N=K$ .

Also this synchronisation may be achieved via the optionnal Input synchronisation port (see Annex A)

## Frame Synchronisation over the air

This solution allow the synchronization of nodes B on the air interface through nodes B cross measurements of their synchronisation channel.

*[the following text has been taken from R99-905, accepted during WG3 #6]*

The RNC will occasionally tell the Node b cells to perform a simple cell search for a defined neighbor cell. It derives the time offset of the received signal with respect to its own reference and sends a response to the RNC containing the measured Time offset (units: chips; signed number; could be negative).

In this concept, the RNC has all relevant information stored, including sync channel toffset of the primary sync code, downlink scrambling code for the synchronization channel, etc., and passes the information to the node B for this procedure.

For pairs of cells; e.g. Base Station A and Base Station B, the RNC compares two corresponding time delays. Assuming that the measurements have been obtained at nominally the same time,

TAB = Time delay from A as seen by B

TBA= Time delay from B as seen by A

Then, defining

deltaT = the time error to be estimated,

R = the distance between the Base Stations

c = speed of light

We obtain

TAB = deltaT +R/c

TBA = -deltaT +R/c

and

deltaT = (TAB-TBA)/2

Note that R is not needed for the actual calculation. However, noting that TAB+TBA=2\*R/c, this could be used to optimize processing.

## Effect of non-simultaneous measurements

Consider the effect induced because measurements are not necessarily taken at the same time. If the two base stations under consideration have no drift rate relative to one another, then there is no error introduced by non-simultaneous measurements.

If there is a significant drift, then the RNC must use some form of tracking algorithms, for instance a simple one could be periodic re-synchronization using the basic principle outlined above.

## Connectivity issues

It is possible that there is not complete connectivity; i.e. islands of cells, not connected via the air to one another. It is proposed that each group of cells within an island (could be entire network if full connectivity exists), would have at least one cell with an external accurate timing reference.

## 9.8 Time Alignment handling

Time Alignment handling is the functionality to adapt to 10 ms framing (or to unit length e.g. 20 ms) i.e. to send and receive frames 'just-in-time' and thus minimizing the delay. TA is an issue between Vocoders and the Diversity handover unit (DHO) in RNC. TA could also be used for circuit switched services like data.

## 10 UTRAN O&M Requirements

### 10.1 O&M of Node B

The O&M of Node B is separated in two parts : the O&M linked to the actual implementation of Node B, denoted as Implementation Specific O&M, and the O&M which impacts on the traffic carrying resources in Node B controlled from the RNC, denoted *logical O&M*. The RNS architecture with the O&M interfaces is shown in Figure 12.

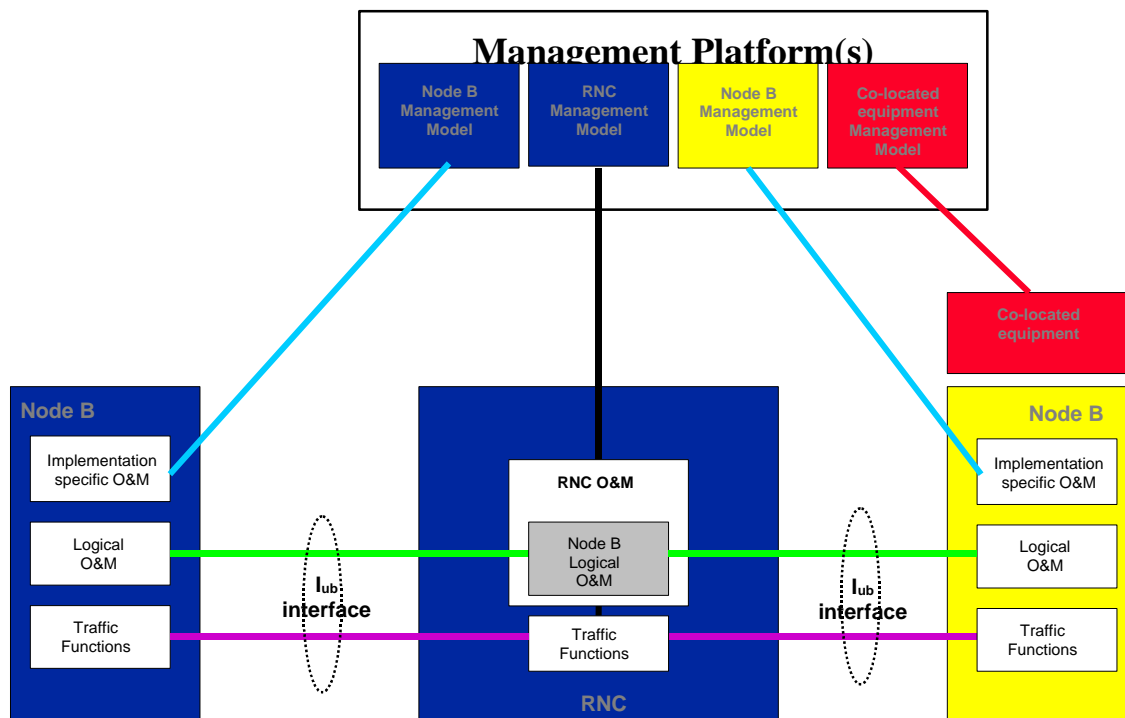

Figure 12. RNS architecture with O&M interfaces

Note: The concept of an interface from the RNC to the management system is shown for clarity only. It's definition is outside the scope of 3GPP-TSG-RAN-WG3.

Note: The presentation of the O&M functions within the management system is shown for clarity only. Their actual implementation is outside the scope of 3GPP-TSG-RAN-WG3.

Note: Implementation Specific O&M can be routed directly to the management system through a specific interface or it can be routed via the RNC, thus sharing the same physical transport as the Iub interface.

Note: The standardisation of the Implementation Specific O&M is outside the scope of 3GPP-TSG-RAN-WG3. The 3GPP-TSG-RAN-WG3 should only address the bearer for the Implementation Specific O&M.

*Note: The categorisation of Node B O&M functions into either Logical or Implementation Specific O&M is FFS.*

*Note: The concept of an interface to support signalling between co-located equipment and the management system is FFS.*

## 40.1.1 Implementation Specific O&M

The Implementation Specific O&M functions are heavily dependent on the implementation of Node B, both for its hardware components and for the management of the software components. It needs therefore to be implementation dependent, and be performed between Node B and the management system.

- This means that the standardisation in 3GPP-TSG-RAN-WG3 should only address the *transport* of O&M signalling between the management system and Node B. This transport can be performed by a transport mechanism, possibly IP. The transport can be potentially across the RNC, but not necessarily. Between RNC and Node B, dedicated PVCs or SVCs could be used.

## 40.1.2 Logical O&M

Logical O&M is the signalling associated with the control of logical resources (channels, cells,...) owned by the RNC but physically implemented in the Node B. The RNC controls these logical resources. A number of O&M procedures physically implemented in Node B impact on the logical resources and therefore require an information exchange between RNC and Node B. All messages needed to support this information exchange are classified as Logical O&M forming an integral part of NBAP.



## 4.4 UTRAN Interfaces

### 4.4.1 General Protocol Model for UTRAN Interfaces

#### 4.4.1.1 General

The general protocol model for UTRAN Interfaces is depicted in Figure 13., and described in detail in the following sub-sections. The structure is based on the principle that the layers and planes are logically independent of each other, and if needed, protocol layers, or the whole protocol stack in a plane may be changed in the future by decisions in the standardisation.

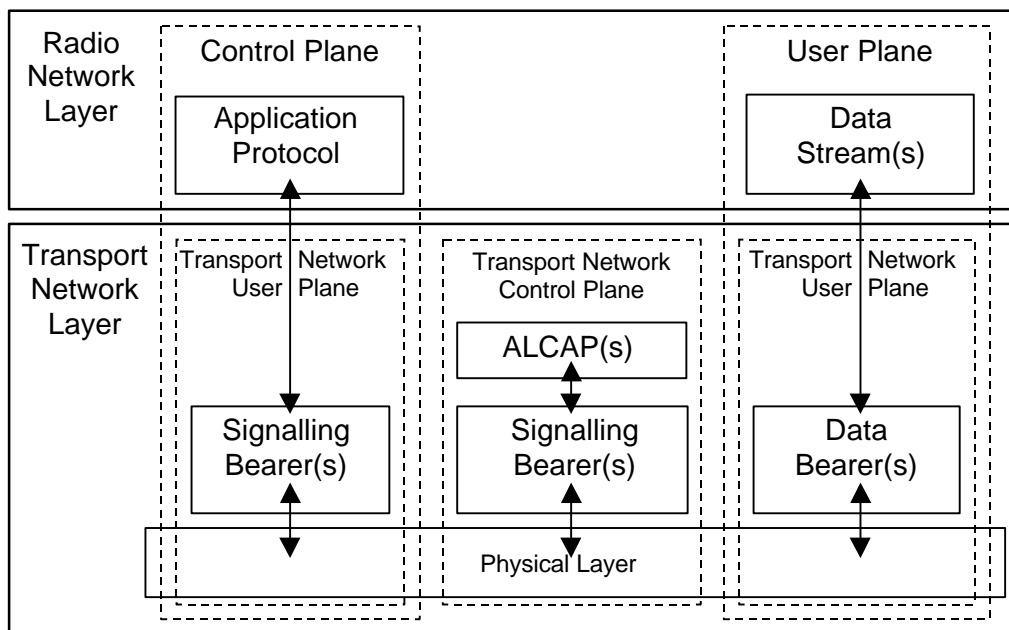

Figure 13. General Protocol Model for UTRAN Interfaces

#### 4.4.1.2 Horizontal Layers

The Protocol Structure consists of two main layers, Radio Network Layer, and Transport Network Layer. All UTRAN related issues are visible only in the Radio Network Layer, and the Transport Network Layer represents standard transport technology that is selected to be used for UTRAN, but without any UTRAN specific requirements.

#### 4.4.1.3 Vertical Planes

##### 4.4.1.3.1 Control Plane

The Control Plane Includes the Application Protocol, i.e. RANAP, RNSAP or NBAP, and the Signalling Bearer for transporting the Application Protocol messages.

Among other things, the Application Protocol is used for setting up bearers for (i.e. Radio Access Bearer or Radio Link) in the Radio Network Layer. In the three plane structure the bearer parameters in the Application Protocol are not directly tied to the User Plane technology, but are rather general bearer parameters.

The Signalling Bearer for the Application Protocol may or may not be of the same type as the Signalling Protocol for the ALCAP. The Signalling Bearer is always set up by O&M actions.

### 41.1.3.2 User Plane

The User Plane Includes the Data Stream(s) and the Data Bearer(s) for the Data Stream(s). The Data Stream(s) is/are characterised by one or more frame protocols specified for that interface.

### 41.1.3.3 Transport Network Control Plane

The Transport Network Control Plane does not include any Radio Network Layer information, and is completely in the Transport Layer. It includes the ALCAP protocol(s) that is/are needed to set up the transport bearers (Data Bearer) for the User Plane. It also includes the appropriate Signalling Bearer(s) needed for the ALCAP protocol(s).

The Transport Network Control Plane is a plane that acts between the Control Plane and the User Plane. The introduction of Transport Network Control Plane makes it possible for the Application Protocol in the Radio Network Control Plane to be completely independent of the technology selected for Data Bearer in the User Plane.

When Transport Network Control Plane is used, the transport bearers for the Data Bearer in the User Plane are set up in the following fashion. First there is a signalling transaction by the Application Protocol in the Control Plane, which triggers the set up of the Data Bearer by the ALCAP protocol that is specific for the User Plane technology.

The independence of Control Plane and User Plane assumes that ALCAP signalling transaction takes place. It should be noted that ALCAP might not be used for all types Data Bearers. If there is no ALCAP signalling transaction, the Transport Network Control Plane is not needed at all. This is the case when pre-configured Data Bearers are used.

It should also be noted that the ALCAP protocol(s) in the Transport Network Control Plane is/are not used for setting up the Signalling Bearer for the Application Protocol or for the ALCAP during real time operation.

The Signalling Bearer for the ALCAP may or may not be of the same type as the Signalling Bearer for the Application Protocol. The Signalling Bearer for ALCAP is always set up by O&M actions.

### 41.1.3.4 Transport Network User Plane

The Data Bearer(s) in the User Plane, and the Signalling Bearer(s) for Application Protocol, belong also to Transport Network User Plane. As described in the previous section, the Data Bearers in Transport Network User Plane are directly controlled by Transport Network Control Plane during real time operation, but the control actions required for setting up the Signalling Bearer(s) for Application Protocol are considered O&M actions.

## 41.2 Protocol Model (Informative)

The following section is a informative section which aim is to provide an overall picture of how the MAC layer is distributed over Uu, Iub and Iur for the RACH, FACH and DCH.

### 41.2.1 RACH Transport Channel

Figure 14 shows the protocol stack model for the RACH transport channel when the Controlling and Serving RNC are co-incident.

For the RACH transport channel, Dedicated MAC (MAC-d) uses the services of Common MAC (MAC-c).

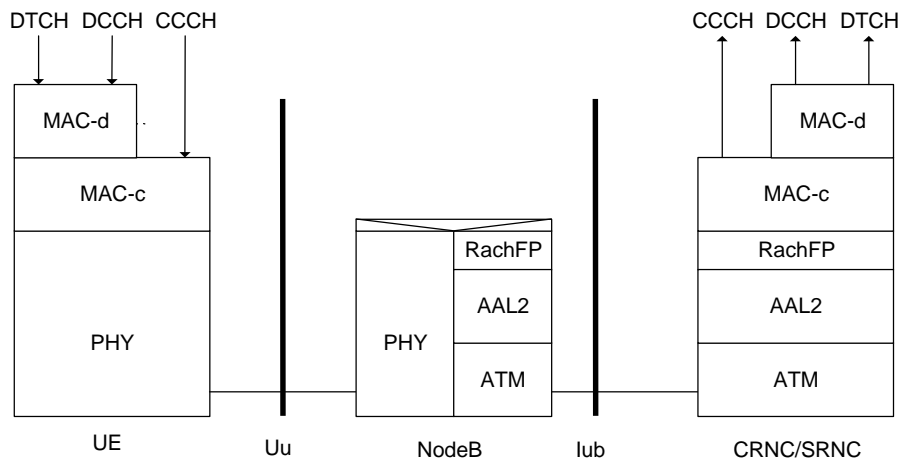

**Figure 14. RACH: Coincident Controlling and Serving RNC**

The Common MAC (MAC-c) entity in the UE transfers MAC-c PDU to the peer MAC-c entity in the RNC using the services of the Physical Layer.

An Interworking Function (IWF) in the NodeB interworks the RACH frame received by the PHY entity into the RACH Frame Protocol (RACH FP) entity.

The RACH Frame Protocol entity adds header information to form a RACH FP PDU which is transported to the RNC over an AAL2 (or AAL5) connection.

At the RNC, the RACH FP entity delivers the MAC-c PDU to the MAC-c entity.

Figure 15. shows the protocol model for the RACH transport channel with separate Controlling and Serving RNC. In this case, Iur RACH Frame Protocol (DchFP) is used to interwork the Common MAC (MAC-c) at the Controlling RNC with the Dedicated MAC (MAC-d) at the Serving RNC (The exact Iur RACH Frame Protocol is FFS)

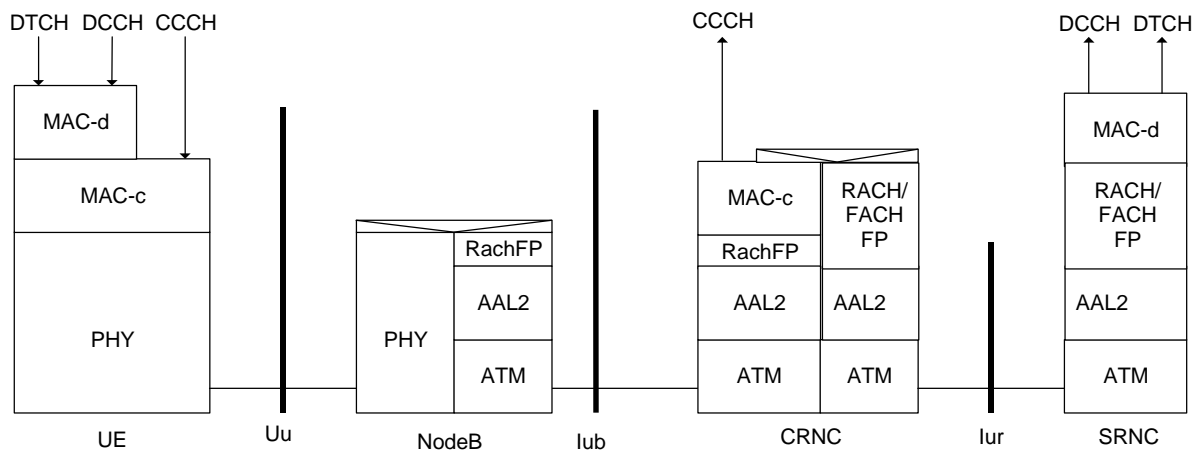

**Figure 15. RACH: Separate Controlling and Serving RNC**

### 41.2.2 FACH Transport Channel

Figure 16. shows the protocol model for the FACH transport channel when the Controlling and Serving RNC are coincident.

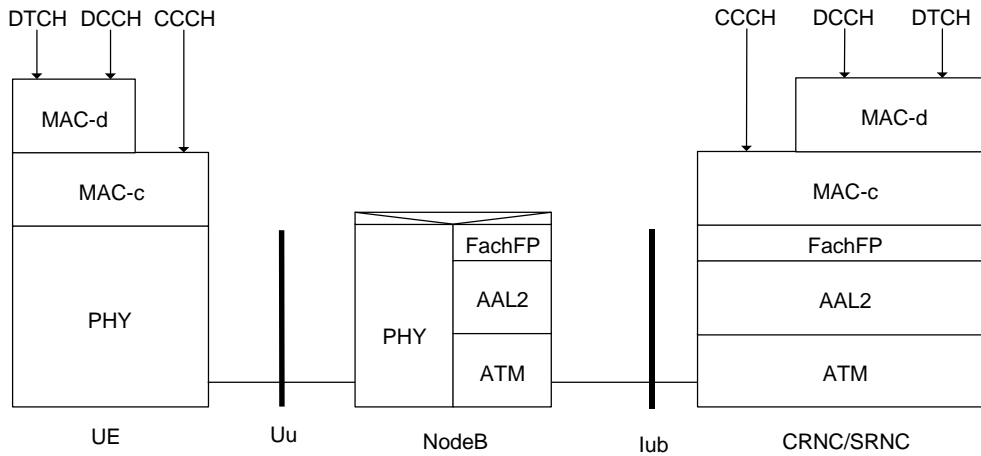

**Figure 16. FACH Co-incident Controlling and Serving RNC**

The Common MAC (MAC-c) entity in the RNC transfers MAC-c PDU to the peer MAC-c entity in the UE using the services of the FACH Frame Protocol (FACH FP) entity.

The FACH Frame Protocol entity adds header information to form a FACH FP PDU which is transported to the NodeB over an AAL2 (or AAL5) connection.

An Interworking Function (IWF) in the NodeB interworks the FACH frame received by FACH Frame Protocol (FACH FP) entity into the PHY entity.

FACH scheduling is performed by MAC-c in the CRNC.

Figure 17. shows the protocol model for the FACH transport channel with separate Controlling and Serving RNC. In this case, Iur FACH Frame Protocol is used to interwork the Common MAC (MAC-c) at the Controlling RNC with the Dedicated MAC (MAC-d) at the Serving RNC (The exact Iur **RACH-FACH** Frame Protocol is FFS)

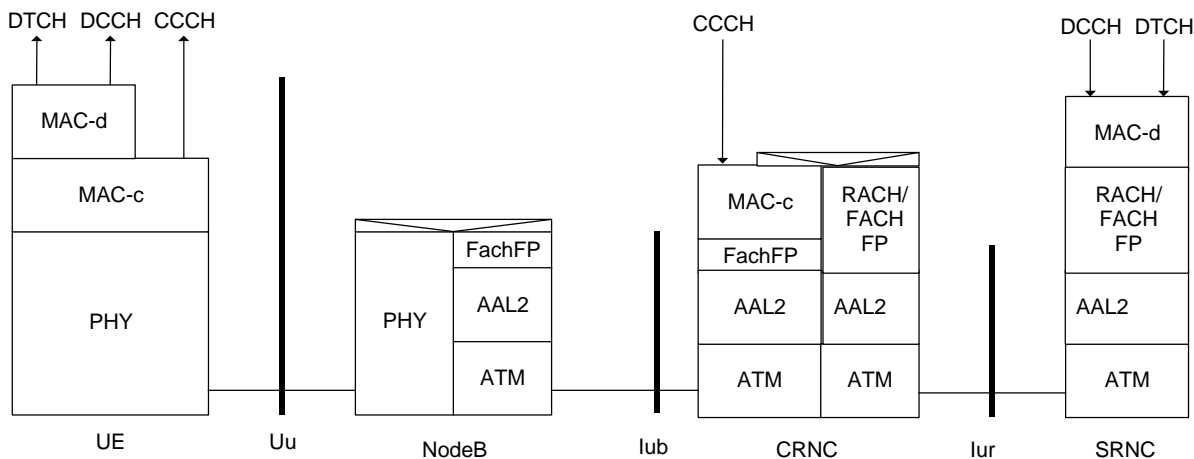

**Figure 17. FACH: Separate Controlling and Serving RNC**

### 41.2.3 DCH Transport Channel

Figure 18. shows the protocol model for the DCH transport channel when the Controlling and Serving RNC are co-incident.

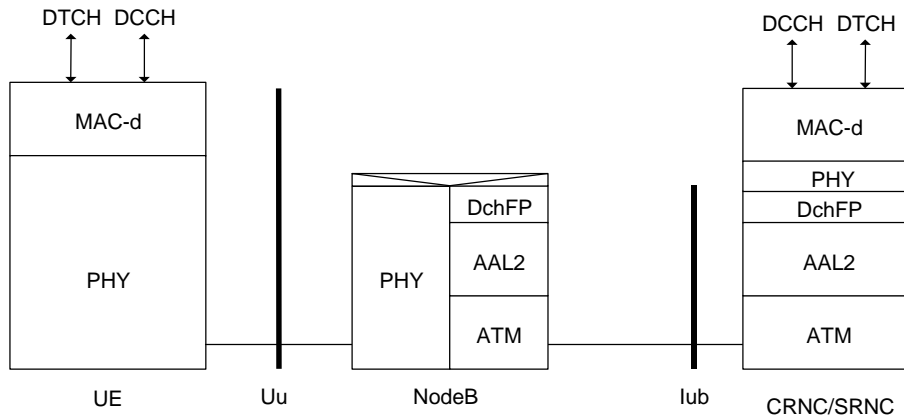

**Figure 18. DCH: Co-incident Controlling and Serving RNC**

The DCH transport channel introduces the concept of distributed PHY layer.

An Interworking Function (IWF) in the NodeB interworks between the DCH Frame Protocol (DCH FP) entity and the PHY entity.

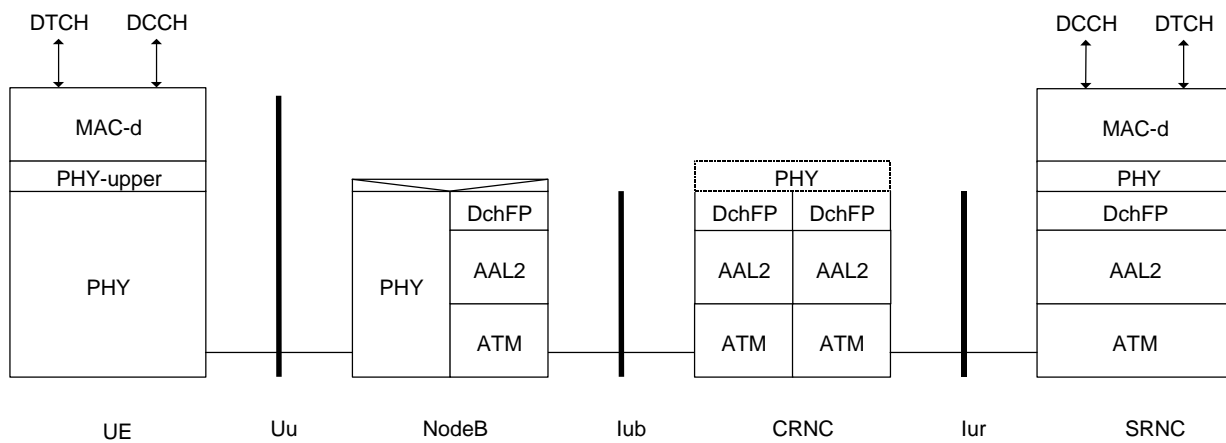
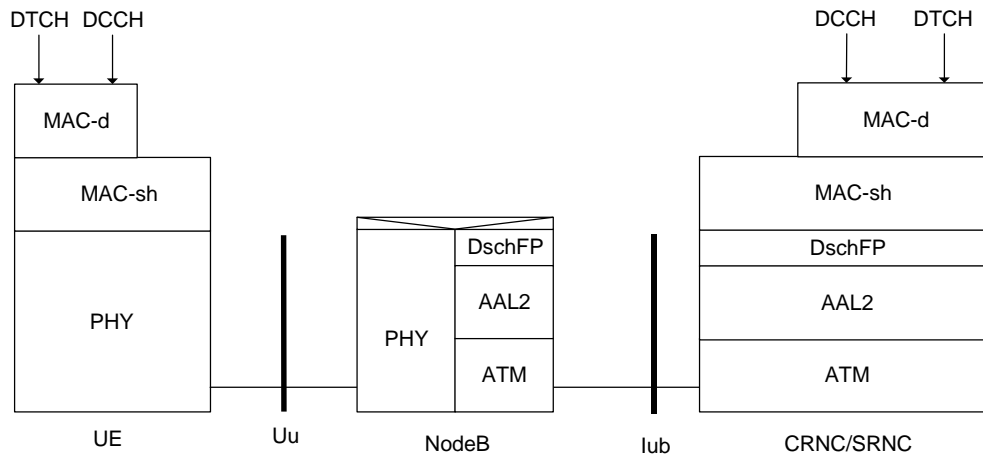

**Figure 19. DCH: Separate Controlling and Serving RNC**

Figure 19. shows the protocol model for the DCH transport channel with separate Controlling and Serving RNC. In this case, the Iub DCH FP is terminated in the CRNC and interworked with the Iur DCH FP through a PHY function. This function performs optional soft handover or can be a null function.

## DSCH Transport Channel

Figure 20. shows the protocol model for the DSCH transport channel when the Controlling and Serving RNC are co-incident.

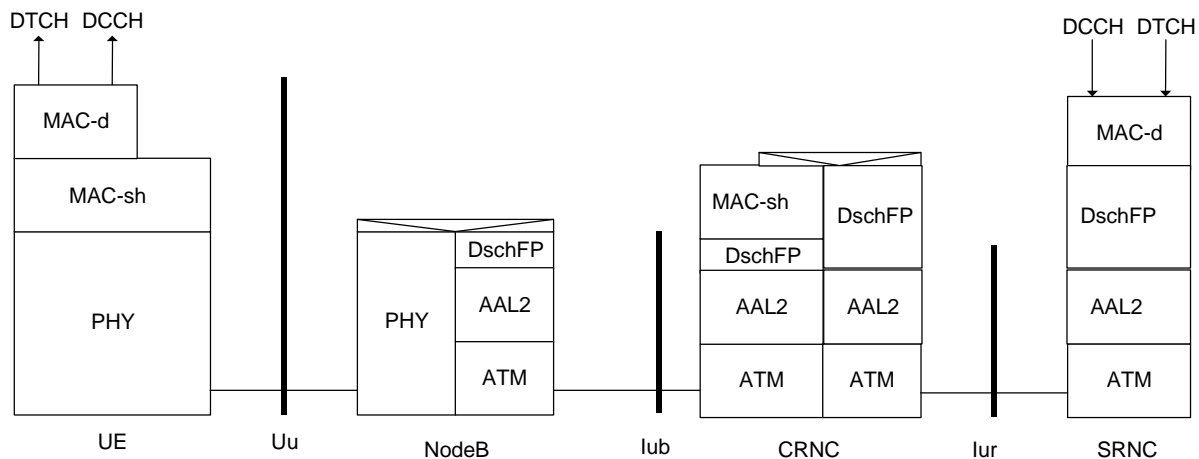

**Figure 20. DSCH Co-incident Controlling and Serving RNC**

The Shared MAC (MAC-sh) entity in the RNC transfers MAC-sh PDU to the peer MAC-sh entity in the UE using the services of the DSCH Frame Protocol (DSCH FP) entity. The DSCH FP entity adds header information to form a DSCH FP PDU which is transported to the Node B over an AAL2 (or AAL5) connection.

An Interworking Function (IWF) in the Node B interworks the DSCH frame received by DSCH FP entity into the PHY entity. DSCH scheduling is performed by MAC-sh in the CRNC.

Figure 21. shows the protocol model for the DSCH transport channel with separate Controlling and Serving RNC. In this case, Iur DSCH Frame Protocol is used to interwork the MAC-sh at the Controlling RNC with the MAC-d at the Serving RNC.



**Figure 21. DSCH: Separate Controlling and Serving RNC**

### 11.2.5 USCH Transport Channel

< Editor's comment: This USCH chapter is the same as for DSCH, except

- DSCH has been replaced by USCH.
- Changed or added words-

>

Figure 1 Figure xxx shows the protocol model for the USCH transport channel when the Controlling and Serving RNC are co-incident.

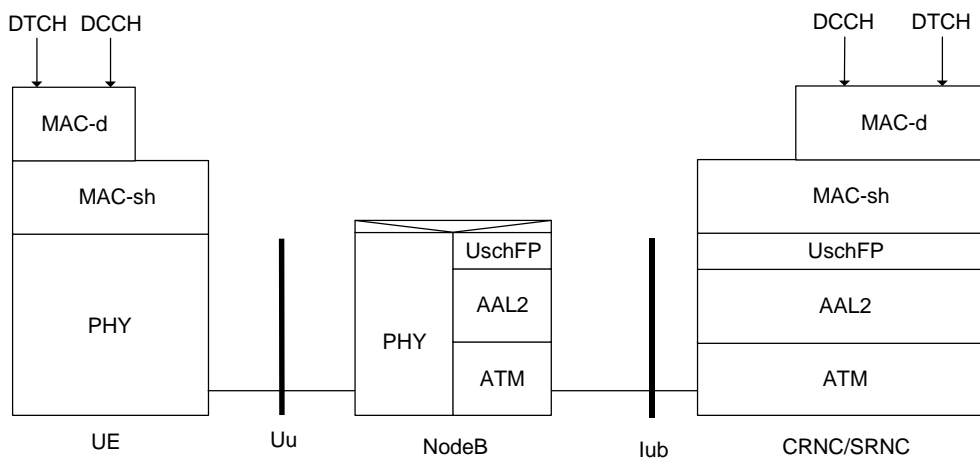
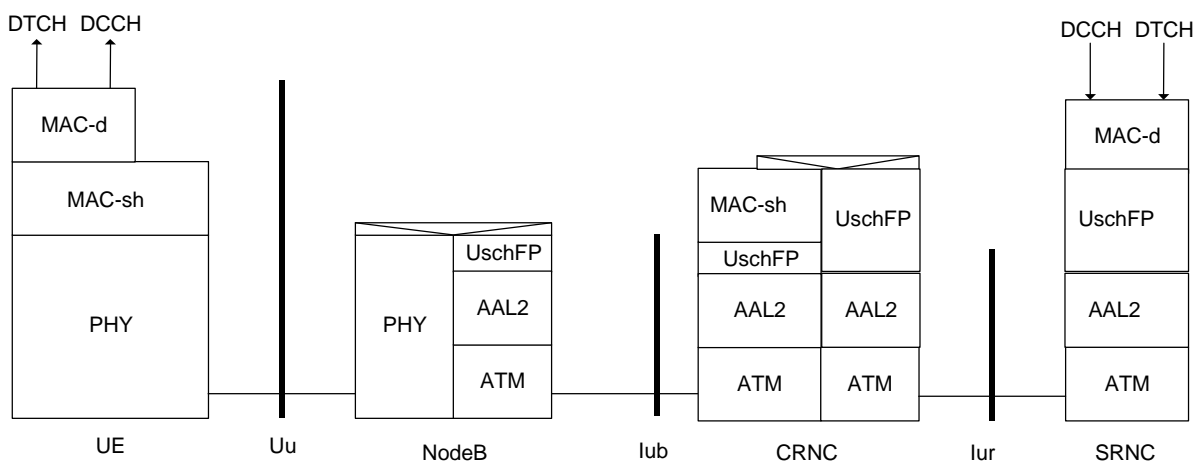

**Figure 1. USCH Co-incident Controlling and Serving RNC**

The Shared MAC (MAC-sh) entity in the RNC receives MAC-sh PDU from the peer MAC-sh entity in the UE using the services of the Interworking Function in the NodeB, and the USCH Frame Protocol (USCH FP) entity. The USCH FP entity in the NodeB adds header information to form a USCH FP PDU which is transported to the RNC over an AAL2 (or AAL5) connection.

An Interworking Function (IWF) in the Node B interworks the received USCH PHY entity into an USCH frame to be transmitted by the USCH FP entity over the Iub interface. USCH scheduling is performed by MAC-sh in UE and by C-RRR in the CRNC.

Figure 21. shows the protocol model for the USCH transport channel with separate Controlling and Serving RNC. In this case, Iur USCH Frame Protocol is used to interwork the MAC-sh at the Controlling RNC with the MAC-d at the Serving RNC.



**Figure 22. USCH: Separate Controlling and Serving RNC**

---

## 42 UTRAN Performance Requirements

### 42.1 UTRAN delay requirements

The maximum transmission delay of a diversity branch and the maximum processing delay introduced by single UTRAN network elements shall be defined.



## Annex A: TDD Synchronisation port

This section defines the Node B input and an output synchronisation ports.

The input synchronisation port (SYNC IN) allows the node B to be synchronised to an external reference (e.g. GPS), while the output synchronisation port (SYNC OUT) allows the node B to synchronise directly another node B.

The node B starts the synchronisation to the external reference when a valid input synchronisation signal is detected at the input synchronisation port.

If a valid synchronisation signal is detected, the node B regenerates that signal at its output synchronisation port. The propagation delay between the input and output synchronisation ports shall not exceed [FFS] ns.

The electrical characteristics of the synchronisation ports shall conform to RS422 [1] (output synchronisation port: section 4.1; input synchronisation port: section 4.1).

*Note: The detailed signal layout of such ports as described below is FFS.*

The synchronisation signal (illustrated in Figure 23.) is a 100 Hz signal having positive pulses of width between 5  $\mu$ s and 1 ms, except for frame 0 (every 72nd pulse), which has a pulse width between 2 ms and 5 ms. This signal establishes the 10 ms frame interval and the 720 ms multiframe interval.

The start of a frame is defined by the falling edge of the pulse.

The start of the multiframe is defined by the falling edge of the pulse corresponding to frame 0 (i.e. of width between 2 ms and 5 ms).

The synchronisation signal at the input port shall have a frequency accuracy better than the one of the node B.

The relative phase difference of the synchronisation signals at the input port of two neighbouring nodes B shall not exceed [FFS]  $\mu$ s.

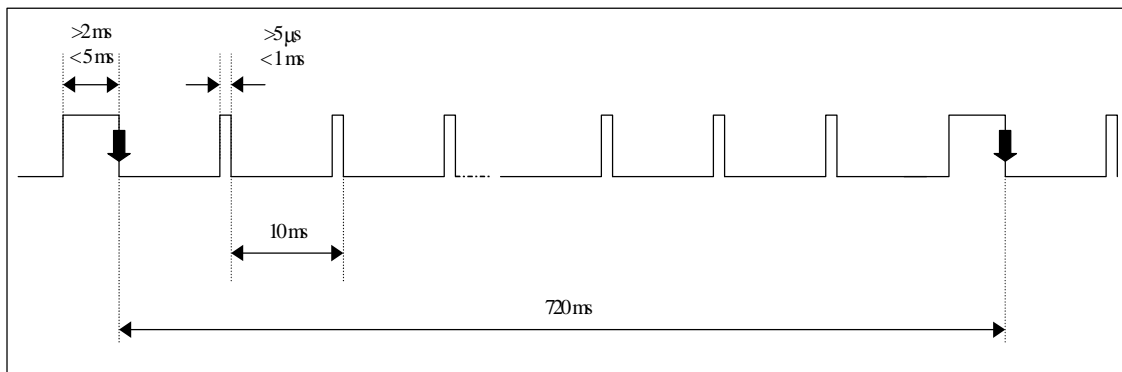

Figure 23. Synchronisation signal

## Annex BA Document Stability Assessment Table

Section	Content missing	Incomplete	Restructuring needed	Checking needed	Editorial work required	Finalisation needed	Almost stable	Stable
<del>01</del>								√
<del>02</del>					√			
<del>03</del>				√				

04					√			
05								√
06		√					√	
07		√	√					
08				√				
09						√		
010								√
011								√
012	√							

## Annex C List of open issues

The open issues identified by the editor are the following:

1. List of functions needs some update and review
2. Complete Synchronisation overview
3. Time of day handling
4. Performance requirements
5. Support for positioning

## History

Document history		
0.0.1	February 1999	Document Structure Proposal
0.0.2	February 1999	<ul style="list-style-type: none"> <li>• Use of 3GPP Template</li> <li>• Introduction of content from the Merged UTRAN Architecture Description</li> </ul>
0.0.3	February 1999	Annexe A : Protocol Stacks for Distributed MAC moved to section "0 Protocol Model".

0.0.4	March 1999	<p>Approval of revisions of version 0.0.3</p> <p>Revised according to the decision of 3GPP TSG RAN WG3 Meeting #2</p> <ul style="list-style-type: none"> <li>• Title of the document changed to UTRAN Overall Description</li> <li>• Modification of section " Allocation of Downlink Channelisation Codes " according to the result of Study Item ARC/2</li> <li>• Update of section " 0 UTRAN O&amp;M Requirements " from Tdoc R3-99155.</li> <li>• Creation of section " 0 UTRAN Identifiers" and introduction of DCH-ID in the logical model of Node B according to Tdoc R3-99174.</li> <li>• Alignment of section " 0 Usage of RNTI " with the liaison from TSG RAN WG2.</li> <li>• Update of sections " User Plane Transport bearers"according to Tdoc R3-99190.</li> <li>• Enancement of section " Node B logical Model over Iub " from Tdoc R3-99160.</li> <li>• Enancement of section " DRNS logical Model over Iur " from Tdoc R3-99159.</li> </ul>
0.0.5	April 1999	<p>Revision of 0.0.4 according to remarks sent on mail reflector :</p> <ul style="list-style-type: none"> <li>• Addition of reference to UMTS 23.10</li> <li>• Fixed references to documents in sections 0 and 0.</li> <li>• Cleaning of Section 0,.</li> <li>• Alignment of section " Radio Application Control Plane Transport bearers " S23.30.</li> <li>• Revoval of QoS mapping from section User Plane Transport bearers "</li> <li>• Creation of section " 0 General Protocol Model for UTRAN Interfaces " to capture the agreed UTRAN interfaces protocol model from Tdoc R3-99223.</li> </ul>
0.1.0	April 1999	Mail Approval of version 0.0.5 by TSG RAN WG3.
1.0.0	April 1999	Noted by TSG RAN and Changed reference from S3.01 to TS 25.401

1.0.1	April 1999	<p>Editorial proposal :</p> <ul style="list-style-type: none"> <li>• Deletion of section 11.2. and 11.2.1</li> <li>• Section 11.2.2 : Moved to document TS 25.410 except for SRNS Relocation section which is moved to section 7.</li> <li>• Section 11.3.1 : Moved to document TS 25.420 except for some functional splitting which is moved to section 7.</li> <li>• Section 11.3.2 : Moved to document TS 25.430 except for some functional splitting which is moved to section 7.</li> <li>• Section 12 is moved to the relevant documents TS 25.4xx : <ul style="list-style-type: none"> <li>• § 12.1.1 ⇒ TS 25.412</li> <li>• § 12.1.2 ⇒ TS 25.414</li> <li>• § 12.1.3 ⇒ TS 25.414</li> <li>• § 12.2.1 ⇒ TS 25.422</li> <li>• § 12.2.1.1 ⇒ TS 25.420</li> <li>• § 12.2.2 ⇒ TS 25.424</li> <li>• § 12.2.3 ⇒ TS 25.526</li> <li>• § 12.3.1 ⇒ TS 25.432</li> <li>• § 12.3.2 ⇒ TS 25.434</li> <li>• § 12.3.3 ⇒ TS 25.434</li> </ul> </li> </ul>
1.0.2	May 1999	<p>Approval of revision of version 1.0.1</p> <p>Revised according to the decision of 3GPP TSG RAN WG3 Meeting #3</p> <ul style="list-style-type: none"> <li>• Section 3.1 use RNC in the Iur definition instead of RNS according to Tdoc R3-99262.</li> <li>• Creation of Section "0 Transport Addresses" from Tdoc R3-99275.</li> <li>• Admission control in CRNC in section "0 Admission Control" according to Tdoc R3-99388.</li> <li>• Update of Definitions according to Tdoc R3-99321 and UMTS Vocabulary document.</li> <li>• Editorial cleaning of section "10 UTRAN O&amp;M Requirements" from Tdoc R3-99322.</li> <li>• Editorial cleaning of section "0 RACH Transport Channel": removal of MAC-lc</li> </ul>
1.0.3	May 1999	<ul style="list-style-type: none"> <li>• Addition of Document Stability Assessment Table</li> <li>• Addition of Abbreviations</li> </ul>
1.1.0	June 1999	Approval of 1.0.3 by 3GPP TSG RAN WG3 and version raised to 1.1.0
1.1.1	June 1999	<p>Revised according to decisions of 3GPP TSG RAN WG3 Meeting #4</p> <ul style="list-style-type: none"> <li>• Cleaning of section "0 Synchronisation" from Tdoc R3-99470</li> <li>• Add illustration of BID usage in section "0 Binding identifier" from Tdoc R3-99479</li> </ul>

1.2.0	July 1999	<p>Addition of RAN subflows definition from Tdoc R3-99460</p> <p>Removal of figure 10 "Radio interface downlink synchronisation"</p> <p>Rewording of the introductory sentence of Figure 6.: "Figure 6. illustrates how application instances of the Radio Network Control Plane and instances of the Transport Network Plane are linked together through the Binding Identifier in the set-up phase:"</p> <p>Approval of 1.1.1 with the above modification by 3GPP TSG RAN WG3 and version raised to 1.2.0</p>
1.2.1	July 1999	<p>Revised according to decisions of 3GPP TSG RAN WG3 Meeting #5</p> <ul style="list-style-type: none"> <li>• Removal of some Editor's notes</li> <li>• Addition of the definition of the following identifier according to Tdoc R3-99772: PLMN Id, CN Domain Id, RNC Id and Cell Id in section "0 UTRAN Identifiers"</li> <li>• Modification of the definition of RNTI according to Tdoc R3-99662 in section "0 UE Identifiers" and alignment of section "0 Usage of RNTI"</li> <li>• Restructuring of section "0 Synchronisation" according to Tdocs R3-99777, R3-99698 and R3-766. Editorial modifications to align text with the changes.</li> <li>• Creation of section "0 TDD " according to Tdoc R3-99604</li> <li>• Modification of section "0 Logical O&amp;M" from R3-99783.</li> </ul>
1.3.0	September 1999	<p>Introduction of Coordinated DCHs definition from Tdoc R3-99450.</p> <p>Cleaning of the history table</p> <p>Approval of 1.2.1 with the above modification by 3GPP TSG RAN WG3 and version raised to 1.3.0.</p>
1.3.1	September 1999	<p>Revised according to decisions of 3GPP TSG RAN WG3 Meeting #6</p> <ul style="list-style-type: none"> <li>• Creation of section "0 DSCH Transport Channel" according to Tdoc R3-99850 and update of Figure 15., Figure 17. &amp; Figure 21. to include the RACH/FACH FP and the AAL-2 transport bearer.</li> <li>• Modification of section "0 Synchronisation" to reflect the agreed outcome of the sync ad hoc. Editorial work from Tdocs R3-99A36, R3-99A24, R3-99A24, R3-99875 and R3-99878</li> <li>• Filling of section "0 TDD " and creation of "Annex A: TDD Synchronisation port" from Tdoc R3-99959.</li> <li>• Introduction of section "0 TDD " according to Tdoc R3-99905.</li> <li>• Addition of LAC for CN PS domain Id in section "0 CN Domain Identifier" according to Tdoc R3-99A27.</li> <li>• Filling in section "0 Node Synchronisation" as an editor's proposal from Tdoc R3-99A45.</li> <li>• Addition of "Annex C List of open issues"</li> </ul>

Rapporteur for 3GPP RAN TS 25.401 is:

Jean Marie Calmel  
Nortel Wireless Networks

Tel. : +33 1 39 44 52 82

Fax : +33 1 39 44 50 12

Email : [calmel@nortelnetworks.com](mailto:calmel@nortelnetworks.com)

This document is written in Microsoft Word version 97