

TSG-RAN Working Group 2 (Radio layer 2 and Radio layer 3)
Sophia-Antipolis 16th 20th August 1999

TSGR2#6(99)717

Agenda Item: 12.3 [LCS]

Source: Editor

3G TR 25.923 V1.1.0 (1999-08)

Technical Specification
**3rd Generation Partnership Project (3GPP);
Technical Specification Group (TSG) RAN;
Working Group 2 (WG2);**

Report on Location Services (LCS)



The present document has been developed within the 3rd Generation Partnership Project (3GPPTM) and may be further elaborated for the purposes of 3GPP. The present document has not been subject to any approval process by the 3GPP Organisational Partners and shall not be implemented. This Specification is provided for future development work within 3GPP only. The Organisational Partners accept no liability for any use of this Specification. Specifications and reports for implementation of the 3GPPTM system should be obtained via the 3GPP Organisational Partners' Publications Offices.

Reference

<Workitem> (<Shortfilename>.PDF)

Keywords

Location Service,
Digital cellular telecommunications system,
Universal Mobile Telecommunication System LCS,
(UMTS), UTRA, UTRAN, IMT-2000

3GPP

Postal address

Office address

Internet

secretariat@3gpp.org
Individual copies of this deliverable
can be downloaded from
<http://www.3gpp.org>

Copyright Notification

No part may be reproduced except as authorized by written permission.
The copyright and the foregoing restriction extend to reproduction in all media.

© 1999
All rights reserved.

Contents

1	Foreword.....	5
2	Scope	6
3	Introduction.....	7
3.1	Location feature	7
3.2	General Arrangement.....	8
4	Main concepts.....	10
4.1	Observed Time Difference of Arrival (OTDOA).....	10
4.1.1	Idle Slot Forward Link (ISFL-TDOA).....	11
4.2	Round Trip Time (RTT)	11
4.3	Angle of Arrival (AOA).....	12
4.4	Observed Time of Arrival (OTOA)	12
4.5	Base Station Synchronisation.....	12
4.6	General Navigation Systems	13
4.7	Location Services Server (LCS Server)	13
4.8	Positioning information sources.....	14
5	Technical service requirements.....	16
5.1	Requirements framework	16
5.2	Functional Requirements.....	18
5.2.1	Quality of Service (QoS).....	18
5.2.1.1	Comments on accuracy requirements	18
5.2.1.2	Horizontal Accuracy	19
5.2.1.3	Vertical Accuracy.....	19
5.2.1.4	Response Time	20
5.2.1.5	Priority	20
5.2.2	Timestamp.....	20
5.2.3	Security	21
5.2.3.1	Authorisation.....	21
5.2.3.2	Privacy	21
5.2.4	Feature Support.....	22
5.2.4.1	Roaming UE.....	22
5.2.4.2	Roaming UE Client	22
5.2.4.3	Support for all Handsets.....	22
5.2.4.4	Support for Roaming Subscribers	23
5.2.4.5	Support for Unregistered Handsets	23
5.2.5	Periodic Location Reporting	23
6	UTRAN LCS Architecture.....	24
6.1	Interfaces.....	25
6.1.1	Iu Interface.....	25
6.1.2	Iur Interface.....	26
6.1.3	Iub Interface.....	26
6.1.4	Uu Interface	26
6.2	LCS Operations.....	27
6.2.1	LCS Operation Basis.....	27
6.3	High-Level Functions.....	28
6.3.1	LCS Application Functions	28
6.3.2	Subscription and Authorisation Functions	29
6.3.3	Coordination, Measurement and Calculation Functions.....	29
6.3.4	UE Functions	30
6.4	Logical Architecture	30
6.4.1	LCS Application	32
6.4.1.1	Location Client Function (LCF).....	32
6.4.2	UTRAN LCS Entities	32
6.4.2.1	Location System Control Function (LSCF).....	33
6.4.2.2	Location System Billing Function (LSBF).....	33
6.4.2.3	Location System Operations Function (LSOF)	34

6.4.2.4	Location System Information Function (LSIF)	34
6.4.3	Positioning Handling Entities.....	34
6.4.3.1	Positioning Radio Coordination Function (PRCF).....	34
6.4.3.2	Positioning Calculation Function (PCF)	34
6.4.3.3	Positioning Signal Measurement Function (PSMF)	35
6.4.3.4	Positioning Radio Resource Management (PRRM).....	35
6.4.4	Location Measurement Unit (LMU)	35
6.5	Allocation of functional entities to network entities.....	36
7	Technical operations	38
7.1	Operation of OTDOA technique	38
7.1.1	Accuracy	39
7.1.2	Relative Time Difference (RTD)	40
7.1.3	Time-of-Day (ToD).....	41
7.1.4	Observability (“Hearability”).....	41
7.2	Round Trip Time	42
7.3	Angle of Arrival.....	43
7.4	Observed Time of Arrival.....	43
7.5	General Navigation system assisted	43
7.6	Combined techniques	43
8	Measurements	44
8.1	UE (mobile station).....	44
8.1.1	Support for OTDOA measurement	44
8.1.2	Support for RTT measurement.....	45
8.2	Node-B (base station)	45
8.2.1	RTT Measurement	45
8.2.2	Frequency offset.....	45
8.2.3	Survey location	46
8.3	Relative Time Difference (RTD)	46
8.4	Error budgets.....	46
9	Signalling requirements	47
9.1	UTRAN - UE.....	47
9.1.1	OTDOA	47
9.1.2	Navigation System Assisted.....	49
9.1.2.1	Network Assisted, UE Based (GPS)	49
9.1.2.2	Network Based, UE Assisted (GPS)	50
9.1.3	Other methods	50
9.2	UTRAN – Node-B/LMU	51
9.2.1	Round Trip Time (RTT)	51
10	History	53

1 Foreword

This Technical Specification has been produced by the 3GPP.

The contents of the present document are subject to continuing work within the TSG and may change following formal TSG approval. Should the TSG modify the contents of this TS, it will be re-released by the TSG with an identifying change of release date and an increase in version number as follows:

Version 3.y.z

where:

- x the first digit:
 - 1 presented to TSG for information;
 - 2 presented to TSG for approval;
 - 3 Indicates TSG approved document under change control.
- y the second digit is incremented for all changes of substance, i.e. technical enhancements, corrections, updates, etc.
- z the third digit is incremented when editorial only changes have been incorporated in the specification.

2 Scope

This 3GPP Telecommunication Report contains an outline of the Location Services feature and its operation within the UTRAN. This includes an outline of general operating principles, the system requirements, the functional entities within the UTRAN and the general signalling.

3 Introduction

[Editorial note : this report has been prepared by TSG RAN WG2 to form a nucleus for further discussion and development of the Location Service for UTRAN. Material has been adapted from a number of UMTS and GSM sources and from working group discussions. While the material is generally believed to be suitable, many items are still FFS at this stage.

The UMTS and GSM texts on location services were still under development at the time this version of the report was prepared. Thus, this document may not fully reflect the latest versions. This material has been used here as a means to begin the outline of the LCS for UTRAN.]

This report discusses the LoCation Services (LCS) feature within UTRAN¹. This feature provides the mechanisms to support mobile location services for operators, subscribers and third party service providers.

This report covers general aspects of LCS including, the functional model, positioning methods, measurements and message flows.

Location Services may be considered as a network provided enabling technology consisting of standardised service capabilities, which enable the provision of location applications. The application(s) may be service provider specific. The description of the numerous and varied possible location applications which are enabled by this technology are outside the scope of this report. However, clarifying examples of how the functionality being described may be used to provide specific location services may be included in various sections of this report.

3.1 Location feature

By making use of the UTRAN radio signals, and other sources, the capability to determine the (geographic) location of the user equipment (UE) mobile station shall be provided. The location information may be requested by and reported to a client (application) associated with the UE or by a client within or attached to the UTRAN. The location information may also be utilised internally by UTRAN, for example, for position assisted handover or to support other features such as home location billing. The position information shall be reported in standard formats, such as those for cell based or geographical co-ordinates, *[editorial note: there is a standard format for these reports already in GSM. This may need some extensions for UTRAN.]* together with the time-of-day and the estimated errors (uncertainty) of the location of the UE.

The uncertainty of the location measurement shall be network design (implementation) dependent at the choice of the network operator. The uncertainty may vary between networks as well as from one area within a network to another. The uncertainty may be hundreds of metres in some areas and only a few metres in others. It is the intent for the system design that an uncertainty of less than ± 50 metres be achievable in a typical terrestrial radio environment. In

¹ UMTS Radio Access Network

the event that the location measurement is also a UE assisted process, the uncertainty may also depend on the capabilities of the UE. In some jurisdictions, there is a regulatory requirement for location service accuracy that is part of an emergency service. In the United States, for example, the current requirement is for accuracy within 125 metres for 67% of the emergency calls.

The techniques available for use at a location may also affect the uncertainty dependent on the state of the UE (idle or communications state). Several design options of the UTRAN system (e.g. size of cell, adaptive antenna technique, path loss estimation, timing accuracy, base station surveys) shall allow the network operator to choose a suitable and cost effective location service feature for their market.

There are many different possible uses for the location information. The positioning feature may be used internally by the UTRAN network (or attached networks), by value-added network services, by the UE itself or through the network, and by “third party” services. The positioning feature may also be used by an emergency service (which may be mandated or “value-added”), but the position service is not exclusively for emergencies. It shall be possible for the majority of the UE (active or idle) within a network to use the feature without compromising the radio transmission or signalling capabilities of the UTRAN.

The UTRAN is a new radio system design without a pre-existing deployment of UE operating according to the air interface. This freedom from legacy equipment enables the positioning service feature design to make use of appropriate techniques to provide the most accurate results. The technique must also be a cost-effective total solution, must allow evolution to meet evolving service requirements and be able to take advantage of advances in technology over the lifetime of UTRAN deployments.

3.2 General Arrangement

The following figure shows the general arrangement of the Location Service feature. Communication among the entities involved makes use of the messaging and signalling capabilities of the UTRAN.

As part of their service or operation, the LCS Clients may request the location information of user equipment UE (or group of UE) or mobile stations. There may be more than one LCS client. These may be associated with the network, operated as part of the network, operated as part of a UE application or accessed by the UE through its access to an application (e.g. through the Internet). The operating procedures of the UTRAN may make use of the location of the UE for such things as location-assisted handover, fleet management or home location billing.

The clients make their requests to an LCS Server. There may be more than one LCS Server associated with the UTRAN or associated networks. The server authenticates the client and then coordinates the resources of the network, including the Node-Bs (base stations) the UE and calculation functions, to estimate the location of the UE and return the result to the client. As part of this process the server may make use of information from auxiliary sources of information and other systems (outside UTRAN) such as navigation services. As part of the location information returned to the client, the server provides an estimate of the accuracy of the estimate and the time-of-day the measurement was made.

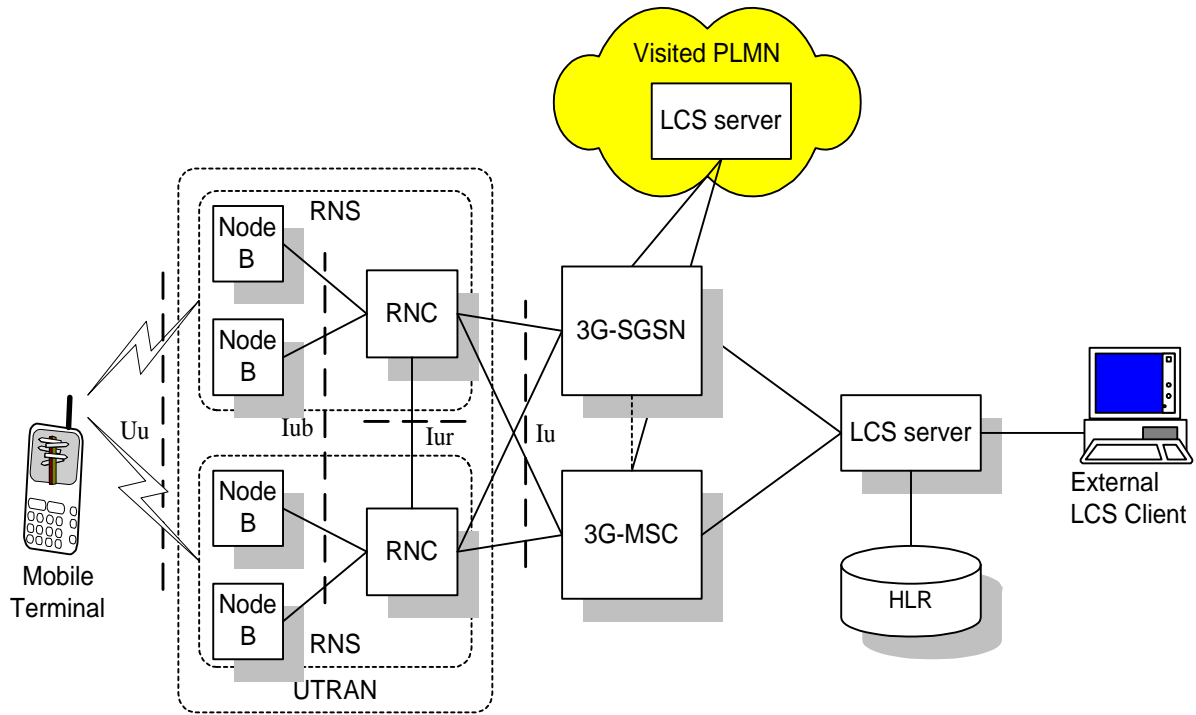

FIGURE General Arrangement of LCS

4 Main concepts

The LCS feature utilizes one or more positioning mechanisms in order to determine the location of user equipment (UE) or Mobile Stations. Locating the position of a UE involves two main steps:

- signal measurements and
- position estimate computation based on the measurements.

A number of positioning mechanisms are proposed for LCS :

- Observed Time Difference of Arrival (OTDOA),
- Round Trip Time (RTT),
- Angle of arrival (AOA),
- Observed Time of Arrival (OTOA) and
- General navigation system assisted.

The OTDOA mechanism is described in this report. The Round Trip Time (RTT) mechanism may be used to assist the OTDOA, or other processes. These mechanisms may be used in combination and also may operate in combination with techniques used in other radio modes (e.g. GSM). The other mechanisms are not discussed in detail in this version of this report and their outline is FFS.

4.1 Observed Time Difference of Arrival (OTDOA)

The OTDOA method is based on measuring the difference in time of arrival of downlink signals received at the UE. These measurements, together with information concerning the surveyed geographic location of the base stations and the relative time difference (RTD) of the actual transmissions of the downlink signals enables an estimate of the position of the UE to be calculated. Each OTDOA measurement for a pair of base stations describes a hyperbola² along which the UE may be located. The intersection of these hyperbolas for several measurements determines the UE's position. The accuracy of the location estimates made with this technique depends on the precision of the timing measurements, the relative position of the base stations involved³, and is also subject to the effects of multipath radio propagation.

There are two OTDOA modes: UE assisted OTDOA and UE based OTDOA. The two modes differ in where the actual location calculation is carried out. In *UE assisted* mode, the UE measures the difference in time of arrival of several cells and signals the measurement results to the network, where a network element (the Positioning Calculation Function (PCF)) carries out the location calculation. In *UE based* mode, the UE makes the measurements and also carries out the location calculation, and thus requires additional information (such as the location of the measured base stations) that is required for the location calculation.

² This is really a figure in three dimensions, a hyperboloid. For convenience here, this will be simplified to the hyperbola representing the intersection of this surface with the surface of the earth. For location service in three dimensions the hyperboloid must be considered.

³ The geometry of the base station positions may affect the accuracy of the location estimate. The best results are when the base stations equally surround the UE. If they do not, there is a reduction in accuracy, which is sometimes termed the Geometric Dilution of Position (GDP).

The signalling requirements for the two OTDOA modes are described in sub-section 10.

4.1.1 Idle Slot Forward Link (ISFL-TDOA)

For realizing location based services the support of physical layer is a prerequisite, so that the measurements required for the terminal location calculation can be carried out. In UTRAN there are several factors that must be taken into account while considering the physical layer procedures related to location services:

hearability: the basic feature of a CDMA radio system is that a terminal near its serving base station cannot hear other base stations on the same frequency. In order to calculate terminal location the terminal should be able to receive at least three base stations. To facilitate this some special means are required.

asynchronous network causes significant uncertainty to the time-difference-of-arrival (TDOA) measurements. To compensate for the effects of this, the relative time difference (the asynchronicity) between base station transmissions must be measured, and used for correcting TDOA measurement.

capacity loss: signalling related to location calculation may take capacity from other services. This capacity loss should be minimized.

Based on the results of the work done in ARIB SWG2/ST9 (Location Services) a solution for the above mentioned hearability problem is the IS-FL (Idle Slot⁴ Forward Link) method. In this method each base station ceases its transmission for short periods of time (idle slot). During an idle slot of a base station, terminals within the cell can measure other base stations and the hearability problem is reduced. Also, during idle slots the real time difference measurements can be carried out. Because IS-FL method is based on forward link (downlink) the location service can be provided efficiently to a large number of terminals simultaneously.

What is still required is detailed specifications how IS-FL is carried out. This specification work should include, for example, what physical channels are used for the TDOA measurements, how the idle slots are placed, and how this is signalled to terminals. This technique and the signalling required for its support, is FFS.

4.2 Round Trip Time (RTT)

The RTT method is based on the round trip time parameter for uplink transmissions. For a UE with an active call, the RTT value is known by the serving base station. To obtain RTT values when the UE is in idle mode a special call, not noticed by the subscriber (no ringing tone), may be set up. The cell-ID of the serving cell or sector and the RTT is determined. The RTT

⁴ Editorial Note – the use of the term Slot here may be confused with other slots within the radio system. Another choice of word may be advisable here.

measurement describes a circle (or arc within a sector) along which the UE may be located. This circle (or arc) may be combined with other techniques to resolve position ambiguity or to improve accuracy of other techniques. The accuracy of the position estimates made with this technique depends on the precision of the timing measurements, delays in the UE and is also subject to the effects of multipath radio propagation. The RTT may be used to assist all positioning mechanisms and as a fall-back procedure. If the UE is operating in the soft handover mode, the RTT will generally be that of the primary serving base station, although timing may also be available from other participating base stations.

The use of the round trip time technique in FDD is FFS. RTT may be more useful in UTRA than in GSM, because RTT from different base station is available when macrodiversity is used.

This technique and the signalling required for its support, is FFS.

4.3 Angle of Arrival (AOA)

The location service technique may make use of the angle of arrival of the radio signals to estimate the UE location. This technique may, for example, make use of the sector of the base station used for receiving or transmitting to establish the location region and to assist to resolve ambiguity in other techniques. Some other techniques may make use of narrow beam antennas to resolve the direction between the UE and the base station to a very small angle. These techniques and the signalling required for their support, are FFS.

4.4 Observed Time of Arrival (OTOA)

The location service technique may make use of measurements of the time of arrival of signals. A UE, for example, which has available a suitable reference time, may measure the time of arrival of signals from the base stations and others sources. Some of these may include reference signals from satellites. The time-of-arrival may be used to estimate the distance from the source and hence derive a location estimate.

The OTOA technique may also be used to measure signals transmitted by the UE. Base stations which are able to receive signals from the UE, and which share a suitable reference time, may each measure the time of arrival of signals from the UE. These times-of-arrival may be used to estimate the distance to the UE and hence derive a location estimate.

These techniques and the signalling required for their support, are FFS.

4.5 Base Station Synchronisation

It is preferable to develop positioning methods that do not require the base station network to be synchronised. The needed level of synchronisation accuracy for LCS is not by any means straightforward to achieve. The necessary information of Relative Time Differences (RTD) between base stations can be measured by dedicated units (LMU, Location Management Unit) and distributed in the network (e.g. as broadcast information). Also, RTD measurements benefit from the Idle Slot Forward Link (ISFL) technique.

In the TDD operating mode the base stations will typically be synchronised and this may be of assistance to the LCS technique.

4.6 General Navigation Systems

Some UE will be equipped with auxiliary equipment and software to enable them to make estimates of their location based on radio signals and techniques outside the UTRAN environment. For example, some UE may be equipped to receive general navigation signals⁵. Many of these make use of satellite transmissions. These UE may be able to report their location independent of the use of the UTRAN signals.

The UTRAN radio system may also transmit auxiliary information (e.g. in its broadcast signalling channel). This information may assist the UE in its use of the navigation systems. Broadcast information could include, for example, the local, currently observable satellites, local corrections, or information to speed satellite signal acquisition. As the signalling channel for many navigation systems is quite slow, the use of the UTRAN radio signalling channels may considerably speed the use of the navigation system. The operator may choose to specially encode (e.g. encrypt) this broadcast information to make the information only available on a subscription basis.

Some UTRAN radio systems may also transmit signals that are designed to mimic the navigation signals. The UE, equipped with a suitable receiver, may supplement the available satellite signals with the terrestrial signal(s) and thereby derive a location estimate more rapidly or more accurately than may be possible using the navigation system alone.

Methods making use of the Global Positioning System (GPS) have been standardised for GSM. In order to facilitate efficient terminal implementation, and seamless location service operation between GSM and UTRAN, the support for GPS based methods must be compatible. The signalling requirements for the GPS based methods are described in sub-section 10.

4.7 Location Services Server (LCS Server)

The LCS general concept includes LCS servers, located in the UTRAN network, in an associated network or in the UE. The server manages the interaction of the LCS client process which requests the position information and the various components of the UTRAN that make the measurements and perform the location calculations based on the measurements.

There may be multiple LCS servers within the UTRAN or in associated networks. The LCS Client may choose the server most appropriate for its needs. A subscription may be necessary to access some servers.

⁵ Two of the currently operating systems are the Global Positioning System (GPS) operated by the Defense Department of the United States, and the GLONASS system operated by the Russian Federation. A Pan-European system (Galileo) is in the planning stage.

Generally there will be three classes of service, which may (or may not) be aligned with separate classes of server. There is the Commercial LCS, the Internal LCS and the Emergency LCS.

The **Commercial LCS** will typically be associated with an application that provides a value added service through knowledge of the UE location to the subscriber of the service. This may be, for example, a directory of restaurants in the local area of the UE together with directions for reaching them from the current UE location.

The **Internal LCS** will typically be developed to make use of the location information of the UE for UTRAN internal operations. This may include, for example, location assisted handover and traffic and coverage measurement.

The **Emergency LCS** will typically be part of a service provided to assist subscribers who place emergency calls. In this service, the location of the UE caller is provided to the emergency service provider to assist them in their response. This service may be mandatory in some jurisdictions. In the United States, for example, this service is mandated for all mobile voice subscribers.

The LCS servers and the signalling required for their support, are FFS.

4.8 Positioning information sources

The location service design should not be limited to a single technical technique or source of information. As operating conditions vary both within and between networks, the LCS design should be able to make use of as many measurements and techniques as are available and are appropriate for the needs of (and the cost of) the service being provided.

The location process shall include the option to include all of the available UTRAN signals, including those from other networks with coverage available to the UE. While it should not be necessary for the UE to access these other networks⁶, the UE and the location process should be able to make use of the signals from these sources in addition to those of the serving network. It is critical to positioning accuracy that as many measurements are used as possible. This is particularly important in regions where the serving operator may provide coverage with only a single base station. Typically there will be additional coverage of these regions by other operators, but perhaps only from one base station from each operator. By making measurements of the signals from several operators the UE will typically be able to obtain information to make a better location estimate than would be possible with just the signals from a single operator⁷. The use of signals and other information from several operators would, of course, be subject to suitable operator agreement.

In some cases the UE may be able to operate in other modes (e.g. GSM) for which a location service feature is also provided. The signals of the other mode and location information may be helpful to the UTRAN LCS. For example, measurements of the GSM signals may be used by the UTRAN LCS calculation function to supplement the UTRAN radio measurements. The use of this information would, of course, be subject to suitable operator agreements. The techniques for this inter-mode operation and any signalling between networks are FFS.

⁶ Note that the UE does not need to access a foreign network in order to make OTDOA measurements of the downlink signals.

⁷ This assumes that the operators do not use co-located base stations.

The positioning process shall include the option to accommodate several techniques of measurement and processing to ensure evolution to follow changing service requirements and to take advantage of advancing technology. The information sources and the signalling required for their interaction, are FFS.

5 Technical service requirements

5.1 Requirements framework

[Editorial note : these items have been adapted from the UMTS 22.05 document. Some changes and additions have been made to reflect the new UTRAN environment. For example the Internal LCS of UTRAN may place additional requirements beyond those listed here for commercial or emergency service.

These items are provided here to give guidance for the LCS system design. The LCS system design should provide support for these various items. However, some implementations or networks may not include all of the items.]

The basis for the location feature the system design is outlined in the following points.

1. It shall be possible to make the location information available to the UE, to the network operator, a service provider, to the UTRAN internal operations and other value added services.
2. The user shall be able to restrict access to the location information either permanently or on a call-by-call basis. The network operator may override this restriction when appropriate for emergency calls, to track stolen UE or for UTRAN internal operations.
3. It shall be possible to set the response time for location requests. The urgency of the information request is quite different if the information is needed for call routing or for a subscriber application.
4. It shall be possible to have the location reports be updated regularly and to set the frequency of the reporting. The reports may be distributed to different clients at different rates.
5. It shall be possible to report when a UE enters or leaves a specified geographic area.
6. If the UE is powered off, it shall be possible to report the last known location together with the time and date of the last report.
7. It shall be possible to report the accuracy of the location report as a resolution that will be limited by the accuracy capability of the local serving UTRAN and the capability of the UE. Note that certain effects, such as multipath propagation, may lead to one-sided errors and thus a non-circular location error zone is likely.
8. It shall be possible for the location service to be used by the majority of UE within the UTRAN area without compromising the radio transmission or the signalling capabilities of the radio system. The location service is not an occasional "emergency only" service.

9. It shall be possible for the location service to be used by both "active" UE (in the RLC connected mode) and by "idle" UE (that are in the idle mode).
10. It shall be possible for the location determining process to make use of several sources of information in determining the location. Propagation and deployment conditions may limit the number or quality of measurements or additional measurements may be possible. Some UE may also have additional (independent) sources of position information. The LCS shall be capable of making use of the restricted or the extra information as appropriate for the service being requested. The Commercial, Emergency and Internal LCS may each make use of different techniques and sources of information.
11. As no single technique may provide the needed accuracy or meet evolving service requirements, the location determining process shall be able to combine several techniques to accommodate local conditions and evolving and advancing technology.

[Editorial note : the following section has been adapted from the GSM 02.xx document⁸. Some changes have been made to reflect the new UTRAN environment. Some of these additions include use of the LCS for UTRAN internal operations and to accommodate Packet Switched Services. The material is used here as a nucleus to start the development of the LCS for UTRAN.]

Generally, the ITU has described the third generation systems as operating in three environments (outdoor vehicular, outdoor pedestrian and indoor). The LCS requirements for each of these environments may differ. A location estimate accurate to hundreds of metres may be of little value in an indoor environment, for example. Similarly, an estimate accurate to a few metres may be of little value to a vehicle moving at hundreds of kilometres per hour. These topics are FFS.]

5.2 Functional Requirements

5.2.1 Quality of Service (QoS)

5.2.1.1 Comments on accuracy requirements

The ST9 working group in ARIB has included a summary on different location based services in its report from December 1998 with corresponding requirements and accuracy demands. The required accuracy varies from 10m up to 500m or 1km, depending on applications.

It is not straight forward to set an exact accuracy requirement or accuracy limit for location services in a radio system. The achievable accuracy is highly dynamic in an operational system and the accuracy demand depends both on the end user needs and on the application. The achievable accuracy will vary between rural and urban environments because of varying radio propagation conditions and fading. Location information is not available uniformly in the network because the density of base stations and size of cells vary. Some users will also be outside radio coverage at some times. In a practical network it may not be possible to always estimate or guarantee very high levels of accuracy throughout the network because of these uncertainties. The achievable accuracy will be established during the localization process and the generated location information should carry an indication of estimated accuracy level at the time of location calculation.

One approach to establish the useful accuracy level is make it variable depending on application. Different applications demand different levels of positioning accuracy and other positioning performance parameters, so the levels of performance should be classified according to the type of applications. When an application requests the current location information of the mobile terminal, it can also indicate or require a certain (minimum) level of quality of the location indication. The quality of location information can involve parameters like accuracy, update frequency, time stamp, time-to-first-fix, reliability, continuity, etc in a feasible way. The quality of the generated location information can of course exceed the required level. In case location information is not available to the required quality level, the request can either be denied and the

⁸ Digital cellular telecommunications system (Phase 2+); Location Services (LCS); Service description, Stage 1 (GSM 02.xx) January 1999 Draft

service execution terminated, or the user accepts the lower quality information. The quality level requirement of each service (application) could be set both by the subscriber and the service provider. This kind of feature is described also in GSM.02.71, which differentiates between emergency and commercial services.

5.2.1.2 Horizontal Accuracy

For Commercial Services, the following is applicable:

Accuracy is application driven and is one of the negotiable QoS parameters. The precision of the location estimate shall be network design dependent, i.e., should be an operator's choice. This precision requirement may vary from one part of a network to another. The LCS shall allow an LCS Client to specify or negotiate the required horizontal accuracy. The LCS shall normally attempt to satisfy, or approach as closely as possible, the requested or negotiated accuracy when other quality of service parameters are not in conflict. The horizontal accuracy may range from a few tens of metres (e.g. for a taxi pickup or traveling instructions) to hundreds of metres (e.g. for a nearby restaurant directory).

For Emergency Services (where required by local regulatory requirements) the following requirements shall be met:

The LCS Server shall attempt to obtain the horizontal location of the calling UE, in terms of universal latitude and longitude coordinates, and shall provide this to an Emergency Service Provider. The accuracy shall be defined by local regulatory requirements. For example, to an accuracy of within 125 meters for at least 67% of calls in the United States. To provide for more stringent emergency service requirements in other countries, the LCS Server may provide higher accuracy.

NOTE: the LCS service provides the location service capabilities but the mechanism by which location is reported to an emergency service provider is outside the scope of this report.

For Internal Services, the horizontal accuracy is FFS [likely of the order of 100 metres.]

5.2.1.3 Vertical Accuracy

For Commercial Services, the following is applicable:

The LCS Server may provide the vertical location of an MS in terms of either absolute height/depth or relative height/depth to local ground level. The LCS Server shall allow a LCS Client to specify or negotiate the required vertical accuracy. The LCS Server shall normally attempt to satisfy, or approach as closely as possible, the requested or negotiated accuracy when other quality of service parameters are not in conflict. The vertical accuracy may range from a about ten metres (e.g. to resolve within 1 floor of a building) to hundreds of metres.

For Emergency Services (where required by local regulatory requirements) there is currently no requirement to report the vertical location. It may be expected that, in the long term, vertical resolution to within 1 floor of a building would be helpful for emergency service response.

For Internal Services, the vertical accuracy is FFS.

5.2.1.4 Response Time

For Commercial Services, the following is applicable:

Response Time is one of the negotiable QoS parameters. Support of time response QoS parameters by a UTRAN is optional. The LCS Server may allow a LCS Client to specify or negotiate the required response time either at provisioning or when the request is made. The LCS Server may optionally ignore any response time specified by the LCS Client that was not negotiated. If response time is not ignored, the LCS Server shall attempt to satisfy or approach it as closely as possible when other quality of service parameters are not in conflict.

Response time is defined qualitatively as:

“no delay” : the LCS server shall return any location estimate that it already has for the UE (This estimate shall be supplied together with the time the estimate was made. If the estimate is “old”, the server may also initiate procedures to obtain a location estimate to be returned later. If no estimate is available, the LCS server shall return a failure indication and may initiate procedures to obtain a location estimate (e.g. to be available for a later request).

“low delay” : the LCS server shall return a location estimate in real time with precedence over fulfilling any accuracy requirement.

“delay tolerant” : the LCS server shall attempt to fulfill the accuracy requirement with precedence over returning a location estimate in real time.

NOTE: Real time may be equated with the typical delay between originating a voice call and receiving ringing tone. [This time is of the order of [] second in some networks.]

For Emergency Services (where required by local regulatory requirements) there may be no requirement to support negotiation of response time. The LCS Server shall provide a response as quickly as possible with minimum delay.

The response times required for Internal Services are FFS.

5.2.1.5 Priority

For Commercial Services, the following is applicable:

The LCS Server may allow different location requests to be assigned different levels of priority. A location request with a higher priority may be accorded faster access to resources than one with a lower priority and may receive a faster, more reliable and/or more accurate location estimate.

For Emergency Services (where required by local regulatory requirements) the location request shall be processed with the highest priority level.

For Internal Services, the priority assignments are FFS.

5.2.2 Timestamp

The LCS Server shall timestamp all location estimates provided to a LCS Client indicating the time at which the estimate was made.

5.2.3 Security

[Editorial Note : The LCS Phase 1 security and privacy related issues were presented to SMG10 in their Stockholm meeting the last week in March according to LCS Stage 1 and LCS Stage 2 documents, 02.71 and 03.71 respectively.

SMG10 had several comments and questions related to LCS, which are relevant also for UMTS. SMG 10 will send a liaison statement to T1P1.]

5.2.3.1 Authorisation

The LCS client may be authorised by the LCS server. UTRAN general security mechanisms as well as security mechanisms of the LCS server shall be used for authorizing the LCS client and its request for location information⁹. The security mechanisms to be used for LCS are FFS.

For Commercial Services, the following is applicable:

The LCS shall be made available only to authorised LCS clients. Before providing the location of a UE to any authorised LCS Client, the LCS server shall verify both the identity and authorisation privileges of the client. Once the LCS server has verified that a particular client is authorized to locate a particular UE, any location estimate requested shall be provided to the client in a secure and reliable manner, such that the location information is neither lost, corrupted nor made available to any unauthorised third party. Audit records of the requests and results for the LCS service should be kept (e.g. together with account billing records) to permit resolution of authorisation violations or other security breaches.

For Emergency Services (where required by local regulatory requirements) the following requirements shall be met :

Position information shall be provided to the Emergency Services client as an authorised LCS client. UE authorisation checks normally performed for commercial services are not applicable (privacy is over-ridden). The position information shall be provided to the Emergency Services client in a secure and reliable manner, such that the location information is neither lost, corrupted, nor made available to any unauthorised third party. Audit records of the requests and results for the LCS service should be kept (e.g. together with account billing records) to verify accuracy of reports and to permit resolution of authorisation violations or other security breaches.

For Internal services, the UTRAN Internal Clients shall be authorised by the LCS servers and shall make use of the location information in a secure and reliable manner, such that the location information is neither lost, corrupted, nor made available to any unauthorised third party. Audit records of the requests and results for the LCS service should be kept (e.g. together with account billing records) to permit resolution of authorisation violations or other security breaches.

5.2.3.2 Privacy

For Commercial Services, the following is applicable:

The user shall be able to restrict access to the location information (permanently or on a per attempt basis). The default treatment in the absence of information to the contrary in the UE

⁹ e.g. the LCS server will verify (authenticate) the right of the LCS client to request the Location information. This may become difficult if the Client is acting a proxy for a (distant) Internet application. The UE subscriber may access an Internet application (over the air) and the interaction may cause the UE to request location information.

subscription profile shall be to assume that access is denied to all LCS clients. The restriction can be overridden by the network operator when appropriate (e.g. emergency calls). The subscribers shall have the capability of controlling the ability for LCS to determine the subscriber's location in various circumstances. The home network shall have the capability of defining the default circumstances in which the subscriber's location is allowed to be provided as required by various administrations and/or network requirements. The LCS shall enable each UE to subscribe to self-location whereby the UE is allowed to request its own location from the UTRAN. In the context of this request, UE privacy is not a concern.

For Emergency Services (where required by local regulatory requirements) UEs/handsets making an emergency call may be positioned regardless of the privacy attribute value of the subscriber associated with the UE (or the handset) making the call.

For Internal Services, any authorised Client may obtain location information about the UE.

5.2.4 Feature Support

5.2.4.1 Roaming UE

For Commercial Services, the following is applicable:

Provided that a roaming agreement exists, the LCS feature shall allow any properly authorized LCS client to request and receive the location of a particular UE when the UE is either located in its home UTRAN or roaming outside. In all cases, the LCS feature shall support conveyance in a universal standard format of both the location QoS requirements of the client and the location information returned to the LCS Client. Any network not supporting the LCS feature shall return a suitable error response to any other UTRAN from which an LCS request is received. The requesting UTRAN shall then infer that the LCS feature is not supported and provide a suitable error response in turn to the requesting LCS Client.

For Emergency Services (where required by local regulatory requirements) there is no requirement for a home UTRAN to support positioning of target UEs that have roamed outside the home network.

For Internal Services, LCS may be used for Roaming UE.

5.2.4.2 Roaming UE Client

For Commercial Services, provided that a roaming agreement exists, the LCS feature shall allow any properly authorized roaming UE client to request and receive the LCS service over any permitted UEs when the UE client is roaming outside its home network.

For Emergency Services (where required by local regulatory requirements), there is no requirement to support a roaming UE client.

For Internal Services, LCS may be used for Roaming UE Client.

5.2.4.3 Support for all Handsets

For Commercial Services, support of all handsets is TBD.

For Emergency Services (where required by local regulatory requirements), positioning shall be supported for all UTRAN handsets where coverage is provided.

For Internal Services, it is FFS if LCS may be used for all handsets.

5.2.4.4 Support for Roaming Subscribers

For commercial services, support for roaming subscribers may be provided by the UTRAN.

For Emergency Services (where required by local regulatory requirements), the UTRAN shall support positioning of all UEs where coverage is provided (i.e. the UTRAN shall position all UEs that have roamed into its coverage area).

For Internal Services, LCS may be used for Roaming Subscribers.

5.2.4.5 Support for Unregistered Handsets

For Commercial and Internal services, support of unregistered handsets for LCS may be provided by the UTRAN.

For Emergency Services (where required by local regulatory requirements), the UTRAN shall support positioning for unregistered handsets. (i.e. including stolen handsets and handsets without a SIM).

5.2.5 Periodic Location Reporting

For Commercial and Internal services, support of periodic location reporting may be provided by the UTRAN. This item is FFS.

6 UTRAN LCS Architecture

The following figure shows the general arrangement of the Location Service feature. LCS entities are added to the UTRAN to provide the location service. Communication among these entities makes use of the messaging and signalling capabilities of the UTRAN across the Iu, Iur, Iub and Uu interfaces. A Location Measurement Unit (LMU) is also added to the UTRAN to make measurements as needed by the selected location method.

This figure does not include all the elements of the next generation mobile network, but focuses on those that participate with the LCS functions in the UTRAN.

As part of their service or operation, the LCS user or system applications may request information about the location of User Equipment (UE) (or group of UE) or mobile stations. There may be more than one LCS user or system application. These may be associated with the network, operated as part of the network, operated as part of a UE application or accessed by the UE through its access to a remote application (e.g. through the Internet). The internal operating procedures of the UTRAN may also make use of information about the location of the UE for such things as location-assisted handover, fleet management or home location billing.

The LCS users or system applications make their requests for location information to LCS functional entities. The LCS entities authenticate the LCS user or system application and then coordinate the resources of the UTRAN (including the Serving RNC, the Node-Bs, the UE, measurement and calculation functions) to estimate the location of the UE and return the result to the LCS application.

Within the UTRAN, the LCS Entities may be associated with, or part of the RNC, the Node-B and the UE. Internal LCS Applications may also be part of the RNC and the UE. The association of the LCS entities within the Core Network (CN) (e.g. with 3G-MSC or 3G-SGSN) is outside the scope of this document and is not illustrated in the diagram.

As part of this process the LCS entities may make use of information from auxiliary sources of information and other systems (outside UTRAN) such as navigation services. The location information returned to the internal or external application will provide an estimate of the accuracy of the estimate and the time-of-day the measurement was made.

Implementations may often associate the UTRAN LCS Entities with an RNC (as illustrated in the figure). However, for networks with a small volume of LCS requests, the LCS Entities in the UTRAN may also be implemented as a separate element which interfaces with the RNCs, the Core LCS entities and the Node-B/LMUs.

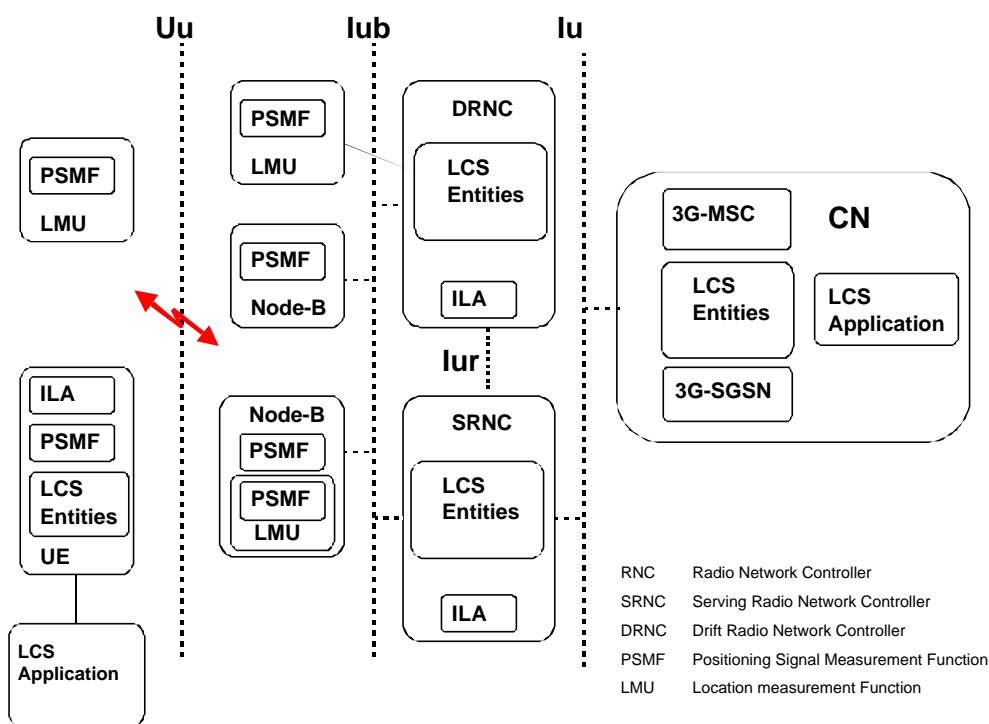

FIGURE General Arrangement of LCS

6.1 Interfaces

There are four interfaces through which the LCS entities communicate. These are the Iu, the Iur, Iub and the Uu.

Note : the interfaces between the Internal or External LCS applications and the 3G-MSC or 3G-SGSN are outside the scope of this document.

6.1.1 Iu Interface

The Iu interface is used to communicate between the LCS functional entities in the Core Network and the LCS entities in the UTRAN.

This interface passes the location requests from authenticated external and internal LCS applications between the LCS entities in the Core network and UTRAN. The location request will include parameters to indicate the preferred location method and the quality of service (QoS). The QoS parameters will include the required speed of response, the preferred coordinate system and the required accuracy. The location results, error (failure) responses, and accounting/OAM information will be returned from the LCS entities in the UTRAN to the LCS entities in the core network.

The LCS entities in the UTRAN may also request from the core LCS entities information concerning the client subscriptions and UE privacy conditions that may be needed to support internal LCS application requests.

The Iu interface may also pass messages relating to changes or reporting of the data associated with the Location System Operations Function (LSOF) in the LCS entities associated with the Core network or the UTRAN.

6.1.2 Iur Interface

The Iur interface is used to communicate between the LCS functional entities associated with the serving RNC and other RNC in the UTRAN. The Iur interface is also used to communicate between the serving RNC and the Internal LCS Applications in the UTRAN. The LCS entities associated with the serving RNC are responsible for coordinating and responding to location requests received from the LCS entities in the core network or Internal Clients

When communicating between the serving RNC and the UTRAN Internal LCS Applications (ILA), the messages and protocols are the same as those used over the Iu interface.

The Iur interface is also used to communicate between the LCS Entities in the serving RNC and those in other RNC. The location method, for example, may require measurements by several LMU or Node-B, some of which may be associated with other RNC. Commands and responses from these LCS Entities are communicated over the Iur interface. In some cases, the LCS Entities in the serving RNC may make use of entities associated with other RNC. For example, a calculating function (PCF) may be used in another RNC if the serving RNC is too busy or does not contain the function or database information required by the chosen location method.

The Iur interface may also pass messages relating to changes or reporting of the data associated with the Location System Operations Function (LSOF) in the RNC.

6.1.3 Iub Interface

The Iub interface is used to communicate among the LCS entities associated with the serving RNC, the Node-B and the Location Measurement Units (LMU).

This interface passes the request for measurements, the measurement results and requests for LCS related transmissions or other radio operations needed by the location method (e.g. broadcast of parameters needed for a UE based location method).

The Iub interface may also pass messages relating to changes or reporting of the data associated with the Location System Operations Function (LSOF) in the Node-B or the LMU.

6.1.4 Uu Interface

The Iu interface is used to communicate among the LCS entities associated with the RNC, the UEs and the (remote) Location Measurement Units (LMU).

This interface may pass measurement requests and results to and from the UE or the remote LMU.

The Uu interface may also pass location requests from Internal or External LCS Applications at the UE. Note that these requests may require the services of the LCS entities associated with the core network to authenticate clients and subscriber subscriptions to aspects of the LCS.

The Uu interface may also be used for broadcast of information that may be used by the UE or (remote) LMU for their LCS operations. This may, for example, include timing and code information about nearby Node-B transmissions that may assist the UE or LMU in making their measurements.

The Uu interface may also pass messages relating to changes or reporting of the data associated with the Location System Operations Function (LSOF) in the UE or the remote LMU.

6.2 LCS Operations

The UTRAN LCS entities may receive authenticated requests for location information that originate in external applications across the Iu interface (for validated UE subscriptions).

Interworking between the External LCS Applications and the LCS entities within UTRAN is outside the scope of this document.

6.2.1 LCS Operation Basis

The operation begins with an External LCS application requesting location information for a UE. The application will pass the request to the LCS functional entities. The LCS entities will first verify the request and the application. If the application is authorised to access the LCS for the requested UE and the UE has not restricted access to the location information for its privacy, the UTRAN LCS functional entities will :

- request measurements, typically from the UE and the Node-B radio apparatus¹⁰,
- send the measurement results to the appropriate calculating function,
- receive the result from the calculating function,
- perform any needed coordinate transformations,
- send the results to the LCS application, and
- send appropriate accounting information to an accounting function.

As part of its operation, the calculating function may require additional information. This may be obtained by the function directly by communication with a database, or it may be through a request to LCS entities that will mediate the request and return of information from the appropriate database (or databases if more than one is needed to fulfill the requests). The LCS application may make use of the position information itself, or further process and then forward the information to other authorised applications within or external to the UTRAN.

There may possibly also be available independent information that is able to supply the location information directly, or may be able to supply auxiliary information to the calculation function. For example, a UE mobile equipped with navigation equipment (i.e. GPS), might be able to return the exact location information when the measurements are requested (instead of just some

¹⁰ several Node-B may be involved in measurements

measurements). The LCS coordination function, as part of its activity to supervise the positioning process, may query the UE or other elements of the network to determine their capabilities and use this information to select the mode of operation.

This general operation is outlined in the following (generic) sequence diagram. This figure is not intended to show the complete LCS operation, but to simply to outline the basis for operation within UTRAN.

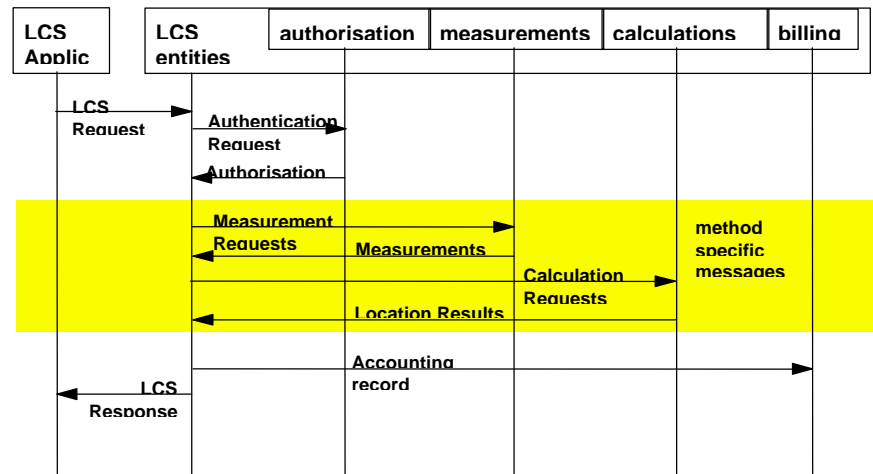

FIGURE general sequence for LCS operation

6.3 High-Level Functions

The following list gives the logical functional entities for the LCS. Several functional groupings are defined which encompass a number of smaller functions. These smaller functions are described in more detail in later sub-sections of this document.

The LCS Functional entities may be grouped as follows :

- The LCS application group.

- The group that deals with subscriptions, authorisations and general mobility management.

- The group that deals with processing, measurements and calculations within UTRAN.

- The UE (mobile unit) group.

6.3.1 LCS Application Functions

There are two classes of LCS Application – Internal applications and External applications. Internal applications represent entities internal to the UTRAN that make use of location information for the (improved) operation of the network. External applications represent entities (such as Commercial or Emergency services) that make use of location information for operations external to the mobile communications network. The LCS Applications interface to the LCS entities through their Location Client functions (LCF).

The interface between the external LCS applications and the LCS entities is outside the scope of this document.

6.3.2 Subscription and Authorisation Functions

The LCS Authorisation Functions are responsible for providing access and subscription authorisation for an LCS application. Specifically, these functions provide authorisation for an LCS application requesting access to the LCS functional entities and authorise the (LCS) subscription of an application. These entities are mainly concerned with Client and Subscriber authorisation, subscription, privacy and mobility and are thus located in the core network.

The Location Subscriber Authorisation Function is responsible for authorising the provision of a location service (LCS) for a particular subscriber using the UE. Specifically, this function validates that a LCS can be applied to a given subscriber. The LSAF verifies the UE's subscription to a requested LCS service. These two functions, together, are responsible for ensuring the privacy directives of the UE subscriber are complied with.

These entities communicate with other LCS entities in the UTRAN across the Iu interface to request and receive location information for authenticated LCS applications and subscribers.

The details of the subscription and authorisation functions are outside the scope of this document.

6.3.3 Coordination, Measurement and Calculation Functions

These functions provide the coordination, measurement and calculation functions needed to provide a location estimate. The functions interface with the requesting application and select the appropriate location method and speed of response. The functions coordinate the operations of the radio and measurement equipment to transmit the needed signals and to make the needed measurements. The measurements may be made by Node-Bs, radio apparatus associated with the Node-B or separate Location Measurement Units (LMU) that may be associated with Node-B, independently located or remote (i.e. communicating over the Uu interface). The functions may also access databases or other sources of information appropriate for the location method. The functions also provide the calculation functions appropriate for the location method to estimate the UE location and the accuracy of the report. The functions may also make coordinate translations to the geographic coordinate system requested by the application. The functions also may collect accounting information on the usage of the LCS that may be forwarded to (other) charging accounting and billing functions. If needed by the location method, the functions will ensure the broadcast of information for some (UE based) location methods and gather and update information concerning UTRAN operating parameters (e.g. timing of Node-B transmissions) needed for LCS operations.

These entities are mainly concerned with the location method, controlling the radio equipment and performing the calculations to determine the location and thus may be associated with the RNC in the UTRA access network. These functions may receive location requests from either the authorisation and subscription functions in the core network or from applications internal to the UTRAN. These coordination functions may also request the subscription and authorisation functions in the core network to authenticate an application or a UE subscription or to verify the subscriber privacy parameters.

These functions communicate with the core network across the Iu interface, with other entities in the UTRAN across the Iur interface and with the Node-B and LMU across the Iub interface and with the UE and the remote LMU across the Uu interface.

6.3.4 UE Functions

The UE interacts with the measurement coordination functions to transmit the needed signals for uplink based LCS measurements and to make measurements of downlink signals. The measurements to be made will be determined by the chosen location method.

The UE may also contain LCS applications, or access an LCS application through communication with a network accessed by the UE or an application residing in the UE. This application may include the needed measurement and calculation functions to determine the UE's location with or without assistance of the UTRAN LCS entities.

The UE may also, for example, contain an independent location function (e.g. Global Satellite Positioning Service GPS) and thus be able to report its location, independent of the UTRAN transmissions. The UE with an independent location function may also make use of information broadcast by the UTRAN that assists the function.

6.4 Logical Architecture

This section describes the LCS logical architecture. The LCS logical diagram, shown in the following figure, depicts the relation of the LCS applications and the LCS functional entities. The diagram also illustrates the functional decomposition of the UTRAN LCS functional entities into individual logical functions. Later sub-sections provide details of the functional entities and their interfaces.

(Note this decomposition of functional entities follows the GSM. This arrangement has been retained together with the nomenclature in order to facilitate evolution from GSM systems. Some text has been amended and some additional text details have been added.)

This sub-section illustrates logical entities developed for the purpose of describing the standard LCS operation. These do not necessarily represent physical entities and implementations may combine the logical entities in various physical arrangements as appropriate. Various of the entities may be present in either or both the UTRAN fixed network or in the UE handset or associated apparatus. It is intended that these entities be general (generic) in nature in order that improved performance and efficiency can be achieved by adopting new techniques and procedures over the (many years) lifetime of the UTRAN operation. Not all implementations need include all entities and this description is not intended to preclude entities or operations that may be added to provide additional features.

The functional model includes all the entities needed for different location methods (i.e. network based, mobile based, mobile assisted, and network assisted¹¹) and may utilise either uplink or downlink measurements, or both. The location method may also make use of measurements of transmissions outside the UTRAN. The method may combine measurements of several types in order to obtain the highest accuracy.

¹¹ In this approach the UE may use the GPS positioning mechanism but still make use of auxiliary measurements from the serving network.

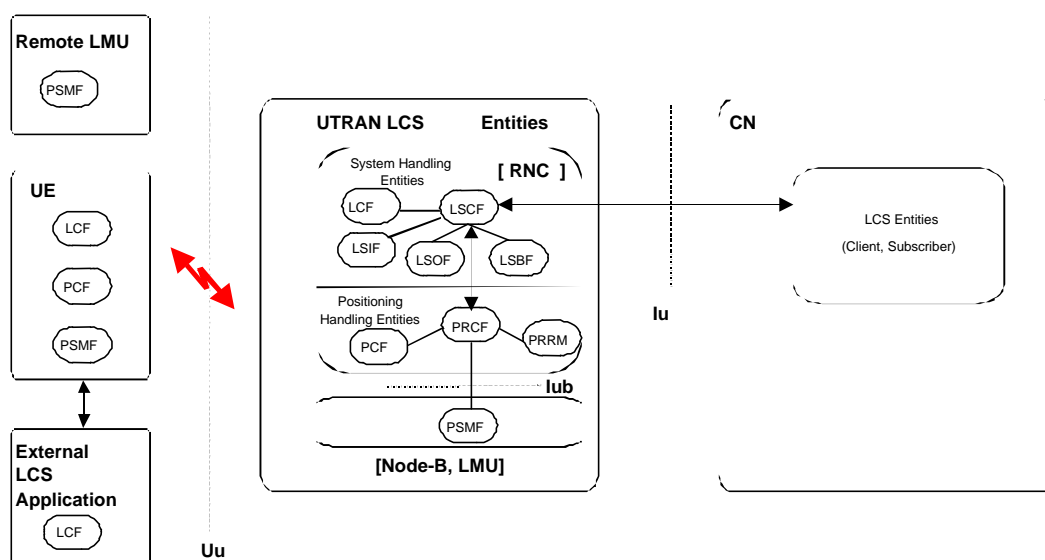

Figure LCS Functional Entities

The System Handling entities and the Positioning Handling entities are illustrated as being logically associated with the RNC in the UTRAN. The System Handling entities include

- the Location System Control Function (LSCF),
- the Location System Billing Function (LSBF),
- the Location System Information Function (LSIF) and
- the Location System Operation Function (LSOF).

The LSCF interfaces with the Client Handling entities across the Iu interface and receives the authenticated location requests and returns the results. The LSCF interfaces with the Positioning Handling Entities to request the measurements and calculations appropriate for the location technique being used for the request. The LSCF also interfaces with the LSIF to initiate and maintain the broadcast of information for use by location methods that may operate at the UE.

The Positioning Handling entities include

- the Positioning Radio Coordination Function (PRCF),
- the Positioning Radio Resource Management (PRRM),
- the Positioning Calculation Function (PCF) and
- the Positioning Signal Measurement Function (PSMF).

These entities manage the radio resources, make the necessary transmissions and measurements and perform the calculations. The PRCF will return the results of the calculations from the PCF to the LSCF in the system handling entities for return to the LSCF in the client handling entities. The PRCF, PRRM and PCF will typically reside in the RNC while the PSMF will typically reside in the Node-B or an LMU. A location method may require the use of PSMF operating in several Node-B and (or) LMU.

Associated with each of the entities is a Location System Operations Function (LSOF) which contains the necessary data used for the operation of the entity. This data is maintained by an OAM maintenance client operating in the core network.

These entities are shown to be associated with the RNC as this is the source of most of the measurement and radio control activity.

The Iu connections between the core network and the access network are indicated by the dotted line Iu. There may be several RNCs involved in the LCS operation. The LSCF associated with the Serving RNC (SRNC) acts on the LCS request and collects LCS information from other RNCs, if needed. The Drift RNC (DRNC) may become involved in LCS because of macrodiversity and soft handover. Also, Node-B not belonging to the Serving RNC (SRNC) or DRNC may be used for LCS measurements. These PSMF will be accessed by the PRCF in the serving RNC.

6.4.1 LCS Application

Note : The LCS Application's internal logic and its interface to the external user is outside the scope of this document. This text is provided here for explanatory purposes only.

An LCS application is a logical functional entity that requests from the LCS functional entities, location information for one, or more than one, UE within a specified set of parameters such as Quality of Service (QoS). The LCS application may reside in an entity (including the UE) within the UTRA network or in an entity external to the UTRA network.

LCS applications may be of two types, Internal; and External. Internal applications represent entities internal to the UTRAN that make use of location information for the (improved) operation of the network. External applications represent entities (such as Commercial or Emergency services) that make use of location information for operations external to the mobile communications network.

The LCS Applications interface to the LCS entities through their Location Client functions (LCF).

6.4.1.1 Location Client Function (LCF)

Note : The Location Client Function internal logic and its interface is outside the scope of this document. This text is provided here for explanatory purposes only.

The Location Client Function provides a logical interface between the LCS application and the LCS functional entities. This function is responsible for requesting location information for one or more UEs with a specified "QoS" and receiving a response, which contains either location information or a failure indicator.

The Location Client Function (LCF) provides the interface between internal or external LCS Applications and the LCS entities (e.g. either the Location Client Control Function (LCCF) in the Core network, or the Location System Control Function (LSCF) in the UTRAN).

6.4.2 UTRAN LCS Entities

The UTRAN LCS entities receive the authenticated requests for location information from the CN and also from Internal (UTRAN) applications. The System Handling entities and the

Positioning Handling entities make measurements and calculate the location and return the result to the source of the request. The UTRAN LCS entities may be associated with (or part of) the RNC within the UTRAN.

6.4.2.1 Location System Control Function (LSCF)

The Location System Control Function is responsible for coordinating location requests within the System handling entity. This function manages call-related and non-call-related positioning requests and allocates network resources for handling them.

The LSCF provides flow control between simultaneous location requests. Simultaneous location requests must be queued in a controlled manner to account for priority requests (e.g. for Emergency Clients). The details of the flow control, priority selection and queuing are beyond the scope of this document.

The LSCF will select the appropriate location method based on the availability of resources and parameters of the location request. The LSCF performs call setup if required by the location method (e.g., putting the UE in a dedicated mode and obtaining Cell-ID). The LSCF coordinates resources and activities needed to obtain data (e.g. base station geographic coordinates) needed for the location method. It also collects charging and billing related data for the location service request and passes this to the Location System Billing Function (LSBF).

If the location technique requires the broadcast of system information, the LSCF initiates and maintains this activity through the Location System Information Function (LSIF). Broadcast information (such as the geographic coordinates of the base stations) may be required, for example, to support a Position Calculation Function (PCF) located in the mobile unit (UE).

The LSCF interfaces with the LCF, LCCF, LSAF, LSIF, LSBF and PRCF. Using these interfaces, it conveys location requests to the PRCF, relays location results to the LCF or LCCF and passes accounting related data to the LSBF.

If the LCF represents an Operation Administration or Maintenance (OAM) Client, then the LCCF will interface through the LSCF in the System Handling Entities to (for example) update information in the Location System Operations Function (LSOF) or retrieve charging records from the Location System Billing Function (LSBF).

6.4.2.2 Location System Billing Function (LSBF)

The Location System Billing Function is responsible for recording activity related to location services that may result in accounting, charging or billing functions. The LSBF may also be responsible for collection of operational information about usage of the LCS. This may include records of both clients and subscribers and collection of related data for accounting between UTRANs and other networks. The details of the records or the accounting, charging, billing operations and maintenance functions are outside the scope of this document.

The LSBF interfaces to the LSCF and its records may be accessed by an OAM Client. The LSBF may, in addition, interface directly to an external charging/billing system. The details of such an external interface are outside the scope of this document.

6.4.2.3 Location System Operations Function (LSOF)

The Location System Operations Function is responsible for provisioning of data, positioning capabilities, data related to clients and subscription (LCS client data and UE data), validation, fault management and performance management of LCS.

An LSOF may be associated with each entity. The LSOF interacts with Internal (OAM) Clients for administration and maintenance of the data.

6.4.2.4 Location System Information Function (LSIF)

The Location System Information Function is responsible for ensuring the broadcast of location information for use by UE (or LMU). This information may include, for example the geographic location of the base station, the local time-of-day, the timing offsets of the transmitted signals (RTD). These broadcasts may also include other information (such as currently observable satellites) that may assist a UE in the use of external location services.

The information to be broadcast is selected based on the location techniques offered for use by the LCS and the needs of the UE. This broadcast information may be specially coded (i.e. encrypted) to ensure its availability only to subscribers of the service. The use of broadcasts or other methods for signalling to the UE or the LMU may be selected based on the chosen location method.

6.4.3 Positioning Handling Entities

6.4.3.1 Positioning Radio Coordination Function (PRCF)

The Positioning Radio Control Function manages a location request for a UE through overall coordination and scheduling of resources to perform location measurements. This function interfaces with the PSMF, the PRRM and the PCF. The PRCF determines the location method to be used based on the location request, the QoS, the capabilities of the network, and the UE's capabilities. The PRCF also manages the needed radio resources through the PRRM. It determines which PSMFs are to be involved, what to measure, and obtains processed signal measurements from the PSMF. The PRCF also forwards the signal measurement data to the PCF.

Some location methods may involve measurements made at the UE. In this case the PRCF interfaces with the UE to obtain the measurements (or the location results if they have been determined by the UE). Some location methods may involve measurements or information from several sources, including radio units at several Node-B (or other Location Measurement Units (LMU)) and involve a series of transmissions and receptions. It is the function of the PRCF to coordinate the sequence of activities and compensate for failures (if they occur) to provide the best available location estimate.

6.4.3.2 Positioning Calculation Function (PCF)

The Positioning Calculation Function is responsible for calculating the location of the mobile. This function applies an algorithmic computation on the collected signal measurements to compute the final location estimate and accuracy. It may also support conversion of the location estimate between different geographic reference systems. It may obtain related data (e.g., base

station geographic co-ordinates) needed for the calculation. There may be more than one calculating function available within, or associated with, the positioning entity of the UTRAN.

The Position Calculation Function is also responsible for estimating the accuracy of the location estimate. This accuracy estimate should include, for example, the effect of geometric dilution of precision (GDP), the capabilities of the signal measuring hardware, the effects of multipath propagation and the effects of timing and synchronisation unknowns. The accuracy should be returned as a measure of distance in the same units as the location estimate. The accuracy zone may be reported as the axis and orientation of an ellipse surrounding the location estimate.

6.4.3.3 Positioning Signal Measurement Function (PSMF)

The Positioning Signal Measurement Function (PSMF) is responsible for performing and gathering uplink or downlink radio signal measurements for use in the calculation of a mobile's location. These measurements can be location related or ancillary.

There may be one or more PSMF within a UTRAN and they may be located at the UE, the Node-B, or a separate Location Measurement Unit (LMU). The PSMF, generally, may provide measurement of signals (i.e. satellite signals) in addition to measurements of the UTRA radio transmissions. The measurements to be made will depend on the selected location method.

6.4.3.4 Positioning Radio Resource Management (PRRM)

The Positioning Radio Resource Management entity is responsible for managing the effect of LCS operations on the overall performance of the radio network. This may ensure, for example, that the operation of the PSMF does not degrade the QoS of other calls. The PRRM handles following functions :

- Controlling the variation of the UL and DL signal power level due to the LCS application.

- Calculating the DL and UL power/interference due to UE positioning.

- To admit/reject the new LCS requests.

- Cooperating with Admission Control, and entities of the RRM (such as power control) to provide the system stability in terms of radio resources.

- Controlling the RTD measurement mechanism. It may also forward the results of the RTD, ATD (or any similar timing parameter) measurements to the PRCF.

- Controlling the IS-DL mechanism¹² for positioning measurements. This may include the overall control of the periodic measurements fulfillment.

6.4.4 Location Measurement Unit (LMU)

The Location Measurement Unit LMU entity makes measurements (e.g. of radio signals) and communicates these measurements to the PRCF. The LMU contains a PSMF and also may also perform calculations associated with the measurements.

The LMU may be associated with the Node-B and make use of its radio apparatus and antennas. Alternatively, the LMU may be separated from the Node-B, but communicate with the PRCF via the Node-B Iub interface. Independent LMU may also be used, these may communicate to the

¹² IS-DL: Idle Slot – Down Link

PRCF via the Uu interface or may otherwise communicate to the PRCF (through an interface yet to be defined).

The LMU may make its measurements in response to requests (e.g. from the PRCF), or it may autonomously measure and report regularly (e.g. timing of Node-B transmissions) or when there are significant changes in radio conditions (e.g. changes in the RTD).

There may be one or more LMU associated with the UTRAN and an LCS request may involve measurements by one or more LMU. The LMU may be of several types and the PRCF will select the appropriate LMUs depending on the LCS method being used.

The LMU may be used, for example, to measure UTRA radio transmissions either uplink or downlink. These measurements may be made either, for example, to locate the UE or to measure a system parameter needed by the LCS system such as the timing offset (RTD) of transmissions of two or more base stations. The LMU may also measure other transmissions, such as those of satellite navigation systems (i.e. the Global Positioning System (GPS)) and either report the measurements for use by the PCF of the LCS system, or report the location results as determined by internal calculations of the LMU.) The details of the measurements to be made by the LMU will be set by the chosen LCS method.

6.5 Allocation of functional entities to network entities

The preceding Figure and the following Table show the generic configuration for different positioning methods, including network-based, mobile-based, mobile-assisted and network-assisted positioning methods. With this approach both the network and the mobiles are able to measure the timing of signals and compute the mobile's location estimate. Depending on the applied positioning method it is possible to utilise the corresponding configuration containing all needed entities. For instance, if network-based positioning is applied, the entities that are involved in measuring the mobile's signal and calculating its location estimate are allocated to the network elements of the access stratum. On the other hand, in case mobile-based or network-assisted methods are used these entities should be allocated to the mobile station.

	UE	Node-B	LMU	RNC
LCF	X			X
LSCF				X
LSBF				X
LSIF				X
PRCF				X
PCF	X			X
PRRM				X
PSMF	X	X	X	
LSOF	X	X	X	X

Table Allocation of LCS Functional Entities to Network Elements

7 Technical operations

[Editorial note : Generally this description outlines the OTDOA technique for FDD systems. Further contributions are solicited on the use of other techniques and for TDD systems.]

The general LCS feature outline in the previous section is described independently of the details of the technology/technique used for measuring the position. The following section outlines in more detail the expected technique of operation for the OTDOA technique. This description outlines, with some generalities, one way to make use of the technique. It is not intended to preclude other techniques or operations from being used in addition or as alternatives. The standard may include several alternative techniques that may be selected by the operator to suit their service needs.

It should be noted that the accuracy of the location determination depends on many factors. These include, the accuracy of the measurements made, the number of measurements made, the averaging technique if it is used, the accuracy of the available database information, the effects of multipath propagation and the techniques for error reduction that may be included in the calculation function. The accuracy of the location determination is to be reported with the measurement and the objectives for accuracy, although set by the operator, are constrained by the capability of the equipment, the radio propagation conditions at the time of measurement, and the needs of the requesting application.

7.1 Operation of OTDOA technique

The OTDOA technique is based on measurements at the UE of the observed time difference of arrival between the downlink signals received from a number of base stations. These measurements are then sent to the calculation function together with the identity of the base stations. For reasons given in more detail later, the measurements need to be accompanied by information concerning the time-of-day that they were made. The calculation function will then obtain from the database the surveyed geographic position of the base stations that have been measured. The calculation process also needs to know the relative time difference (termed RTD) (“synchronisation”) of the actual downlink transmissions of each of the base stations. With these three basic inputs, the calculation function may estimate the geographic location of the UE. The estimate, together with the estimate of errors may be returned to the LCS Client. This is illustrated in the following figure.

¹³ several Node-B may be involved in measurements

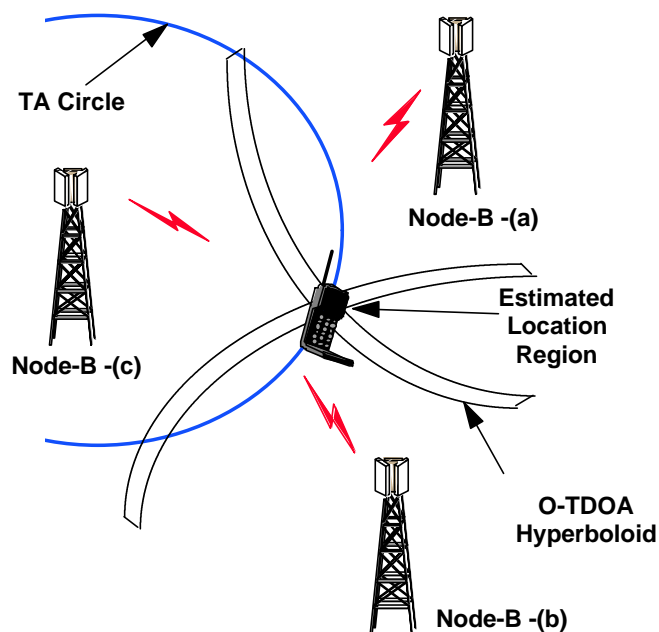

FIGURE Base Stations and the Location Estimate

While the exact downlink signals to be measured by the UE are FFS, it is expected that the synchronisation channel will be one of the signals. This signal is a suitable choice because it is available from all base stations and has been designed for rapid acquisition to facilitate handover operations by the UE. These signals can also be measured by both idle and active UE and may be measured for many base stations, including transmissions from base stations other than the UE's chosen operator. The measurement of the timing difference between the synchronisation signals is also used as part of the handover process to obtain the necessary timing correction required to facilitate soft-handover, or simultaneous transmission of downlink signals, from two or more base stations. This timing measurement, perhaps to a higher degree of accuracy, is suitable for the LCS process. It is expected that some additional elements of hardware and software may be required in the UE to measure and report the LCS OTDOA data.

7.1.1 Accuracy

In the OTDOA technique, generally, the location is being determined by means of an estimate of the transit time (time-of-flight) of the radio signals. The radio path and the geographical path are assumed to be the same with unobstructed line-of-sight. The radio signals travel about 0,3 metres per nanosecond. To achieve an uncertainty of less than 50 metres in the location estimate requires an uncertainty in timing of less than 166 nanoseconds. With a 4 Mchip/s rate, the chip duration is 250 nanoseconds and ultimately, LCS requires timing measurements of the radio signals to the sub-chip level. Many current receivers are capable of combining multipath signal components to the sub-chip level of timing (often to better than 1/4 chip), and so such timing accuracy is already available, although in a different form.

The radio signal path is, unfortunately, not always equal to the geographic separation. The effects of multipath and obstructions combine to make the radio path typically longer¹⁴ than the geographic path. A distance estimate derived from radio signal timing will generally be longer than the true distance. The techniques to mitigate the effects of multipath in the LCS are beyond the scope of this report and are, in any case, subjects of current active technology research. These can be expected to improve with experience in system operation and the measurement function and calculation function designs can be expected to evolve to give better performance over the lifetime of deployed UTRAN LCS.

The accuracy of the location estimate may thus vary from area to area within an operator's territory due to the effects of multipath propagation. Some operators may choose to add extra base stations or extra transmissions to provide better location service accuracy in areas they deem critical for their service. Other operators may choose to have fewer base stations and consequently a lower accuracy service in some areas.

The objective is to provide the best estimate available with the equipment, measurements and propagation conditions prevailing at the time and place of the UE. Not all results will be of the same precision and there is a cost associated with increased precision. Making use of a downlink based measurement technique minimises the network traffic and provides a system that scales with increased usage by UE. In some jurisdictions, the equipment must meet some minimum requirements to satisfy regulatory requirements for accuracy of the location service (such as FCC in the United States) and this must be taken into consideration in the design of equipment for operation in these areas.

Generally the measurement of position is a statistical process and not all measurements of the same location will yield the same result. The overall system accuracy of its reports (e.g. less than 100 metres error in 80% of measurements) will involve a statistical measure of many operations at many times and at many locations through the UTRAN coverage area. The accuracy reported together with an individual report must take into account the individual measurements, environmental conditions and the time of the measurement. The accuracy reported for an individual measurement may vary considerably from the overall system performance statistic.

7.1.2 Relative Time Difference (RTD)

In order to calculate the estimate of the location of the UE, the calculation function needs to know

- the OTDOA measurements,
- the surveyed geographic locations of the base stations that have had their signals measured,
- and
- the actual relative time difference between the transmissions of the base stations at the time the OTDOA measurements were made.

The accuracy of each of these measurements contributes to the overall accuracy of the location estimate. The measurement of the RTD is FFS.

¹⁴ (but never shorter)

There are several approaches to determining the RTD. One is to synchronise the transmissions of the base stations. In this technique the RTD are known constant values¹⁵ that may be entered in the database and used by the calculation function when making a location estimate. The synchronisation must be done to a level of accuracy of the order of tens of nanoseconds (as 10 nanoseconds uncertainty contributes 3 metres error in the position estimate). Drift and jitter in the synchronisation timing must also be well controlled as these also contribute uncertainty in the location estimate. Synchronisation to this level of accuracy is currently only readily available through satellite based time-transfer techniques. Generally in the TDD operating mode, the base stations are synchronised.

Alternatively (typically in FDD mode), the base stations may be left to free run within some constraint of maximum frequency error. In this scenario, the RTD will change (slowly) with time. The rate of change will depend on the frequency difference and jitter between base stations. If, for example, the maximum frequency difference between two base stations is $\pm 10^{-9}$, then the start of transmission of a 10 millisecond code sequence will drift through a cycle in about 1390 hours (or 57 days). With this relatively slow rate of drift the RTD can be measured by fixed units at known locations and stored in the database for use by the calculation function. The jitter and drift of the individual oscillators in each base station may cause the change of timing to slow, remain constant or reverse direction over time. Ongoing measurements of the RTD may be made to assure the most current values are available for the calculation function. The RTD measurement units may be co-located with the base stations or installed at other convenient locations in the UTRAN coverage area, and report their results through the UTRAN signalling channels.

7.1.3 Time-of-Day (ToD)

If there are frequency differences between the (unsynchronised) base stations, as noted in the previous sub-section, the OTDOA measurements must be reported together with the time-of-day they were made (timestamp). This is necessary so that the appropriate value of the RTD may be used by the calculation function.

In order to assure less than a 20 nanosecond uncertainty in the RTD value, the time of day must be known to better than 10 seconds (if the maximum frequency difference between the base stations is $\pm 10^{-9}$). The method by which the ToD is measured is FFS [, but the frame number (which provides a 10 millisecond resolution) or encryption counter used in the downlink transmissions may provide a convenient measure].

7.1.4 Observability (“Hearability”)

One of the concerns with the OTDOA technique is whether the UE will generally be able to receive signals from a multitude of base stations. Certainly a UE in the handover region between cells will be able to receive signals from multiple base stations. However, a UE that is located

¹⁵ The transmission times may all be aligned to a common reference (such as UTC) in which case all RTD have a common value. However, in a more general case the transmissions may have a fixed offset with reference to UTC, and thus the RTD values are non-zero and may be stored in the database for use by the calculation function.

very close to one of the base stations may be swamped by the strong local signals and be unable to receive signals from other base stations. There are several solutions.

Based on the results of the work done in ARIB SWG2/ST9 (Location Services), a candidate for ensuring observability is the IS-FL (Idle Slot Forward link) method. In this method each, each base station ceases its transmission for short periods (during an “idle” slot). During these idle downlink slots, UE within the cell can measure other base stations and the observability is improved. Also, during idle slots, the relative time difference measurements can be made. Because the IS-FL method is based on the forward link (downlink), the location service can be provided efficiently to a large number of UE simultaneously. The detailed specification of the physical channels and the idle slot selection and signalling to be used for the IS-FL are FFS.

As an alternative, a UE that is blocked because of strong local signals may simply report this information. Under these conditions, it is clearly located very close to the serving base station, and this together with a round trip time measurement and sector, may define the location to sufficient accuracy for some purposes. The topic of observability is FFS.

7.2 Round Trip Time

It is a useful addition to the downlink measurement (OTDOA) technique outlined in the previous section, for active UE¹⁶ to make use of the round trip time (RTT) parameter of the UTRAN radio system. This parameter measures the round trip delay of signals between the mobile and the serving base station. The round trip delay (divided by two) is an estimate of the time-of-flight of the radio signals from the base station to the UE and this establishes a circle of location about the base station for the mobile’s position. If the base station is using sectored antennas, then the RTT and sector define an arc of location for the UE.

The resolution of the RTT measurement sets the accuracy of this location estimate. An uncertainty of (say) 0,5 µsec translates into a 150 metre uncertainty in the radius of the arc. This timing uncertainty must include the effects of measurement resolution at the base station, uncertainties in the UE’s transmission timing resolution and multipath.

While the the RTT measurement in the UTRAN radio system may not very precisely determine the round trip signal timing, manufacturers of base stations and handsets may choose to develop units with improved measurement accuracy to provide better location estimates. There is, however, a need to standardise a minimum timing performance in mobiles for delay jitter to assure some level of accuracy for this measurement. The details of this are FFS. It is expected that some additional elements of hardware and software may be required in the Node-B to measure and report the RTT data.

Coupled with the OTDOA measurements and calculation, the RTT measurement can assist the accuracy of the location, by removing ambiguities at least, and should be a recognised part of the standard process. Use of the RTT measurement may, for example, enable a position estimate to be established with only OTDOA from two base stations (instead of three), if the geometry is good, or it may help in cases when the OTDOA for three base stations are available, but their geometry of position is poor (they are all on one side of the mobile for example).

¹⁶ those UE with active call in progress.

7.3 Angle of Arrival

[TBD This section provides an outline of aspects of the angle of arrival technique.]

7.4 Observed Time of Arrival

[TBD This section provides an outline of aspects of the observed time of arrival technique This may operate with either downlink or uplink signals (or perhaps both).]

7.5 General Navigation system assisted

[TBD This section provides an outline of aspects of general navigation system techniques that may be used for the LCS or to be combined with other techniques.]

7.6 Combined techniques

[TBD This section provides an outline various ways to combine the techniques and includes topics related to operations involving other modes such as GSM.]

8 Measurements

This section summarises the general requirements for the measurements to be made by the UE (mobile station) and the base station (node-B) for LCS operation.

[Editorial note: the timing requirements are expressed here in terms of fractions of chip duration. This is intended to relate the timing to the basic timing signals (the chip) available to the hardware. The nominal chip duration is considered to be 4 Mchip/s. This description was chosen in order that there would be no need to change the timing requirements should the chip duration be changed during the course of the UTRAN radio standard development. The requirements, expressed as chip fractions, need not change should the chip duration change. This choice of labeling may not be optimum and may later be changed to another measure. With this choice higher bandwidth systems, using a higher chip rate, would be required to achieve higher precision timing measurements. This would assure the higher accuracy inherent in wider band signals, but may also be more technically challenging.]

8.1 UE (mobile station)

8.1.1 Support for OTDOA measurement

The UE shall be able to measure (and report) the observed time difference of the (downlink) synchronization signals from as many base stations as it can receive in the active or idle state. These measurements shall be reported to the highest resolution possible. A resolution of [1/8 chip duration] is suggested as a design goal. The minimum resolution shall be [1/4 chip duration]. It is likely that various UE will have different capability of measurement resolution. These may range from one or more chip times to small fractions of chip times and shall be indicated to the LCS process by appropriate class marks and signalling. It should be noted that multi-path propagation will affect the OTDOA measurement and signal processing techniques involving multiple or repeated measurements may be beneficial to achieve the needed practical resolution. These techniques are FFS.

These measurements shall be made for all signals received down to the sensitivity limit of the receiver¹⁷. As the signals from various base stations will be received at (markedly) different signal levels, the UE shall also report the signal strength of each measurement so that the calculation function may, if it so chooses, apply more weight to the measurements of the stronger signals.

The UE shall also be able to report the time-of-day the OTDOA measurements were made. [The frame number may be a convenient means of denoting time for these measurements. Note that if the UE is unable to return the time-of-day of its measurements, the positioning signal measurement function may use the average of the time the request was sent and the time measurements are returned (half way in-between) as an indication of the time-of-day the measurements were actually made.]

¹⁷ It may not be necessary to measure quite all the received signals. At least the three strongest should be measured, together with as many others as may provide reliable measurements.

A number of other detailed parameters of the OTDOA measurement must also be specified. These are FFS. The nature of the measurements and their timing in the three operating environments, (vehicular, outdoor pedestrian and indoor) are FFS. There may also be differences between the TDD and FDD modes of operation that are FFS.

8.1.2 Support for RTT measurement

In order to support the use of the RTT measurement to assist the location service, the UE shall provide a resolution of [1/4 chip] time, or less, in the measurement and timing of its transmissions. The jitter in the upstream transmission timing for shall also be less than this value. If the UE is capable of better resolution (e.g. 1/4, 1/8 1/10 chip duration) this capability shall be indicated to the LCS process by means of a class mark and signalling.

A number of other detailed parameters to support the RTT measurement must also be specified. These are FFS.

8.2 Node-B (base station)

8.2.1 RTT Measurement

The node-B shall be capable of measuring the round trip delay (or 1/2 that for one way delay (OWD) for its active UE. The accuracy of this measurement depends on the combination of the resolution of the measurement at the Node-B and the resolution in transmission at the UE. The Node-B shall be capable of a resolution of measurement of less than [1/2 chip duration]. Various Node-B may be capable of better resolution (e.g. 1/4, 1/8 1/10 chip duration) and this capability shall be indicated to the LCS process by the node-b through a class mark and signalling.

A number of other detailed parameters to support the RTT measurement must also be specified. These are FFS.

8.2.2 Frequency offset

In order to constrain the rate at which the RTD drifts between unsynchronised base stations, the maximum frequency difference between base stations involved in the LCS shall be limited to less than [$\pm 10^{-9}$] [Other considerations may constrain the frequency difference to a smaller range than this.] The frequency stability of each Node-B shall be denoted by a class mark and made available to the LCS process through signalling.

A number of other detailed parameters for the frequency offset must also be specified. These are FFS.

8.2.3 Survey location

The geographic location of the Node-B transmit antenna radiating centre shall be surveyed to an accuracy of better than [± 3 metres] in horizontal and vertical directions. This represents a timing uncertainty of [± 10] nanoseconds.

These coordinates shall be made available to the database and the calculating functions. More accurate coordinates may also be made available. The improved accuracy shall be indicated to the LCS process by means of a class mark and signalling.

If the base station is making use of diversity transmissions, the coordinates of each antenna radiating centre shall be measured and made available to the database and the calculation functions. The calculation function may use the time of measurement of the downlink signals to determine which antenna location was used.

8.3 Relative Time Difference (RTD)

To achieve the desired accuracy in the location estimates, the RTD needs to be known to (at least) the same level of accuracy as the OTDOA measurements. Whether the downlink transmissions are synchronised or their time offset measured, the timing offsets shall be reported to the highest resolution available. A resolution of [$1/8$ chip duration] is suggested as a design goal. The minimum resolution shall be [$1/4$ chip duration]. It is likely that various node-B will have different capability of measurement resolution. These may range from one or more chip times to small fractions of chip times and shall be indicated to the LCS process by appropriate class marks and signalling.

If the timing of transmissions at the base stations is synchronised, so that the RTD is maintained approximately constant, the maximum jitter in the transmission timing shall not exceed [$1/8$ chip duration].

The RTD measurement shall also be able to report the time-of-day the measurements were made. [The frame number may be a convenient means of denoting time for these measurements.]

8.4 Error budgets

This section provides a guide to the allowed errors in measurements in order to achieve the desired level of location accuracy for the LCS technique. This topic is FFS.

9 Signalling requirements

9.1 UTRAN - UE

9.1.1 OTDOA

There are two modes of operation for the OTDOA method. In the *UE assisted* mode, the UE measures the difference in time of arrival of several cells and signals the measurement results to the network, where a network element (the Positioning Calculation Function (PCF)) carries out the location calculation. In the *UE based* mode, the UE makes the measurements and also carries out the location calculation, and thus requires additional information (such as the location of the measured base stations) that is required for the location calculation. This information is provided by the Location System Information Function (LSIF).

Table 1 lists the required information for both OTDOA modes. The range of values for the listed parameters are FFS. The required information can be signalled to the UE either in a broadcast channel or partly also as dedicated signalling.

Table 1. Information required for UE assisted and UE based OTDOA in the UTRAN (LSIF) to UE direction ('Yes' = information required, 'No' = Information not required)

Information	UE assisted OTDOA	UE based OTDOA
Intra frequency Cell Info (neighbour list).	Yes	Yes
¹⁸ Ciphering information for LCS	No	Yes
Measurement control information (idle period locations)	Yes	Yes
Sectorization of the neighboring cells	No	Yes
Measured RTD values for Cells mentioned at Intra frequency Cell Info	No	Yes
RTD accuracy	No	Yes
Measured roundtrip delay for primary serving cell	No	Yes
Geographical location of the primary serving cell.	No	Yes
Relative neighbor cell geographical location	No	Yes
Accuracy range of the geographical location values	No	Yes

¹⁸ The idea behind LCS specific ciphering information is e.g. that the operator can sell information that the UE needs for calculating its location. For reference in the GSM world see [3].

The information required from UE to UTRAN (PSMF/PCF) is listed in Table 2.

Table 2. Information required for UE assisted and UE based OTDOA in the UE to UTRAN (PSMF/PCF) direction

Information	UE assisted OTDOA	UE based OTDOA
OTDOA measurement results	Yes	No
OTDOA measurement accuracy	Yes	No
UE geographical location	No	Yes
Location accuracy indicator (based on the signalled and measurement accuracies)	No	Yes

9.1.2 Navigation System Assisted

These methods make use of UE which are equipped with radio receivers capable of receiving signals from navigation systems such as the Global Positioning System (GPS).

9.1.2.1 Network Assisted, UE Based (GPS)

In this method, the UE includes a GPS receiver which is capable of measuring and calculating the UE location based on the GPS signals. The operation of this receiver is assisted by information supplied by the UTRAN (LSIF). The GPS acquisition and location calculation is assisted by the following information that is signalled from the UTRAN (LSIF) to the UE:

- Number of satellites for which assistance is provided
- Reference time for GPS
- Reference location
- Ionospheric corrections
- Satellite ID for identifying the satellites for which the assistance is provided
- IODE: sequence number for the ephemeris for the particular satellite
- Ephemeris to accurately model the orbit of the particular satellite and information when this becomes valid
- Clock corrections
- DGPS corrections

The location information message from UE to the UTRAN (PSMF/PCF) contains the location calculated based on GPS measurements. The message contains the following information:

- Reference time for which the computed position is valid
- Serving cell information
- Latitude/Longitude/Altitude/Error ellipse
- Velocity estimate of the UE
- Satellite ID for which the measurement data is valid
- Whole/Fractional chips for information about the code-phase measurements

C/N₀ of the received signal from the particular satellite used in the measurements.
 Doppler frequency measured by the UE for the particular satellite signal
 Pseudorange RMS error
 Multipath indicator

9.1.2.2 Network Based, UE Assisted (GPS)

In this method, the UE includes a GPS receiver which is capable of measuring the GPS signals. The operation of this receiver is assisted by information supplied by the UTRAN (LSIF). The GPS measurements are signalled to the UTRAN (PSMF/PCF) where the Positioning Calculation Function determines the UE location. The GPS acquisition is assisted by the following information that is signalled from the UTRAN (LSIF) to the UE :

- Number of Satellites
- Reference Time for GPS
- SVID/PRNID
- Doppler (0th order term)
- Doppler (1st order term) (optional)
- Doppler Uncertainty (optional)
- Code Phase
- Integer Code Phase
- GPS Bit Number
- Code Phase Search Window
- Azimuth
- Elevation

The GPS measurement message from UE to the UTRAN (PSMF/PCF) contains the following information measured from the GPS :

- Number of Pseudoranges
- Reference Time for GPS
- SVID/PRNID
- Satellite C/No
- Doppler
- Satellite Code Phase – Whole Chips
- Satellite Code Phase – Fractional Chips
- Multipath Indicator
- Pseudorange RMS Error

9.1.3 Other methods

[FFS]

9.2 UTRAN – Node-B/LMU

9.2.1 Round Trip Time (RTT)

This method makes use of measurements by the Node-B or LMU of the round trip time for transmissions to and from the UE. The RTT measurement message from Node-B or LMU to the UTRAN (PSMF/PCF) contains the following information :

- Round trip time (in fractional chips)
- Time of measurement
- Received sector
- Doppler of received signal (Hz)
- Multipath Indicator

10

10

¹⁹ In GSM 03.71 this entity is described in the system handling component part of functional model.

²⁰ In this approach mobile station may use the GPS positioning mechanism but still demand e.g. auxiliary measurements from the serving network.

10History

Change history					
TR 25.923	V1.0.0		Noted by TSG-RAN		
	V1.1.0		Include ontributions from WG2#5	August 13	editor