

Agenda Item:

Source: Rapporteur

Title: 25.331, RRC Protocol Specification, V1.2.0

Document for: Approval

Attached is the RRC protocol specification which includes changes agreed at the last RAN WG2 meeting (July 5-9, 1999).

A number of minor edits have also been made for clarification and consistency, of particular note:

1) The title of section 15.1.4 has been changed

from: Intra-frequency reporting mechanisms

to: Mechanisms available for modifying intra-frequency measurement reporting behaviour

2) The list of RRC functions (Section 7) has been updated to be consistent with those described in 25.301

3) The text in section 4 has been edited to bring it into line with the corresponding diagrams (ie. BCFE and PNFE can use both Tr-SAP and UM-SAP).

**3rd Generation Partnership Project (3GPP);
Technical Specification Group (TSG) RAN;
Working Group 2 (WG2);**

RRC Protocol Specification



The present document has been developed within the 3rd Generation Partnership Project (3GPPTM) and may be further elaborated for the purposes of 3GPP.

The present document has not been subject to any approval process by the 3GPP Organisational Partners and shall not be implemented.

This Specification is provided for future development work within 3GPP only. The Organisational Partners accept no liability for any use of this Specification.

Specifications and reports for implementation of the 3GPPTM system should be obtained via the 3GPP Organisational Partners' Publications Offices.

Reference

<Workitem> (<Shortfilename>.PDF)

Keywords

<keyword[, keyword]>

3GPP

Postal address

Office address

Internet

secretariat@3gpp.org
Individual copies of this deliverable
can be downloaded from
<http://www.3gpp.org>

Copyright Notification

No part may be reproduced except as authorized by written permission.
The copyright and the foregoing restriction extend to reproduction in all media.

©
All rights reserved.

Contents

1. SCOPE	18
2. REFERENCES	18
3. DEFINITIONS, SYMBOLS AND ABBREVIATIONS	18
3.1 DEFINITIONS	18
3.2 ABBREVIATIONS	18
4. GENERAL	20
5 RRC SERVICES PROVIDED TO UPPER LAYERS	22
6 SERVICES EXPECTED FROM LOWER LAYERS	22
6.1 SERVICES EXPECTED FROM LAYER 2	22
6.2 SERVICES EXPECTED FROM LAYER 1	22
7 FUNCTIONS OF RRC	22
8 ELEMENTARY RRC PROCEDURES	23
8.1 IDLE MODE PROCEDURES	23
8.1.1 Broadcast of system information.....	23
8.1.2 Paging.....	25
8.1.3 Notification	25
8.2 RRC CONNECTION ESTABLISHMENT AND RELEASE PROCEDURES	25
8.2.1 RRC Connection Establishment.....	25
8.2.2 RRC Connection Release	27
8.2.3 RRC Connection re-establishment	28
8.3 RRC CONNECTED MODE PROCEDURES	28
8.3.1 Radio Access Bearer Related Procedures.....	28
8.3.1.1 Radio Access Bearer Establishment	28
8.3.1.2 Radio Access Bearer Release.....	29
8.3.1.3 Radio Access Bearer and signalling link Reconfiguration.....	30
8.3.2 Transport Channel Reconfiguration	30
8.3.3 Transport Format Combination Control	31
8.3.4 Physical Channel Reconfiguration	32
8.3.5 Mobility Related Procedures	32
8.3.5.1 Modification of the active set when in Soft hand-over	32
8.3.5.2 Hard handover (FDD and TDD hard).....	33
8.3.5.3 Inter system hard hand-over (GSM/BSS to UTRAN).....	33
8.3.5.4 Inter system hard hand-over (UTRAN to GSM/BSS, PSTN/ISDN domain services).....	34
8.3.5.5 Inter system cell reselection (UTRAN to GSM/GPRS, IP domain services).....	35
8.3.5.6 Inter system cell reselection (GSM/GPRS to UTRAN, IP domain services).....	35
8.3.5.7 URA update.....	35
8.3.5.8 Cell update.....	36
8.3.5.9 RNTI reallocation	36
8.3.6 RRC Connected mode procedures which use Paging	37
8.3.6.1 Core network originated paging	37
8.3.6.2 UTRAN originated paging.....	37
8.3.7 Procedures related to measurement and monitoring.....	38
8.3.7.1 Measurement control	39
8.3.7.2 Measurement reporting.....	40
8.3.8 Other procedures in connected mode	41
8.3.8.1 Transmission of UE capability information	41
8.3.8.2 Sending of system information in RRC connected mode	41
8.3.8.3 Direct transfer.....	42
8.3.8.4 RRC status procedure	43
8.3.8.5 UE Capability Enquiry	43
9 PRIMITIVES BETWEEN RRC AND UPPER LAYERS	44

10	MESSAGE AND INFORMATION ELEMENT FUNCTIONAL DEFINITION AND CONTENT	44
10.1	RADIO RESOURCE CONTROL MESSAGES	44
10.1.1	<i>RRC Connection Mobility Messages</i>	44
10.1.1.1	ACTIVE SET UPDATE	44
10.1.1.2	ACTIVE SET UPDATE COMPLETE.....	44
10.1.1.3	CELL UPDATE	45
10.1.1.4	CELL UPDATE CONFIRM	45
10.1.1.5	HANDOVER COMMAND	46
10.1.1.6	HANDOVER COMPLETE	46
10.1.1.7	INTER-SYSTEM HANDOVER COMMAND.....	47
10.1.1.8	INTER-SYSTEM HANDOVER FAILURE	47
10.1.1.9	URA UPDATE.....	47
10.1.1.10	URA UPDATE CONFIRM.....	48
10.1.1.11	RNTI REALLOCATION	48
10.1.1.12	RNTI REALLOCATION COMPLETE	49
10.1.2	<i>Measurement Messages</i>	49
10.1.2.1	MEASUREMENT CONTROL	49
10.1.2.2	MEASUREMENT REPORT	51
10.1.3	<i>Paging and Notification Messages</i>	52
10.1.3.1	NOTIFICATION.....	52
10.1.3.2	PAGING TYPE 1.....	52
10.1.3.3	PAGING TYPE 2.....	52
10.1.4	<i>RRC Connection Establishment and maintenance messages</i>	53
10.1.4.1	RRC CONNECTION RE-ESTABLISHMENT	53
10.1.4.2	RRC CONNECTION RE-ESTABLISHMENT COMPLETE	53
10.1.4.3	RRC CONNECTION RE-ESTABLISHMENT REQUEST	53
10.1.4.4	RRC CONNECTION RELEASE.....	54
10.1.4.5	RRC CONNECTION RELEASE COMPLETE.....	54
10.1.4.6	RRC CONNECTION REQUEST	54
10.1.4.7	RRC CONNECTION SETUP.....	55
10.1.4.8	RRC CONNECTION SETUP COMPLETE.....	56
10.1.4.9	RRC CONNECTION REJECT	57
10.1.4.10	RRC STATUS.....	57
10.1.4.11	RRC STATUS ACK	57
10.1.5	<i>Radio Access Bearer control messages</i>	58
10.1.5.1	PHYSICAL CHANNEL RECONFIGURATION	58
10.1.5.2	PHYSICAL CHANNEL RECONFIGURATION COMPLETE	58
10.1.5.3	RADIO ACCESS BEARER RECONFIGURATION	59
10.1.5.4	RADIO ACCESS BEARER RECONFIGURATION COMPLETE	60
10.1.5.5	RADIO ACCESS BEARER RELEASE	61
10.1.5.6	RADIO ACCESS BEARER RELEASE COMPLETE	63
10.1.5.7	RADIO ACCESS BEARER SETUP	63
10.1.5.8	RADIO ACCESS BEARER SETUP COMPLETE.....	65
10.1.5.9	TRANSPORT CHANNEL RECONFIGURATION	65
10.1.5.10	TRANSPORT CHANNEL RECONFIGURATION COMPLETE.....	66
10.1.5.11	TRANSPORT FORMAT COMBINATION CONTROL.....	67
10.1.6	<i>System Information Messages</i>	67
10.1.6.1	SYSTEM INFORMATION	67
10.1.7	<i>Other Messages</i>	69
10.1.7.1	UE CAPABILITY INFORMATION	69
10.1.7.2	UE CAPABILITY INFORMATION CONFIRM	70
10.1.7.3	DIRECT TRANSFER	70
10.2	INFORMATION ELEMENT FUNCTIONAL DEFINITIONS	71
10.2.1	<i>CN Information elements</i>	71
10.2.1.1	CN domain identity	71
10.2.1.2	NAS binding info	71
10.2.1.3	NAS message	71
10.2.1.4	NAS system information	71
10.2.1.5	PLMN identity	71
10.2.2	<i>UTRAN mobility Information elements</i>	71
10.2.2.1	Cell identity.....	71
10.2.2.2	Cell selection and re-selection info	71
10.2.2.3	Information for periodic cell and URA update.....	71
10.2.2.4	URA identity	71
10.2.2.5	URA update indicator	72

<i>10.2.3 UE Information elements</i>	72
10.2.3.1 Uplink access control info	72
10.2.3.2 C-RNTI	72
10.2.3.3 S-RNTI	72
10.2.3.4 SRNC identity	72
10.2.3.5 Initial UE identity	72
10.2.3.6 Activation time	72
10.2.3.7 Wait time	72
10.2.3.8 Control-only-state timer	73
10.2.3.9 Paging record	73
10.2.3.10 Establishment cause	73
10.2.3.11 Release cause	73
10.2.3.12 Rejection cause	73
10.2.3.13 Paging cause	73
10.2.3.14 Initial UE capability	73
10.2.3.15 Power control capability	73
10.2.3.16 Code resource capability	73
10.2.3.17 UE mode capability	73
10.2.3.18 Transport channel support capability	74
10.2.3.19 Ciphering capability	74
10.2.3.20 Macro diversity capability	74
10.2.3.21 Cell update cause	74
10.2.3.22 URA update cause	74
10.2.3.23 Number of Quick Repeat	74
10.2.3.24 Inter-system handover failure cause	74
10.2.3.25 Transmission probability	74
10.2.3.26 Maximum bit rate	75
10.2.3.27 Capability Update Requirement	75
<i>10.2.4 Radio Access Bearer Information elements</i>	75
10.2.4.1 RAB identity	75
10.2.4.2 RLC info	75
10.2.4.3 Signalling link type	76
10.2.4.4 RAB multiplexing info	76
<i>10.2.5 Transport CH Information elements</i>	76
10.2.5.1 Transport Format Combination Set	76
10.2.5.2 Transport Format Combination Subset	76
10.2.5.3 Transport channel identity	76
10.2.5.4 Transport Format Set (TFS)	76
10.2.5.5 Dynamic Control	77
10.2.5.6 Transmission time validity	77
10.2.5.7 Time duration before retry	77
10.2.5.8 Silent period duration before release	77
<i>10.2.6 Physical CH Information elements</i>	77
10.2.6.1 Frequency info	77
10.2.6.2 Primary CCPCH info	77
10.2.6.3 Secondary CCPCH info	77
10.2.6.4 PRACH info	77
10.2.6.6 Uplink DPCH info	78
10.2.6.7 Uplink DPCH power control info	78
10.2.6.8 Downlink DPCH info	78
10.2.6.9 Uplink timeslot info	79
10.2.6.10 Downlink timeslot info	79
10.2.6.11 SSdT indicator	79
10.2.6.12 SSdT cell identity	79
10.2.6.13 Gated Transmission Control info (FFS)	79
10.2.6.14 Default DPCH Offset Value	79
<i>10.2.7 Measurement Information elements</i>	80
10.2.7.1 Measurement Identity Number	80
10.2.7.2 Measurement Command	80
10.2.7.3 Measurement Type	80
10.2.7.4 Reference time difference to cell	80
10.2.7.5 Measured time difference to cell	80
10.2.7.6 Measurement reporting mode	81
10.2.7.7 Intra-frequency cell info	81
10.2.7.8 Inter-frequency cell info	81
10.2.7.9 Inter-system cell info	81
10.2.7.10 Traffic volume measurement object	81

10.2.7.11 Quality measurement object (FFS).....	81
10.2.7.12 Intra-frequency measurement quantity	82
10.2.7.13 Inter-frequency measurement quantity (FFS).....	82
10.2.7.14 Inter-system measurement quantity (FFS).....	82
10.2.7.15 Traffic volume measurement quantity	82
10.2.7.16 UE internal measurement quantity	82
10.2.7.17 Quality measurement quantity (FFS)	83
10.2.7.18 Intra-frequency reporting quantity	83
10.2.7.19 Intra-frequency reporting quantity for RACH reporting	83
10.2.7.20 Inter-frequency reporting quantity (FFS)	83
10.2.7.21 Inter-system reporting quantity (FFS).....	84
10.2.7.22 Traffic volume reporting quantity	84
10.2.7.23 Quality reporting quantity (FFS).....	84
10.2.7.25 Inter-frequency measurement reporting criteria (FFS).....	85
10.2.7.26 Inter-system measurement reporting criteria (FFS).....	85
10.2.7.27 Traffic volume measurement reporting criteria	85
10.2.7.28 Quality measurement reporting criteria (FFS).....	86
10.2.7.29 UE internal measurement reporting criteria	86
10.2.7.30 Periodical reporting criteria.....	86
10.2.7.31 Intra-frequency measurement event results	87
10.2.7.32 Inter-frequency measurement event results (FFS).....	87
10.2.7.33 Inter-system measurement event results (FFS).....	87
10.2.7.34 Traffic volume measurement event results	87
10.2.7.35 Quality measurement event results (FFS).....	87
10.2.7.36 Measured results	87
10.2.7.37 SFN Measurement Indicator	88
<i>10.2.8 Other Information elements</i>	<i>88</i>
10.2.8.1 BCCH modification info	88
10.2.8.2 Inter-system message.....	88
11 MESSAGE AND INFORMATION ELEMENT ABSTRACT SYNTAX (WITH ASN.1)	89
12 MESSAGE TRANSFER SYNTAX	90
13 PROTOCOL STATES	90
14 PROTOCOL TIMERS, COUNTERS AND OTHER PARAMETERS	90
15 SPECIFIC FUNCTIONS	90
15.1 INTRA-FREQUENCY MEASUREMENTS	90
15.1.1 Intra-frequency measurement quantities	90
15.1.2 Intra-frequency reporting events	90
15.1.2.1 Reporting event 1A: A Primary CCPCH enters the reporting range	90
15.1.2.2 Reporting event 1B: A primary CCPCH leaves the reporting range	91
15.1.2.3 Reporting event 1C: A non-active primary CCPCH becomes better than an active primary CCPCH	92
15.1.2.4 Reporting event 1D: Change of best cell.....	92
15.1.2.5 Reporting event 1E: A Primary CCPCH becomes better than an absolute threshold.....	93
15.1.2.6 Reporting event 1F: A Primary CCPCH becomes worse than an absolute threshold	94
15.1.3 Event-triggered periodic intra-frequency measurement reports.....	94
15.1.3.1 Cell addition failure	94
15.1.3.2 Cell replacement failure	95
15.1.4 Mechanisms available for modifying intra-frequency measurement reporting behaviour	95
15.1.4.1 Hysteresis	95
15.1.4.2 Time-to-trigger	96
15.1.4.3 Cell individual offsets	97
15.1.4.4 Forbid a Primary CCPCH to affect the reporting range	97
15.1.5 Report quantities.....	98
15.2 TRAFFIC VOLUME MEASUREMENTS	98
15.2.1 Traffic Volume Measurement Quantity.....	98
15.2.2 Traffic Volume reporting events	99
15.2.3 Traffic volume reporting mechanisms.....	99
15.3 UE INTERNAL MEASUREMENTS.....	100
15.3.1 UE internal measurement quantities.....	100
15.3.2 UE internal measurement reporting events	100

15.3.2.1	Reporting event 6A: The UE Tx power becomes larger than an absolute threshold	100
15.3.2.2	Reporting event 6B: The UE Tx power becomes less than an absolute threshold.....	100
15.3.2.3	Reporting event 6C: The UE Tx power reaches its minimum value.....	101
15.3.2.4	Reporting event 6D: The UE Tx power reaches its maximum value.....	101
15.3.2.5	Reporting event 6E: The UE RSSI reaches the UE's dynamic receiver range	102
15.4	DYNAMIC RESOURCE ALLOCATION CONTROL OF UPLINK DCH	102
16	HANDLING OF UNKNOWN, UNFORESEEN AND ERRONEOUS PROTOCOL DATA.....	103
17	SDL	103
18	APPENDICES: EXAMPLES OF OPERATION	103
19	HISTORY	104
1.	SCOPE.....	13
2.	REFERENCES.....	13
3.	DEFINITIONS, SYMBOLS AND ABBREVIATIONS.....	13
3.1	DEFINITIONS	13
3.2	ABBREVIATIONS	13
4.	GENERAL.....	15
5.	RRC SERVICES PROVIDED TO UPPER LAYERS.....	17
6.	SERVICES EXPECTED FROM LOWER LAYERS.....	17
6.1	SERVICES EXPECTED FROM LAYER 2	17
6.2	SERVICES EXPECTED FROM LAYER 1	17
7.	FUNCTIONS OF RRC.....	17
8.	ELEMENTARY RRC PROCEDURES.....	18
8.1	IDLE MODE PROCEDURES	18
8.1.1	Broadcast of system information.....	18
8.1.2	Paging.....	20
8.1.3	Notification	20
8.2	RRC CONNECTION ESTABLISHMENT AND RELEASE PROCEDURES	20
8.2.1	RRC Connection Establishment.....	20
8.2.2	RRC Connection Release	22
8.2.3	RRC Connection re-establishment.....	23
8.3	RRC CONNECTED MODE PROCEDURES	23
8.3.1	Radio Access Bearer Related Procedures.....	23
8.3.1.1	Radio Access Bearer Establishment	23
8.3.1.2	Radio Access Bearer Release.....	24
8.3.1.3	Radio Access Bearer and signalling link Reconfiguration.....	25
8.3.2	Transport Channel Reconfiguration.....	25
8.3.3	Transport Format Combination Control	26
8.3.4	Dynamic Resource Allocation Control of Uplink DCH.....	27
8.3.5	Physical Channel Reconfiguration	27
8.3.6	Mobility Related Procedures	28
8.3.6.1	Modification of the active set when in Soft hand over	28
8.3.6.2	Hard handover (FDD and TDD hard).....	29
8.3.6.3	Inter system hard hand over (GSM/BSS to UTRAN).....	29
8.3.6.4	Inter system hard hand over (UTRAN to GSM/BSS, PSTN/ISDN domain services).....	30
8.3.6.5	Inter system cell reselection (UTRAN to GSM/GPRS, IP domain services).....	31
8.3.6.6	Inter system cell reselection (GSM/GPRS to UTRAN, IP domain services).....	31
8.3.6.7	URA update.....	31
8.3.6.8	Cell update.....	32
8.3.6.9	RNTI reallocation.....	32
8.3.7	RRC Connected mode procedures which use Paging.....	33

8.3.7.1	Core network originated paging	33
8.3.7.2	UTRAN originated paging	33
8.3.8	<i>Procedures related to measurement and monitoring</i>	34
8.3.8.1	Measurement control	35
8.3.8.2	Measurement reporting	36
8.3.9	<i>Other procedures in connected mode</i>	36
8.3.9.1	Transmission of UE capability information	36
8.3.9.2	Sending of system information in RRC connected mode	37
8.3.9.3	Direct transfer	38
8.3.9.4	RRC status procedure	38
8.3.9.5	UE Capability Enquiry	39
9	PRIMITIVES BETWEEN RRC AND UPPER LAYERS	39
10	MESSAGE AND INFORMATION ELEMENT FUNCTIONAL DEFINITION AND CONTENT	40
10.1	RADIO RESOURCE CONTROL MESSAGES	40
10.1.1	<i>RRC Connection Mobility Messages</i>	40
10.1.1.1	ACTIVE SET UPDATE	40
10.1.1.2	ACTIVE SET UPDATE COMPLETE	40
10.1.1.3	CELL UPDATE	41
10.1.1.4	CELL UPDATE CONFIRM	41
10.1.1.5	HANDOVER COMMAND	42
10.1.1.6	HANDOVER COMPLETE	42
10.1.1.7	INTER SYSTEM HANDOVER COMMAND	43
10.1.1.8	INTER SYSTEM HANDOVER FAILURE	43
10.1.1.9	URA UPDATE	43
10.1.1.10	URA UPDATE CONFIRM	44
10.1.1.11	RNTI REALLOCATION	44
10.1.1.12	RNTI REALLOCATION COMPLETE	45
10.1.2	<i>Measurement Messages</i>	45
10.1.2.1	MEASUREMENT CONTROL	45
10.1.2.2	MEASUREMENT REPORT	47
10.1.3	<i>Paging and Notification Messages</i>	48
10.1.3.1	NOTIFICATION	48
10.1.3.2	PAGING TYPE 1	48
10.1.3.3	PAGING TYPE 2	48
10.1.4	<i>RRC Connection Establishment and maintenance messages</i>	49
10.1.4.1	RRC CONNECTION RE ESTABLISHMENT	49
10.1.4.2	RRC CONNECTION RE ESTABLISHMENT COMPLETE	49
10.1.4.3	RRC CONNECTION RE ESTABLISHMENT REQUEST	49
10.1.4.4	RRC CONNECTION RELEASE	50
10.1.4.5	RRC CONNECTION RELEASE COMPLETE	50
10.1.4.6	RRC CONNECTION REQUEST	50
10.1.4.7	RRC CONNECTION SETUP	51
10.1.4.8	RRC CONNECTION SETUP COMPLETE	52
10.1.4.9	RRC CONNECTION REJECT	53
10.1.4.10	RRC STATUS	53
10.1.4.11	RRC STATUS ACK	53
10.1.5	<i>Radio Access Bearer control messages</i>	54
10.1.5.1	PHYSICAL CHANNEL RECONFIGURATION	54
10.1.5.2	PHYSICAL CHANNEL RECONFIGURATION COMPLETE	54
10.1.5.3	RADIO ACCESS BEARER RECONFIGURATION	55
10.1.5.4	RADIO ACCESS BEARER RECONFIGURATION COMPLETE	56
10.1.5.5	RADIO ACCESS BEARER RELEASE	57
10.1.5.6	RADIO ACCESS BEARER RELEASE COMPLETE	59
10.1.5.7	RADIO ACCESS BEARER SETUP	59
10.1.5.8	RADIO ACCESS BEARER SETUP COMPLETE	61
10.1.5.9	TRANSPORT CHANNEL RECONFIGURATION	61
10.1.5.10	TRANSPORT CHANNEL RECONFIGURATION COMPLETE	62
10.1.5.11	TRANSPORT FORMAT COMBINATION CONTROL	63
10.1.6	<i>System Information Messages</i>	63
10.1.6.1	SYSTEM INFORMATION	63
10.1.7	<i>Other Messages</i>	65
10.1.7.1	UE CAPABILITY INFORMATION	65
10.1.7.2	UE CAPABILITY INFORMATION CONFIRM	66
10.1.7.3	DIRECT TRANSFER	66

10.2 INFORMATION ELEMENT FUNCTIONAL DEFINITIONS	67
10.2.1 CN Information elements	67
10.2.1.1 CN domain identity	67
10.2.1.2 NAS binding info	67
10.2.1.3 NAS message	67
10.2.1.4 NAS system information	67
10.2.1.5 PLMN identity	67
10.2.2 UTRAN mobility Information elements	67
10.2.2.1 Cell identity	67
10.2.2.2 Cell selection and re-selection info	67
10.2.2.3 Information for periodic cell and URA update	67
10.2.2.4 URA identity	67
10.2.2.5 URA update indicator	68
10.2.3 UE Information elements	68
10.2.3.1 Uplink access control info	68
10.2.3.2 C-RNTI	68
10.2.3.3 S-RNTI	68
10.2.3.4 SRNC identity	68
10.2.3.5 Initial UE identity	68
10.2.3.6 Activation time	68
10.2.3.7 Wait time	68
10.2.3.8 Control only state timer	69
10.2.3.9 Paging record	69
10.2.3.10 Establishment cause	69
10.2.3.11 Release cause	69
10.2.3.12 Rejection cause	69
10.2.3.13 Paging cause	69
10.2.3.14 Initial UE capability	69
10.2.3.15 Power control capability	69
10.2.3.16 Code resource capability	69
10.2.3.17 UE mode capability	69
10.2.3.18 Transport channel support capability	70
10.2.3.19 Ciphering capability	70
10.2.3.20 Macro diversity capability	70
10.2.3.21 Cell update cause	70
10.2.3.22 URA update cause	70
10.2.3.23 Number of Quick Repeat	70
10.2.3.24 Inter-system handover failure cause	70
10.2.3.25 Transmission probability	70
10.2.3.26 Maximum bit rate	71
10.2.3.27 Capability Update Requirement	71
10.2.4 Radio Access Bearer Information elements	71
10.2.4.1 RAB identity	71
10.2.4.2 RLC info	71
10.2.4.3 Signalling link type	72
10.2.4.4 RAB multiplexing info	72
10.2.5 Transport CH Information elements	72
10.2.5.1 Transport Format Combination Set	72
10.2.5.2 Transport Format Combination Subset	72
10.2.5.3 Transport channel identity	72
10.2.5.4 Transport Format Set (TFS)	72
10.2.5.5 Dynamic Control	73
10.2.5.6 Transmission time validity	73
10.2.5.7 Time duration before retry	73
10.2.5.8 Silent period duration before release	73
10.2.6 Physical CH Information elements	73
10.2.6.1 Frequency info	73
10.2.6.2 Primary CCPCH info	73
10.2.6.3 Secondary CCPCH info	73
10.2.6.4 PRACH info	73
10.2.6.6 Uplink DPCH info	74
10.2.6.7 Uplink DPCH power control info	74
10.2.6.8 Downlink DPCH info	74
10.2.6.9 Uplink timeslot info	75
10.2.6.10 Downlink timeslot info	75
10.2.6.11 SS DT indicator	75

10.2.6.12 SSSDT cell identity	75
10.2.6.13 Gated Transmission Control info (FFS)	75
10.2.6.14 Default DPCH Offset Value	75
10.2.7 Measurement Information elements	76
10.2.7.1 Measurement Identity Number	76
10.2.7.2 Measurement Command	76
10.2.7.3 Measurement Type	76
10.2.7.4 Reference time difference to cell	76
10.2.7.5 Measured time difference to cell	76
10.2.7.6 Measurement reporting mode	77
10.2.7.7 Intra frequency cell info	77
10.2.7.8 Inter frequency cell info	77
10.2.7.9 Inter system cell info	77
10.2.7.10 Traffic volume measurement object	77
10.2.7.11 Quality measurement object (FFS)	77
10.2.7.12 Intra frequency measurement quantity	78
10.2.7.13 Inter frequency measurement quantity (FFS)	78
10.2.7.14 Inter system measurement quantity (FFS)	78
10.2.7.15 Traffic volume measurement quantity	78
10.2.7.16 UE internal measurement quantity	78
10.2.7.17 Quality measurement quantity (FFS)	79
10.2.7.18 Intra frequency reporting quantity	79
10.2.7.19 Intra frequency reporting quantity for RACH reporting	79
10.2.7.20 Inter frequency reporting quantity (FFS)	79
10.2.7.21 Inter system reporting quantity (FFS)	80
10.2.7.22 Traffic volume reporting quantity	80
10.2.7.23 Quality reporting quantity (FFS)	80
10.2.7.25 Inter frequency measurement reporting criteria (FFS)	81
10.2.7.26 Inter system measurement reporting criteria (FFS)	81
10.2.7.27 Traffic volume measurement reporting criteria	81
10.2.7.28 Quality measurement reporting criteria (FFS)	82
10.2.7.29 UE internal measurement reporting criteria	82
10.2.7.30 Periodical reporting criteria	82
10.2.7.31 Intra frequency measurement event results	83
10.2.7.32 Inter frequency measurement event results (FFS)	83
10.2.7.33 Inter system measurement event results (FFS)	83
10.2.7.34 Traffic volume measurement event results	83
10.2.7.35 Quality measurement event results (FFS)	83
10.2.7.36 Measured results	83
10.2.7.37 SFN Measurement Indicator	84
10.2.8 Other Information elements	84
10.2.8.1 BCCCH modification info	84
10.2.8.2 Inter system message	84
11 MESSAGE AND INFORMATION ELEMENT ABSTRACT SYNTAX (WITH ASN.1)	85
12 MESSAGE TRANSFER SYNTAX	86
13 PROTOCOL STATES	86
14 PROTOCOL TIMERS, COUNTERS AND OTHER PARAMETERS	86
15 SPECIFIC FUNCTIONS	86
15.1 INTRA FREQUENCY MEASUREMENTS	86
15.1.1 Intra frequency measurement quantities	86
15.1.2 Intra frequency reporting events	86
15.1.2.1 Reporting event 1A: A Primary CCPCH enters the reporting range	86
15.1.2.2 Reporting event 1B: A primary CCPCH leaves the reporting range	86
15.1.2.3 Reporting event 1C: A non active primary CCPCH becomes better than an active primary CCPCH	88
15.1.2.4 Reporting event 1D: Change of best cell	88
15.1.2.5 Reporting event 1E: A Primary CCPCH becomes better than an absolute threshold	89
15.1.2.6 Reporting event 1F: A Primary CCPCH becomes worse than an absolute threshold	90
15.1.3 Event triggered periodic intra frequency measurement reports	90
15.1.3.1 Cell addition failure	90
15.1.3.2 Cell replacement failure	91

15.1.4 Mechanisms available for modifying intra frequency measurement reporting behaviour	91
15.1.4.1 Hysteresis	91
15.1.4.2 Time to trigger	92
15.1.4.3 Cell individual offsets	93
15.1.4.4 Forbid a Primary CCPCH to affect the reporting range	93
15.1.5 Report quantities	94
15.2 TRAFFIC VOLUME MEASUREMENTS	94
15.2.1 Traffic Volume Measurement Quantity	94
15.2.2 Traffic Volume reporting events	95
15.2.3 Traffic volume reporting mechanisms	95
15.3 UE INTERNAL MEASUREMENTS	96
15.3.1 UE internal measurement quantities	96
15.3.2 UE internal measurement reporting events	96
15.3.2.1 Reporting event 6A: The UE Tx power becomes larger than an absolute threshold	96
15.3.2.2 Reporting event 6B: The UE Tx power becomes less than an absolute threshold	96
15.3.2.3 Reporting event 6C: The UE Tx power reaches its minimum value	97
15.3.2.4 Reporting event 6D: The UE Tx power reaches its maximum value	97
15.3.2.5 Reporting event 6E: The UE RSSI reaches the UE's dynamic receiver range	98
15.4 DYNAMIC RESOURCE ALLOCATION CONTROL OF UPLINK DCH	98
16 HANDLING OF UNKNOWN, UNFORESEEN AND ERRONEOUS PROTOCOL DATA	99
17 SDL	99
18 APPENDICES: EXAMPLES OF OPERATION	99
19 HISTORY	100
1 SCOPE	9
2 REFERENCES	9
3 DEFINITIONS, SYMBOLS AND ABBREVIATIONS	9
3.1 DEFINITIONS	9
3.2 ABBREVIATIONS	9
4 GENERAL	10
5 RRC SERVICES PROVIDED TO UPPER LAYERS	12
6 SERVICES EXPECTED FROM LOWER LAYERS	12
6.1 SERVICES EXPECTED FROM LAYER 2	12
6.2 SERVICES EXPECTED FROM LAYER 1	12
7 FUNCTIONS OF RRC	12
8 ELEMENTARY RRC PROCEDURES	13
8.1 IDLE MODE PROCEDURES	13
8.1.1 Broadcast of system information	13
8.1.2 Paging	14
8.1.3 Notification	14
8.2 RRC CONNECTION ESTABLISHMENT AND RELEASE PROCEDURES	15
8.2.1 RRC Connection Establishment	15
8.2.2 RRC Connection Release	16
8.2.3 RRC Connection re-establishment	16
8.3 RRC CONNECTED MODE PROCEDURES	17
8.3.1 Radio Access Bearer Related Procedures	17
8.3.1.1 Radio Access Bearer Establishment	17
8.3.1.2 Radio Access Bearer Release	18
8.3.1.3 Radio Access Bearer and signalling link Reconfiguration	18
8.3.2 Transport Channel Reconfiguration	19

8.3.3	Transport Format Combination Control	19
8.3.4	Physical Channel Reconfiguration	20
8.3.5	Mobility Related Procedures	20
8.3.5.1	Modification of the active set when in Soft hand over	20
8.3.5.2	Hard handover (FDD and TDD hard)	21
8.3.5.3	Inter system hard hand over (GSM/BSS to UTRAN)	22
8.3.5.4	Inter system hard hand over (UTRAN to GSM/BSS, PSTN/ISDN domain services)	22
8.3.5.5	Inter system cell reselection (UTRAN to GSM/GPRS, IP domain services)	23
8.3.5.6	Inter system cell reselection (GSM/GPRS to UTRAN, IP domain services)	23
8.3.5.7	URA update	23
8.3.5.8	Cell update	24
8.3.5.9	RNTI reallocation	24
8.3.6	RRC Connected mode procedures which use Paging	25
8.3.6.1	Core network originated paging	25
8.3.6.2	UTRAN originated paging	25
8.3.7	Procedures related to measurement and monitoring	26
8.3.8	Other procedures in connected mode	28
8.3.8.1	Transmission of UE capability information	28
8.3.8.2	Sending of system information in RRC connected mode	28
8.3.8.3	Direct transfer	29
8.3.8.4	RRC status procedure	30

9 — PRIMITIVES BETWEEN RRC AND UPPER LAYERS

10 — MESSAGE AND INFORMATION ELEMENT FUNCTIONAL DEFINITION AND CONTENT

10.1	RADIO RESOURCE CONTROL MESSAGES	31
10.1.1	RRC Connection Mobility Messages	31
10.1.1.1	ACTIVE SET UPDATE	31
10.1.1.2	ACTIVE SET UPDATE COMPLETE	31
10.1.1.3	CELL UPDATE	32
10.1.1.4	CELL UPDATE CONFIRM	32
10.1.1.5	HANDOVER COMMAND	33
10.1.1.6	HANDOVER COMPLETE	34
10.1.1.7	INTER SYSTEM HANDOVER COMMAND	34
10.1.1.8	INTER SYSTEM HANDOVER FAILURE	34
10.1.1.9	URA UPDATE	35
10.1.1.10	URA UPDATE CONFIRM	35
10.1.1.11	RNTI REALLOCATION	35
10.1.1.12	RNTI REALLOCATION COMPLETE	36
10.1.2	Measurement Messages	36
10.1.2.1	MEASUREMENT CONTROL	36
10.1.2.2	MEASUREMENT REPORT	38
10.1.3	Paging and Notification Messages	39
10.1.3.1	NOTIFICATION	39
10.1.3.2	PAGING TYPE 1	39
10.1.3.3	PAGING TYPE 2	39
10.1.4	RRC Connection Establishment and maintenance messages	40
10.1.4.1	RRC CONNECTION RE ESTABLISHMENT	40
10.1.4.2	RRC CONNECTION RE ESTABLISHMENT COMPLETE	40
10.1.4.3	RRC CONNECTION RE ESTABLISHMENT REQUEST	40
10.1.4.4	RRC CONNECTION RELEASE	41
10.1.4.5	RRC CONNECTION RELEASE COMPLETE	41
10.1.4.6	RRC CONNECTION REQUEST	41
10.1.4.7	RRC CONNECTION SETUP	42
10.1.4.8	RRC CONNECTION REJECT	43
10.1.4.9	RRC STATUS	43
10.1.4.10	RRC STATUS ACK	43
10.1.5	Radio Access Bearer control messages	43
10.1.5.1	PHYSICAL CHANNEL RECONFIGURATION	43
10.1.5.2	PHYSICAL CHANNEL RECONFIGURATION COMPLETE	44
10.1.5.3	RADIO ACCESS BEARER RECONFIGURATION	44
10.1.5.4	RADIO ACCESS BEARER RECONFIGURATION COMPLETE	46
10.1.5.5	RADIO ACCESS BEARER RELEASE	46
10.1.5.6	RADIO ACCESS BEARER RELEASE COMPLETE	48
10.1.5.7	RADIO ACCESS BEARER SETUP	48

10.1.5.8 RADIO ACCESS BEARER SETUP COMPLETE	50
10.1.5.9 TRANSPORT CHANNEL RECONFIGURATION	50
10.1.5.10 TRANSPORT CHANNEL RECONFIGURATION COMPLETE	51
10.1.5.11 TRANSPORT FORMAT COMBINATION CONTROL	52
10.1.6 System Information Messages	52
10.1.6.1 SYSTEM INFORMATION	52
10.1.7 OTHER MESSAGES	54
10.1.7.1 UE CAPABILITY INFORMATION	54
10.1.7.2 UE CAPABILITY INFORMATION CONFIRM	55
10.1.7.3 DIRECT TRANSFER	55
10.2 INFORMATION ELEMENT FUNCTIONAL DEFINITIONS	56
10.2.1 CN Information elements	56
10.2.1.1 CN domain identity	56
10.2.1.2 NAS binding info	56
10.2.1.3 NAS message	56
10.2.1.4 NAS system information	56
10.2.1.5 PLMN identity	56
10.2.2 UTRAN mobility Information elements	56
10.2.2.1 Cell identity	56
10.2.2.2 Cell selection and re-selection info	56
10.2.2.3 Information for periodic cell and URA update	56
10.2.2.4 URA identity	56
10.2.2.5 URA update indicator	57
10.2.3 UE Information elements	57
10.2.3.1 Uplink access control info	57
10.2.3.2 C-RNTI	57
10.2.3.3 S-RNTI	57
10.2.3.4 SRNC identity	57
10.2.3.5 Initial UE identity	57
10.2.3.6 Activation time	57
10.2.3.7 Wait time	57
10.2.3.8 Control only state timer	58
10.2.3.9 Paging record	58
10.2.3.10 Establishment cause	58
10.2.3.11 Release cause	58
10.2.3.12 Rejection cause	58
10.2.3.13 Paging cause	58
10.2.3.14 Initial UE capability	58
10.2.3.15 Power control capability	58
10.2.3.16 Code resource capability	58
10.2.3.17 UE mode capability	58
10.2.3.18 Transport channel support capability	59
10.2.3.19 Ciphering capability	59
10.2.3.20 Macro diversity capability	59
10.2.3.21 Cell update cause	59
10.2.3.22 URA update cause	59
10.2.3.23 Number of Quick Repeat	59
10.2.3.24 Inter-system handover failure cause	59
10.2.3.25 Transmission probability	59
10.2.3.26 Maximum bit rate	60
10.2.4 Radio Access Bearer Information elements	60
10.2.4.1 RAB identity	60
10.2.4.2 RLC info	60
10.2.4.3 Signalling link type	60
10.2.4.4 RAB multiplexing info	60
10.2.5 Transport CH Information elements	61
10.2.5.1 Transport Format Combination Set	61
10.2.5.2 Transport Format Combination Subset	61
10.2.5.3 Transport channel identity	61
10.2.5.4 Transport Format Set (TFS)	61
10.2.5.5 Dynamic Control	61
10.2.5.6 Transmission time validity	61
10.2.5.7 Time duration before retry	62
10.2.5.8 Silent period duration before release	62
10.2.6 Physical CH Information elements	62
10.2.6.1 Frequency info	62

10.2.6.2 Primary CCPCH info	62
10.2.6.3 Secondary CCPCH info	62
10.2.6.4 PRACH info	62
10.2.6.5 PRACH power control info	63
10.2.6.6 Uplink DPCH info	63
10.2.6.7 Uplink DPCH power control info	63
10.2.6.8 Downlink DPCH info	63
10.2.6.9 Uplink timeslot info	63
10.2.6.10 Downlink timeslot info	63
10.2.6.11 SSDT indicator	64
10.2.6.12 Gated Transmission Control info (FFS)	64
<i>10.2.7 Measurement Information elements</i>	<i>64</i>
10.2.7.1 Measurement Identity Number	64
10.2.7.2 Measurement Command	64
10.2.7.3 Measurement Type	64
10.2.7.4 Reference time difference to cell	64
10.2.7.5 Measured time difference to cell	65
10.2.7.6 Measurement reporting mode	65
10.2.7.7 Intra frequency cell info	65
10.2.7.8 Inter frequency cell info	65
10.2.7.9 Inter system cell info	65
10.2.7.10 Traffic volume measurement object	66
10.2.7.11 Quality measurement object (FFS)	66
10.2.7.12 Intra frequency measurement quantity	66
10.2.7.13 Inter frequency measurement quantity (FFS)	66
10.2.7.14 Inter system measurement quantity (FFS)	66
10.2.7.15 Traffic volume measurement quantity	66
10.2.7.16 Quality measurement quantity (FFS)	67
10.2.7.17 Intra frequency reporting quantity	67
10.2.7.18 Inter frequency reporting quantity (FFS)	67
10.2.7.19 Inter system reporting quantity (FFS)	67
10.2.7.20 Traffic volume reporting quantity	67
10.2.7.21 Quality reporting quantity (FFS)	68
10.2.7.22 Intra frequency measurement reporting criteria	68
10.2.7.23 Inter frequency measurement reporting criteria (FFS)	69
10.2.7.24 Inter system measurement reporting criteria (FFS)	69
10.2.7.25 Traffic volume measurement reporting criteria	69
10.2.7.26 Quality measurement reporting criteria (FFS)	69
10.2.7.27 Periodical reporting criteria	69
10.2.7.28 Intra frequency measurement event results	70
10.2.7.29 Inter frequency measurement event results (FFS)	70
10.2.7.30 Inter system measurement event results (FFS)	70
10.2.7.31 Traffic volume measurement event results	70
10.2.7.32 Quality measurement event results (FFS)	70
10.2.7.33 Measured results	70
<i>10.2.8 Other Information elements</i>	<i>71</i>
10.2.8.1 BCCH modification info	71
10.2.8.2 Inter system message	71
11 MESSAGE AND INFORMATION ELEMENT ABSTRACT SYNTAX (WITH ASN.1)	71
12 MESSAGE TRANSFER SYNTAX	73
13 PROTOCOL STATES	73
14 PROTOCOL TIMERS, COUNTERS AND OTHER PARAMETERS	73
15 SPECIFIC FUNCTIONS (IF APPLICABLE)	73
16 HANDLING OF UNKNOWN, UNFORESEEN AND ERRONEOUS PROTOCOL DATA	73
17 SDL	73
18 APPENDICES: EXAMPLES OF OPERATION	73

[19 HISTORY](#) [74](#)

Intellectual Property Rights

[Editor's note: This paragraph has been modified from corresponding ETSI text in anticipation of a new version regarding 3GPP.]

IPRs essential or potentially essential to the present deliverable may have been declared to 3GPP. The information pertaining to these essential IPRs, if any, is publicly available for **3GPP members and non-members, free of charge**. This can be found in the latest version of the 3GPP Technical Report: ETR 314: "Intellectual Property Rights (IPRs); Essential or potentially Essential, IPRs notified to 3GPP in respect of 3GPP standards". The most recent update of ETR 314, is available on the 3GPP web server or on request from the Secretariat.

Pursuant to the 3GPP Interim IPR Policy, no investigation, including IPR searches, has been carried out by 3GPP. No guarantee can be given as to the existence of other IPRs not referenced in the ETR 314, which are, or may be, or may become, essential to the present document.

Foreword

This Technical Specification has been produced by the 3GPP.

The contents of the present document are subject to continuing work within the TSG and may change following formal TSG approval. Should the TSG modify the contents of this TS, it will be re-released by the TSG with an identifying change of release date and an increase in version number as follows:

Version 3.y.z

where:

- x the first digit:
 - 1 presented to TSG for information;
 - 2 presented to TSG for approval;
 - 3 Indicates TSG approved document under change control.
- y the second digit is incremented for all changes of substance, i.e. technical enhancements, corrections, updates, etc.
- z the third digit is incremented when editorial only changes have been incorporated in the specification.

1. Scope

The scope of this specification is to describe the Radio Resource Control protocol for the 3GPP radio system.

2. References

- [1] UMTS 25.XX, 'Vocabulary for the UTRAN'
 - [2] 25.301, 'Radio Interface Protocol Architecture'
 - [3] 25.303, 'Description of UE states and procedures in connected mode'
-

3. Definitions, Symbols and abbreviations

3.1 Definitions

See [1] for definition of fundamental concepts and vocabulary

3.2 Abbreviations

ACK	Acknowledgement
AICH	Acquisition Indicator CHannel
AM	Acknowledged Mode
AS	Access Stratum
ASN.1	Abstract Syntax Notation.1
BCCH	Broadcast Control Channel
BCFE	Broadcast Control Functional Entity
BER	Bite Error Rate
BLER	BLock Error Rate
BSS	Base Station Sub-system
C	Conditional
CCPCH	Common Control Physical CHannel
CCCH	Common Control Channel
CN	Core Network
CM	Call Management
CPCH	Common Packet CHannel
C-RNTI	CRNC RNTI
DCA	Dynamic Channel Allocation
DCCH	Dedicated Control Channel
DCFE	Dedicated Control Functional Entity
DCH	Dedicated Channel
DC-SAP	Dedicated Control SAP
DL	Downlink
DRAC	Dynamic Resource Allocation Control
DTCH	Dedicated Traffic Channel
FACH	Forward Access Channel
FAUSCH	Fast Uplink Signalling Channel
FDD	Frequency Division Duplex
FFS	For Further Study
GC-SAP	General Control SAP

ID	Identifier
IMEI	International Mobile Equipment Identity
IMSI	International Mobile Subscriber Identity
IP	Internet Protocol
ISCP	Interference on Signal Code Power
LAI	Location Area Identity
L1	Layer 1
L2	Layer 2
L3	Layer 3
M	Mandatory
MAC	Media Access Control
MCC	Mobile Country Code
MM	Mobility Management
MNC	Mobile Network Code
MS	Mobile Station
NAS	Non Access Stratum
Nt-SAP	Notification SAP
NW	Network
O	Optional
ODMA	Opportunity Driven Multiple Access
PCCH	Paging Control Channel
PCH	Paging Channel
PDU	Protocol Data Unit
PLMN	Public Land Mobile Network
PNFE	Paging and Notification Control Functional Entity
PRACH	Physical Random Access CHannel
P-TMSI	Packet Temporary Mobile Subscriber Identity
QoS	Quality of Service
RAB	Radio access bearer
RAI	Routing Area Identity
RACH	Random Access CHannel
RFE	Routing Functional Entity
RL	Radio Link
RLC	Radio Link Control
RNTI	Radio Network Temporary Identifier
RNC	Radio Network Controller
RRC	Radio Resource Control
RSCP	Received Signal Code Power
RSSI	Received Signal Strength Indicator
SAP	Service Access Point
SF	Spreading Factor
SIR	Signal to Interference Ratio
SSDT	Site Selection Diversity Transmission
S-RNTI	SRNC - RNTI
tbd	to be decided
TDD	Time Division Duplex
TF	Transport Format
TFCS	Transport Format Combination Set
TFS	Transport Format Set
TME	Transfer Mode Entity
TMSI	Temporary Mobile Subscriber Identity
Tr	Transparent
Tx	Transmission
UE	User Equipment
UL	Uplink
UM	Unacknowledged Mode
UMTS	Universal Mobile Telecommunications System
UNACK	Unacknowledgement
URA	UTRAN Registration Area
UTRAN	UMTS Terrestrial Radio Access Network

4. General

The functional entities of the RRC layer are described below:

- Routing of higher layer messages to different MM/CM entities (UE side) or different core network domains (UTRAN side) is handled by the Routing Function Entity (**RFE**)
- Broadcast functions are handled in the broadcast control function entity (**BCFE**). The BCFE is used to deliver the offers RRC services which are required atby the GC-SAP. The BCFE can use and usesthe lower layer services provided by the Tr-SAP and UM-SAP.
- Paging of idle mode UE(s) is controlled by the paging and notification control function entity (**PNFE**). The PNFE is used to deliver the offers RRC services which are required atby the Nt-SAP. The PNFE can use and uses the lower layer services provided by the Tr-SAP and UM-SAP.
- The Dedicated Control Function Entity (**DCFE**) handles all functions specific to one UE. The DCFE is used to deliver the RRC services which are required at the offers RRC services by the DC-SAP and can use lower layer services of UM/AM-SAP and Tr-SAP depending on the message to be sent and on the current UE service state.
- The Transfer Mode Entity (TME) handles the mapping between the different entities inside the RRC layer and the SAP's provided by RLC.

Logical information exchange is necessary also between the RRC sublayer functional entities. Most of that is implementation dependent and not necessary to present in detail in a specification.

Figure 1~~Figure 1~~ shows the RRC model for the UE side and Figure 3~~Figure 2~~ shows the RRC model for the UTRAN side.

[Editors note: Some further clarification in the diagrams may be beneficial to acknowledge the fact that a DC-SAP for example might be offered over a dedicated channel (with RRC terminated in SRNC) whereas GC-SAP and Nt-SAP may be offered over BCCH, PCH respectively in which cases RRC is located in Node B. It could be concluded from the figure that these channels use the same SAP offered by RLC (Tr-SAP, UM-SAP, AM-SAP) whereas in fact they will use different SAP's, though the SAP type might be the same]

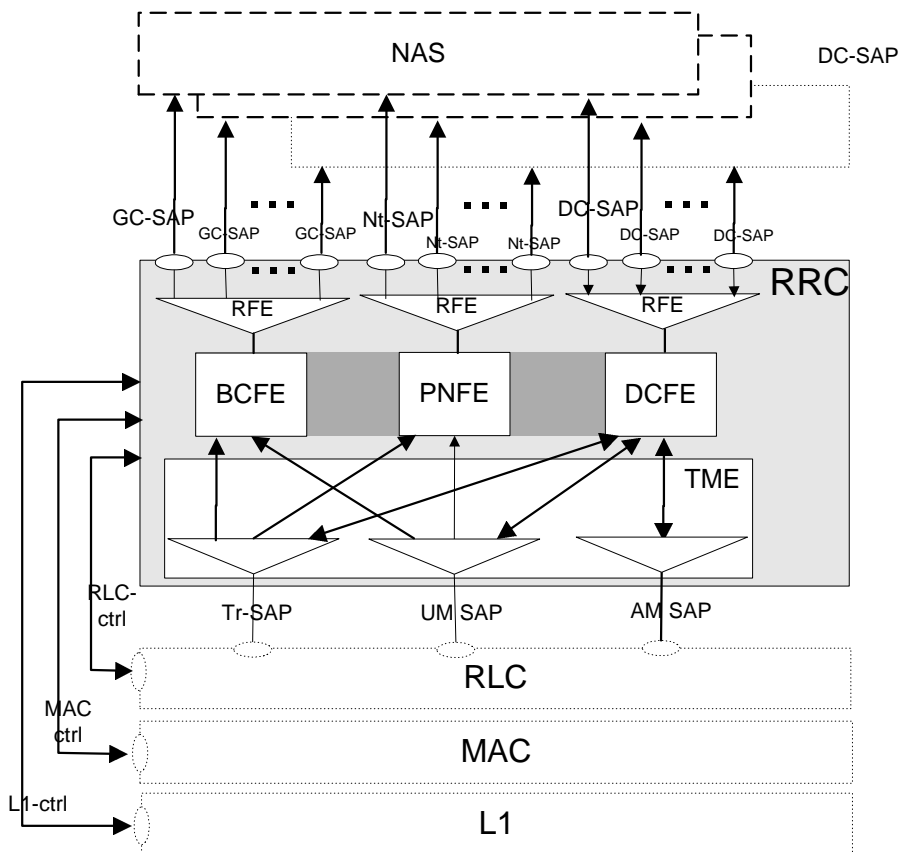

Figure 1) UE side model of RRC

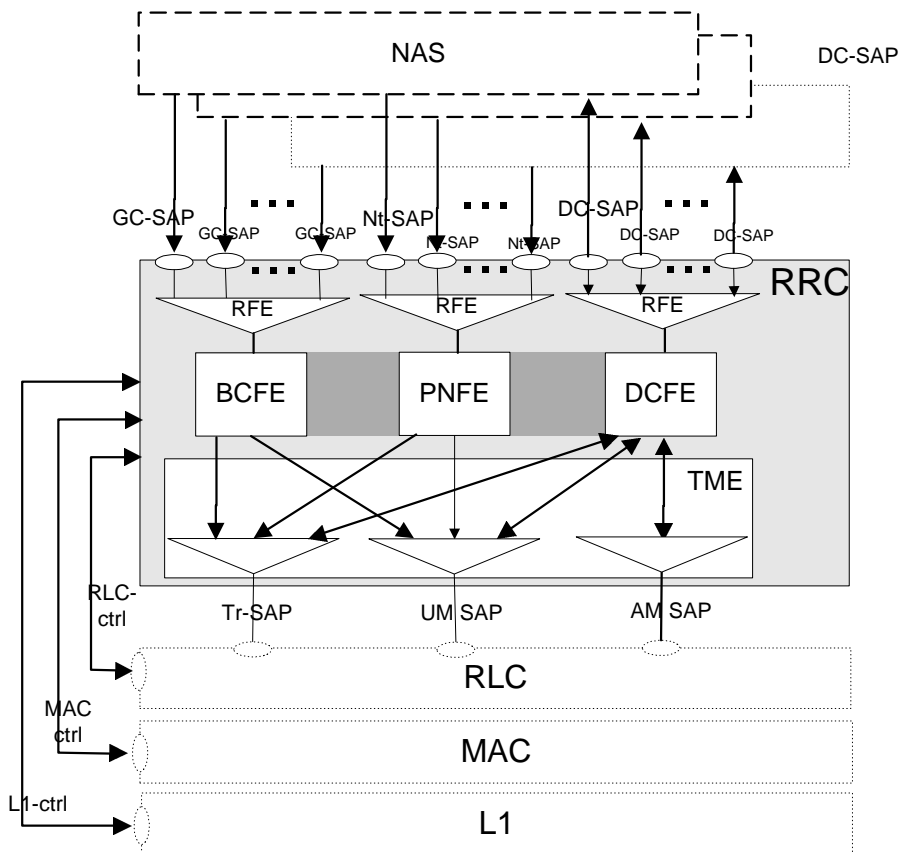

Figure 32) UTRAN side RRC model

5 RRC Services provided to upper layers

The RRC offers the following services to upper layers, a description of these services is provided in [2].

- **General Control**
- **Notification**
- **Dedicated control**

6 Services expected from lower layers

6.1 Services expected from Layer 2

6.2 Services expected from Layer 1

7 Functions of RRC

The RRC performs the functions listed below, a more detailed description of these functions is provided in [25.301-04](#):

- **Broadcast of information provided by the non-access stratum (Core Network).**
- **Broadcast of information related to the access stratum.**
- **Establishment, maintenance and release of an RRC connection between the UE and UTRAN.**
- **Establishment, reconfiguration and release of Radio Access Bearers**
- **Assignment, reconfiguration and release of radio resources for the RRC connection.**
- **RRC connection mobility functions.**
- ~~Arbitration of the radio resource allocation between the cells.~~
- **Routing of higher layer PDU's**
- **Control of requested QoS.**
- **UE measurement reporting and control of the reporting.**
- **Outer loop power control.**
- **Control of ciphering.**
- **Slow DCA.**
- **Broadcast of ODMA relay node neighbour information**
- **Collation of ODMA relay nodes neighbour lists and gradient information**
- **Maintenance of number of ODMA relay node neighbours**
- **Establishment, maintenance and release of a route between ODMA relay nodes**
- **Interworking between the Gateway ODMA relay node and the UTRAN**
- **Contention resolution (TDD mode)**
- **Paging/notification.**

- [Initial cell selection and re-selection in idle mode.](#)
- [Arbitration of radio resources on uplink DCH](#)

The following functions are regarded as further study items:

~~Initial cell selection and re-selection in idle mode.~~

- Congestion control.

• [Arbitration of the radio resource allocation between the cells.](#)

~~Routing of higher layer PDU's (in UE side to correct higher layer entity and in UTRAN side to correct RANAP entity). The requirement for this function will be dependent on the decision made by SMG12.~~

8 Elementary RRC procedures

This section describes elementary RRC procedures used in the idle mode and in the connected mode. More description on the different UE modes is provided in [2]. This section also describes procedures for establishing and releasing an RRC connection.

8.1 Idle mode procedures

8.1.1 Broadcast of system information

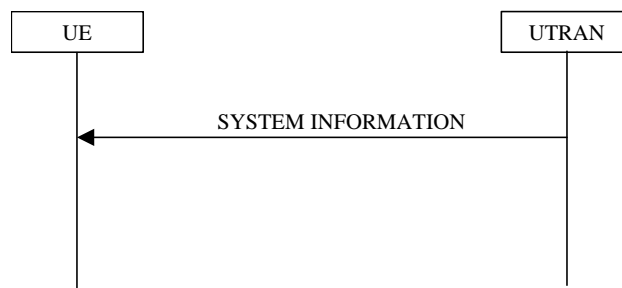

Figure 53) Procedure for broadcast of system information

This procedure is used for broadcasting system information from the network to all UEs in a cell. Only UEs that listen to the logical channel BCCH can be reached by this procedure. The system information is repeated on a regular basis and it includes information from both the access stratum and the non-access stratum. The initiative to change the system information can come from both the access stratum and non-access stratum.

The system information elements are broadcast in *system information blocks*. A system information block groups together system information elements of the same nature. Different system information blocks may have different characteristics, e.g. regarding their repetition rate and the requirements on UEs to re-read/update the system information blocks.

The system information is organised as a tree. A *master information block* gives references to a number of system information blocks in a cell, including scheduling information for those system information blocks. The master information block is scheduled with at a fixed pre-defined repetition rate.

The system information blocks contain the actual system information and/or references to other system information blocks including scheduling information for those system information blocks.

Note: A system information block may be segmented and carried in several transport blocks, but this mechanism is FFS.

~~Figure 1~~~~Figure 6~~~~Figure 4~~ illustrates the relationship between the master information block and the system information blocks in a cell.

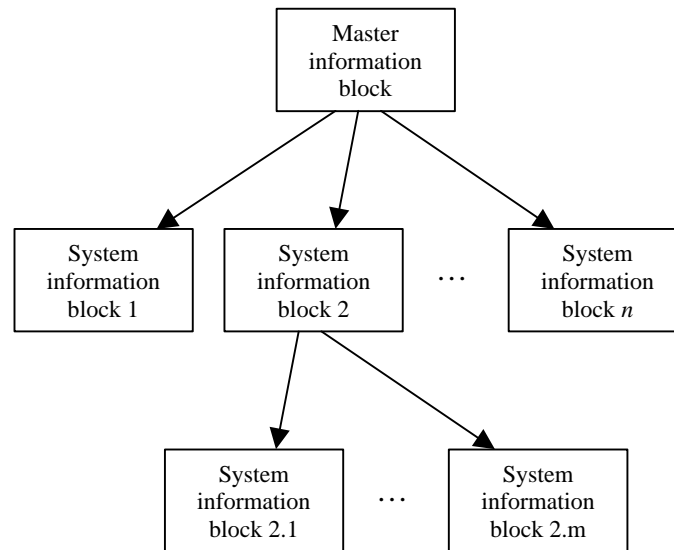

Figure 64 Figure 1. The overall structure of system information.

~~The SYSTEM INFORMATION message is regularly broadcast on the BCH by the UTRAN. Based on this information the mobile station is able to decide whether and how it may gain access to the system via the current cell.~~

~~The contents of the SYSTEM INFORMATION messages can come from RRC and from the physical layer measurements of each cell [Editors note: Other sources for the system information are also allowed].~~

The information may be grouped into the following classes:

- information giving unique identification of the current network, location area, UTRAN registration area and cell
- information used for candidate cell measurements for handover and cell selection procedures
- information describing the current control channel structure
- information for controlling the random access channel utilization
- information defining different options supported within the cell
- protocol information

[Note: The actual grouping will be defined when the complete set of system information blocks have been specified. messages that forms the system information is FFS. However, basically the same elementary procedure can be applied for all messages.]

When a system information blocks on the BCCH isare modified, the message PAGING TYPE 1 can beis sent to all UEs on the PCCH to inform UE's about the changes. The message includes the information element BCCH Modification Information.

[Note that other options will also be available to force the UE to re-read SYSTEM INFORMATION, for example timers in the UE could be used to trigger the UE into re-reading frequently changing SYSTEM INFORMATION].

8.1.2 Paging

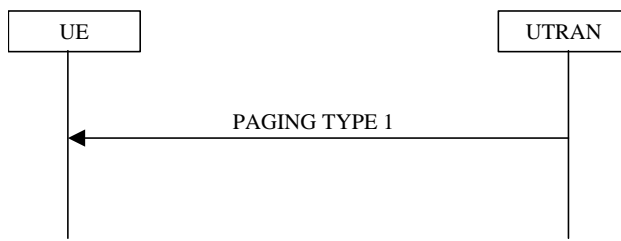

Figure 85) Paging procedure

This procedure is used to broadcast a PAGING TYPE 1 message from the network to selected UEs which are in idle mode. Only UEs which listen to the correct paging group can be reached by this procedure. The PAGING TYPE 1 message can be sent to either one or many UEs at the same time.

[Note, the following is FFS]: The PAGING TYPE 1 message includes BCCH Modification Information, which indicates the modification of the System Information on BCCH. The coding of BCCH Modification Information is FFS.

[Note: The addresses which are to be used in the paging message (eg IMUI etc) are still to be defined]

[Note: The number of addresses to be used in the paging message needs to be defined]

[Note: the requirement to have different paging messages for UTRAN originated and CN originated RRC connected mode paging needs to be confirmed]

8.1.3 Notification



Figure 96) Notification procedure

This procedure is used for broadcast of notification information to selected UEs in a cell. Only UEs that listen to the correct notification group can be reached by this procedure. The initiative to send a NOTIFICATION can come from both the access stratum and the non-access stratum. NOTIFICATION can be sent to either one or many UEs at the same time.

[Note: Notification may be cell specific]

[Note: The usage of this procedure is FFS.]

8.2 RRC connection establishment and release procedures

8.2.1 RRC Connection Establishment

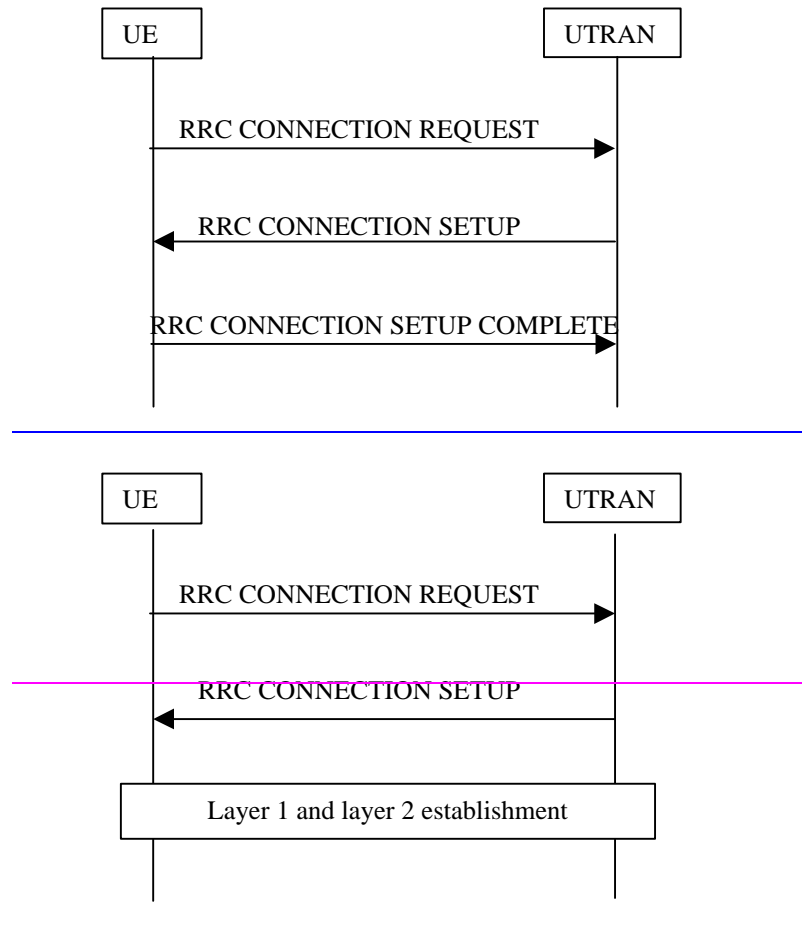

Figure 107) Procedure for RRC connection establishment

This procedure is initiated from the UE side to establish an RRC connection, as a result of either:

- (1) A request from the non-access stratum to establish the first signalling connection for the UE [Note: For a GSM-based Core Network some examples of reasons are: CM Establishment Request and Location Update Request.], or
- (2) A received paging request. [Note: Whether the RRC connection is established with or without an explicit request from UE non-access stratum in this case is FFS.]

The RRC connection establishment is initiated by the UE, which leaves the idle mode and sends an RRC CONNECTION REQUEST message using unassured mode on the uplink CCCH. [Note: The initial identification of the UE is FFS.]

As an initial identification in the RRC CONNECTION REQUEST message the UE uses a unique Non access stratum identity. This NAS identity could be either TMSI + LAI, P-TMSI + RAI, IMSI or IMEI. [Note: This is pending confirmation from WG1 that the RACH can support the required payload when this type of ID is used]

The UTRAN makes an assignment of radio resources and the Radio Network Temporary Identity (RNTI) to be used by the UE. The UTRAN then sends an RRC CONNECTION SETUP message to the UE using unassured mode on the downlink CCCH. The message includes radio resource parameters and the RNTI.

The UE then configures the layer 2 and layer 1 processing required to support for the DCCH according to using the radio resource parameters.

The procedure successfully ends when the layer 2 signalling link is established on the DCCH, network receives an RRC CONNECTION SETUP COMPLETE message. This message, which is sent using acknowledged data transfer on the DCCH, confirms that the UE has completed the procedure assigned parameters.

[Note: The necessity of an explicit RRC CONNECTION SETUP COMPLETE MESSAGE from the UE to the UTRAN on layer 3 is FFS. One assumption is, that there is an explicit layer 2 peer to peer signalling to establish the signalling link, making an explicit RRC CONNECTION SETUP COMPLETE message on layer 3 unnecessary.]

Note also that on receipt of an RRC CONNECTION REQUEST message, the RNC can allocate a FAUSCH channel for the UE for the particular cell ~~o,~~ in which the UE is camping. ~~Alternatively the RNC can allocate on, or~~ FAUSCH channels for ~~each of~~ a number of cells ~~within of~~ the URA, in which the UE is currently staying, ~~though this will~~ depend~~ing~~ on the type of UE. The FAUSCH channels allocated are conveyed to the UE in the RRC CONNECTION SETUP message.

The following procedure which could be used during RRC connection establishment is for further study:

On receipt of an RRC CONNECTION REQUEST message, the RNC may allocate a dedicated channel to the mobile station. It is also possible to setup macrodiversity at this point. To do so means that the RRC CONNECTION REQUEST message must contain a measurement report. In this case, the RNC executes branch addition (physical channel activation) to each cell (/NodeB) that will be included in the active set. After the physical channel(s) are setup on the UTRAN side, the RRC CONNECTION SETUP message is sent to the UE on the FACH channel. When the UE has activated the physical channels in the active set, it returns an RRC CONNECTION SETUP COMPLETE message.

8.2.2 RRC Connection Release

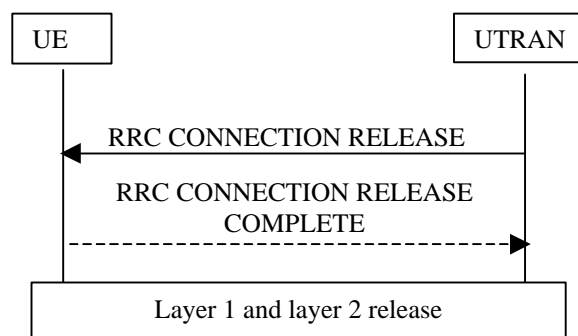

Figure 118) RRC Connection release procedure

A normal RRC connection release procedure is initiated from the UTRAN, e.g. when the last Signaling Connection is released. [Note: Release in case of RRC connection failure is FFS.] [Note: Possibility for UE initiated RRC connection release is FFS.]

Two variants of this procedure have been identified:

- RRC connection release from state where dedicated physical channel is available
- RRC connection release from state where there is no dedicated physical channel

In the former case (a) the UTRAN sends an RRC CONNECTION RELEASE message to the UE using acknowledged mode on the DCCH. The UE then leaves the Connected Mode and initiates release of the layer 2 signalling link. The RRC Connection Release procedure ends when all UE dedicated resources (such as radio resources and radio access bearers) tied to the RRC connection are released and the RRC layer is transferred to idle mode.

In the latter case (b) the RRC layer entity in the network issues an RRC CONNECTION RELEASE message using unacknowledged mode on the DCCH. Upon reception of this message the UE-RRC sends an RRC CONNECTION RELEASE COMPLETE message to UTRAN using acknowledged mode on the DCCH. [Note: Depending on RLC design, the acknowledgement to RRC CONNECTION RELEASE could be piggybacked to the RRC CONNECTION RELEASE COMPLETE MESSAGE, resulting in no additional messages. Therefore acked / unacked transmission is considered FFS.] After receiving the RRC CONNECTION RELEASE COMPLETE message the network RRC layer releases L2 resources and the RRC entity dedicated to this UE goes to Idle Mode. On receipt of the RRC CONNECTION RELEASE COMPLETE message the network also releases any the FAUSCH channels which were allocated to for the UE going to idle mode if FAUSCH channels have been allocated during RRC connection establishment.

8.2.3 RRC Connection re-establishment

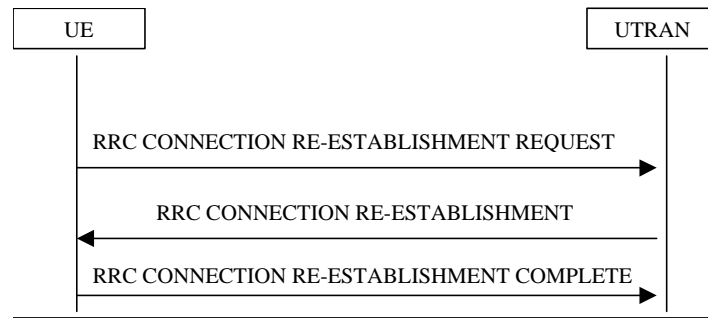

Figure 129) RRC Connection re-establishment

RRC connection re-establishment is needed, when a UE loses [the](#) radio connection due to e.g. radio link failure. After [having selected](#) a new cell [has been selected](#), the UE RRC sends the NW RRC an RRC CONNECTION RE-ESTABLISHMENT REQUEST message. The NW RRC configures the NW and acknowledges the connection re-establishment to the UE RRC with an RRC CONNECTION RE-ESTABLISHMENT message. This message may contain the FAUSCH channel(s) valid for this cell, and possibly other cells of the same URA, if FAUSCH channels have been allocated earlier. The UE RRC configures the UE L1 to activate the new radio link(s). After the UE has synchronised to at least one radio link, the MAC and RLC layers can be configured (if necessary).

After the UE has completed its configuration, it transmits an RRC CONNECTION RE-ESTABLISHMENT COMPLETE message to the network on the DCCH.

[Note: The necessity of an explicit RRC CONNECTION REESTABLISHMENT COMPLETE message to be sent from the UE to the UTRAN on layer 3 is FFS. One assumption is, that there is an explicit layer 2 peer to peer signalling to establish the signalling link, making an explicit RRC CONNECTION REESTABLISHMENT COMPLETE message on layer 3 unnecessary].

8.3 RRC connected mode procedures

8.3.1 Radio Access Bearer Related Procedures

8.3.1.1 Radio Access Bearer Establishment

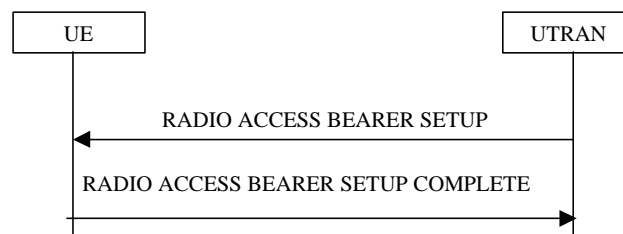

Figure 1310) Radio Access Bearer Establishment Procedure

This procedure establishes a new radio access bearer. The establishment [uses the includes, based on](#) QoS [requirements in order to](#), assignment [of the appropriate](#) RLC parameters, multiplexing priority for the DTCH, scheduling priority for DCH, TFS for DCH and update of TFCS. It may also include assignment of a physical channel(s) and change of the used transport channel types / RRC state.

There are a number of alternative methods by which radio access bearers may be established:

- a) Radio Access Bearer Establishment with dDedicated pPhysical cChannel aActivation
- b) Radio Access Bearer Establishment with uUnsynchronised dDedicated pPhysical cChannel mModification
- c) Radio Access Bearer Establishment with sSynchronised dDedicated pPhysical cChannel mModification
- d) Radio Access Bearer Establishment without dDedicated pPhysical cChannel

A Radio Access Bearer Establishment is initiated when the RRC layer in the network sends a RADIO ACCESS BEARER SETUP message to its peer entity. This message contains L1, MAC and RLC parameters and in the synchronised case an activation time. RRC on the UE side then configures L1 and MAC and creates a new RLC entity associated with the new radio access bearer. A similar reconfiguration is also done on the network side. The UE then sends a RADIO ACCESS BEARER SETUP COMPLETE message back to the network.

[Note: The possibility of establishing multiple radio access bearers within one message is FFS]

8.3.1.2 Radio Access Bearer Release

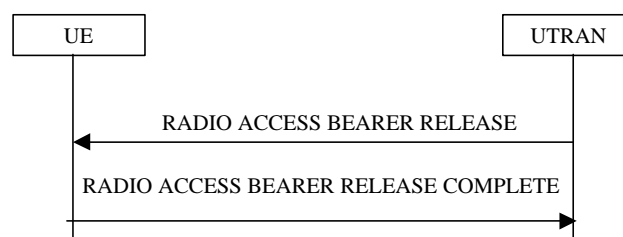

Figure 1411) Radio Access Bearer Release Procedure

This procedure releases a radio access bearer. The RLC entity for the radio access bearer is released. The procedure may also release a DCH, which affects the TFCS. It may include release of physical channel(s) and change of the used transport channel types / RRC state.

The Radio Access Bearer Release procedure is initiated by the RRC layer on the NW side. A RADIO ACCESS BEARER RELEASE message is sent from the RRC layer in the network to its peer entity in the UE. This message includes possible new L1, MAC and RLC parameters for remaining radio access bearers and identification of the radio access bearer to be released. [Note: In synchronised case a specific activation time would be needed for the change of L1 and L2 configuration to avoid data loss.]

The RRC on the UE side configures L1 and MAC, and releases the RLC entity associated to the released radio access bearer. A similar reconfiguration is also done on the network side.

Finally, RRC on the UE side sends a RADIO ACCESS BEARER RELEASE COMPLETE message to the network.

Currently the following alternative methods have been identified by which Radio Access Bearers may be released:

- a) Radio Access Bearer Release with unsynchronised dedicated physical channel modification
- b) Radio Access Bearer Release with synchronised dedicated physical channel modification
- c) Radio Access Bearer Release without dedicated physical channel modification

[Note: When a radio access bearer carried on a DCH is released, it is FFS, whether the UE should acknowledge the RADIO ACCESS BEARER RELEASE message before making the reconfiguration (on the DCH) or after making the reconfiguration (on the RACH)]

[Note: The possibility of releasing multiple radio access bearers within one message is FFS]

8.3.1.3 Radio Access Bearer and signalling link Reconfiguration

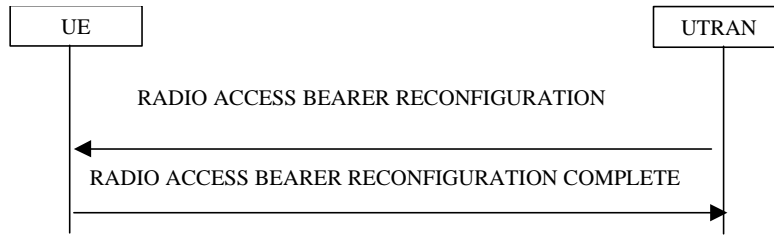

Figure 1512) Radio Access Bearer and signalling link Reconfiguration Procedure

This procedure reconfigures parameters for a radio access bearer or the signalling link to reflect a change in QoS. It may include change of RLC parameters, change of multiplexing priority for DTCH/DCCH, change of DCH scheduling priority, change of TFS for DCH, change of TFCS, assignment or release of physical channel(s) and change of used transport channel types.

Currently identified options by which Radio Access Bearers may be reconfigured:

- a) Synchronised Radio Access Bearer reconfiguration
- b) Unsynchronised Radio Access Bearer reconfiguration

[Note: When the reconfiguration involves a change of transport channel (eg. from DCH/DCH to RACH/FACH), it is FFS, whether the UE should acknowledge the RADIO ACCESS BEARER RECONFIGURATION message before making the reconfiguration (eg. on the DCH) or after making the reconfiguration (eg. on the RACH)]

[Note: The possibility of reconfiguring multiple radio access bearers and signalling links within one message is FFS]

8.3.2 Transport Channel Reconfiguration

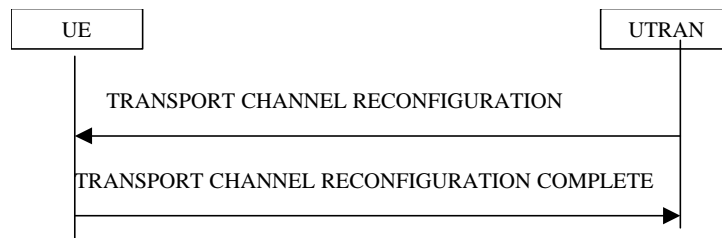

Figure 1613) Procedure for transport channel reconfiguration

This procedure configures parameters related to a transport channel such as the TFS. The procedure also assigns a TFCS and may change physical channel parameters to reflect a reconfiguration of a transport channel in use.

A change of the transport format set for a transport channel is triggered in the RRC layer in the network. A TRANSPORT CHANNEL RECONFIGURATION message is then sent from the RRC layer in the network to its peer entity. This message contains the new transport format set, a new transport format combination [set](#) and may include physical channel parameters, [i.e. new parameters for L1 and MAC](#). *[Note 1: In a synchronised procedure a specific activation time is needed for the change of L1 and L2 configuration to avoid data loss.]* When this message is received in the UE a reconfiguration of L1 and MAC is done. A similar reconfiguration is also done on the network side. Finally, a TRANSPORT CHANNEL RECONFIGURATION COMPLETE message is returned to the network.

Currently identified options by which transport channels may be reconfigured:

- a) Synchronised transport format set reconfiguration
- b) Unsynchronised transport format set reconfiguration
- c) Pre-configuration of TFS/TFCS for a transport channel not yet in use

[Note: When the reconfiguration involves a change of transport channel it is [for further study](#) FFS, on what channel the UE should acknowledge the TRANSPORT CHANNEL RECONFIGURATION message, i.e. whether it should

acknowledge before making the reconfiguration (eg. on the DCH) or after making the reconfiguration (eg. on the RACH)]

[Note: The possibility of reconfiguring multiple transport channels within one message is FFS]

8.3.3 Transport Format Combination Control

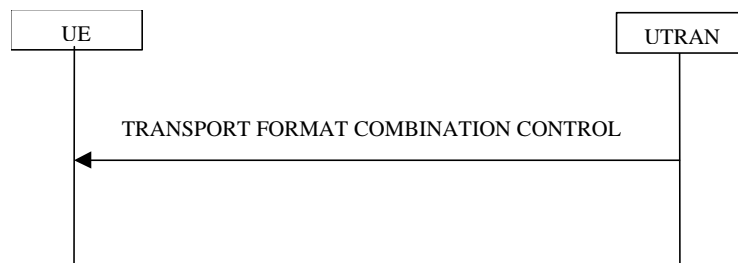

Figure 17.14) Transport Format Combination Control Procedure

The network uses this procedure to control which transport format combinations (within the transport format combination set) can be used by the UE in the uplink. An example of when this procedure might be used is when a congestion situation occurs such that it is desirable to temporarily restrict the TFC's in use.

This procedure is initiated with a TRANSPORT FORMAT COMBINATION CONTROL message sent from the network to the UE. This message defines the subset of the complete Transport Format Combination Set which the UE is allowed to use, or in case of removing/adding a temporary restriction, a TFCS which is identical to the complete original set. The UE then reconfigures MAC which thereafter uses the new TFC set. The TRANSPORT FORMAT COMBINATION CONTROL message may be sent as unacknowledged data transfer (FFS) since it is assumed that it does not matter if one UE out of many misses this information and stays with the old TFCS.

8.3.454 Physical Channel Reconfiguration

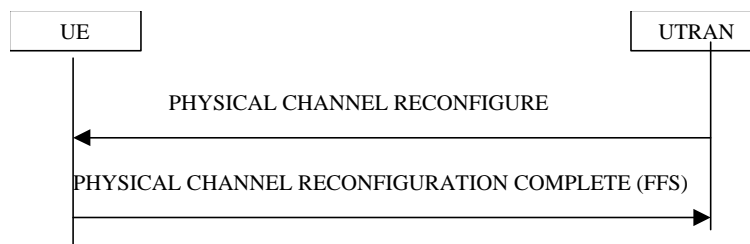

Figure 1816) Physical Channel Reconfiguration procedure

This procedure may assign, replace or release a set of physical channels used by a UE. As a result of this, it may also change the used transport channel type (and RRC state). For example, when the first physical channel is assigned the UE enters the DCH/DCH state. When the last physical channel is released the UE leaves the DCH/DCH state and enters a state (and transport channel type) indicated by the network. A special case of using this procedure is to change the DL channelization code of a dedicated physical channel. [Note: The procedure does not change the active set, in the downlink the same number of physical channels are added or replaced for each radio link.]

Currently identified motivations for using this procedure (methods by which physical channels may be reconfigured):

- Assignment of dedicated physical channel (switch from common channels to dedicated physical channel)
- Synchronised replacement (modification) of dedicated physical channel (eg. for D/L code tree re-organisation)
- Release dedicated physical channel (switch from dedicated physical channel to common channels).
- This procedure can also be used to add further FAUSCH channels (e.g. for use in other cells of the URA, to which a UE might move in the future when the UE already has an RRC connection.)

8.3.565 Mobility Related Procedures

8.3.565.1 Modification of the active set when in Soft hand-over

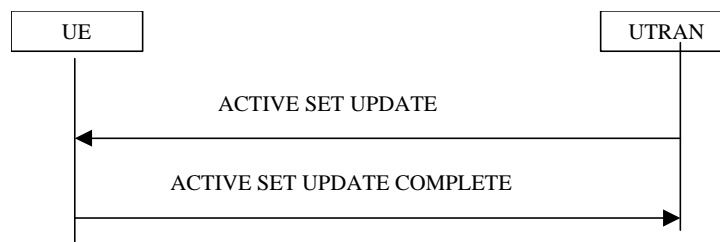

Figure 1917) Procedure for modifying the active set when in soft hand-over

There are three alternative ways of modifying the active set which have been identified:

- Radio link addition
- Radio link removal
- Combined radio link addition and removal

Radio link addition is triggered in the network RRC layer. The NW RRC first configures the new radio link. Transmission and reception begin immediately. The NW RRC then sends an ACTIVE SET UPDATE message to the UE RRC. The UE RRC configures layer 1 to begin reception. After confirmation from the physical layer in the UE an ACTIVE SET UPDATE COMPLETE message is sent to the NW RRC

Radio link removal is triggered by the network RRC layer. The radio link is first deactivated by the UE and then in the NW. The NW RRC sends an ACTIVE SET UPDATE message to the UE RRC. The UE RRC requests UE L1 to terminate reception of the radio link(s) to be removed. After this the UE RRC acknowledges radio link removal with an

ACTIVE SET UPDATE COMPLETE message to the NW RRC. The NW RRC proceeds to request the NW L1 to release the radio link.

The NW RRC determines the need for radio link replacement. When radio links are to be replaced, the NW RRC first configures the NW L1 to activate the radio link(s) that are being added. The NW RRC then sends an ACTIVE SET UPDATE message to the UE RRC, which configures the UE L1 to terminate reception on the removed radio link(s) and begin reception on the added radio link(s). If the UE active set is full, an old radio link has to be removed before a new one can be added. If the UE has only one radio link, then the replacement must be done in reverse order (first add, then remove). *Note: The present assumption is that the order of the replacement can be left to the UE.* The UE RRC acknowledges the replacement with an ACTIVE SET UPDATE COMPLETE message. The NW RRC then configures the NW L1 to terminate reception and transmission on the removed radio link.

[Editors note: Presumably the radio link replacement procedure can be used for intra-frequency(make before break) hard hand-off]

[Editor's note: TDD active set update will also be supported if the L1 group identifies the requirement]

8.3.565.2 Hard handover (FDD and TDD hard)

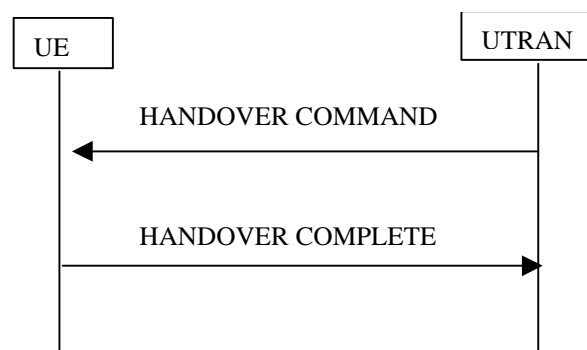

Figure 2018) Inter-frequency hard handover

The NW RRC determines the need for inter-frequency hard handover and then configures the NW L1 to activate the new radio links. The NW L1 begins transmission and reception on the new links immediately. The NW RRC then sends the UE RRC a HANOVER COMMAND message. The message indicates the radio resources that should be used for the new radio link, and can include a FAUSCH channel for the new cell, if the UE has not already been assigned a valid FAUSCH channel for the new cell. The UE RRC configures the UE L1 to terminate reception on the old radio link and begin reception on the new radio link.

After the UE L1 has achieved downlink synchronisation on the new frequency, a L2 link is established and the UE RRC sends a HANOVER COMPLETE message to the NW RRC. After the L3 acknowledgement has been received, the NW RRC configures the NW L1 to terminate reception and transmission on the old radio link.

[Note 1: Whether it should be possible to setup several radio links immediately on the new frequency is FFS.]

[Note 2: The suspension and resumption of the CC and MM signalling during handover is FFS.]

8.3.565.3 Inter system hard hand-over (GSM/BSS to UTRAN)

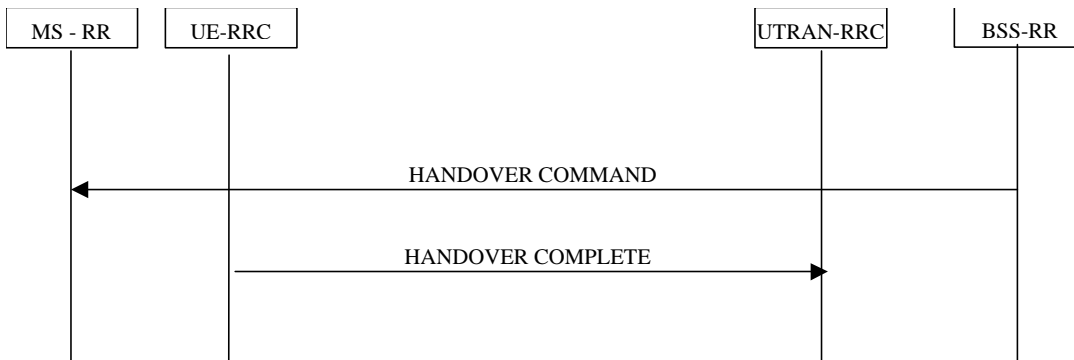

Figure 2119) Procedure for Inter-system hard hand-over - GSM to UTRAN

The handover from GSM/BSS to UTRAN for a dual-mode GSM MS / UMTS UE is described.

On the network side, the RRC layer performs admission control and radio resource allocation, assigning an RNTI for the RRC connection and selecting radio resource parameters (such as transport channel type, transport format sets, etc).

The selected parameters including the RNTI, are transmitted to the UE via the upgraded GSM RR message HANDOVER COMMAND. Upon reception of the HANDOVER COMMAND message, the UE RRC configures L1 and L2 using these parameters to locally establish the DCCH logical channel. Layer 1 indicates to RRC when it has reached synchronisation. An RLC signalling link establishment is then initiated by the UE. A HANDOVER COMPLETE message is finally sent by the UE RRC.

8.3.565.4 Inter system hard hand-over (UTRAN to GSM/BSS, PSTN/ISDN domain services)

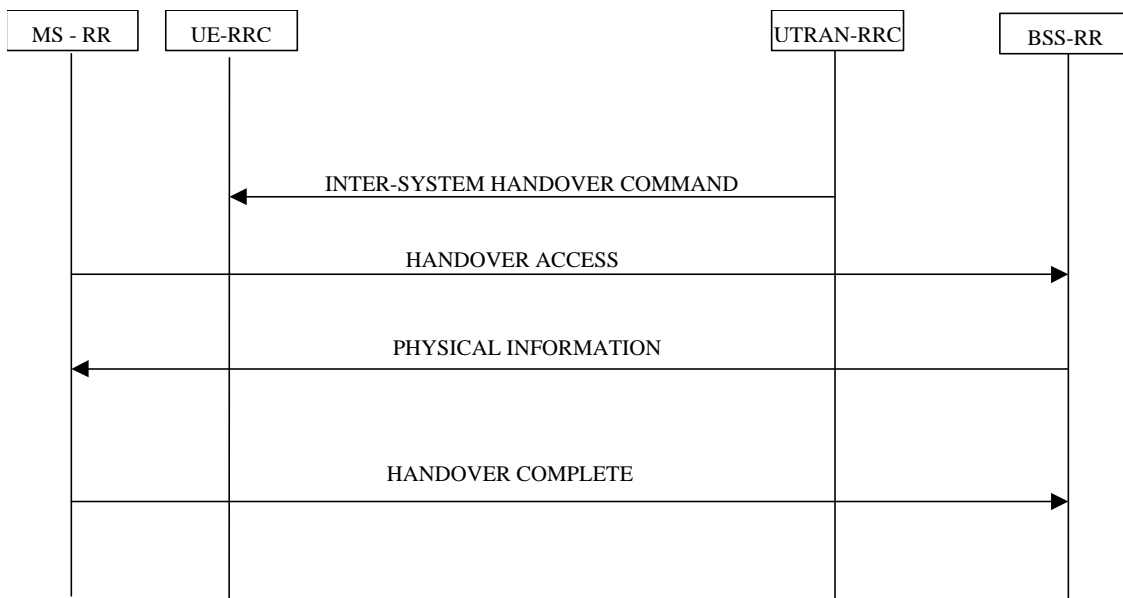

Figure 2220) Inter system hard hand-over (UTRAN to GSM/BSS), PSTN/ISDN services, successful case

[Note: The scope of this description is restricted to a UE having a connection only to PSTN/ISDN services, i.e. no simultaneous IP connection]

For PSTN/ISDN domain services UTRAN Inter-System Handover procedure is initiated from the UTRAN.

The UTRAN RRC sends an INTER-SYSTEM HANDOVER COMMAND (type UTRAN-to-BSS HARD HANDOVER) to the UE to start the execution of the handover. This message contains all the information needed for the UE to be able to switch to the GSM cell and perform a GSM handover.

Upon reception of the HANDOVER COMMAND message, the UE RRC layer can then locally release the resources on the RLC, MAC and physical layers of the UE.

After having switched to the assigned GSM channel specified in the INTER-SYSTEM HANDOVER COMMAND, the MS RR sends a HANDOVER ACCESS message in successive layer 1 frames, just as it typically would have done for a conventional GSM handover initiation.

When the BSS-RR has received the HANDOVER ACCESS it indicates this to the CN/AS by sending a HANDOVER DETECT message. The BSS-RR sends a PHYSICAL INFORMATION message to the GSM MS in unacknowledged mode that contains various fields of physical layer -related information allowing a proper transmission by the MS. After layer 1 and layer 2 connections are successfully established, the GSM MS returns the HANDOVER COMPLETE message.

The UTRAN is then able to release the resources that were used by the UE in UTRAN Connected Mode.

If the UE is unable to execute the Inter-System Handover or if low layer failure ~~occurs~~ happens on the UE side ~~on the~~ GSM/BSS channel ~~prior to before~~ HANDOVER COMPLETE ~~being has been~~ sent ~~then~~, the UE deactivates the new GSM/BSS channel and reactivates the UTRAN connection.

The UE then sends ~~an~~ INTER-SYSTEM HANDOVER FAILURE message and resumes normal operation as if no Inter-System Handover ~~attempt had have~~ occurred.

8.3.565.5 -Inter system cell reselection (UTRAN to GSM/GPRS, IP domain services)

For IP domain services, intersystem cell reselection from UTRAN to GSM/GPRS is initiated by the UE, or ordered by the network with the INTER-SYSTEM HANDOVER COMMAND message.

8.3.565.6 Inter system cell reselection (GSM/GPRS to UTRAN, IP domain services)

For IP domain services, intersystem cell reselection from GSM/GPRS to UTRAN is initiated by the ~~MS~~ UE or by GSM/BSS according to GSM/GPRS specifications.

8.3.565.7 URA update

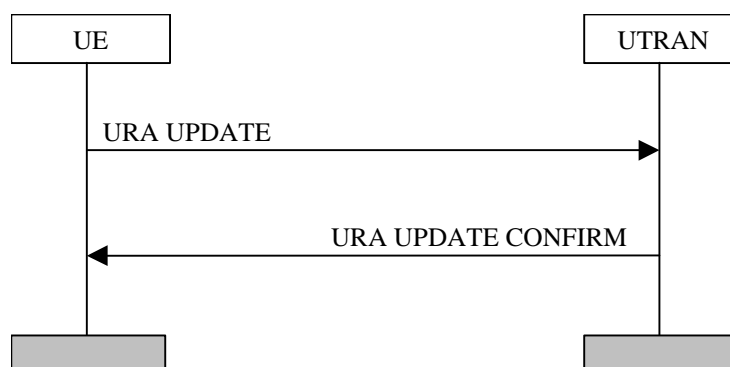

Figure 2321) URA update procedure.

The URA update procedure is normally used by the UE to inform the UTRAN that the UE has switched to a new UTRAN registration area. In ~~that this~~ case, the procedure is triggered after change of cell and after the UE has ~~ve read information broadcasted decoded from the BCCH the URA identifier(s) valid in that cell, by UTRAN indicating change of URA.~~ The procedure can also be triggered by expiry of a URA update periodicity timer in the UE.

UTRAN registration areas may be hierarchical to avoid excessive signalling. This means that several URA identifiers may be broadcast in one cell and that different UEs in one cell may reside in different URAs. A UE in URA connected state shall always have one and only one valid URA.

To perform the URA update procedure, the UE shall establish a radio link to a cell in the new URA. After that the UE shall send a URA UPDATE message to the UTRAN. Upon reception of the message the UTRAN registers the change of URA, and sends a URA UPDATE CONFIRM message to the UE. The URA UPDATE CONFIRM message may include a new C-RNTI and/or S-RNTI plus SRNC identity. In the latter case, the UE shall transmit an RNTI REALLOCATION COMPLETE message as confirmation. In cells where multiple URAs are valid, the UTRAN shall assign the URA to the UE in the URA UPDATE CONFIRM message. The URA UPDATE CONFIRM message may also contain new NAS system information.

[Note1: Whether it should be possible for the UTRAN to trigger a URA update request from the UE is FFS.]

8.3.565.8 Cell update

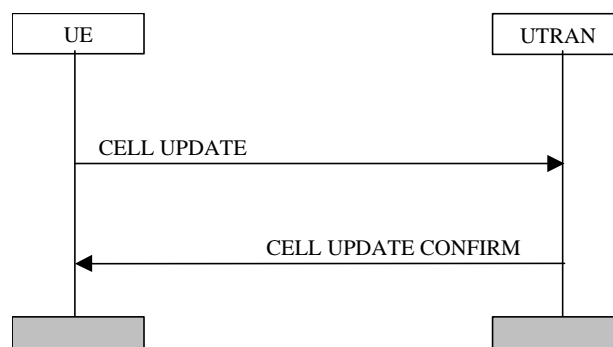

Figure 2422) Cell update procedure.

The cell update procedure is normally used by the UE to inform the UTRAN that the UE has switched to a new cell. In this case, the procedure is a forward handover procedure, and is triggered after change of cell and after the UE has read information broadcasted by UTRAN. The procedure can also be triggered by expiry of a cell update periodicity timer in the UE or in cases when the UE requests a new C-RNTI.

In case of cell reselection, the UE abandons the radio link to the old cell and establishes a radio link to the new cell. After that the UE sends a CELL UPDATE message to the UTRAN. Upon reception of the message the UTRAN registers any change of cell, and sends a CELL UPDATE CONFIRM message to the UE.

The CELL UPDATE CONFIRM message may include a new C-RNTI and S-RNTI plus SRNC identity. In this case the UE configures layer 2 to use the new identities and returns an RNTI REALLOCATION COMPLETE message as confirmation. In the CELL UPDATE CONFIRM message, the network can instruct the UE to start updating its location on URA level. In the transition to URA connected state, the CELL UPDATE CONFIRM message shall include a URA assignment, if multiple URAs are valid in the current cell. It may also contain new NAS system information.

The cell update procedure can also include an update on the updating of which FAUSCH channel should be used in the new cell.

In case the UE is assigned a new C-RNTI and/or S-RNTI plus SRNC identity, a RNTI REALLOCATION COMPLETE message is sent by the UE to the network.

[Note1: Whether it should be possible for the UTRAN to trigger a cell update request from the UE is FFS.]

8.3.565.9 RNTI reallocation

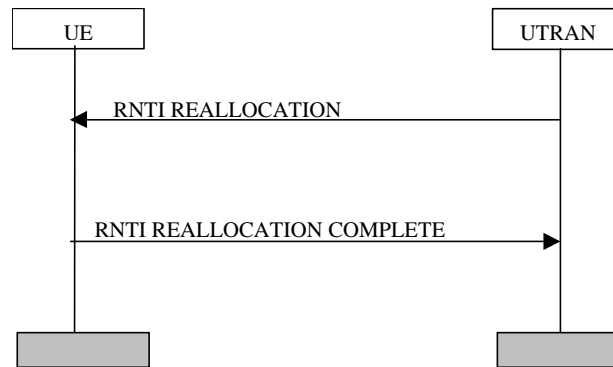

Figure 2523) RNTI reallocation procedure

This procedure is used by the network, to assign new Radio Network Temporary Identity (RNTI) information to a UE. It is initiated by the UTRAN ~~by the sending of, which sends an~~ RNTI REALLOCATION message. The RRC message contains new S-RNTI and SRNC identity, and/or a new C-RNTI. It may also contain new NAS system information.

The UE starts to use the new identities and returns an RNTI REALLOCATION COMPLETE message as confirmation.

8.3.67 RRC Connected mode procedures which use Paging

8.3.67.1 Core network originated paging

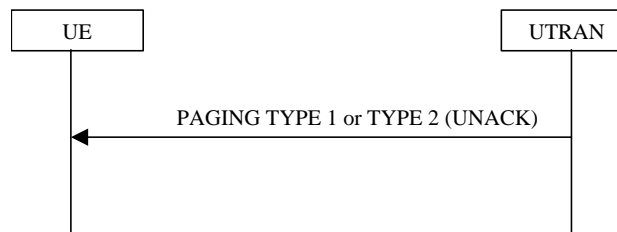

Figure 2624) Core network originated paging procedure in connected mode

So far only one example of this procedure has been identified (two others are FFS):

- UTRAN co-ordinates, UE is on DCCH (PAGING TYPE 2 message is used)
- UTRAN co-ordinates, UE is on PCCH (FFS, PAGING TYPE 1 message would be used)
- UE co-ordinates (FFS)

Consider case (a): This procedure enables the CN to request paging of a UE. Since the UE can be reached on the DCCH, the RRC layer formats a PAGING TYPE 2 message containing the UE paging identity and the NAS information, and the message is transmitted directly to the UE using unacknowledged data transfer.

[Note: It is FFS whether only one paging message is required (as used for idle mode paging) or whether both Type 1 and Type 2 paging messages are required]

8.3.67.2 UTRAN originated paging

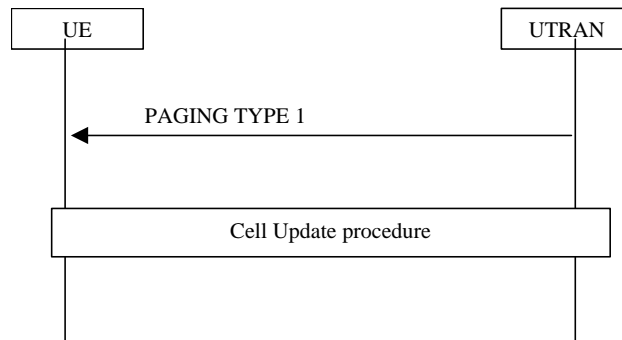

Figure 2725) UTRAN originated paging procedure in connected mode

The RRC layer in the network can use this procedure to trigger a switch from PCH or URA connected state to RACH/FACH or RACH+FAUSCH/FACH state. A PAGING TYPE 1 message, containing the S-RNTI and SRNC identity is sent on the PCCH.

In the UE, the RRC layer continuously monitors the paging group on the PCH and compares the UE identities in the received paging messages with its own identities. When a match occurs, the RRC layer uses the cell update procedure to acknowledge the reception of paging and optionally obtain a new C-RNTI.

[Note: It is FFS whether only one paging message is required (as used for idle mode paging) or whether Type 1 and Type 2 paging messages are also required]

8.3.787 Procedures related to measurement and monitoring

[Note: The following text needs to be reviewed at the next 3GPP WG2 meeting]

~~In idle mode, the UE monitors and measures neighboring cells according to information received on BCH.~~

~~After sending the initial random access message, the UE may continue measurements using the 'idle' mode parameters until a MEASUREMENT CONTROL message is received from the serving RNS. This message indicates the parameters to be used for monitoring in 'connected' state.~~

Monitored cells are grouped in the UE into ~~three~~two different categories:

1. Cells that belong to the **active set**. User information is sent from all these cells and they are simultaneously demodulated and coherently combined. These cells are involved in soft handover.
2. Cells that are ~~not included in the active set, but are identified as feasible for handover~~ monitored for handover belong to the **candidate monitored set**. ~~The UE may request that a cell in the candidate set is moved to the active set in a MEASUREMENT REPORT message.~~
3. ~~Other cells that are known, but not currently feasible for handover, belong to the neighbour set. The UE does not notify the serving RNS when it moves a cell from the candidate set to the neighbour set or from the neighbour set to the candidate set.~~

From an RRC point of view, the ~~mobile station UE~~ measurements can be grouped with respect to the type of measurement performed in the ~~mobile station UE~~, i.e., what ~~and how~~ the ~~mobile station UE~~ shall measure. Examples are:

~~—Radio link measurements: measurements on downlink radio links in the active set.~~

- Intra-frequency measurements: measurements on downlink physical channels with the same frequency as the active set, that do not belong to the active set, but have the same frequency as the active set.

- Inter-frequency measurements: measurements on downlink physical channels with frequencies that differ from the frequency of the active set.
- Inter-system measurements: measurements on downlink physical channels belonging to another radio access system than WCDMAUTRAN, e.g. PDC or GSM.
- Traffic volume measurements: measurements on uplink traffic volume.
- Quality measurements: Measurements of quality parameters, e.g. downlink transport block error rate.
- Internal measurements: Measurements of UE transmission power and UE received signal level.

The same type of measurements can be used as input to different functions in UTRAN. For instance, an intra-frequency A-radio link measurement in the mobile-station-UE can be used for handover, power control or operation and maintenance purposes in the network. However, it should be possible to have a number of mobile-station-UE measurements running in parallel, where each measurement is controlled and reported independently of each other.

Each type of mobile-station-UE measurement is associated with a standardised measurement method that can be described with a limited number of parameters (threshold levels, triggering conditions etc) in the measurement control message from the network.

~~The measurement control message to the mobile station can be sent using either acknowledged or unacknowledged data transfer (L2-LAC-C) on the DCCH. The acknowledged mode would be employed for critical control messages, e.g. inter-frequency measurements intended for handover. The unacknowledged mode may be used for less critical measurements, e.g. mobile station measurements intended for operation and maintenance purposes.~~

The measurement report to the network can ~~likewise~~ be sent by either acknowledged or unacknowledged data transfer on the DCCH. The acknowledged mode may be employed for e.g. event-triggered measurement reports, while the unacknowledged mode may be used for e.g. periodical reporting with low small periodicity. The network ~~can~~ indicates report in the mobile-station-UE measurement control message) which reporting alternative the mobile-station-UE should use for the corresponding measurement.

~~Elementary RRC procedures that are required for UE measurements, and UE measurement reporting to the UTRAN, are identified and described below. The procedures are used in connected mode.~~

After sending the initial random access message, the UE shall continue measurements performed in idle mode until a MEASUREMENT CONTROL message is received from UTRAN. This message indicates e.g. the parameters to be used for monitoring in connected mode.

On the DCH, the UE shall report radio link related measurements to the UTRAN with a MEASUREMENT REPORT message. In order to receive information for the establishment of immediate macrodiversity, the UTRAN may also request the UE to append radio link related measurement reports to the following messages sent on the RACH:

- RRC CONNECTION REQUEST sent to establish an RRC connection.
- RRC CONNECTION RE-ESTABLISHMENT REQUEST sent to re-establish an RRC connection.
- DIRECT TRANSFER sent uplink to establish a signalling connection.
- CELL UPDATE sent to respond to a UTRAN originated page.
- MEASUREMENT REPORT sent to report uplink traffic volume.

[NoteOTE: Whether or not measured results can be appended to other messages and in other scenarios is FFS.-]

8.3.7.18.3.78.1 Measurement control



Figure 2826) Measurement Control procedure

This procedure is initiated from the UTRAN side to control a measurement in a specific UE. The UTRAN sends a MEASUREMENT CONTROL message to the UE on the DCCH. The message includes the information that controls the UE measurement. Examples of such information are:

1. **Measurement type:** One of the types from a predefined list where each type describes what the UE shall measure.
2. **Measurement identity number:** A reference number that is used by the UTRAN at modification of the measurement and by the UE in the measurement report.
3. **Measurement command:** One out of three different measurement commands
 - Setup: Setup a new measurement.
 - Modify: Modify a previously specified measurement, e.g. change the reporting criteria.
 - Release: Stop a measurement and clear all information in the UE that are related to that measurement.
4. **Measurement objects:** The objects the UE shall measure on, and corresponding object information.
5. **Measurement quantity:** The quantity the UE shall measure. This also includes the filtering of the measurements.
6. **Report quantities:** The quantities the UE shall include in the report in addition to the quantities that are mandatory to report for the specific event.
- 6-7. **Measurement reporting criteria:** The triggering of the measurement report, e.g. periodical ~~or~~ event-triggered ~~or immediate~~ reporting. ~~This is also used to specify~~ ~~Here is also specified if whether~~ the measurement report should be transmitted using either acknowledged or unacknowledged data transfer on the DCCH.

[Editor's note: Details of how this procedure can make use of slotted mode operation is still under investigation.]

8.3.7.28.3.78.2 Measurement reporting



Figure 2927) Measurement Report procedure

The Measurement Report procedure is initiated from the UE side when the reporting criteria are met. The message is sent using either acknowledged or unacknowledged data transfer on the DCCH. The UE sends a MEASUREMENT REPORT message to the UTRAN that includes the measurement identity number and the measurement results measured values of the mandatory and optional report quantities that were defined in the corresponding MEASUREMENT CONTROL message ~~requested measurement objects~~.

[Note: UE measurement reports can be sent without a prior Measurement Control message, e.g. reports of measurements that are predefined in the standard or defined via system information.]

8.3.8 Other procedures in connected mode

8.3.8.1 Transmission of UE capability information

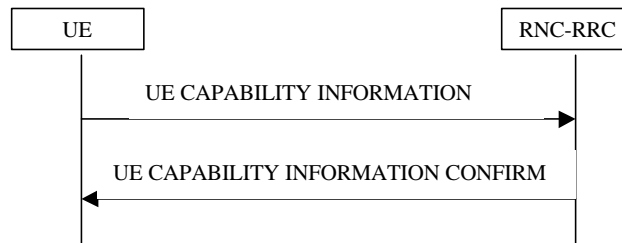

Figure 3028) Procedure for transmission of UE capability information

The UE transfers its capability information to the network by transmitting the UE CAPABILITY INFORMATION message on the DCCH. The UTRAN acknowledges the successful update of UE capability by a UE CAPABILITY INFORMATION CONFIRM message. This procedure can (optionally) be performed after RRC Connection Setup procedure and also during the lifetime of the RRC Connection if the UE capability information changes (e.g. due to change in UE power class). UE capability information can also be explicitly requested by the UTRAN [Note: The mechanism for this is FFS].

8.3.8.2 Sending of system information in RRC connected mode

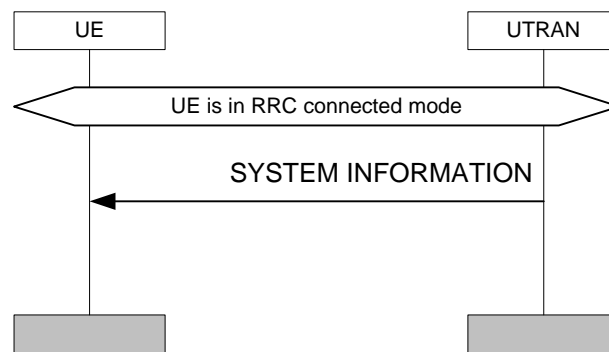

Figure 29) Figure 3129 Sending of system information to UE in RRC connected mode

This procedure is used to transfer system information from the network to all connected mode UEs in a cell. The UTRAN may send dedicated system information messages to the UE in RRC connected mode in order to update e.g. neighbouring cell and MM information. The UE RRC forwards received MM information to the UE MM sublayer. The system information messages transmitted in connected mode include different combinations of parameters than system information messages for idle mode MSs.

The grouping of system information blocks is FFS.

Three ways have been identified by which this signalling can be conveyed:

- On DCCH [Note: This is FFS. The DCCH might be used to send modified system information blocks directly to the UE.]

- On BCCH [*Editors note, the BCCH may be used to convey information to a UE even when a DCCH exists. ~~T~~ and the current assumption is that where a DCCH exists the BCCH is not used*]
- On CCCH mapped onto a FACH or a DSCH control ACCH transport channel (provided the DSCH control ACCH transport channel exists). [*Editors note, the CCCH may be used to convey information to a UE even when a DCCH exists*].

The UTRAN can ~~shall~~ notify the UE when system information blocks carried on the BCCH are modified. There are two ways to notify the UE:

- On PCCH. The message PAGING TYPE 1 ~~can~~ be sent to all UE's on the PCCH to indicate that the system information has been modified. The message includes the information element BCCH Modification Information.
- On CCCH. When system information is modified, the updated master information block ~~can~~ be broadcast on CCCH to all UEs listening to the FACH.

8.3.8.3 Direct transfer

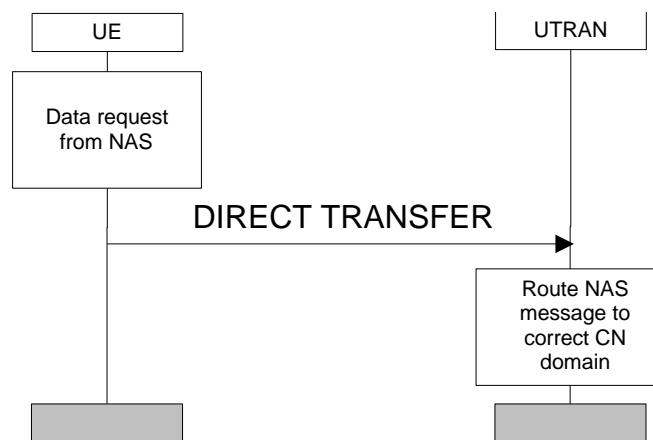

Figure 3230) Direct Transfer procedure in uplink

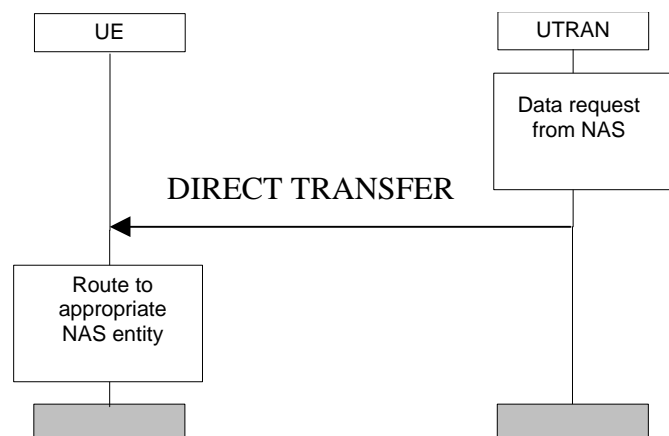

Figure 3331) Direct Transfer procedure in downlink

The direct transfer procedure is used to carry all higher layer (NAS) messages over the radio interface. The DIRECT TRANSFER message includes the higher layer (NAS) message as payload and a CN domain identifier of the destination (in uplink) or originating (in downlink) core network node.

The DIRECT TRANSFER message is used both in uplink and in downlink and is conveyed on a DCCH.

Upon reception of the DIRECT TRANSFER message the higher layer PDU is routed – using the CN domain identifier parameter – in UE side to correct higher layer entity and in UTRAN side to correct CN domain.

8.3.8.4 RRC status procedure

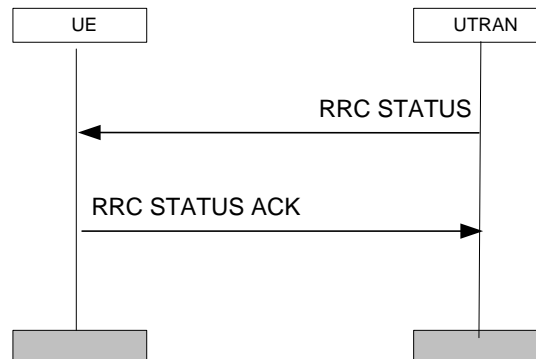

Figure 3432: RRC status procedure

[Note: The following describes the use of the RRC status procedure for release of signalling connection. Other use of this procedure is FFS.]

If a UE has signalling connections to CN1 and CN2, one of the nodes may request the UTRAN to release the RRC connection. In this case, without releasing the RRC connection the UTRAN needs to inform the corresponding MM entity in the UE ~~—without releasing the RRC connection—~~ that the signalling connection has been released, this is achieved using the RRC status procedure.

When the UTRAN receives a signalling connection release request from a core network node, it informs the UE of a signalling connection release with a RRC STATUS message. After receiving this message the UE RRC informs the corresponding UE MM entity of RRC connection release and sends a RRC STATUS ACK to the UTRAN. When the UTRAN receives the acknowledgement message, it confirms the release of signalling connection to the core network node.

8.3.8.5 UE Capability Enquiry

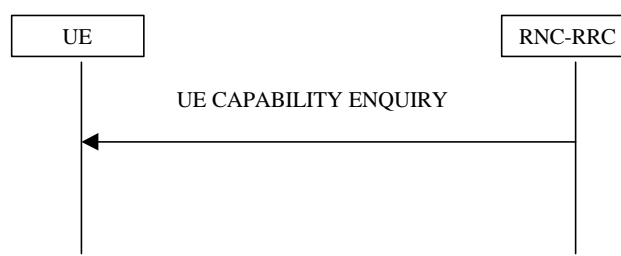

Figure 3533: UE capability Enquiry procedure.

UE Capability Enquiry can be used to request the UE to transmit its capability information related to any radio access network that is supported by the UE. In particular, it can be used by the UTRAN to request an update of GSM capability information from a GSM-UMTS dual mode terminal UE.

The UE CAPABILITY ENQUIRY message is transmitted on the DCCH and it includes an indication of the desired UE capability information (e.g., GSM Classmark N)

9 Primitives between RRC and upper layers

10 Message and information element functional definition and content

The function of each Radio Resource Control message together with message contents [in the form of a list of information elements](#) is defined in subclause 10.1.

[The functional definitions](#) of the [information elements](#) are [then](#) described in subclause 10.2.

Information elements are marked as either M- mandatory, O - Optional or C -conditional.

10.1 Radio Resource Control messages

10.1.1 RRC Connection Mobility Messages

10.1.1.1 ACTIVE SET UPDATE

<Functional description of this message to be included here>

RLC-SAP: t.b.d.

Logical channel: DCCH

Direction: UTRAN → UE

Information element category	Information elements	REFERENCE	TYPE	NOTE
	Message Type		M	
UE information elements	Activation time		O	
Phy CH information elements	Primary CCPCH info		M	Note 1 For each radio link to add
	SSDT cell identity		O	
	Downlink DPCH info		M	
	Primary CCPCH info		M	Note 1 For each radio link to delete
	SSDT indicator		O	

Note 1: If it is assumed that primary CCPCH downlink scrambling code is always allocated with sufficient reuse distances, primary CCPCH downlink scrambling code will be enough for designating the different radiolinks.

10.1.1.2 ACTIVE SET UPDATE COMPLETE

<Functional description of this message to be included here>

RLC-SAP: t.b.d.

Logical channel: DCCH

Direction: UE→UTRAN

Information element category	Information elements	REFERENCE	TYPE	NOTE
	Message Type		M	
Phy CH information elements	SSDT indicator		O	

10.1.1.3 CELL UPDATE

This message is used by the UE to initiate a cell update procedure.

RLC-SAP: t.b.d.

Logical channel: t.b.d.

Direction: UE→UTRAN

Information element category	Information elements	REFERENCE	TYPE	NOTE
	Message Type		M	
UE information elements	S-RNTI		M	FFS whether in RRC or MAC PDU.
	SRNC identity		M	
	Cell update cause		M	
Measurement information elements	Measurement identity number			Intra-frequency measurement related report (necessity is FFS)
	Measured results			

10.1.1.4 CELL UPDATE CONFIRM

This message confirms the cell update procedure and can be used to reallocate new RNTI information for the UE valid in the new cell.

RLC-SAP: t.b.d.

Logical channel: t.b.d.

Direction: UTRAN→UE

Information element category	Information elements	REFERENCE	TYPE	NOTE
	Message Type		M	
UE information elements	S-RNTI		M	FFS whether in RRC or MAC PDU.
	SRNC identity		M	
	S-RNTI		O	New S-RNTI
	SRNC identity		O	New SRNC identity
	C-RNTI		O	New C-RNTI
UTRAN mobility information elements	URA update indicator		O	When present, it instructs UE to make URA updating
	URA identifier		O	Indicates to the UE, which URA it shall use in case of overlapping URAs.
CN information elements	PLMN identity		O	(Note1,2)

	CN domain identity		O	For each CN domain (Note1,2)
	NAS system info		O	For each CN domain (Note1,2)
Physical CH information elements	Default DPCH Offset Value		O	FFS

[Note1: It depends on the length of these information whether this message can be used to notify these information to UE.]

[Note2: Necessity of PLMN is FFS and for CN domain identity and NAS system information, the confirmation in SA WG2 is needed.]

10.1.1.5 HANDOVER COMMAND

<Functional description of this message to be included here>

RLC-SAP: t.b.d.

Logical channel: DCCH

Direction: UTRAN → UE

Information element category	Information elements	REFERENCE	TYPE	NOTE	
	Message Type		M		
Phy CH information elements	Frequency info		M		
	UL DPCH power control info		M		
	UL DPCH info		M	Uplink radio resources	
	UL timeslot info		O		
	Primary CCPCH info		M	For each radio link. Note1	
	DL DPCH info		M		
	DL timeslot info		O		Note 2
	SSDT indicator		O		Downlink radio resources

Note1: The possibility to request the establishment of several radio links simultaneously with this message is FFS.

Note 2: It is assumed that the DL timeslot configuration is the same for all radio links, whether or not macro-diversity is supported for TDD.

10.1.1.6 HANDOVER COMPLETE

<Functional description of this message to be included here>

RLC-SAP: t.b.d.

Logical channel: DCCH

Direction: UE → UTRAN

Information element category	Information elements	REFERENCE	TYPE	NOTE
	Message Type		M	
Phy CH information elements	SSDT indicator		O	

10.1.1.7 INTER-SYSTEM HANDOVER COMMAND

This message is used for handover from UMTS to another system e.g. GSM. One or several messages from the other system can be included in the Inter-System message information element in this message. These messages are structured and coded according to that systems specification.

RLC-SAP: t.b.d.

Logical channel: DCCH

Direction: UTRAN→UE

Information element category	Information elements	REFERENCE	TYPE	NOTE
	Message Type		M	
UE information elements	Activation time		O	
Other information elements	Inter-System message		M	

10.1.1.8 INTER-SYSTEM HANDOVER FAILURE

This message is sent on the RRC connection used before the Inter-System Handover was executed. The message indicates that the UE has failed to seize the new channel in the other system.

RLC-SAP: t.b.d.

Logical channel: DCCH

Direction: UE→UTRAN

Information element category	Information elements	REFERENCE	TYPE	NOTE
	Message Type		M	
UE information elements	Inter-System handover failure cause		O	FFS
Other Information elements	Inter-System message		O	

10.1.1.9 URA UPDATE

This message is used by the UE to initiate a URA update procedure.

RLC-SAP: t.b.d.

Logical channel: t.b.d.

Direction: UE→UTRAN

Information element category	Information elements	REFERENCE	TYPE	NOTE
	Message Type		M	
UE information elements	S-RNTI		M	FFS whether in RRC or MAC PDU.
	SRNC identity		M	
	URA update cause		M	

10.1.1.10 URA UPDATE CONFIRM

<Functional description of this message to be included here> This message confirms the URA update procedure and can be used to reallocate new RNTI information for the UE valid after the URA update.
RLC-SAP: t.b.d.

Logical channel: t.b.d.

Direction: UTRAN→UE

Information element category	Information elements	REFERENCE	TYPE	NOTE
	Message Type		M	
UE information elements	S-RNTI		M	FFS whether in RRC or MAC PDU.
	SRNC identity		M	
	S-RNTI		O	New S-RNTI
	SRNC identity		O	New SRNC identity
	C-RNTI		O	New C-RNTI
UTRAN mobility information elements	URA identifier		O	Indicates to the UE, which URA it shall use in case of overlapping URAs.
CN information elements	PLMN identity		O	(Note1,2)
	CN domain identity		O	For each CN domain (Note1,2)
	NAS system info		O	For each CN domain (Note1,2)

[Note1: It depends on the length of these information whether this message can be used to notify these information to UE.]

[Note2: Necessity of PLMN is FFS and for CN domain identity and NAS system information, the confirmation in SA WG2 is needed.]

10.1.1.11 RNTI REALLOCATION

<Functional description of this message to be included here>

RLC-SAP: t.b.d.

Logical channel: t.b.d.

Direction: UTRAN→UE

Information element category	Information elements	REFERENCE	TYPE	NOTE
	Message Type		M	
UE information elements	S-RNTI		O	FFS whether in RRC or MAC PDU.
	SRNC identity		O	
	S-RNTI		O	New S-RNTI
	SRNC identity		O	New SRNC identity
	C-RNTI		O	New C-RNTI
CN information elements	PLMN identity		O	(Note1,2)
	CN domain identity		O	For each CN domain (Note1,2)
	NAS system info		O	For each CN domain (Note1,2)

[Note1: It depends on the length of these information whether this message can be used to notify these information to UE.]

[Note2: Necessity of PLMN is FFS and for CN domain identity and NAS system information, the confirmation in SA WG2 is needed.]

10.1.1.12 RNTI REALLOCATION COMPLETE

This message is used to confirm the new RNTI information for the UE.

RLC-SAP: t.b.d.

Logical channel: DCCH

Direction: UE→UTRAN

Information element category	Information elements	REFERENCE	TYPE	NOTE
	Message Type		M	

10.1.2 Measurement Messages

10.1.2.1 MEASUREMENT CONTROL

<Functional description of this message to be included here>

RLC-SAP: t.b.d.

Logical channel: DCCH

Direction: UTRAN→UE

Information element category	Information elements	REFERENCE	TYPE	NOTE	
	Message Type		M		
Measurement Information elements	Measurement Identity Number		M		
	Measurement Command		M		
	Measurement Type		O		
	Measurement Reporting Mode		O		
	Measurement Object	Intra-frequency cell info		C	If Measurement Type = Intra frequency measurement
		Inter-frequency cell info		C	If Measurement Type = Inter frequency measurement
		Inter-system cell info		C	If Measurement Type = Inter system measurement
		Traffic volume measurement object		C	If Measurement Type = Traffic volume measurement
		Quality measurement object		C	If Measurement Type = Quality measurement
	Measurement Quantity (Note1)	Intra-frequency measurement quantity		C	If Measurement Type = Intra frequency measurement
		Inter-frequency measurement quantity		C	If Measurement Type = Inter frequency measurement
		Inter-system measurement quantity		C	If Measurement Type = Inter system measurement
		Traffic volume measurement quantity		C	If Measurement Type = Traffic volume measurement
		Quality measurement quantity		C	If Measurement Type = Quality measurement
		UE Internal measurement quantity		C	If Measurement Type = UE Internal measurement
	Reporting quantity (Note2)	Intra-frequency measurement reporting quantity		O	If Measurement Type = Intra frequency measurement
		Inter-frequency measurement reporting quantity		O	If Measurement Type = Inter frequency measurement
		Inter-system measurement reporting quantity		O	If Measurement Type = Inter system measurement
		Traffic volume measurement reporting quantity		O	If Measurement Type = Traffic volume measurement
		Quality measurement reporting quantity		O	If Measurement Type = Quality measurement
		UE Internal measurement reporting quantity		O	If Measurement Type = UE Internal measurement
	Measurement Reporting Criteria (Note3)	Intra-frequency measurement reporting criteria		C	If Measurement Type = Intra frequency measurement

	Inter-frequency measurement reporting criteria		C	If Measurement Type = Inter frequency measurement
	Inter-system measurement reporting criteria		C	If Measurement Type = Inter system measurement
	Traffic volume measurement reporting criteria		C	If Measurement Type = Traffic volume measurement
	Quality measurement reporting criteria		C	If Measurement Type = Quality measurement
	UE Internal measurement reporting criteria		C	If Measurement Type = UE Internal measurement
	Periodical reporting criteria		C	

Note 1: Necessary only in event trigger reporting mode.

Note 2: It is FFS whether it is necessary to separate the reporting quantity for each type.

Note 3: Periodical reporting criteria is used only in periodical reporting mode and others are used in event trigger mode.

[Note 4: The network may order the UE to report other measurements when UE internal measurements are reported](#)

10.1.2.2 MEASUREMENT REPORT

<Functional description of this message to be included here>

RLC-SAP: t.b.d.

Logical channel: DCCH

Direction: UE→UTRAN

Information element category	Information elements	REFERENCE	TYPE	NOTE	
	Message Type		M		
Measurement Information elements	Measurement Identity Number		M	For each meas.rep. in this message (Note 1)	
	Event Result	Intra-frequency measurement event results			C
		Inter-frequency measurement event results			C
		Inter-system measurement event results			C
		Traffic volume measurement event results			C
		Quality measurement event results			C
	Measured Results		O	Necessary only when indicated optionally by Reporting Quantity in Measurement Control	

Note 1: If it is possible to send many measurement results that are identified by different measurement identity numbers in the same Measurement Report is FFS. An alternative solution is to admit only one measurement identity number per Measurement Report and concatenate different Measurement Reports in the RLC layer instead.

Note 2: If it is possible to send many measurement results that are identified by different events in the same Measurement Report is FFS.

10.1.3 Paging and Notification Messages

10.1.3.1 NOTIFICATION

<Functional description of this message to be included here>

RLC-SAP: t.b.d.

Logical channel: PCCH

Direction: UTRAN → UE

Information element category	Information elements	REFERENCE	TYPE	NOTE
	Message Type		M	

10.1.3.2 PAGING TYPE 1

This message is used to send information on the paging channel. One or several UEs, in idle or connected mode, can be paged in one message, which also can contain other information.

RLC-SAP: t.b.d.

Logical channel: PCCH

Direction: UTRAN → UE

Information element Category	RRC Information element	REFERENCE	TYPE	NOTE
	Message Type		M	
UE Information elements	Paging record		M	One paging record for each UE to be paged.
Other information elements	BCCH modification info		O	FFS

10.1.3.3 PAGING TYPE 2

This message is used to page an UE in connected mode, when using the DCCH for CN originated paging.

RLC-SAP: t.b.d.

Logical channel: DCCH

Direction: UTRAN → UE

Information element Category	RRC Information element	REFERENCE	TYPE	NOTE
	Message Type		M	
UE Information elements	CN domain identity		M	
	Paging cause		M	

10.1.4 RRC Connection Establishment and maintenance messages

10.1.4.1 RRC CONNECTION RE-ESTABLISHMENT

<Functional description of this message to be included here>

RLC-SAP: t.b.d.

Logical channel: t.b.d.

Direction: UTRAN → UE

Information element category	Information elements	REFERENCE	TYPE	NOTE
	Message Type		M	
Physical CH information elements	Default DPCH Offset Value		O	

10.1.4.2 RRC CONNECTION RE-ESTABLISHMENT COMPLETE

<Functional description of this message to be included here>

RLC-SAP: t.b.d.

Logical channel: DCCH

Direction: UE → UTRAN

Information element category	Information elements	REFERENCE	TYPE	NOTE
	Message Type		M	

10.1.4.3 RRC CONNECTION RE-ESTABLISHMENT REQUEST

<Functional description of this message to be included here>

RLC-SAP: t.b.d.

Logical channel: t.b.d.

Direction: UE → UTRAN

Information element category	Information elements	REFERENCE	TYPE	NOTE
	Message Type		M	
UE information elements	S-RNTI		M	FFS whether conveyed on RRC or MAC.
	SRNC identity		M	
Measurement information elements	Measurement identity number		M	Refers to system information. Note 1
	Measured results		M	
				For each measurement report

Note 1: The necessity and usage of Measurement identity number in this message is FFS.

10.1.4.4 RRC CONNECTION RELEASE

<Functional description of this message to be included here>

RLC-SAP: t.b.d.

Logical channel: DCCH

Direction: UTRAN→UE

Information element category	Information elements	REFERENCE	TYPE	NOTE
	Message Type		M	
UE information elements	Release cause		M	
	Number of Quick Repeat		M	

10.1.4.5 RRC CONNECTION RELEASE COMPLETE

<Functional description of this message to be included here>

RLC-SAP: t.b.d.

Logical channel: DCCH

Direction: UE → UTRAN

Information element category	Information elements	REFERENCE	TYPE	NOTE
	Message Type		M	

10.1.4.6 RRC CONNECTION REQUEST

RRC Connection Request is the first message transmitted by the UE when setting up an RRC Connection to the network.

RLC-SAP: t.b.d.

Logical channel: CCCH

Direction: UE → UTRAN

Information element category	Information elements	REFERENCE	TYPE	NOTE
	Message Type		M	
UE information elements	Initial UE identity		M	FFS whether conveyed on RRC or MAC.
	Establishment cause		M	
	Initial UE capability		O	Necessity is FFS
Measurement information elements	Measurement identity number		M	Refers to system information. Note 1
	Measured results		M	For each measurement report

Note 1: The necessity and usage of Measurement identity number in this message is FFS.

10.1.4.7 RRC CONNECTION SETUP

This message is used by the network to accept the establishment of an RRC connection for an UE, including assignment of signalling link information, transport channel information and optionally physical channel information.

RLC-SAP: t.b.d.

Logical channel: CCCH

Direction: UTRAN → UE

Information element category	Information elements	REFERENCE	TYPE	NOTE	
	Message Type		M		
UE information elements	Initial UE identity		M	FFS whether conveyed on RRC or MAC.	
	S-RNTI		M		
	SRNC identity		M		
	C-RNTI		O	Only if assigned to a common transport channel	
	Activation time		O		
RAB information elements	RAB identity		M	Indicates the signalling link	
	Signalling link type		M		
	RAB multiplexing info		M	For the signalling link	
TrCH information elements	TFCS		O	Uplink TFCS	
	TFCS		O	Downlink TFCS	
	TFC subset		O		
	Transport channel identity		M	For each new transport channel	Uplink transport channels
	TFS		M		
	Transport channel identity		M	For each new transport channel	Downlink transport channels
TFS		M			
PhyCH information elements	Frequency info		O		
	Uplink DPCH power control info		O		
	Uplink DPCH info		O	Maximum one of these	Uplink radio resources
	PRACH info		O		
	Uplink timeslot info		O		
	Primary CCPCH info		O	For each radio link	Downlink radio resources
	Downlink DPCH info		O		
	Secondary CCPCH info		O		
	Downlink timeslot info		O		
SSDT indicator		O		Necessity is FFS	
Gated Transmission Control info		O		FFS	
Default DPCH Offset Value			O		

Note 1: It is assumed that the DL timeslot configuration is the same for all radio links, whether or not macro-diversity is supported for TDD.

10.1.4.8x RRC CONNECTION SETUP COMPLETE

This message confirms the establishment of the RRC Connection by the UE.

RLC-SAP: t.b.d.

Logical channel: DCCH

Direction: UE → UTRAN

Information element category	Information elements	REFERENCE	TYPE	NOTE
	Message Type		M	
Phy CH information elements	SSDT indicator		O	Necessity is FFS

10.1.4.98 RRC CONNECTION REJECT

This message is transmitted by the network when the requested RRC connection cannot be accepted.

RLC-SAP: t.b.d.

Logical channel: CCCH

Direction: UTRAN → UE

Information element category	Information elements	REFERENCE	TYPE	NOTE
	Message Type		M	
UE information elements	Initial UE identity		M	FFS whether conveyed on RRC or MAC.
	Rejection cause		M	
	Wait time		O	

10.1.4.109 RRC STATUS

This message is transmitted by the network when the network requests UE to release one of several signalling connections.

RLC-SAP: t.b.d.

Logical channel: DCCH

Direction: UTRAN → UE

Information element category	Information elements	REFERENCE	TYPE	NOTE
	Message Type		M	
CN information elements	CN domain identity		M	

10.1.4.110 RRC STATUS ACK

This message is transmitted by UE as an acknowledgement for RRC STATUS message.

RLC-SAP: t.b.d.

Logical channel: DCCH

Direction: UE → UTRAN

Information element category	Information elements	REFERENCE	TYPE	NOTE
	Message Type		M	

10.1.5 Radio Access Bearer control messages

10.1.5.1 PHYSICAL CHANNEL RECONFIGURATION

This message is used by UTRAN to assign, replace or release a set of physical channels used by a UE.

RLC-SAP: t.b.d.

Logical channel: DCCH

Direction: UTRAN → UE

Information element category	Information elements	REFERENCE	TYPE	NOTE		
	Message Type		M			
UE Information elements	Activation time		O			
	C-RNTI		O	Only RACH/FACH		
UTRAN mobility Information elements	URA update indicator		O	When PCH shall be used, and when present, it instructs the UE to make URA updating		
PhyCH information elements	Uplink DPCH power control info		O			
	Frequency info		O			
	Uplink DPCH info		O	Maximum one of these		
	PRACH info		O			
	Uplink time slot info		O			
	Primary CCPCH info		O	For each radio link	Downlink radio resources	
	Downlink DPCH info		O			
	Secondary CCPCH info		O			For FACH
	Secondary CCPCH info		O			For PCH
	Downlink timeslot info		O	Note 1		
SSDT indicator		O		Necessity is FFS		
Gated Transmission Control info		O		FFS		
Default DPCH Offset Value			O			

Note 1: It is assumed that the DL timeslot configuration is the same for all radio links, whether or not macro-diversity is supported for TDD.

10.1.5.2 PHYSICAL CHANNEL RECONFIGURATION COMPLETE

This message is sent from the UE when a physical channel reconfiguration has been done.

RLC-SAP: t.b.d.

Logical channel: DCCH

Direction: UE → UTRAN

Information element category	Information elements	REFERENCE	TYPE	NOTE
	Message Type		M	
Phy CH information elements	SSDT indicator		O	Necessity is FFS

10.1.5.3 RADIO ACCESS BEARER RECONFIGURATION

This message is sent from UTRAN to reconfigure parameters related to a change of QoS. This procedure can also change the multiplexing of MAC, reconfigure transport channels and physical channels.

RLC-SAP: t.b.d.

Logical channel: DCCH

Direction: UTRAN → UE

Information element category	Information elements	REFERENCE	TYPE	NOTE	
	Message Type		M		
UE Information elements	Activation time		O		
	C-RNTI			Only RACH/FACH	
RAB information elements	RAB identity		M	For each RAB affected by this message	
	RLC info		O		FFS
	RAB multiplexing info		M		
TrCH information elements	TFCS		O	for uplink DCHs	
	TFCS		O	for downlink DCHs	
	TFC subset		O	for DCHs in uplink	
	Transport channel identity		O	For each removed transport channel	Uplink transport channels
	Transport channel identity		O	For each reconfigured or added transport channel	
	TFS		O		
	Dynamic Control		O	For each reconfigured or added transport channel controlled by DRAC	
	Transmission time validity		O		

	Time duration before retry		O		
	Silent period duration before release		O		
	Transport channel identity		O	For each removed transport channel	Downlink transport channels
	Transport channel identity		O	For each reconfigured or added transport channel	
	TFS		O		
PhyCH information elements	Uplink DPCH power control info		O		
	Frequency info		O		
	Uplink DPCH info		O	Maximum one of these	Uplink radio resources
	PRACH info		O		
	Uplink timeslot info		O		
	Primary CCPCH info		O	For each radio link	Downlink radio resources
	Downlink DPCH info		O		
	Secondary CCPCH info		O		
	Downlink timeslot info		O	Note 1	
	SSDT indicator		O	Necessity is FFS	
	Gated Transmission Control info		O	FFS	
Default DPCH Offset Value		O			

Note 1: It is assumed that the DL timeslot configuration is the same for all radio links, whether or not macro-diversity is supported for TDD.

10.1.5.4 RADIO ACCESS BEARER RECONFIGURATION COMPLETE

This message is sent from the UE when a RAB and signalling link reconfiguration has been done.
 RLC-SAP: t.b.d.
 Logical channel: DCCH
 Direction: UE → UTRAN

Information element category	Information elements	REFERENCE	TYPE	NOTE
	Message Type		M	
RAB information elements	RAB identity		M	For each reconfigured RAB
TrCH information elements	Transport channel identity		O	For each removed, reconfigured or added transport channel
Phy CH information elements	SSDT indicator		O	Necessity is FFS

10.1.5.5 RADIO ACCESS BEARER RELEASE

<Functional description of this message to be included here>

RLC-SAP: t.b.d.
 Logical channel: DCCH
 Direction: UTRAN → UE

Information element category	Information elements	REFERENCE	TYPE	NOTE	
	Message Type		M		
UE Information elements	Activation time		O		
	C-RNTI		O	Only RACH/FACH	
RAB information elements	RAB identity		M	For each released RAB	
	RAB identity		O	For each other RAB affected by this message	
	RAB multiplexing info		O		
TrCH information elements	TFCS		O	for uplink DCHs	
	TFCS		O	for downlink DCHs	
	TFC subset		O	for DCHs in uplink	
	Transport channel identity		O	For each removed transport channel	Uplink transport channels
	Transport channel identity		O	For each reconfigured or added (FFS) transport channel	
	TFS		O	For each reconfigured or added (FFS) transport channel	
	Dynamic Control		O	For each reconfigured or added (FFS) transport channel, controlled by DRAC	
	Transmission time validity		O		
	Time duration before retry		O		
	Silent period duration before release		O		
	Transport channel identity		O	For each removed transport channel	Downlink transport channels
	Transport channel identity		O	For each reconfigured or added transport channel	
	TFS		O		
PhyCH information elements	Uplink DPCH power control info		O		
	Frequency info		O		
	Uplink DPCH info		O	Maximum one of these	Uplink radio resources
	PRACH info		O		
	Uplink timeslot info		O		
	Primary CCPCH info		O	For each radio link	Downlink radio resources
	Downlink DPCH info		O		
	Secondary CCPCH info		O		
	Downlink timeslot info		O		

Note 1: It is assumed that the DL timeslot configuration is the same for all radio links, whether or not macro-diversity is supported for TDD.

10.1.5.6 RADIO ACCESS BEARER RELEASE COMPLETE

<Functional description of this message to be included here>

RLC-SAP: t.b.d.

Logical channel: DCCH

Direction: UE → UTRAN

Information element category	Information elements	REFERENCE	TYPE	NOTE
	Message Type		M	
RAB information elements	RAB identity		M	For each released RAB
TrCH information elements	Transport channel identity		O	For each removed, reconfigured or added transport channel

10.1.5.7 RADIO ACCESS BEARER SETUP

<Functional description of this message to be included here>

RLC-SAP: t.b.d.

Logical channel: DCCH

Direction: UTRAN → UE

Information element category	Information elements	REFERENCE	TYPE	NOTE	
	Message Type		M		
CN information elements	NAS binding info		M	Transparent non access stratum info e.g. bearer identity.	
	CN domain identity				
UE Information elements	Activation time		O		
	C-RNTI		O	Only RACH/FACH	
RAB information elements	RAB identity		M	For the new RAB	
	RLC info		M		
	RAB multiplexing info		M		
	RAB identity		O	For each other RAB affected by this message	
	RAB multiplexing info		O		
TrCH information elements	TFCS		O	for uplink DCHs	
	TFCS		O	for downlink DCHs	
	TFC subset		O	for DCHs in uplink	
	Transport channel identity		O	For each removed transport channel	Uplink transport channels
	Transport channel identity		O	For each reconfigured or added transport channel	
	TFS		O	For each reconfigured or added transport channel	
	Dynamic Control		O	For each reconfigured or added transport channel, controlled by DRAC	
	Transmission time validity		O		
	Time duration before retry		O		
	Silent period duration before release		O		
	Transport channel identity		O	For each removed (FFS) transport channel	Downlink transport channels
	Transport channel identity		O	For each reconfigured or added transport channel	
	TFS		O	For each reconfigured or added transport channel	
PhyCH information elements	Uplink DPCH power control info		O		
	Frequency info		O		
	Uplink DPCH info		O	Maximum one of these	Uplink radio resources
	PRACH info		O		
	Uplink timeslot info		O		
	Primary CCPCH info		O	For each radio link	Downlink radio resources
	Downlink DPCH info		O		
	Secondary CCPCH info		O	Note 1	
	Downlink timeslot info		O		
	SSDT indicator		O	Necessity is FFS	

	Gated Transmission Control info		O	FFS
	Default DPCH Offset Value		O	

Note 1: It is assumed that the DL timeslot configuration is the same for all radio links, whether or not macro-diversity is supported for TDD.

10.1.5.8 RADIO ACCESS BEARER SETUP COMPLETE

<Functional description of this message to be included here>

RLC-SAP: t.b.d.

Logical channel: DCCH

Direction: UE → UTRAN

Information element category	Information elements	REFERENCE	TYPE	NOTE
	Message Type		M	
RAB information elements	RAB identity		M	For each new RAB
TrCH information elements	Transport channel identity		O	For each removed, reconfigured or added transport channel
Phy CH information elements	SSDT indicator		O	Necessity is FFS

10.1.5.9 TRANSPORT CHANNEL RECONFIGURATION

This message is used by UTRAN to configure the transport channel of a UE. This also includes a possible reconfiguration of physical channels. The message can also be used to assign a TFC subset and reconfigure physical channel.

RLC-SAP: t.b.d.

Logical channel: DCCH

Direction: UTRAN → UE

Information element category	Information elements	REFERENCE	TYPE	NOTE	
	Message Type		M		
UE Information elements	Activation time		O		
	C-RNTI		O	Only RACH/FACH	
	Control-only-state-timer		O	FFS	
TrCH information elements	TFCS		O	for uplink DCHs	
	TFCS		O	for downlink DCHs	
	TFC subset		O	for DCHs in uplink	
	Transport channel identity		O	For each reconfigured transport channel	Uplink transport channels
	TFS		O		
	Dynamic Control		O		
	Transmission time validity		O		
	Time duration before retry		O		
	Silent period duration before release		O		
	Transport channel identity		O	For each reconfigured transport channel	Downlink transport channels
	TFS		O		
PhyCH information elements	Uplink DPCH power control info		O		
	Frequency info		O		
	Uplink DPCH info		O	Maximum one of these	Uplink radio resources
	PRACH info		O		
	Uplink timeslot info		O		
	Primary CCPCH info		O	For each radio link	Downlink radio resources
	Downlink DPCH info		O		
	Secondary CCPCH info		O		
	Downlink timeslot info		O		
	SSDT indicator		O	Necessity is FFS	
	Gated Transmission Control info		O	FFS	
	Default DPCH Offset Value		O		

Note 1: It is assumed that the DL timeslot configuration is the same for all radio links, whether or not macro-diversity is supported for TDD.

10.1.5.10 TRANSPORT CHANNEL RECONFIGURATION COMPLETE

This message is sent from the UE when a transport channel reconfiguration has been done.

RLC-SAP: t.b.d.

Logical channel: DCCH

Direction: UE → UTRAN

Information element category	Information elements	REFERENCE	TYPE	NOTE
	Message Type		M	
TrCH information elements	Transport channel identity		M	For each reconfigured transport channel
Phy CH information elements	SSDT indicator		O	Necessity is FFS

Note: The usage of this message for indicating the cell the UE will select in the DCH->RACH/FACH case, is FFS.

10.1.5.11 TRANSPORT FORMAT COMBINATION CONTROL

<Functional description of this message to be included here>

RLC-SAP: t.b.d.

Logical channel: DCCH

Direction: UTRAN→UE

Information element category	Information elements	REFERENCE	TYPE	NOTE
	Message Type		M	
TrCH information elements	TFC subset		M	for DCHs in UL

10.1.6 System Information Messages

10.1.6.1 SYSTEM INFORMATION

<Functional description of this message to be included here>

RLC-SAP: t.b.d.

Logical channel: BCCH or DCCH or CCCH

Direction: UTRAN → UE

NOTE: The division of the system information into messages is FFS.

Information element category	Information elements	REFERENCE	TYPE	NOTE
	Message Type		M	
CN information elements	PLMN Identity		M	
	CN domain identity		M	For each Core Network Domain. Information must be included for at least one core network domain type.
	NAS system information		M	
UTRAN mobility information elements	URA identity		M	For each URA
	Information for periodic cell and URA update		M	<i>Note: not for each URA any more</i>
	Cell identity		M	The necessity and usage of cell identity is FFS.
	Cell selection and re-selection info		M	
UE information elements	Uplink access control info		M	
	Transmission probability		O	For all UE having DCH controlled by DRAC procedure For each class of UE Note2
	Maximum bit rate		O	
PhyCH information elements	Frequency info		O	For each RACH
	PRACH info		M	
	Frequency info		O	For each FACH on secondary CCPCH
	Secondary CCPCH info		M	
	Frequency info		O	For each PCH on secondary CCPCH
	Secondary CCPCH info		M	
	PRACH power control info		M	
Measurement Information elements	Measurement Identity Number		M	Note 1
	Intra-frequency cell info		M	For each measurement object
	Intra-frequency measurement quantity		M	
	Intra-frequency measurement reporting criteria		M	
	Intra-frequency reporting quantity for RACH reporting		C	Only included if RACH reporting is indicated in the reporting criteria

Measurement Identity Number		M	Note 1	For each Inter-frequency measurement control
Inter-frequency cell info		M	For each measurement object	
Inter-frequency measurement quantity		M		
Inter-frequency measurement reporting criteria		M		
Measurement Identity Number		M	Note 1	
Inter-system cell info		M	For each measurement object	For each Inter-system measurement control
Inter-system measurement quantity		M		
Inter-system measurement reporting criteria		M		
Measurement Identity Number		M	Note 1	

Note 1: The necessity and usage of Measurement identity number in this message is FFS.

Note 2: The split of parameters into several System Information message X is FFS.

10.1.7 Other Messages

10.1.7.1 UE CAPABILITY INFORMATION

<Functional description of this message to be included here>

RLC-SAP: t.b.d.

Logical channel: DCCH

Direction: UE → UTRAN

Information element category	Information elements	REFERENCE	TYPE	NOTE
	Message Type		M	
CN information elements	NAS message		M	Includes the CN capability information
UE information elements	Power control capability		M	UTRAN capability information
	Code resource capability		M	
	UE mode capability		M	
	Transport CH support capability		O	
	Ciphering capability		M	
	Macro diversity capability		M	
Other information elements	Inter-system message		O	Includes inter-system classmark

Note: The WG1 and WG4 discussion should be concluded before the contents of this message can be finalized.

10.1.7.2 UE CAPABILITY INFORMATION CONFIRM

<Functional description of this message to be included here>

RLC-SAP: t.b.d.

Logical channel: DCCH

Direction: UTRAN → UE

Information element category	Information elements	REFERENCE	TYPE	NOTE
	Message Type		M	

10.1.7.3 DIRECT TRANSFER

<Functional description of this message to be included here>

RLC-SAP: t.b.d.

Logical channel: DCCH

Direction: both

Information element category	Information elements	REFERENCE	TYPE	NOTE
	Message Type		M	
CN information elements	CN domain identity		M	
	NAS message		M	
Measurement information elements	Measured results		<u>O</u>	Intra-frequency measurement related report

10.2 Information element functional definitions

10.2.1 CN Information elements

10.2.1.1 CN domain identity

Points out the core network domain (e.g. IP or PSTN/ISDN CN domain).

10.2.1.2 NAS binding info

A field with non-access stratum information to bind a RAB to the non-access stratum. This information is transparent to RRC.

10.2.1.3 NAS message

A non-access stratum message to be transferred transparently through UTRAN.

10.2.1.4 NAS system information

System information that belongs to the non-access stratum (e.g. LAC, RA code etc). This information is transparent to RRC.

10.2.1.5 PLMN identity

Parameters	REFERENCE	TYPE	NOTE
MCC, Mobile Country Code		M	
MNC, Mobile Network Code		M	

10.2.2 UTRAN mobility Information elements

10.2.2.1 Cell identity

Identity of a cell within a PLMN.

Note: The necessity and usage of this information element is FFS.

10.2.2.2 Cell selection and re-selection info

Parameters	REFERENCE	TYPE	NOTE
Standby allowed reception level (dBm)		M	The usage of these parameters needs clarification FFS.
Standby prohibited reception level (dBm)		M	
Threshold for Cell Re-selection (dB)		M	
Allowed reception SIR (dB)		M	
Radio link timeout			

10.2.2.3 Information for periodic cell and URA update

FFS.

10.2.2.4 URA identity

Identity of the UTRAN Registration Area.

10.2.2.5 URA update indicator

When present in a message, it instructs the UE to start to update its location on URA level.

10.2.3 UE Information elements

10.2.3.1 Uplink access control info

Parameters	REFERENCE	TYPE	NOTE
Access class		M	FFS
Dynamic persistence level		M	FFS

10.2.3.2 C-RNTI

The controlling RNC RNTI identifies an UE having a RRC connection within an controlling RNC.

10.2.3.3 S-RNTI

The serving RNC RNTI is allocated to an UE having a RRC connection and identifies the UE within its serving RNC.

10.2.3.4 SRNC identity

Identifies the serving RNC for an UE having an RRC connection.

10.2.3.5 Initial UE identity

This information element identifies the UE at a request of an RRC connection.

Parameters	REFERENCE	TYPE	NOTE
IMSI		O	International Mobile Subscriber Identity
TMSI + LAI		O	Temporary Mobile Subscriber Identity and Location Area Identity
P-TMSI + RAI		O	Packet Temporary Mobile Subscriber Identity and Routing Area Identity
IMEI		O	International Mobile Subscriber Identity

[Note: The use of these identities is pending confirmation from WG1 that the RACH can support the required payload when these types of ID are used]

10.2.3.6 Activation time

Activation Time defines the frame number (or offset to some known frame number) in which the operation/changes caused by the related message should be executed.

Current assumption is that a connection based CFN (Connection Frame Number) that is known by MS and SRNC could be used.

10.2.3.7 Wait time

Wait time defines the time period the UE has to wait before repeating the rejected procedure.

10.2.3.8 Control-only-state timer

This IE indicates for how long the UE shall stay in the control-only-state. *Editors note: the exact usage of this IE needs some clarification.*

10.2.3.9 Paging record

Parameters	REFERENCE	TYPE	NOTE
Paging originator		M	UTRAN/CN
Paging cause		C	For CN originated pages
CN domain identity			
IMSI		O	International Mobile Subscriber Identity
TMSI		O	Temporary Mobile Subscriber Identity
P-TMSI		O	Packet Temporary Mobile Subscriber Identity
S-RNTI		O	For connected mode pages
SRNC identity			

10.2.3.10 Establishment cause

Cause for an RRC connection establishment request (originating call, emergency call, paging response, location update request, forward inter-system handover etc).

10.2.3.11 Release cause

Cause for release of RRC connection.

10.2.3.12 Rejection cause

Cause for rejection of RRC connection establishment request.

10.2.3.13 Paging cause

Cause for a CN originated page. *Editors note: The usage of this IE needs further clarification.*

10.2.3.14 Initial UE capability

This is the UE capability information given in the RRC connection request message. The exact type of information is FFS.

10.2.3.15 Power control capability

Parameters	REFERENCE	TYPE	NOTE
Transmission power capability		M	

Note: The WG1 and WG4 discussion should be concluded before the contents of this IE can be finalized.

10.2.3.16 Code resource capability

Parameters	REFERENCE	TYPE	NOTE
DL multi-code capability			
UL multi-code capability			
DL Spreading factor capability			
UL Spreading factor capability			

Note: The WG1 and WG4 discussion should be concluded before the contents of this IE can be finalized.

10.2.3.17 UE mode capability

Parameters	REFERENCE	TYPE	NOTE
System capability (UMTS/GSM/others)			
UMTS capability (TDD/FDD)			
Chip rate capability			
Radio Frequency capability			
Variable duplex distance capability			

Note: The WG1 and WG4 discussion should be concluded before the contents of this IE can be finalized.

10.2.3.18 Transport channel support capability

Parameters	REFERENCE	TYPE	NOTE
Maximum number of DCHs			
Support for Transport CH			

Note: The WG1 and WG4 discussion should be concluded before the contents of this IE can be finalized.

10.2.3.19 Cipherring capability

Parameters	REFERENCE	TYPE	NOTE
Cipherring Algorithm capability		M	

Note: The WG1 and WG4 discussion should be concluded before the contents of this IE can be finalized.

10.2.3.20 Macro diversity capability

Parameters	REFERENCE	TYPE	NOTE
Maximum number of RLs		M	

Note: The WG1 and WG4 discussion should be concluded before the contents of this IE can be finalized.

10.2.3.21 Cell update cause

Indicates the cause for s cell update. Examples of causes are cell reselection and periodic cell update.

10.2.3.22 URA update cause

Indicates the cause for s URA update. Examples of causes are change of URA and periodic URA update.

10.2.3.23 Number of Quick Repeat

Indicates the number of quick repeat for RRC Connection Release Complete message.

10.2.3.24 Inter-system handover failure cause

The purpose of this IE is to provide a reason for the failure of the Inter-system handover.

10.2.3.25 Transmission probability

Indicates the probability for a mobile to be allowed to transmit on a DCH controlled by DRAC procedure.

10.2.3.26 Maximum bit rate

Indicates the maximum user bit rate allowed on a DCH controlled by DRAC procedure for the transmission period (Transmission time validity).

10.2.3.27 Capability Update Requirement

This IE indicates to the UE, which is capable of inter-system handover, whether it should send a complete update of its capabilities in the given system (e.g. GSM) immediately after having established an RRC connection.

Parameters	REFERENCE	TYPE	NOTE
System		M	E.g. GSM
Early Capability Update		M	Yes / No

3.3.

10.2.4 Radio Access Bearer Information elements

10.2.4.1 RAB identity

An identification number for the RAB affected by a certain message.

10.2.4.2 RLC info

Parameters	REFERENCE	TYPE	NOTE	
RLC mode		M	Indicates if the RLC entity for a certain RAB should use Acknowledged, Non Acknowledged or Transparent mode data transfer. [Note: It is FFS if this parameter always is the same in both UL and DL.]	Uplink RLC info
RLC in-sequence delivery		O	Indication if RLC should preserve the order of higher layer PDUs that were transmitted through RLC. [Note: It is FFS if this parameter always is the same in both UL and DL.]	
RLC PDU size		C	Size of RLC Protocol Data Units. See Note 1	
RLC transmission window size		O	A flow control parameter used to set the maximum number of RLC PDUs sent without getting them acknowledged	
RLC retransmission info		M	This could be the number of attempts to retransmit a RLC PDU before it is discarded, or different timer values.	
RLC mode		M		Downlink RLC info
RLC in-sequence delivery		O		
RLC PDU Size		M	Note 1	
RLC transmission window size		O		
RLC retransmission info		O	Is this needed to send to the UE for downlink?	

Note1: RLC PDU size may be derived from transport block size and not explicitly transferred across the radio interface.

10.2.4.3 Signalling link type

The purpose of the Signalling Link Type information element is to indicate the RLC parameters needed for the signalling link.

Each possible value of Signalling Link Type information element refers to a predefined set of parameters. Details FFS.

10.2.4.4 RAB multiplexing info

A multiplexing option for each possible transport channel this RAB can be multiplexed on.

Parameters	REFERENCE	TYPE	NOTE		
Transport channel identity		O	This is the ID of a transport channel that this RAB could be mapped onto.	Uplink multi-plexing	For each multi-plexing option
Logical channel identity		O	This parameter is used to distinguish logical channels multiplexed by MAC on a transport channel.		
MAC logical channel priority		O	This includes both priority between different users traffic when using a common or shared channel, and between different RABs (or logical channels) traffic for a certain user. Different priorities for one users' RABs are mapped (through the MAC's T and C/T MUXes) to the TFC selection algorithm. <i>[Note: Usage and precise meaning of this is FFS.]</i>		
Transport channel identity		O		Downlink multi-plexing	
Logical channel identity		O			

Note: The necessity of dividing RAB multiplexing into in uplink and downlink is FFS.

10.2.5 Transport CH Information elements

10.2.5.1 Transport Format Combination Set

Indicates the allowed combinations of already defined Transport formats.

10.2.5.2 Transport Format Combination Subset

Indicates which Transport format combinations in the already defined Transport format combination set that are allowed.

10.2.5.3 Transport channel identity

This information element is used to distinguish transport channels (both common and dedicated transport channels).

10.2.5.4 Transport Format Set (TFS)

Parameters	REFERENCE	TYPE	NOTE
Transport block size(s)			(dynamic)
Transport Block Set Size(s)			(dynamic)
Transmission time interval			(semi-static)
Type of channel coding			(semi-static)
Rate matching			(semi-static)

10.2.5.5 Dynamic Control

Indicates if this transport channel is controlled by DRAC procedure or not.

10.2.5.6 Transmission time validity

Indicates the duration for which permission is granted on a DCH controlled by DRAC procedure.

10.2.5.7 Time duration before retry

Indicates the time duration before retrying to get the transmission permission on a DCH controlled by DRAC procedure, in case permission has not been granted.

10.2.5.8 Silent period duration before release

Indicates the maximum silent period duration before releasing the resource. This parameter may be merged with the Fkp-b parameter defined in the ‘Transmission stop and resumption control’ procedure defined in [1].

(Note: [1] RAN/WG1 S1.14 document)

10.2.6 Physical CH Information elements

10.2.6.1 Frequency info

Parameters	REFERENCE	TYPE	NOTE
Frequency number		M	Designate the centerfrequency of the uplink carrier
Duplex distance		O	
Chip rate		O	
Mode		O	Designate FDD or TDD mode

10.2.6.2 Primary CCPCH info

Parameters	REFERENCE	TYPE	NOTE
DL scrambling code		M	DL scrambling code used for Primary CCPCH

10.2.6.3 Secondary CCPCH info

Parameters	REFERENCE	TYPE	NOTE
DL scrambling code		O	Only needed if different from DL scrambling code of Primary CCPCH
Channelization code		M	

10.2.6.4 PRACH info

Parameters	REFERENCE	TYPE	NOTE
Access slot		M	For each allowed access slot for the preambles
Preamble spreading code		M	For each code to use for spreading of the preamble. There is also a one to one mapping from preamble code to what scrambling code to use for the message part.
Preamble signature		M	For each allowed preamble signature.
Spreading factor		M	For each rate or SF that are allowed to use on the data part (I-branch) in the message part of the random access

10.2.6.5 PRACH power control info

Parameters	REFERENCE	TYPE	NOTE
UL target SIR		M	<i>The usage of these parameters needs clarification and are also dependent on the WG1 RACH discussions.</i>
Primary CCPCH DL TX power		M	
UL interference		M	
Constant value		M	<i>Note: it should be clarified from WG1 whether this is the same as UL target SIR.</i>
<u>AICH transmission timing parameter</u>		M	
<u>Power offset ΔP_0</u>		M	<i>Power step when no acquisition indicator is received</i>
<u>Power offset ΔP_1</u>		M	<i>Power step when negative acquisition is received</i>

NOTE: The usage of these parameters needs clarification and are also dependent on the WG1 RACH discussions.

10.2.6.6 Uplink DPCH info

Parameters	REFERENCE	TYPE	NOTE
UL scrambling code		M	What short or long uplink scrambling code a certain UE should use
DPCCH channelization code		M	SF of the channelization code for control part. <i>[The necessity of this parameter is FFS.]</i>
DPDCH channelization code		M	SF of the channelization code for data part For each DPDCH

10.2.6.7 Uplink DPCH power control info

Interference level measured for a frequency at the UTRAN access point used by UE to set DPCH initial output power.

10.2.6.8 Downlink DPCH info

Parameters	REFERENCE	TYPE	NOTE
DL scrambling code		O	Only needed if different from DL scrambling code of Primary CCPCH
DL channelization code		M	Channelization codes to be used in the downlink for DPCH
			For each DPCH

10.2.6.9 Uplink timeslot info

Parameters	REFERENCE	TYPE	NOTE
Slot number		M	Timeslot to be used in uplink (TDD only)
			For each slot

10.2.6.10 Downlink timeslot info

Parameters	REFERENCE	TYPE	NOTE
Slot number		M	Timeslot to be used in downlink (TDD only)
			For each slot

10.2.6.11 SSdT indicator

This information element indicates the status (e.g. initiated/terminated) of the Site Selection Diversity Transmit power control (SSdT). In the direction UTRAN to UE it is used to change the SSdT status. In the direction UE to UTRAN it is used to confirm the SSdT status by the UE. [The parameter 'code word set' indicates how cell identities are coded \(using many bits or few, values are long, medium, or short\).](#)

Parameters	REFERENCE	TYPE	NOTE
Code Word Set		M	Values: long, medium, short, SSdT off

[10.2.6.12 SSdT cell identity](#)

[This IE is used to associate a cell identity with a given radio link](#)

Parameters	REFERENCE	TYPE	NOTE
temporary id		M	

10.2.6.132 Gated Transmission Control info (FFS)

Parameters	REFERENCE	TYPE	NOTE
Gating pattern		M	Indicates periodical or random (FFS)
Gating rate		M	Indicates no gating, 1/2 gating, 1/4 gating or 1/8 gating (FFS)
Gating activation time		M	FFS

[10.2.6.14 Default DPCH Offset Value](#)

Indicates the default offset value within interleaving size at a resolution of 512chip (1/5 slot) to offset CFN in the UE. This is used to distribute discontinuous transmission periods in time and also to distribute NodeB-RNC transmission traffics in time. Even though the CFN is offset by DOFF, the start timing of the interleaving will be the timing that “CFN mod (interleaving size)”=0 (e.g. interleaving size: 2,4,8) in both UE and SRNC.

10.2.7 Measurement Information elements

10.2.7.1 Measurement Identity Number

A reference number that is used by the UTRAN at modification and release of the measurement, and by the UE in the measurement report.

10.2.7.2 Measurement Command

One out of three different measurement commands

- Setup: Setup a new measurement.
- Modify: Modify a previously specified measurement, e.g. change the reporting criteria.
- Release: Stop a measurement and clear all information in the UE that are related to that measurement.

10.2.7.3 Measurement Type

One of the types from a predefined list where each type describes what the UE shall measure. The types are:

- Intra-frequency measurements
- Inter-frequency measurements
- Inter-system measurements
- Traffic volume measurements
- Quality measurements

10.2.7.4 Reference time difference to cell

The reference time difference to cell indicates the time difference between the primary CCPCH of the current cell and the primary CCPCH of a neighbouring cell. It is notified to UE by System Information or Measurement Control message.

In case of macro-diversity the reference is the primary CCPCH of one the cells used in the active set.

Editors note: Exactly how the reference cell is pointed out in this case in the messages is FFS.

10.2.7.5 Measured time difference to cell

~~The measured time difference to cell indicates the time difference which is measured by UE between the primary CCPCH of the current cell and the primary CCPCH of a neighbouring cell. It is notified to SRNC by Measurement Report message or Measurement Information Element in other RRC messages.~~

~~In case of macro-diversity the reference is the primary CCPCH of one the cells used in the active set.~~

~~The measured time difference to cell indicates the time difference which is measured by UE between CFN in the UE and the SFN of the target neighbouring cell. It is notified to SRNC by Measurement Report message or Measurement Information Element in other RRC messages.~~

~~*Editors note: Exactly how the reference cell is pointed out in this case in the messages is FFS.*~~

10.2.7.6 Measurement reporting mode

Contains the type of Measurement Report transfer mode and the indication of periodical/event trigger.

Parameters	REFERENCE	TYPE	NOTE
Measurement Report Transfer Mode		M	Acknowledged / Unacknowledged
Periodical Reporting / Event Trigger Reporting Mode		M	Periodical reporting / Event trigger

10.2.7.7 Intra-frequency cell info

Contains the measurement object information for an intra-frequency measurement.

<i>Parameters</i>	<i>REFERENCE</i>	<i>TYPE</i>	<i>NOTE</i>
Primary CCPCH info		M	
Primary CCPCH DL TX power		O	
UL load		O	FFS
Reference time difference to cell		O	
SFN Measurement Indicator		M	

10.2.7.8 Inter-frequency cell info

Contains the measurement object information for an inter-frequency measurement.

Parameters	REFERENCE	TYPE	NOTE
Frequency info		M	
Primary CCPCH info		M	
Primary CCPCH DL TX power		O	FFS
UL load		O	FFS
Reference time difference to cell		O	FFS

10.2.7.9 Inter-system cell info

Contains the measurement object information for an inter-system measurement.

Parameters	REFERENCE	TYPE	NOTE
System type		M	E.g. GSM
System specific measurement info			E.g frequency, timeslot, colour code, output power.

10.2.7.10 Traffic volume measurement object

Contains the measurement object information for a traffic volume measurement.

Parameters	REFERENCE	TYPE	NOTE
Target Transport CH ID		M	

10.2.7.11 Quality measurement object (FFS)

(Note: Only the section is made.)

10.2.7.12 Intra-frequency measurement quantity

The quantity the UE shall measure in case of intra-frequency measurement. It also includes the filtering of the measurements.

Parameters	REFERENCE	TYPE	NOTE	
Primary CCPCH RX E_c/I_0		O	One of these is mandatory	
Primary CCPCH RX SIR (RSCP/ISCP)		O		FFS
Primary CCPCH RX power (RSCP)		O		FFS
Path loss		O		FFS
Path loss plus UL load		O		FFS

(Note: Above measurements except for E_c/I_0 are not concluded in WG1)

10.2.7.13 Inter-frequency measurement quantity (FFS)

The quantity the UE shall measure in case of inter-frequency measurement. It also includes the filtering of the measurements.

Parameters	REFERENCE	TYPE	NOTE	
E_c/I_0		O	One of these is mandatory	
DL Path loss		O		FFS
SIR		O		FFS
DL path loss plus UL interference		O		FFS
Received signal code power (RSCP)		O		FFS

10.2.7.14 Inter-system measurement quantity (FFS)

The quantity the UE shall measure in case of inter-system measurement. It also includes the filtering of the measurements.

Parameters	REFERENCE	TYPE	NOTE
E_c/I_0		O	One of these is mandatory
Signal strength		O	
Path loss		O	
Colour code		M	GSM only

10.2.7.15 Traffic volume measurement quantity

Contains the measurement quantity information for a traffic volume measurement.

Parameters	REFERENCE	TYPE	NOTE
RLC buffer payload		M	

(Note: If there is no other measurement quantity, this parameter can be removed since it can be implicitly known by UE.)

[10.2.7.16 UE internal measurement quantity](#)

[The quantity the UE shall measure in case of UE internal measurement.](#)

Parameters	REFERENCE	TYPE	NOTE
UE Tx power		O	One of these is mandatory
UE RSSI		O	

10.2.7.176 Quality measurement quantity (FFS)

(Note: Only the section is made.)

10.2.7.187 Intra-frequency reporting quantity

Contains the reporting quantity information for an intra-frequency measurement.

Parameters	REFERENCE	TYPE	NOTE
Primary CCPCH RX E_c/I_0		O	
Primary CCPCH RX SIR (RSCP/ISCP)		O	FFS
Primary CCPCH RX power (RSCP)		O	FFS
Path loss		O	FFS
Path loss plus UL load		O	FFS
Measured time difference to cell		O	
DL Transport CH BLER		O	
DL Transport CH BER		O	FFS
UE Transmission Power		O	
UE Position		O	
Cell ID		O	FFS

(Note: It is FFS whether the reporting quantity parameters used in different measurement types can be used commonly for all types of reporting quantity. If they can, only "Reporting Quantity" is enough instead of specifying 5 types of reporting quantity.)

10.2.7.19x Intra-frequency reporting quantity for RACH reporting

Contains the reporting quantity information for an intra-frequency measurement report, which is sent on the RACH.

Parameters	REFERENCE	TYPE	NOTE
Primary CCPCH RX E_c/I_0		O	
Primary CCPCH RX SIR (RSCP/ISCP)		O	FFS
Primary CCPCH RX power (RSCP)		O	FFS
Path loss plus UL load		O	FFS
Measured time difference to cell		O	
DL Transport CH BLER		O	FFS
DL Transport CH BER		O	FFS
UE Transmission Power		O	FFS
UE Position		O	FFS
Cell ID		O	FFS

10.2.7.2048 Inter-frequency reporting quantity (FFS)

(Note: Only the section is made.)

10.2.7.2149 Inter-system reporting quantity (FFS)

(Note: Only the section is made.)

10.2.7.220 Traffic volume reporting quantity

Contains the reporting quantity information for a traffic volume measurement.

Parameters	REFERENCE	TYPE	NOTE
RLC buffer payload for each RAB		O	
DL Transport CH BLER		O	
DL Transport CH BER		O	FFS
UE Transmission Power		O	
UE Position		O	
Cell ID		O	FFS

(Note: It is FFS whether the reporting quantity parameters used in different measurement types can be used commonly for all types of reporting quantity. If they can, only "Reporting Quantity" is enough instead of specifying 5 types of reporting quantity.

10.2.7.234 Quality reporting quantity (FFS)

(Note: Only the section is made.)

10.2.7.242 Intra-frequency measurement reporting criteria

The triggering of the event-triggered reporting for an intra-frequency measurement. All events concerning intra-frequency measurements are labeled 1x where x is a, b, c....

Event 1a: A Primary CCPCH enters the Reporting Range [Note1]

Event 1b: A Primary CCPCH leaves the Reporting Range [Note2]

Event 1c: A Non-active Primary CCPCH becomes better than an active Primary CCPCH [Note3]

Event 1d: Change of best cell [Note4, 5]

Event 1e: Other types of ranking of Primary CCPCHs (FFS)

Parameters	REFERENCE	TYPE	NOTE
Common parameter for all events		M	
Max number of reporting cells			
For each event		M	1a, 1b, 1c, 1d or 1e
Event ID		C	In event 1a,1b
Reporting Range		OC	In event 1a, 1b, 1c,1d
Hysteresis		C	In event 1a
Reporting deactivation threshold			Indicates the maximum number of cells allowed in the active set in order for event 1a to occur. Value 0 indicates "not applicable".

	Replacement activation threshold		C	In event 1c Indicates the minimum number of cells allowed in the active set in order for event 1c to occur. Value 0 indicates "not applicable".
	Time to trigger		M	Indicates the period of time between the timing of event detection and the timing of sending Measurement Report.
	Amount of reporting		M	Measurement for the indicated Transport CH ID is "released" after the indicated amount of reporting from the UE itself. FFS
	Reporting interval		M	Indicates the interval of periodical reporting when such reporting is triggered by an event triggered reports. A zero value indicates that event triggered periodical reporting shall not be applied. during the event is in the detected state FFS
	For RACH measurement reporting	Maximum number of reported cells on RACH	M	

[Note1: whether or not PCCPCH can be active is FFS]

[Note2: whether or not PCCPCH can be non-active is FFS]

[Note3: Details are FFS: It has been suggested to divide this event into two cases; I) a non-active PCCPCH exceeds the weakest active PCCPCH, II) a non-active PCCPCH exceeds the strongest active PCCPCH]

[Note4: When best PCCPCH in active set changes, all active cells are reported.]

[Note5: Whether this event can result in the reporting of non-active cells in addition to active cells is FFS.]

10.2.7.253 Inter-frequency measurement reporting criteria (FFS)

The triggering of the measurement report, e.g. periodical, event-triggered or immediate reporting for an inter-frequency measurement. Here is also specified if the measurement report should be transmitted using either acknowledged or unacknowledged data transfer on the DCCH.

Parameters	REFERENCE	TYPE	NOTE

10.2.7.264 Inter-system measurement reporting criteria (FFS)

The triggering of the measurement report, e.g. periodical, event-triggered or immediate reporting for an inter-system measurement. Here is also specified if the measurement report should be transmitted using either acknowledged or unacknowledged data transfer on the DCCH.

10.2.7.275 Traffic volume measurement reporting criteria

Contains the measurement reporting criteria information for a traffic volume measurement.

Parameters		REFERENCE	TYPE	NOTE
Common parameter for all transport CH				
For each transport CH	Transport CH ID		M	
	Threshold		M	
	Time to trigger		M	Indicates the period of time between the timing of event detection and the timing of sending Measurement Report.
	Pending time after trigger		M	Indicates the period of time during which it is forbidden to send any new measurement reports with the same measurement ID even if the triggering condition is fulfilled again.
	Amount of reporting		M	Measurement for the indicated Transport CH ID is “released” after the indicated amount of reporting from the UE itself. FFS
	Reporting interval		M	Indicates the interval of periodical report during the event is in the detected state FFS

10.2.7.286 Quality measurement reporting criteria (FFS)

(Note: Only the section is made.)

[10.2.7.297 UE internal measurement reporting criteria](#)

The triggering of the event-triggered reporting for an UE internal measurement. All events concerning UE internal measurements are labelled 6x where x is a, b, c,....

[Event 6a: The UE Tx power becomes larger than an absolute threshold](#)

[Event 6b: The UE Tx power becomes less than an absolute threshold](#)

[Event 6c: The UE Tx power reaches its minimum value](#)

[Event 6d: The UE Tx power reaches its maximum value](#)

[Event 6e: The UE RSSI reaches the UE’s dynamic receiver range](#)

Parameters		REFERENCE	TYPE	NOTE
For each event	Event ID		M	6a, 6b, 6c, 6d or 6e
	Time-to-trigger		M	Indicates the period of time between the timing of event detection and the timing of sending Measurement Report.
	Tx power threshold		C	In event 6a, 6b

10.2.7.3027 Periodical reporting criteria

Contains the periodical reporting criteria information. It is necessary only in the periodical reporting mode.

Parameters		REFERENCE	TYPE	NOTE
	Max number of reporting cells		O	Indicates the maximum number of cells to report.
	Amount of reporting		O	Measurement is "released" after the indicated amount of reporting from the UE itself
	Reporting interval		O	Indicates the interval of periodical report.

10.2.7.3128 Intra-frequency measurement event results

This IE contains the measurement event results that are reported to UTRAN for intra-frequency measurements.

Parameters		REFERENCE	TYPE	NOTE
	Event ID		M	
	Primary CCPCH info		M	

10.2.7.3229 Inter-frequency measurement event results (FFS)

This IE contains the measurement event results that are reported to UTRAN for inter-frequency measurements. The further division of this IE into parameters is FFS.

10.2.7.330 Inter-system measurement event results (FFS)

This IE contains the measurement event results that are reported to UTRAN for inter-system measurements. The further division of this IE into parameters is FFS.

10.2.7.344 Traffic volume measurement event results

Contains the event result for a traffic volume measurement.

Parameters		REFERENCE	TYPE	NOTE
	Transport CH ID		M	

10.2.7.352 Quality measurement event results (FFS)

(Note: Only the section is made.)

10.2.7.363 Measured results

Contains the measured results of the quantity indicated optionally by Reporting Quantity in Measurement Control. "Measured results" can be used for both event trigger mode and periodical reporting mode.

Parameters	REFERENCE	TYPE	NOTE
RAB ID + RLC buffers payload		O	
PCCPCH Info + Primary CCPCH RX E_c/I_0		O	
PCCPCH Info + Primary CCPCH RX SIR (RSCP/ISCP)		O	FFS
PCCPCH Info + Primary CCPCH RX power (RSCP)		O	FFS
PCCPCH Info + Path loss		O	FFS
PCCPCH Info + Path loss plus UL load		O	FFS
PCCPCH Info + Measured time difference to cell		O	
DL Transport CH BLER		O	
DL Transport CH BER		O	FFS
UE Transmission Power		O	
UE Position		O	
Cell ID		O	FFS

[10.2.7.37 SFN Measurement Indicator](#)

[Indicates whether the UE should read cell SFN of the target neighbour cell or not.](#)

10.2.8 Other Information elements

10.2.8.1 BCCH modification info

Indicates modification of the System Information on BCCH.

Parameters	REFERENCE	TYPE	NOTE
BCCH modification type		M	FFS
Modification time		O	FFS

10.2.8.2 Inter-system message

This Information Element contains one or several messages that are structured and coded according to the specification used for the system type indicated by the first parameter.

Parameters	REFERENCE	TYPE	NOTE
System type		M	E.g. GSM
Message(s)		M	Formatted and coded according to specification for the indicated system type.

11 Message and Information element abstract syntax (with ASN.1)

This chapter contains definitions for RRC PDUs and IEs using a subset of ASN.1 as specified in I2.01. PDU and IE definitions are grouped into separate ASN.1 modules.

Note that the proposal is to keep both chapter 10 and 11 (at least until all messages and information elements are fully discussed and agreed by 3GPP RAN WG2). Chapter 10 is intended to give an abstract description (in English) of the messages and information elements whereas chapter 11 should contain the exact normative definitions with all necessary details.

12 Message transfer syntax

Transfer syntax for RRC PDUs is derived from their abstract syntax definitions by use of encoding rules.

13 Protocol states

Service state diagram(s) of the RRC sublayer. (E.g. like in GSM0407.)

14 Protocol timers, counters and other parameters

Description of timers and counters and possible other parameters related to RRC procedures.

15 Specific functions (if applicable)

15.1 Intra-frequency measurements

15.1.1 Intra-frequency measurement quantities

1. Downlink E_c/I_0 (chip energy per total received channel power density)
2. Downlink path loss. (FFS)
3. Downlink received signal code power (RSCP) after despreading. (FFS)
4. Downlink signal-to-interference ratio (SIR) after despreading on a specific DL physical channel (RSCP/ISCP).(FFS)

15.1.2 Intra-frequency reporting events

Within the measurement reporting criteria field in the Measurement Control messages, the UTRAN notifies the UE which events that should trigger a measurement report. Examples of intra-frequency reporting events that would be useful for intra-frequency handover evaluation are given below. Note that normally the UEs do not need to report all these events. The listed events are the toolbox from which here the UTRAN can choose the reporting events that are needed for the implemented handover evaluation function, or other radio network functions.

All the illustrated events are measured with respect to any of the measurement quantities given in section 15.1.1. The measurement objects are the monitored primary common control physical channels (P-CCPCH). The reporting events are marked with vertical arrows in the figures below.

[Note: The events below are numbered 1A, 1B, 1C,... since all intra-frequency reporting events would be labeled 1X, inter-frequency reporting events would be labeled 2X, and so on for the other measurement types.]

15.1.2.1 Reporting event 1A: A Primary CCPCH enters the reporting range

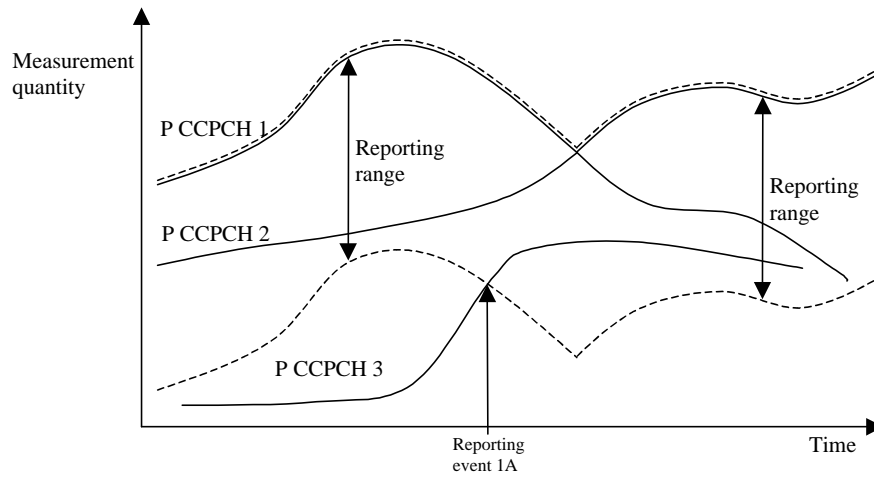

Figure 1: Figure 3634 Event-triggered report when a primary CCPCH enters the reporting range.

When event 1A is ordered by UTRAN in a measurement control message, the UE shall send a measurement report when a primary CCPCHs enters the reporting range. The reporting range is defined relative to the best primary CCPCH and is given in the measurement reporting criteria field in the MEASUREMENT CONTROL message.

The addition window of cells in event 1A is configured with the **reporting range** parameter common to many reporting events and an optional **hysteresis** parameter, which can be used to distinguish the addition window from reporting windows related to other measurement events.

The occurrence of event 1A is conditional on a **report deactivation threshold** parameter. This parameter indicates the maximum number of cells allowed in the active set for measurement reports to be triggered by event 1A to be transmitted.

Event 1A may be enhanced with an addition timer, which is configured with the **time-to-trigger** parameter (see section 15.1.4.2x.x.x.x). If a time-to-trigger value is used, a cell must continuously stay within the reporting range for the given time period, before the UE shall send a measurement report.

[Note: It is FFS, whether the cells triggering event 1A may be in the active set.]

15.1.2.2 Reporting event 1B: A primary CCPCH leaves the reporting range

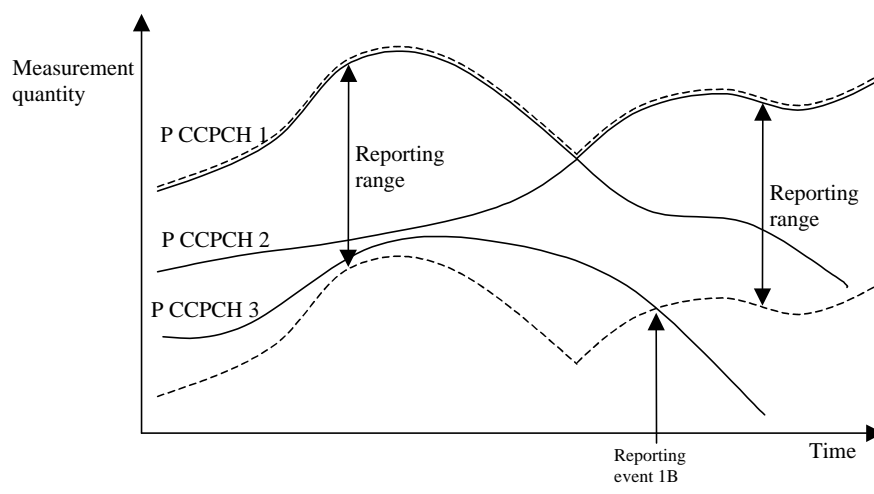

Figure 2: Figure 3735 Event-triggered report when a primary CCPCH leaves the reporting range.

When this event is ordered by UTRAN in a measurement control message, the UE shall send a measurement report when a primary CCPCHs leaves the reporting range. The reporting range is defined relative to the best primary CCPCH and is given in the measurement reporting criteria field in the MEASUREMENT CONTROL message.

The drop window of cells in event 1B is configured with the **reporting range** parameter common to many reporting events and an optional **hysteresis** parameter, which can be used to distinguish the drop window from reporting windows related to other measurement events.

Event 1B may be enhanced with a drop timer, which is configured with the **time-to-trigger** parameter. If the timer is used, the weakening cell must continuously stay below the reporting range for the given time period, before the UE may send a measurement report.

[Note: It is FFS whether cells triggering event 1B may belong to the monitored set cells, which are currently not in the active set]

15.1.2.3 Reporting event 1C: A non-active primary CCPCH becomes better than an active primary CCPCH

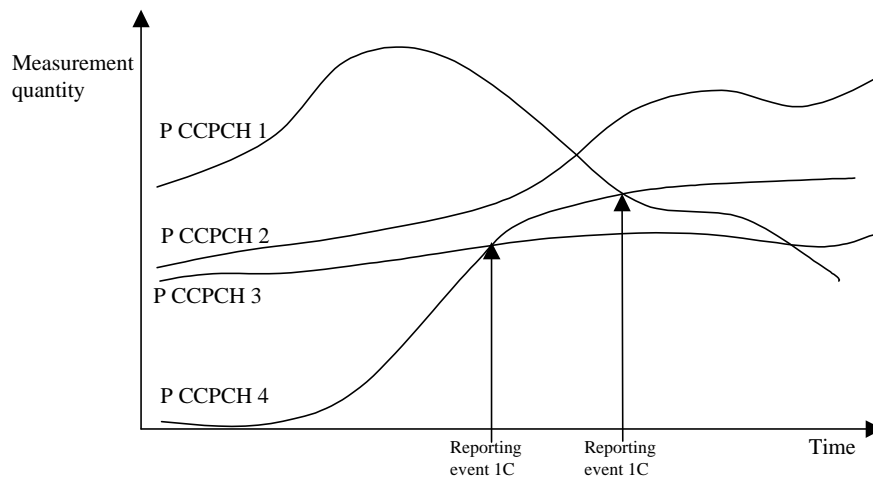

Figure 3: Figure 3836 A primary CCPCH that is not included in the active set becomes better than a primary CCPCH that is in the active set.

In this example the cells belonging to P-CCPCH 1, 2 and 3 are supposed to be in the active set, but the cell transmitting P-CCPCH 4 is not (yet) in the active set.

If a primary CCPCH that is not included in the active set becomes better than a primary CCPCH that is in the active set, and event 1C has been ordered by UTRAN, this event shall trigger a report to be sent from the UE.

This event may be used for replacing cells in the active set. It is activated if the number of active cells is equal to or greater than a **replacement activation threshold** parameter that UTRAN signals to the UE in the MEASUREMENT CONTROL message. This parameter indicates the minimum number of cells required in the active set for measurement reports triggered by event 1C to be transmitted.

15.1.2.4 Reporting event 1D: Change of best cell

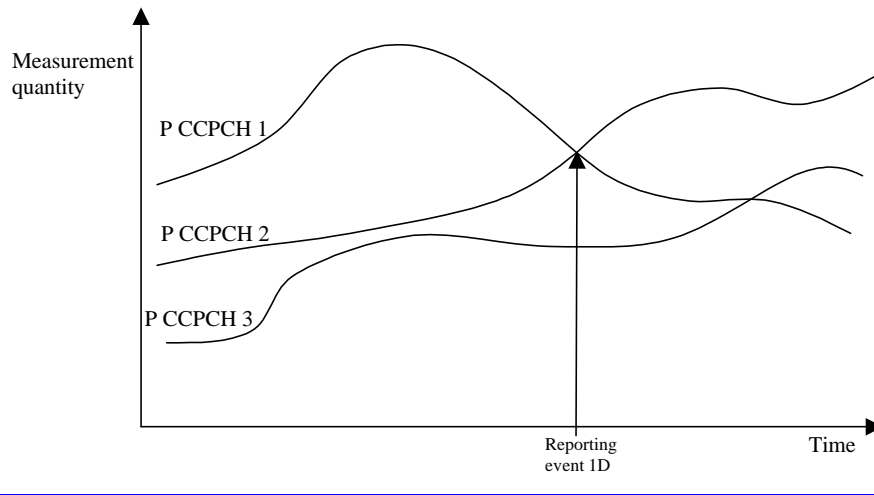

Figure 3- Figure 3937 A primary CCPCH becomes better than the previously best primary CCPCH.

If any of the primary CCPCHs within the reporting range becomes better than the previously best primary CCPCH, and event 1D has been ordered by UTRAN then, this event shall trigger a report to be sent from the UE. The corresponding report contains (at least) the new best primary CCPCH.

15.1.2.5 Reporting event 1E: A Primary CCPCH becomes better than an absolute threshold

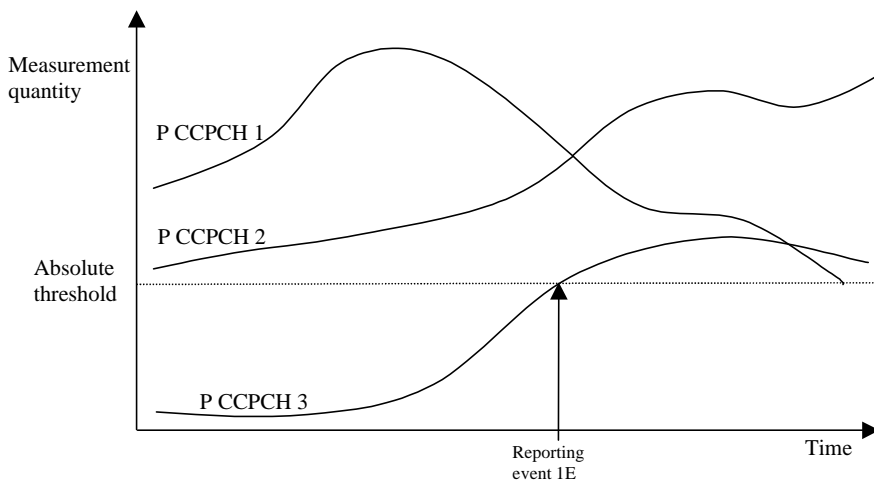

Figure 4038 Event-triggered report when a Primary CCPCH becomes better than an absolute threshold.

When this event is ordered by UTRAN in a measurement control message the UE shall send a report when the Measurement quantity of a Primary CCPCH becomes better than an absolute threshold. The corresponding report contains (at least) the involved Primary CCPCH.

15.1.2.6 Reporting event 1F: A Primary CCPCH becomes worse than an absolute threshold

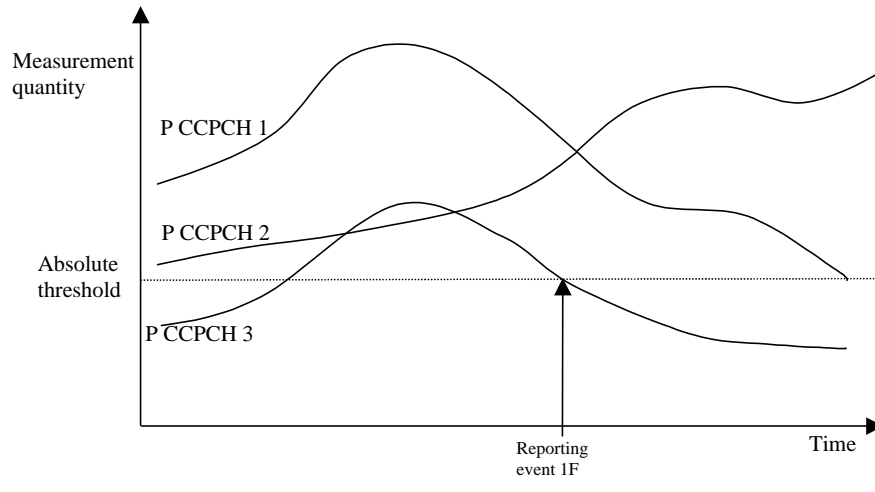

Figure 4139 Event-triggered report when a Primary CCPCH becomes worse than an absolute threshold.

When this event is ordered by the UTRAN in a measurement control message the UE shall send a report when a primary CCPCH becomes worse than an absolute threshold. The corresponding report contains (at least) the involved Primary CCPCH.

15.1.3 Event-triggered periodic intra-frequency measurement reports

15.1.3.1 Cell addition failure

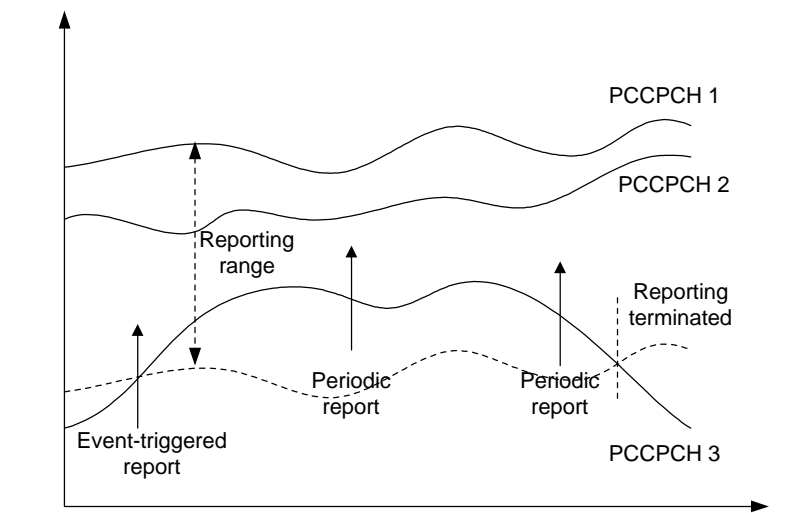

Figure 4240 Periodic reporting triggered by event 1A

When a cell enters the reporting range and triggers event 1A, the UE shall transmit a MEASUREMENT REPORT to the UTRAN and typically this may result in an update of the active set. However, in some situations the UTRAN may be unable to add a strong cell to the active set typically due to capacity shortage for example.

The UE shall continue reporting after the initial report by reverting to periodical measurement reporting if the reported cell is not added to the active set. This is illustrated in Figure 42Figure 40. During periodic reporting the UE shall

transmit MEASUREMENT REPORT messages to the UTRAN at predefined intervals. The reports shall include reporting information of the cells in the current active set and of the monitored cell(s) in the reporting range.

Event-triggered periodic measurement reporting shall be terminated either when there are no longer any monitored cell(s) within the reporting range or when the UTRAN has added cells to the active set so that it includes the maximum number of cells (defined by the **reporting deactivation threshold** parameter), which are allowed for event 1A to be triggered.

The reporting period is assigned by the UTRAN. If the reporting period is set to zero event-triggered measurement reporting shall not be applied.

15.1.3.2 Cell replacement failure

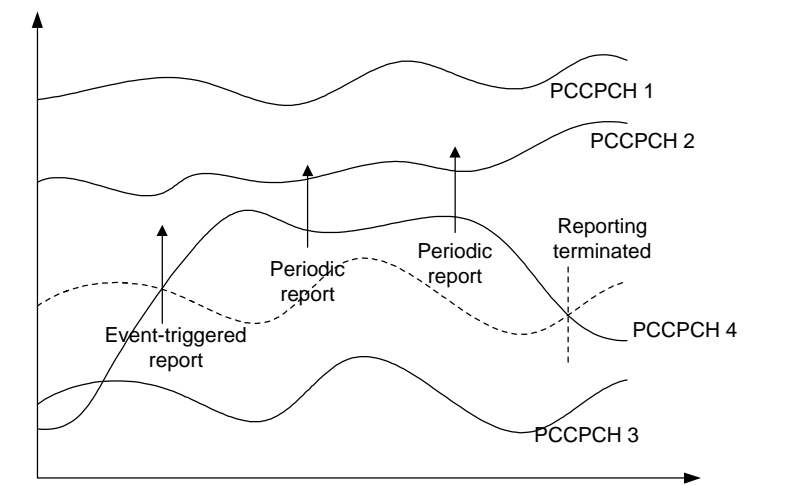

Figure 434 Periodic reporting triggered by event 1C

When a cell enters the replacement range and triggers event 1C, the UE shall transmit a MEASUREMENT REPORT to the UTRAN and typically this may result in the replacement of the weakest active cell. If the UTRAN is unable to replace the cell due to for example capacity shortage, it is beneficial to receive continuous reports in this case as well.

The UE shall revert to periodical measurement reporting if the UTRAN does not update the active set after the transmission of the measurement report. This is illustrated in ~~Figure 43~~Figure 44. During periodic reporting the UE shall transmit MEASUREMENT REPORT messages to the UTRAN at predefined intervals. The reports shall include reporting information of the cells in the current active set and of the monitored cell(s) in the replacement range.

Event-triggered periodic measurement reporting shall be terminated either when there are no longer any monitored cell(s) within the replacement range or when the UTRAN has removed cells from the active set so that there are no longer the minimum amount of active cells for event 1C to be triggered (as defined by the **replacement activation threshold** parameter).

The reporting period is assigned by the UTRAN. If the reporting period is set to zero, event-triggered measurement reporting shall not be applied.

15.1.43 Intra-frequency reporting mechanisms available for modifying intra-frequency measurement reporting behaviour

15.1.43.1 Hysteresis

To limit the amount of event-triggered reports, a hysteresis parameter may be connected with each reporting event given above. The value of the hysteresis is given to the UE in the Reporting criteria field of the Measurement Control message.

In the example in [figure 7](#) [Figure 44](#) [Figure 42](#), the hysteresis ensures results in that the event ID (that primary CCPCH 2 becomes the best cell) is not reported until the difference is equal to the hysteresis value. The fact that primary CCPCH 1 becomes best afterwards is not reported at all in the example since the primary CCPCH 1 does not become sufficiently much better than the primary CCPCH 2.

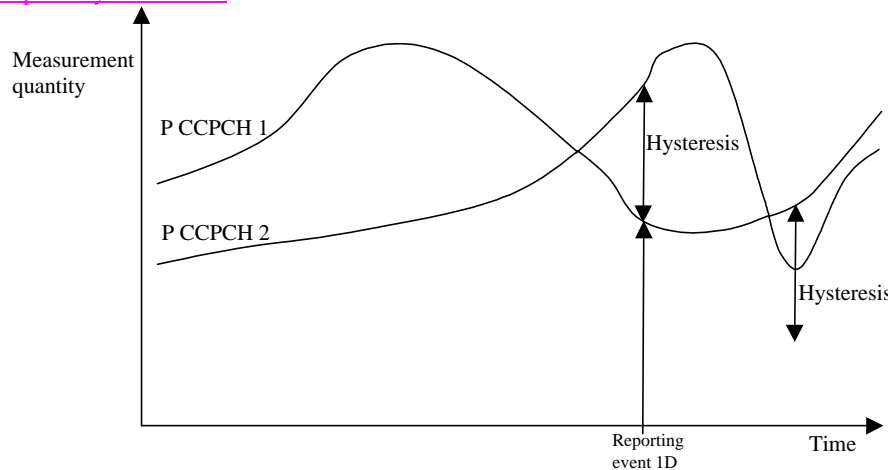

[Figure 7:Figure 4442](#) Hysteresis limits the amount of measurement reports.

15.1.43.2 Time-to-trigger

To limit the measurement signalling load, a time-to-trigger parameter could be connected with each reporting event given above. The value of the time-to-trigger is given to the UE in the Reporting criteria field of the Measurement Control message.

The effect of the time-to-trigger is that the report is triggered only after that the conditions for the event have existed for the specified time-to-trigger. In the example in [figure 8](#) [Figure 46](#) [Figure 43](#), the use of time-to-trigger means causes that the event that (primary CCPCH 3 enters the reporting range) is not reported until it has been within the range for the time given by the time-to-trigger parameter.

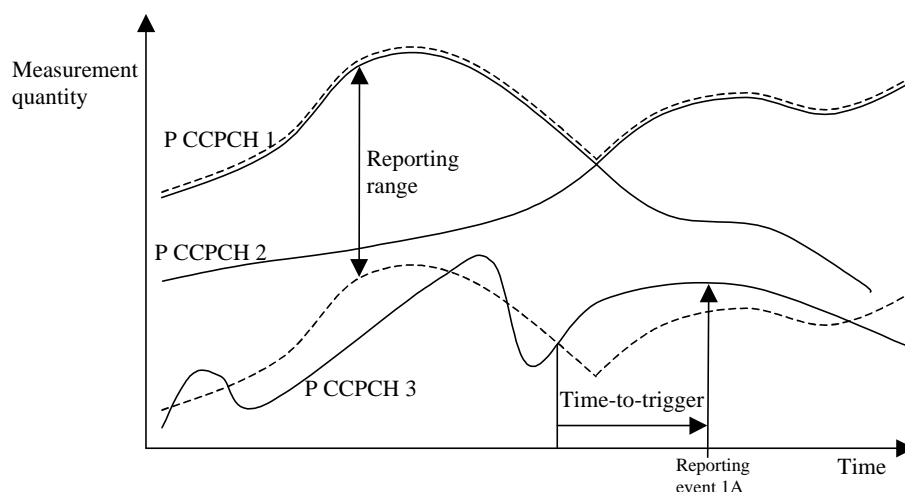

[Figure 8:Figure 4643](#) Time-to-trigger limits the amount of measurement reports.

Note that the time-to-trigger could be combined with hysteresis, i.e. a hysteresis value is added to the measurement quantity before evaluating if the time-to-trigger timer should be started.

15.1.4.3 Cell individual offsets

For each cell that is monitored, an offset can be assigned with inband signalling. The offset can be either positive or negative. The offset is added to the measurement quantity before the UE evaluates if an event has occurred. The UE receives the cell individual offsets for each primary CCPCH in the measurement object field of the MEASUREMENT CONTROL message.

For example, in [figure 9](#) [Figure 48](#) [Figure 44](#), since an offset is added to primary CCPCH 3, it is the dotted curve that is used to evaluate if an event occurs. Hence, [this means it results in](#) that measurement reports from UE to UTRAN are triggered when primary CCPCH plus the corresponding offset, i.e. the dotted curve, leaves and enters the reporting range and when it gets better than primary CCPCH 1 (if these events have been ordered by UTRAN). This offset mechanism provides the network with an efficient tool to change the reporting of an individual primary CCPCH.

By applying a positive offset, as in [Figure 48](#) [Figure 44](#) [figure 9](#), the UE will send measurement reports as if the primary CCPCH is offset x dB better than what it really is. This could be useful if the operator knows that a specific cell is interesting to monitor more carefully, even though it is not so good for the moment. In the example in [figure 9](#) [Figure 48](#) [Figure 44](#), the operator might know by experience that in this area primary CCPCH 3 can become good very quickly (e.g. due to street corners) and therefore [that it is worth reporting](#) more intensively. Depending on the implemented handover evaluation algorithm, this may result in [that the cell with primary CCPCH 3 being](#) included in the active set earlier than would have been the case without the positive offset.

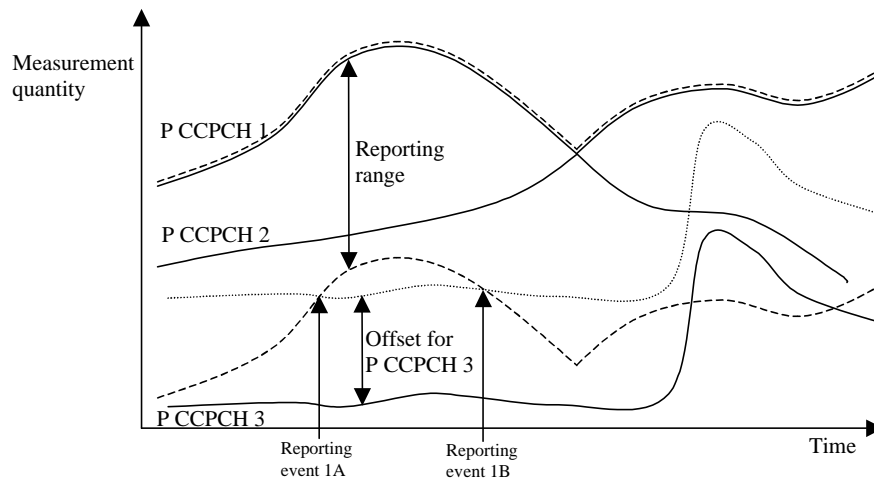

Figure 9: Figure 4844 A positive offset is applied to primary CCPCH 3 before event evaluation in the UE.

Correspondingly, the operator can choose to apply a negative offset to a primary CCPCH. Then the reporting on that primary CCPCH is limited, and the corresponding cell may be, at least temporarily, excluded from the active set.

The cell individual offset can be seen as a tool to move the cell border. It is important to note that the offset is added before triggering events, i.e. [the offset is added by](#) the UE before evaluating if a measurement report should be sent, as opposed to offsets that are applied in the network and used for the actual handover evaluation.

15.1.4.4 Forbid a Primary CCPCH to affect the reporting range

The reporting range affects the reporting events 1A and 1B presented above. The reporting range is defined relative to the best Primary CCPCH. However, there could be cases where it is good to forbid a specific Primary CCPCH to affect the reporting range. For example in [Figure 50](#) [Figure 45](#) the network has requested the UE to not let Primary CCPCH 3 affect the reporting range. This mechanism could be effective if the operator knows by experience that the quality of Primary CCPCH 3 is very unstable in a specific area and therefore should not affect the reporting of the other Primary CCPCHs.

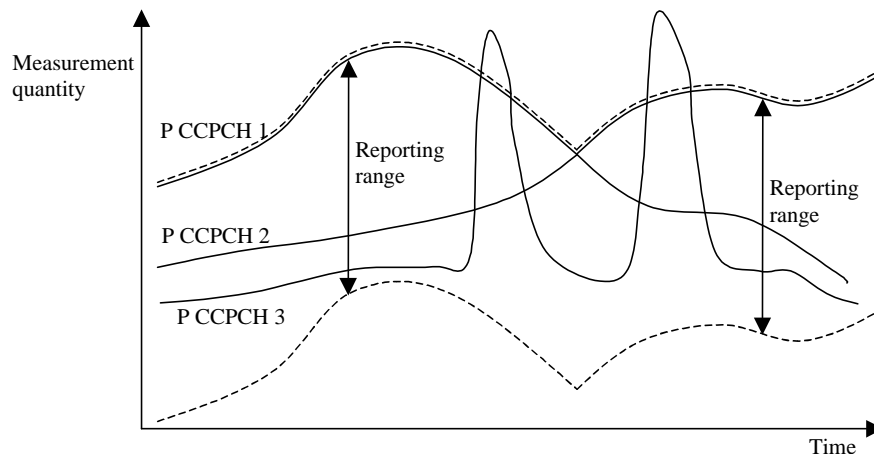

Figure 5045 Primary CCPCCH 3 is forbidden to affect the reporting range.

15.1.54 Report quantities

In the event-triggered measurement reports, mandatory information connected to the events is always reported. For instance, at the event “a primary CCPCCH enters the reporting range” the corresponding report identifies the primary CCPCCH that entered the range.

However, besides this mandatory information, UTRAN should be able to optionally require additional measurement information in the report to support the radio network functions in UTRAN. Furthermore, it will allow the UTRAN to use the UE as a general tool for radio network optimisation, if necessary.

Examples of report quantities that may be appended to the measurement reports are:

[Note: This list is general and does also apply for reports of other measurement types than the intra-frequency type. The list is not final.]

- Downlink transport channel block error rate
- Downlink transport channel bit error rate
- Downlink E_c/I_0 on primary CCPCCH (e.g. used for initial DL power setting on new radio links.)
- “Time difference between the received primary CCPCCH frame-timing from the target cell and the earliest received existing DPCH path”. [Note: This measurement is identified in 25.211 [2] (denoted T_m in chapter 7)]
- UE transmit power
- UE position (FFS)
- Downlink SIR (RSCP/ISCP) on the traffic channels after RAKE combining (FFS)
- Downlink SIR (RSCP/ISCP) on primary CCPCCH (e.g. used for initial DL power setting on new radio links.)(FFS)

15.2 Traffic Volume Measurements

15.2.1 Traffic Volume Measurement Quantity

For traffic volume measurements in the UE only one quantity is measured. This quantity is RLC buffer payload in number of bytes. In order to support a large variation of bit rates and RLC buffer size capabilities, a non-linear scale should be used [Note: Details are FFS]. Since, the expected traffic includes both new and retransmitted RLC payload units all these should be included in the payload measure. It should also be noted that traffic volume measurements are only applicable for acknowledged and unacknowledged mode.

According to what is stated in the Measurement Control message, the UE should support measuring of buffer payload for a specific RAB, RABs multiplexed onto the same Transport channel and the total UE buffer payload (the same as one transport channel for a UE that uses RACH).

15.2.2 Traffic Volume reporting events

Traffic volume can be reported in two different ways, periodical and event triggered. For periodical reporting the UE simply measures the number of bytes for the transport channel (i.e. the RLC buffers of the RABs multiplexed onto that transport channel) stated in the measurement control message and reports the traffic volume at the given time instants. For event triggered reporting is performed when, exceeding a threshold is exceeded triggers the report. The what reporting quantities which that should be included in the report is stated in the measurement control message. This could for example e.g. be which RABs or RLC buffers to include when sending the payload to the network.

15.2.2.1 Reporting event 4 A: RLC buffer payload exceeds an absolute threshold

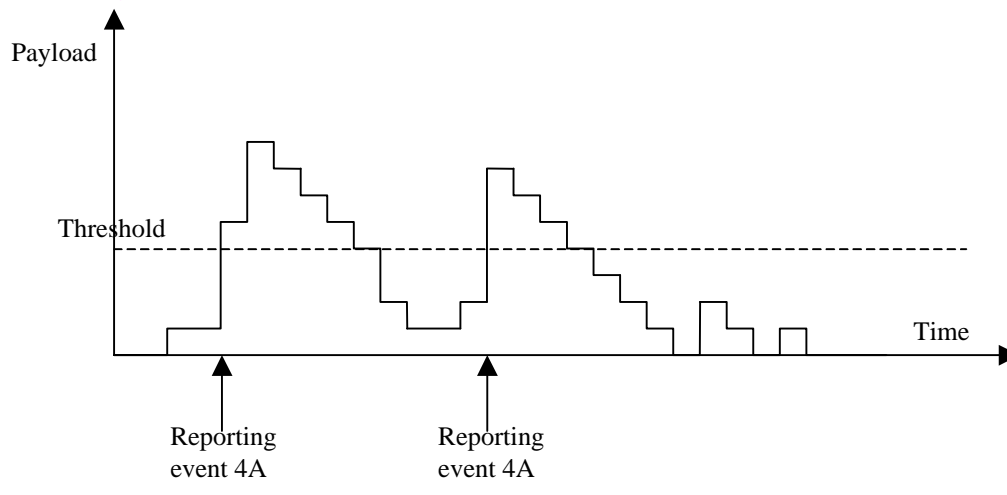

Figure 1: Figure 5246 Event triggered report when RLC buffer payload exceeds a certain threshold.

If the monitored payload exceeds an absolute threshold, this is an event that could trigger a report. The corresponding report contains at least which transport channel that triggered the report.

15.2.3 Traffic volume reporting mechanisms

Traffic volume measurement triggering could be associated with both a *time-to-trigger* and a *pending time after trigger*. The time-to-trigger is used to get time domain hysteresis, i.e. the condition must be fulfilled during the time-to-trigger time before a report is sent. Pending time after trigger is used to limit consecutive reports when one traffic volume measurement report already has been sent. This is described in detail below.

15.2.3.1 Pending time after trigger

This timer is started in the UE when a measurement report has been triggered. The UE is then during this time period forbidden to send any new measurement reports with the same measurement ID during this time period even when although the triggering condition is fulfilled again. Instead the UE waits until the timer has suspended. If the payload still is still above the threshold when the timer has expired been suspended, the UE sends a new measurement report. Otherwise it waits for a new triggering.

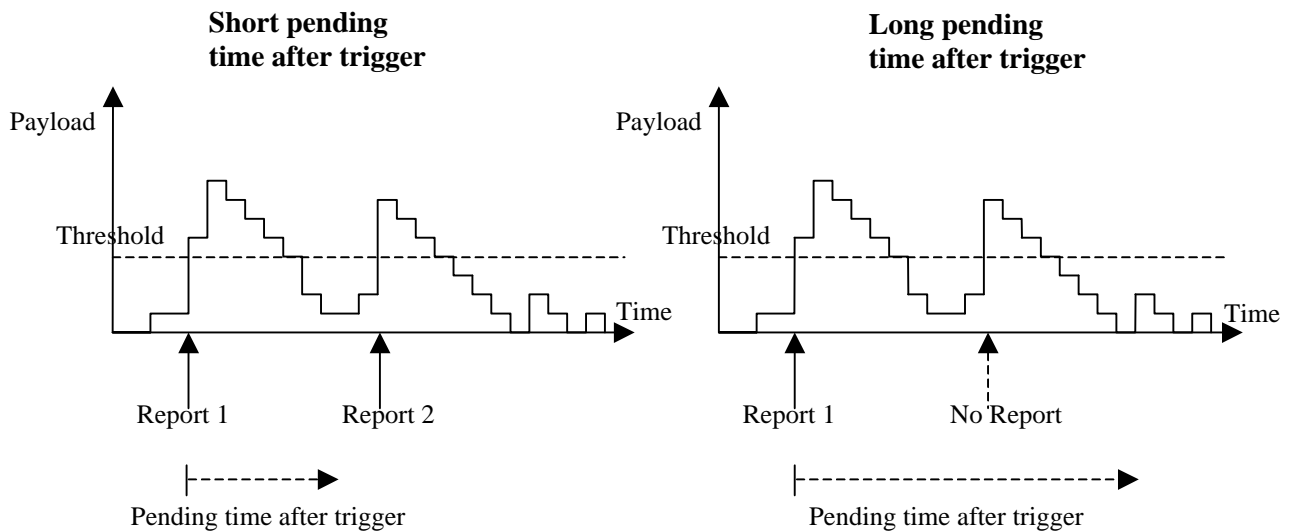

Figure 2- Figure 5347 Pending time after trigger limits the amount of consecutive measurement reports.

In Figure 2- Figure 5347 it is shown that by increasing the pending time after trigger a triggered second event does not result in a measurement report.

15.3 UE internal measurements

15.3.1 UE internal measurement quantities

For UE internal measurements the following measurement quantities exist:

1. [UE transmission \(Tx\) power](#)
2. [UE received signal strength power \(RSSI\)](#)

15.3.2 UE internal measurement reporting events

In the Measurement reporting criteria field in the Measurement Control messages, the UTRAN notifies the UE of which events should trigger a measurement report. UE internal measurement reporting events that can trigger a report are given below. The reporting events are marked with vertical arrows in the figures below. All events can be combined with time-to-trigger. In that case, the measurement report is only sent if the condition for the event has been fulfilled for the time given by the time-to-trigger parameter

[Note: The reporting events are numbered 6A, 6B, 6C... where 6 denotes that the event belongs to the type UE internal measurements.]

15.3.2.1 Reporting event 6A: The UE Tx power becomes larger than an absolute threshold

When this event is ordered by UTRAN in a measurement control message, the UE shall send a measurement report when the UE transmission power becomes larger than a predefined threshold. The corresponding report identifies the threshold that was exceeded.

15.3.2.2 Reporting event 6B: The UE Tx power becomes less than an absolute threshold

When this event is ordered by UTRAN in a measurement control message, the UE shall send a measurement report when the UE transmission power becomes less than a predefined threshold. The corresponding report identifies the threshold that the UE Tx power went below.

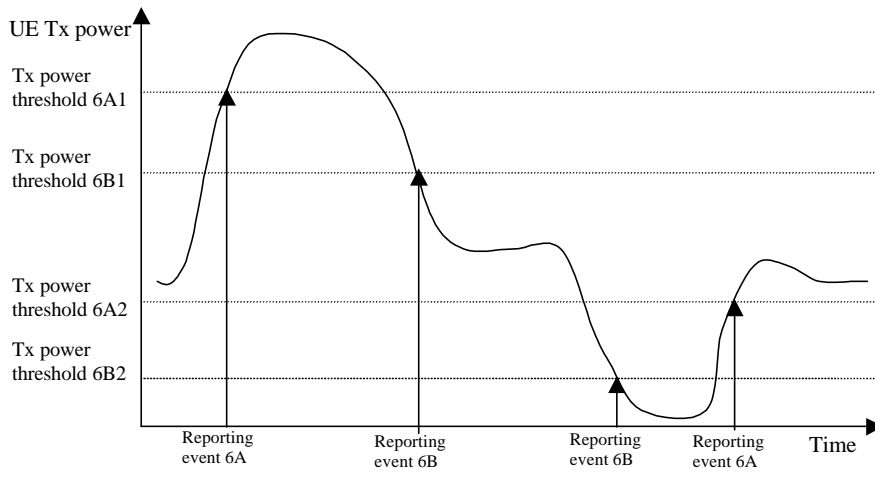

Figure 5448 Event-triggered measurement reports when the UE Tx power becomes larger or less than absolute thresholds.

15.3.2.3 Reporting event 6C: The UE Tx power reaches its minimum value

When this event is ordered by UTRAN in a measurement control message, the UE shall send a measurement report when the UE Tx power reaches its minimum value.

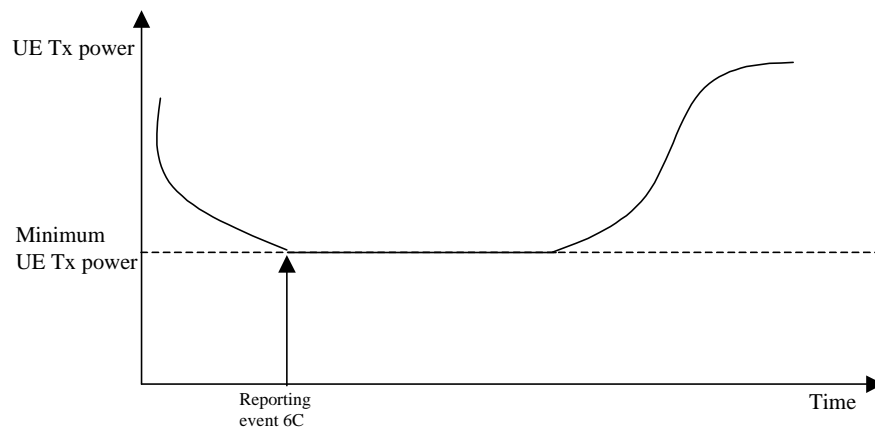

Figure 5549 Event-triggered measurement report when the UE Tx power reaches its minimum value.

15.3.2.4 Reporting event 6D: The UE Tx power reaches its maximum value

When this event is ordered by UTRAN in a measurement control message, the UE shall send a measurement report when the UE Tx power reaches its maximum value.

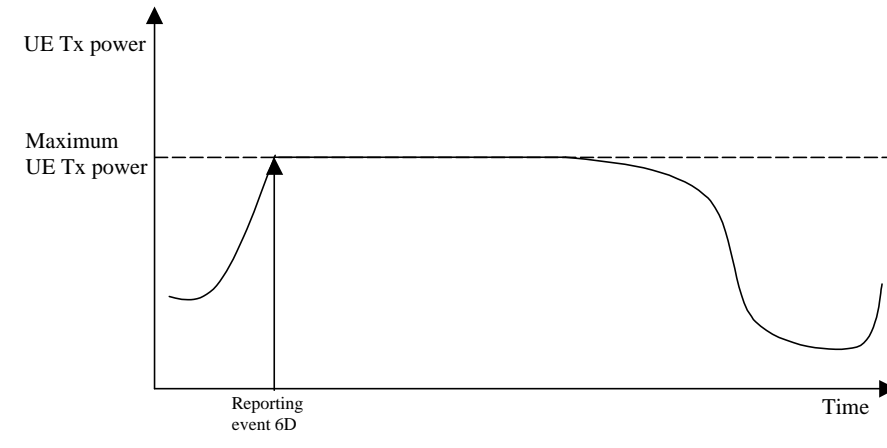

Figure 5650 Event-triggered report when the UE Tx power reaches its maximum value.

15.3.2.5 Reporting event 6E: The UE RSSI reaches the UE's dynamic receiver range

When this event is ordered by UTRAN in a measurement control message, the UE shall send a measurement report when the UE RSSI reaches the UE's dynamic receiver range.

15.43 Dynamic Resource Allocation Control of Uplink DCH

The network uses this procedure to dynamically control the allocation of resources on an uplink DCH, this is achieved by sending transmission probability and maximum data rate information elements.

This procedure is initiated with a SYSTEM INFORMATION message from the NW RRC and applies to all UEs having uplink DCH's that are dynamically controlled by this procedure. Such uplink DCH's could be established through RAB establishment procedure, RAB reconfiguration procedure, RAB release procedure or Transport Channel Reconfiguration procedure by using a 'Dynamic Control' parameter to indicate that the DCH is controlled by the DRAC procedure.

This function is launched by UE upon reception of a SYSTEM INFORMATION message comprising DRAC parameters (ptr, Max. bit rate).

1. The UE randomly selects $p \in [0,1]$.
2. The UE then checks its permission: if $p < p_{tr}$ the permission is granted for $T_{validity}$ frames, otherwise the UE waits for T_{retry} frames before re-attempting access.
3. A new subset of TFCS is sent to MAC, according to the permission result and to maximum bit rate granted. This subset of TFCS shall only affect DCH that are controlled by this procedure.

Transmission time validity, Time duration before retry and Silent period duration before release are indicated to the UE together with the "Dynamic Control" parameter (i.e. at the establishment of a DCH controlled by this procedure) and may eventually be changed through RAB reconfiguration.

When the UE is in soft handover, the UE may have to listen to the CCCH system information of 1 or several cells in the Active Set in order to react to the most stringent parameters, e.g. the lowest product $ptr * \text{max bit rate}$. In case of conflict in the reception of multiple FACH, the UE shall listen to the FACH with a priority order corresponding to the rank of cells in its Active Set (i.e. the FACH of the best received cells should be listened to first).

Whether the support for DRAC function is dependent on the UE capability or UE service capability is FFS

16 Handling of unknown, unforeseen and erroneous protocol data

This section specifies procedures for the handling of unknown, unforeseen, and erroneous protocol data by the receiving entity. These procedures are called "error handling procedures".

17 SDL

This section describes the functionality of the protocol in descriptive SDL.

18 Appendices: Examples of operation

19 History

Document history		
Date	Version	Comment
January 1999	0.0.1	<p>Created following the first 3GPP WG2 meeting . Text from two documents were merged. These documents were:</p> <p>ETSI SMG2 UMTS L23 EG document: 'Description of the RRC protocol, YY.31, v0.2.0, ETSI L23EG Tdoc 065/99, January 19, 1999.</p> <p>and</p> <p>TTC/ARIB document: 'Draft UE-UTRAN L3 RRC signalling protocol', Vol. 9, Ver 1.0.0, January 14, 1999, ETSI L23 EG Tdoc 010/99</p> <p>The ETSI document was taken as the baseline document and change marks are given in v 0.0.1 of S2.31 with respect to the ETSI document.</p>
March 1999	0.0.2	Updated according to 3GPP template. There were no changes to S2.31 agreed at the January 1999 meeting
April 1999	0.1.0	Updated to include new message and information element functional descriptions as described in TSGR2#3(99)220 (report of RRC email ad-hoc). New chapter headings 10-17 have been added and Annex 1 removed. Text updated to reflect new definitions for paging messages.
April 1999	TS 25.331 V1.0.0	Noted by TSG-RAN as TS 25.331V1.0.0
May 1999	V1.0.1	Tables in Section 10 edited so that they read correctly when opened from WORD 6.0
June 1999	V1.1.0	Edited following May 1999 RAN2meeting. Includes modifications to RRC procedures agreed in RRC procedures email ad-hoc (and mostly captured in Tdoc 376). Note that new procedures on RNTI re-allocation and RRC status added. Also includes a large number of modifications to RRC parameters and information elements most of which were captured in Tdoc 380. Updated to WORD 97.
July 1999	V1.2.0	Edited following the RAN2 meeting held in July 1999. Includes changes agreed in an email discussion, these changes were in the main captured in Tdoc 525. Also includes changes agreed at the RRC ad-hoc which was held during the meeting (See Tdoc 680). A number of other changes were also agreed - see meeting minutes.

Rapporteur for TS 25.331 is:

Stephen Barrett
Motorola, GSM Products Division, UK

Tel: +44 1793 566217

Fax: +44 1793 566225

Email: sbarret1@ecid.cig.mot.com

This document is written using Microsoft Word 97.