

TSG-RAN Working Group 2 (Radio layer 2 and Radio layer 3)  
Sophia Antipolis, France, August 16<sup>th</sup> to 20<sup>th</sup> 1999

**TSGR2#6(99)70**

**Agenda Item:** 4.2

**Source:** Editor

**Title:** S25.302 v3.0.0 Services provided by the Physical

**Document for:** Approval

This is the version incorporating the changes approved at the last RANWG2#5. It was circulated on the RAN reflector for 30 days till Aug 13th for approval by correspondence, as decided at the fourth TSG-RAN meeting in Miami. As there were no comments received, it should now be approved as v3.0.0.

# TS 25.302 V23.40.0 (1999-078)

*Technical Specification*

**3<sup>rd</sup> Generation Partnership Project (3GPP);  
Technical Specification Group (TSG) RAN;  
Working Group 2 (WG2);**

## **Services provided by the Physical Layer**



The present document has been developed within the 3<sup>rd</sup> Generation Partnership Project (3GPP™) and may be further elaborated for the purposes of 3GPP.

The present document has not been subject to any approval process by the 3GPP Organisational Partners and shall not be implemented.

This Specification is provided for future development work within 3GPP only. The Organisational Partners accept no liability for any use of this Specification.

Specifications and reports for implementation of the 3GPP™ system should be obtained via the 3GPP Organisational Partners' Publications Offices.

Reference

---

<Workitem> (<Shortfilename>.PDF)

Keywords

---

Digital cellular telecommunications system,  
Universal Mobile Telecommunication System  
(UMTS), UTRA, IMT-2000

**3GPP**

Postal address

---

Office address

---

Internet

---

secretariat@3gpp.org  
Individual copies of this deliverable  
can be downloaded from  
<http://www.3gpp.org>

# Contents

1	Scope .....	5
2	References.....	5
3	Definitions and Abbreviations .....	6
3.1	Definitions .....	6
3.2	Abbreviations.....	6
4	Interfaces to the physical layer .....	8
4.1	Interface to MAC .....	8
4.2	Interface to RRC .....	8
5	Services and functions of the physical layer.....	8
5.1	General.....	8
5.2	Overview of L1 functions .....	9
5.3	L1 interactions with L2 retransmission functionality.....	9
6	Model of physical layer of the UE.....	9
6.1	Uplink models.....	9
6.2	Downlink models .....	11
6.3	Relay link Model.....	14
7	Formats and configurations for L1 data transfer.....	14
7.1	General concepts about Transport Channels .....	14
7.1.1	Transport Block.....	14
7.1.2	Transport Block Set.....	14
7.1.3	Transport Block Size .....	15
7.1.4	Transport Block Set Size .....	15
7.1.5	Transmission Time Interval.....	15
7.1.6	Transport Format .....	15
7.1.7	Transport Format Set.....	16
7.1.8	Transport Format Combination .....	16
7.1.9	Transport Format Combination Set .....	16
7.1.10	Transport Format Indicator (TFI).....	17
7.1.11	Transport Format Combination Indicator (TFCI).....	17
7.1.12	Rate matching.....	17
7.2	Types of Transport Channels .....	18
7.3	Slotted Mode .....	20
8	UE Simultaneous Physical Channels combinations .....	20
8.1	Uplink .....	20
8.2	Downlink .....	21
9	Measurements provided by the physical layer.....	22
9.1	Measurements of downlink channels .....	23
9.1.1	CFN-SFN Observed time difference .....	23
9.1.2	Observed time difference to GSM cell .....	23
9.1.3	Primary CCPCH RX $E_c/I_0$ .....	23
9.1.4	Primary CCPCH Rx SIR .....	<a href="#">2423</a>
9.1.5	Primary CCPCH Rx RSCP.....	<a href="#">2423</a>
9.1.6	Primary CCPCH Rx ISCP .....	<a href="#">2423</a>
9.1.7	DPCCH SIR .....	<a href="#">2423</a>
9.1.8	UTRA Cell Signal strength (RSSI) .....	<a href="#">2523</a>
9.1.9	Alternate mode Signal strength .....	<a href="#">2523</a>
9.1.10	Transport CH BLER.....	<a href="#">2523</a>
9.1.11	Physical CH BER .....	<a href="#">2523</a>
9.1.12	Total Tx Power.....	<a href="#">2623</a>
9.1.13	Code Tx Power.....	<a href="#">2623</a>
9.2	Measurements on uplink channels .....	<a href="#">2623</a>
9.2.1	UL load.....	<a href="#">2623</a>

9.2.2	UE Tx Power .....	<a href="#">2623</a>
9.2.3	Transport CH BLER.....	<a href="#">2723</a>
9.2.4	Physical CH BER .....	<a href="#">2723</a>
9.3	Miscellaneous measurements.....	<a href="#">2723</a>
9.3.1	Time of Arrival (TOA).....	<a href="#">2723</a>
9.3.2	SFN-SFN Observed time difference.....	<a href="#">2823</a>
9.3.3	Frequency Offset (FO) .....	<a href="#">2823</a>
10	Primitives of the physical layer .....	<a href="#">2923</a>
10.1	10.1 Generic names of primitives between layers 1 and 2.....	<a href="#">2923</a>
10.1.1	10.1.1 PHY-Data-REQ.....	<a href="#">2923</a>
10.1.2	PHY- Data-IND.....	<a href="#">3023</a>
10.1.3	10.1.3 PHY-Status-IND.....	<a href="#">3023</a>
10.2	Generic names of primitives between layers 1 and 3.....	<a href="#">3023</a>
10.2.1	STATUS PRIMITIVES .....	<a href="#">3023</a>
10.2.2	CONTROL PRIMITIVES.....	<a href="#">3123</a>
10.3	Parameter definition.....	<a href="#">3323</a>
10.3.1	Error code.....	<a href="#">3323</a>
10.3.2	Event value.....	<a href="#">3423</a>
10.3.3	Physical channel description .....	<a href="#">3423</a>
10.3.4	Transport channel description .....	<a href="#">3523</a>
11	Radio Frame transmission .....	<a href="#">3523</a>
11.1	Downlink Frame format.....	<a href="#">3523</a>
11.2	Uplink Frame format.....	<a href="#">3523</a>
11.3	Order of bit transmission.....	<a href="#">3523</a>
Annex A:	Description of Transport Formats .....	<a href="#">3623</a>
Annex B (Informative):	Example of Transport format attributes for AMR speech codec .....	<a href="#">3723</a>
12	History .....	<a href="#">3823</a>

---

# Intellectual Property Rights

IPRs essential or potentially essential to the present deliverable may have been declared to 3GPP. The information pertaining to these essential IPRs, if any, is publicly available for **3GPP members and non-members, free of charge**. This can be found in the latest version of the 3GPP Technical Report: ETR 314: "Intellectual Property Rights (IPRs); Essential or potentially Essential, IPRs notified to 3GPP in respect of 3GPP standards". The most recent update of ETR 314, is available on the 3GPP web server or on request from the Secretariat.

Pursuant to the 3GPP Interim IPR Policy, no investigation, including IPR searches, has been carried out by 3GPP. No guarantee can be given as to the existence of other IPRs not referenced in the ETR 314, which are, or may be, or may become, essential to the present document.

---

## Foreword

This Technical Specification has been produced by the 3GPP.

The contents of the present document are subject to continuing work within the TSG and may change following formal TSG approval. Should the TSG modify the contents of this TS, it will be re-released by the TSG with an identifying change of release date and an increase in version number as follows:

Version 3.y.z

where:

- x the first digit:
  - 1 presented to TSG for information;
  - 2 presented to TSG for approval;
  - 3 Indicates TSG approved document under change control.
- y the second digit is incremented for all changes of substance, i.e. technical enhancements, corrections, updates, etc.
- z the third digit is incremented when editorial only changes have been incorporated in the specification.

---

## 1 Scope

The present document is a technical specification of the services provided by the physical layer of UTRA to upper layers.

---

## 2 References

References may be made to:

- a) specific versions of publications (identified by date of publication, edition number, version number, etc.), in which case, subsequent revisions to the referenced document do not apply;
- b) all versions up to and including the identified version (identified by "up to and including" before the version identity);
- c) all versions subsequent to and including the identified version (identified by "onwards" following the version identity); or
- d) publications without mention of a specific version, in which case the latest version applies.

A non-specific reference to an ETS shall also be taken to refer to later versions published as an EN with the same number.

- [1] ETSI UMTS 23.10 : UMTS Access Stratum Services and Functions
- [2] 3GPP TS 25.301 : Radio Interface Protocol Architecture

- [3] 3GPP TS 25.212 : UTRA FDD multiplexing, channel coding and interleaving description
- [4] 3GPP TS 25.222 : UTRA TDD multiplexing, channel coding and interleaving description

## 3 Definitions and Abbreviations

### 3.1 Definitions

See [3] for a definition of fundamental concepts and vocabulary.

### 3.2 Abbreviations

ARQ	Automatic Repeat Request
BCCCH	Broadcast Control Channel
BCH	Broadcast Channel
C-	Control-
CC	Call Control
CCCH	Common Control Channel
CCH	Control Channel
CCTrCH	Coded Composite Transport Channel
CN	Core Network
CRC	Cyclic Redundancy Check
DC	Dedicated Control (SAP)
DCA	Dynamic Channel Allocation
DCCH	Dedicated Control Channel
DCH	Dedicated Channel
DL	Downlink
DRNC	Drift Radio Network Controller
DSCH	Downlink Shared Channel
DTCH	Dedicated Traffic Channel
FACH	Forward Link Access Channel
FAUSCH	Fast Uplink Signaling Channel
FCS	Fame Check Sequence
FDD	Frequency Division Duplex
GC	General Control (SAP)
HO	Handover
ITU	International Telecommunication Union
kbps	kilo-bits per second
L1	Layer 1 (physical layer)
L2	Layer 2 (data link layer)
L3	Layer 3 (network layer)
LAC	Link Access Control
LAI	Location Area Identity
MAC	Medium Access Control
MM	Mobility Management
Nt	Notification (SAP)
OCCH	ODMA Common Control Channel
ODCCH	ODMA Dedicated Control Channel
ODCH	ODMA Dedicated Channel
ODMA	Opportunity Driven Multiple Access
ORACH	ODMA Random Access Channel
ODTCH	ODMA Dedicated Traffic Channel
PCCH	Paging Control Channel
PCH	Paging Channel
PDU	Protocol Data Unit
PHY	Physical layer
PhyCH	Physical Channels
RACH	Random Access Channel

RLC	Radio Link Control
RNC	Radio Network Controller
RNS	Radio Network Subsystem
RNTI	Radio Network Temporary Identity
RRC	Radio Resource Control
SAP	Service Access Point
SCCH	Synchronization Control Channel
SCH	Synchronization Channel
SDU	Service Data Unit
SRNC	Serving Radio Network Controller
SRNS	Serving Radio Network Subsystem
TCH	Traffic Channel
TDD	Time Division Duplex
TFCI	Transport Format Combination Indicator
TFI	Transport Format Indicator
TMSI	Temporary Mobile Subscriber Identity
TPC	Transmit Power Control
U-	User-
UE	User Equipment
UE <sub>R</sub>	User Equipment with ODMA relay operation enabled
UL	Uplink
UMTS	Universal Mobile Telecommunications System
URA	UTRAN Registration Area
UTRA	UMTS Terrestrial Radio Access
UTRAN	UMTS Terrestrial Radio Access Network



## 4 Interfaces to the physical layer

The physical layer (layer 1) is the lowest layer in the OSI Reference Model and it supports all functions required for the transmission of bit streams on the physical medium.

The physical layer interfaces the Medium Access Control (MAC) Layer and the Radio Resource Control (RRC) Layer as depicted in figure 2.1.

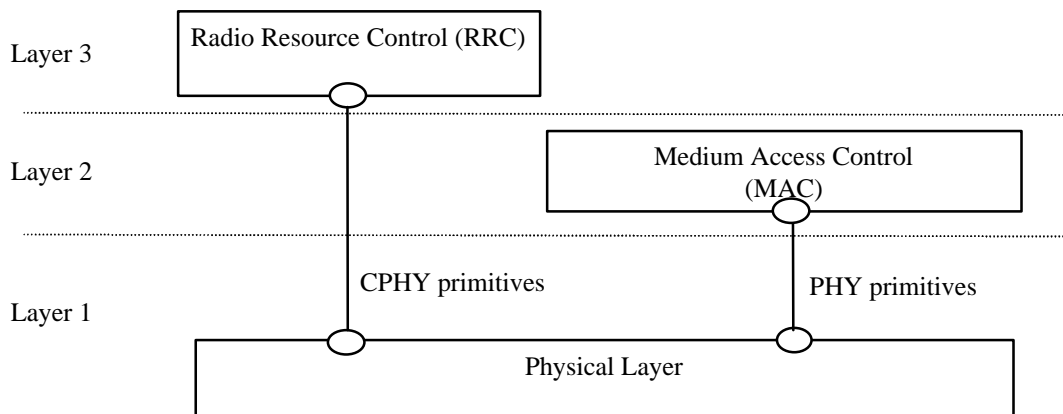

**Figure 1 : Interfaces with the Physical Layer**

### 4.1 Interface to MAC

The physical layer interfaces the MAC entity of layer 2.. Communication between the Physical Layer and MAC is in an abstract way performed by means of PHY-primitives defined which do not constrain implementations.

NOTE: The terms physical layer and layer 1, will be used synonymously in this description.

The PHY-primitives exchanged between the physical layer and the data link layer provide the following functions:

- transfer of transport blocks over the radio interface
- indicate the status of the layer 1 to layer 2

### 4.2 Interface to RRC

The physical layer interfaces the RRC entity of layer 3 in the UE and in the network.

Communication is performed in an abstract way by means of CPHY-primitives. They do not constrain implementations.

The CPHY-primitives exchanged between the physical layer and the Network layer provide the following function:

- control of the configuration of the physical layer

The currently identified exchange of information across that interface have only a local significance to the UE or Network.

## 5 Services and functions of the physical layer

### 5.1 General

The physical layer offers data transport services to higher layers. The access to these services is through the use of transport channels via the MAC sub-layer. The characteristics of a transport channel are defined by its transport format (or format set), specifying the physical layer processing to be applied to the transport channel in question, such as inner channel coding and interleaving, and any service-specific rate matching as needed.

The physical layer operates exactly according to the L1 radio frame timing. A transport block is defined as the data accepted by the physical layer to be jointly encoded. The transmission block timing is then tied exactly to this L1 frame timing, e.g. every transmission block is generated precisely every 10ms, or a multiple of 10 ms.

A UE can set up multiple transport channels simultaneously, each having own transport characteristics (e.g. offering different error correction capability). Each transport channel can be used for information stream transfer of one radio bearer or for layer 2 and higher layer signalling messages.

The multiplexing of these transport channels onto the same or different physical channels is carried out by L1. In addition, the Transport Format Combination Indication field (TFCI) shall uniquely identify the transport format used by each transport channel of the Coded Composite Transport Channel within the current radio frame.

## 5.2 Overview of L1 functions

The physical layer performs the following main functions:

- FEC encoding/decoding of transport channels
- Measurements and indication to higher layers (e.g. FER, SIR, interference power, transmission power, etc...)
- Macrodiversity distribution/combining and soft handover execution
- Error detection on transport channels
- Multiplexing of transport channels and demultiplexing of coded composite transport channels
- Rate matching
- Mapping of coded composite transport channels on physical channels
- Modulation and spreading/demodulation and despreading of physical channels
- Frequency and time (chip, bit, slot, frame) synchronization
- Closed-loop power control
- Power weighting and combining of physical channels
- RF processing

## 5.3 L1 interactions with L2 retransmission functionality

Provided that the RLC PDUs are mapped one-to-one onto the Transport Blocks, Error indication may be provided by L1 to L2. For that purpose, the L1 CRC can be used for individual error indication of each RLC PDU. The L1 CRC will then serve multiple purposes:

- Error indication for uplink macro diversity selection combining (L1)
- Frame error indication for speech services
- Quality indication
- Error indication for L2 retransmissions

As a conclusion, L1 needs to give an error indication to L2 for each erroneous Transport Block delivered.

# 6 Model of physical layer of the UE

## 6.1 Uplink models

[Figure 2](#) shows models of the UE's physical layer in the uplink for both FDD and TDD mode. It shows two models: DCH model and RACH model. Some restriction exist for the use of different types of transport channel at the same time, these restrictions are described in the chapter "UE Simultaneous Physical Channel combinations". More details can be found in [3] and [4].

*Editors note: Models for uplink transport channels currently marked ffs will be necessary if these channels are included in the description.*

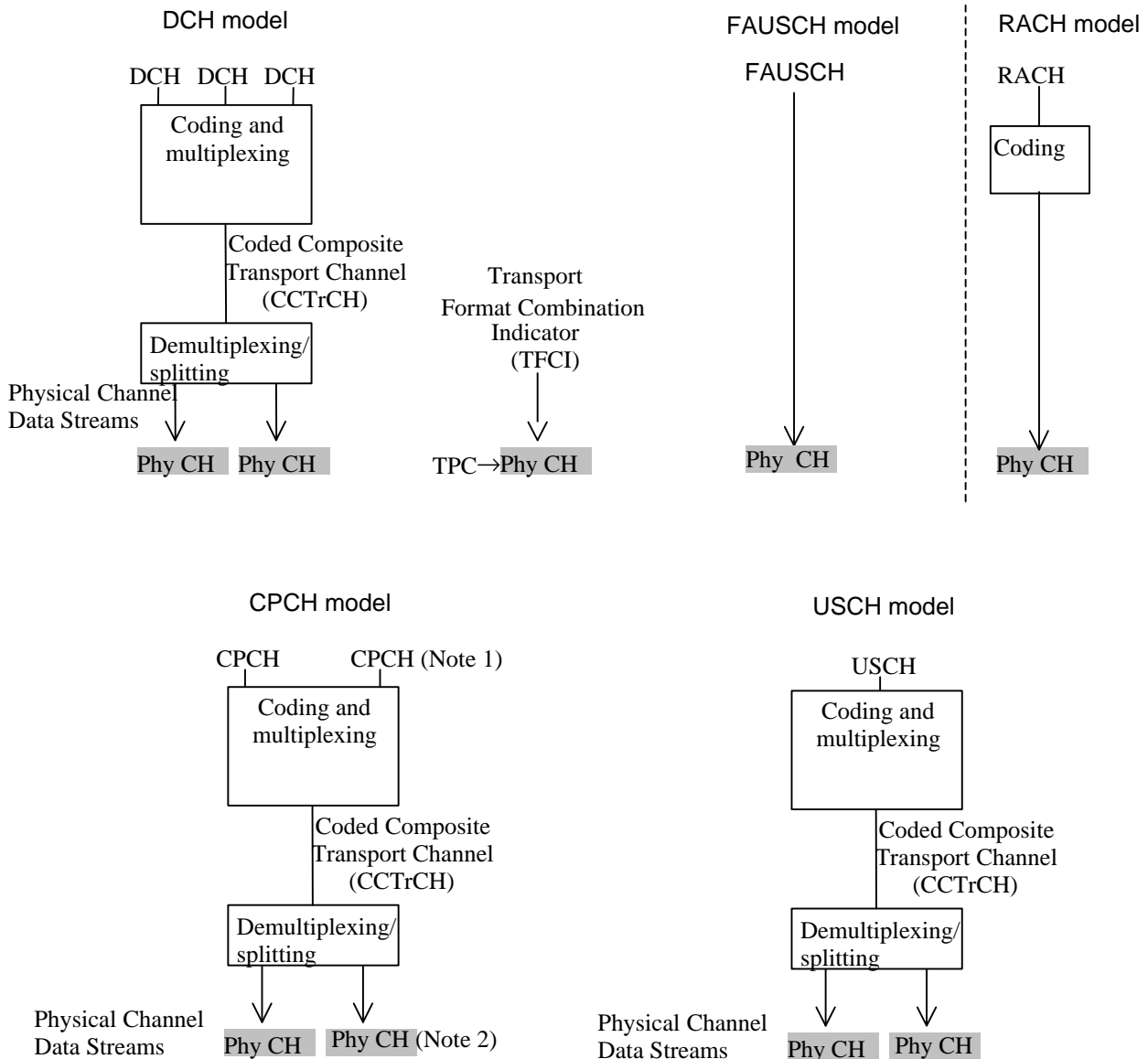

- Note 1: The need to multiplex several CPCH transport channels is FFS
- Note 2: Only the data part of the CPCH can be mapped on multiple physical channels
- Note 3: FAUSCH and CPCH are for FDD only.
- Note 4: USCH is for TDD only.

**Figure 2: Model of the UE's physical layer – uplink**

The DCH model shows that one or several DCHs can be processed and multiplexed together by the same coding and multiplexing unit. The detailed functions of the coding and multiplexing unit are not defined in this document but in [3] and [4]. The single output data stream from the coding and multiplexing unit is denoted *Coded Composite Transport Channel (CCTrCH)*.

The bits on a CCTrCH Data Stream can be mapped on the same Physical Channel and should have the same C/I requirement.

On the downlink, multiple CCTrCH can be used simultaneously with one UE. In the case of FDD, only one fast power control loop is necessary for these different CCTrCH, but the different CCTrCH can have different C/I requirements to provide different QoS on the mapped Transport Channels. In the case of TDD, different power control loops can be applied for different CCTrCH. One physical channel can only have bits coming from the same CCTrCH.

On the uplink and in the case of FDD, only one CCTrCH can be used simultaneously. On the uplink and in the case of TDD, multiple CCTrCH can be used simultaneously.

When multiple CCTrCH are used by one UE, one or several TFCI can be used, but each CCTrCH has only zero or one corresponding TFCI. In the case of FDD, these different words are mapped on the same DPCCCH. In the case of TDD, these different TFCI can be mapped on different DPCH.

The data stream of the CCTrCH is fed to a data demultiplexing/splitting unit that demultiplexes/splits the CCTrCH's data stream onto one or several *Physical Channel Data Streams*.

*Editors's note: The term "splitting" used for above function in FDD mode has been replaced by "demultiplexing/splitting". The intention of using the term splitting is to express that this function is performed on bit level not on some block level. The term demultiplexing/splitting shall cover both cases, block or bit level demultiplexing, where block lengths larger than 1 bit may be applied in the TDD mode. This needs to be confirmed by the L1 group*

The current configuration of the coding and multiplexing unit is either signalled to, or optionally blindly detected by, the network for each 10 ms frame. If the configuration is signalled, it is represented by the *Transport Format Combination Indicator (TFCI)* bits. Note that the TFCI signalling only consists of pointing out the current transport format combination within the already configured transport format combination set. In the uplink there is only one TFCI representing the current transport formats on all DCHs of one CCTrCH simultaneously. In FDD mode, the physical channel data stream carrying the TFCI is mapped onto the physical channel carrying the power control bits and the pilot.

For the FAUSCH, there is no coding, since the FAUSCH is only used for the transmission of a reservation request by sending an up-link signalling code (USC) at the time-offset allocated for the specific UE during the 10 ms frame. Due to the fixed time-offset allotted to a specific UE, the FAUSCH is a dedicated control channel.

The model for the RACH case shows that RACH is a common type transport channel in the uplink. RACHs are always mapped one-to-one onto physical channels, i.e. there is no physical layer multiplexing of RACH. Service multiplexing is handled by the MAC layer. The CPCH which is another common type transport channel has a physical layer model as shown in the above figure.

## 6.2 Downlink models

[Figure 3](#) and [Figure 4](#) show the model of the UE's physical layer for the downlink in FDD and TDD mode, respectively. Note that there is a different model for each transport channel type.

*Editors note: Models for downlink transport channels currently marked ffs will be necessary if these channels are included in the description.*

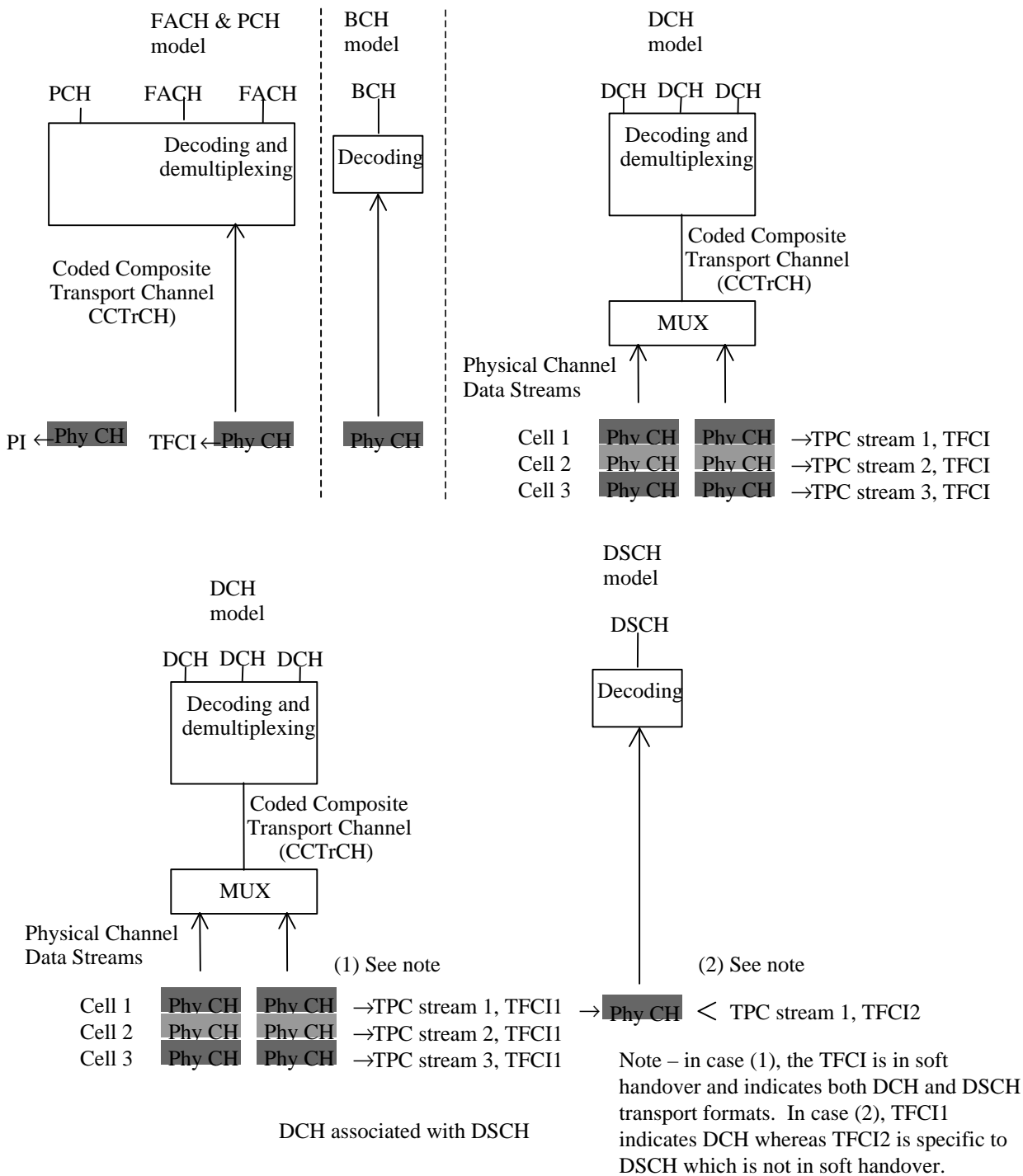

Figure 33: Model of the UE's physical layer – downlink FDD mode

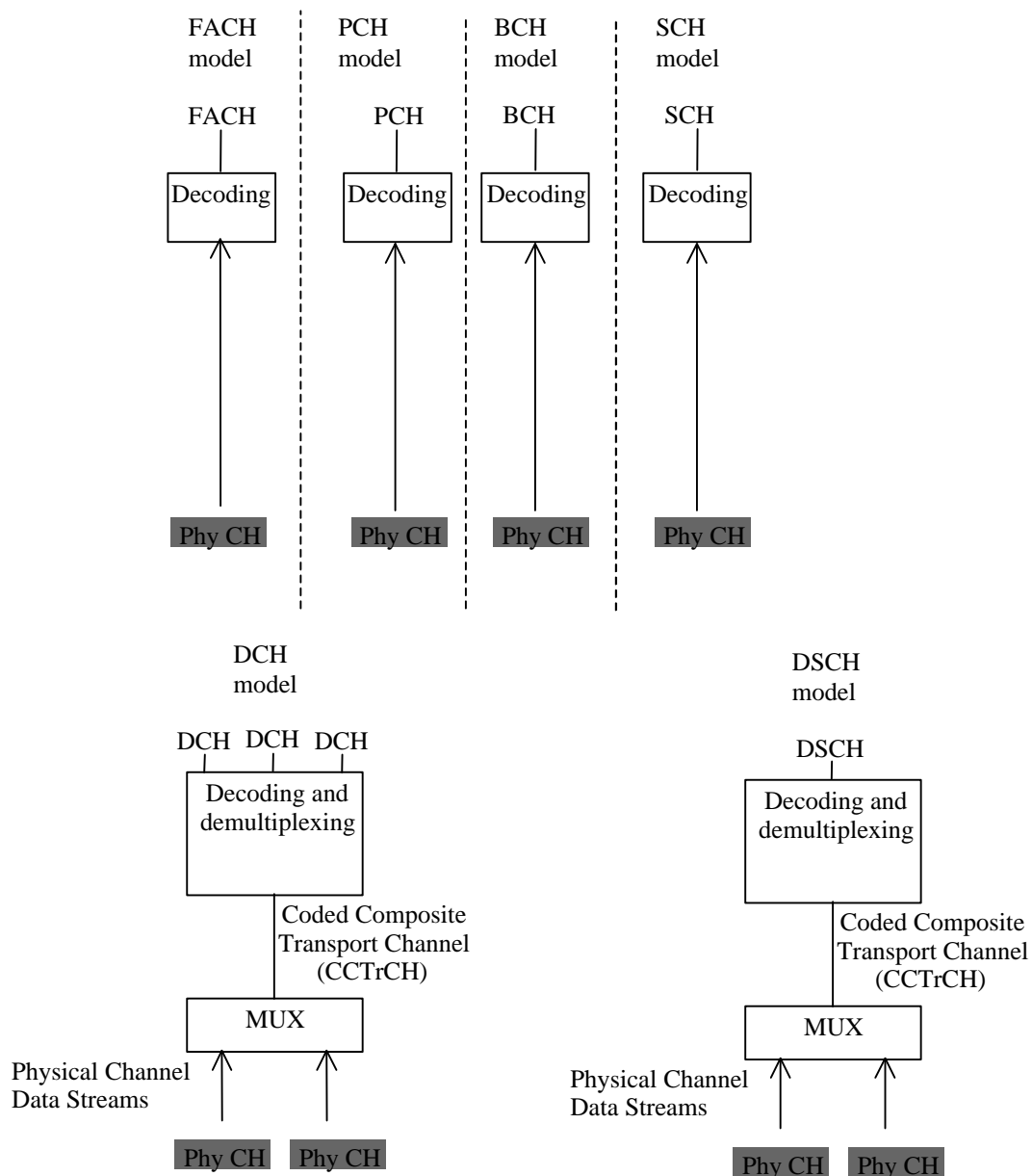

Figure 44: Model of the UE's physical layer – downlink TDD mode

For the DCH case, the mapping between DCHs and physical channel data streams works in the same way as for the uplink. Note however, that the number of DCHs, the coding and multiplexing etc. may be different in uplink and downlink.

In the FDD mode, the differences are mainly due to the soft and softer handover. Further, the pilot, TPC bits and TFCI are time multiplexed onto the same physical channel(s) as the DCHs. Further, the definition of physical channel data stream is somewhat different from the uplink.

Note that it is logically one and the same physical data stream in the active set of cells, even though physically there is one stream for each cell. The same processing and multiplexing is done in each cell. The only difference between the cells is the actual codes, and these codes correspond to the same spreading factor.

The physical channels carrying the same physical channel data stream are combined in the UE receiver, excluding the pilot, and in some cases the TPC bits. TPC bits received on certain physical channels may be combined provided that UTRAN has informed the UE that the TPC information on these channels is identical.

In the TDD mode, the downlink models for the BCH, PCH and FACH show that BCH, PCH and FACH are always mapped one-to-one onto physical channels, i.e. there is no physical layer multiplexing of BCH, PCH and FACH.

Service multiplexing is handled by the MAC layer. Note, in the TDD mode there is the SCH in addition (not shown in Figure 4).

In the FDD mode, a PCH and one or several FACH can be encoded and multiplexed together forming a CCTrCH. Similarly as in the DCH model there is one TFCI for each CCTrCH for indication of the transport formats used on each

PCH and FACH. The PCH is associated with a separate physical channel carrying page indicators (PIs) which are used to trigger UE reception of the physical channel that carries PCH. A FACH or a PCH can also be individually mapped onto a separate physical channel. The BCH is, as for TDD, always mapped onto one physical channel without any multiplexing with other transport channels.

## 6.3 Relay link Model

The Relay link applies to the TDD mode only. The applicability to the FDD mode is FFS. Figure 4 illustrates the model of the UE's physical layer for the TDD mode.

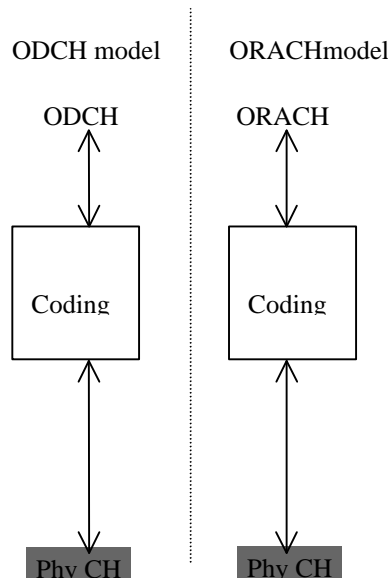

Figure 55 : Model of the UE's physical layer - relay link TDD mode.

The ORACH is a channel used within UE's to transmit and receive probing messages, and also to transmit and receive small packets of information. The ODCH is used to transmit larger amounts of data over a number of hops between UE's.

## 7 Formats and configurations for L1 data transfer

### 7.1 General concepts about Transport Channels

Layer 2 is responsible for the mapping of data onto L1 via the L1/L2 interface that is formed by the transport channels. In order to describe how the mapping is performed and how it is controlled, some definitions and terms are required. The required definitions are given in the following sections. Note that the definitions are generic for all transport channel types, i.e. not only for DCHs.

All Transport Channels are defined as unidirectional (i.e. uplink, downlink, or relay-link). This means that a UE can have simultaneously (depending on the services and the state of the UE) one or several transport channels in the downlink, and one or more Transport Channel in the uplink.

#### 7.1.1 Transport Block

This is the basic unit exchanged between L1 and MAC, for L1 processing. A Transport Block typically corresponds to an RLC PDU or corresponding unit. In the TDD mode it may possibly also be formed by a MAC peer-to-peer message. Layer 1 adds a CRC for each Transport Block.

#### 7.1.2 Transport Block Set

This is defined as a set of Transport Blocks which are exchanged between L1 and MAC at the same time instance using the same transport channel.

### 7.1.3 Transport Block Size

This is defined as the number of bits in a Transport Block.

### 7.1.4 Transport Block Set Size

This is defined as the number of bits in a Transport Block Set.

### 7.1.5 Transmission Time Interval

This is defined as the inter-arrival time of Transport Block Sets, and is equal to the periodicity at which a Transport Block Set is transferred by the physical layer on the radio interface. It is always a multiple of the minimum interleaving period (e.g. 10ms, the length of one Radio Frame). The MAC delivers one Transport Block Set to the physical layer every TTI.

Figure 6 shows an example where Transport Block Sets, at certain time instances, are exchanged between MAC and L1 via three parallel transport channels. Each Transport Block Set consists of a number of Transport Blocks. The Transmission Time Interval, i.e. the time between consecutive deliveries of data between MAC and L1, is also illustrated. Last, the case when the last Transport Block is smaller than the allowed size is shown, with the topmost Transport Block being partially empty.

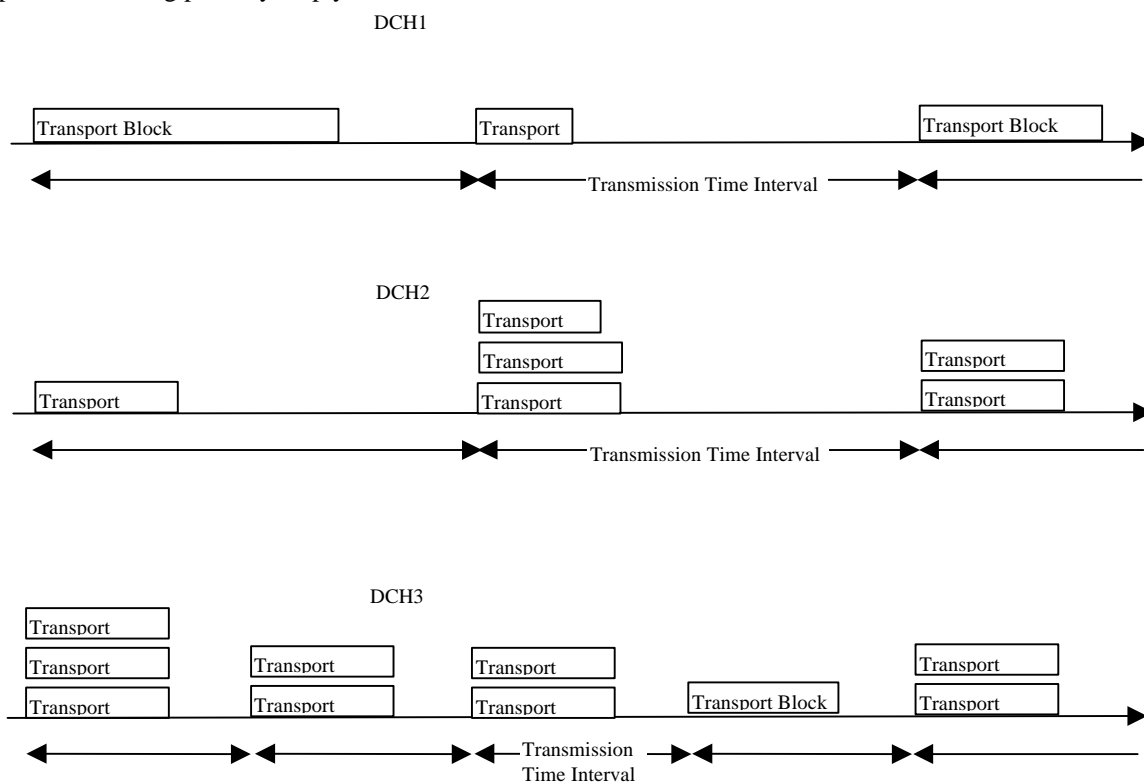

Figure 66. Exchange of data between MAC and L1

### 7.1.6 Transport Format

This is defined as a format offered by L1 to MAC (and vice versa) for the delivery of a Transport Block Set during a Transmission Time Interval on a Transport Channel. The Transport Format constitutes of two parts – one *dynamic* part and one *semi-static* part.

Attributes of the dynamic part are:

- Transport Block Size
- Transport Block Set Size
- Transmission Time Interval (optional dynamic attribute for TDD only)

Attributes of the semi-static part are:

- Transmission Time Interval (mandatory for FDD, optional for the dynamic part of TDD NRT bearers)
- Error protection scheme to apply



- Type of error protection e.g. Turbo Code, Convolutional Code
- convolutional code ratio
- Resulting code ratio after static rate matching
- Size of CRC

In the following example, the Transmission time Interval is seen as a semi-static part

Example:

- Dynamic part: {320 bits, 640 bits}, Semi-static part: {10ms, Inner coding only, repeat 1/12 of the bits}

### 7.1.7 Transport Format Set

This is defined as the set of Transport Formats associated to a Transport Channel.

The semi-static parts of all Transport Formats are the same within a Transport Format Set.

Effectively the first two attributes of the dynamic part form the instantaneous bit rate on the Transport Channel.

Variable bit rate on a Transport Channel may, depending on the type of service which is mapped onto the transport channel, be achieved by changing between each Transmission Time Interval one of the following:

1. the Transport Block Size only
2. the Transport Block Set Size only
3. both the Transport Block Size and the Transport Block Set Size

Example 1:

- Dynamic part: {20 bits, 20 bits}; {40 bits, 40 bits}; {80 bits, 80 bits}; {160 bits, 160 bits}
- Semi-static part: {10ms, Inner coding only, repeat 1/12 of the bits}

Example 2:

- Dynamic part: {320 bits, 320 bits}; {320 bits, 640 bits}; {320 bits, 1280 bits}
- Semi-static part: {10ms, Inner coding only, repeat 1/12 of the bits}

The first example may correspond to a Transport Channel carrying a speech service, requiring blocks delivered on a constant time basis. In the second example, which illustrates the situation where a non-real time service is carried by the Transport Channel, the number of blocks delivered per Transmission Time Interval varies between the different Transport Formats within the Transport Format Set. Referring to [Figure 6](#), the Transport Block Size is varied on DCH1 whereas the Transport Block Set Size is fix. That is, a Transport Format Set where the dynamic part has a variable Transport Block Size has been assigned for DCH1. On DCH2 and DCH3 it is instead the Transport Block Set Sizes that are varied. That is, the dynamic parts of the corresponding Transport Format Sets include variable Transport Block Set Sizes.

### 7.1.8 Transport Format Combination

The layer 1 multiplexes one or several Transport Channels, and for each Transport Channel, there exists a list of transport formats (Transport Format Set) which are applicable. Nevertheless, at a given point of time, not all combinations may be submitted to layer 1 but only a subset, the Transport Format Combination. This is defined as an authorised combination of the combination of currently valid Transport Formats that can be submitted simultaneously to the layer 1 for transmission on a Coded Composite Transport Channel of a UE, i.e. containing one Transport Format from each Transport Channel.

Example:

DCH1: Dynamic part: {20 bits, 20 bits}, Semi-static part: {10ms, Inner coding only, repeat 1/12 of the bits}

DCH2: Dynamic part: {320 bits, 1280 bits}, Semi-static part: {10ms, Inner coding only, puncture 1/14 of the bits}

DCH3: Dynamic part: {320 bits, 320 bits}, Semi-static part: {40ms, Outer coding, repeat 1/20 of the bits}

### 7.1.9 Transport Format Combination Set

This is defined as a set of Transport Format Combinations on a Coded Composite Transport Channel.

Example:

Dynamic part:

Combination 1: DCH1: {20 bits, 20 bits}, DCH2: {320 bits, 1280 bits}, DCH3: {320 bits, 320 bits}

Combination 2: DCH1: {40 bits, 40 bits}, DCH2: {320 bits, 1280 bits}, DCH3: {320 bits, 320 bits}

Combination 3: DCH1: {160 bits, 160 bits}, DCH2: {320 bits, 320 bits}, DCH3: {320 bits, 320 bits}

Semi-static part:

DCH1: {10ms, Inner coding only, repeat 1/12 of the bits}

DCH2: {10ms, Inner coding only, puncture 1/14 of the bits}

DCH3: {40ms, Outer coding, repeat 1/20 of the bits}

The Transport Format Combination Set is what is given to MAC for control. However, the assignment of the Transport Format Combination Set is done by L3. When mapping data onto L1, MAC chooses between the different Transport Format Combinations given in the Transport Format Combination Set. Since it is only the dynamic part that differ between the Transport format Combinations, it is in fact only the dynamic part that MAC has any control over.

The semi-static part, together with the target value for the L1 closed loop power control, correspond to the service attributes:

- Quality (e.g. BER)
- Transfer delay

These service attributes are then offered by L1. However, it is L3 that guarantees that the L1 services are fulfilled since it is in charge of controlling the L1 configuration, i.e. the setting of the semi-static part of the Transport Formats.

Furthermore, L3 controls the target for the L1 closed loop power control through the outer loop power control (which actually is a quality control rather than a power control).

Note that a Transport Format Combination Set need not contain all possible Transport Format Combinations that can be formed by Transport Format Sets of the corresponding Transport Channels. It is only the allowed combinations that are included. Thereby a maximum total bit rate of all transport channels of a Code Composite Transport Channel can be set appropriately. That can be achieved by only allowing Transport Format Combinations for which the included Transport Formats (one for each Transport Channel) do not correspond to high bit rates simultaneously.

The selection of Transport Format Combinations can be seen as a fast part of the radio resource control. The dedication of these fast parts of the radio resource control to MAC, close to L1, means that the flexible variable rate scheme provided by L1 can be fully utilised. These parts of the radio resource control should be distinguished from the slower parts, which are handled by L3. Thereby the bit rate can be changed very fast, without any need for L3 signalling.

### 7.1.10 Transport Format Indicator (TFI)

The TFI is a label for a specific transport format within a transport format set. It is used in the inter-layer communication between MAC and L1 each time a transport block set is exchanged between the two layers on a transport channel.

When the DSCH is associated with a DCH, the TFI of the DSCH also indicates the physical channel (i.e. the channelization code) of the DSCH that has to be listened to by the UE.

### 7.1.11 Transport Format Combination Indicator (TFCI)

This is a representation of the current Transport Format Combination.

There is a one-to-one correspondence between a certain value of the TFCI and a certain Transport Format Combination. The TFCI is used in order to inform the receiving side of the currently valid Transport Format Combination, and hence how to decode, de-multiplex and deliver the received data on the appropriate Transport Channels.

MAC indicates the TFI to Layer 1 at each delivery of Transport Block Sets on each Transport Channel. Layer 1 then builds the TFCI from the TFIs of all parallel transport channels of the UE, processes the Transport Blocks appropriately and appends the TFCI to the physical control signalling. Through the detection of the TFCI the receiving side is able to identify the Transport Format Combination. For FDD, in case of limited Transport Format Combination Sets the TFCI signalling may be omitted, instead relying on blind detection. Nevertheless, from the assigned Transport Format Combinations, the receiving side has all information it needs in order to decode the information and transfer it to MAC on the appropriate Transport Channels.

The multiplexing and exact rate matching patterns follow predefined rules and may therefore be derived (given the Transport Format Combinations) by transmitter and receiver without signalling over the radio interface.

When the meaning of the TFCI field needs to be reconfigured, two procedures can be used depending on the level of reconfiguration:

- **Complete reconfiguration of TFCI:** In this procedure all TFCI values are reinitialized and new values are defined instead. The complete reconfiguration requires an explicit synchronization between the UE and UTRAN regarding when the reconfiguration becomes valid.
- **Incremental reconfiguration of TFCI:** In this procedures, a part of the TFCI values before and after the reconfiguration remain identical (note that this must be true for at least a TFCI that carry the signaling connection). This procedure supports addition, removal or redefinition of TFCI values. This procedure does not require an explicit execution time. This procedure may imply the loss of some user-plane data.

### 7.1.12 Rate matching

Two levels of rate matching are defined on the radio interface:

- A static rate matching per Transport Channel. The static rate matching is part of the semi-static attributes of the Transport Channel
- A dynamic rate matching per CCTrCH. The dynamic rate matching adjusts the size of the physical layer data payload to the physical channel as requested by RRC.

The static rate matching and the dynamic rate matching to be applied by the physical layer are indicated by RRC to the physical layer.

RRC is responsible for configuring the physical layer on whether:

- Blind Rate Detection or TFCI is used
- Dynamic rate matching is applied or not on the downlink

## 7.2 Types of Transport Channels

A general classification of transport channels is into two groups:

- common channels and
- dedicated channels (where the UEs can be unambiguously identified by the physical channel, i.e. code and frequency)

Common transport channel types are:

1. Random Access Channel(s) (RACH) characterized by:

- existence in uplink only,
- limited data field. The exact number of allowed bits is FFS.
- collision risk,
- open loop power control,

2. ODMA Random Access Channel(s) (ORACH) characterized by:

- used in TDD mode only (FDD is for FFS)
- existence in relay-link
- collision risk,
- open loop power control,
- no timing advance control

3. Forward Access Channel(s) (FACH) characterized by:

- existence in downlink only,
- possibility to use beam forming,
- possibility to use slow power control,
- possibility to change rate fast (each 10ms),
- lack of fast power control and

4. Broadcast Channel (BCH) characterized by:

- existence in downlink only,
- low fixed bit rate and
- requirement to be broadcast in the entire coverage area of the cell.

5. Paging Channel (PCH) characterized by:

- existence in downlink only,
- association with a physical layer signal, the Page Indicator, to support efficient sleep mode procedures and
- requirement to be broadcast in the entire coverage area of the cell.

6. Synchronisation channel (SCH) characterised by :

- existence in TDD and downlink only
- low fixed bit rate
- requirement to be broadcast in the entire coverage area of the cell

7. Downlink Shared Channel(s) (DSCH) characterised by:

- existence in downlink only,

- possibility to use beamforming,
- possibility to use slow power control,
- possibility to use fast power control, when associated with dedicated channel(s)
- possibility to be broadcast in the entire cell
- always associated with another channel (DCH or DSCH Control Channel).

8. DSCH Control Channel characterised by:

- existence in downlink only,
- possibility to use beam forming,
- possibility to use slow power control,
- lack of fast power control

*Editor' s note: It is for further study whether or not the DSCH Control Channel needs to be regarded as separate transport channel type from FACH. Seen from the upper layers, the current requirements are identical to a FACH, but some extra L1 information (e.g.TPC bits) may lead to a different physical channel.*

9. CPCH Channel characterised by:

- existence in FDD only,
- existence in uplink only,
- fast power control on the message part,
- possibility to use beam forming,
- possibility to change rate fast,
- collision detection,
- open loop power estimate for pre-amble power ramp-up

9. Uplink Shared channel (USCH) characterised by:

- used in TDD only
- existence in uplink only,
- possibility to use beam forming,
- possibility to use power control,
- possibility to change rate fast

Dedicated transport channel types are:

1. Dedicated Channel (DCH) characterized by:

- existing in uplink or downlink
- possibility to use beam forming,
- possibility to change rate fast (each 10ms),
- fast power control

2. Fast Uplink Signaling Channel (FAUSCH) to allocate, in conjunction with FACH, dedicated channels; the FAUSCH is characterized by:

- existing in uplink only,
- inherent addressing of a UE by a unique time-offset (indicating to a UE when to send an uplink signalling code, USC) related to the beginning of the 10 ms frame,

- allowing for a UE to notify (by sending an USC) a request for a DCH, the allocation of which is messaged via the FACH. No further information is conveyed via the FAUSCH,
- applicability for TDD mode is FFS.

3. ODMA Dedicated Channel (ODCH) characterized by:

- used in TDD mode only (FDD is for FFS),
- possibility to use beam forming,
- possibility to change rate fast (each 10ms),
- closed loop power control,
- closed loop timing advance control

To each transport channel (except for the FAUSCH, since it only conveys a reservation request), there is an associated Transport Format (for transport channels with a fixed or slow changing rate) or an associated Transport Format Set (for transport channels with fast changing rate).

## 7.3 Slotted Mode

Slotted Mode is defined as the mechanism whereby certain idle periods are created in downlink radio frames so that the UE can perform measurement reports during these periods (more details can be found in [3]). Applicability to uplink is FFS.

Slotted Mode is obtained by layer 2 using transport channels provided by the layer 1 as follows :

- Slotted Mode is controlled by the RRC layer which configures the layer 2 and the physical layer
- The number of occurrences of slotted frames is controlled by RRC, and can be modified by RRC signalling
- Layer 2 instructs every Transmission Time Interval the Layer 1 on whether slotted mode should be applied for a given Transport Format Combination Set. The instruction may indicate also the type of slotted mode (beginning, middle or end of the frame).
- The slotting can be either cyclic (typically for circuit services) or a-periodic (typically for NRT services)
- It is under the responsibility of the layer 2 if necessary to either buffer some layer 2 PDUs (typically at the RLC layer for NRT services) or to rate adapt the data flow (similarly to GSM) so that there is no loss of data because of slotted mode. This will be service dependant and controlled by the RRC layer.

---

## 8 UE Simultaneous Physical Channels combinations

This sections describes the requirements from the UE to send and receive on multiple Transport Channels which are mapped on different physical channels simultaneously depending on the service capabilities and requirements. The section will describe the impacts on the support for multiple services (e.g. speech call and SMS-CB) depending on the UE capabilities.

*EDITOR'S NOTE : The following tables have been completed for FDD, the TDD operation will be addressed later.*

### 8.1 Uplink

The table describes the possible combinations of physical channels that can be supported in the uplink by one UE at any one time.

	<b>Physical Channel Combination</b>	Transport Channel Combination	<b>Baseline Capability or Service dependent</b>	<b>Comment</b>
1	PRACH	RACH	Baseline	The PRACH physical channel includes the preambles and the message.
2	PRACH	FAUSCH	Service dependent	
3	PCPCH consisting of one control and one data part during the message portion	CPCH	Service dependent	The PCPCH physical channel includes the preambles and the message. The maximum channel bit rate is dependant on UE Service Capability
4	PCPCH consisting of one control and more than one data part during the message portion	CPCH	Service dependent	The PCPCH physical channel includes the preambles and the message. The maximum channel bit rate is dependant on UE Service Capability
5	DPCH consisting of one DPCCH and one DPDCH	One or more DCH coded into a single CCTrCH	Service dependent	The maximum number of DCHs and the maximum channel bit rate are dependant on UE Service Capability
6	DPCH consisting of one DPCCH and more than one DPDCH	One or more DCH coded into a single CCTrCH	Service dependent	The maximum number of DCHs and the maximum channel bit rate are dependant on UE Service Capability

## 8.2 Downlink

The table describes the possible combinations of physical channels that can be supported in the downlink by one UE at any one time.

	Physical Channel Combination	Transport Channel Combination	Baseline Capability or Service dependent	Comment
1	PCCPCH	BCH	Baseline	
2	SCCPCH	FACH + PCH	Baseline	The maximum channel bit rate that can be supported is dependent on the UE Service Capability
3	SCCPCH + AICH	FACH + PCH + RACH in uplink Or FACH + PCH + CPCH in uplink	FFS	The maximum channel bit rate that can be supported is dependent on the UE Service Capability. This physical channel combination facilitates the preamble portion of the CPCH in the uplink <i>See note 1</i>
4	SCCPCH + DPCCH	FACH + PCH + CPCH in uplink	Service dependent	This physical channel combination facilitates the message portion of the CPCH in the uplink
5	More than one SCCPCH	More than one FACH + PCH	Service dependent	
6	PICH	N/A	Baseline	
7	DPCCH + DPDCH	One or more DCH coded into a single CCTrCH	Service dependant	The maximum number of DCHs and the maximum channel bit rate are dependent on UE Service Capability
8	DPCCH + more than one DPDCH	One or more DCH coded into a single CCTrCH	Service dependent	The maximum number of DCHs and the maximum channel bit rate are dependent on UE Service Capability
9	PDSCH + DPCCH + one or more DPDCH	DSCH + one or more DCH coded into a single CCTrCH	Service dependent	The maximum number of DCHs and the maximum channel bit rate are dependent on UE Service Capability
10	SCCPCH + DPCCH + one or more DPDCH	FACH + one or more DCH coded into a single CCTrCH	Service dependent	The maximum number of DCHs and the maximum channel bit rate are dependent on UE Service Capability This combination of physical channels is used for DRAC control of an uplink DCH and for receiving services such as cell broadcast or multicast whilst in connected mode.
11	SCCPCH + PDSCH + DPCCH + one or more DPDCH	FACH + DSCH + one or more DCH coded into a single CCTrCH	Service dependent	The maximum number of DCHs and the maximum channel bit rate are dependent on UE Service Capability This combination of physical channels is used for simultaneous DSCH and DRAC control of an uplink DCH.
12	More than one DPCCH + more than one DPDCH	More than one DCH coded into one or more CCTrCH	Service dependent	<i>See note 2</i>

Notes:

1 Whether the support of simultaneous AICH and SCCPCH is part of the UE baseline implementation capabilities is still under discussion within TSG RAN WG1.

2 The use of more than one DPCCH and/or more than one CCTrCH are currently for FFS within TSG RAN WG1.

## 9 Measurements provided by the physical layer

One of the key services provided by the physical layer is the measurement of various quantities which are used to trigger or perform a multitude of functions. Both the UE and the UTRAN are required to perform a variety of measurements. The standard will not specify the method to perform these measurements or stipulate that the list of measurements provided in this section must all be performed. While some of the measurements are critical to the functioning of the network and are mandatory for delivering the basic functionality (e.g., handover measurements,

power control measurements), others may be used by the network operators in optimising the network (e.g., radio environment).

Measurements may be made periodically and reported to the upper layers or may be event-triggered (e.g., primary CCPCH becomes better than the previous best primary CCPCH. The measurements are tightly coupled with the service primitives in that the primitives' parameters may constitute some of the measurements.

The list and frequency of measurements which the physical layer reports to higher layers is described in this section.

*EDITOR'S NOTE: These measurements are considered equally applicable to FDD and TDD modes., however, the applicability of all measurements to the TDD mode needs to be reviewed.*

*EDITOR'S NOTE: The measurements CCPCH Rx SIR and CCPCH Rx ISCP should be reviewed by WG1 for practicality in the UE and WG2 informed of the implications of these measures being mandatory.*

The measurement quantities measured by the physical layer shall be such that the following principles are applied:

For handover measurements, the decoding of parameters on the BCCH logical channel of monitored neighbouring cells, should not, in general, be needed for calculating the measurement result. If there is a need to adjust the measurement result with parameters broadcast on the PCCPCH, these parameters shall be provided by the UTRAN in inband measurement control messages. There may be some exceptions to this rule. *For example, it may be necessary to decode the SFN of the measured neighbouring cell for time difference measurements. [Note: It should be clarified whether the SFN is a L3 or L1 parameter.]*

In idle mode or in RRC connected mode using common Transport Channels, the UE shall be able to monitor cells for cell reselection, without being required to frequently decode parameters on the BCCH logical channel of the monitored neighbouring cells. The decoding frequency of these parameters, set by the cell reselection algorithm, should be such that UE standby times are not significantly decreased.

## 9.1 Measurements of downlink channels

### 9.1.1 CFN-SFN Observed time difference

This measure is mandatory for the UE.

Measurement	Measured time difference to UTRA cell
Source	L1 (UE)
Destination	RRC (RNC) for handover
Reporting Trigger	On-demand, Event-triggered
Definition	<b><i>The CFN-SFN Observed time difference to cell indicates the time difference which is measured by UE between CFN in the UE and the SFN of the target neighbouring cell. It is notified to SRNC by Measurement Report message or Measurement Information Element in other RRC messages.</i></b>
Precision Requirement	<b><i>For handover, precision to [1] chip unit</i></b>

### 9.1.2 Observed time difference to GSM cell

This measure is mandatory for the UE if the handover to GSM service is to be supported.

Measurement	Measured time difference to GSM cell
Source	L1 (UE)
Destination	RRC (RNC) for maintenance and handover to GSM
Reporting Trigger	On-demand, Event-triggered
Definition	<b><i>Time difference between the Primary CCPCH of the current cell and the timing of the GSM cell.</i></b>
Precision Requirement	<b><i>For handover, precision to [x] microseconds</i></b>

### 9.1.3 Primary CCPCH RX $E_c/I_0$

This measure is mandatory for the UE.



Measurement	primary CCPCH Rx Ec/Io
Source	L1(UE)
Destination	RRC (UE, RNC),
Reporting Trigger	Periodic, on demand and event triggered
Definition	$-20\log_{10}(E_c/I_o)$ where $E_c$ is the energy per chip of the Primary CCPCH measured in the searcher and $I_o$ is the received spectral density.
Precision Requirement	1 dB

### 9.1.4 Primary CCPCH Rx SIR

This measure is mandatory for the UE.

Measurement	Primary CCPCH Rx SIR
Source	L1 (UE)
Destination	RRC (UE, RNC)
Reporting Trigger	periodic or event triggered
Definition	<b><i>This quantity is a ratio of the Primary CCPCH Received Signal Code Power (RSCP) to the Interference Signal Code Power (ISCP). The RSCP is the measured symbol power of the Primary CCPCH at the demodulator output and the ISCP is the measured interference symbol power.</i></b>
Precision Requirement	1 dB

### 9.1.5 Primary CCPCH Rx RSCP

This measure is mandatory for the UE.

Measurement	Primary CCPCH Rx RSCP
Source	L1(UE)
Destination	RRC (UE, RNC)
Reporting Trigger	periodic or event triggered
Definition	<b><i>Received Signal Code Power, is received power on one code after despreading, defined on the pilot symbols.</i></b>
Precision Requirement	1 dB

### 9.1.6 Primary CCPCH Rx ISCP

This measure is mandatory for the UE.

Measurement	Primary CCPCH Rx ISCP
Source	L1(UE)
Destination	RRC (UE, RNC)
Reporting Trigger	periodic or event triggered
Definition	<b><i>Interference on Signal Code Power, is the interference on the mentioned received signal after despreading. Thereby only the non-orthogonal part of the interference is included.</i></b>
Precision Requirement	1 dB

### 9.1.7 DPCCH SIR

This measure is mandatory for the UE.

Measurement	DPCCH SIR
Source	L1(UE)
Destination	RRC(UE,RNC)
Reporting Trigger	Periodic, once every power control slot for DPCCH
Definition	The ratio of the measured symbol power at the demodulator output to the measured interference power at the demodulator output.
Precision Requirement	<u>less than the</u> minimum DL power control step size

### 9.1.8 UTRA Cell Signal strength (RSSI)

This measure is mandatory for the UE.

Measurement	signal strength
Source	L1(UE)
Destination	RRC (RNC),
Reporting Trigger	Periodic, event triggered, on demand
Definition	Received Signal Strength Indicator, the wideband received power within the channel bandwidth averaged over [1 s] interval.
Precision Requirement	1 dB

### 9.1.9 Alternate mode Signal strength

#### 9.1.9.1 GSM Signal Strength

This measure is mandatory for the UE if the service handover to GSM is to be supported.

Measurement	GSM signal strength
Source	L1(UE)
Destination	RRC (RNC)
Reporting Trigger	Periodic, event triggered, on demand
Definition	reference GSM document 05.08
Precision Requirement	reference GSM document 05.08

#### 9.1.10 Transport CH BLER

This measure is mandatory for the UE.

Measurement	transport channel BLER (BLock Error Rate)
Source	L1(UE)
Destination	RRC(RNC,UE)
Reporting Trigger	periodic
Definition	The error detection mechanism will determine whether or not a block error occurred.
Precision Requirement	Transport channel dependent

#### 9.1.11 Physical CH BER

This measure is mandatory for the UE.

Measurement	physical channel BER
Source	L1(UE)
Destination	RRC(UE,RNC)
Reporting Trigger	On-demand, Event-triggered
Definition	The estimate of the raw BER of the physical channel calculated only on the data part.
Precision Requirement	[10%]

### 9.1.12 Total Tx Power

Measurement	total Tx power
Source	L1(Node-B)
Destination	RRC(RNC)
Reporting Trigger	On-demand, periodic, Event-triggered
Definition	The total power emitted by the Node-B within the channel bandwidth averaged over an interval of [1 s]
Precision Requirement	1 dB

### 9.1.13 Code Tx Power

Measurement	Code Tx power
Source	L1(Node-B)
Destination	RRC (RNC)
Reporting Trigger	On-demand, periodic, Event-triggered
Definition	The total power emitted by the Node-B on one channelisation code for one UE averaged over [100 ms]
Precision Requirement	1 dB

## 9.2 Measurements on uplink channels

### 9.2.1 UL load

Measurement	UL load
Source	L1 (Node B)
Destination	RRC(RNC)
Reporting Trigger	On-demand, Event-triggered, Periodic
Definition	the total received signal power for a carrier within the cell
Precision Requirement	1 dB

### 9.2.2 UE Tx Power

This measure is mandatory for the UE.

Measurement	UE Tx power
Source	L1(UE)
Destination	RRC (UE,RNC)
Reporting Trigger	On-demand, periodic, Event-triggered
Definition	RRC (UE) – the total Tx power, measured at the antenna connector, averaged over [100 ms] RRC (RNC) – indication of Tx power reaching threshold (for example, upper or lower power limits)
Precision Requirement	3 dB

### 9.2.3 Transport CH BLER

Measurement	transport channel BLER (BLock Error Rate)
Source	L1(Node-B)
Destination	RRC(RNC)
Reporting Trigger	periodic, event triggered, on demand
Definition	The error detection mechanism will determine whether or not a block error occurred.
Precision Requirement	Transport channel dependent

### 9.2.4 Physical CH BER

Measurement	physical channel BER
Source	L1(Node-B)
Destination	RRC(RNC)
Reporting Trigger	On-demand, Event-triggered, periodic
Definition	The estimate of the raw BER of the physical channel calculated only on the data part.
Precision Requirement	[10%]

## 9.3 Miscellaneous measurements

### 9.3.1 Time of Arrival (TOA)

The Time of Arrival (TOA) measurement at a single node-B may provide an estimate of the round trip time of signals between the Node-B and the UE and this may be used to calculate a radial distance to the UE within the sector. A group of simultaneous TOA measurements made from a number of Node-B or LMU may be used to estimate the location of the UE. This support for this measurement is LCS positioning method dependant..

Measurement	Time of arrival (TOA)
Source	L1(Node-B or LMU)
Destination	RRC (RNC-LCS)
Reporting Trigger	on demand, event triggered
Definition	the time of arrival of the uplink transmissions in relation to the CCPCH timing reference..
Precision Requirement	[ 0,5 ] chip

### 9.3.2 SFN-SFN Observed time difference

The SFN-SFN observed time difference at the UE of a group of Node-B may be used for location calculation. . The applicability of this measure is LCS method dependent This support for this measurement is LCS positioning method dependant.

Measurement	SFN-SFN observed time difference
Source	L1 (UE)
Destination	RRC (RNC) for handover, maintenance and LCS
Reporting Trigger	On-demand, Event-triggered
Definition	<b><i>Time difference between the Primary CCPCH of the current cell and the Primary CCPCH of a neighboring cell.</i></b>
Precision Requirement	<b><i>For LCS, precision to a fraction of a chip</i></b>

### 9.3.3 Frequency Offset (FO)

The Frequency Offset (FO) measures the rate of change (drift) of the Relative Time Difference and may be used to estimate the RTD at the time the UE location measurements are made. . This support for this measurement is LCS positioning method dependant.

Measurement	Frequency Offset (FO)
Source	L1( LMU)
Destination	RRC (RNC-LCS)
Reporting Trigger	On demand, event triggered, periodic
Definition	The Frequency Offset (FO) measures the rate of change (drift) of the Relative Time Difference of the CCPCH transmissions of two Node-B.
Precision Requirement	[ 1 ] Hz

## 10 Primitives of the physical layer

The Physical layer interacts with other entities as illustrated in figure 2.1. The interactions with the MAC layer and the RRC layer are shown in terms of primitives where the primitives represent the logical exchange of information and control between the physical layer and higher layers. They do not specify or constrain implementations. The (adjacent) layers connect to each other through Service Access Points (SAPs). Primitives, therefore, are the conveyer of the information exchange and control through SAPs.

Three types of primitives are used for this document, as follows.

### REQUEST

This type is used when a higher layer is requesting a service from a lower layer.

### - INDICATION:

This type is used by a lower layer providing a service to notify its higher layer of activities concerning that higher layer.

### - CONFIRM:

This type is used by a lower layer providing the requested service to confirm to the higher layer that the activity has been completed.

The primitives defined below are for local communications between MAC and L1, as well as RRC and L1 in the same protocol stack.

For the physical layer two sets of primitives are defined:

#### \* Primitives between layer 1 and 2:

PHY - Generic name - Type: Parameters.

#### \* Primitives between layer 1 and the RRC entity:

CPHY - Generic name - Type: Parameters.

*EDITOR'S NOTE : This is a logical description of the primitives and does not cover addressing aspects (e.g. Transport Channel ID, Physical Channel ID, start frame number or disconnect frame number).*

### 10.1 Generic names of primitives between layers 1 and 2

The primitives between layer 1 and layer 2 are shown in the Table 1.

**Table 1. Primitives between layer 1 and 2**

Generic Name	Parameters
<b>PHY-DATA-REQ</b>	TFI, compressed mode type, TBS
<b>PHY-DATA-IND</b>	TFI, compressed mode type, TBS, CRC result
<b>PHY-STATUS-IND</b>	Event value

#### 10.1.1 PHY-Data-REQ

The PHY-DATA primitives are used to request SDUs used for communications passed to and from the physical layer. One PHY-DATA primitive is submitted every Transmission Time Interval for each Transport Channel.

**Primitive Type:** request.

#### Parameters:

- TFI
- Type of compressed mode (e.g. uncompressed, compressed with beginning/middle/end of frame)
- Transport Block Set

- $FN_{CELL}$
- Page indicators (PIs) ( PCH only)

### 10.1.2 PHY- Data-IND

The PHY-DATA primitives are used to indicate SDUs used for Layer 2 passed to and from the physical layer. One PHY-DATA primitive is submitted every Transmission Time Interval for each Transport Channel.

**Primitive Type:** indicate

**Parameters:**

- TFI
- Type of compressed mode (e.g. uncompressed, compressed with beginning/middle/end of frame)
- Transport Block Set
- CRC check result

### 10.1.3 10.1.3 PHY-Status-IND

The PHY-STATUS primitive can be used by the layer 1 to notify higher layers of an event which has occurred.

**Primitive Type:** indication

**Parameters**

- Event value

## 10.2 Generic names of primitives between layers 1 and 3

The status primitives between layer 1 and 3 are shown in the Table 2.

**Table 2: Status primitives between layer 1 and 3**

Generic Name	Parameters
<b>CPHY-Sync-IND</b>	none
<b>CPHY-Out-of-Sync-IND</b>	none
<b>CPHY-Measurement-REQ</b>	Measurement parameters
<b>CPHY-Measurement-IND</b>	Measurement parameters
<b>CPHY-ERROR-IND</b>	Error Code

### 10.2.1 STATUS PRIMITIVES

#### 10.2.1.1 CPHY-Sync-IND

This primitive is used for L1 to indicate to RRC that synchronisation of a certain physical channel has been done in the receiver. In FDD synchronization is based on reception of the DPCCH, and in TDD synchronization is based on midamble reception.

**Primitive Type:** indication

**Parameters:**

- none

### 10.2.1.2 CPHY-Out-of-Sync-IND

Primitive sent from L1 to RRC indicating that synchronisation of a previously configured connection has been lost in the receiver. In FDD synchronization is based on reception of the DPCCH, and in TDD synchronization is based on midamble reception.

**Primitive Type:** indication

**Parameters:**

- none

### 10.2.1.3 CPHY-Measurement-REQ

The Request primitive is used for RRC to configure L1 measurements.

**Primitive Type:** request

**Parameters:**

- transmission power threshold
- Refer to section 9 for measurement parameters

### 10.2.1.4 CPHY-Measurement-IND

The Indication primitive is used to report the measurement results

**Primitive Type:** indication

**Parameters:**

- **Refer to Section 9 for measurement parameters**

### 10.2.1.5 CPHY-ERROR-IND

The CPHY-ERROR primitive is used to indicate to the management entity that an error has occurred as a result of a physical layer fault.

**Primitive Type:** indication

**Parameters**

- Error Code

## 10.2.2 CONTROL PRIMITIVES

The control primitives between layer 1 and 3 are shown in the Table 3



**Table 3. Control primitives between layer 1 and 3**

Generic Name	Parameters
<b>CPHY-TrCH-Config-REQ</b>	Transport channel description,
<b>CPHY-TrCH-Config-CNF</b>	
<b>CPHY-TrCH_Release-REQ</b>	
<b>CPHY-TrCH_Release-CNF</b>	
<b>CPHY-RL-Setup-REQ</b>	Physical channel description
<b>CPHY-RL-Setup-CNF</b>	none
<b>CPHY-RL-Release-REQ</b>	none
<b>CPHY-RL-Release-CNF</b>	none
<b>CPHY-RL-Modify-REQ</b>	Physical channel description
<b>CPHY-RL-Modify-CNF</b>	none
<b>CPHY-Commit-REQ</b>	Activation Time

### 10.2.2.1 CPHY-TrCH-Config-REQ

This primitive is used for setting up and configuring a transport channel, and also to modify an existing transport channel.

**Primitive Type: request**

**Parameters:**

- Transport channel description

### 10.2.2.2 CPHY-TrCH-Config-CNF

This primitive is used for confirming the setting up and configuring a transport channel, and also modifying an existing transport channel.

**Primitive Type: confirm**

**Parameters:**

- none

### 10.2.2.3 CPHY-TrCH-Release-REQ

This primitive is used for releasing a transport channel.

**Primitive Type: request**

**Parameters:**

- none

### 10.2.2.4 CPHY-TrCH-Release-CNF

This primitive is used for confirming the releasing a transport channel.

**Primitive Type: confirm**

**Parameters:**

- none

#### 10.2.2.5 CPHY-RL-Setup-REQ

The Request primitive is sent from RRC to L1 for establishment of a Radio link to a certain UE.

**Primitive Type: request**

**Parameters:**

- Physical channel description

#### 10.2.2.6 CPHY-RL-Setup-CNF

The Confirm primitive is returned from L1 to RRC when the Radio link is established. In case L1 is unable to execute the request, this is indicated in the confirm primitive.

**Primitive Type: confirm**

**Parameters:**

- none

#### 10.2.2.7 10.2.7 CPHY-RL-Release-REQ

The Request primitive is sent from RRC to L1 for release of a Radio link to a certain UE.

**Primitive Type: request**

**Parameters:**

- none

#### 10.2.2.8 CPHY-RL-Release-CNF

The Confirm primitive is returned from L1 to RRC when the radio link is released.

**Primitive Type: confirm**

**Parameters:**

- none

#### 10.2.2.9 CPHY-Modify-REQ

The Request primitive is sent from RRC to L1 for modification of a Radio link to a certain UE.

**Primitive Type: request**

**Parameters:**

- Physical channel description

#### 10.2.2.10 CPHY-RL-Modify-CNF

The Confirm primitive is returned from L1 to RRC when the radio link is modified. In case L1 is unable to execute the request, this is indicated in the confirm primitive.

**Primitive Type: confirm**

**Parameters:**

- none

#### 10.2.2.11 10.2. 11 CPHY-Commit-REQ

This primitive is sent from RRC to L1 to synchronise UE and NW for the physical channel modification.

**Primitive Type: request**

**Parameters:**

- Activation time

## 10.3 Parameter definition

### 10.3.1 Error code

- Hardware failure

## 10.3.2 Event value

- Maximum transmission power has been reached
- Allowable transmission power has been reached
- Average transmission power is below allowable transmission power

## 10.3.3 Physical channel description

*EDITOR'S NOTE: The applicability of these parameters to TDD remains FFS.*

### 10.3.3.1 Primary SCH

- Tx diversity mode

### 10.3.3.2 Secondary SCH

- Tx diversity mode

### 10.3.3.3 Primary CCPCH

- Frequency info
- DL scrambling code
- Tx diversity mode

### 10.3.3.4 Secondary CCPCH

- DL scrambling code
- Channelisation code
- Tx diversity mode

### 10.3.3.5 PRACH

*Editor's note: The PRACH can also be used to map the FAUSCH Transport Channel*

- Access Slot
- Preamble spreading code
- Preamble signature
- Message channelisation code(Spreading factor)
- Power control info
  - UL target SIR
  - Primary CCPCH DL TX Power
  - UL interference
  - Power offset (Power ramping)
- Access Service Class Selection
  - Preamble signature classification information
- AICH transmission timing parameter
- Persistence value

### 10.3.3.6 Uplink DPCH

- UL scrambling code
- DPCCH Channelisation code
- DPDCH Channelisation code
- DPCCH Gate rate
- DPCCH slot structure ( $N_{\text{pilot}}$ ,  $N_{\text{TPC}}$ ,  $N_{\text{TFCI}}$ ,  $N_{\text{FBI}}$ )
- Transmission Time offset value

### 10.3.3.7 Downlink DPCH

- Transmission Time offset value
- DPCCH Gate rate
- DL scrambling code
  - DL Channelisation code
- Tx diversity mode

- FB mode
- Slot structure ( $N_{\text{pilo}}$ ,  $N_{\text{TPC}}$ ,  $N_{\text{TFCI}}$ ,  $N_{\text{FBI}}$ ,  $N_{\text{data1}}$ ,  $N_{\text{data2}}$ )

### 10.3.3.8 PCPCH (Physical Common Packet Channel)

- CPCH Set ID to which this CPCH belongs.
- UE Access Preamble (AP) code
- DL AP-AICH Channelisation code
- UL CD preamble code
- DL CD-AICH Channelisation code
- CPCH UL scrambling code
- CPCH UL Channelisation code
- DPCCH DL Channelisation code
- Data rate (spreading factor)
- $N_{\text{frames\_max}}$ : Maximum packet length in frames
- Persistency value ( $PV_{\text{cpch}}$ )
- Signature set: set of preamble signatures for AP to access this CPCH

### 10.3.3.9 PICH

- Scrambling code
- Channelisation code

### 10.3.3.10 AICH

- Scrambling code
- Channelisation code
- Tx diversity mode

*Editor's Note: the value for the parameters need to be consistent with the corresponding PRACH. This needs to be confirmed by WGI.*

### 10.3.3.11 PDSCH

- Scrambling code
- Chnnelisation code
- Tx diversity mode
  - FB mode

### 10.3.3.12 PUSCH

*Editor's Note: the characteristics of the PUSCH are under review for TDD.*

## 10.3.4 Transport channel description

# 11 Radio Frame transmission

## 11.1 Downlink Frame format

## 11.2 Uplink Frame format

## 11.3 Order of bit transmission

## Annex A: Description of Transport Formats

The following table describes the characterisation of a Transport Format. The possible values for the attributes will be defined by the L1 experts group based on the requirements identified by the L23 experts group. Note that the allowed Transport Format Combinations are not described here, and will need to be covered also.

		Attribute values
Dynamic part	Transport Block Size	1 to 5000 1 bit granularity
	Transport Block Set Size	1 to 200000 1 bit granularity
	Transmission Time Interval (option for TDD only)	10, 20 ms, 40 and 80 ms
Semi-static part	Transmission Time Interval (FDD, option for TDD NRT bearers)	10, 20 ms, 40 and 80 ms
	Type of channel coding	Turbo Convolutional coding
	code rates	1/2, 1/3
	CRC size	0, 8, 16, 24
	Resulting ratio after static rate matching	0.5 to 4

Note: The maximum size of the Transport Block has been chosen so as to avoid any need for segmentation in the physical layer into sub-blocks (segmentation should be avoided in the physical layer).

## Annex B (Informative): Example of Transport format attributes for AMR speech codec

The support for the AMR speech codec is exemplified below. On the radio interface, one Transport Channel is established per class of bits i.e. DCH A for class A, DCH B for class B and DCH C for class C. Each DCH has a different transport format combination set which corresponds to the necessary protection for the corresponding class of bits as well as the size of these class of bits for the various AMR codec modes.

With this principle, the AMR codec mode which is used during a given TTI can be deduced from the format of the transport channels DCH A, DCH B and DCH C for that particular TTI.

Note that a similar principle can also be applied for other source codecs e.g. other speech codecs or video codecs. An example of transport channel description for each class of bits is given below:

	Attribute	Value		
		Class A	Class B	Class C
Dynamic part	Transport Block Size	81	103	60
		65	99	40
		75	84	0
		61	87	0
		55	79	0
		55	63	0
		49	54	0
		39	56	0
	Transport Block Set Size	Same as the transport block sizes		
	Transmission Time Interval (option for TDD only)			
Semi-static part	Transmission Time Interval (FDD)	20 ms		
	Type of channel coding	Convolutional coding		
	code rates	1/2, 1/3 + class-specific rate matching	None, 1/2, 1/3 + class-specific rate matching	None, 1/2 , 1/3 + class-specific rate matching
	CRC size	8	0	0
	Resulting ratio after static rate matching	0.5 to 4 (with no coding the rate matching ratio needs to be >1)		

## 12 History

<b>Document history</b>		
<b>Date</b>	<b>Version</b>	<b>Comment</b>
January 1999	0.0.0	Starting point based on UMTS YY.02 V1.2.0 (ETSI SMG2/UMTS-L23 60/99)
January 1999	0.0.1	version after TSG RAN WG2 #1 based on the agreed changes after review of Tdoc TSG RAN WG2 025/99.
March 1999	0.1.0	Same as version 0.0.1 with changes approved. Format has been updated according to 3GPP template.
April 1999	0.1.1	version after TSG RAN WG2 #2 based on agreed changes proposed by Tdoc TSG RAN WG2 151/99
April 1999	0.1.2	Re-issue (application of Tdoc TSG RAN WG2 187/99)
April 1999	0.2.0	version based on agreed changes proposed by Tdocs TSG RAN WG2 298/99 & 318/99.
April 1999	0.3.0	version after TSG RAN WG2 #3. Slight editorial changes. Document approved by TSG RAN WG3.
April 1999	2.0.0	Endorsed by TSG-RAN as TS 25.302 V2.0.0
May 1999	2.0.1	Endorsed by TSG-RAN as TS 25.302 V2.0.0
May 1999	2.1.0	Version edited after the drafting group on 25.302 during RAN WG2 #4. Missing agreed changes during drafting group are a section on the list of measurements needed from the physical .  Note that the other agreed changes during TSG RAN WG2 #4 are not incorporated and will be incorporated in the next version.
June 1999	2.2.0	version after with the following changes: <ul style="list-style-type: none"> <li>· Tdoc RAN2 (99)478 on CPCH</li> <li>· Incorporation of a new section on measurements based on last version of 25.331</li> <li>· Editorial alignment on the title of Annex A.</li> </ul> <p>Note that other changes in the TSG RAN WG2 #4 meeting were approved in version 2.1.0.</p>
June 1999	2.3.0	version after e-mail approval for presentation to RAN plenary for approval.  Note that although the description is stable the document is not yet fully complete.

June 1999	2.3.0	Endorsed by TSG-RAN
July 1999	2.4.0	Edited after WG2 meeting #5.
Rapporteur for TS 25.302 is :		
Pierre Lescuyer Nortel Networks Tel: +33 1 39 44 44 86 Fax: +33 1 39 44 50 02 email: <a href="mailto:lescuyer@nortelnetworks.com">lescuyer@nortelnetworks.com</a>		
This document is written in Microsoft Word version 7.0.		