

Busan, Korea, Mai 21st - Mai 25th 2001

Agenda Item: R4 CRs
Source: Siemens AG
Title: Correction of TTI for PCH (3.84 Mcps TDD Rel-4)
Document for: Approval

Introduction

In the current set of specifications the TTI for the paging channel is not consistently described between WG1 and WG2. This CR corrects the value given in WG2 (TS 25.302) in the technical Report TR25.944 to 20ms. The TTI of 20 ms allows furthermore a multiplexing with the PICH. In the figure 30 the TFCH is now also depicted to indicate, that the S-CCPCH carries the TFCH.

CR-Form-v4

CHANGE REQUEST

⌘ **TR25.944 CR 008** ⌘ ev **-** ⌘ Current version: **4.0.1** ⌘

For **HELP** on using this form, see bottom of this page or look at the pop-up text over the ⌘ symbols.

Proposed change affects: ⌘ (U)SIM ME/UE Radio Access Network Core Network

Title:	⌘ Correction of TTI for PCH (3.84 Mcps TDD, Rel-4)		
Source:	⌘ Siemens AG		
Work item code:	⌘	Date:	⌘ 15.05.2001
Category:	⌘ F	Release:	⌘ REL-4
	Use <u>one</u> of the following categories: F (correction) A (corresponds to a correction in an earlier release) B (addition of feature), C (functional modification of feature) D (editorial modification)		Use <u>one</u> of the following releases: 2 (GSM Phase 2) R96 (Release 1996) R97 (Release 1997) R98 (Release 1998) R99 (Release 1999) REL-4 (Release 4) REL-5 (Release 5)
	Detailed explanations of the above categories can be found in 3GPP TR 21.900 .		

Reason for change:	⌘ misalignment between WG1 (TR 25.944) and WG2 (TS 25.302) spec		
Summary of change:	⌘ TTI for PCH is changed from 10ms to 20ms		
Consequences if not approved:	⌘ misalignment remains between WG1 and WG2 spec		

Clauses affected:	⌘ 4.2.1.2		
Other specs affected:	⌘ <input type="checkbox"/> Other core specifications <input type="checkbox"/> Test specifications <input type="checkbox"/> O&M Specifications	⌘	
Other comments:	⌘		

How to create CRs using this form:

Comprehensive information and tips about how to create CRs can be found at: http://www.3gpp.org/3G_Specs/CRs.htm. Below is a brief summary:

- 1) Fill out the above form. The symbols above marked ⌘ contain pop-up help information about the field that they are closest to.
- 2) Obtain the latest version for the release of the specification to which the change is proposed. Use the MS Word "revision marks" feature (also known as "track changes") when making the changes. All 3GPP specifications can be downloaded from the 3GPP server under [ftp://ftp.3gpp.org/specs/](http://ftp.3gpp.org/specs/). For the latest version, look for the directory name with the latest date e.g. 2001-03 contains the specifications resulting from the March 2001 TSG meetings.
- 3) With "track changes" disabled, paste the entire CR form (use CTRL-A to select it) into the specification just in front of the clause containing the first piece of changed text. Delete those parts of the specification which are not relevant to the change request.

4.2.1.2 Example for PCH and FACH

Table 26: Parameters for PCH and FACH

Transport block size	PCH	$N_{PCH}=80$ or 240 bit
	FACH1	363 bit
	FACH2	171 bit
Transport block set size	PCH	$80 \cdot B_{PCH}$ or $240 \cdot B_{PCH}$ bit ($B_{PCH}=0,1$)
	FACH1	$363 \cdot B_{FACH1}$ bit ($B_{FACH1}=0,1$)
	FACH2	$171 \cdot B_{FACH2}$ bit ($B_{FACH2}=0,1,2$)
Coding	PCH, FACH2	CC, coding rate = 1/2
	FACH1	TC
TTI		40 20 ms
Midamble		512 chips
Codes and time slots		SF = $16 \times \underline{2-1} \times 1$ time slot
TFCI		16 bit
TPC		0 bit

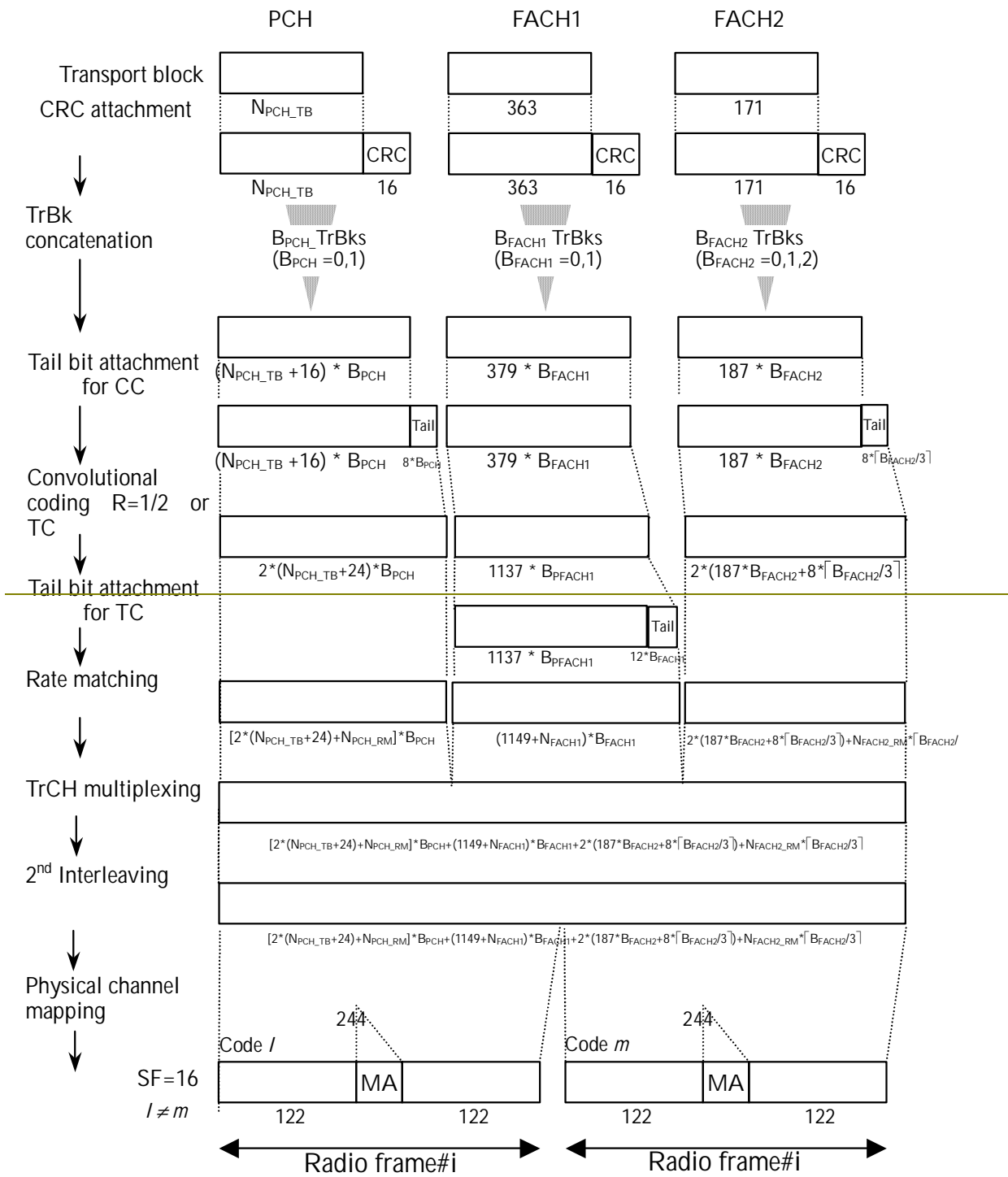

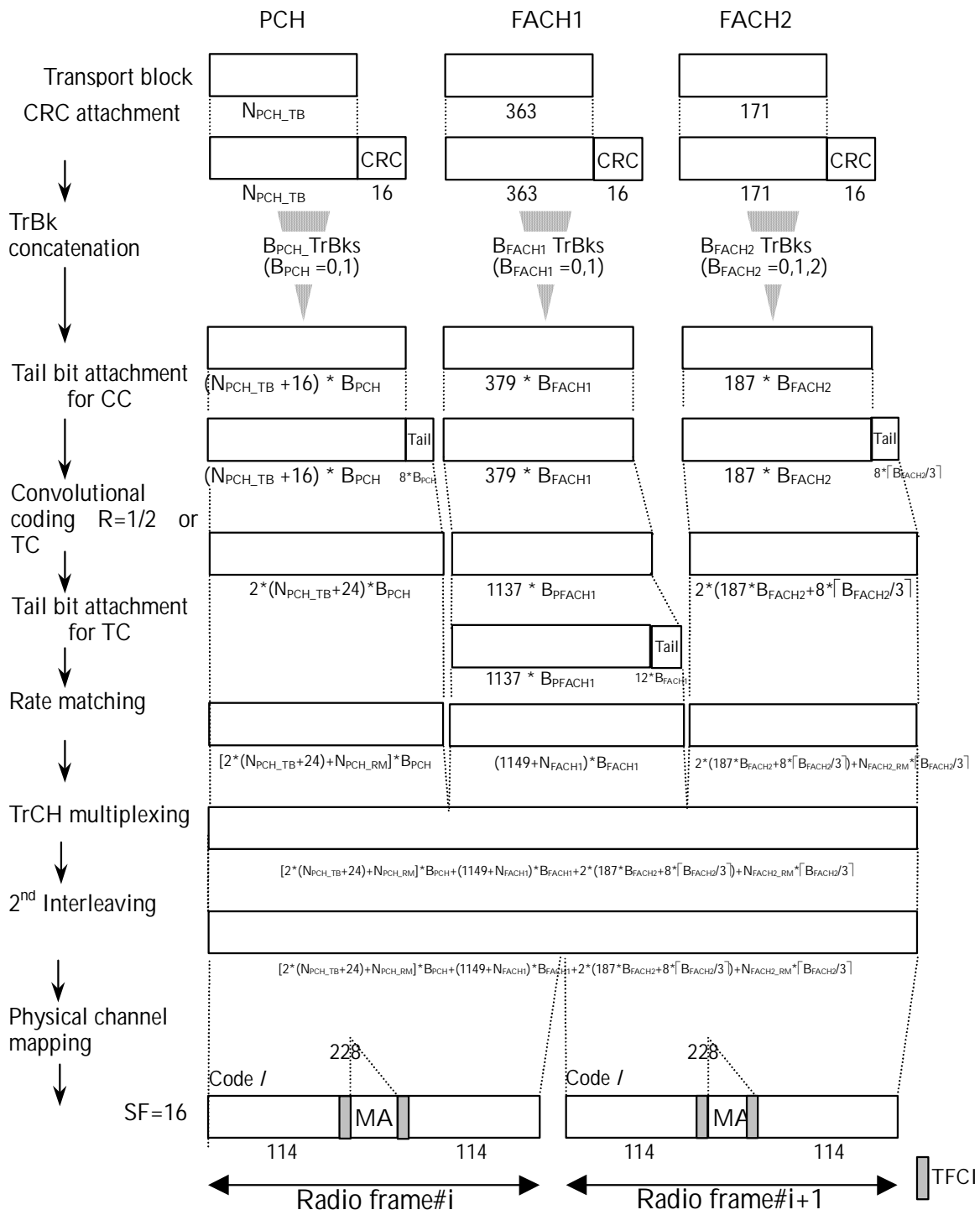

Figure 30: Channel coding and multiplexing example for PCH and FACH