

## CHANGE REQUEST

✎ 25.201 CR 06 ✎ rev 1 ✎ Current version: 3.1.0 ✎

For **HELP** on using this form, see bottom of this page or look at the pop-up text over the ✎ symbols.

Proposed change affects: ✎ (U)SIM  ME/UE  Radio Access Network  Core Network

<b>Title:</b>	✎ Inclusion of 1.28Mcps TDD in TS 25.201		
<b>Source:</b>	✎ CWTS/CATT, Siemens		
<b>Work item code:</b>	✎ LCRTDD	<b>Date:</b>	✎ 28.02.2001
<b>Category:</b>	✎ B	<b>Release:</b>	✎ REL-4
<i>Use <u>one</u> of the following categories:</i>		<i>Use <u>one</u> of the following releases:</i>	
F (essential correction)		2 (GSM Phase 2)	
A (corresponds to a correction in an earlier release)		R96 (Release 1996)	
B (Addition of feature),		R97 (Release 1997)	
C (Functional modification of feature)		R98 (Release 1998)	
D (Editorial modification)		R99 (Release 1999)	
Detailed explanations of the above categories can be found in 3GPP TR 21.900.		REL-4 (Release 4)	
		REL-5 (Release 5)	

<b>Reason for change:</b>	✎ Inclusion of 1.28 Mcps TDD in 25.201
<b>Summary of change:</b>	✎
<b>Consequences if not approved:</b>	✎

<b>Clauses affected:</b>	✎
<b>Other specs Affected:</b>	✎ <input checked="" type="checkbox"/> Other core specifications ✎ 25.221, 25.222, 25.223, 25.224, 25.225
	✎ <input type="checkbox"/> Test specifications
	✎ <input type="checkbox"/> O&M Specifications
<b>Other comments:</b>	✎

### How to create CRs using this form:

Comprehensive information and tips about how to create CRs can be found at: [http://www.3gpp.org/3G\\_Specs/CRs.htm](http://www.3gpp.org/3G_Specs/CRs.htm). Below is a brief summary:

- 1) Fill out the above form. The symbols above marked ✎ contain pop-up help information about the field that they are closest to.
- 2) Obtain the latest version for the release of the specification to which the change is proposed. Use the MS Word "revision marks" feature (also known as "track changes") when making the changes. All 3GPP specifications can be downloaded from the 3GPP server under <ftp://www.3gpp.org/specs/> For the latest version, look for the directory name with the latest date e.g. 2000-09 contains the specifications resulting from the September 2000 TSG meetings.

---

# 1 Scope

The present document describes a general description of the physical layer of the UTRA radio interface. The present document also describes the document structure of the 3GPP physical layer specifications, i.e. TS 25.200 series. The TS 25.200 series specifies the Uu point for the 3G mobile system, and defines the minimum level of specifications required for basic connections in terms of mutual connectivity and compatibility.

---

# 2 References

The following documents contain provisions which, through reference in this text, constitute provisions of the present document.

?? References are either specific (identified by date of publication, edition number, version number, etc.) or non-specific.

?? For a specific reference, subsequent revisions do not apply.

?? For a non-specific reference, the latest version applies.

- [1] 3G TS 25.211: "Physical channels and mapping of transport channels onto physical channels (FDD)".
- [2] 3G TS 25.212: "Multiplexing and channel coding (FDD)".
- [3] 3G TS 25.213: "Spreading and modulation (FDD)".
- [4] 3G TS 25.214: "Physical layer procedures (FDD)".
- [5] 3G TS 25.215: "Physical layer – Measurements (FDD)".
- [6] 3G TS 25.221: "Physical channels and mapping of transport channels onto physical channels (TDD)".
- [7] 3G TS 25.222: "Multiplexing and channel coding (TDD)".
- [8] 3G TS 25.223: "Spreading and modulation (TDD)".
- [9] 3G TS 25.224: "Physical layer procedures (TDD)".
- [10] 3G TS 25.225: "Physical layer – Measurements (TDD)".
- [11] 3G TR 25.833: "Physical layer items not for inclusion in Release '99".
- [12] 3G TR 25.944: "Channel coding and multiplexing examples".
- [13] 3G TS 25.301: "Radio Interface Protocol Architecture".
- [14] 3G TS 25.302: "Services provided by the physical layer".
- [15] 3G TS 25.101: "UE Radio transmission and reception (FDD)".
- [16] 3G TS 25.102: "UE Radio transmission and reception (TDD)".
- [17] 3G TS 25.104: "BTS Radio transmission and reception (FDD)".
- [18] 3G TS 25.105: "BTS Radio transmission and reception (TDD)".

---

## 3 Abbreviations

For the purposes of the present document, the following abbreviations apply:

ARQ	Automatic Repeat Request
BER	Bit Error Rate
CCTrCH	Coded Composite Transport Channel
CPCH	Common Packet Channel
DCA	Dynamic channel allocation
DCH	Dedicated Channel
DS-CDMA	Direct-Sequence Code Division Multiple Access
DSCH	Downlink Shared Channel
<a href="#">DwPCH</a>	<a href="#">Downlink Pilot Channel</a>
<a href="#">DwPTS</a>	<a href="#">Downlink Pilot Time Slot</a>
FAUSCH	Fast Uplink Signalling Channel
FDD	Frequency Division Duplex
FEC	Forward Error Correction
FER	Frame Error Rate
GSM	Global System for Mobile Communication
L1	Layer 1 (physical layer)
L2	Layer 2 (data link layer)
L3	Layer 3 (network layer)
LAC	Link Access Control
MAC	Medium Access Control
Mcps	Mega Chip Per Second
ODMA	Opportunity Driven Multiple Access
QPSK	Quaternary Phase Shift Keying
RACH	Random Access Channel
RF	Radio Frequency
RLC	Radio Link Control
RRC	Radio Resource Control
SAP	Service Access Point
SCCC	Serial Concatenated Convolutional Code
SCH	Synchronisation Channel
SIR	Signal-to-Interference Ratio
TDD	Time Division Duplex
TDMA	Time Division Multiple Access
TFCI	Transport-Format Combination Indicator
UE	User Equipment
UMTS	Universal Mobile Telecommunications System
<a href="#">UpPTS</a>	<a href="#">Uplink Pilot Time Slot</a>
<a href="#">UpPCH</a>	<a href="#">Uplink Pilot Channel</a>
UTRA	UMTS Terrestrial Radio Access
UTRAN	UMTS Terrestrial Radio Access Network
WCDMA	Wide-band Code Division Multiple Access

---

## 4 General description of Layer 1

### 4.1 Relation to other layers

#### 4.1.1 General Protocol Architecture

Radio interface which is prescribed by this specification means the Uu point between User Equipment (UE) and network. The radio interface is composed of Layers 1, 2 and 3. Layer 1 is based on WCDMA/[TD-SCDMA](#) technology and the TS 25.200 series describes the Layer-1 specification. Layers 2 and 3 of the radio interface are described in the TS 25.300 and 25.400 series, respectively.

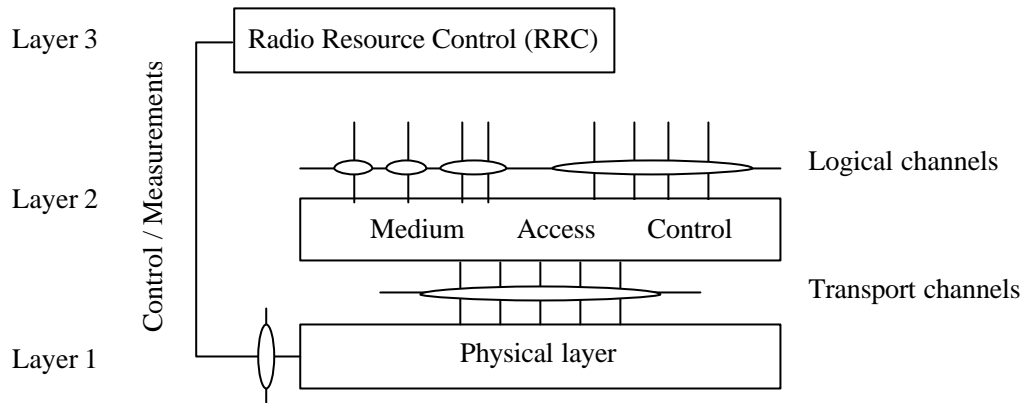

**Figure 1: Radio interface protocol architecture around the physical layer**

Figure 1 shows the UTRA radio interface protocol architecture around the physical layer (Layer 1). The physical layer interfaces the Medium Access Control (MAC) sub-layer of Layer 2 and the Radio Resource Control (RRC) Layer of Layer 3. The circles between different layer/sub-layers indicate Service Access Points (SAPs). The physical layer offers different Transport channels to MAC. A transport channel is characterized by how the information is transferred over the radio interface. MAC offers different Logical channels to the Radio Link Control (RLC) sub-layer of Layer 2. A logical channel is characterized by the type of information transferred. Physical channels are defined in the physical layer. There are two duplex modes: Frequency Division Duplex (FDD) and Time Division Duplex (TDD). In the FDD mode a physical channel is characterized by the code, frequency and in the uplink the relative phase (I/Q). In the TDD mode the physical channels is also characterized by the timeslot. The physical layer is controlled by RRC.

#### 4.1.2 Service provided to higher layers

The physical layer offers data transport services to higher layers. The access to these services is through the use of transport channels via the MAC sub-layer. The physical layer is expected to perform the following functions in order to provide the data transport service. See also TS 25.302:

- Macrodiversity distribution/combining and soft handover execution.
- Error detection on transport channels and indication to higher layers.
- FEC encoding/decoding of transport channels.
- Multiplexing of transport channels and demultiplexing of coded composite transport channels (CCTrCHs).
- Rate matching of coded transport channels to physical channels .
- Mapping of coded composite transport channels on physical channels.
- Power weighting and combining of physical channels.
- Modulation and spreading/demodulation and despreading of physical channels.
- Frequency and time (chip, bit, slot, frame) synchronisation.
- Radio characteristics measurements including FER, SIR, Interference Power, etc., and indication to higher layers.
- Inner - loop power control.
- RF processing. (Note: RF processing is defined in TS 25.100 series).
- [synchronization shift control](#)
- [beamforming](#)

When network elements (UEs and network) provide compatible service bearers (for example support a speech bearer) they should be assured of successful interworking. Moreover, different implementation options of the same (optional) feature would lead to incompatibility between UE and network. Therefore, this shall be avoided.

## 4.2 General description of Layer 1

### 4.2.1 Multiple Access

The access scheme is Direct-Sequence Code Division Multiple Access (DS-CDMA) with information [either](#) spread over approximately 5 MHz ([FDD and 3.84 Mcps TDD](#)) bandwidth, thus also often denoted as Wideband CDMA (WCDMA) due that nature [or 1.6MHz \(1.28Mcps TDD\), thus also often denoted as Narrowband CDMA.](#)

UTRA has two modes, FDD (Frequency Division Duplex) & TDD (Time Division Duplex), for operating with paired and unpaired bands respectively. The possibility to operate in either FDD or TDD mode allows for efficient utilisation of the available spectrum according to the frequency allocation in different regions. FDD and TDD modes are defined as follows:

**FDD:** A duplex method whereby uplink and downlink transmissions use two separated radio frequencies. In the FDD, each uplink and downlink uses the different frequency band. A pair of frequency bands which have specified separation shall be assigned for the system.

**TDD:** A duplex method whereby uplink and downlink transmissions are carried over same radio frequency by using synchronised time intervals. In the TDD, time slots in a physical channel are divided into transmission and reception part. Information on uplink and downlink are transmitted reciprocally.

[UTRA TDD has two options, the 3.84Mcps option and the 1.28Mcps option.](#) In UTRA TDD there is TDMA component in the multiple access in addition to DS-CDMA. Thus the multiple access has been also often denoted as TDMA/CDMA due added TDMA nature.

A 10 ms radio frame is divided into 15 slots (2560 chip/slot at the chip rate 3.84 Mcps). A physical channel is therefore defined as a code (or number of codes) and additionally in TDD mode the sequence of time slots completes the definition of a physical channel.

The information rate of the channel varies with the symbol rate being derived from the 3.84 Mcps chip rate and the spreading factor. Spreading factors are from 256 to 4 with FDD uplink, from 512 to 4 with FDD downlink, and from 16 to 1 for TDD uplink and downlink. Thus the respective modulation symbol rates vary from 960 k symbols/s to 15 k symbols/s (7.5 k symbols/s) for FDD uplink (downlink), and for TDD the momentary modulation symbol rates shall vary from 3.84 M symbols/s to 240 k symbols/s.

[For 1.28Mcps TDD option, a 10 ms radio frame is divided into two 5ms sub-frames. In each sub-frame, there are 7 normal time slots and 3 special time slots. A basic physical channel is therefore characterised by the frequency, code and time slot.](#)

[The information rate of the channel varies with the symbol rate being derived from the 1.28 Mcps chip rate and the spreading factor. Spreading factors is from 16 to 1 for both uplink and downlink. Thus the respective modulation symbol rates shall vary from 80.0K symbols/s to 1.28M symbols/s.](#)

### 4.2.2 Channel coding and interleaving

For the channel coding in UTRA three options are supported:

- Convolutional coding.
- Turbo coding.
- No coding.

Channel coding selection is indicated by higher layers. In order to randomise transmission errors, bit interleaving is performed further.

### 4.2.3 Modulation and spreading

The UTRA modulation scheme is QPSK ([8PSK is also used for 1.28Mcps TDD option](#)). Pulse shaping is specified in the TS 25.100 series.

With CDMA nature the spreading (& scrambling) process is closely associated with modulation. In UTRA different families of spreading codes are used to spread the signal:

- For separating channels from same source, channelisation codes derived with the code tree structure as given in TS 25.213 and 25.223 are used.
- For separating different cells the following solutions are supported.
  - FDD mode: Gold codes with 10 ms period (38400 chips at 3.84 Mcps) used, with the actual code itself length  $2^{18}-1$  chips, as defined in TS 25.213.
  - TDD mode: Scrambling codes with the length 16 used as defined in TS 25.223.
- For separating different UEs the following code families are defined.
  - FDD mode: Gold codes with 10 ms period, or alternatively S(2) codes 256 chip period.
  - TDD mode: codes with period of 16 chips and midamble sequences of different length depending on the environment.

#### 4.2.4 Physical layer procedures

There are several physical layer procedures involved with UTRA operation. Such procedures covered by physical layer description are:

- 1) The power control, with both inner loop and slow quality loop for FDD mode, and for [3.84Mcps TDD mode option](#) open loop in uplink and inner loop in downlink, [for 1.28Mcps TDD option, open loop in uplink and inner loop in both uplink and downlink](#).
- 2) Cell search operation.
- 3) [Uplink synchronization control with open and closed loop](#).
- 4) [Random access](#).
- ~~3) [ODMA specific procedures such as probing for TDD mode](#).~~

#### 4.2.5 Physical layer measurements

Radio characteristics including FER, SIR, Interference power, etc., are measured and reported to higher layers and network. Such measurements are:

- 1) Handover measurements for handover within UTRA. Specific features being determined in addition to the relative strength of the cell, for the FDD mode the timing relation between for cells for support of asynchronous soft handover.
- 2) The measurement procedures for preparation for handover to GSM900/GSM1800.
- 3) The measurement procedures for UE before random access process.
- 4) The measurement procedures for Dynamic Channel Allocation (DCA) of TDD mode.

#### 4.2.6 Relationship of the physical layer functions

The functionality of the layer 1 is split over several specifications each for FDD and TDD. The following figures, although not categorical, show as an introduction the relationship of layer 1 functions by specification in terms of users plane information flow.

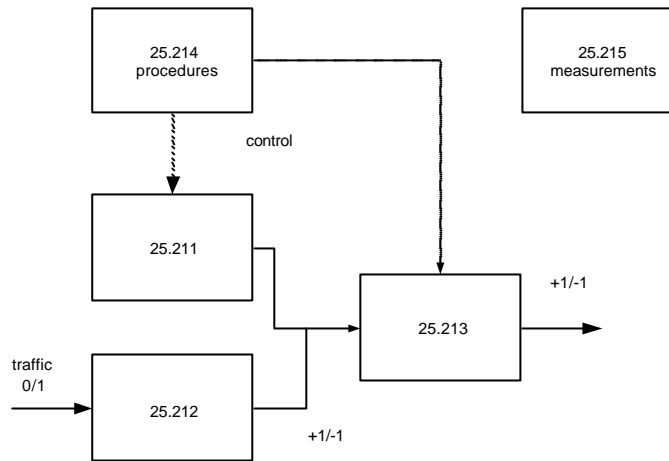

Figure 2 - FDD layer 1 functions relationships by specification

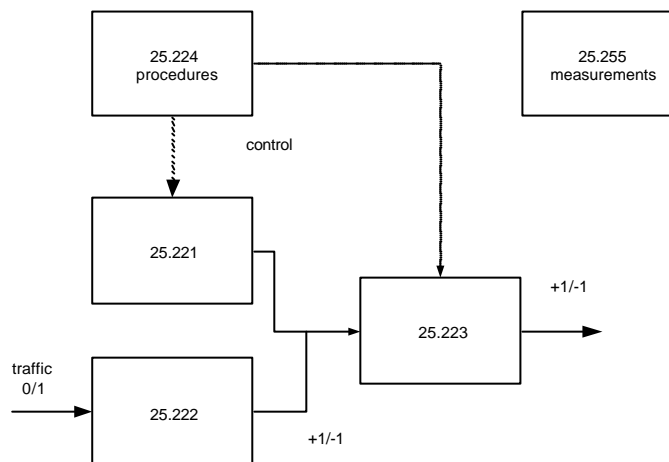

Figure 3 - TDD layer 1 functions relationships by specification

---

## 5 Document structure of physical layer specification

### 5.1 Overview

The physical layer specification consists of a general document (TS 25.201), five FDD mode documents (TS 25.211 through 25.215), five TDD mode documents (TS 25.221 through 25.225). In addition, there are two technical reports (TR 25.833 and 25.944).

### 5.2 TS 25.201: Physical layer – General description

The scope is to describe:

- the contents of the Layer 1 documents (TS 25.200 series);
- where to find information;
- a general description of Layer 1.

## 5.3 TS 25.211: Physical channels and mapping of transport channels onto physical channels (FDD)

The scope is to establish the characteristics of the Layer-1 transport channels and physical channels in the FDD mode, and to specify:

- the different transport channels that exist;
- which physical channels exist;
- what is the structure of each physical channel, slot format etc.;
- relative timing between different physical channels in the same link, and relative timing between uplink and downlink;
- mapping of transport channels onto the physical channels.

## 5.4 TS 25.212: Multiplexing and channel coding (FDD)

The scope is to describe multiplexing, channel coding and interleaving in the FDD mode, and to specify:

- coding and multiplexing of transport channels into CCTrCHs;
- channel coding alternatives;
- coding for Layer 1 control information, such as TFCI;
- the different interleavers;
- how is rate matching done;
- physical channel segmentation and mapping.

## 5.5 TS 25.213: Spreading and modulation (FDD)

The scope is to establish the characteristics of the spreading and modulation in the FDD mode, and to specify:

- the spreading (channelisation plus scrambling);
- generation of channelisation and scrambling codes;
- generation of RACH and CPCH preamble codes;
- generation of SCH synchronisation codes;
- modulation.

RF channel arrangements and Pulse shaping are specified in TS 25.101 for UE and in TS 25.104 for Node-B.

## 5.6 TS 25.214: Physical layer procedures (FDD)

The scope is to establish the characteristics of the physical layer procedures in the FDD mode, and to specify:

- cell search procedures;
- power control procedures;
- random access procedure.



## 5.7 TS 25.215: Physical layer – Measurements (FDD)

The scope is to establish the characteristics of the physical layer measurements in the FDD mode, and to specify:

- the measurements that Layer 1 is to perform;
- reporting of measurements to higher layers and network;
- handover measurements, idle-mode measurements etc.

## 5.8 TS 25.221: Physical channels and mapping of transport channels onto physical channels (TDD)

The scope is to establish the characteristics of the Layer-1 transport channels and physical channels in the TDD mode, and to specify:

- transport channels;
- physical channels, structure and contents;
- mapping of transport channels onto the physical channels.

## 5.9 TS 25.222: Multiplexing and channel coding (TDD)

The scope is to describe multiplexing, channel coding and interleaving in the TDD mode, and to specify:

- channel coding and multiplexing of transport channels into CCTrCHs;
- channel coding alternatives;
- coding for Layer 1 control information, such as TFCI;
- interleaving;
- rate matching;
- physical channel segmentation and mapping.

## 5.10 TS 25.223: Spreading and modulation (TDD)

The scope is to establish the characteristics of the spreading and modulation in the TDD mode, and to specify:

- data modulation;
- spreading;
- generation of synchronisation codes.

RF channel arrangements and Pulse shaping are specified in TS 25.102 for UE and in TS 25.105 for Node-B.

## 5.11 TS 25.224: Physical layer procedures (TDD)

The scope is to establish the characteristics of the physical layer procedures in the TDD mode, and to specify:

- cell synchronisation;
- timing advance;
- power control procedures;
- idle mode tasks.

## 5.12 TS 25.225: Physical layer – Measurements (TDD)

The scope is to establish the characteristics of the physical layer measurements in the TDD mode, and to specify:

- the measurements that Layer 1 is to perform;
- reporting of measurements to higher layers and network;
- handover measurements, idle-mode measurements etc.

## 5.13 TR 25.833: Physical layer items not for inclusion in Release '99

The scope is to collect materials on UTRA physical layer items not included in the Release '99 specification documents, such as DSCH control channel, FAUSCH, Hybrid ARQ, 4-state SCCC turbo coding and ODMA.

## 5.14 TR 25.944: Channel coding and multiplexing examples

The scope is to describe examples of channel coding and multiplexing for transport channels of various types and cases .