

Agenda Item :
Source : Samsung, GBT, LGIC, Lucent. Nokia
Title : CD/CA-ICH for dual mode CPCH (rev. 3)
Document for : Discussion and approval

For dual mode CPCH, namely, the UE channel selection method and the channel assignment method, the collision detection (CD) and channel assignment (CA) indication channel (CD/CA-ICH) is proposed in this CR instead of CD-ICH. Based on this CR, when the CA is not active, only the CD indicator is transmitted by CD/CA-ICH. On the other hand, in case the CA is active, both of the CD indicator and CA indicator are transmitted by CD/CA-ICH. The hardware structure of CD/CA-ICH is same between two methods. Only the contents of the message are different between two schemes.

<h2 style="margin: 0;">CHANGE REQUEST</h2>		<small>Please see embedded help file at the bottom of this page for instructions on how to fill in this form correctly.</small>
25.211	CR	031r3
		Current Version: 3.1.1
<small>GSM (AA.BB) or 3G (AA.BBB) specification number ↑</small>		<small>↑ CR number as allocated by MCC support team</small>
For submission to: TSG-RAN #7 <small>list expected approval meeting # here ↑</small>	for approval <input checked="" type="checkbox"/> for information <input type="checkbox"/>	strategic <input type="checkbox"/> non-strategic <input type="checkbox"/> <small>(for SMG use only)</small>

Form: CR cover sheet, version 2 for 3GPP and SMG The latest version of this form is available from: ftp://ftp.3gpp.org/Information/CR-Form-v2.doc

Proposed change affects: (U)SIM ME UTRAN / Radio Core Network
(at least one should be marked with an X)

Source: Samsung, GBT, LGIC, Lucent, Nokia **Date:** 28-Feb-2000

Subject: CD/CA-ICH for dual mode CPCH

Work item: _____

Category:	F Correction <input type="checkbox"/> A Corresponds to a correction in an earlier release <input type="checkbox"/> B Addition of feature <input checked="" type="checkbox"/> C Functional modification of feature <input type="checkbox"/> D Editorial modification <input type="checkbox"/>	Release:	Phase 2 <input type="checkbox"/> Release 96 <input type="checkbox"/> Release 97 <input type="checkbox"/> Release 98 <input type="checkbox"/> Release 99 <input checked="" type="checkbox"/> Release 00 <input type="checkbox"/>
------------------	--	-----------------	--

(only one category shall be marked with an X)

Reason for change: For dual mode CPCH, the CD/CA-ICH is used instead of CD-ICH. In UE channel selection method, only the CD indicator is transmitted by CD/CA-ICH. On the other hand, both of the CD and CA indicators are transmitted by CD/CA-ICH for channel assignment method.

Clauses affected: 3, 5.3.3.6 ~ 5.3.3.9 of TS25.211

Other specs affected:	Other 3G core specifications <input type="checkbox"/> Other GSM core specifications <input type="checkbox"/> MS test specifications <input type="checkbox"/> BSS test specifications <input type="checkbox"/> O&M specifications <input type="checkbox"/>	→ List of CRs: → List of CRs: → List of CRs: → List of CRs: → List of CRs:	
------------------------------	---	--	--

Other comments: _____

<----- double-click here for help and instructions on how to create a CR.

1 Scope

The present document describes the characteristics of the Layer 1 transport channels and physical channels in the FDD mode of UTRA. The main objectives of the document are to be a part of the full description of the UTRA Layer 1, and to serve as a basis for the drafting of the actual technical specification (TS).

2 References

The following documents contain provisions which, through reference in this text, constitute provisions of the present document.

- References are either specific (identified by date of publication, edition number, version number, etc.) or non-specific.
- For a specific reference, subsequent revisions do not apply.
- For a non-specific reference, the latest version applies.

- [1] 3G TS 25.201: "Physical layer - general description"
- [2] 3G TS 25.211: "Physical channels and mapping of transport channels onto physical channels (FDD)"
- [3] 3G TS 25.212: "Multiplexing and channel coding (FDD)"
- [4] 3G TS 25.213: "Spreading and modulation (FDD)"
- [5] 3G TS 25.214: "Physical layer procedures (FDD)"
- [6] 3G TS 25.221: "Transport channels and physical channels (TDD)"
- [7] 3G TS 25.222: "Multiplexing and channel coding (TDD)"
- [8] 3G TS 25.223: "Spreading and modulation (TDD)"
- [9] 3G TS 25.224: "Physical layer procedures (TDD)"
- [10] 3G TS 25.231: "Measurements"
- [11] 3G TS 25.301: "Radio Interface Protocol Architecture"
- [12] 3G TS 25.302: "Services Provided by the Physical Layer"
- [13] 3G TS 25.401: "UTRAN Overall Description"

3 Abbreviations

For the purposes of the present document, the following abbreviations apply:

AI	Acquisition Indicator
AICH	Acquisition Indicator Channel
AP	Access Preamble
<u>AP-AICH</u>	<u>Access Preamble Acquisition Indicator Channel</u>
<u>API</u>	<u>Access Preamble Indicator</u>
BCH	Broadcast Channel
<u>CA</u>	<u>Channel Assignment</u>
<u>CAI</u>	<u>Channel Assignment Indicator</u>
CCPCH	Common Control Physical Channel
CCTrCH	Coded Composite Transport Channel
CD	Collision Detection

<u>CD/CA-ICH</u>	<u>Collision Detection/Channel Assignment Indicator Channel</u>
<u>CDI</u>	<u>Collision Detection Indicator</u>
CPCH	Common Packet Channel
CPICH	Common Pilot Channel
DCH	Dedicated Channel
DPCCH	Dedicated Physical Control Channel
DPCH	Dedicated Physical Channel
DPDCH	Dedicated Physical Data Channel
DSCH	Downlink Shared Channel
DTX	Discontinuous Transmission
FACH	Forward Access Channel
FBI	Feedback Information
MUI	Mobile User Identifier
PCH	Paging Channel
P-CCPCH	Primary Common Control Physical Channel
PCPCH	Physical Common Packet Channel
PDSCH	Physical Downlink Shared Channel
PI	Page Indicator
PICH	Page Indicator Channel
PRACH	Physical Random Access Channel
PSC	Primary Synchronisation Code
RACH	Random Access Channel
RNC	Radio Network Controller
S-CCPCH	Secondary Common Control Physical Channel
SCH	Synchronisation Channel
SF	Spreading Factor
SFN	System Frame Number
SSC	Secondary Synchronisation Code
STTD	Space Time Transmit Diversity
TFCI	Transport Format Combination Indicator
TSTD	Time Switched Transmit Diversity
TPC	Transmit Power Control
UE	User Equipment
UTRAN	UMTS Terrestrial Radio Access Network

A DSCH may be mapped to multiple parallel PDSCHs as well, as negotiated at higher layer prior to starting data transmission. In such a case the parallel PDSCHs shall be operated with frame synchronization between each other.

Table 19: PDSCH fields

Slot format #i	Channel Bit Rate (kbps)	Channel Symbol Rate (ksps)	SF	Bits/ Frame	Bits/ Slot	Ndata
0	30	15	256	300	20	20
1	60	30	128	600	40	40
2	120	60	64	1200	80	80
3	240	120	32	2400	160	160
4	480	240	16	4800	320	320
5	960	480	8	9600	640	640
6	1920	960	4	19200	1280	1280

When transmit diversity is employed for the PDSCH, STTD encoding is used on the data bits as described in section 5.3.1.1.1.

5.3.3.6 Acquisition Indicator Channel (AICH)

The Acquisition Indicator channel (AICH) is a physical channel used to carry Acquisition Indicators (AI). Acquisition Indicator AI_s corresponds to signature s on the PRACH_s or PCPCH. Note that for PCPCH, the AICH either corresponds to an access preamble or a CD preamble. The AICH corresponding to the access preamble is an AP AICH and the AICH corresponding to the CD preamble is a CD AICH. The AP AICH and CD AICH use different channelization codes, see further [4], Section 4.3.3.2.

Figure 19 illustrates the structure of the AICH. The AICH consists of a repeated sequence of 15 consecutive access slots (AS), each of length 40 bit intervals. Each access slot consists of two parts, an Acquisition-Indicator (AI) part consisting of 32 real-valued symbols a_0, \dots, a_{31} and an unused part consisting of 8 real-valued symbols a_{32}, \dots, a_{39} .

The phase reference for the AICH is the Primary CPICH.

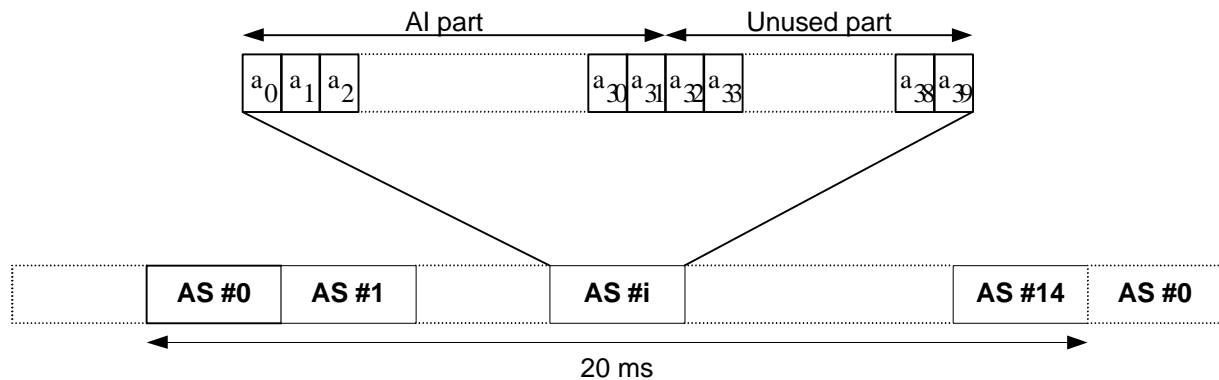

Figure 19: Structure of Acquisition Indicator Channel (AICH)

The real-valued symbols a_0, a_1, \dots, a_{31} in Figure 19 are given by

$$a_j = \sum_{s=0}^{15} AI_s \times b_{s,j}$$

where AI_s , taking the values +1, -1, and 0, is the acquisition indicator corresponding to signature s and the sequence $b_{s,0}, \dots, b_{s,31}$ is given by Table 20.

The real-valued symbols $a_{32}, a_{33}, \dots, a_{39}$ in Figure 19 are undefined.

5.3.3.8 CPCH Collision Detection/Channel Assignment Indicator Channel (CD/CA-ICH)

The Collision Detection Channel Assignment Indicator channel (CD/CA-ICH) is a physical channel used to carry CD Indicator (CDI) only if the Channel Assignment message CA is not active, or CD Indicator/CA Indicator (CDI/CAI) at the same time if the Channel Assignment message CA is active. The structure of CD/CA-ICH is shown in Figure 21. CD/CA-ICH and AP-AICH may use the same or different channelisation codes.

The CD/CA-ICH has a part of duration of 4096chips where the CDI/CAI is transmitted, followed by a part of duration 1024chips with no transmission.

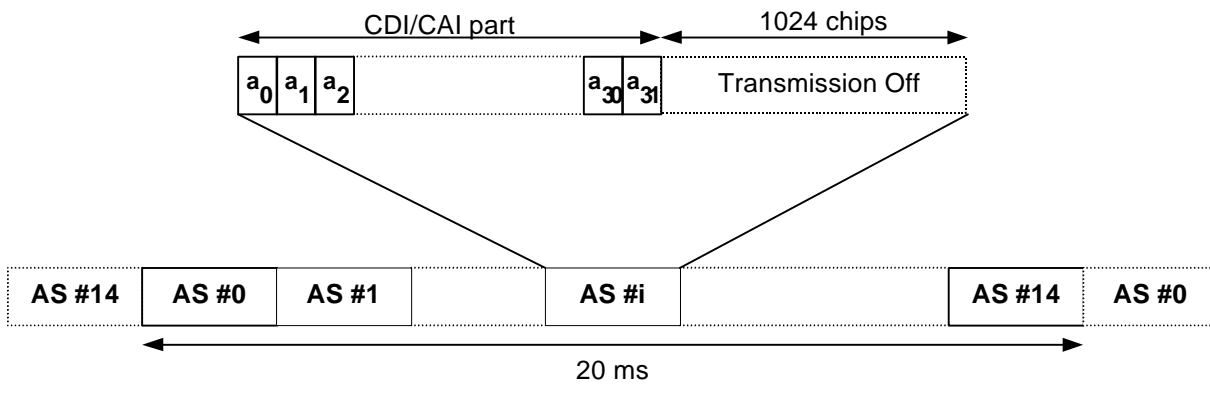

Figure 21: Structure of CD/CA Indicator Channel (CD/CA-ICH)

In case STTD-based open-loop transmit diversity is applied to AP-AICH, STTD encoding according to section 5.3.1.1.1 is applied to each sequence $b_{s,0}, b_{s,1}, \dots, b_{s,31}$, separately before the sequences are combined into CD/CA-ICH symbols a_0, \dots, a_{31} .

In case CA is not active, the real-valued symbols a_0, a_1, \dots, a_{31} in Figure 21 are given by

$$a_j = \sum_{s=0}^{15} CDI_s \times b_{s,j}$$

where CDI_s , taking the values +1, and 0, is the CD indicator corresponding to CD preamble signature s transmitted by UE and the sequence $b_{s,0}, \dots, b_{s,31}$ is given by in Table 20.

In case CA is active, the real-valued symbols a_0, a_1, \dots, a_{31} in Figure 21 are given by

$$a_j = \sum_{i=0}^{15} CDI_i \times b_{s_i,j} + \sum_{k=0}^{15} CAI_k \times b_{s_k,j}$$

where the subscript s_i, s_k depend on the indexes i, k according to Table 21, respectively, and indicate the signature number s in Table 20. The sequence $b_{s,0}, \dots, b_{s,31}$ is given in Table 20. ~~where the subscript s in $b_{s,i}$ is the signature number in table 20 and associated with the index i as given in table 21.~~ CDI_i , taking the values +1/0 or -1/0, is the CD indicator corresponding to the CD preamble i transmitted by the UE, and CAI_k , taking the values +1/0 or -1/0, is the CA indicator corresponding to the assigned channel index k as given in table 21. ~~The sequence $b_{s,0}, \dots, b_{s,31}$ is given by Table 20.~~

Table 21. Generation of CDI_i/CAI_{ik}

<u>UE transmitted CD Preamble</u> i	<u>CDI_i</u>	<u>signature</u> s_i	<u>Channel Assignment Index</u> k	<u>CAI_k</u>	<u>signature</u> s_k
0	+1/0	1	0	+1/0	0

<u>1</u>	<u>-1/0</u>		<u>1</u>	<u>-1/0</u>	
<u>2</u>	<u>+1/0</u>	<u>3</u>	<u>2</u>	<u>+1/0</u>	<u>8</u>
<u>3</u>	<u>-1/0</u>		<u>3</u>	<u>-1/0</u>	
<u>4</u>	<u>+1/0</u>	<u>5</u>	<u>4</u>	<u>+1/0</u>	<u>4</u>
<u>5</u>	<u>-1/0</u>		<u>5</u>	<u>-1/0</u>	
<u>6</u>	<u>+1/0</u>	<u>7</u>	<u>6</u>	<u>+1/0</u>	<u>12</u>
<u>7</u>	<u>-1/0</u>		<u>7</u>	<u>-1/0</u>	
<u>8</u>	<u>+1/0</u>	<u>9</u>	<u>8</u>	<u>+1/0</u>	<u>2</u>
<u>9</u>	<u>-1/0</u>		<u>9</u>	<u>-1/0</u>	
<u>10</u>	<u>+1/0</u>	<u>11</u>	<u>10</u>	<u>+1/0</u>	<u>6</u>
<u>11</u>	<u>-1/0</u>		<u>11</u>	<u>-1/0</u>	
<u>12</u>	<u>+1/0</u>	<u>13</u>	<u>12</u>	<u>+1/0</u>	<u>10</u>
<u>13</u>	<u>-1/0</u>		<u>13</u>	<u>-1/0</u>	
<u>14</u>	<u>+1/0</u>	<u>15</u>	<u>14</u>	<u>+1/0</u>	<u>14</u>
<u>15</u>	<u>-1/0</u>		<u>15</u>	<u>-1/0</u>	

5.3.3.79 Page Indicator Channel (PICH)

The Page Indicator Channel (PICH) is a fixed rate (SF=256) physical channel used to carry the Page Indicators (PI). The PICH is always associated with an S-CCPCH to which a PCH transport channel is mapped.

Figure 20-22 illustrates the frame structure of the PICH. One PICH frame of length 10 ms consists of 300 bits (b_0, b_1, \dots, b_{299}). Of these, 288 bits (b_0, b_1, \dots, b_{287}) are used to carry Page Indicators. The remaining 12 bits ($b_{288}, b_{289}, \dots, b_{299}$) are undefined.

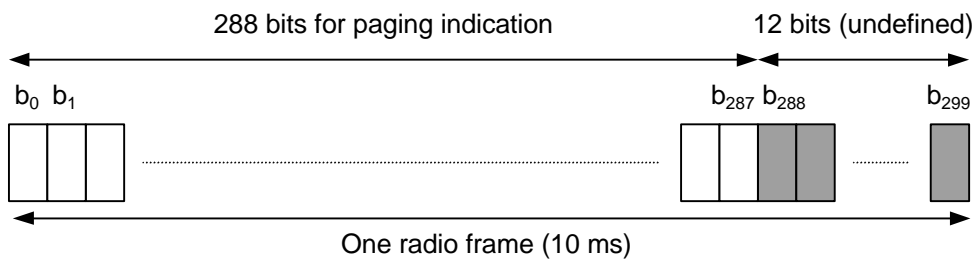

Figure 220: Structure of Page Indicator Channel (PICH)

N Page Indicators $\{PI_0, \dots, PI_{N-1}\}$ are transmitted in each PICH frame, where $N=18, 36, 72, \text{ or } 144$.

The PI calculated by higher layers for use for a certain UE, is mapped to the paging indicator PI_p , where p is computed as a function of the PI computed by higher layers, the SFN of the P-CCPCH radio frame during which the start of the PICH radio frame occurs, and the number of paging indicators per frame (N):