

TSG-RAN Working Group1 meeting #7
30 August – 3 September 1999
Hanover, Germany

TSGR1#7(99)b51

Agenda Item:

Source: Motorola, NTT DoCoMo, Samsung

Title: Text proposal for section 7 in 25.214_(rev.2)

Document for: Decision

Introduction

In WG1#6, AH14 reached consensus as following;

“Transmission Stop and Resumption Control” and “DPCCH gating in Control Only Substate” shall be merged.

Section 7 in 25.214 “Transmission Stop and Resumption Control” shall be replaced by R1-99988 “Text proposal for DPCCH gating in Control Only Substate” with some modifications.

It is reached consensus that R1-99922 “Revised Text for the Rapid Initial Synchronization of the DCH for Packet Data” shall be added to section 7 in 25.214.

This document includes text proposals according to above consensus.

7 — Transmission stop and resumption control

<Editor's note: This control scheme is under discussion in ad hoc 14.>

1.1.7.1 — General

On dedicated physical channels, when no higher layer data exist to transmit, the DPDCH is empty and is not transmitted. In order to save channel capacity, under some conditions the transmission of the DPCCH can also be stopped. Similarly, conditions are also defined for how the transmission of DPCCH/DPDCH is resumed.

<Editor's note: From Volume 3 figure 3.2.6 16 it seems that the transmission stop scheme is only applicable when the other link do not transmit a DPDCH, while this is not explained in the text. Clarification is needed on this point.>

1.2.7.2 — Transmission stop control

1.2.1.7.2.1 — Network control procedure

The necessity of downlink DPCCH/DPDCH transmission is judged in each radio frame. When the DPDCH is stopped, i.e. there is no data to transmit on the DPDCH, the network continues to transmit the DPCCH until both Figure 1999Fkp f radio frames have passed after the DPDCH transmission was stopped,

— and Fcrs b radio frames are detected consecutively with no correct CRC in uplink,

when the DPCCH transmission is stopped as well.

The parameters Fkp f [= 2] and Fcrs b [= 2] are set by higher layer procedures.

1.2.2.7.2.2 — UE control procedure

The necessity of uplink DPCCH/DPDCH transmission is judged in each radio frame. When the DPDCH is stopped, i.e. there is no data to transmit on the DPDCH, the UE continues to transmit the DPCCH until both Figure 1999Fkp b radio frames have passed after the DPDCH transmission was stopped,

— and the downlink is detected to be out of synchronisation,

when the DPCCH transmission is stopped as well.

The parameter Fkp b [= 2] is set by higher layer procedures.

1.2.3.7.2.3 — Illustration of network and UE procedures

Figure 6 illustrates the scheme for the case where there exist a DPCCH/DPDCH in downlink and a DPCCH in uplink, and transmission of the downlink DPDCH is stopped.

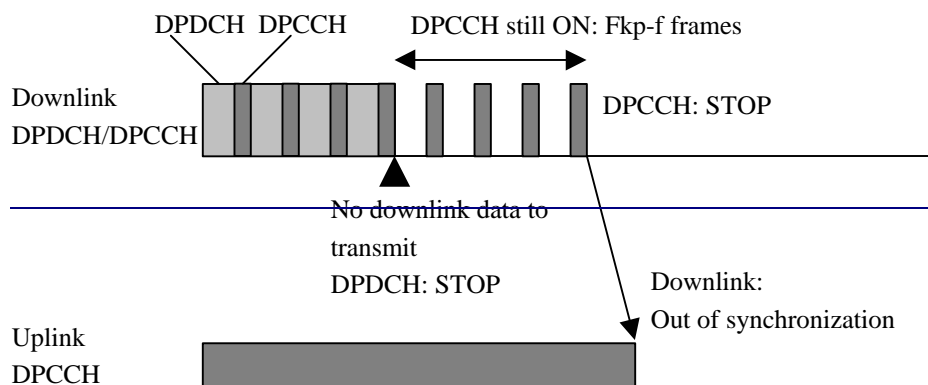

Figure 6: Transmission stop control when downlink DPDCH is stopped

Figure 7 illustrates the scheme for the case where there exist a DPCCH/DPDCH in uplink and a DPCCH in downlink, and transmission of the uplink DPDCH is stopped.

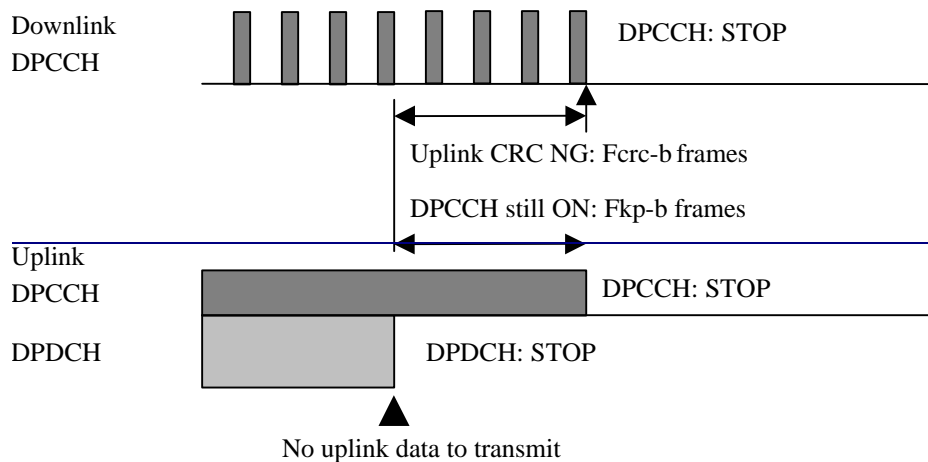

Figure 7: Transmission stop control when uplink DPDCH is stopped

1.3.7.3 Transmission resumption control

1.3.1.7.3.1 Network control procedure

Suspended downlink DPCCH/DPDCH transmission is resumed without higher layer signals if data to be transmitted on the DPDCH is generated. When resuming DPDCH transmission, the network transmits dummy frames prior to radio frames with real data.

The number of dummy frames to transmit is F_{tr} . If the number of frames after pausing transmission of both DPCCH and DPDCH is less than F_{gap} , where chip and frame synchronisation is expected to be kept, the dummy frames consist of only DPCCH (pilot and TPC) transmitted in the last Str slots of each dummy frame. If the number of frames after pausing transmission is more than F_{gap} , the dummy frames consist of only DPCCH, and the TPC commands are set to a predetermined pattern, for example indicating transmission power increase. The network selects an initial transmission power to be used when starting to send the dummy frames, and increases its transmission power by P_{up} dB in each Sup slots until receiving the DPCCH in the uplink, but the maximum transmission power is limited to P_{max} dBm. After sending the dummy frames, closed loop power control is applied to the downlink transmission as described in subclause 5.2.3.

Also, suspended downlink DPCCH transmission is resumed when synchronisation is established with the corresponding uplink dedicated physical channel that was previously in out of synchronisation. When DPCCH transmission is resumed the network selects an initial transmission power to be used, and applies closed loop power control to the downlink transmission as described in subclause 5.2.3.

The parameters F_{tr} [$=2$], Sup [$=4$], P_{up} [$=1$], P_{max} , F_{gap} [$=2$], Str [$=4$] are set by higher layer procedures. The values of these parameters may be set differently between network and UE.

← Editor's note: The parameter P_{add} was removed, since it is anyway up to the network to set the initial power as it wishes. →

1.3.2.7.3.2 UE control procedure

Suspended uplink DPCCH/DPDCH transmission is resumed if data to be transmitted on the DPDCH is generated. When resuming DPDCH transmission, the UE transmits dummy frames prior to radio frames with real data.

The number of dummy frames to transmit is F_{tr} . The dummy frames consist of only DPCCH (pilot and TPC) transmitted in the last Str slots of each dummy frame. The TPC commands are set to a predetermined pattern, for example indicating transmission power increase.

Using an open loop transmit power estimate similar to the one described in subclause 5.1.1, the UE derives an initial transmission power to be used when starting to send the dummy frames, and increases its transmission power by P_{up} dB in each Sup slots until receiving the DPCCH in the downlink, but the maximum transmission power is limited to P_{max} dBm. After sending the dummy frames, closed loop power control is applied to the uplink transmission as described in subclause 5.1.2.

Also, suspended uplink DPCCH transmission is resumed when synchronisation is established with the corresponding downlink dedicated physical channel that was previously in out of synchronisation. When DPCCH transmission is resumed the UE selects an initial transmission power to be used based on an open loop transmit power estimate similar to the one described in subclause 5.1.1, and applies closed loop power control to the uplink transmission as described in subclause 5.1.2.

The parameters $F_{tr} [=2]$, $S_{up} [=4]$, $P_{up} [=1]$, P_{max} , $F_{gap} [=2]$, $S_{tr} [=4]$ are set by higher layer procedures. The values of these parameters may be set differently between network and UE.

1.3.3.7.3.3 Illustration of network and UE procedures

Figure 8 illustrates the scheme for the case where transmission of downlink DPDCH is resumed.

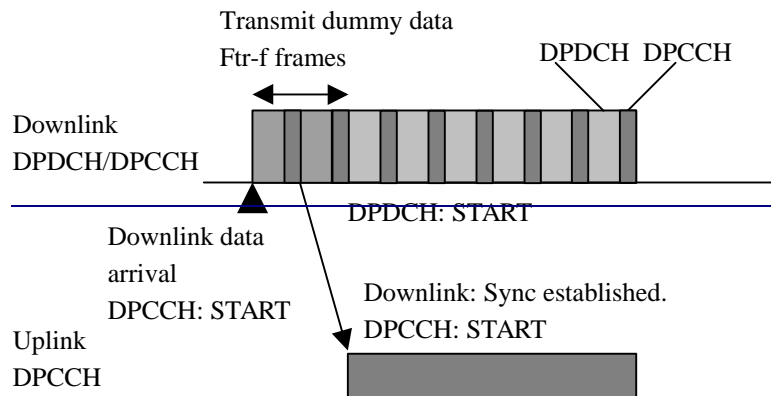

Figure 8: Transmission resumption of downlink DPDCH

Figure 9 illustrates the scheme for the case where transmission of uplink DPDCH is resumed.

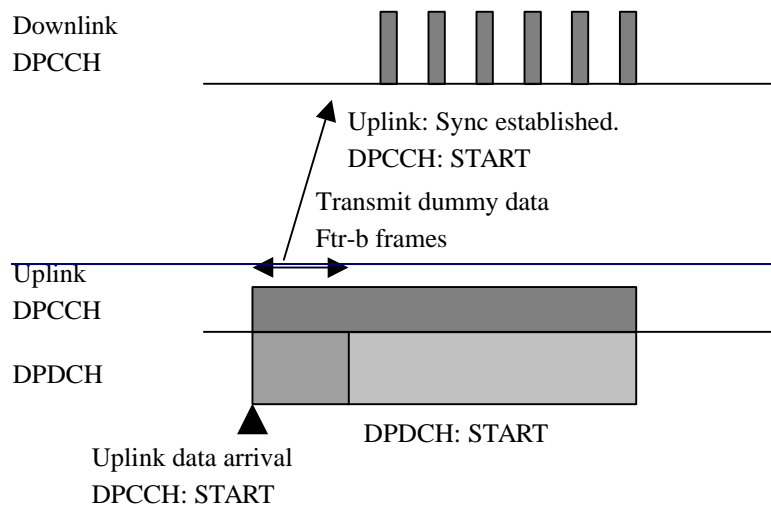

Figure 9: Transmission resumption of uplink DPDCH

7. Procedures in Packet Data Transfer

7.1 Gated transmission in Control Only Substate

7.1.1 General

The gated transmission of DPCCH in Control Only Substates (COS) may be initiated by the UTRAN to reduce the transmission rate of Pilot, TPC, TFCI or FBI.

7.1.2 DPCCH channel with gated transmission mode

The downlink and uplink DPCCH can be transmitted with the gated transmission mode enabled or disabled, as described in Figure 6.

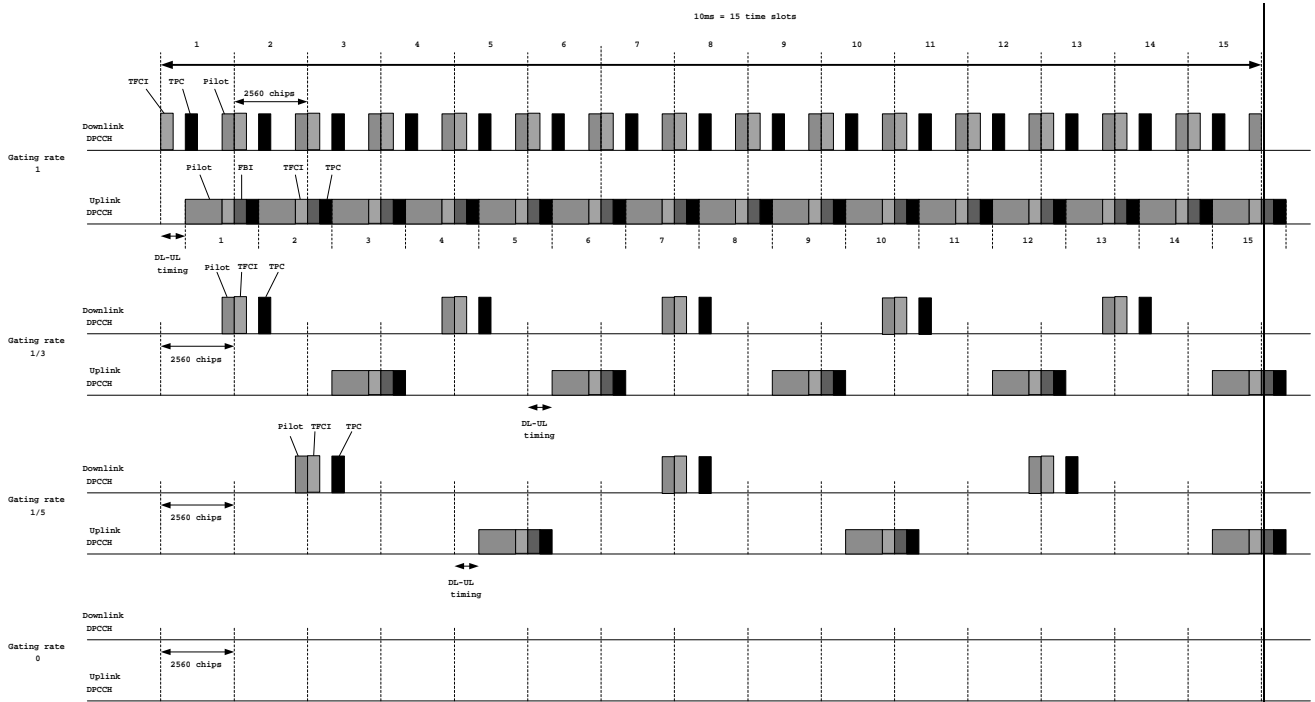

Figure 6. Downlink and uplink DPCCH transmission timing

When the gated transmission mode is disabled (i.e. the gating rate =1), the UTRAN and UE shall transmit the DPCCH in every time slot. When the gated transmission mode is enabled, the UTRAN and UE shall transmit the DPCCH only in the time slots that are gated on, as specified in Figure 6. The relative timings of the downlink and uplink DPCCH transmission when the gated transmission mode is enabled and disabled are depicted in Figure 6.

Gating Rate	Downlink DPCCH allocations (time slot numbers 1-15)	
	Pilot	TFCI, TPC
1	1, 2, 3, 4, 5, 6, 7, 8, 9, 10, 11, 12, 13, 14, 15	1, 2, 3, 4, 5, 6, 7, 8, 9, 10, 11, 12, 13, 14, 15
1/3	1, 4, 7, 10, 13	2, 5, 8, 11, 14
1/5	2, 7, 12	3, 8, 13
0	-	-

Table 5. Downlink DPCCH allocations during gated transmission mode enabled

Gating Rate	Uplink DPCCH allocations (time slot numbers 1-15)	
	Pilot	TFCI, FBI, TPC
1	1, 2, 3, 4, 5, 6, 7, 8, 9, 10, 11, 12, 13, 14, 15	1, 2, 3, 4, 5, 6, 7, 8, 9, 10, 11, 12, 13, 14, 15
1/3	3, 6, 9, 12, 15	3, 6, 9, 12, 15
1/5	5, 10, 15	5, 10, 15
0	-	-

Table 6. Uplink DPCCH allocations during gated transmission mode enabled

When transmitting only on the DPCCH, the UTRAN and UE may periodically gate off certain time slots of DPCCH at a rate specified by the gating rate which may be continuous(=1 rate), 1/3 rate, 1/5, or 0 rate. The downlink DPCCH allocations are given in Table 5 and the uplink DPCCH allocations are given in Table 6.

7.1.3 DPCCH gating during DPDCH transmission

Gating patterns for the downlink DPCCH with gating rate of 1, 1/3, 1/5, and 0 are given in Table 3. Gating patterns for the uplink DPCCH with gating rate of 1, 1/3, 1/5, and 0 are given in Table 4. Downlink DPCCH gating during DPDCH transmission is depicted in Figure 7. Uplink DPCCH gating during DPDCH transmission is depicted in Figure 8. When there is transmission on the DPDCH, the DPCCH shall be gated on (i.e. shall have a gating rate=1) for the duration of the active DPDCH frame, as given in Table 3 and 4. However, downlink TPC shall continue gate off with gating rate during downlink DPDCH transmission. Uplink TPC and FBI shall continue gate off with gating rate during uplink DPDCH transmission.

Gating Rate	Downlink DPCCH allocations (time slot numbers 1-15)	
	Pilot, TFCI	TPC
1	1, 2, 3, 4, 5, 6, 7, 8, 9, 10, 11, 12, 13, 14, 15	1, 2, 3, 4, 5, 6, 7, 8, 9, 10, 11, 12, 13, 14, 15
1/3	1, 2, 3, 4, 5, 6, 7, 8, 9, 10, 11, 12, 13, 14, 15	2, 5, 8, 11, 14
1/5	1, 2, 3, 4, 5, 6, 7, 8, 9, 10, 11, 12, 13, 14, 15	3, 8, 13
0	1, 2, 3, 4, 5, 6, 7, 8, 9, 10, 11, 12, 13, 14, 15	1, 2, 3, 4, 5, 6, 7, 8, 9, 10, 11, 12, 13, 14, 15

Table7. Downlink DPCCH allocations during DPDCH transmission

Gating Rate	Uplink DPCCH allocations (time slot numbers 1-15)	
	Pilot, TFCI	FBI, TPC
1	1, 2, 3, 4, 5, 6, 7, 8, 9, 10, 11, 12, 13, 14, 15	1, 2, 3, 4, 5, 6, 7, 8, 9, 10, 11, 12, 13, 14, 15
1/3	1, 2, 3, 4, 5, 6, 7, 8, 9, 10, 11, 12, 13, 14, 15	3, 6, 9, 12, 15
1/5	1, 2, 3, 4, 5, 6, 7, 8, 9, 10, 11, 12, 13, 14, 15	5, 10, 15
0	1, 2, 3, 4, 5, 6, 7, 8, 9, 10, 11, 12, 13, 14, 15	1, 2, 3, 4, 5, 6, 7, 8, 9, 10, 11, 12, 13, 14, 15

Table8. Uplink DPCCH allocations during DPDCH transmission

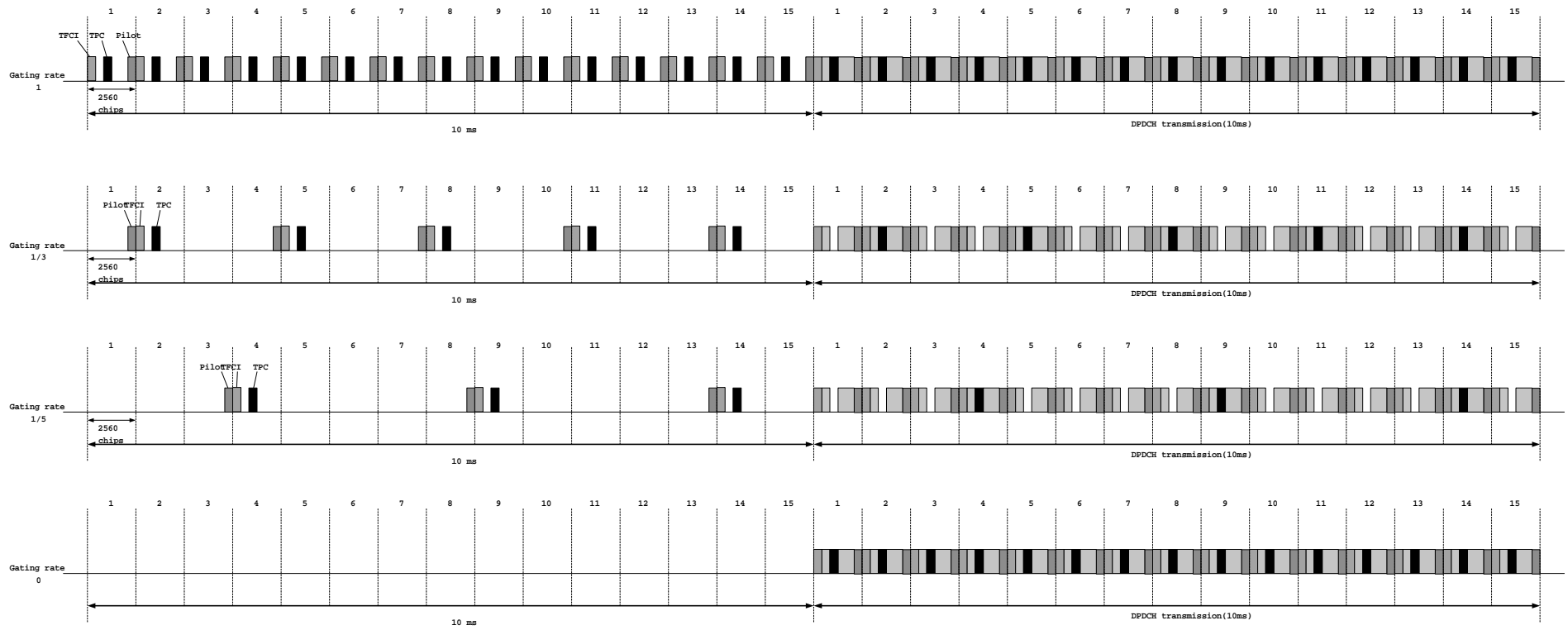
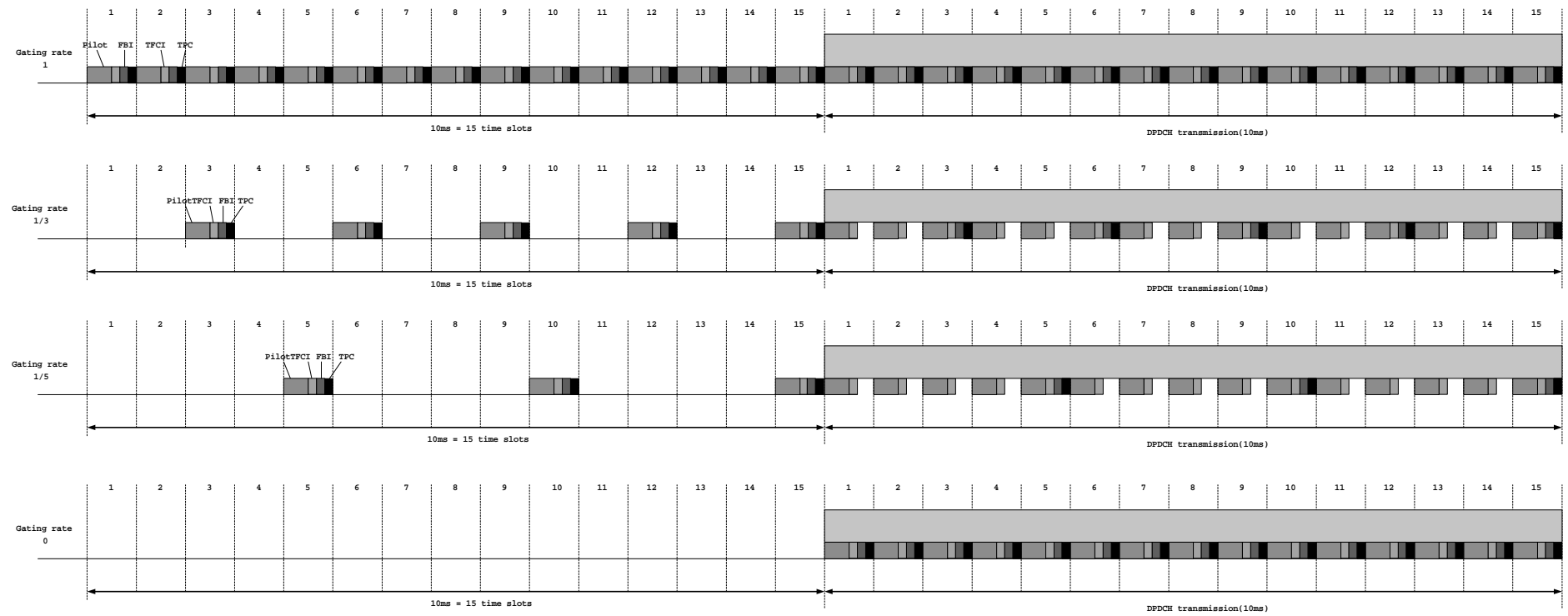

Figure 7. Downlink DPCCH gating during DPDCH transmission



[Figure 8. Uplink DPCCH gating during DPDCH transmission](#)

7.2 Rapid Initialization of DCH for Packet Data Transfer

A rapid initialization procedure for establishing a DCH is defined to support bursting packet data transfer. The rapid initialization may be invoked for downlink packet data transfer on the DSCH or uplink packet data transfer on the DCH. The procedure may also be invoked to resume a recently discontinued DCH connection.

7.2.1 Rapid Initialization of DCH for Packet Data Transfer using DSCH

The synchronization of the DSCH/DCH pair may be expedited so that data transmission using DSCH can commence in slightly over 10 ms following the FACH burst assigning the TFCI using DCH. Figure 9 shows the timing diagram of RACH/FACH to DCH/DCH+DSCH state transition. The parameter T_A specifies the RACH/FACH response time. The parameters T_B , T_C and T_D are referenced relative to the FACH frame. T_B specifies the time period when the downlink DPCCCH is started. The parameter T_C specifies the period at which the UE will start the uplink DPCCCH. Finally, T_D specifies the period that the DCH will be stable and the first frame of data may arrive. The parameters T_B , T_C , and T_D have the following relationship:

$$\begin{aligned} T_B &< T_C \ll T_D \\ T_D &= T_B + N_{slots} * 0.666 \end{aligned}$$

where N_{slots} is a positive integer.

In order to initialise fast uplink power control loop, searcher and channel estimator at the Node B, the UE will adhere to the following:

- The transmission of uplink DPCCCH will start at N_{slots} slots (1 to 15 slots) prior to the scheduled downlink packet data transmission using DSCH.
- The DPCCCH will be transmitted with an additional negative power offset P_{offset} from the computed open loop estimate.
- The initial power control step size for transmitting the DPCCCH will be set at P_{step} (typically: 2dB).
- The UE will revert back to the normal power control (PC) step size upon the receipt of the first down power control command during the uplink DPCCCH transmission phase.
- The step size always goes back to its nominal setting in the beginning of DSCH transmission

The parameters T_B , T_C , T_D , N_{slots} , P_{offset} and P_{step} may be negotiated with each individual UE or broadcast by the system so that the transition from RACH/FACH to DCH/DCH+DSCH sub-state is optimised.

<Editor's note: This procedure should be harmonized with the agreed power control procedure in ad-hoc-9>

7.2.2 Rapid Initialization of DCH for Uplink Packet Data Transfer

The synchronization of the DCH may also be expedited for the transfer of uplink packet data.. Figure 10 shows the same parameters T_B , T_C , and T_D applied to an uplink packet data transfer. The UE, upon detecting data in its queue, transmits a RACH with measurement report. After the UTRAN assigns the DCH via the FACH message, the downlink DPCCCH is started after a time period T_B . The UE then begins transmission of the uplink DPCCCH for reasons as outlined in section 7.3.4 at time period T_C . T_C is measured relative to the FACH transmit timing. Finally, the UE begins transmitting the data on the DPDCCH after the period. The procedure for starting the uplink DPCCCH transmission will be similar to Section 7.3.4.1

7.2.3 Resumption of DCH for Downlink or Uplink Packet Data Transfer

The synchronization of the DCH technique may be used to resume a DCH/DCH+DSCH connection that has been dropped for a short period.. This is applicable for packet data transfer using DSCH or uplink DPDCCH or bi-directional data transfer using DSCH/Uplink DPDCCH. Figure 11 shows the case where the DCH has been discontinued based on an inactivity timer T_E . The UTRAN, upon detecting data in the queue, may resume the DCH operation provided the period T_E has not elapsed. Typically T_E is set to 1000msec.

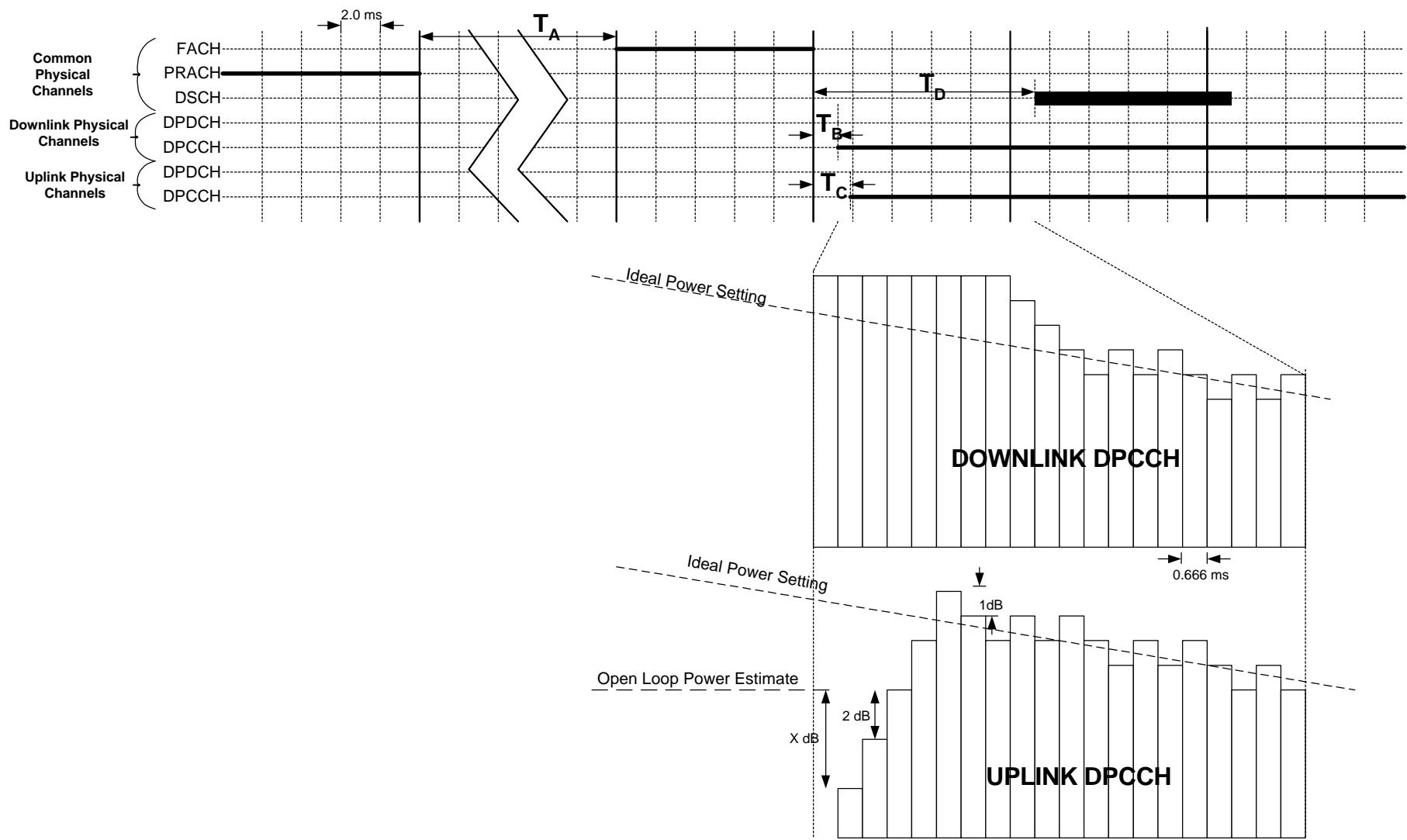

Figure 9 Rapid Initialization of DCH for packet data transfer over the DSCH.

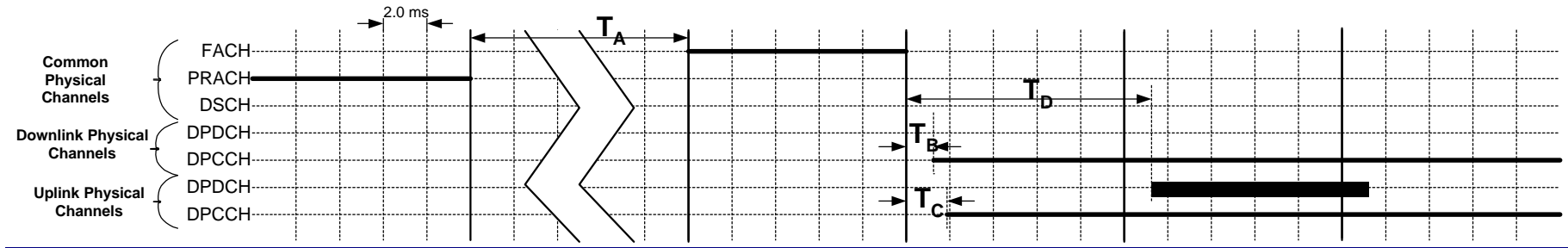

Figure 10 Rapid initialization of the DCH for transfer of uplink packet data.

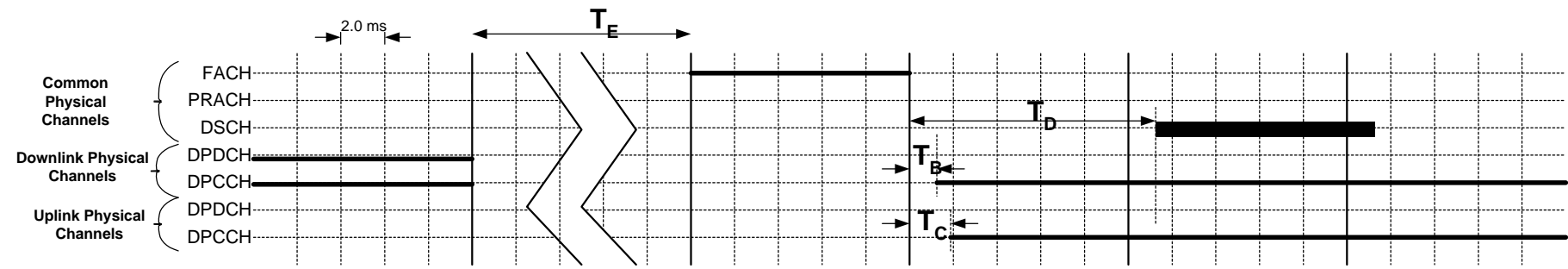

Figure 11 Resumption of the DCH for transmission of downlink packet data.