

TSG-RAN Working Group 1 (Radio) Meeting #5
Cheju, South Korea, June 1-4th, 1999

Agenda Item:

Source: CWTS WG1

Title: C1.21 Physical channels and mapping of transport channels onto physical channels (TD-SCDMA)

Document for: Information

TS C1.21 V1.1.0 (1999-05)

Technical Specification

**China Wireless Telecommunication Standard (CWTS);
Working Group 1 (WG1);
Physical channels and mapping of transport channels
onto physical channels (TD-SCDMA)**

CWTS

Content

CONTENT	2
1 SCOPE	3
2 REFERENCES	3
3 DEFINITIONS AND ABBREVIATIONS	3
4 TRANSPORT CHANNELS	4
4.1 TRANSPORT CHANNELS.....	4
4.1.1 <i>Dedicated transport channels</i>	5
4.1.2 <i>Common transport channels</i>	5
5 PHYSICAL CHANNELS	6
5.1 FRAME STRUCTURE.....	7
5.1.1 <i>General description</i>	7
5.1.2 <i>Special time slot for synchronization</i>	8
5.1.2.1 Downlink Pilot Time Slot (DwPTS)	8
5.1.2.2 Uplink Pilot Time Slot (UpPTS)	8
5.1.2.3 Guard Period (GP).....	9
5.2 DEDICATED PHYSICAL CHANNEL (DPCH).....	9
5.2.1 <i>Spreading codes</i>	9
5.2.1.1 Multicode transmission with fixed spreading	9
5.2.1.2 Single code transmission with variable spreading.....	9
5.2.2 <i>Burst Types</i>	9
5.2.2.1 Transmission of L1 Control Signals.....	11
5.2.2.2 Burst Structure when using DTX	12
5.2.2.3 L1 Control Signals	12
5.2.3 <i>Training sequences for spread bursts</i>	12
5.2.3.1 Example Midamble Code Set for Burst Type 1 and Type 2	13
5.2.3.2 Midamble Transmit Power	13
5.3 COMMON CONTROL PHYSICAL CHANNELS (CCPCH)	13
5.3.1 <i>Downlink common control physical channel</i>	14
5.3.1.1 Spreading codes	14
5.3.1.2 Burst Types	14
5.3.1.3 Training sequences for spread bursts.....	14
5.3.2 <i>The physical random access channel (PRACH)</i>	14
5.3.2.1 Spreading codes	14
5.3.2.2 Burst Types	14
5.3.2.3 Training sequences for access bursts.....	15
5.4 THE PHYSICAL SYNCHRONIZATION CHANNEL (PSCH)	15
6 MAPPING OF TRANSPORT CHANNELS TO PHYSICAL CHANNELS	15
6.1 DEDICATED TRANSPORT CHANNELS	16
6.2 COMMON TRANSPORT CHANNELS	16
6.2.1 <i>The Broadcast Channel (BCH)</i>	16
6.2.2 <i>The Paging Channel (PCH)</i>	16
6.2.3 <i>The Forward Access Channel (FACH)</i>	16
6.2.4 <i>The Random Access Channel (RACH)</i>	16
6.2.5 <i>The Synchronization Channel (SCH)</i>	17
6.3 MULTIFRAME STRUCTURE.....	17
HISTORY	17

1 Scope

2 References

- [1] B. Steiner, P. Jung: Uplink channel estimation in synchronous CDMA mobile radio systems with joint detection. The fourth International Symposium on Personal, Indoor and Mobile Radio Communications (PIMRC'93), Yokohama, Japan, September 8-11, 1993.
- [2] 3GPP TS S1.21 V2.0.0 (1999-04), "Physical channels and mapping of Transport channels
- [3] CWTS WG1 1999/xxx, "Method and Principle of Uplink Synchronization Used in

3 Definitions and abbreviations

<Editor's note: This section covers TDD relevant abbreviations only. >

BCH	Broadcast Channel
CCPCH	Common Control Physical Channel
CDMA	Code Division Multiple Access
DL	Downlink
DPCH	Dedicated Physical Channel
DRX	Discontinued Receive
DTX	Discontinued Transmit
DwPTS	Downlink Pilot Time Slot
FACH	Forward Access Channel
FDD	Frequency Division Duplex
FEC	Forward Error Correction
GP	Guard Period
GSM	Global System for Mobile Communication
GP	Guard Period
NRT	Non-Real Time
ODCH	ODMA Dedicated Transport Channel
ODMA	Opportunity Driven Multiple Access
ORACH	ODMA Random Access Channel
PCH	Paging Channel
PDU	Protocol Data Unit
PRACH	Physical Random Access Channel
PSCH	Physical Synchronization Channel
RACH	Random Access Channel
RLC	Radio Link Control
RT	Real Time
RU	Resource Unit
SACCH	Slow Associated Control Channel
SCH	Synchronization Channel
SDCCH	Stand-alone Dedicated Control Channel
SS	Synchronisation Shift
TCH	Traffic Channel

TDD	Time Division Duplex
TDMA	Time Division Multiple Access
TD-SCDMA	Time Division Synchronous CDMA

UL	Uplink
UpPTS	Uplink Pilot Time Slot

4 Transport channels

4.1 Transport channels

The chapter describes transport channels that are required for data transfer. Transport channels are the services offered by layer 1 to the higher layers. A general classification of transport channels is two groups:

- common channels (where there is a need for in-band identification of the UEs when particular UEs are addressed)
- dedicated channels (where the UEs identified by the physical channel, i.e. code , time slot and frequency)

4.1.1 Dedicated transport channels

The Dedicated Channel (DCH) is an uplink or downlink transport channel that is used to carry user or control information between the network and a UE.

Two types of dedicated transport channels have been identified:

1. Dedicated Channel (DCH) characterized by:
 - existence in uplink or downlink,
 - possibility to use beamforming,
 - possibility to use uplink synchronization (uplink only),
 - possibility to change rate fast (each 5ms),
 - closed loop power control (uplink only),
 - inherent addressing of UEs.

[Editors Note: The 3rd bullet point is added by WTS WG1.]

2. ODMA Dedicated Transport Channel (ODCH) characterized by:
 - possibility to change rate fast (each 5ms),
 - closed loop power control,
 - closed loop timing advance control,
 - temporary addressing of UEs.

[Editors Note: ODMA in TD-SCDMA is under study.]

4.1.2 Common transport channels

Common transport channels are:

1. Broadcast Channel (BCH) characterized by:
 - existence in downlink only,
 - low fixed bit rate,
 - requirement to be broadcast in the entire coverage area of the cell.

The Broadcast Channel (BCH) is a downlink transport channel that is used to broadcast system- and cell-specific information.

2. Paging Channel (PCH) characterised by:
 - existence in downlink only,
 - possibility for sleep mode procedures,
 - requirement to be broadcast in the entire coverage area of the cell.

The Paging Channel (PCH) is a downlink transport channel that is used to carry control information to a UE when the system does not know the location cell of the UE.

3. Forward Access Channel(s) (FACH) characterized by:
 - existence in downlink only,
 - possibility to use beamforming,
 - possibility to use power control,
 - possibility to change rate fast (each 5ms),
 - requirement for in-band identification of UEs.

The Forward Access Channel (FACH) is a downlink transport channel that is used to carry control information to a UE when the system knows the location cell of the UE. The FACH may also carry short user packets.

4. Random Access Channel(s) (RACH) characterized by:

- existence in uplink only,
- possibility to use beamforming,
- limited data field. The exact number of allowed bits is FFS,
- collision risk,
- possibility to use open loop and closed loop uplink synchronization,
- open loop and closed loop power control,
- requirement for in-band identification of the UEs.

[Editors Note: The 5th and 6th bullet point is added by WTS WG1.]

The Random Access Channel (RACH) is a reverse link transport channel that is used to carry control information from UE. The RACH may also carry short user packets.

5. ODMA Random Access Channel (ORACH) characterized by:

- existence in relay links,
- collision risk,
- open loop power control,
- no timing advance control,
- requirement for in-band identification of the UEs.

[Editors Note: ORACH in TD-SCDMA is under study.]

6. Synchronization Channel (SCH) characterized by:

- existence in downlink and uplink,
- possibility to use beamforming (uplink only),
- low fixed bit rate,
- requirement to be broadcast in the entire coverage area of the cell (downlink only).

[Editors Note: The 2nd bullet point is added by WTS WG1.]

5 Physical channels

All physical channels take four-layer structure of superframes, radio frames, subframes and time slots. Depending on the resource allocation, the configuration of subframes or time slots becomes different. All physical channels need guard symbols in every time slot. The time slots are used in the sense of a TDMA component to separate different user signals in the time and the code domain. The physical channel signal format is presented in Figure 1. The basic physical channel is defined as the association of one code, one time slot and one frequency.

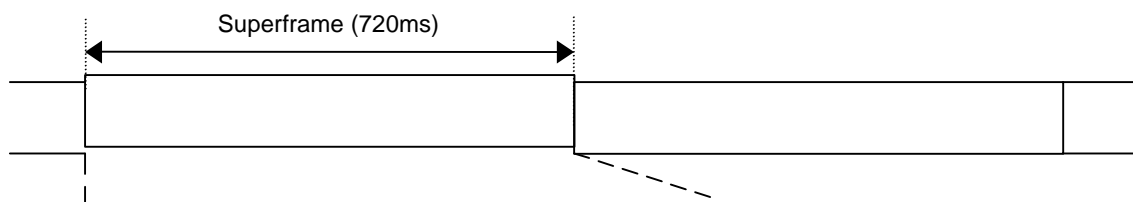

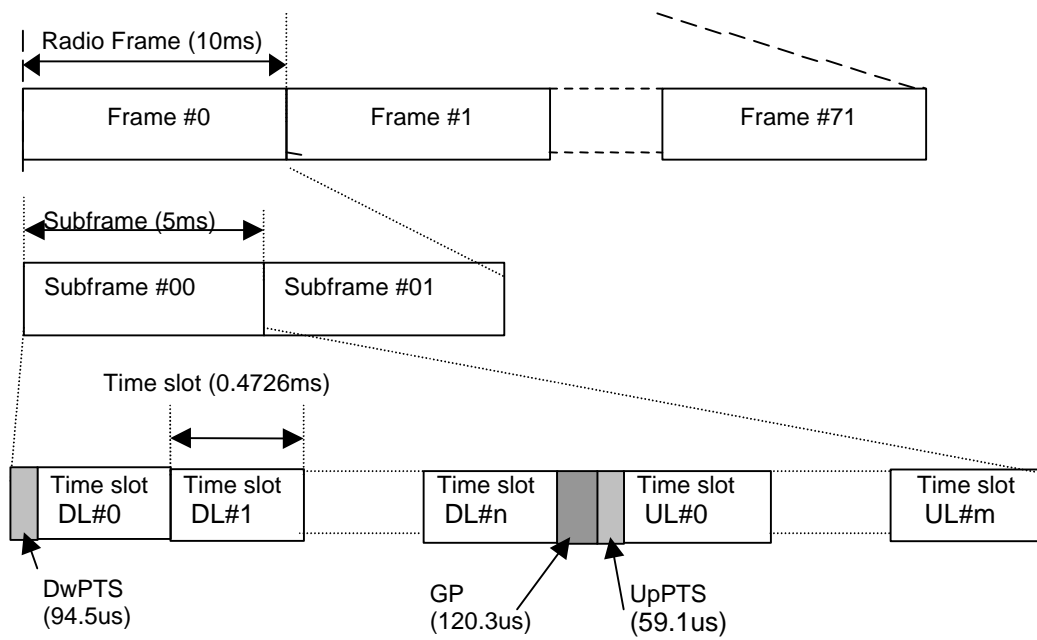

where $n + m + 2 = 10$

Figure 1. Physical channel signal format

5.1 Frame structure

5.1.1 Genereal description

The radio frame has a duration of 10 ms and is subdivided into 2 subframes of 5ms each, and each subframe is then subdivided into 10 main time slots (TS) of 472.6 μ s duration each and 3 special time slots: DwPTS (downlink pilot), GP (guard period) and UpPTS (uplink pilot). A time slot corresponds to 640 chips. The physical contents of the time slots are the bursts of corresponding length as described in section 5.2.2.

Among the 10 main time slots, for the uplink and the downlink are separated by single switching point, all the main time slots (at least the first main time slot) before the single switching point are allocated as downlink, and all the main time slots (at least the last main time slot) behind the single switching point are allocated as uplink (Figure 2). With such flexibility, the TDD mode can be adapted to different environments and deployment scenarios.

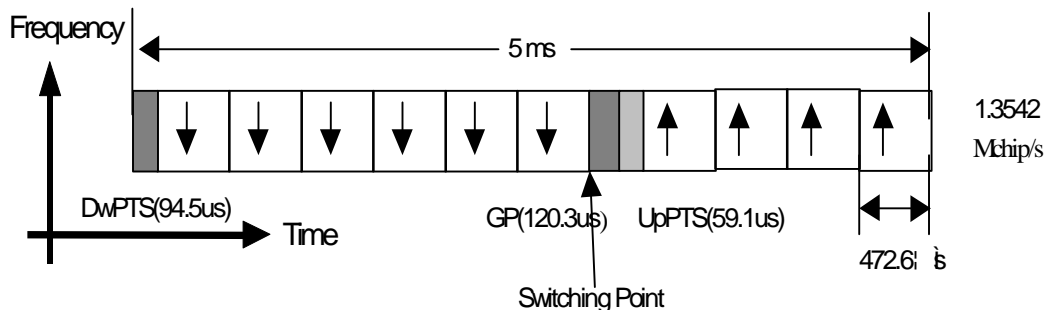
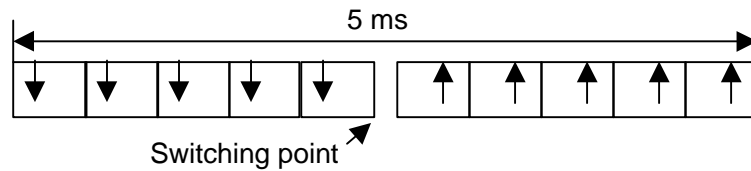
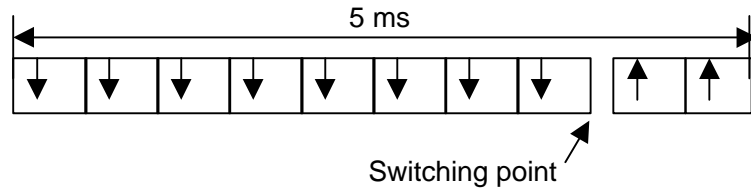

Figure 2. The TDD subframe structure

Examples for symmetric and asymmetric UL/DL allocations are given in Figure 3.



Symmetric DL/UL allocation



Asymmetric DL/UL allocation

Figure 3. TDD subframe structure examples

5.1.2 Special time slot for synchronization

5.1.2.1 Downlink Pilot Time Slot (DwPTS)

The DwPTS(SYNC) in each subframe is designed for both downlink pilot and SCH. The Node B would transmit it omnidirectionally or sectorially at the full power level without beamforming. This time slot is composed of 64 chips of SYNC and 64 chips of guard period as shown in Figure 4. The contents in the SYNC is a set of Gold code as defined in Table 1. The Gold code set is designed to distinguish nearby cells for the purpose of easier cell measurement. The set of code could be repeated in the cellular network.

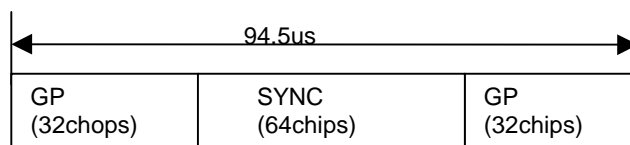

Figure 4. Burst structure of DwPTS

Table 1. The Gold code sequences of SYNC for downlink pilot

No.	Code sequences
0	
1	
2	
3	
4	
5	
6	
7	

5.1.2.2 Uplink Pilot Time Slot (UpPTS)

The UpPTS in each subframe is designed for both uplink pilot and SCH. When a UE is in the status of air-registration and random access, it would transmit UpPTS followed by RACH. The time slot is composed of 48chips of SYNC1 and 32chips of GP as shown in Figure 5. The contents in the SYNC1 is a set of Gold code as defined in Table 2. The Gold code set is designed to distinguish different UEs in access procedures.

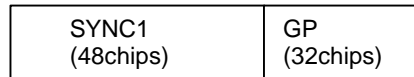
**Figure 5. Burst structure of UpPTS****Table 2. The Gold code sequences of SYNC1 for uplink pilot**

No.	Code sequences
0	
1	
2	
3	
4	
5	
6	
7	

5.1.2.3 Guard Period (GP)

The main guard period in switching point has the duration of 120.3us (163 chips).

5.2 Dedicated physical channel (DPCH)

The DCH are mapped onto the dedicated physical channel.

5.2.1 Spreading codes

Two options are being considered for the bursts that can be sent as described below. Both options allow a high degree of bit rate granularity and flexibility, thus allowing the implementation of the whole service range from low to high bit rate.

Spreading factor of and the number of codes for multicode transmission are assigned independently for uplink and downlink. The number of time slots is also assigned independently for uplink and downlink.

5.2.1.1 Multicode transmission with fixed spreading

Within each time slot of length 472.6 μ s, an additional separation of user signals by spreading codes is used. This means, that within one time slot of length 472.6 μ s, more than one burst of corresponding length as described in section 5.2.2 can be transmitted. These multiple bursts within the same time slot can be allocated to different users as well as partly or all to a single user. For the multiple bursts within the same time slot, different spreading codes are used to allow the distinction of the multiple bursts.

The bursts as described in section 5.2.2 are designed in such a way, that up to 16 bursts can be transmitted within one time slot, if the bursts are allocated to different users in the uplink.

5.2.1.2 Single code transmission with variable spreading

Within each time slot of length 472.6 us,

- A UE always uses single code transmission by adapting the spreading factor as a function of data rate. This limits the peak-to-average ratio of the modulated signal, and consequently the stress imposed to the power amplifier results in an improved terminal autonomy. Several UEs can be received by the base station in the same time slot, they are separated by their codes and the individual decoding can take profit of the joint detection.

5.2.2 Burst Types

As explained in the section 5.2.1, two options are being considered for the spreading. The bursts described in this section can be used for both options.

Three types of bursts for dedicated physical channels are defined: The burst type 1, the burst type 2 and the burst type 3. Both the burst type 1 and burst type 2 consist of two data symbol fields, a midamble of 144 chips and a guard period of 16 chips. The burst type 3 with SF=1 has no midamble and guard period, and is designed for transmitting high data rate information for fixed user in indoor environment.

The burst type 1 is suitable for the downlink, where maximum 16 different channel impulse responses have to be estimated. The burst type 2 can be used for the uplink. And the burst type 3 can be used for both uplink and downlink, if the bursts within a time slot are allocated to one user.

The data fields of the burst type 1 are 480 chips long, whereas the data fields of the burst type 2 are 448 chips long and the data fields of the burst type 3 are 640 chips long. The corresponding number of symbols depends on the spreading factor as indicated in Table 3 below. The guard period for the burst type 1 and type 2 is 16 chips period long.

The bursts type 1, type 2 and type 3 are shown from Figure 6 to Figure 8. The contents of the burst fields are described from Table 4 to Table 6.

Table 3. Number of symbols per data field in bursts 1, 2 and 3

Spreading factor (Q)	Number of symbols (N) per data field in Burst 1	Number of symbols (N) per data field in Burst 2	Number of symbols (N) in data field in Burst 3
1	240	208/240	640
2	120	104/120	-
4	60	52/60	-
8	30	26/30	-
16	15	13/15	-

Table 4. The contents of the burst type 1 fields

Chip number (CN)	Length of field in chips	Length of field in symbols	Length of field in μs	Contents of field
0-239	240	cf Table 3	177.2	Data symbols
240-383	144	-	106.3	Midamble
384-623	240	cf Table 3	177.2	Data symbols
624-639	16	-	11.8	Guard period

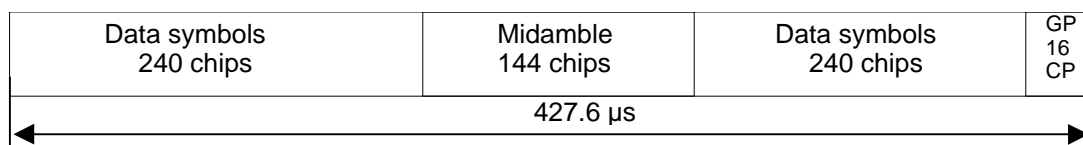

Figure 6. Burst structure of the burst type 1. GP denotes the guard period and CP the chip period.

Table 5. The contents of the burst type 2 fields

Chip number (CN)	Length of field in chips	Length of field in symbols	Length of field in μs	Contents of field
0-31	32	cf Table 3	23.6	SYNC2/EMPTY
32-239	208	-	153.6	Data symbols
240-383	144	cf Table 3	106.3	Midamble
384-623	240		177.2	Data symbols
624-639	16	-	11.8	Guard period

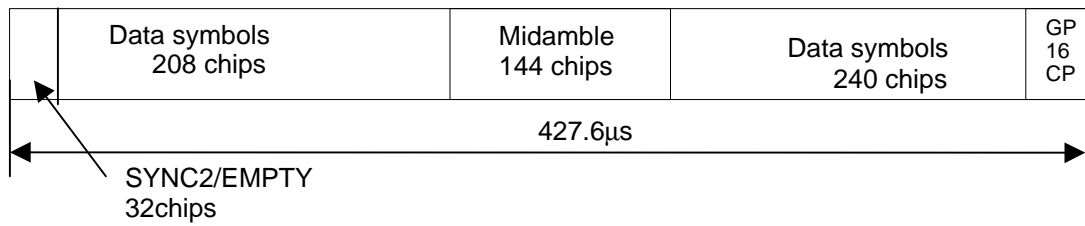

Figure 7. Burst structure of the burst type 2. GP denotes the guard period and CP the chip period.

Table 6. The contents of the burst type 3 fields

Chip number (CN)	Length of field in chips	Length of field in symbols	Length of field in μs	Contents of field
0-639	640	cf Table 3	427.6	Data symbols

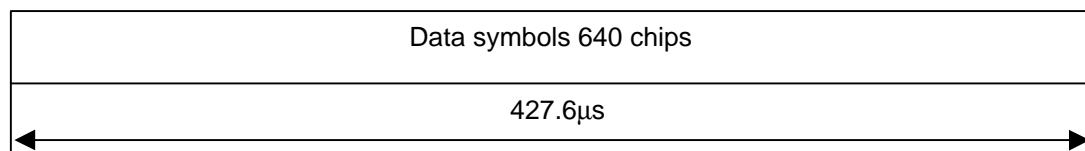

Figure 8. Burst structure of the burst type 3.

The three different bursts defined here are well suited for the different applications mentioned above. It may be possible to further optimize the burst structure for specific applications, for instance for unlicensed operation.

5.2.2.1 Transmission of L1 Control Signals

Both burst type 1 and burst type 2 for dedicated channels provide the possibility for transmission of L1 control signals in uplink and downlink respectively.

The transmission of L1 control signals is necessary in all communication procedures. As the initial design, it needs 6 symbols for burst type 1 and 4 symbols for burst type 2 respectively except in FACH and RACH which more symbols are required for L1 control signals. Hence the midamble structure and length is not changed. The L1 control signals are to be transmitted directly adjacent to the midamble, Figure 9 shows the position of the L1 control signals in traffic burst.

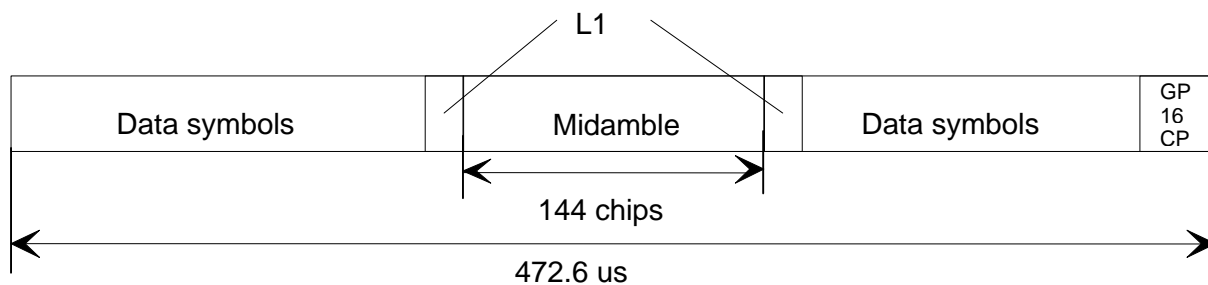

Figure 9. Position of L1 control signals in the traffic burst,

GP denotes the guard period and CP the chip period.

The L1 control signals are spread with the same spreading factor (SF) as the data parts. The SF of the burst which contains the L1 control signal is applied to both data and signalling and shall be constant, except when a negotiation between transmitter and receiver initiates a change of the SF. Variable Data Rates shall be handled by DTX.

5.2.2.2 Burst Structure when using DTX

<To be determined>

5.2.2.3 L1 Control Signals

<To be determined>

5.2.3 Training sequences for spread bursts

The training sequences, i.e. midamble, of different users active in the same time slot are time-shifted versions of one single periodic basic code. Different cells use different periodic basic codes, i.e. different midamble sets. In this way joint channel estimation for the channel impulse responses of all active users within one time slot can be done by one single cyclic correlation. The different user specific channel impulse response estimates are obtained sequentially in time at the output of the correlator. Following this principle it is shown hereafter how to derive the midamble from the periodic basic code.

Section 5.2.2 contains a description of the spread speech/data bursts. These bursts contain L_m midamble chips, which are also termed midamble elements. The L_m elements $m_i^{(k)}$; $i=1\dots L_m$; $k=1,\dots,K$; of the midamble codes $\underline{\mathbf{m}}^{(k)}$; $k=1,\dots,K$; of the K users are taken from the complex set

$$\underline{\mathbf{V}}_m = \{1, j, -1, -j\} \quad (1)$$

The elements $m_i^{(k)}$ of the complex midamble codes $\underline{\mathbf{m}}^{(k)}$ fulfil the relation

$$m_i^{(k)} = (j)^i \cdot m_i^{(k)} \quad m_i^{(k)} \in \{1, -1\}; i = 1, \dots, L_m; k = 1, \dots, K. \quad (2)$$

Hence, the elements $m_i^{(k)}$ of the complex midamble codes $\underline{\mathbf{m}}^{(k)}$ of the K users are alternating real and imaginary.

With W being the number of taps of the impulse response of the UE radio channels, the L_m binary elements $m_i^{(k)}$; $i = 1, \dots, L_m$; $k = 1, \dots, K$; of (2) for the complex midamble $\underline{\mathbf{m}}^{(k)}$; $k=1,\dots,K$; of the K users are generated according to Steiner's method [1] from a single periodic basic code

$$\underline{\mathbf{m}} = (m_1, m_2, \dots, m_{L_m + (K-1)W})^T \quad m_i \in \{1, -1\}; i = 1, \dots, (L_m + (K-1)W). \quad (3)$$

The elements m_i ; $i = 1, \dots, (L_m + (K-1)W)$, of (3) fulfil the relation

$$m_i = m_{i-P} \quad \text{for the subset } i = (P+1), \dots, (L_m + (K-1)W). \quad (4)$$

The P elements m_i ; $i = 1, \dots, P$, of one period of m according to (3) are contained in the vector

$$\underline{\mathbf{m}}_p = (m_1, m_2, \dots, m_p)^T. \quad (5)$$

With $\underline{\mathbf{m}}$ according to (3) the L_m binary elements $m_i^{(k)}$; $i = 1, \dots, L_m$; $k = 1, \dots, K$; of (2) for the midamble of the K users are generated based on Steiner's formula

$$m_i^{(k)} = m_{i+(K-k)W} \quad i = 1, \dots, L_m; k = 1, \dots, K. \quad (6)$$

In the following the term 'a midamble code set' or 'a midamble code family' denotes K specific midamble codes $\underline{\mathbf{m}}^{(k)}$; $k=1,\dots,K$. Different midamble code sets $\underline{\mathbf{m}}^{(k)}$; $k=1,\dots,K$; are in the following specified based on different periods $\underline{\mathbf{m}}_p$ according (5).

In adjacent cells of the cellular UE radio system, different midamble codes sets $\underline{\mathbf{m}}^{(k)}$; $k=1,\dots,K$; should be

used to guarantee a proper channel estimation.

As mentioned above a single midamble code set $\underline{\mathbf{m}}^{(k)}$; $k=1,\dots,K$; consisting of K midamble codes is based on a single period \mathbf{m}_p according to (5).

In the following several exemplary periods \mathbf{m}_p according (5) which can be used to generate different midamble code sets $\underline{\mathbf{m}}^{(k)}$; $k=1,\dots,K$; will be listed in tables in a hexadecimal representation. As shown in Table 7 always 4 binary elements m_i are mapped on a single hexadecimal digit.

Table 7. Mapping of 4 binary elements m_i on a single hexadecimal digit

4 binary elements m_i	mapped on hexadecimal digit
-1 -1 -1 -1	0
-1 -1 -1 1	1
-1 -1 1 -1	2
-1 -1 1 1	3
-1 1 -1 -1	4
-1 1 -1 1	5
-1 1 1 -1	6
-1 1 1 1	7
1 -1 -1 -1	8
1 -1 -1 1	9
1 -1 1 -1	A
1 -1 1 1	B
1 1 -1 -1	C
1 1 -1 1	D
1 1 1 -1	E
1 1 1 1	F

The mean degradation's [2, equation (38)] which serve as a quality information of the periods \mathbf{m}_p according to (5) and hence of the specified midamble code sets $\underline{\mathbf{m}}^{(k)}$; $k=1,\dots,K$; will be also given.

5.2.3.1 Example Midamble Code Set for Burst Type 1 and Type 2

In the case of burst type 1 (see section 5.2.2) the midamble has a length of $L_m=144$, which is corresponding to:

$K=?$; $W=?$; $P=?$

Table 8. Example Periods \mathbf{m}_p according (8-5)

Periods \mathbf{m}_p of length $P=?$	Degradation in dB

5.2.3.2 Midamble Transmit Power

In principle, the midamble transmit power would be the same as the data symbols in the same burst.

5.3 Common control physical channels (CCPCH)

5.3.1 Downlink common control physical channel

The BCH, the PCH or the FACH as described in section 4.1.2 are mapped onto one or more downlink common control physical channels (CCPCH). In such a way the capacity of BCH, PCH and FACH can be adopted depending on the operator's requirement.

5.3.1.1 Spreading codes

The downlink CCPCH uses fixed spreading with a spreading factor $SF = 16$ as described in section 5.2.1.1.

5.3.1.2 Burst Types

The bursts as described in section 5.2.2 are used for the downlink CCPCH.

5.3.1.3 Training sequences for spread bursts

The training sequences, i.e. midamble, as described in section 5.2.3 are used for the downlink CCPCH.

5.3.2 The physical random access channel (PRACH)

The RACH as described in section 4.1.2 are mapped onto one or more uplink physical random access channels (PRACH). In such a way the capacity of RACH can be adopted depending on the operator's requirement.

5.3.2.1 Spreading codes

The uplink PRACH uses fixed spreading with a spreading factor $SF = 16$ as described in section 5.2.1.1.

5.3.2.2 Burst Types

The UEs send the uplink access bursts randomly in the uplink PRACH. This leads to collision groups. The usage of maximum 8 orthogonal spreading codes in the first main uplink time slot increases the amount of collision groups and throughput, respectively.

A further improvement is achieved by using a set of Gold codes in the UpPTS time slot. Because the PRACH is only located in the first main uplink time slot, which can transmit more than one RACH within one time slot without collision. When a UE attempts to send the uplink access burst, it would simultaneously choose any one spreading code in the first main uplink time slot and any one Gold code in the UpPTS time slot by random. The possibility of collision would be very low because of the orthogonal performance of the two sets of codes.

Although the maximum 8-pair orthogonal codes may be available by design, the actual working number of the codes would be decided by operator.

The burst structure for PRACH is shown in Figure 9 and Table 9 respectively.

Table 9. The burst structure for PRACH

Chip Number (CN)	Length of field in chips	Length of field in symbols	Length of field in μs	Contents of field
0-31	32	2	23.6	EMPTY
32-239	208	13	153.6	Data symbols
240-383	144	9	106.3	Midamble
384-623	240	15	177.2	Data symbols
624-639	16	1	11.8	Guard period

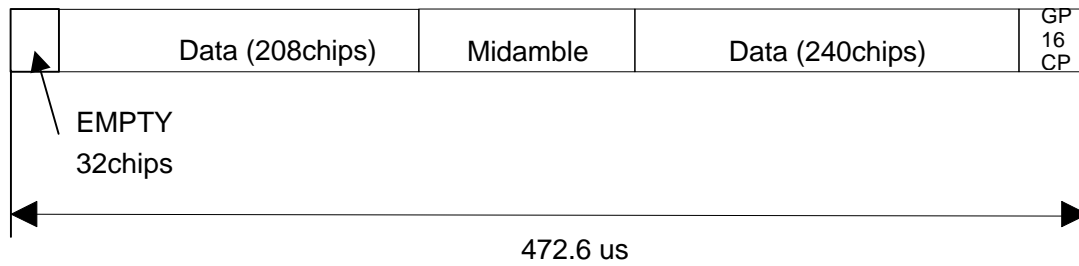

Figure 10. Access burst, GP denotes the guard period and CP the chip period.

5.3.2.3 Training sequences for access bursts

The training sequences, i.e. midamble, as described in section 5.2.3 are used for the uplink PRACH.

5.4 The physical synchronization channel (PSCH)

As described in section 5.1.2, the PSCH is located that:

The downlink PSCH is located in DwPTS as shown in Figure 2,

The uplink PSCH is located in UpPTS as shown in Figure 2,

And the SYNC2/EMPTY field in burst type 2 is another uplink PSCH that maintains the uplink synchronization as shown in Figure 7.

[Editors Note: The DwPTS, UpPTS time slots and SYNC2/EMPTY field in main uplink time slots are added by WTS WG1.]

6 Mapping of transport channels to physical channels

This section describes the way, in which transport channels are mapped onto physical resources, see Figure 11.

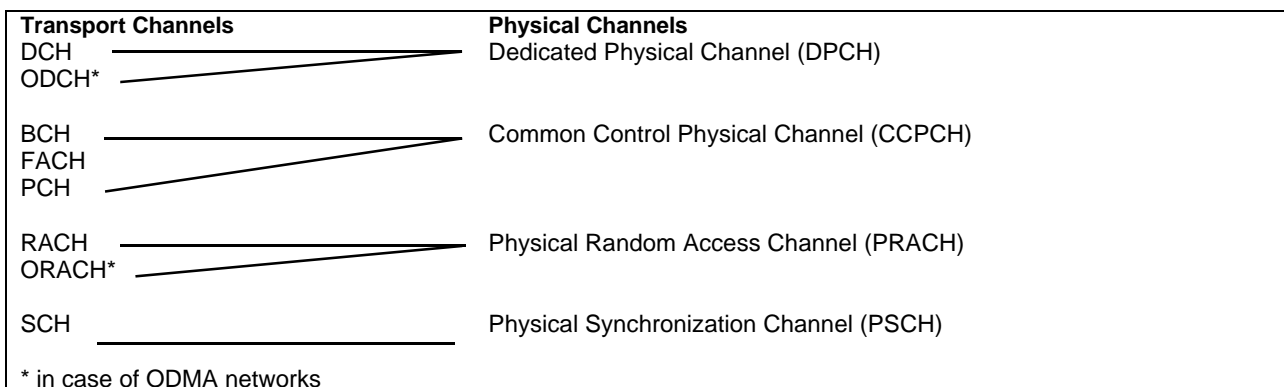
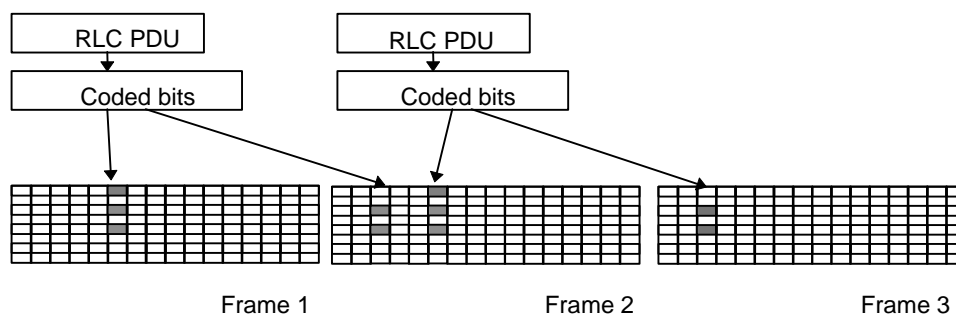

Figure 11. Transport channel to physical channel mapping

In the sequel, we use the term's physical channel and resource unit (RU), a physical channel is defined as the association of one code, one time slot and one frequency. A resource unit (RU) is that part of a physical channel allocated for one subframe.

6.1 Dedicated Transport Channels

A dedicated transport channel is mapped onto one or more sets of time slots and codes within a subframe. An interleaving period is associated with each allocation. The subframe is subdivided into time slots that are available for uplink and downlink information transfer. Each set of time slots and codes over an interleaving period maps to a data unit and a data unit can correspond to one or more FEC code blocks and one or more RLC protocol data units dependent from the service being supported. The mapping is illustrated by the following diagram (Figure 12):

**Figure 12. Mapping of PDU onto the physical bearer**

For NRT packet data services an allocation is made only for a relatively short period of time. In general, for RT services an allocation is made for a certain time period and a release procedure is necessary to release the resource. For the efficient use of resources the time slot/ code set allocated to a radio bearer may be changed from time to time and the resources allocated to a VBR service may increase or decrease along with the changes in the data rate. Traffic channels are power controlled.

6.2 Common Transport Channels

6.2.1 The Broadcast Channel (BCH)

The BCH is mapped on one RU in the first downlink time slot per subframe. The BCH has higher transmission power level (9-11dB higher than average power level in one RU) with omnidirectional or sectorial pattern (without beamforming). The RU allocated by BCH would be shared with other common control channels: PCH, according to a superframe structure.

6.2.2 The Paging Channel (PCH)

The PCH would be mapped onto the same location as BCH. The PCH is always transmitted with the same power level and antenna pattern as those of the BCH.

6.2.3 The Forward Access Channel (FACH)

The FACH can be mapped onto more than one (up to 8) RU in the first downlink time slot per subframe. The location of the FACH is indicated on the BCH. FACH may or may not be power controlled. FACH has average transmission power level and its radiation pattern is beam formed.

6.2.4 The Random Access Channel (RACH)

The RACH is mapped onto more than one (up to 8) RU in the first uplink time slot per subframe. The same

time slot may be used for RACH by more than one cell. Multiple transmissions using different codes could be received in parallel. The location allocated to RACH in the time slots is indicated on the BCH. The RACH uses both power control and uplink synchronization control.

6.2.5 The Synchronization Channel (SCH)

The SCH is mapped onto the PSCH as described in section 5.4.

6.3 Multiframe structure

A strong requirement for the multiframe structure comes from the realization of low cost dual-mode FDD-TDD terminals and from the GSM compatibility of the UTRA proposal. In this respect the superframe and multiframe structure for TDD and FDD mode have to be compatible and harmonised with GSM.

Thus in the proposed structure a superframe is composed of 72 radio frames each of length 10 ms. So the superframe period is 720 ms.

All frames in the traffic channel multiframe are used to carry both user data and dedicated signalling. The TDD superframe matches exactly a FDD multiframe ensuring the compatibility of both modes.

History

Document history		
V0.1.0	1999-04	Document created based on the documents CATT TD-SCDMA RTT V 0.5
V1.0.0	1999-05-12	Document updated based on the 3GPP S1.21 V2.0.0 and the discussion between Siemens and CATT. This draft has been discussed in the CWTS WG1 Ad Hoc1#1 meeting, Beijing, May 12th, 1999.
V1.1.0	1999-05-21	Document updated based on the CWTS WG1#3 meeting, Beijing, May 21st, 1999.

Editor for C1.21, Physical channels and mapping of transport channels onto physical channels (TD-SCDMA), is:

Dr. Shihe Li

CATT

Email: zhangdj@pub.xinwei.com.cn

This document is written in Microsoft Word 97.