

Source: Nokia

DSCH power control improvement in Soft Handover:

Proposed Draft TR

Introduction

This contribution contains the proposed draft TR on the proposal "DSCH power control improvement in soft handover, which is under the study item "Radio link performance enhancements" in TSG RAN WG1.

If WG1 agrees to proceed from the study item phase to the CR phase (and to recommend TSG RAN to make the proposal a proper WI) then this TR (or revised version of this) is proposed to be provided for the next TSG RAN, as well as to TSG RAN WG2 & WG3 as an attachment of the LS informing about the WG view.

For the general WG1 contribution on the topic, please refer to the Tdoc R1-00-1025

3G TR 25.xxx V0.0.1 (2000-08)

(Proposed Technical Report)



3rd Generation Partnership Project Technical Specification Group Radio Access Network; DSCH power control improvement in soft handover (Release 2000)

The present document has been developed within the 3rd Generation Partnership Project (3GPP™) and may be further elaborated for the purposes of 3GPP.

The present document has not been subject to any approval process by the 3GPP Organisational Partners and shall not be implemented.

This Specification is provided for future development work within 3GPP only. The Organisational Partners accept no liability for any use of this Specification.

Specifications and reports for implementation of the 3GPP™ system should be obtained via the 3GPP Organisational Partners' Publications Office.

Keywords

<keyword[, keyword]>

3GPP

Postal address

3GPP support office address

650 Route des Lucioles - Sophia Antipolis
Valbonne - FRANCE
Tel.: +33 4 92 94 42 00 Fax: +33 4 93 65 47 16

Internet

<http://www.3gpp.org>

Copyright Notification

No part may be reproduced except as authorized by written permission.
The copyright and the foregoing restriction extend to reproduction in all media.

© 2000, 3GPP Organizational Partners (ARIB, CWTS, ETSI, T1, TTA, TTC).
All rights reserved.

Contents

Foreword	5
1 Scope	6
2 References	6
3 Definitions, symbols and abbreviations.....	6
3.1 Definitions.....	6
3.2 Symbols.....	6
3.3 Abbreviations	6
4 Background and Introduction	6
5 Changes over the Release –99 specification based equipment for the proposed method.....	6
5.1 Changes with respect to Release 99	6
5.1.1 Required Changes in UE.....	6
5.1.2 Required Changes in Node B	7
5.2 Expected Gain with respect to Release 99.....	7
6 DSCH Power Control Improvement	7
7 Impacts to other RAN specifications.....	8
7.1 WG1.....	8
7.2 WG2.....	11
7.3 WG3.....	11
7.4 WG4.....	12
8 Backward Compatibility.....	13
History.....	13

Foreword

This Technical Specification has been produced by the 3rd Generation Partnership Project (3GPP). The contents of the present document are subject to continuing work within the TSG and may change following formal TSG approval. Should the TSG modify the contents of the present document, it will be re-released by the TSG with an identifying change of release date and an increase in version number as follows:

Version x.y.z

where:

- x the first digit:
 - 1 presented to TSG for information;
 - 2 presented to TSG for approval;
 - 3 or greater indicates TSG approved document under change control.
- y the second digit is incremented for all changes of substance, i.e. technical enhancements, corrections, updates, etc.
- z the third digit is incremented when editorial only changes have been incorporated in the document.

1 Scope

This document is the draft proposed Technical Report for the DSCH power control improvement in soft handover, part of the Release 2000 study item "Radio Link Performance Improvement".

2 References

The following documents contain provisions which, through reference in this text, constitute provisions of the present document.

- References are either specific (identified by date of publication, edition number, version number, etc.) or non-specific.
- For a specific reference, subsequent revisions do not apply.
- For a non-specific reference, the latest version applies.

[1] 3G TS 25.211 (V3.2.0): "Example 1, using sequence field".

3 Definitions, symbols and abbreviations

3.1 Definitions

For the purposes of the present document, the following terms and definitions apply.

Example: text used to clarify abstract rules by applying them literally.

3.2 Symbols

3.3 Abbreviations

For the purposes of the present document, the following abbreviations apply:

DCH	Dedicated Channel
DPCCH	Dedicated Physical Control Channel
FBI	Feedback Information
PDSCH	Physical Downlink Shared Channel
SSDT	Site Selection Diversity Transmission
SHO	Soft Handover
DSCH	Downlink Shared Channel

4 Background and Introduction

Under the study item "Radio Link Performance Improvement", the proposal for "DSCH power control improvement in soft handover" has been discussed in TSG RAN WG1. In this technical report, the details of the proposed method are presented as well as the required changes in different specifications in TSG RAN specifications.

5 Changes over the Release –99 specification based equipment for the proposed method

This section covers the expected changes for the Release –99 based equipment to support the feature.

5.1 Changes with respect to Release 99

5.1.1 Required Changes in UE

At the UE side the new "capability" needed is to be able to do the normal soft handover even when sending the SSDT signalling in the uplink direction. This should not be a hardware issue; thus the incremental complexity is very small.

Both such a "normal" SHO combining and SSDT signalling are "mandatory" requirements for the UE in Release –99.

5.1.2 Required Changes in Node B

For the Node B side the proposed method is giving a possibility to improve the resulting performance in setting the DSCH power level and from Release –99 specification the added complexity is also very small as only the power control algorithm in the Node B (for DSCH) would need to be modified.

In general it is also worth noting that this kind of item is optional in the Node B (or UTRAN in general).

5.2 Expected Gain with respect to Release 99

The performance improvements can be considered coming from the following case:

With the proposed method, The DSCH would be sent with more accurate power level, as UTRAN would utilise the information from the SSdT to see if the Node B/cell sending the DSCH is the strongest one. In the worst case with DSCH being sent from the weakest Node B, the DSCH power level could be 6-10dB below the desired power level. This corresponds also to a more or less non-power controlled case or random power controlled case as the associated DCH is not the basis for the power control commands generated by the UE.

6 DSCH Power Control Improvement

In this section, the method for the DSCH power control improvement is described.

The proposed intends to allow the improvement of DSCH power control in soft handover by the use of the existing SSdT signalling in the uplink to determine whether DSCH power should follow the DCH (primary cell transmitting) or whether the DSCH power should be set with higher offset (or fixed value like for FACH (Forward Access Channel) for example) in case secondary cell is transmitting.

The SSdT has been specified in section 5.2.1.4 in TS 25.214 and according to the principle UE provides indication of the primary cell ID for in the uplink FBI field. This feature is considered as baseline feature and provided by all UEs (that can use dedicated channels) in the Release –99 as well. The intention with SSdT is that only the primary cell sends the DPDCH part of the downlink DCH, while DPCCH part is sent by the all Node Bs in the active set.

In the proposed enhancement, the UTRAN may activate the uplink SSdT signalling even the SSdT transmission is not necessary used on the downlink DCH. The Node Bs are given power offset value that is used whether the DSCH is sent from the Node B determined to be the primary Node B (or cell) or whether the Node B sending the DSCH is the secondary one. The primary/secondary status would be determined with sliding average for example over 10 frames with parameter given (over lub) how many primary indications are needed to use the primary value power offset for DSCH.

The existing maximum/minimum power level values would be naturally valid, thus allowing to set the DSCH e.g. to be 6 dB over DCH but not to exceed the power level determined as being needed for example with FACH transmission.

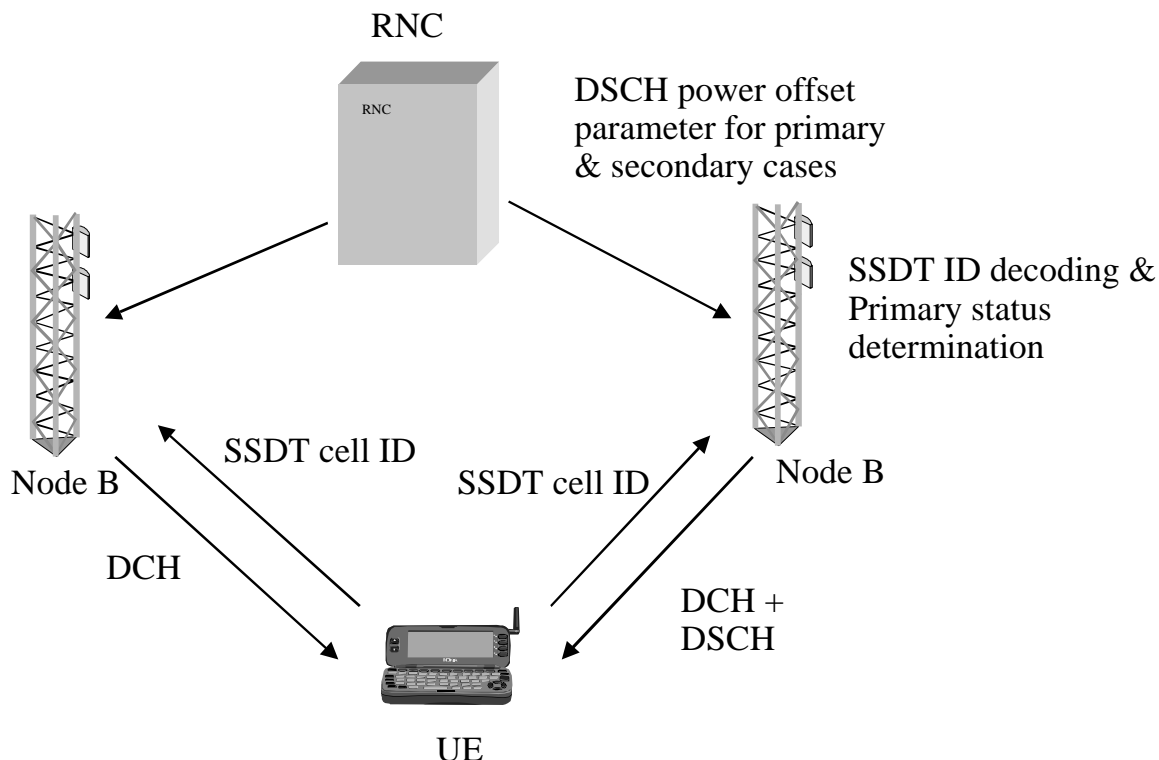

Figure 1. Concept of using SSdT signalling with DSCH power control

7 Impacts to TSG RAN specifications

7.1 WG1

This section contains the draft changes to TSG RAN WG1 TS 25.214.

5.2.1.4 Site selection diversity transmit power control

5.2.1.4.1 General

Site selection diversity transmit power control (SSdT) is an optional macro diversity method in soft handover mode.

Operation is summarised as follows. The UE selects one of the cells from its active set to be 'primary', all other cells are classed as 'non primary'. The main objective is to transmit on the downlink from the primary cell, thus reducing the interference caused by multiple transmissions in a soft handover mode. A second objective is to achieve fast site selection without network intervention, thus maintaining the advantage of the soft handover. In order to select a primary cell, each cell is assigned a temporary identification (ID) and UE periodically informs a primary cell ID to the connecting cells. The non-primary cells selected by UE switch off the transmission power. The primary cell ID is delivered by UE to the active cells via uplink FBI field. SSdT activation, SSdT termination and ID assignment are all carried out by higher layer signalling.

UTRAN may also command UE to use SSdT signalling in the uplink although cells would transmit the downlink as without SSdT active. The downlink operation mode for SSdT is set by higher layers. UTRAN may use the SSdT information for the PDSCH power control as specified in section 5.2.2.

5.2.1.4.1.1 Definition of temporary cell identification

Each cell is given a temporary ID during SSdT and the ID is utilised as site selection signal. The ID is given a binary bit sequence. There are three different lengths of coded ID available denoted as "long", "medium" and "short". The network decides which length of coded ID is used. Settings of ID codes for 1-bit and 2-bit FBI are exhibited in table 3 and table 4, respectively.

Table 3: Settings of ID codes for 1 bit FBI

ID label	ID code		
	"long"	"medium"	"short"
a	0000000000000000	(0)0000000	00000
b	101010101010101	(0)1010101	01001
c	011001100110011	(0)0110011	11011
d	110011001100110	(0)1100110	10010
e	000111100001111	(0)0001111	00111
f	101101001011010	(0)1011010	01110
g	011110000111100	(0)0111100	11100
h	110100101101001	(0)1101001	10101

Table 4: Settings of ID codes for 2 bit FBI

ID label	ID code (Column and Row denote slot position and FBI-bit position.)		
	"long"	"medium"	"short"
a	(0)0000000	(0)000	000
	(0)0000000	(0)000	000
b	(0)0000000	(0)000	000
	(1)1111111	(1)111	111
c	(0)1010101	(0)101	101
	(0)1010101	(0)101	101
d	(0)1010101	(0)101	101
	(1)0101010	(1)010	010
e	(0)0110011	(0)011	011
	(0)0110011	(0)011	011
f	(0)0110011	(0)011	011
	(1)1001100	(1)100	100
g	(0)1100110	(0)110	110
	(0)1100110	(0)110	110
h	(0)1100110	(0)110	110
	(1)0011001	(1)001	001

ID must be terminated within a frame. If FBI space for sending a given ID cannot be obtained within a frame, hence if the entire ID is not transmitted within a frame but must be split over two frames, the first bit(s) of the ID is(are) punctured. The relating bit(s) to be punctured are shown with brackets in table 3 and table 4.

5.2.1.4.2 TPC procedure in UE

The TPC procedure of the UE in SSdT is identical to that described in subclause 5.2.1.2 or 5.2.1.3 in compressed mode.

5.2.1.4.3 Selection of primary cell

The UE selects a primary cell periodically by measuring the RSCP of CPICHs transmitted by the active cells. The cell with the highest CPICH RSCP is detected as a primary cell.

5.2.1.4.4 Delivery of primary cell ID

The UE periodically sends the ID code of the primary cell via portion of the uplink FBI field assigned for SSdT use (FBI S field). A cell recognises its state as non-primary if the following conditions are fulfilled simultaneously:

- the received primary ID code does not match with the own ID code;
- the received uplink signal quality satisfies a quality threshold, Q_{th} , a parameter defined by the network;
- and when the use of uplink compressed mode does not result in excessive levels of puncturing on the coded ID. The acceptable level of puncturing on the coded ID is less than $(int)N_{ID}/3$ symbols in the coded ID, where N_{ID} is the length of the coded ID.

Otherwise the cell recognises its state as primary.

The state of the cells (primary or non-primary) in the active set is updated synchronously. If a cell receives the last portion of the coded ID in uplink slot j , the state of cell is updated in downlink slot

$(j+1+T_{os}) \bmod 15$, where T_{os} is defined as a constant of 2 time slots. The updating of the cell state is not influenced by the operation of downlink compressed mode.

At the UE, the primary ID code to be sent to the cells is segmented into a number of portions. These portions are distributed in the uplink FBI S-field. The cell in SSdT collects the distributed portions of the primary ID code and then detects the transmitted ID. The period of the primary cell update depends on the settings of the code length and the number of FBI bits assigned for SSdT use as shown in table 5.

Table 5: Period of primary cell update

code length	The number of FBI bits per slot assigned for SSdT	
	1	2
"long"	1 update per frame	2 updates per frame
"medium"	2 updates per frame	4 updates per frame
"short"	3 updates per frame	5 updates per frame

5.2.1.4.5 TPC procedure in the network

In SSdT, a non-primary cell can switch off its DPDCH output (i.e. no transmissions).

The cell manages two downlink transmission power levels, P1, and P2. Power level P1 is used for downlink DPCCH transmission power level and this level is updated as the same way specified in 5.2.1.2 or 5.2.1.3 in compressed mode regardless of the selected state (primary or non-primary). The actual transmission power of TFCI, TPC and pilot fields of DPCCH is set by adding P1 and the offsets PO1, PO2 and PO3, respectively, as specified in 5.2.1.1. P2 is used for downlink DPDCH transmission power level and this level is set to P1 if the cell is selected as primary, otherwise P2 is switched off. The cell updates P1 first and P2 next, and then the two power settings P1 and P2 are maintained within the power control dynamic range. Table 6 summarizes the updating method of P1 and P2.

Table 6: Updating of P1 and P2

State of cell	P1 (DPCCH)	P2 (DPDCH)
non primary	Updated by the same way as specified in 5.2.1.2 or 5.2.1.3 in compressed mode	Switched off
primary		= P1

5.2.2 PDSCH

The PDSCH power control can be based on the following solutions, which are selectable, by the network:

- Inner-loop power control based on the power control commands sent by the UE on the uplink DPCCH.
- Slow power control.

UTRAN may use the SSdT signalling to determine the which power offset to use for PDSCH with respect to the associated downlink DCH when more than one cell may be in the active set. The PDSCH power offset value to be used with respect the associated DCH depends whether the cell transmitting PDSCH is determined to be a primary one or not. The power offset values for both cases, cell being primary (*primary_DSCH_pow*) and cell being non-primary (*non-primary_DSCH_pow*), are given by the network. The SSdT commands sent by the UE are averaged in UTRAN side over one or more frames. The averaging window length parameter in the number frames to average over, *SSdT_aveg_window*, and the parameter for the required number of received primary SSdT commands, *SSdT_primary_commands*, during the averaging window for declaring primary status are given by higher layers. If the number of received commands during the averaging window is less than the parameter, then offset given for the non-primary case is used.

7.2 WG2

The possibility to use SSdT signalling without SSdT transmission in the downlink needs small modification in the SSdT information elements in RRC specification. This means adding one additional parameter in addition to the ID lengths currently covered in RRC specification (25.331 in TSG RAN WG2). The SSdT code word parameters would remain unchanged.

The following parameter list needs to be extended in 25.331 with the parameter SSdT transmission in the downlink (on/off).

10.3.6.67 SSdT information

NOTE: Only for FDD.

This information element indicates the status (e.g. initiated/terminated) of the Site Selection. Diversity Transmit power control (SSdT). It is used to change the SSdT status. The parameter 'code word set' indicates how cell identities are coded (using many bits or few, values are long, medium, or short).

Information Element/Group name	Need	Multi	Type and reference	Semantics description
S field	MP		Integer (1, 2)	in bits
Code Word Set	MP		Enumerated (long, medium, short, SSdT off)	

7.3 WG3

For the lub/lur (NBAP/RNSAP) specifications (25.433&25.432) the power offset parameters for the primary and secondary cases as well as the averaging window parameters for the primary/secondary status determination from the SSdT commands sent in the uplink FBI (Feedback Information) field, would need to be added.

For the lub the following command list would need to be extended to cover the SSdT activity for the downlink separately. (not active, active in both directions, active in the uplink only) instead with the current active/not active.

For the averaging window parameters at Node B the range [1..10] frames and [1..50] primary SSdT commands are proposed. (The latter range is larger as there can be from 1 to 5 updates of SSdT status per frame depending on the SSdT ID length)

The following parameters are from 25.433 version 3.2.0

9.2.2.47 SSdT Indication

The SSdT Indication indicates whether SSdT is in use by the UE or not.

IE/Group name	Presence	Range	IE type and reference	Semantics description
SSdT Indication			ENUMERATED(SSdT Active in the UE, SSdT not Active in the UE)	

9.2.2.48 STTD Indicator

Indicates if STTD shall be active or not.

IE/Group Name	Presence	Range	IE type and reference	Semantics description
STTD Indicator			ENUMERATED(active, inactive)	

For the lur the similar addition would need to be done for the following parameter list for the parameters with respect the downlink operation, the UE parameter would be unchanged. Thus SSDT support indication and SSDT activity indication would need to take the downlink separately as with lub (not supported/supported/supported in the uplink only)
The following parameters are from 25.423 version 3.2.0

9.2.2.42 SSDT Indication

The SSDT Indication indicates whether SSDT is in use by the UE or not.

IE/Group Name	Presence	Range	IE type and reference	Semantics description
SSDT Indication			ENUMERATED(SSDT Active in the UE, SSDT not Active in the UE)	

9.2.2.43 SSDT Support Indicator

The SSDT Support Indicator indicates whether a RL supports SSDT or not.

IE/Group Name	Presence	Range	IE type and reference	Semantics description
SSDT Support Indicator			ENUMERATED (SSDT Supported, SSDT not supported).	

9.2.2.44 STTD Indicator

Indicates if STTD is active or not.

IE/Group Name	Presence	Range	IE type and reference	Semantics description
STTD Indicator			ENUMERATED(active, inactive)	

9.2.2.45 STTD Support Indicator

The STTD Support Indicator indicates whether the STTD can be applied to DL DPCH in the cell or not.

IE/Group Name	Presence	Range	IE type and reference	Semantics description
STTD Support Indicator			ENUMERATED (STTD Supported, STTD not Supported).	

7.4 WG4

No impacts foreseen at this point for Release –00.

8 Backward Compatibility

The proposal is backwards compatible with Release –99 UEs. Release –99 terminals can operate in Release 2000 network and respectively Release 2000 terminals may operate with Release –99 Node Bs where this feature is not available This is simple to justify as the proposal uses existing SSDT signalling in the uplink which is used to improve the performance in setting the power offset for DSCH frame for particular UE. The form of the downlink transmission in case of DCH (is SSDT applied or not), which is not causing any issues between UEs and occurs in Release –99 as well between different UEs as well.

History

Document history		
Date	Version	Comment
	0.0.0	
Editor for 3G TR xx.xxx is:		
Tel. :		
Fax :		
Email :		
This document is written in Microsoft Word version.		

Annex <X>:
Change history

Change history							
Date	TSG #	TSG Doc.	CR	Rev	Subject/Comment	Old	New