

# TR 25.944 V1.0.1 (2000-02)

---

*Technical Report*

**3<sup>rd</sup> Generation Partnership Project (3GPP);  
Technical Specification Group (TSG);  
Radio Access Network (RAN);  
Working Group 1 (WG1);  
Channel coding and multiplexing examples**

---



The present document has been developed within the 3<sup>rd</sup> Generation Partnership Project (3GPP™) and may be further elaborated for the purposes of 3GPP.

The present document has not been subject to any approval process by the 3GPP Organisational Partners and shall not be implemented.

This Specification is provided for future development work within 3GPP only. The Organisational Partners accept no liability for any use of this Specification. Specifications and reports for implementation of the 3GPP™ system should be obtained via the 3GPP Organisational Partners' Publications Offices.

---

---

Reference

<Workitem>  
(<Shortfilename>.PDF)

---

Keywords

<keyword[, keyword]>

**3GPP**

---

Postal address

---

Office address

---

Internet

secretariat@3gpp.org  
Individual copies of this deliverable  
can be downloaded from  
<http://www.3gpp.org>

---

**Copyright Notification**

No part may be reproduced except as authorized by written permission.  
The copyright and the foregoing restriction extend to reproduction in all media.

©  
All rights reserved.

---

# Contents

Intellectual Property Rights .....	5
Foreword.....	5
1 Scope.....	6
2 References .....	6
3 Definitions, symbols and abbreviations.....	6
3.1 Definitions.....	6
3.2 Symbols.....	6
3.3 Abbreviations.....	6
4 Channel coding and multiplexing examples .....	8
4.1 FDD mode .....	8
4.1.1 Downlink.....	8
4.1.1.1 BCH .....	8
4.1.1.2 Example for PCH and FACH.....	9
4.1.1.3 Example for DCH.....	10
4.1.1.3.1 DCH-> Radio frame segmentation.....	10
4.1.1.3.1.1 Example for 4.1 kbps data.....	10
4.1.1.3.1.2 Example for 12.2 kbps data.....	11
4.1.1.3.1.3 Example for 64/128/384 kbps packet data .....	12
4.1.1.3.1.4 Example for 64 kbps data.....	13
4.1.1.3.2 TrCh multiplexing -> Physical channel mapping.....	14
4.1.1.3.2.1 Example for Stand-alone mapping of 4.1 kbps data .....	14
4.1.1.3.2.2 Example for multiplexing of 12.2 kbps data and 4.1 kbps data.....	15
4.1.1.3.2.3 Example for multiplexing of 64/128/384 kbps packet data and 4.1 kbps data.....	16
4.1.1.3.2.4 Example for multiplexing of 64 kbps data and 4.1 kbps data.....	18
4.1.2 Uplink .....	19
4.1.2.1 Example for RACH .....	19
4.1.2.2 Example for DCH.....	20
4.1.2.2.1 DCH -> Radio frame segmentation.....	20
4.1.2.2.1.1 Example for 4.1 kbps data.....	20
4.1.2.2.1.2 Example for 12.2 kbps data.....	21
4.1.2.2.1.3 Example for 64/128/384 kbps packet data .....	22
4.1.2.2.1.4 Example for 64 kbps data.....	23
4.1.2.2.2 TrCH multiplexing -> Physical channel mapping.....	24
4.1.2.2.2.1 Example for Stand-alone mapping of 4.1 kbps data .....	24
4.1.2.2.2.2 Example for multiplexing of 12.2 kbps data and 4.1 kbps data.....	25
4.1.2.2.2.3 Example for multiplexing of 64/128/384 kbps packet data and 4.1 kbps data.....	26
4.1.2.2.2.4 Example for multiplexing of 64 kbps data and 4.1 kbps data.....	27
4.2 TDD mode .....	28
4.2.1 Downlink.....	28
4.2.1.1 BCH 28 .....	28
4.2.1.2 Example for PCH .....	29
4.2.1.3 Example for FACH.....	30
4.2.1.4 Example for DCH.....	31
4.2.1.4.1 DCH-> Radio frame segmentation.....	31
4.2.1.4.1.1 Example for 2.4 kbps data.....	31
4.2.1.4.1.2 Example for 12.2 kbps data.....	32
4.2.1.4.1.3 Example of 64/128/384 kbps packet data.....	33

4.2.1.4.1.4	Example for 64 kbps data.....	34
4.2.1.4.2	TrCH multiplexing -> Physical channel mapping .....	35
4.2.1.4.2.1	Example for Stand-alone mapping of 2.4 kbps data .....	35
4.2.1.4.2.2	Example for multiplexing of 12.2 kbps data and 2.4 kbps data.....	36
4.2.1.4.2.3	Example for multiplexing of 64/128/384 kbps packet data and 2.4 kbps data.....	37
4.2.1.4.2.4	Example for multiplexing of 64 kbps data and 2.4 kbps data.....	38
4.2.2	Uplink .....	39
4.2.2.1	RACH.....	39
4.2.2.2	Example for DCH.....	40
4.2.2.2.1	DCH-> Radio frame segmentation.....	40
4.2.2.2.2	TrCH multiplexing -> Physical channel mapping .....	41
4.2.2.2.2.1	Example for Stand-alone mapping of 2.4 kbps data .....	41
4.2.2.2.2.2	Example for multiplexing of 12.2 kbps data and 2.4 kbps data.....	42
4.2.2.2.2.3	Example for multiplexing of 64/128/384 kbps packet data and 2.4 kbps data.....	43
4.2.2.2.2.4	Example for multiplexing of 64 kbps data and 2.4 kbps data.....	45
5	History.....	46

---

## Intellectual Property Rights

*<IPR notice shall be provided once correct notice is available within 3GPP>*

---

### Foreword

This Technical Report has been produced by the 3<sup>rd</sup> Generation Partnership Project, Technical Specification Group Radio Access Network, Working Group 1 (3GPP TSG RAN WG1).

The contents of this TR may be subject to continuing work within the 3GPP and may change following formal TSG approval. Should the TSG modify the contents of this TR, it will be re-released with an identifying change of release date and an increase in version number as follows:

Version m.x.y

where:

m indicates [major version number]

x the second digit is incremented for all changes of substance, i.e. technical enhancements, corrections, updates, etc.

y the third digit is incremented when editorial only changes have been incorporated into the report.

---

# 1 Scope

This technical report describes examples of channel coding and multiplexing for physical channels of FDD mode and TDD mode.

---

# 2 References

The following documents contain provisions which, through reference in this text, constitute provisions of the present document.

- [1] 3GPP TS 25.211: "Physical channels and mapping of transport channels onto physical channels (FDD)"
  - [2] 3GPP TS 25.212: "Multiplexing and channel coding (FDD)"
  - [3] 3GPP TS 25.213: "Spreading and modulation (FDD)"
  - [4] 3GPP TS 25.214: "Physical layer procedures (FDD)"
  - [5] 3GPP TS 25.215: "Physical layer – Measurements (FDD)"
  - [6] 3GPP TS 25.221: "Physical channels and mapping of transport channels onto physical channels (TDD)"
  - [7] 3GPP TS 25.222: "Multiplexing and channel coding (TDD)"
  - [8] 3GPP TS 25.223: "Spreading and modulation (TDD)"
  - [9] 3GPP TS 25.224: "Physical layer procedures (TDD)"
  - [10] 3GPP TS 25.225: "Physical layer – Measurements (TDD)"
- 

# 3 Definitions, symbols and abbreviations

## 3.1 Definitions

For the purposes of the present document, the [following] terms and definitions [given in ... and the following] apply.

**<defined term>**: <definition>.

**example**: text used to clarify abstract rules by applying them literally.

## 3.2 Symbols

For the purposes of the present document, the following symbols apply:

<symbol>      <Explanation>

## 3.3 Abbreviations

For the purposes of the present document, the following abbreviations apply:

<ACRONYM> <Explanation>

BCH	Broadcast Channel
CC	Convolutional coding
CCPCH	Common Control Physical Channel
CRC	Cyclic Redundancy Code
DCH	Dedicated Channel
DCCH	Dedicated Control Channel
DL	Downlink
DPCH	Dedicated Physical Channel
DPCCCH	Dedicated Physical Control Channel
DPDCH	Dedicated Physical Data Channel
FACH	Forward Access Channel

FDD	Frequency Division Duplex
MA	Midamble
Mcps	Mega Chip Per Second
PCCPCH	Primary Common Control Physical Channel
PCH	Paging Channel
PRACH	Physical Random Access Channel
RACH	Random Access Channel
SF	Spreading Factor
SCCPCH	Secondary Common Control Physical Channel
TDD	Time Division Duplex
TFCI	Transport Format Combination Indicator
TPC	Transmit Power Control
TrBk	Transport Block
TrCh	Transport Channel
TTI	Transmission Time Interval
UL	Uplink

## 4 Channel coding and multiplexing examples

Following examples of channel coding and multiplexing is according to reference [2] and [7]. If there are any contradictions between following examples and the references, this technical report should be corrected according to the references unless it is clear that the contradiction comes from error in the references.

Number and variables in following figures show the number of bits in corresponding fields.

### 4.1 FDD mode

#### 4.1.1 Downlink

##### 4.1.1.1 BCH

**Table 1: Parameters for BCH**

Transport block size	246
CRC	16 bits
Coding	CC, coding rate = 1/2
TTI	20 ms
The number of codes	1
SF	256

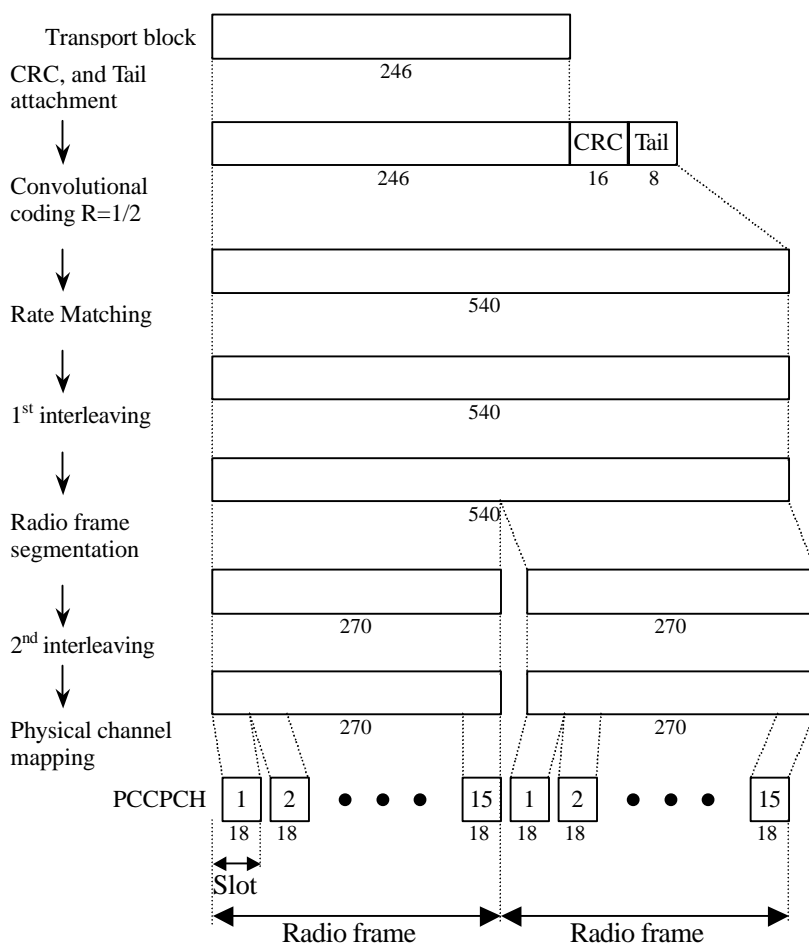

**Figure 1: Channel coding for BCH**



4.1.1.2 Example for PCH and FACH

Table 2: Parameter examples for PCH and FACH

Coding	CC, coding rate = 1/2
TTI	10 ms
The numbers of codes	1

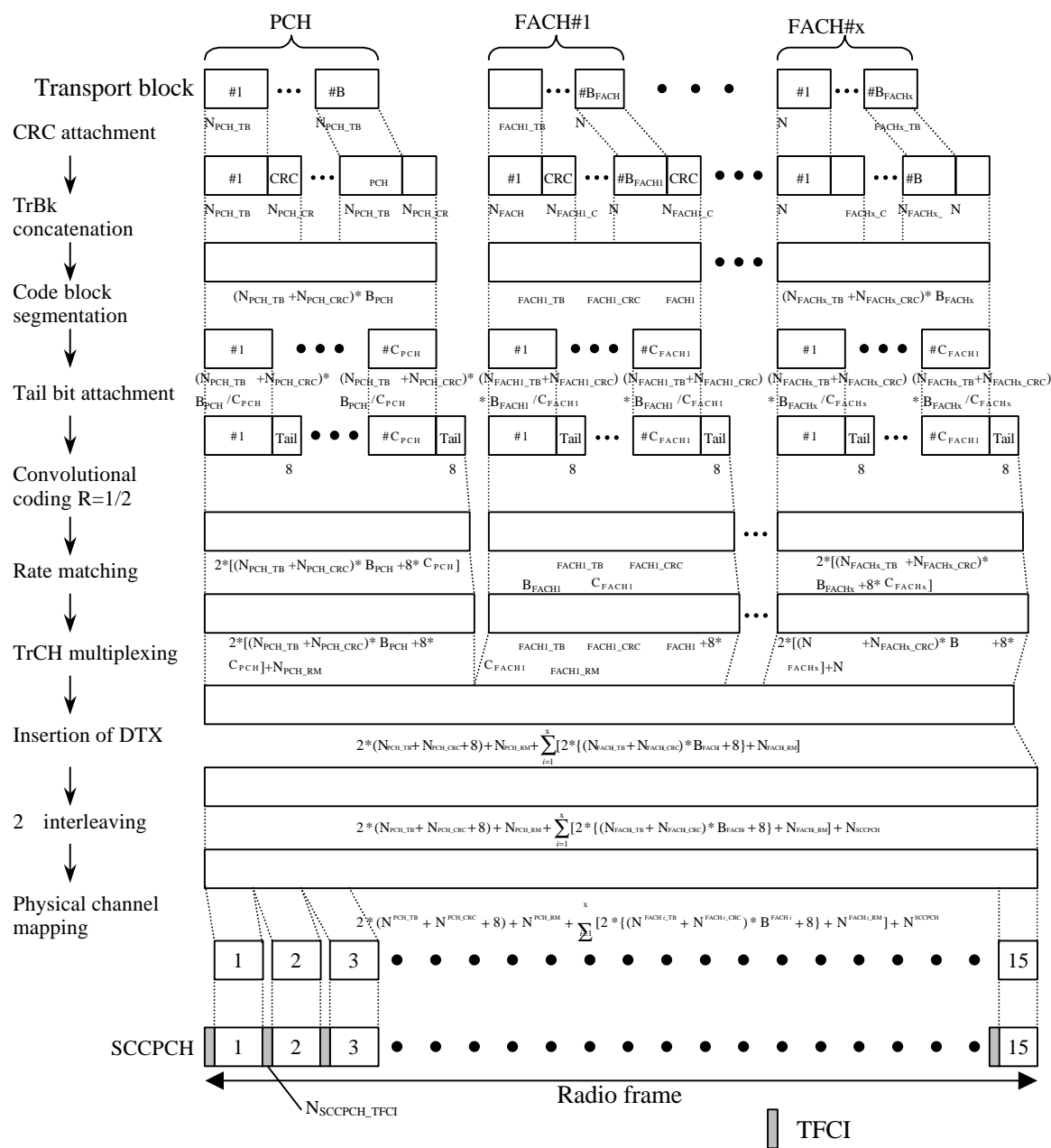

Figure 2: Channel coding and multiplexing example for PCH and FACH

4.1.1.3 Example for DCH

4.1.1.3.1 DCH-> Radio frame segmentation

4.1.1.3.1.1 Example for 4.1 kbps data

<Note: This example can be applied to DCCH.>

**Table 3: Parameter examples for 4.1 kbps data**

Transport block size	164 bits
Transport block set size	164 bits
CRC	16 bits
Coding	CC, coding rate = 1/3
TTI	40 ms

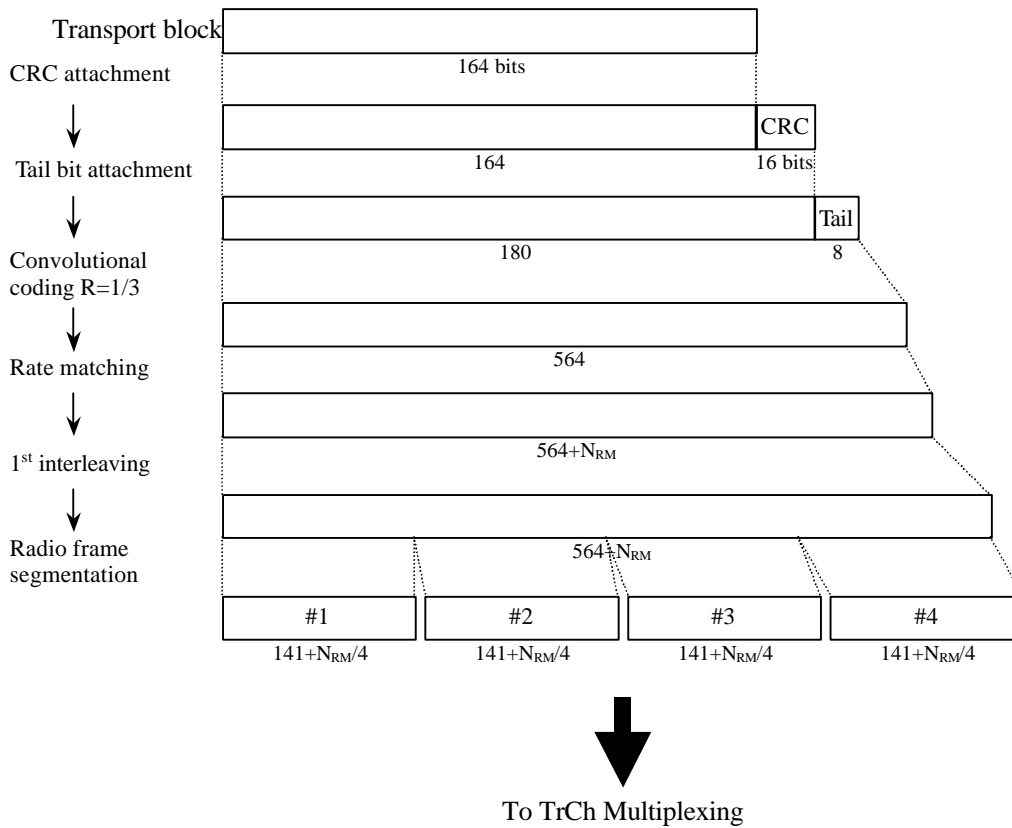

**Figure 3: Channel coding and multiplexing example for 4.1 kbps data**

4.1.1.3.1.2 Example for 12.2 kbps data

<Note: This example can be applied to AMR speech. >

**Table 4: Parameter examples for 12.35 kbps data**

The number of TrChs	3
Transport block size	81, 103, and 60 bits
CRC	12 bits (attached only to TrCh#1)
Coding	CC, coding rate = 1/3 for TrCh#1, 2 coding rate = 1/2 for TrCh#3
TTI	20 ms

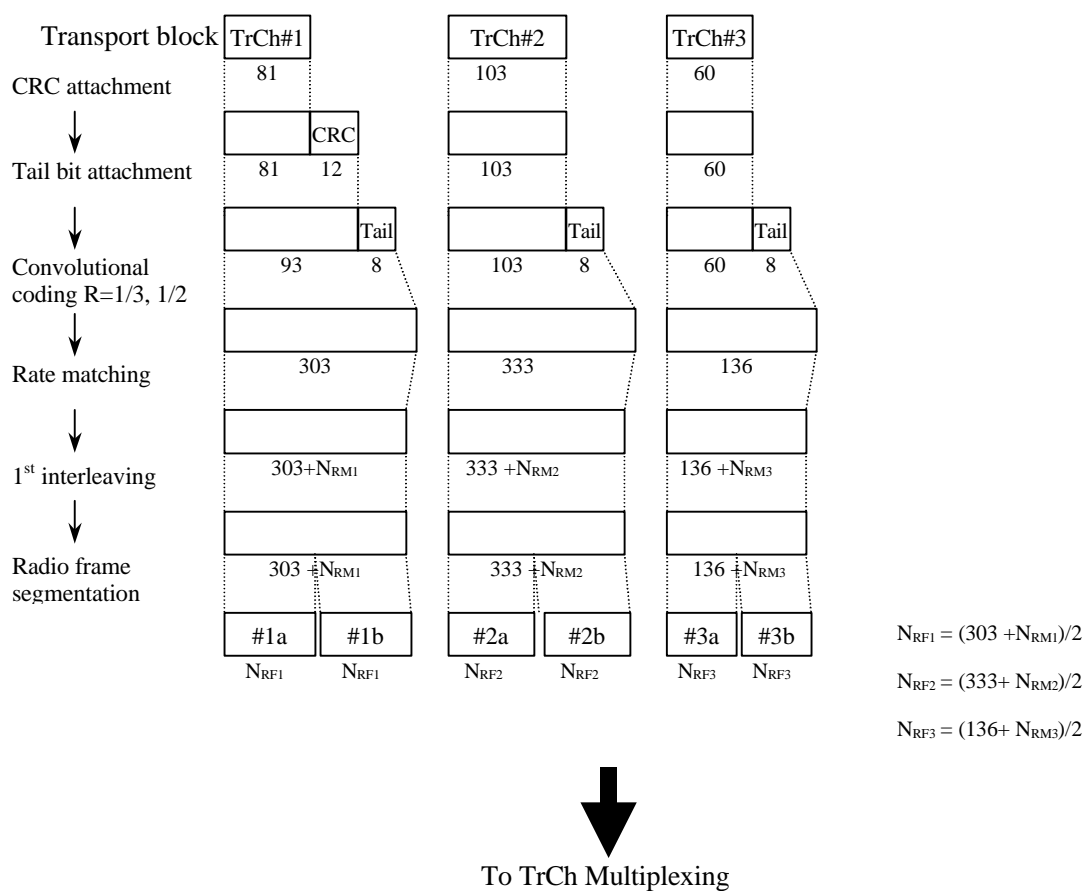
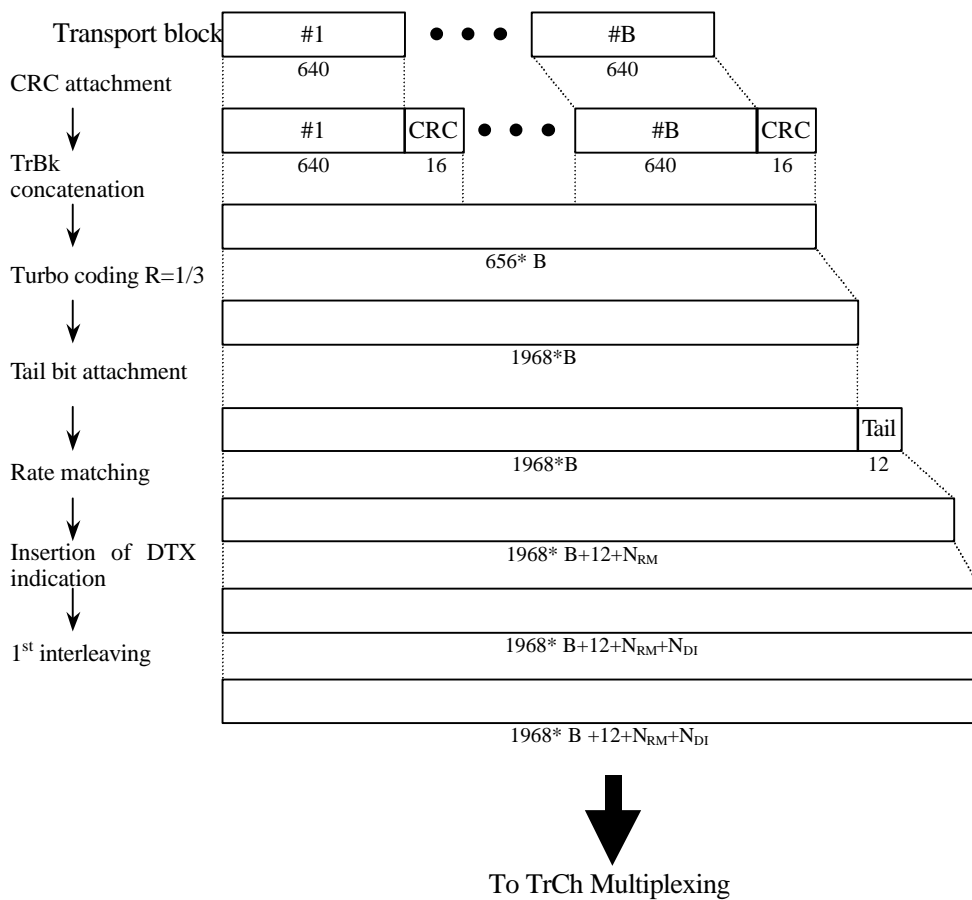

**Figure 4: Channel coding and multiplexing example for 12.2 kbps data**

4.1.1.3.1.3 Example for 64/128/384 kbps packet data

**Table 5: Parameters for 64/128/384 kbps packet data**

The number of TrChs	1	
Transport block size	640 bits	
Transport block Size size	64 kbps	640*B bits (B=0, 1)
	128 kbps	640*B bits (B=0, 1, 2)
	384 kbps	640*B bits (B=0, 1, 2, ..., 6)
CRC	16 bits	
Coding	Turbo coding, coding rate = 1/3	
TTI	10 ms	



**Figure 5: Channel coding and multiplexing example for 64/128/384 kbps packet data**

4.1.1.3.1.4 Example for 64 kbps data

<Note: This example can be applied to ISDN service.>

**Table 6: Parameters for 64 kbps data**

The number of TrChs	1
Transport block size	640 bits
Transport block set size	4*640 bits
CRC	16 bits
Coding	Turbo coding, coding rate = 1/3
TTI	40 ms

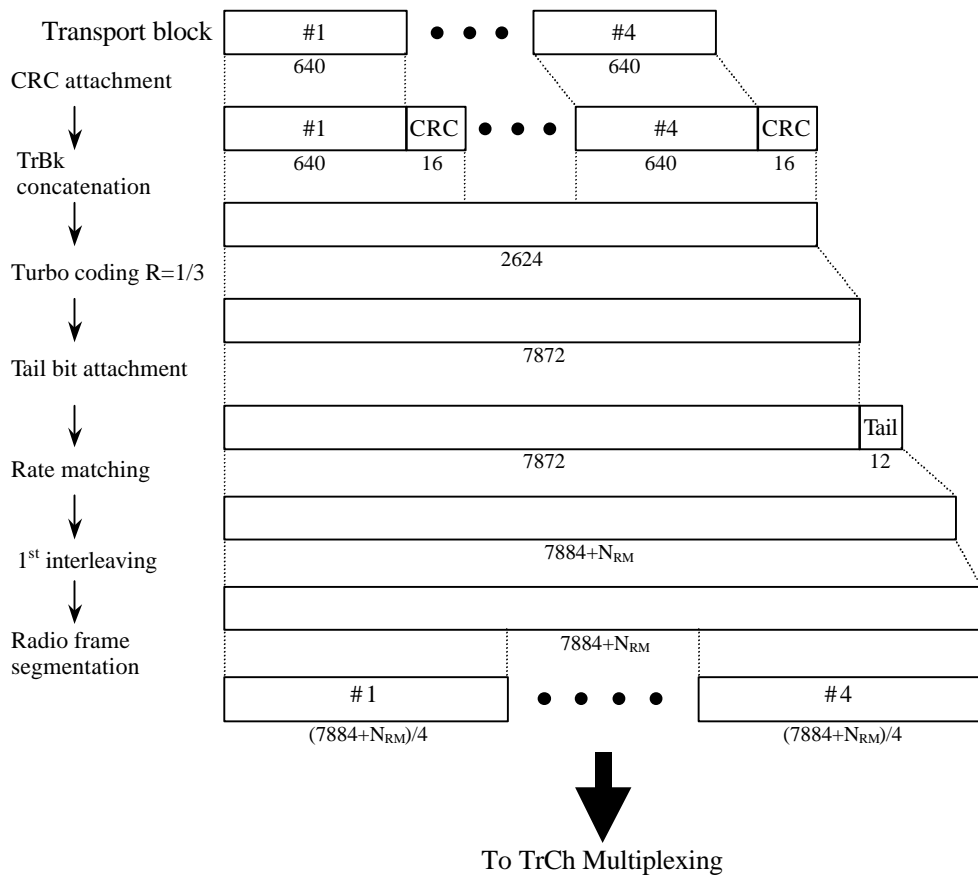

**Figure 6: Channel coding and multiplexing example for 64 kbps data**

4.1.1.3.2 TrCh multiplexing -> Physical channel mapping

4.1.1.3.2.1 Example for Stand-alone mapping of 4.1 kbps data

<Note: This example can be applied to Stand-alone mapping of DCCH.>

Table 7 shows example of physical channel parameters for stand-alone mapping of 4.1 kbps data.

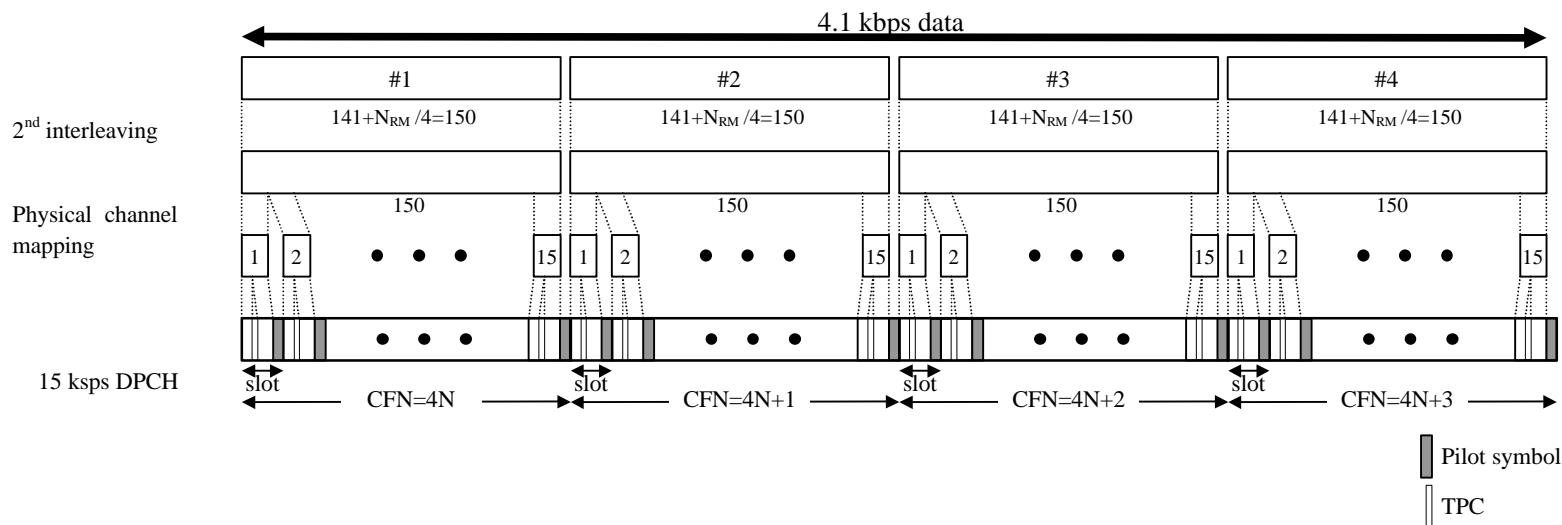

Figure 7: Channel coding and multiplexing example for stand-alone mapping of 4.1 kbps data

Table 7: Physical channel parameters for stand-alone mapping of 4.1 kbps data

Symbol rate (ksps)	$N_{pilot}$ (bits)	$N_{TFCI}$ (bits)	$N_{TPC}$ (bits)	$N_{data1}$ (bits)	$N_{data2}$ (bits)
15	8	0	2	2	8

4.1.1.3.2.2 Example for multiplexing of 12.2 kbps data and 4.1 kbps data

<Note: This example can be applied to multiplexing AMR speech and DCCH.>

Table 8 shows example of physical channel parameters for multiplexing of 12.2 kbps data and 4.1 kbps data.

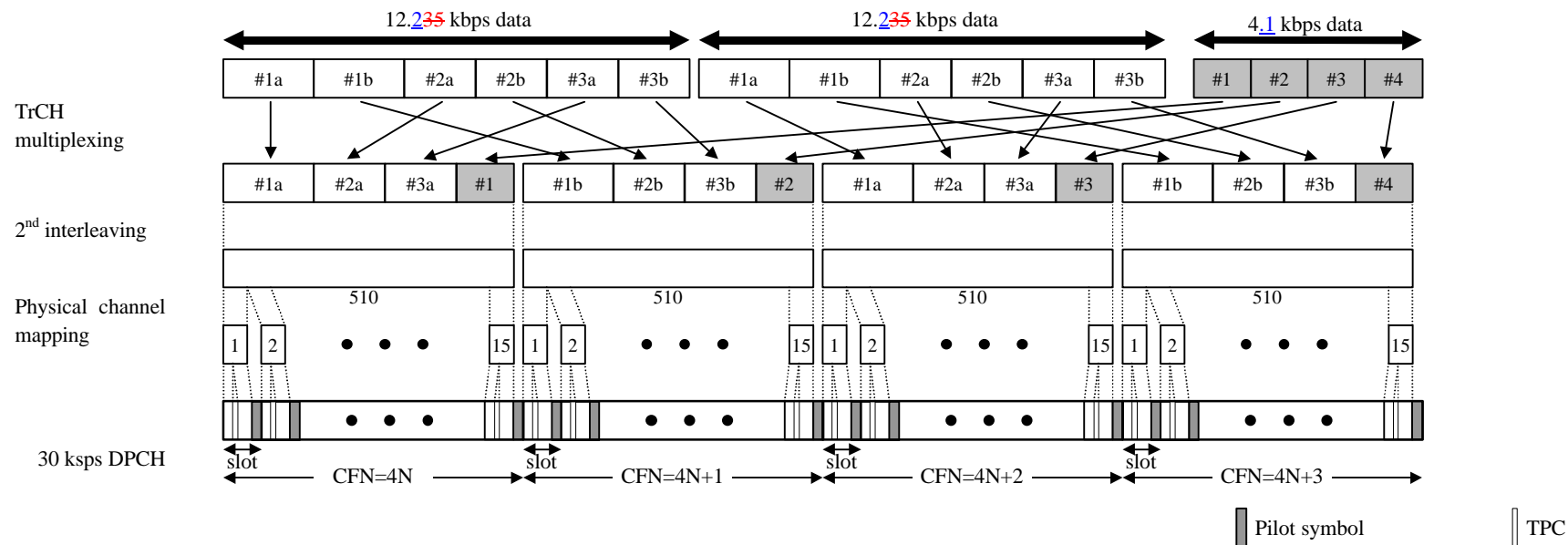

Figure 8: Channel coding and multiplexing example for multiplexing of 12.2 kbps data and 4.1 kbps data

Table 8: Physical channel parameters for multiplexing of 12.2 kbps data and 4.1 kbps data

Symbol rate (ksps)	N <sub>pilot</sub> (bits)	N <sub>TFCI</sub> (bits)	N <sub>TPC</sub> (bits)	N <sub>data1</sub> (bits)	N <sub>data2</sub> (bits)
30	4	0	2	6	28

4.1.1.3.2.3 Example for multiplexing of 64/128/384 kbps packet data and 4.1 kbps data

<Note: This example can be applied to multiplexing 64/128/384 kbps packet data and DCCH.>

Table 9 shows example of physical channel parameters for multiplexing of 64/128/384 kbps packet data and 4.1 kbps data.

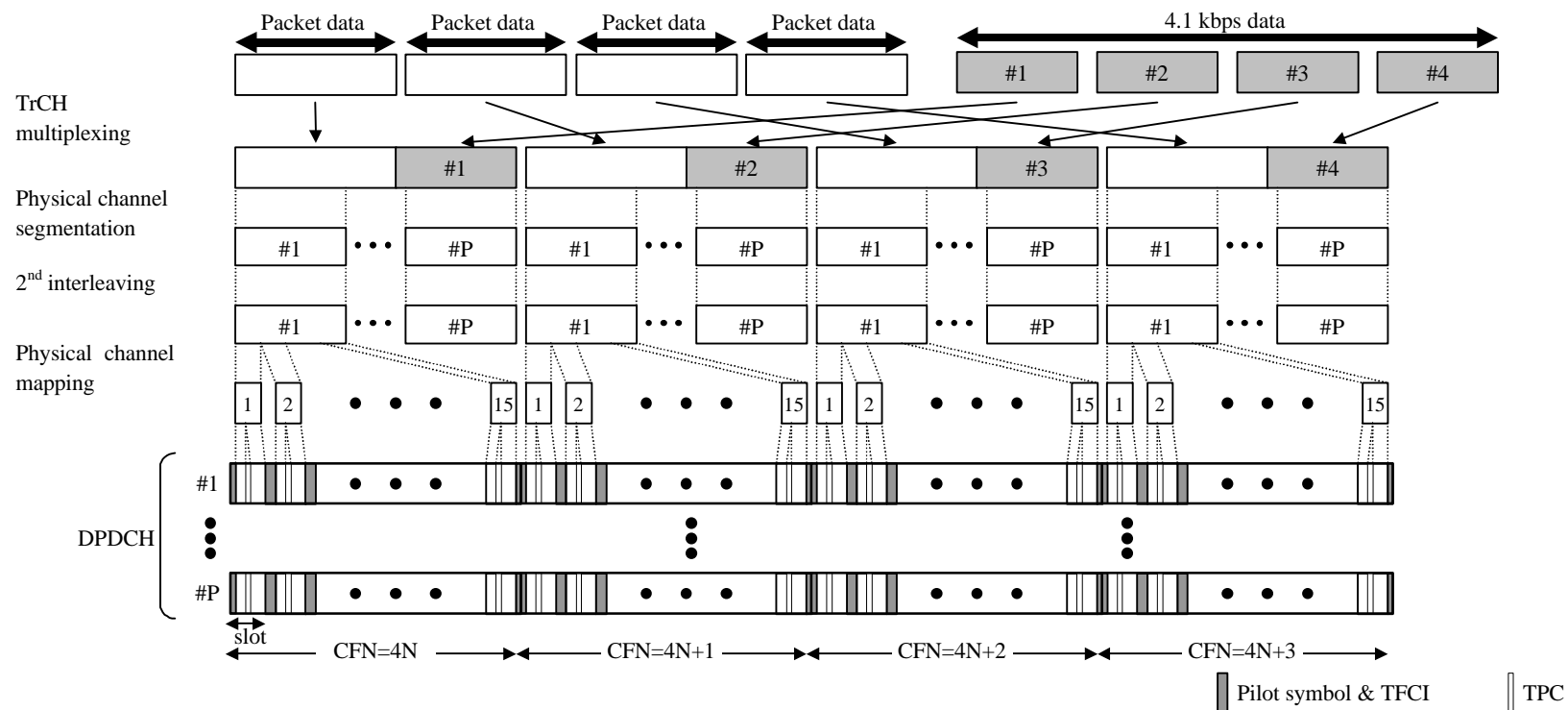

Figure 9: Channel coding and multiplexing example for multiplexing of 64/128/384 kbps packet data and 4.1 kbps data

Table 9: Physical channel parameters for multiplexing of 64/128/384 kbps packet data and 4.1 kbps data

Data rate (kbps)	Symbol rate (ksps)	No. of physical channel: P	$N_{pilot}$ (bits)	$N_{TFCI}$ (bits)	$N_{TPC}$ (bits)	$N_{data1}$ (bits)	$N_{data2}$ (bits)
------------------	--------------------	----------------------------	--------------------	-------------------	------------------	--------------------	--------------------



64	120	1	8	8	4	4	56
128	240	1	16	8	8	48	240
384	240	3	16	8	8	48	240

4.1.1.3.2.4 Example for multiplexing of 64 kbps data and 4.1 kbps data

<Note: This example can be applied to multiplexing ISDNs data and DCCH.>

Table 10 shows example of physical channel parameters for multiplexing of 64 kbps data and 4.1 kbps data.

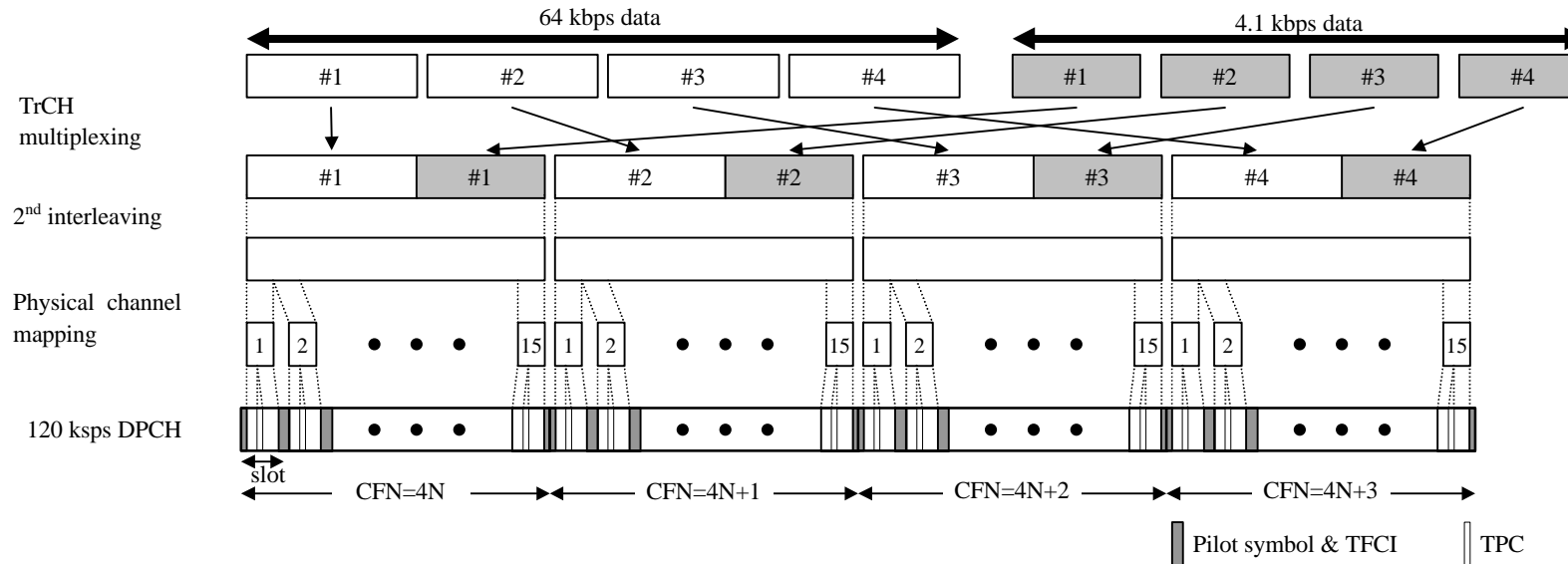

Figure 10: Channel coding and multiplexing example for multiplexing of 64 kbps data and 4.1 kbps data

Table 10: Physical channel parameters for multiplexing of 64 kbps data and 4.1 kbps data

Symbol rate (kps)	No. of physical channel	N <sub>pilot</sub> (bits)	N <sub>TFCI</sub> (bits)	N <sub>TPC</sub> (bits)	N <sub>data1</sub> (bits)	N <sub>data2</sub> (bits)
120	1	8	8*	4	20	120

4.1.2 Uplink

4.1.2.1 Example for RACH

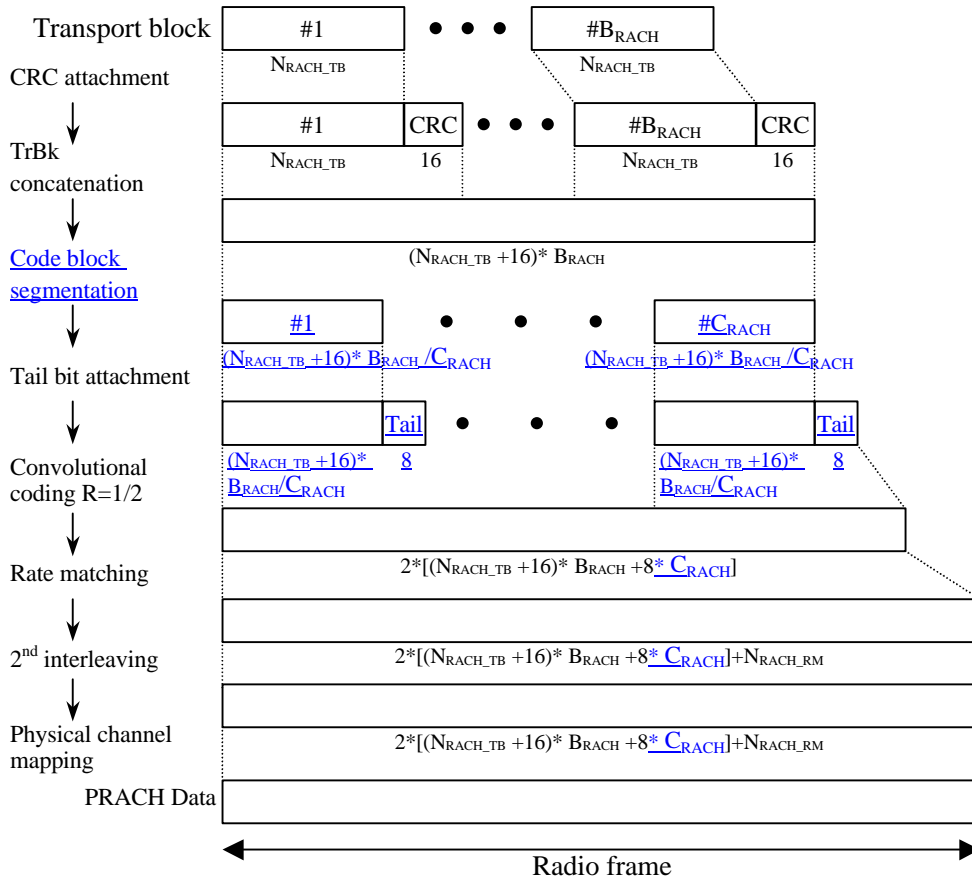

Figure 11: Channel coding and multiplexing example for PRACH

4.1.2.2 Example for DCH

4.1.2.2.1 DCH -> Radio frame segmentation

4.1.2.2.1.1 Example for 4.1 kbps data

<Note: This example can be applied to DCCH.>

**Table 11: Parameter examples for 4.1 kbps data**

Transport block size	164 bits
Transport block set size	164 bits
CRC	16 bits
Coding	CC, coding rate = 1/3
TTI	40 ms

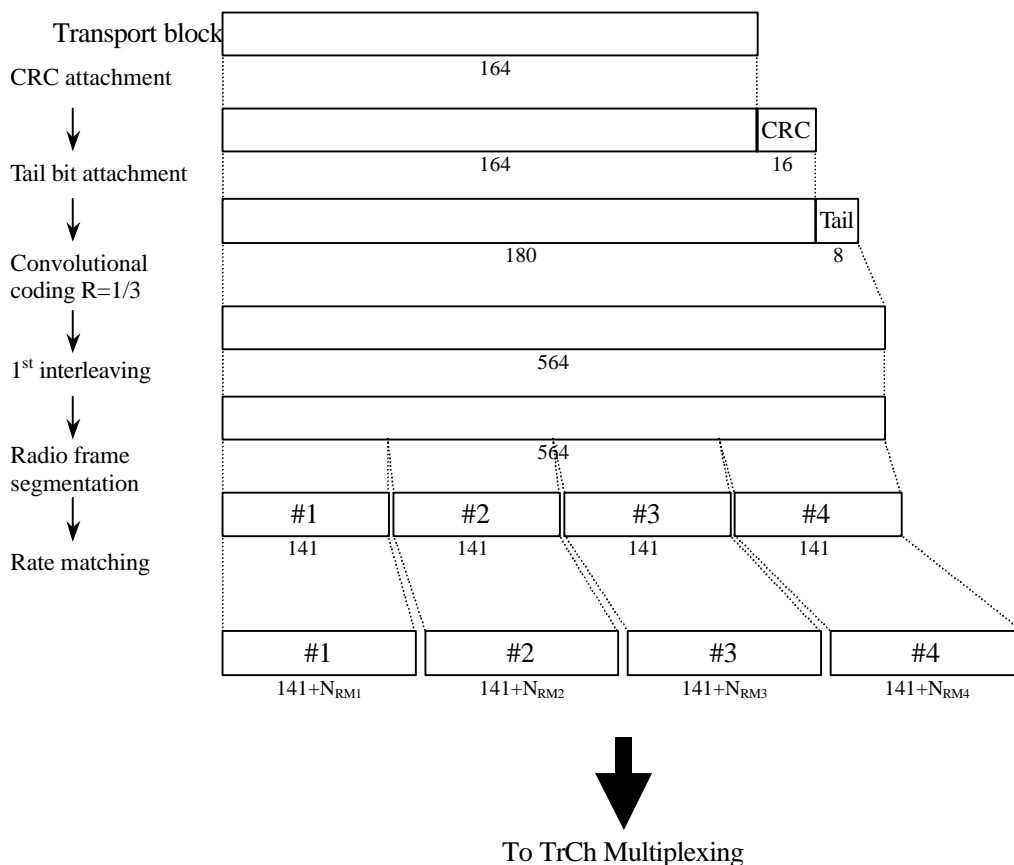

**Figure 12: Channel coding and multiplexing example for 4.1 kbps data**

4.1.2.2.1.2 Example for 12.2 kbps data

<Note: This example can be applied to AMR speech. >

**Table 12: Parameter examples for 12.2 kbps data**

The number of TrChs	3
Transport block size	81, 103, 60, and bits
CRC	12 bits (attached only to TrCh#1)
Coding	CC, coding rate = 1/3 for TrCh#1, 2 coding rate = 1/2 for TrCh#3
TTI	20 ms

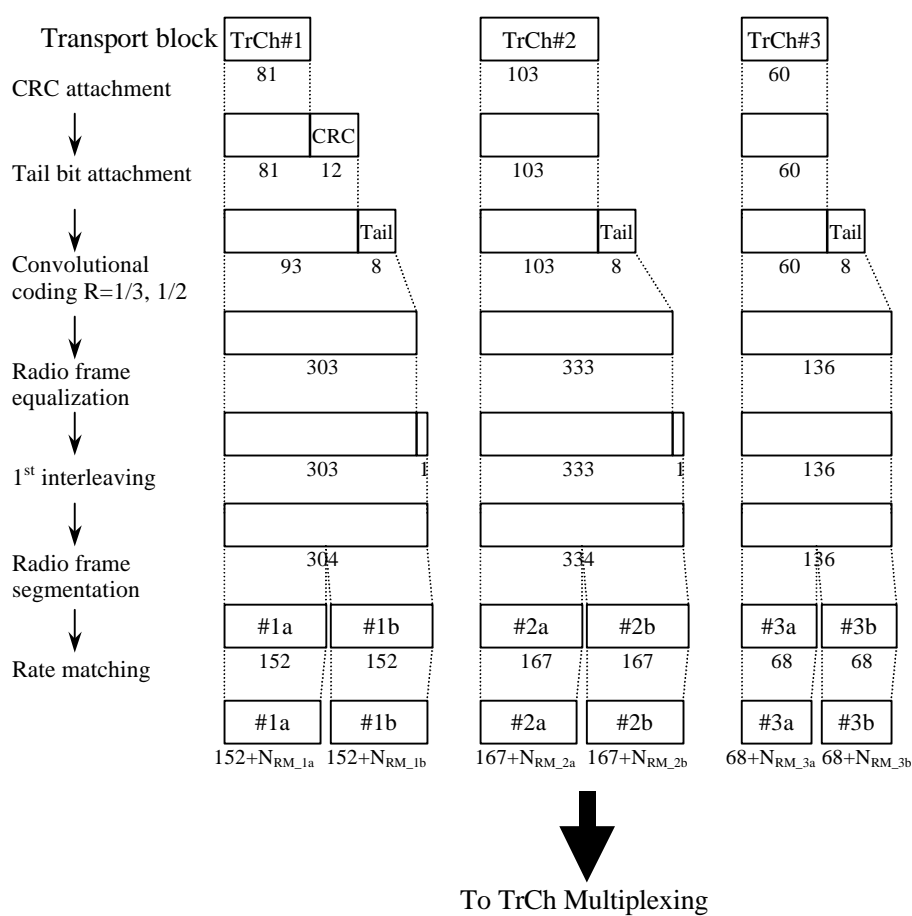
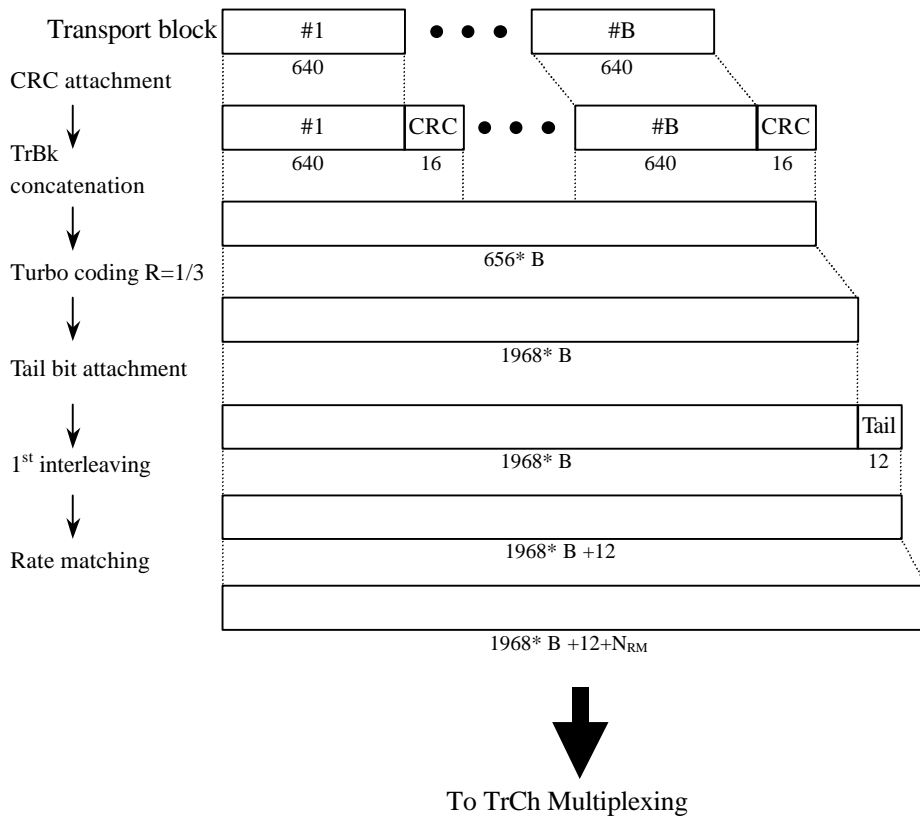

**Figure 13: Channel coding and multiplexing example for 12.2 kbps data**

4.1.2.2.1.3 Example for 64/128/384 kbps packet data

**Table 13: Parameters for 64/128/384 kbps packet data**

The number of TrChs		1
Transport block size		640 bits
Transport block Size size	64 kbps	640*B bits (B=0, 1)
	128 kbps	640*B bits (B=0, 1, 2)
	384 kbps	640*B bits (B=0, 1, 2, ..., 6)
CRC		16 bits
Coding		Turbo coding, coding rate = 1/3
TTI		10 ms



**Figure 14: Channel coding and multiplexing example for 64/128/384 kbps packet data**

4.1.2.2.1.4 Example for 64 kbps data

<Note: This example can be applied to ISDN service.>

**Table 14: Parameters for 64 kbps data**

The number of TrChs	1
Transport block size	640 bits
Transport block set size	4*640 bits
CRC	16 bits
Coding	Turbo coding, coding rate = 1/3
TTI	40 ms

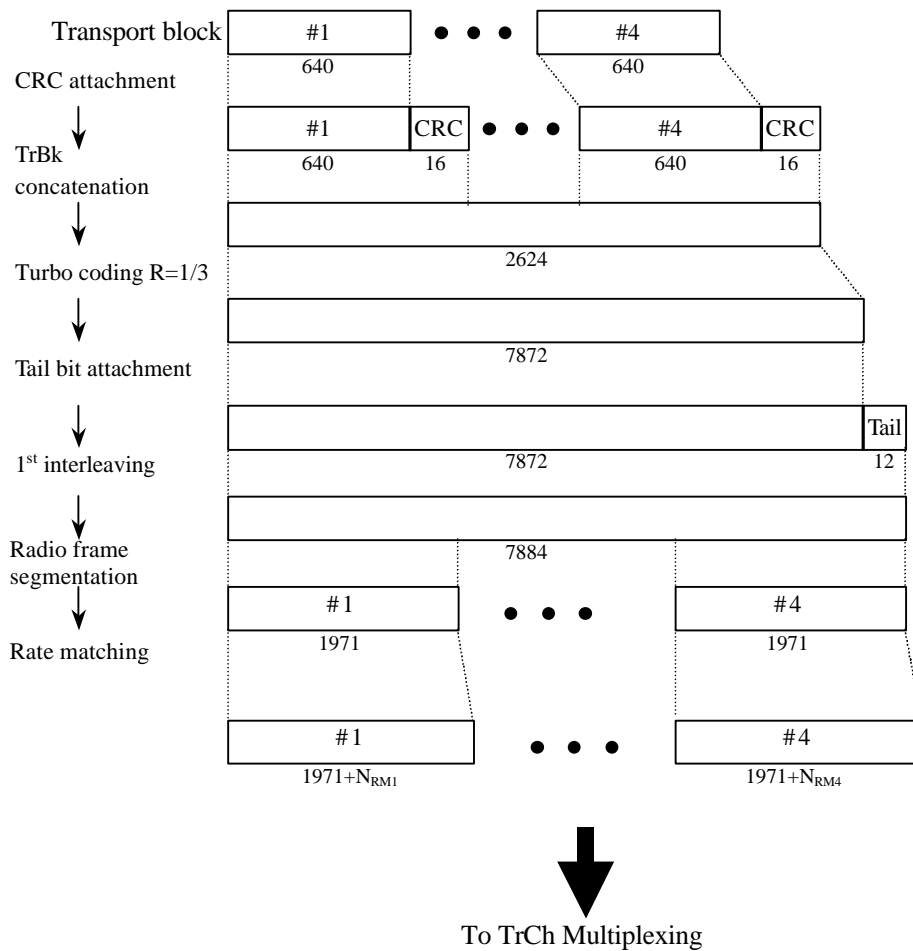
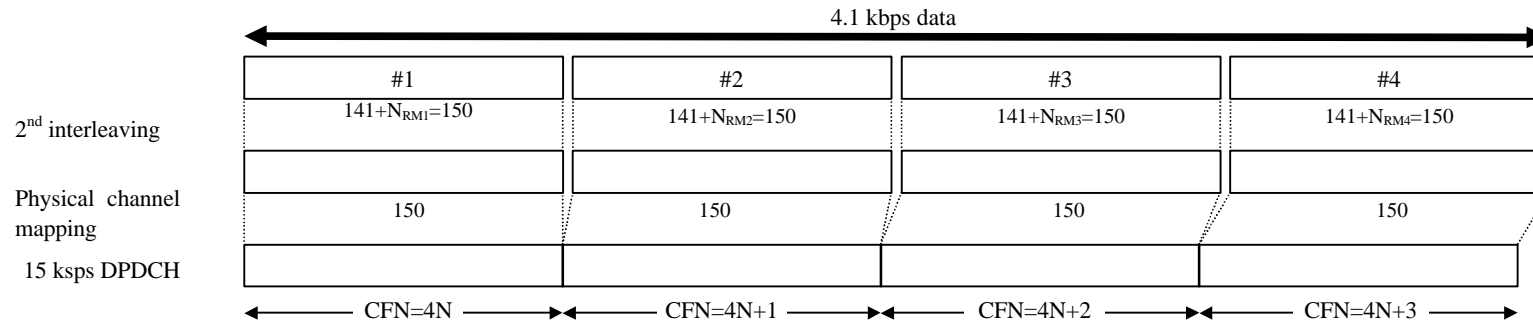

**Figure 15: Channel coding and multiplexing example for 64 kbps data**

4.1.2.2.2 TrCH multiplexing -> Physical channel mapping

4.1.2.2.2.1 Example for Stand-alone mapping of 4.1 kbps data

<Note: This example can be applied to Stand-alone mapping of DCCH.>



**Figure 16: Channel coding and multiplexing example for stand-alone mapping of 4.1 kbps data**



4.1.2.2.2.2 Example for multiplexing of 12.2 kbps data and 4.1 kbps data

<Note: This example can be applied to multiplexing AMR speech and DCCH.>

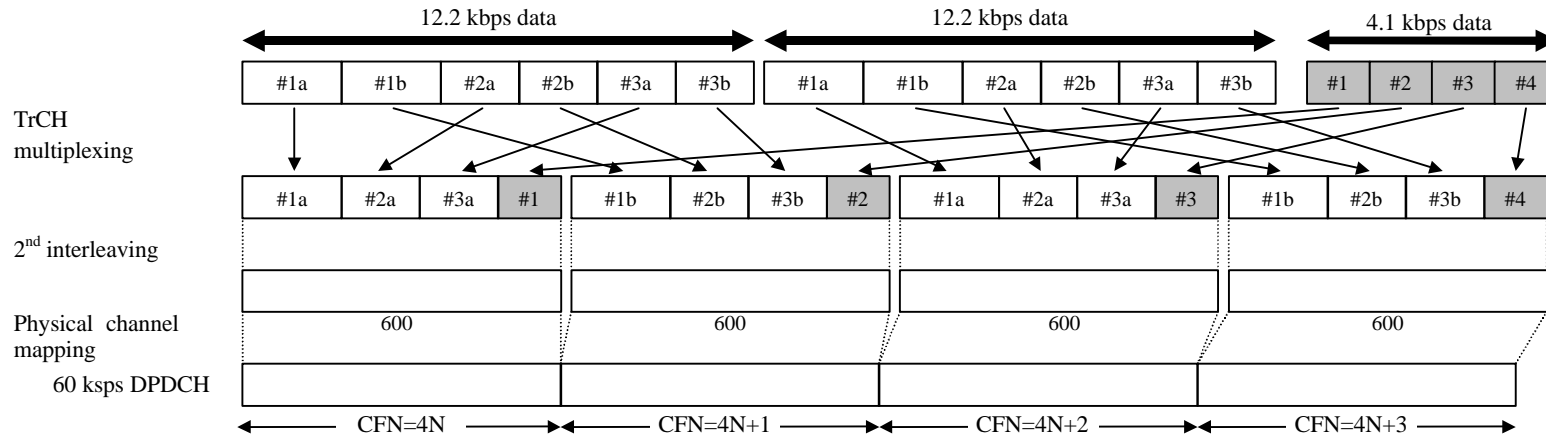

Figure 17: Channel coding and multiplexing example for multiplexing of 12.2 kbps data and 4.1 kbps data

4.1.2.2.3 Example for multiplexing of 64/128/384 kbps packet data and 4.1 kbps data

<Note: This example can be applied to multiplexing 64/128/384 kbps packet data and DCCH.>

Table 15 shows example of physical channel parameters for multiplexing of 64/128/384 kbps packet data and 4.1 kbps data.

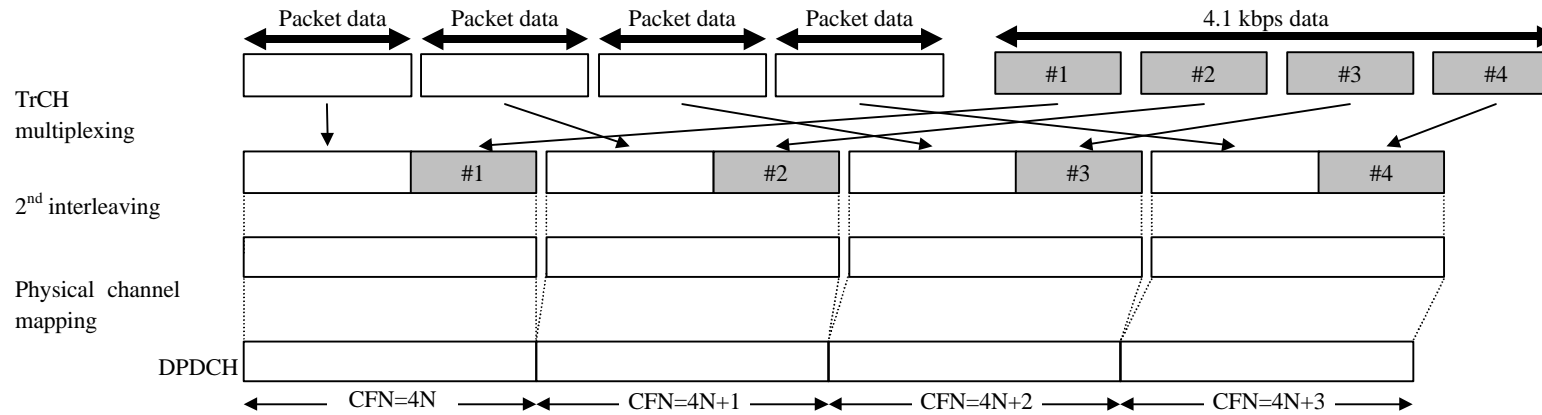

Figure 18: Channel coding and multiplexing example for multiplexing of 64/128/384 kbps packet data and 4.1 kbps data

Table 15: Physical channel parameters for multiplexing of 64/128/384 kbps packet data and 4.1 kbps data

Data rate (kbps)	Symbol rate (ksps)	No. of physical channel
64	240	1
128	480	1
384	960	1

4.1.2.2.2.4 Example for multiplexing of 64 kbps data and 4.1 kbps data

<Note: This example can be applied to multiplexing ISDNs data and DCCH.>

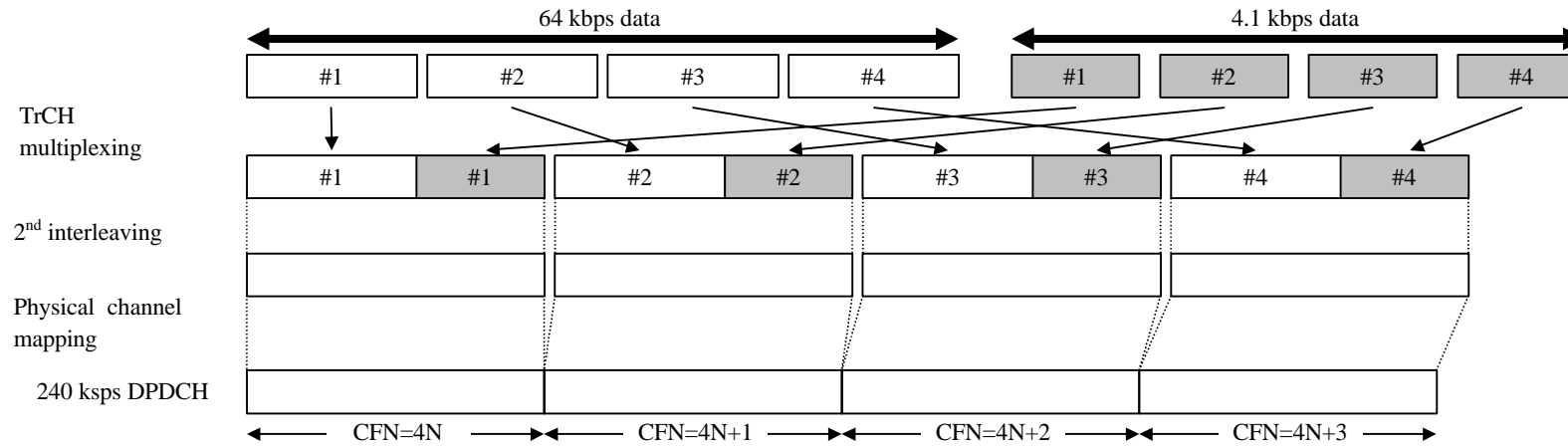

Figure 19: Channel coding and multiplexing example for multiplexing of 64 kbps data and 4.1 kbps data

## 4.2 TDD mode

### 4.2.1 Downlink

#### 4.2.1.1 BCH

**Table 16: Parameters for BCH**

Transport block size	246 bits
CRC	16 bits
Coding	CC, coding rate = 1/2
TTI	20 ms
Midamble	512 chips
RU's allocated	SF=16 x 1 x 1 time slot
Codes and time slots	1 RU
TFCI	0 bit
TPC	0 bit

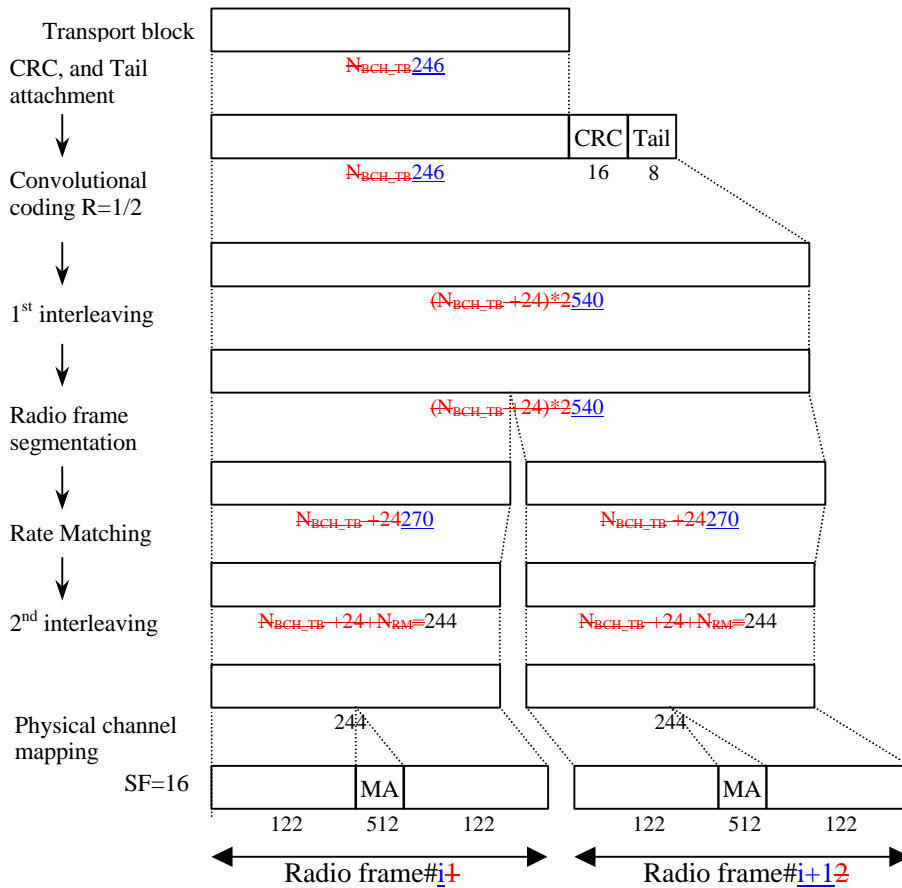

**Figure 20 Channel coding for BCH**

4.2.1.2 Example for PCH

Table 17: Parameters for PCH

CRC	8 bits
Coding	CC, coding rate = 1/2
TTI	20 ms
Midamble	512 chips
Codes and time slots allocated	SF=16 x 1 x 1 time slot 1 RU
TFCI	0 bit
TPC	0 bit

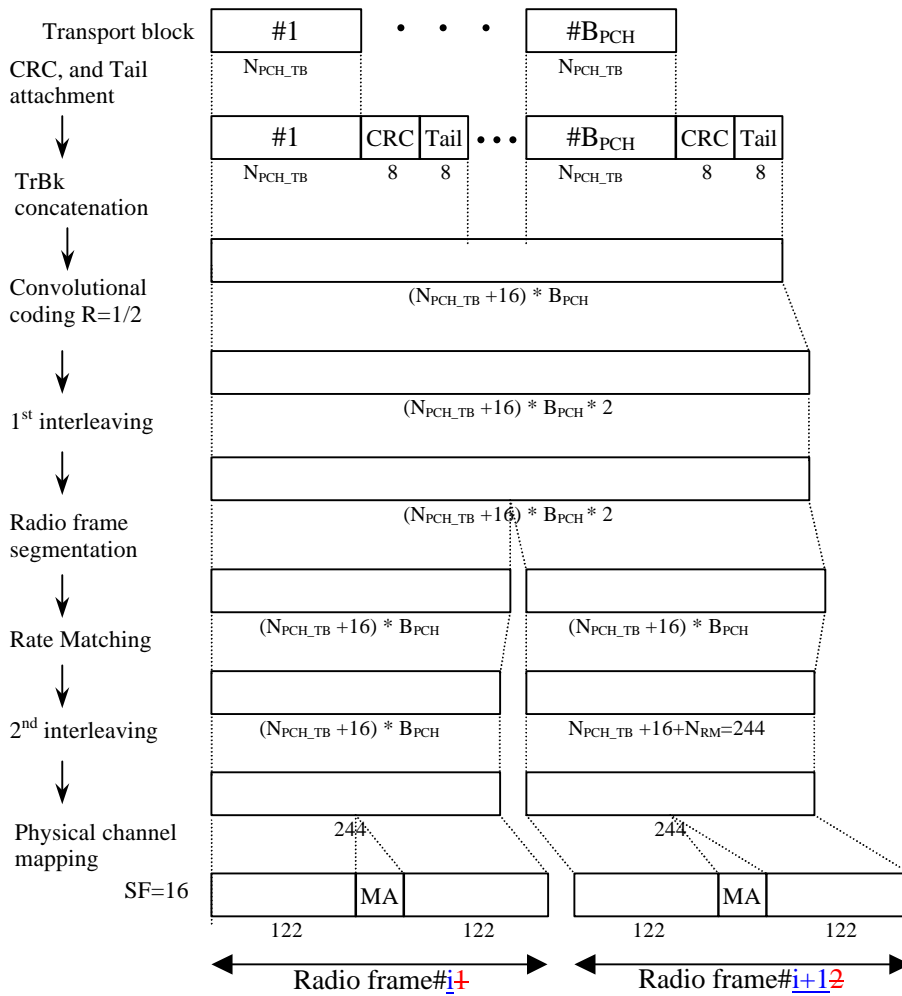

Figure 21: Channel coding and multiplexing example for PCH

4.2.1.3 Example for FACH

Table 18: Parameters for FACH

CRC	8 bits
Coding	CC, coding rate = 1/2
TTI	20 ms
Midamble	512 chips
Codes and time slots allocated	SF=16 x 1 x 1 time slot 1 RU
TFCI	0 bit
TPC	0 bit

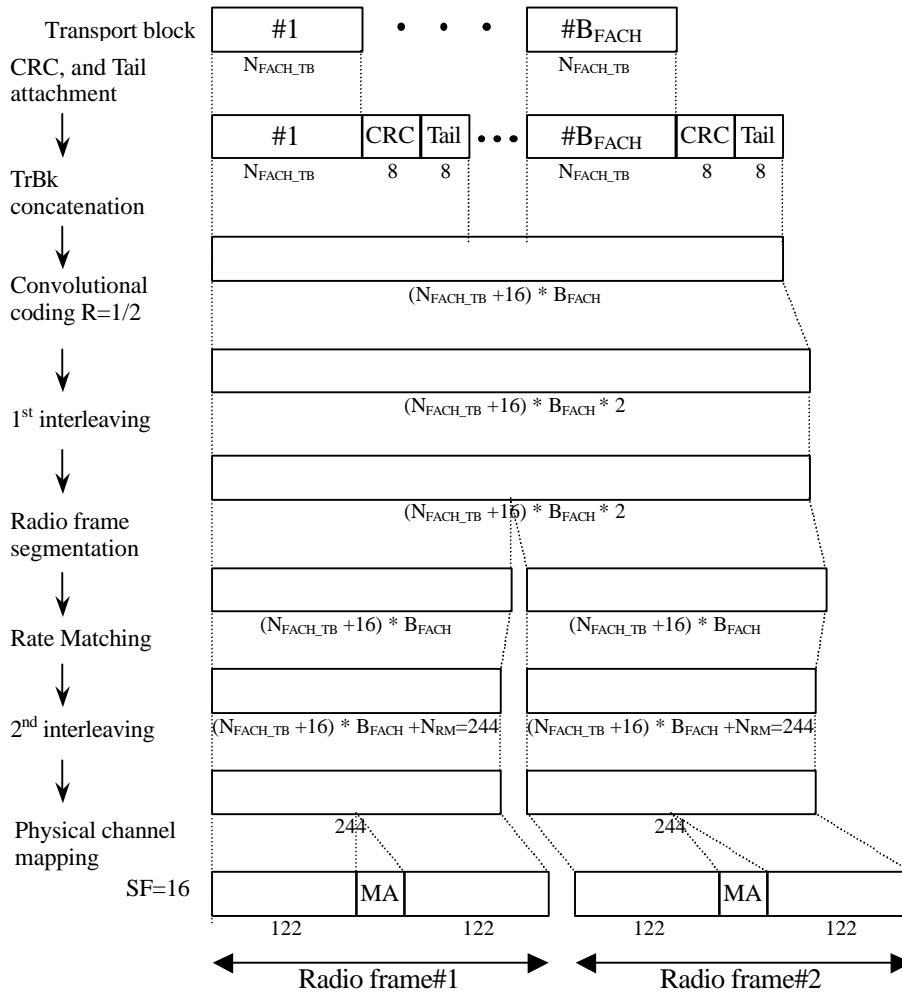

Figure 22: Channel coding and multiplexing example for FACH

4.2.1.4 Example for DCH

4.2.1.4.1 DCH-> Radio frame segmentation

4.2.1.4.1.1 Example for 2.4 kbps data

<Note: This example can be applied to DCCH.>

**Table 19: Parameter examples for 2.4 kbps data**

Transport block size	96 bits
Transport block set size	96 bits
CRC	16 bits
Coding	CC, coding rate = 1/3
TTI	40 ms

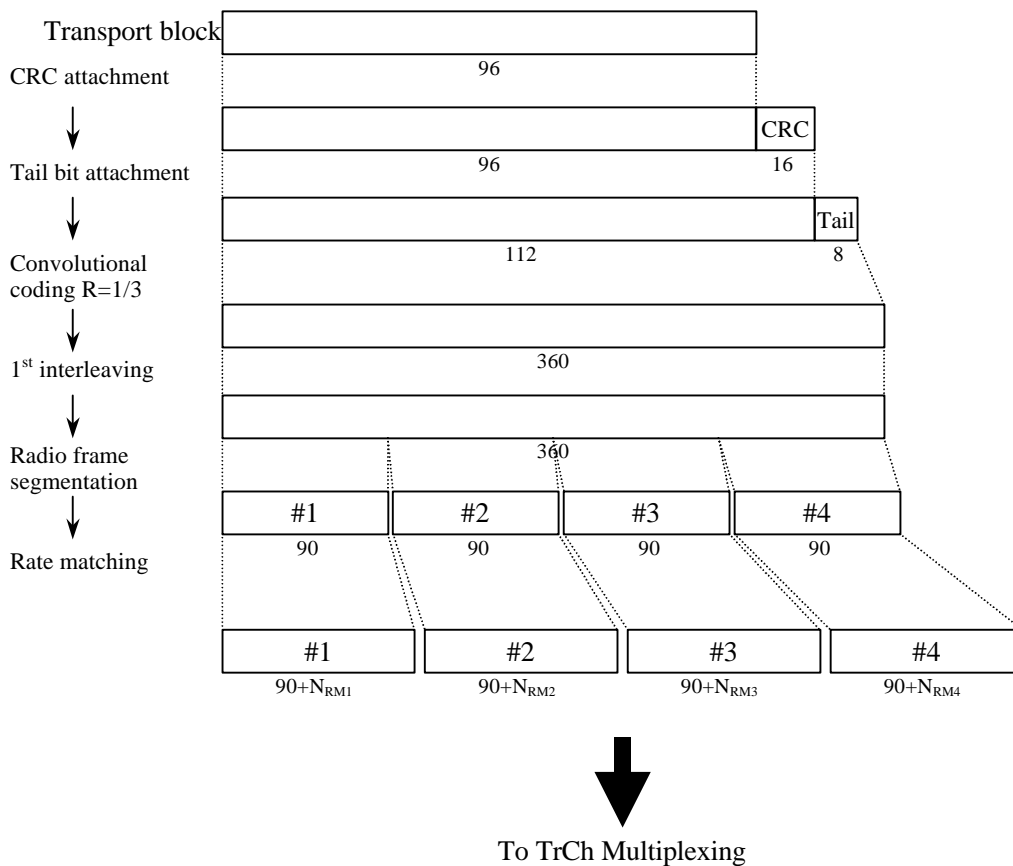

**Figure 23: Channel coding and multiplexing example for 2.4 kbps data**

4.2.1.4.1.2 Example for 12.2 kbps data

<Note: This example can be applied to AMR speech. >

**Table 20: Parameter examples for 12.2 kbps data**

The number of TrChs	3
Transport block size	81, 103, and 60 bits
CRC	12 bits (attached only to TrCh#1)
Coding	CC, coding rate = 1/3 for TrCh#1, 2 coding rate = 1/2 for TrCh#3
TTI	20 ms

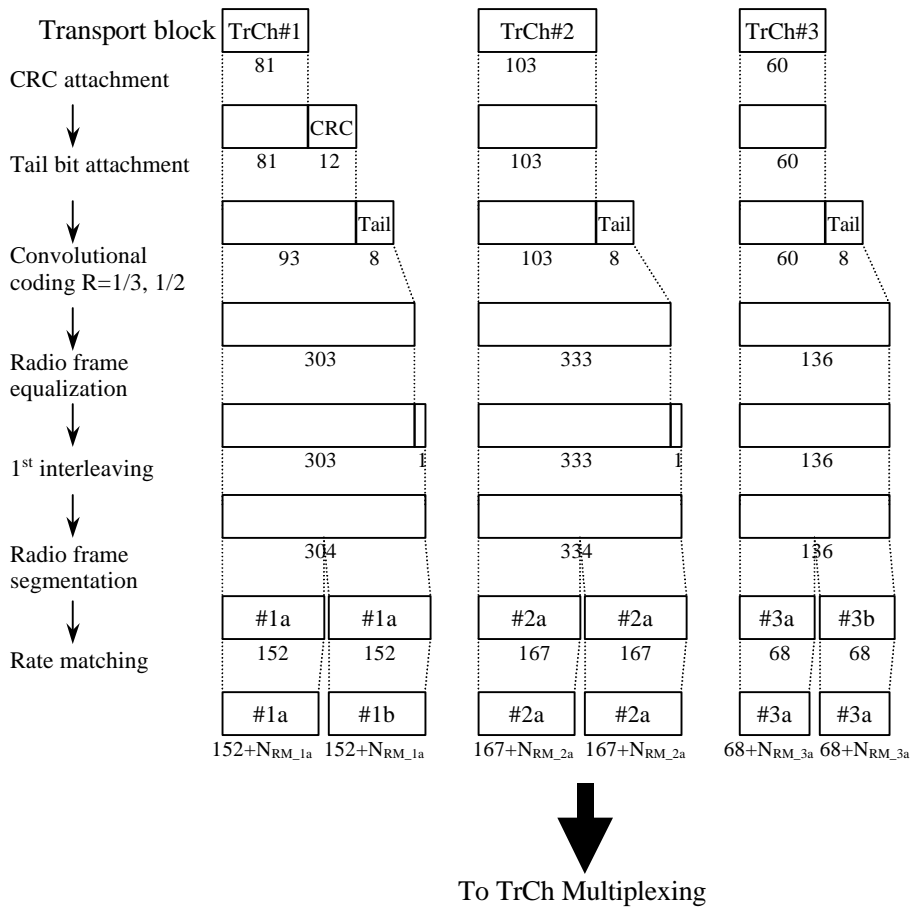

**Figure 24: Channel coding and multiplexing example for 12.2 kbps data**



4.2.1.4.1.3 Example of 64/128/384 kbps packet data

**Table 21: Parameters for 64/128/384 kbps packet data**

The number of TrChs	1	
Transport block Size: S	64 kbps	1280 bits
	128 kbps	2560 bits
	384 kbps	3840 bits
Transport block set size	64 kbps	1280*B bits (B=0, 1)
	128 kbps	2560*B bits (B=0, 1)
	384 kbps	3840*B bits (B=0, 1, 2)
Code block segmentation: C	64 kbps	1
	128 kbps	1
	384 kbps	1 (B=0, 1) or 2 (B=2)
CRC	16 bits	
Coding	Turbo coding, coding rate = 1/3	
TTI	20 ms	

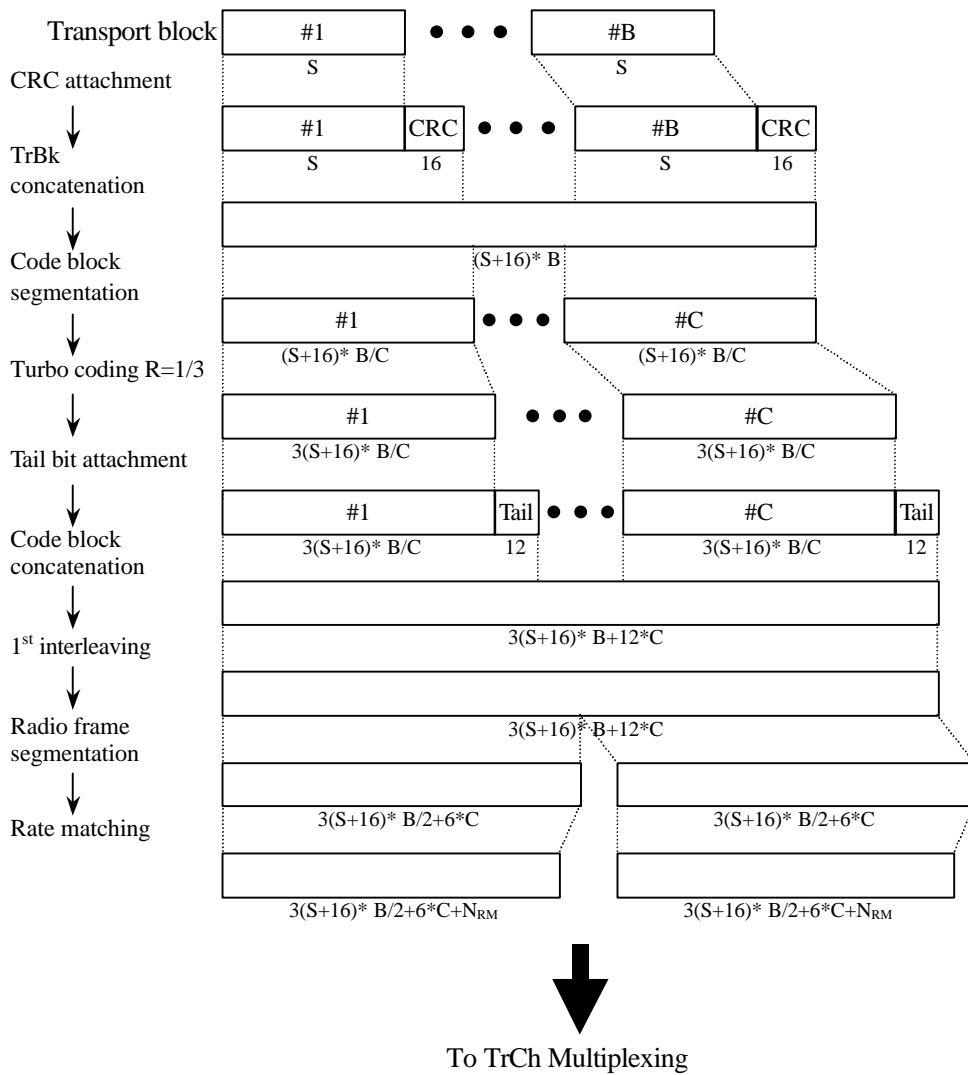

**Figure 25: Channel coding and multiplexing example for 64/128/384 kbps packet data**

4.2.1.4.1.4 Example for 64 kbps data

<Note: This example can be applied to ISDN service.>

**Table 22: Parameters for 64 kbps data**

The number of TrChs	1
Transport block size	1280 bits
Transport block set size	1280 bits
CRC	16 bits
Coding	Turbo coding, coding rate = 1/3
TTI	20 ms

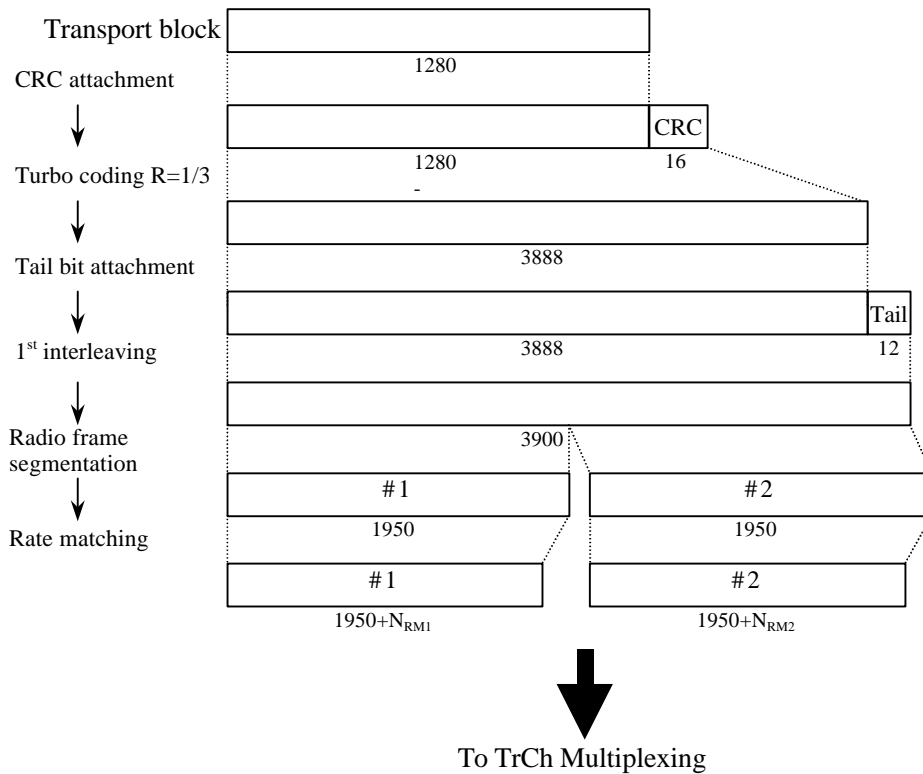

**Figure 26: Channel coding and multiplexing example for 64 kbps data**

4.2.1.4.2 TrCH multiplexing -> Physical channel mapping

4.2.1.4.2.1 Example for Stand-alone mapping of 2.4 kbps data

<Note: This example can be applied to Stand-alone mapping of DCCH.>

Table 23 shows example of physical channel parameters for Stand-alone mapping of 2.4 kbps data.

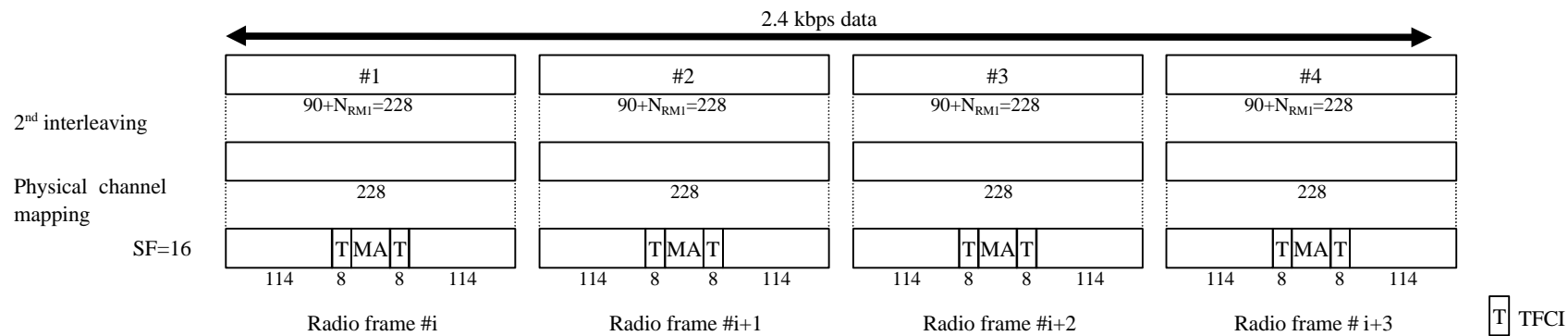

Figure 27: Channel coding and multiplexing example for Stand-alone mapping of 2.4 kbps data

Table 23: Physical channel parameters for Stand-alone mapping of 2.4 kbps data

Midamble	512 chips
Multi-codes and time slots	SF16 x 1 code x 1 time slot
TFCI	16 bits per user
TPC	0 bit

4.2.1.4.2.2 Example for multiplexing of 12.2 kbps data and 2.4 kbps data

<Note: This example can be applied to multiplexing AMR speech and DCCH.>

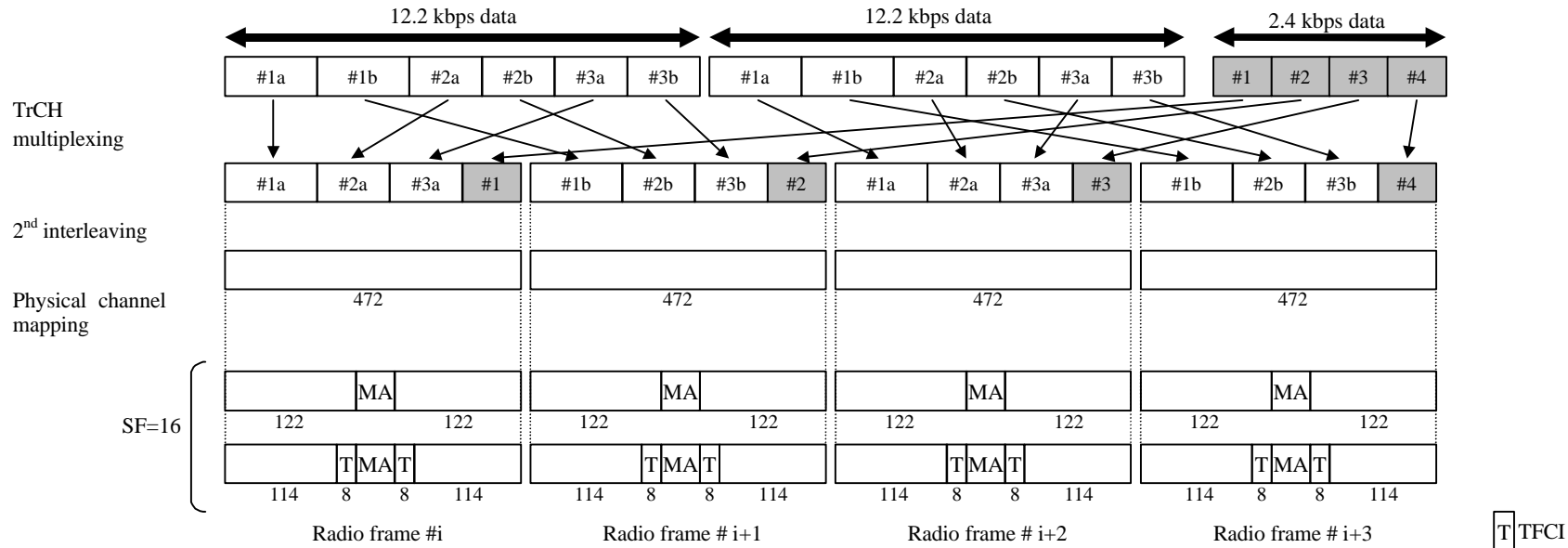

Figure 28: Channel coding and multiplexing example for multiplexing of 12.2 kbps data and 2.4 kbps data

Table 24: Physical channel parameters for multiplexing of 12.2 kbps data and 2.4 kbps data

Midamble	512 chips
Multi-codes and time slots	SF16 x 2 code x 1 time slot
TFCI	16 bits per user
TPC	0 bit

4.2.1.4.2.3 Example for multiplexing of 64/128/384 kbps packet data and 2.4 kbps data

<Note: This example can be applied to multiplexing 64/128/384 kbps packet data and DCCH.>

Table 25 shows example of physical channel parameters for multiplexing of 64/128/384 kbps packet data and 2.4 kbps data.

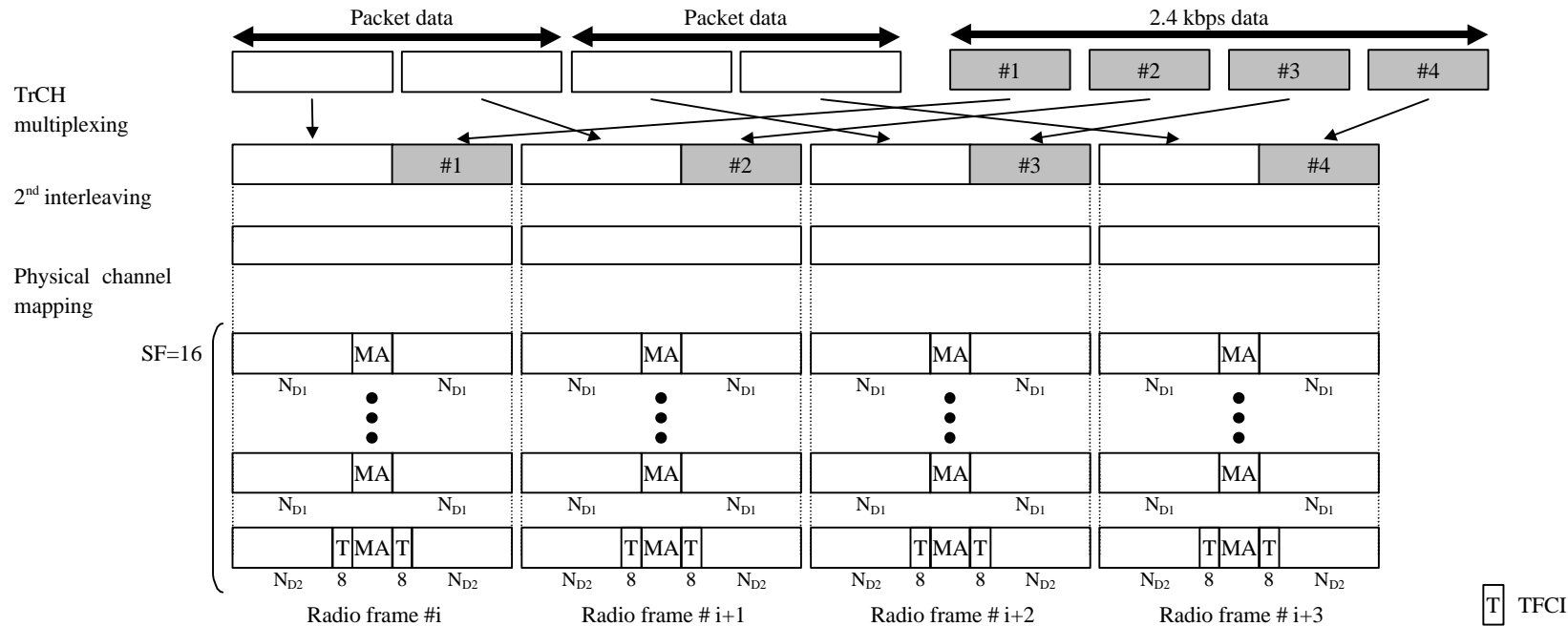

Figure 29: Channel coding and multiplexing example for multiplexing of 64/128/384 kbps packet data and 2.4 kbps data

Table 25: Physical channel parameters for multiplexing of 64/128/384 kbps packet data and 2.4 kbps data

Midamble	64 kbps	512 chips
	128 & 384 kbps	256 chips
N <sub>D1</sub> , N <sub>D2</sub>	64 kbps	122 bits, 114 bits
	128 & 384 kbps	138 bits, 130 bits
Multi-code & time slots	64 kbps	SF16 x 5 codes x 1 time slot
	128 kbps	SF16 x 9 codes x 1 time slot
	384 kbps	SF16 x 8 codes x 3 time slots
TFCI	16 bits per user	
TPC	0 bit	

4.2.1.4.2.4 Example for multiplexing of 64 kbps data and 2.4 kbps data

<Note: This example can be applied to multiplexing ISDNs data and DCCH.>

Table 26 shows example of physical channel parameters for multiplexing of 64/128/384 kbps packet data and 2.4 kbps data.

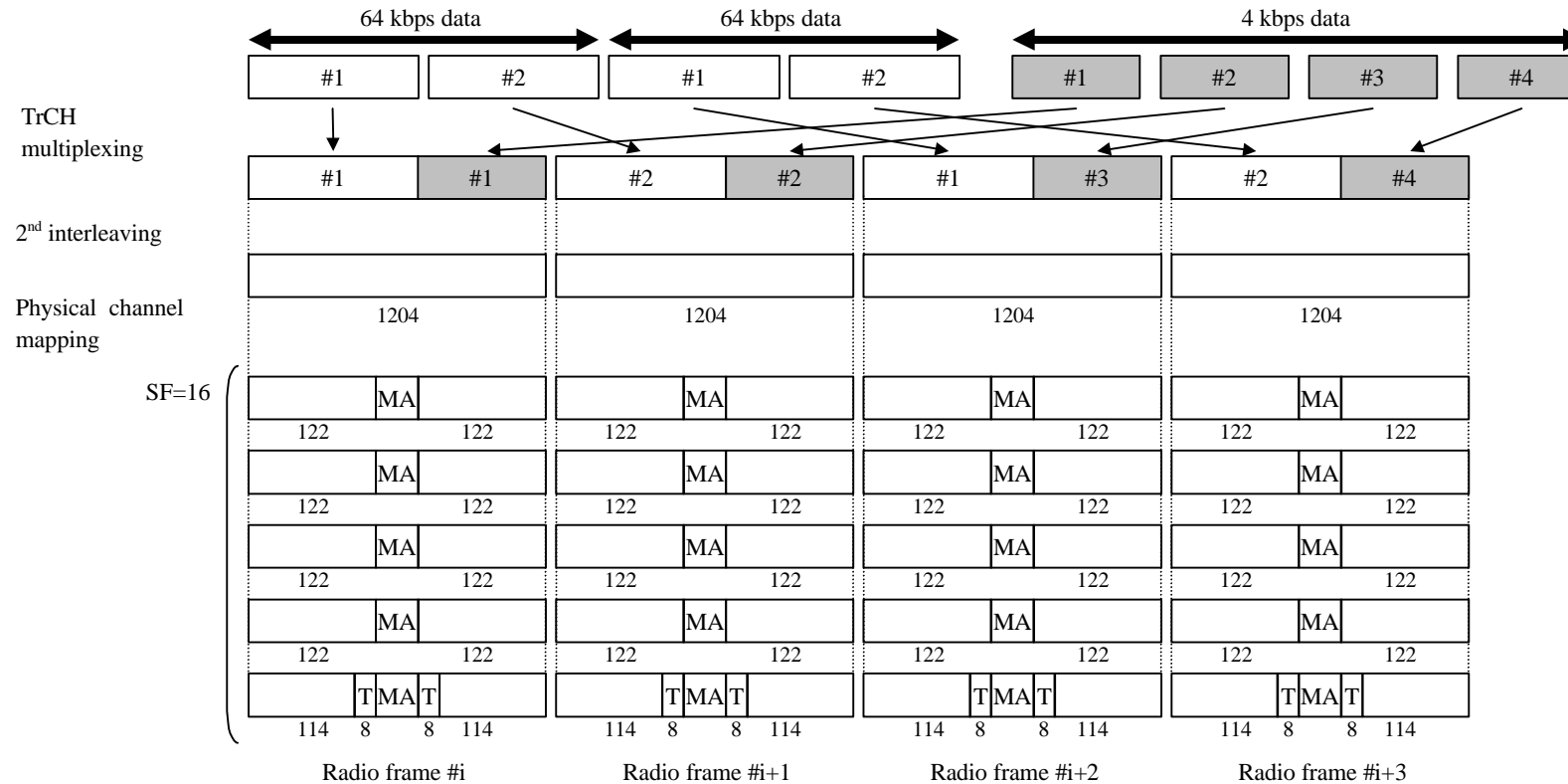

Figure 30: Channel coding and multiplexing example for multiplexing of 64/128/384 kbps packet data and 2.4 kbps data

Table 26: Physical channel parameters for multiplexing of 64/128/384 kbps packet data and 2.4 kbps data

Midamble	512 chips
Multi-code & time slots	SF16 x 5 codes x 1 time slot
TFCI	16 bits per user
TPC	0 bit

4.2.2 Uplink

4.2.2.1 RACH

Table 27: Parameters for RACH

CRC	8 bits
Coding	CC, coding rate = 1/2
TTI	10 ms
Midamble	512 chips
Codes and time slots allocated	SF=16 x 1 x 1 time slot 1 RU
TFCI	0 bit
TPC	0 bit

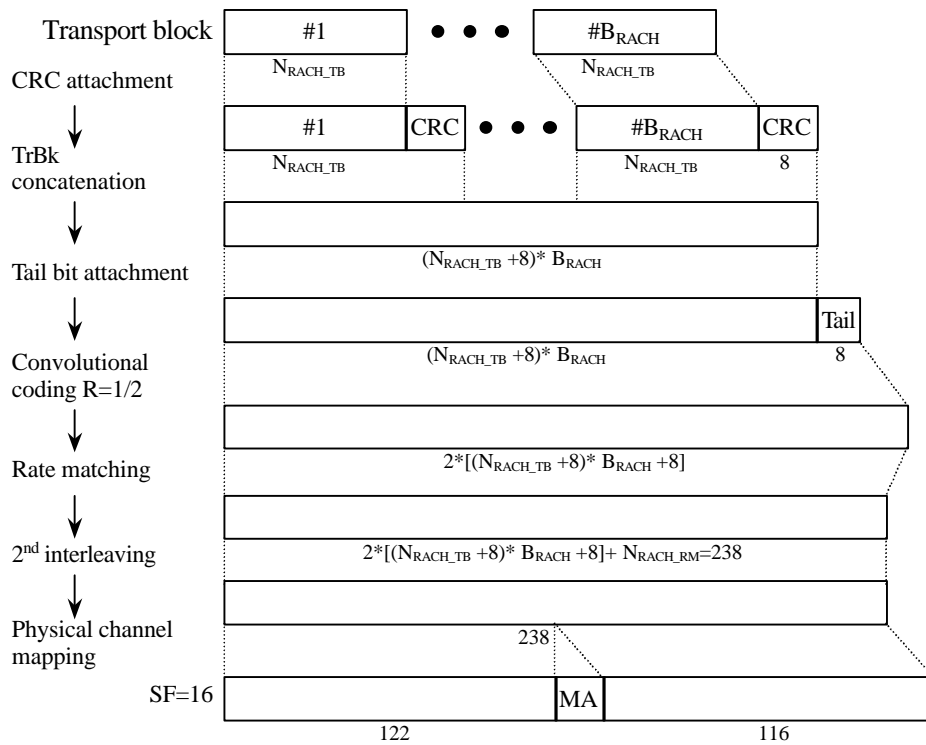

Figure 31: Channel coding and multiplexing example for RACH

#### 4.2.2.2 Example for DCH

##### 4.2.2.2.1 DCH-> Radio frame segmentation

See 4.2.1.4.2.



4.2.2.2.2 TrCH multiplexing -> Physical channel mapping

4.2.2.2.2.1 Example for Stand-alone mapping of 2.4 kbps data

<Note: This example can be applied to Stand-alone mapping of DCCH.>

Table 28 shows example of physical channel parameters for Stand-alone mapping of 2.4 kbps data.

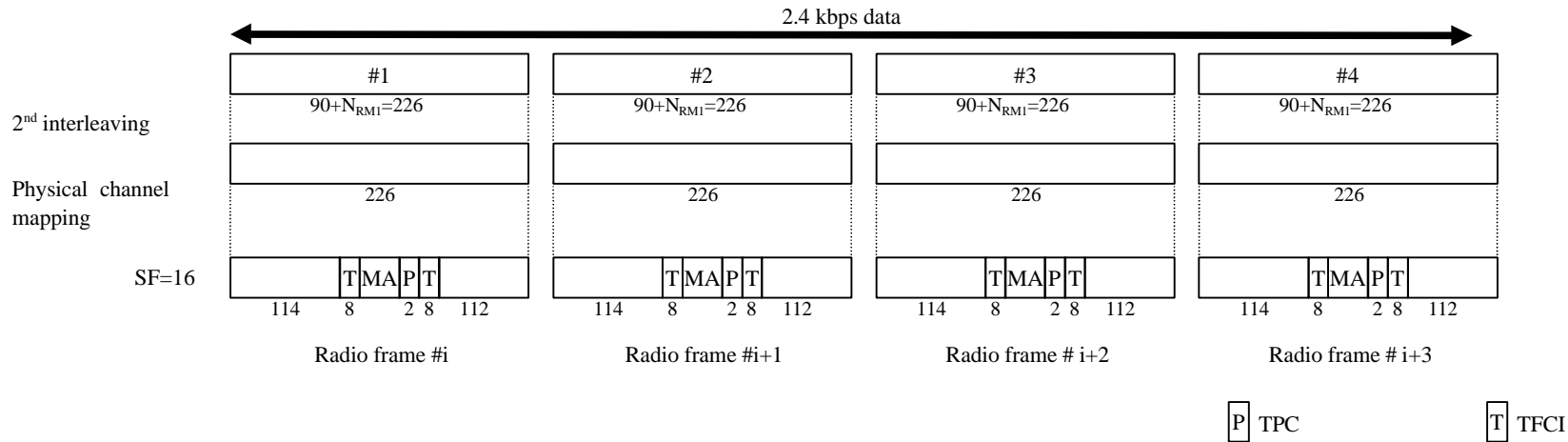

Figure 32: Channel coding and multiplexing example for Stand-alone mapping of 2.4 kbps data

Table 28: Physical channel parameters for Stand-alone mapping of 2.4 kbps data

Midamble	512 chips
Multi-codes and time slots	SF16 x 1 code x 1 time slot
TFCI	16 bits per user
TPC	2 bit

4.2.2.2.2 Example for multiplexing of 12.2 kbps data and 2.4 kbps data

<Note: This example can be applied to multiplexing AMR speech and DCCH.>

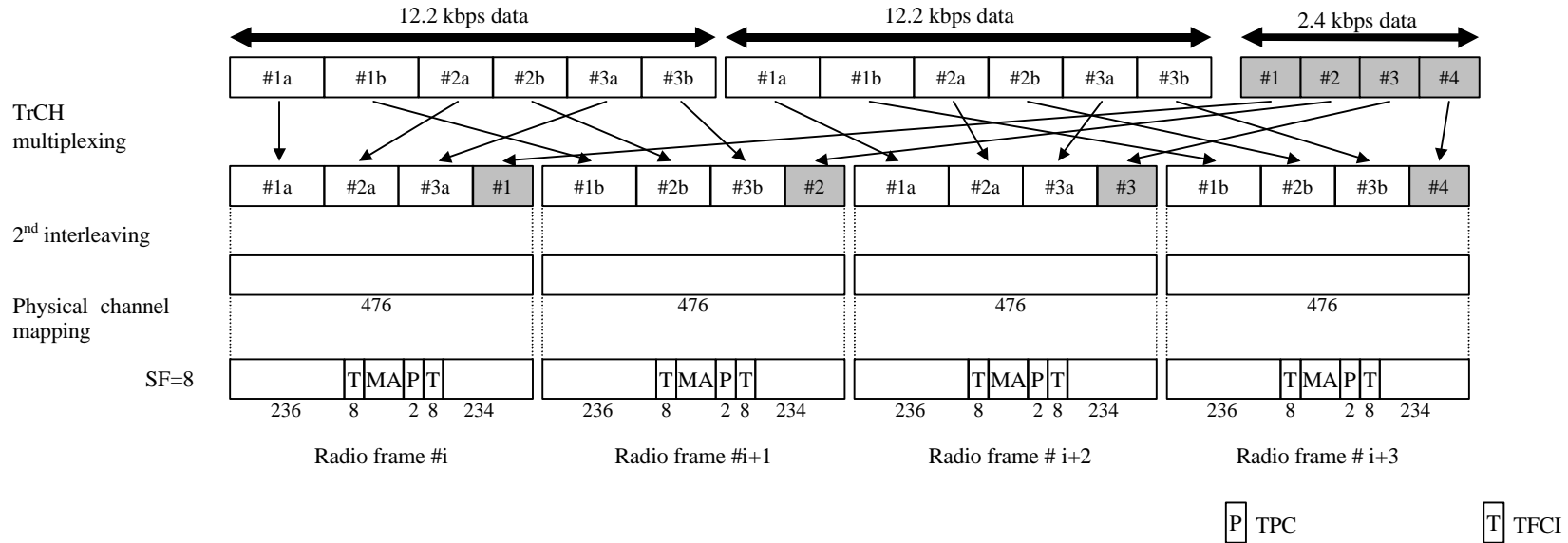

Figure 33: Channel coding and multiplexing example for multiplexing of 12.2 kbps data and 2.4 kbps data

Table 29: Physical channel parameters for multiplexing of 12.2 kbps data and 2.4 kbps data

Midamble	512 chips
Multi-codes and time slots	SF8 x 1 code x 1 time slot
TFCI	16 bits per user
TPC	2 bit

4.2.2.2.3 Example for multiplexing of 64/128/384 kbps packet data and 2.4 kbps data

<Note: This example can be applied to multiplexing 64/128/384 kbps packet data and DCCH.>

Table 30 shows example of physical channel parameters for multiplexing of 64/128/384 kbps packet data and 2.4 kbps data.

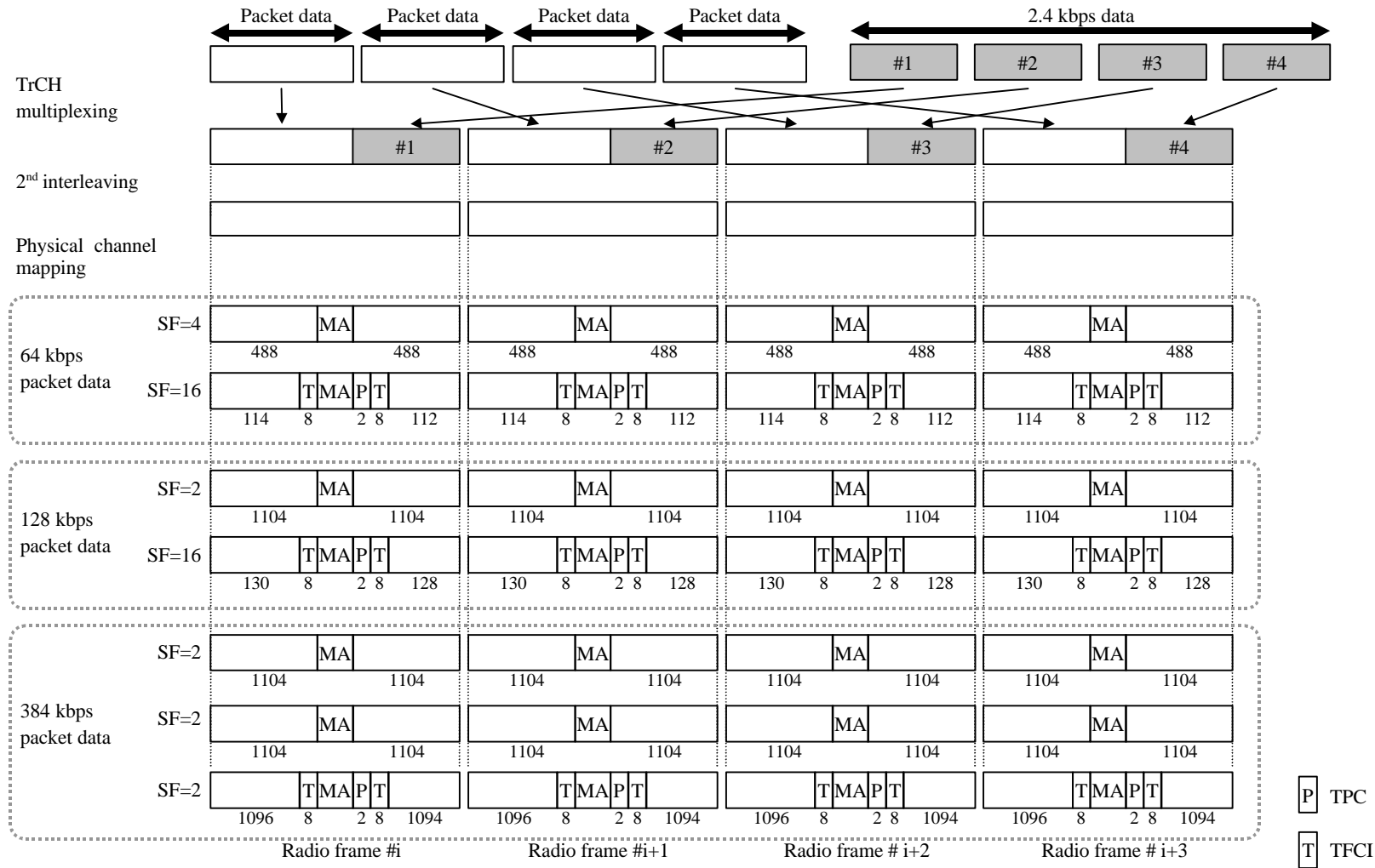

Figure 34: Channel coding and multiplexing example for multiplexing of 64/128/384 kbps packet data and 2.4 kbps data

**Table 30: Physical channel parameters for multiplexing of 64/128/384 kbps packet data and 2.4 kbps data**

Midamble	64 kbps	512 chips
	128 & 384 kbps	256 chips
Multi-code & time slots	64 kbps	{(SF16 x 1 code) + (SF4 x 1 code)} x 1 time slot
	128 kbps	{(SF16 x 1 code) + (SF2 x 1 code)} x 1 time slot
	384 kbps	SF2 x 1 code x 3 time slot
TFCI	16 bits per user	
TPC	2 bit	

Note: As an additional example, physical channels can also be mapped without using multicode per timeslot, e.g.  
for 64kbps: (SF16 x 1 code x 1 timeslot) + (SF4x 1 code x 1 timeslot)  
for 64kbps: (SF2 x 1 code x 1 timeslot)  
for 128kbps: (SF16 x 1 code x 1 timeslot) + (SF2x 1 code x 1 timeslot)  
for 128kbps: (SF1 x 1 code x 1 timeslot)

4.2.2.2.4 Example for multiplexing of 64 kbps data and 2.4 kbps data

<Note: This example can be applied to multiplexing ISDNs data and DCCH.>

Table 31 shows example of physical channel parameters for multiplexing of 64/128/384 kbps packet data and 2.4 kbps data.

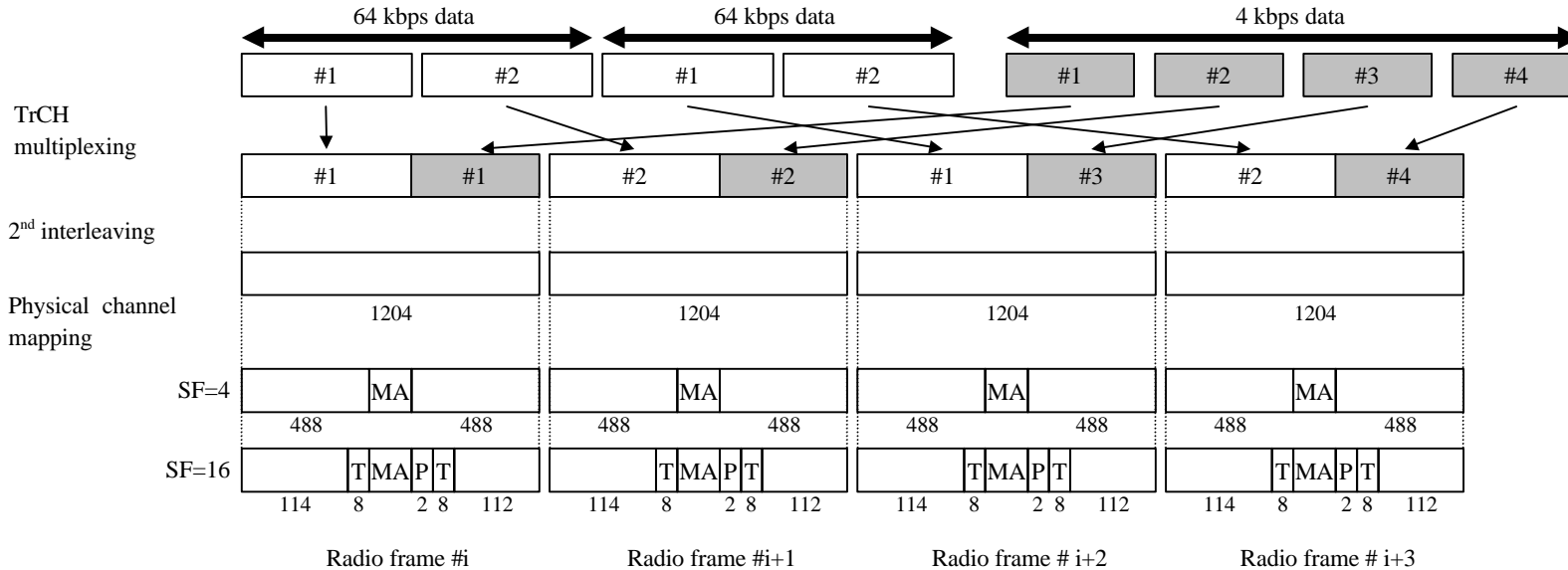

Figure 35: Channel coding and multiplexing example for multiplexing of 64 kbps packet data and 2.4 kbps data

Table 31: Physical channel parameters for multiplexing of 64 kbps packet data and 2.4 kbps data

Midamble	512 chips
Multi-codes & time slots	{{(SF16 x 1 code) + (SF4 x 1 code)} x 1 time slot
TFCI	16 bits per user
TPC	2 bit

Note: As an additional example, physical channels can also be mapped without using multicode per timeslot, e.g.  
 for 64kbps: (SF16 x 1 code x 1 timeslot) + (SF4x 1 code x 1 timeslot)  
 for 64kbps: (SF2 x 1 code x 1 timeslot)

---

## 5 History

<b>Document history</b>		
V0.0.1	1999-11-25	First version created by the editor.
<u>V1.0.0</u>	<u>1999-12-15</u>	<u>Version agreed at RAN-WG1#9</u>
<p>Editors for 3GPP TSG RAN <del>S1.14</del><u>TR 25.944</u> are:</p> <p>Takehiro Nakamura NTT DoCoMo R&amp;D Headquarters Tel: +81 468 40 31 90 Mobile: +81 30 20 05 542 Fax: +81 468 40 38 40 E-mail: takehiro@wsp.yrp.nttdocomo.co.jp</p> <p>This document is written in Microsoft Word 2000.</p>		