

**Agenda item:**

**Source:** Ericsson  
**Title:** CR 25.211-007: Compressed mode by higher layer scheduling  
**Document for:** Decision

---

It was proposed in TSGR1#8(99)g77 that compressed mode by higher layer scheduling should be allowed. This was agreed at TSG-RAN Working Group 1 meeting #8 and it was recommended that a CR should be generated from the text proposal in g77.

The following changes have been done compared to the text proposal in g77:

- There are now at most two compressed slot formats for each normal slot format (three in g77). There has been a discussion on the WG1 reflector and there seemed to be agreement that this change could be done in order to avoid a shared DPDCH and DPCCH symbol.
- UL Pilot patterns were missing for 3 and 4 pilot bits. The included pilot patterns were proposed on the reflector by LGIC and NEC. There seemed to be agreement on these patterns and they were therefore included in this CR.
- The DL TFCI field is moved to after the TPC field to avoid a split TFCI field in compressed mode. This has also been discussed on the reflector and again there seemed to be agreement. Further, there seemed to be agreement that the slot format for SF 512 should be changed to allow for 1 slot TPC delay. This has also been included in this CR.
- The bits/frame column has been removed from table 11. In normal mode this column contained different sums of the different bits/slot columns. In compressed mode the values are dependent on the number of transmitted slots and the frame structure. The number of bits/frame for the DPCCH for slot format 3A with frame structure B for example becomes  $8N_{Tr} + N_{pilot} + N_{TPC}$ . Using this kind of expression makes the table very large. It is therefore proposed that it is removed.
- A typo has also been corrected in format 3A of table 11.

# CHANGE REQUEST

Please see embedded help file at the bottom of this page for instructions on how to fill in this form correctly.

**25.211 CR 007**

Current Version: **3.0.0**

GSM (AA.BB) or 3G (AA.BBB) specification number ↑

↑ CR number as allocated by MCC support team

For submission to: **TSG-RAN #6** for approval   
list expected approval meeting # here ↑ for information

Strategic  (for SMG use only)  
non-strategic

Form: CR cover sheet, version 2 for 3GPP and SMG The latest version of this form is available from: ftp://ftp.3gpp.org/Information/CR-Form-v2.doc

**Proposed change affects:** (U)SIM  ME  UTRAN / Radio  Core Network   
(at least one should be marked with an X)

**Source:** Ericsson **Date:** 1999-11-23

**Subject:** Introduction of compressed mode by higher layer scheduling

**Work item:**

<b>Category:</b> <i>(only one category shall be marked with an X)</i>	F Correction	<input type="checkbox"/>	<b>Release:</b>	Phase 2	<input type="checkbox"/>
	A Corresponds to a correction in an earlier release	<input type="checkbox"/>		Release 96	<input type="checkbox"/>
	B Addition of feature	<input checked="" type="checkbox"/>		Release 97	<input type="checkbox"/>
	C Functional modification of feature	<input type="checkbox"/>		Release 98	<input type="checkbox"/>
	D Editorial modification	<input type="checkbox"/>		Release 99	<input checked="" type="checkbox"/>
			Release 00	<input type="checkbox"/>	

**Reason for change:** Compressed mode by higher layer scheduling is supported in 25.302 but has been missing in layer 1 specifications.

**Clauses affected:** 5.2.1, 5.3.2, 5.3.2.2

<b>Other specs affected:</b>	Other 3G core specifications	<input type="checkbox"/>	→ List of CRs:	
	Other GSM core specifications	<input type="checkbox"/>	→ List of CRs:	
	MS test specifications	<input type="checkbox"/>	→ List of CRs:	
	BSS test specifications	<input type="checkbox"/>	→ List of CRs:	
	O&M specifications	<input type="checkbox"/>	→ List of CRs:	

**Other comments:** This CR also moves the existing slot formats for compressed mode by spreading factor reduction from 25.212 to 25.211.



<----- double-click here for help and instructions on how to create a CR.

Time slot: A Time slot is a unit which consists of fields containing bits. The number of bits per time slot depends on the physical channel.

## 5.1 The physical resource

The basic physical resource is the code/frequency plane. In addition, on the uplink, different information streams may be transmitted on the I and Q branch. Consequently, a physical channel corresponds to a specific carrier frequency, code, and, on the uplink, relative phase (0 or  $\pi/2$ ).

## 5.2 Uplink physical channels

### 5.2.1 Dedicated uplink physical channels

There are two types of uplink dedicated physical channels, the uplink Dedicated Physical Data Channel (uplink DPDCH) and the uplink Dedicated Physical Control Channel (uplink DPCCH).

The DPDCH and the DPCCH are I/Q code multiplexed within each radio frame (see [4]).

The uplink DPDCH is used to carry dedicated data generated at Layer 2 and above, i.e. the dedicated transport channel (DCH). There may be zero, one, or several uplink DPDCHs on each Layer 1 connection.

The uplink DPCCH is used to carry control information generated at Layer 1. The Layer 1 control information consists of known pilot bits to support channel estimation for coherent detection, transmit power-control (TPC) commands, feedback information (FBI), and an optional transport-format combination indicator (TFCI). The transport-format combination indicator informs the receiver about the instantaneous parameters of the different transport channels multiplexed on the uplink DPDCH, and corresponds to the data transmitted in the same frame. It is the UTRAN that determines if a TFCI should be transmitted, hence making it mandatory for all UEs to support the use of TFCI in the uplink. There is one and only one uplink DPCCH on each Layer 1 connection.

Figure 1 shows the frame structure of the uplink dedicated physical channels. Each frame of length 10 ms is split into 15 slots, each of length  $T_{slot} = 2560$  chips, corresponding to one power-control period. A super frame corresponds to 72 consecutive frames, i.e. the super-frame length is 720 ms.

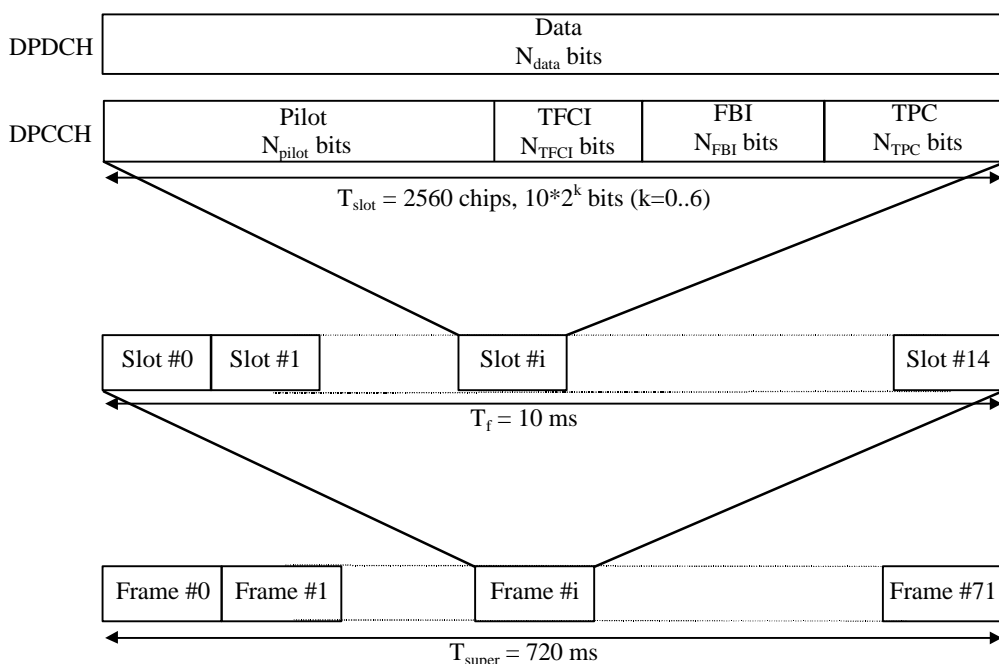

Figure 1: Frame structure for uplink DPDCH/DPCCH

The parameter k in figure 1 determines the number of bits per uplink DPDCH/DPCCH slot. It is related to the

spreading factor SF of the physical channel as  $SF = 256/2^k$ . The DPDCH spreading factor may thus range from 256 down to 4. Note that an uplink DPDCH and uplink DPCCH on the same Layer 1 connection generally are of different rates, i.e. have different spreading factors and different values of k.

The exact number of bits of the different uplink DPCCH fields ( $N_{\text{pilot}}$ ,  $N_{\text{TFCI}}$ ,  $N_{\text{FBI}}$ , and  $N_{\text{TPC}}$ ) is determined in table 2. The field order and total number of bits/slot are fixed, though the number of bits per field may vary during a connection.

The values for the number of bits per field are given in table 1 and table 2. The channel bit and symbol rates given in table 1 are the rates immediately before spreading. The pilot patterns are given in table 3 and table 4, the TPC bit pattern is given in table 5.

The  $N_{\text{FBI}}$  bits are used to support techniques requiring feedback between the UE and the UTRAN Access Point (=cell transceiver), including closed loop mode transmit diversity and site selection diversity (SSDT). The exact details of the FBI field are shown in figure 2 and described below.

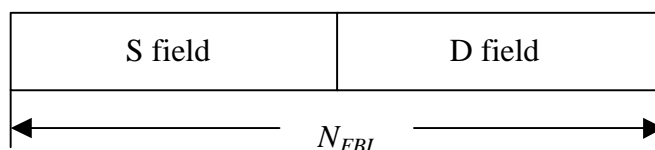

**Figure 2: Details of FBI field**

The S field is used for SSDT signalling, while the D field is used for FB Mode Transmit Diversity Signalling. Each of the S and D fields can be length 0, 1 or 2, with a total FBI field size  $N_{\text{FBI}}$  according to table 2 (DPCCH fields). Simultaneous use of SSDT power control and FB Mode Transmit Diversity requires that both the S and D fields be of length 1. The use of these FBI fields is described in [5].

**Table 1: DPDCH fields**

Slot Format #i	Channel Bit Rate (kbps)	Channel Symbol Rate (ksps)	SF	Bits/Frame	Bits/Slot	$N_{\text{data}}$
0	15	15	256	150	10	10
1	30	30	128	300	20	20
2	60	60	64	600	40	40
3	120	120	32	1200	80	80
4	240	240	16	2400	160	160
5	480	480	8	4800	320	320
6	960	960	4	9600	640	640

There are two types of Uplink Dedicated Physical Channels; those that include TFCI(e.g. for several simultaneous services) and those that do not include TFCI(e.g. for fixed-rate services). These types are reflected by the duplicated rows of table 2. [In compressed mode, DPCCH slot formats with TFCI fields are changed. There are two possible compressed slot formats for each normal slot format. They are labelled A and B and the selection between them is dependent on the number of slots that are transmitted in each frame in compressed mode.](#) The channel bit and symbol rates given in table 2 are the rates immediately before spreading.

Table 2: DPCCH fields

Slot Format #i	Channel Bit Rate (kbps)	Channel Symbol Rate (ksps)	SF	Bits/Frame	Bits/Slot	N <sub>pilot</sub>	N <sub>TPC</sub>	N <sub>TFCI</sub>	N <sub>FBI</sub>	Transmitted slots per radio frame
0	15	15	256	150	10	6	2	2	0	15
0A	15	15	256	150	10	5	2	3	0	10-14
0B	15	15	256	150	10	4	2	4	0	8-9
1	15	15	256	150	10	8	2	0	0	8-15
2	15	15	256	150	10	5	2	2	1	15
2A	15	15	256	150	10	4	2	3	1	10-14
2B	15	15	256	150	10	3	2	4	1	8-9
3	15	15	256	150	10	7	2	0	1	8-15
4	15	15	256	150	10	6	2	0	2	8-15
5	15	15	256	150	10	5	1	2	2	15
5A	15	15	256	150	10	4	1	3	2	10-14
5B	15	15	256	150	10	3	1	4	2	8-9

Slot Format #i	Channel Bit Rate (kbps)	Channel Symbol Rate (ksps)	SF	Bits/Frame	Bits/Slot	N <sub>pilot</sub>	N <sub>TFCI</sub>	N <sub>FBI</sub>	N <sub>TPC</sub>
0	15	15	256	150	10	6	2	0	2
1	15	15	256	150	10	8	0	0	2
2	15	15	256	150	10	5	2	4	2
3	15	15	256	150	10	7	0	4	2
4	15	15	256	150	10	6	0	2	2
5	15	15	256	150	10	5	2	2	4

The pilot bit pattern is described in table 3 and table 4. The shadowed part can be used as frame synchronization words. (The value of the pilot bit other than the frame synchronization word shall be “1”.)

Table 3: Pilot bit patterns for uplink DPCCH with N<sub>pilot</sub> = 3, 4, 5 and 6

Bit #	N <sub>pilot</sub> = 3			N <sub>pilot</sub> = 4				N <sub>pilot</sub> = 5					N <sub>pilot</sub> = 6					
	0	1	2	0	1	2	3	0	1	2	3	4	0	1	2	3	4	5
Slot #0	1	1	1	1	1	1	1	1	1	1	1	0	1	1	1	1	1	0
1	0	0	1	1	0	0	1	0	0	1	1	0	1	0	0	1	1	0
2	0	1	1	1	0	1	1	0	1	1	0	1	1	0	1	1	0	1
3	0	0	1	1	0	0	1	0	0	1	0	0	1	0	0	1	0	0
4	1	0	1	1	1	0	1	1	0	1	0	1	1	1	0	1	0	1
5	1	1	1	1	1	1	1	1	1	1	1	0	1	1	1	1	1	0
6	1	1	1	1	1	1	1	1	1	1	0	0	1	1	1	1	0	0
7	1	0	1	1	1	0	1	1	0	1	0	0	1	1	0	1	0	0
8	0	1	1	1	0	1	1	0	1	1	1	0	1	0	1	1	1	0
9	1	1	1	1	1	1	1	1	1	1	1	1	1	1	1	1	1	1
10	0	1	1	1	0	1	1	0	1	1	0	1	1	0	1	1	0	1
11	1	0	1	1	1	0	1	1	0	1	1	1	1	1	0	1	1	1
12	1	0	1	1	1	0	1	1	0	1	0	0	1	1	0	1	0	0
13	0	0	1	1	0	0	1	0	0	1	1	1	1	0	0	1	1	1
14	0	0	1	1	0	0	1	0	0	1	1	1	1	0	0	1	1	1

**Table 3: Pilot bit patterns for uplink DPCCH with  $N_{pilot} = 5$  and 6**

Bit #	$N_{pilot} = 5$					$N_{pilot} = 6$					
	0	1	2	3	4	0	1	2	3	4	5
Slot #0	1	1	1	1	0	1	1	1	1	1	0
1	0	0	1	1	0	1	0	0	1	1	0
2	0	1	1	0	1	1	0	1	1	0	1
3	0	0	1	0	0	1	0	0	1	0	0
4	1	0	1	0	1	1	1	0	1	0	1
5	1	1	1	1	0	1	1	1	1	1	0
6	1	1	1	0	0	1	1	1	1	0	0
7	1	0	1	0	0	1	1	0	1	0	0
8	0	1	1	1	0	1	1	1	1	1	0
9	1	1	1	1	1	1	1	1	1	1	1
10	0	1	1	0	1	1	0	1	1	0	1
11	1	0	1	1	1	1	0	1	1	1	1
12	1	0	1	0	0	1	1	0	1	0	0
13	0	0	1	1	1	1	0	0	1	1	1
14	0	0	1	1	1	1	0	0	1	1	1

**Table 4: Pilot bit patterns for uplink DPCCH with  $N_{pilot} = 7$  and 8**

Bit #	$N_{pilot} = 7$							$N_{pilot} = 8$							
	0	1	2	3	4	5	6	0	1	2	3	4	5	6	7
Slot #0	1	1	1	1	1	0	1	1	1	1	1	1	1	1	0
1	1	0	0	1	1	0	1	1	0	1	0	1	1	1	0
2	1	0	1	1	0	1	1	1	0	1	1	1	0	1	1
3	1	0	0	1	0	0	1	1	0	1	0	1	0	1	0
4	1	1	0	1	0	1	1	1	1	1	0	1	0	1	1
5	1	1	1	1	1	0	1	1	1	1	1	1	1	1	0
6	1	1	1	1	0	0	1	1	1	1	1	1	0	1	0
7	1	1	0	1	0	0	1	1	1	1	0	1	0	1	0
8	1	0	1	1	1	0	1	1	0	1	1	1	1	1	0
9	1	1	1	1	1	1	1	1	1	1	1	1	1	1	1
10	1	0	1	1	0	1	1	1	0	1	1	1	0	1	1
11	1	1	0	1	1	1	1	1	1	1	0	1	1	1	1
12	1	1	0	1	0	0	1	1	1	1	0	1	0	1	0
13	1	0	0	1	1	1	1	1	0	1	0	1	1	1	1
14	1	0	0	1	1	1	1	1	0	1	0	1	1	1	1

The relationship between the TPC bit pattern and transmitter power control command is presented in table 5.

**Table 5: TPC Bit Pattern**

TPC Bit Pattern		Transmitter power control command
$N_{TPC} = 1$	$N_{TPC} = 2$	
1	11	1
0	00	0

For slot formats using TFCI, the TFCI value in each radio frame corresponds to a certain combination of bit rates of the DCHs currently in use. This correspondence is (re-)negotiated at each DCH addition/removal. The mapping of the TFCI bits onto slots is described in [3].

Multi-code operation is possible for the uplink dedicated physical channels. When multi-code transmission is used, several parallel DPDCH are transmitted using different channelization codes, see [4]. However, there is only one DPCCH per connection.

## 5.2.2 Common uplink physical channels

### 5.2.2.1 Physical Random Access Channel (PRACH)

The Physical Random Access Channel (PRACH) is used to carry the RACH.

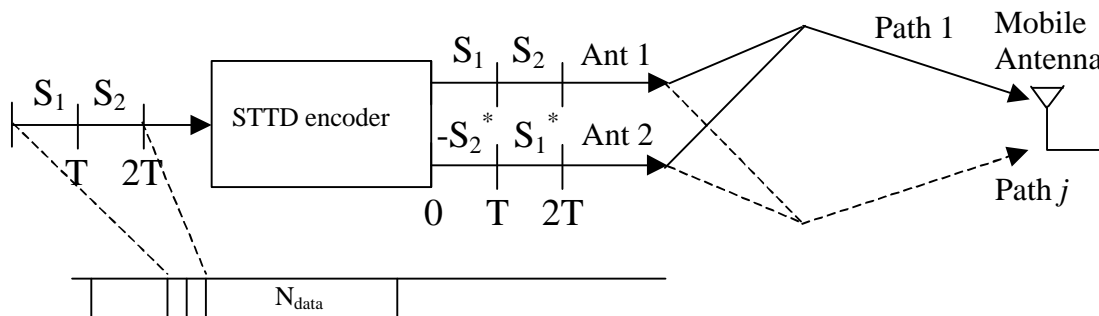

**Figure 8: Block diagram of STTD encoder. The symbols  $S_1, S_2$  are QPSK or discontinuous transmission (DTX) symbols and  $T$  denotes the symbol time**

5.3.1.1.2 Time Switched Transmit Diversity for SCH (TSTD)

TSTD is optional in UTRAN. TSTD support is mandatory at the UE. A block diagram of the transmitter using TSTD for SCH and STTD for P-CCPCH is shown in figure 9.

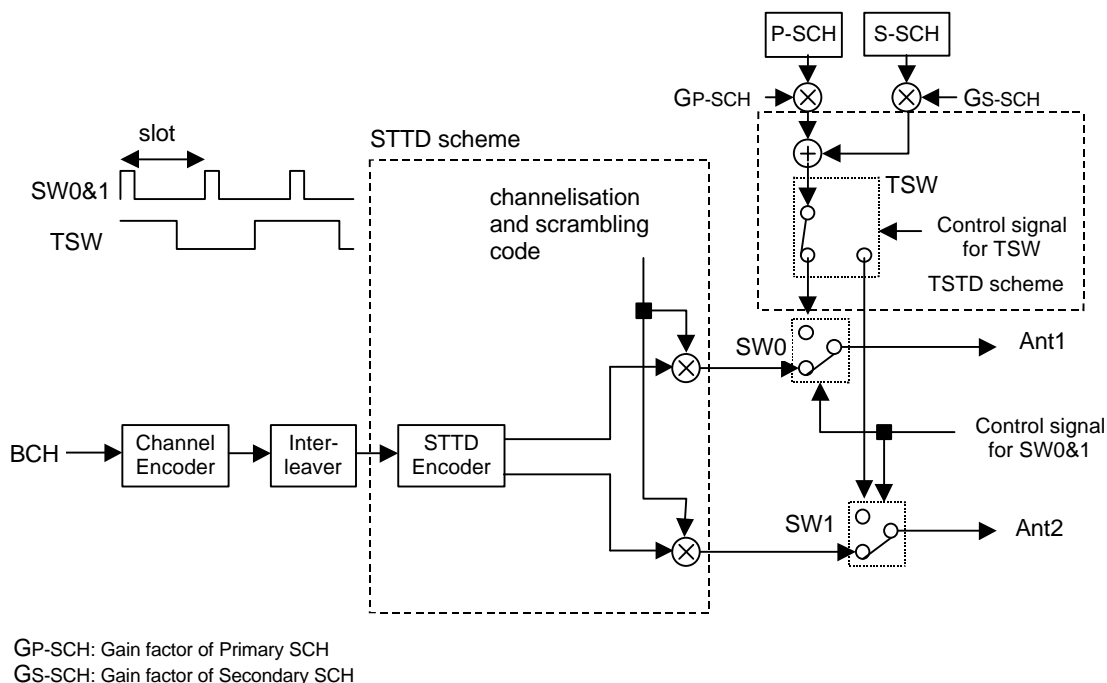

**Figure 9: Multiplexing scheme of SCH (TSTD) and P-CCPCH (STTD)**

5.3.2 Dedicated downlink physical channels

There is only one type of downlink dedicated physical channel, the Downlink Dedicated Physical Channel (downlink DPCH).

Within one downlink DPCH, dedicated data generated at Layer 2 and above, i.e. the dedicated transport channel (DCH), is transmitted in time-multiplex with control information generated at Layer 1 (known pilot bits, TPC commands, and an optional TFCI). The downlink DPCH can thus be seen as a time multiplex of a downlink DPDCH and a downlink DPCCCH, compare section 5.2.1. It is the UTRAN that determines if a TFCI should be transmitted, hence making it mandatory for all UEs to support the use of TFCI in the downlink.

Figure 10 shows the frame structure of the downlink DPCH. Each frame of length 10 ms is split into 15 slots, each of length  $T_{slot} = 2560$  chips, corresponding to one power-control period. A super frame corresponds to 72 consecutive frames, i.e. the super-frame length is 720 ms.



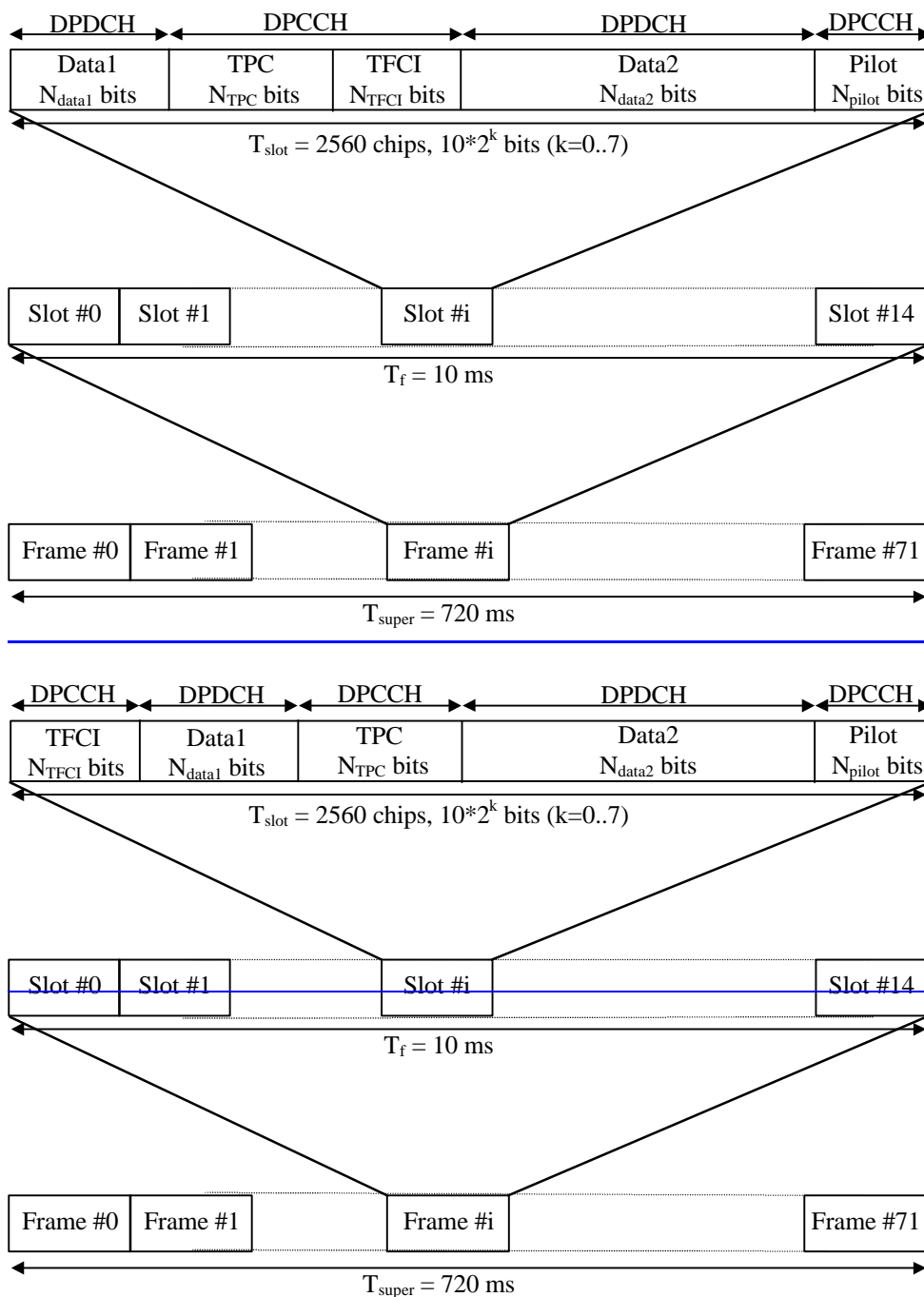

**Figure 10: Frame structure for downlink DPCH**

The parameter  $k$  in figure 10 determines the total number of bits per downlink DPCH slot. It is related to the spreading factor  $SF$  of the physical channel as  $SF = 512/2^k$ . The spreading factor may thus range from 512 down to 4.

The exact number of bits of the different downlink DPCH fields ( $N_{pilot}$ ,  $N_{TPC}$ ,  $N_{TFCI}$ ,  $N_{data1}$  and  $N_{data2}$ ) is determined in table 11. The overhead due to the DPCCH transmission has to be negotiated at the connection set-up and can be re-negotiated during the communication, in order to match particular propagation conditions.

There are basically two types of downlink Dedicated Physical Channels; those that include TFCI (e.g. for several simultaneous services) and those that do not include TFCI (e.g. for fixed-rate services). These types are reflected by the duplicated rows of table 11. In compressed mode, a different slot format is used compared to normal mode. There are two possible compressed slot formats that are labelled A and B. Format B is used for compressed mode by spreading factor reduction and format A is used for all other transmission time reduction methods. The channel bit and symbol rates given in table 11 are the rates immediately before spreading.

**Table 11: DPDCH and DPCCH fields.**

Slot Format #i	Channel Bit Rate (kbps)	Channel Symbol Rate (ksps)	SF	Bits/Slot	DPDCH Bits/Slot		DPCCH Bits/Slot			Transmitted slots per radio frame N <sub>Tr</sub>
					N <sub>Data1</sub>	N <sub>Data2</sub>	N <sub>TPC</sub>	N <sub>TFCI</sub>	N <sub>Pilot</sub>	
0	15	7.5	512	10	0	4	2	0	4	15
0A	15	7.5	512	10	0	4	2	0	4	8-14
0B	30	15	256	20	0	8	4	0	8	8-14
1	15	7.5	512	10	0	2	2	2	4	15
1B	30	15	256	20	0	4	4	4	8	8-14
2	30	15	256	20	2	14	2	0	2	15
2A	30	15	256	20	2	14	2	0	2	8-14
2B	60	30	128	40	4	28	4	0	4	8-14
3	30	15	256	20	2	12	2	2	2	15
3A	30	15	256	20	2	10	2	4	2	8-14
3B	60	30	128	40	4	24	4	4	4	8-14
4	30	15	256	20	2	12	2	0	4	15
4A	30	15	256	20	2	12	2	0	4	8-14
4B	60	30	128	40	4	24	4	0	8	8-14
5	30	15	256	20	2	10	2	2	4	15
5A	30	15	256	20	2	8	2	4	4	8-14
5B	30	15	128	40	4	20	4	4	8	8-14
6	30	15	256	20	2	8	2	0	8	15
6A	30	15	256	20	2	8	2	0	8	8-14
6B	60	30	128	40	4	16	4	0	16	8-14
7	30	15	256	20	2	6	2	2	8	15
7A	30	15	256	20	2	4	2	4	8	8-14
7B	60	30	128	40	4	12	4	4	16	8-14
8	60	30	128	40	6	28	2	0	4	15
8A	60	30	128	40	6	28	2	0	4	8-14
8B	120	60	64	80	12	56	4	0	8	8-14
9	60	30	128	40	6	26	2	2	4	15
9A	60	30	128	40	6	24	2	4	4	8-14
9B	120	60	64	40	12	52	4	4	8	8-14
10	60	30	128	40	6	24	2	0	8	15
10A	60	30	128	40	6	24	2	0	8	8-14
10B	120	60	64	80	12	48	4	0	16	8-14
11	60	30	128	40	6	22	2	2	8	15
11A	60	30	128	40	6	20	2	4	8	8-14
11B	120	60	64	80	12	44	4	4	16	8-14
12	120	60	64	80	12	48	4	8*	8	15
12A	120	60	64	80	12	40	4	16*	8	8-14
12B	240	120	32	160	24	96	8	16*	16	8-14
13	240	120	32	160	28	112	4	8*	8	15
13A	240	120	32	160	28	104	4	16*	8	8-14
13B	480	240	16	320	56	224	8	16*	16	8-14
14	480	240	16	320	56	232	8	8*	16	15
14A	480	240	16	320	56	224	8	16*	16	8-14
14B	960	480	8	640	112	464	16	16*	32	8-14
15	960	480	8	640	120	488	8	8*	16	15
15A	960	480	8	640	120	480	8	16*	16	8-14
15B	1920	960	4	1280	240	976	16	16*	32	8-14
16	1920	960	4	1280	248	1000	8	8*	16	15
16A	1920	960	4	1280	248	992	8	16*	16	8-14

Slot Format #	Channel Bit Rate (kbps)	Channel Symbol Rate (ksps)	SF	Bits/Frame			Bits/Slot	DPDCH Bits/Slot		DPCCH Bits/Slot		
				DPDCH	DPCCH	TOT		NData1	NData2	NTFCI	NTPC	Npilot
0	15	7.5	512	60	90	150	40	2	2	0	2	4
1	15	7.5	512	30	120	150	40	0	2	2	2	4
2	30	15	256	240	60	300	20	2	14	0	2	2
3	30	15	256	210	90	300	20	0	14	2	2	2
4	30	15	256	210	90	300	20	2	12	0	2	4
5	30	15	256	180	120	300	20	0	12	2	2	4
6	30	15	256	450	150	300	20	2	8	0	2	8
7	30	15	256	120	180	300	20	0	8	2	2	8
8	60	30	128	510	90	600	40	6	28	0	2	4
9	60	30	128	480	120	600	40	4	28	2	2	4
10	60	30	128	450	150	600	40	6	24	0	2	8
11	60	30	128	420	180	600	40	4	24	2	2	8
12	120	60	64	900	300	1200	80	4	56	8*	4	8
13	240	120	32	2100	300	2400	160	20	120	8*	4	8
14	480	240	16	4320	480	4800	320	48	240	8*	8	16
15	960	480	8	9120	480	9600	640	112	496	8*	8	16
16	1920	960	4	18720	480	19200	1280	240	1008	8*	8	16

\* If TFCI bits are not used, then DTX shall be used in TFCI field.

Note 1: Compressed mode is only supported through spreading factor reduction for SF=512 with TFCI.

Note 2: Compressed mode by spreading factor reduction is not supported for SF=4.

The pilot symbol pattern is described in table 12. The shadowed part can be used as frame synchronization words. (The symbol pattern of the pilot symbols other than the frame synchronization word shall be “11”.) In table 12, the transmission order is from left to right. (Each two-bit pair represents an I/Q pair of QPSK modulation.)

In downlink compressed mode through spreading factor reduction, the number of bits in the TPC and Pilot fields are doubled. Symbol repetition is used to fill up the fields. Denote the bits in one of these fields in normal mode by  $x_1, x_2, x_3, \dots, x_X$ . In compressed mode the following bit sequence is sent in corresponding field:  $x_1, x_2, x_1, x_2, x_3, x_4, x_3, x_4, \dots, x_X$ .

**Table 12: Pilot Symbol Pattern**

Symbol #	Npilot = 2		Npilot = 4		Npilot = 8				Npilot = 16							
	0	1	0	1	0	1	2	3	0	1	2	3	4	5	6	7
Slot #0	11	11	11	11	11	11	11	10	11	11	11	10	11	11	11	10
1	00	11	00	11	11	00	11	10	11	00	11	10	11	11	11	00
2	01	11	01	11	11	01	11	01	11	01	11	01	11	10	11	00
3	00	11	00	11	11	00	11	00	11	00	11	00	11	01	11	10
4	10	11	10	11	11	10	11	01	11	10	11	01	11	11	11	11
5	11	11	11	11	11	11	11	10	11	11	11	10	11	01	11	01
6	11	11	11	11	11	11	11	00	11	11	11	00	11	10	11	11
7	10	11	10	11	11	10	11	00	11	10	11	00	11	10	11	00
8	01	11	01	11	11	01	11	10	11	01	11	10	11	00	11	11
9	11	11	11	11	11	11	11	11	11	11	11	11	11	00	11	11
10	01	11	01	11	11	01	11	01	11	01	11	01	11	11	11	10
11	10	11	10	11	11	10	11	11	11	10	11	11	11	00	11	10
12	10	11	10	11	11	10	11	00	11	10	11	00	11	01	11	01
13	00	11	00	11	11	00	11	11	11	00	11	11	11	00	11	00
14	00	11	00	11	11	00	11	11	11	00	11	11	11	10	11	01

The relationship between the TPC symbol and the transmitter power control command is presented in table 13

**Table 13: TPC Bit Pattern**

TPC Bit Pattern			Transmitter power control command
$N_{TPC} = 2$	$N_{TPC} = 4$	$N_{TPC} = 8$	
11	1111	11111111	1
00	0000	00000000	0

For slot formats using TFCI, the TFCI value in each radio frame corresponds to a certain combination of bit rates of the DCHs currently in use. This correspondence is (re-)negotiated at each DCH addition/removal. The mapping of the TFCI bits onto slots is described in [3].

When the total bit rate to be transmitted on one downlink CCTrCH exceeds the maximum bit rate for a downlink physical channel, multicode transmission is employed, i.e. several parallel downlink DPCHs are transmitted for one CCTrCH using the same spreading factor. In this case, the Layer 1 control information is put on only the first downlink DPCH. The additional downlink DPCHs belonging to the CCTrCH do not transmit any data during the corresponding time period, see figure 11.

In the case of several CCTrCHs of dedicated type for one UE different spreading factors can be used for each CCTrCH and only one DPCH would be transmitted for them in the downlink.

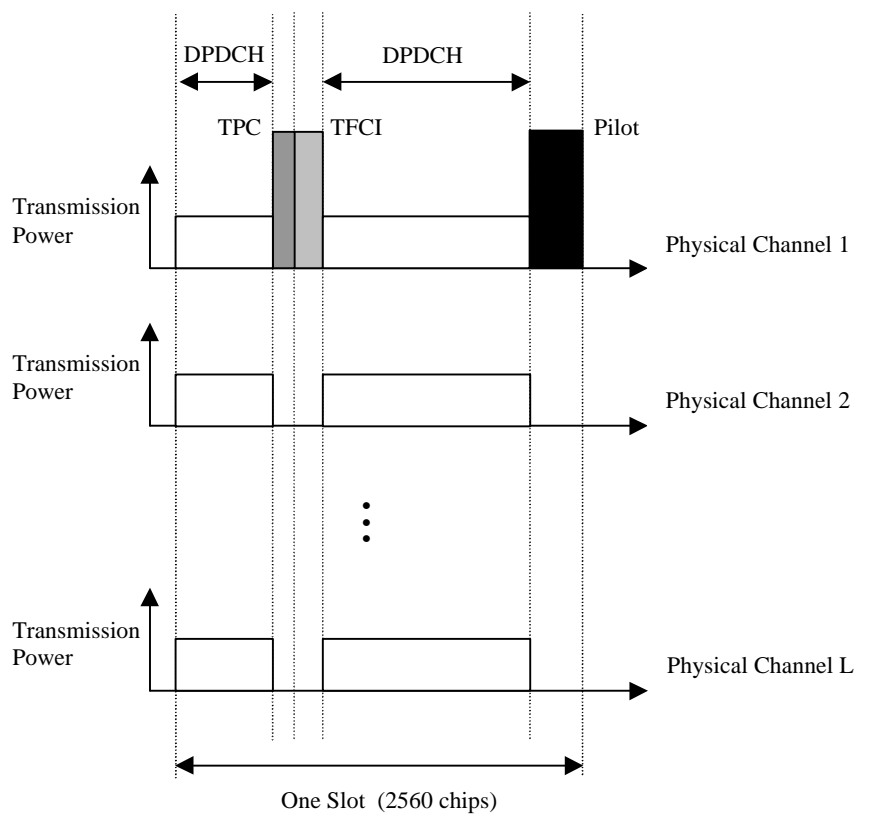

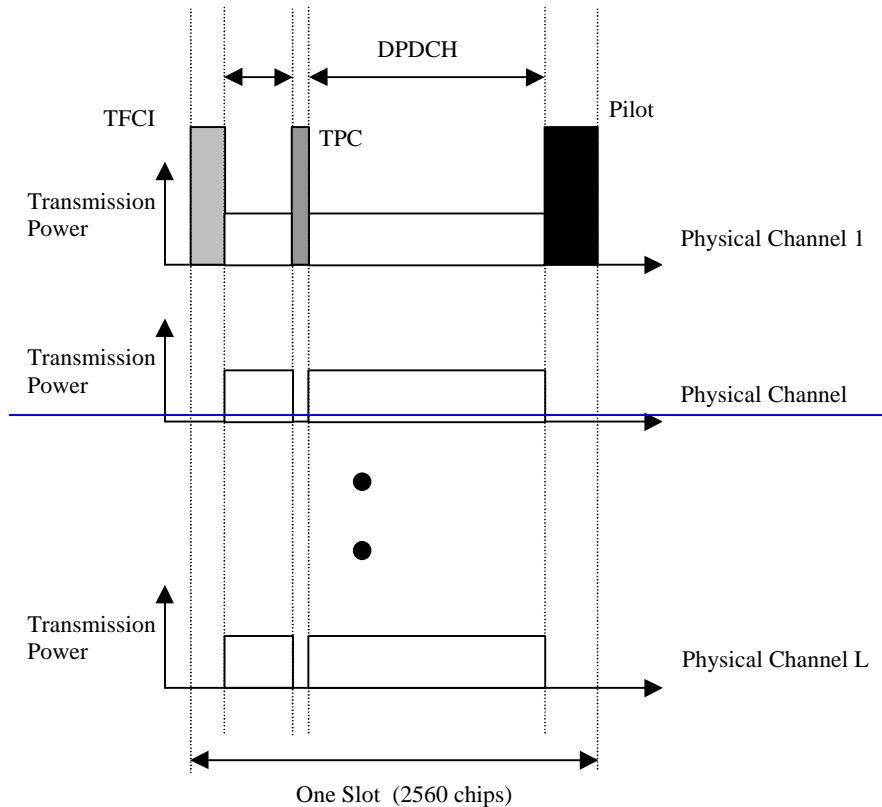

Figure 11: Downlink slot format in case of multi-code transmission

5.3.2.1 STTD for DPCH

The block diagrams shown in figure 7 and figure 8 are used to STTD encode the DPDCH, TPC and TFCI symbols. The pilot symbol pattern for the DPCH channel transmitted on the diversity antenna is given in table 14. In the SF=512 DPCH, if there is only one dedicated pilot symbol, it is STTD encoded together with the last symbol (data or DTX) of the second data field (data2) of the slot. For the SF=512 DPCH the last odd data symbol in every radio frame is not STTD encoded and the same symbol is transmitted with equal power from the two antennas.

Table 14: Pilot pattern of the DPCH channel for the diversity antenna using STTD

	N <sub>pilot</sub> = 2			N <sub>pilot</sub> = 4				N <sub>pilot</sub> = 8				N <sub>pilot</sub> = 16						
Symbol #	0	0	1	0	1	2	3	0	1	2	3	4	5	6	7			
Slot #0	01	01	10	11	00	00	10	11	00	00	10	11	00	00	10			
1	10	10	10	11	00	00	01	11	00	00	01	11	10	00	10			
2	11	11	10	11	11	00	00	11	11	00	00	11	10	00	11			
3	10	10	10	11	10	00	01	11	10	00	01	11	00	00	00			
4	00	00	10	11	11	00	11	11	11	00	11	11	01	00	10			
5	01	01	10	11	00	00	10	11	00	00	10	11	11	00	00			
6	01	01	10	11	10	00	10	11	10	00	10	11	01	00	11			
7	00	00	10	11	10	00	11	11	10	00	11	11	10	00	11			
8	11	11	10	11	00	00	00	11	00	00	00	11	01	00	01			
9	01	01	10	11	01	00	10	11	01	00	10	11	01	00	01			
10	11	11	10	11	11	00	00	11	11	00	00	11	00	00	10			
11	00	00	10	11	01	00	11	11	01	00	11	11	00	00	01			
12	00	00	10	11	10	00	11	11	10	00	11	11	11	00	00			
13	10	10	10	11	01	00	01	11	01	00	01	11	10	00	01			
14	10	10	10	11	01	00	01	11	01	00	01	11	11	00	11			

### 5.3.2.2 Dedicated channel pilots with closed loop mode transmit diversity

In closed loop mode 1 orthogonal pilot patterns are used between the transmit antennas. Pilot patterns defined in the table 12 will be used on the non-diversity antenna and pilot patterns defined in the table 14 on the diversity antenna. This is illustrated in the figure 12 a which indicates the difference in the pilot patterns with different shading.

In closed loop mode 2 same pilot pattern is used on both of the antennas (see figure 12 b). The pattern to be used is according to the table 12.

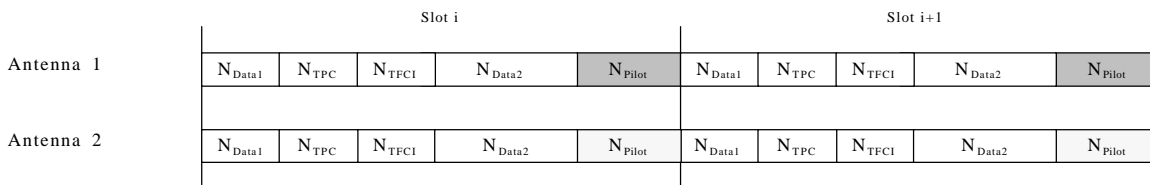

(a)

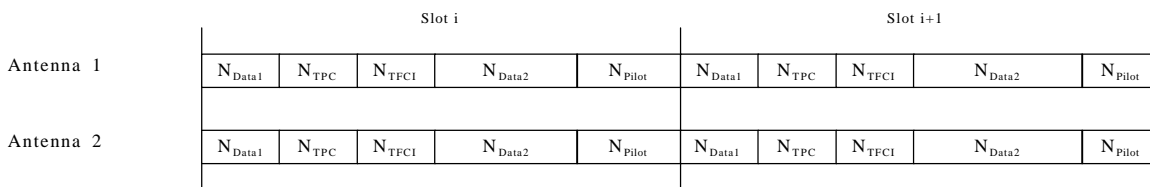

(b)

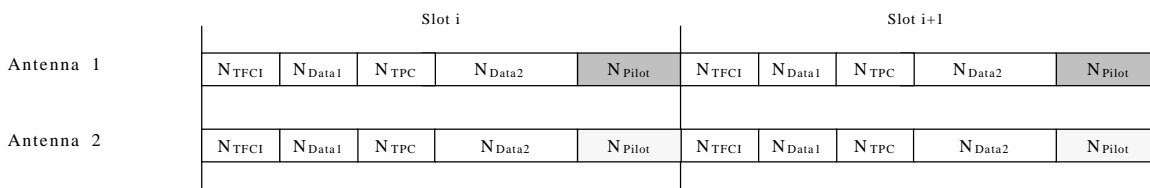

(a)

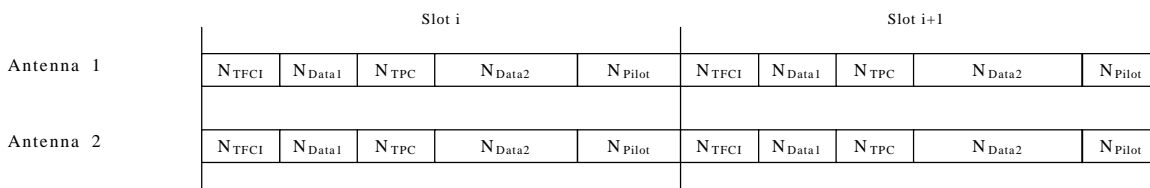

(b)

**Figure 12: Slot structures for downlink dedicated physical channel diversity transmission. Structure (a) is used in closed loop mode 1. Structure (b) is used in closed loop mode 2. Different shading of the pilots indicate orthogonality of the patterns**

### 5.3.2.3 DL-DPCCH for CPCH

The spreading factor for the UL-DPCCH (message control part ) is 256. The spreading factor for the DL-DPCCH (message control part) is 512. The following table 15 shows the DL-DPCCH fields (message control part) which are identical to the first row of table 11 in section 5.3.2.