

<h2 style="margin: 0;">CHANGE REQUEST</h2>		<small>Please see embedded help file at the bottom of this page for instructions on how to fill in this form correctly.</small>	
<b>25.211 CR 008</b>		Current Version: <b>V 3.0.0</b>	
<small>GSM (AA.BB) or 3G (AA.BBB) specification number ↑</small>		<small>↑ CR number as allocated by MCC support team</small>	
For submission to: <b>WG1 # 9</b>	for approval <input checked="" type="checkbox"/>	strategic <input type="checkbox"/>	<small>(for SMG use only)</small>
<small>list expected approval meeting # here ↑</small>	for information <input type="checkbox"/>	non-strategic <input type="checkbox"/>	

Form: CR cover sheet, version 2 for 3GPP and SMG    The latest version of this form is available from: <ftp://ftp.3gpp.org/Information/CR-Form-v2.doc>

**Proposed change affects:**    (U)SIM     ME     UTRAN / Radio     Core Network   
(at least one should be marked with an X)

**Source:**    Texas Instruments    **Date:**    8 Nov 1999

**Subject:**    Modifications to STTD text

**Work item:**    TS 25.211

<b>Category:</b>	F Correction <input type="checkbox"/> A Corresponds to a correction in an earlier release <input type="checkbox"/> B Addition of feature <input type="checkbox"/> C Functional modification of feature <input type="checkbox"/> D Editorial modification <input checked="" type="checkbox"/>	<b>Release:</b>	Phase 2 <input type="checkbox"/> Release 96 <input type="checkbox"/> Release 97 <input type="checkbox"/> Release 98 <input type="checkbox"/> Release 99 <input checked="" type="checkbox"/> Release 00 <input type="checkbox"/>
------------------	--	-----------------	--

(only one category shall be marked with an X)

**Reason for change:**    Better readability and notation for STTD description

**Clauses affected:**    5.3.1, 5.3.1.1.1, 5.3.2.1, 5.3.3.2.1, 5.3.3.5, 5.3.3.6, 5.3.3.7

<b>Other specs affected:</b>	Other 3G core specifications <input type="checkbox"/> Other GSM core specifications <input type="checkbox"/> MS test specifications <input type="checkbox"/> BSS test specifications <input type="checkbox"/> O&M specifications <input type="checkbox"/>	→ List of CRs: → List of CRs: → List of CRs: → List of CRs: → List of CRs:	
------------------------------	---	--	--

**Other comments:**

<----- double-click here for help and instructions on how to create a CR.

## 5.3 Downlink physical channels

### 5.3.1 Downlink Transmit Diversity

Table 10 summarizes the possible application of open and closed loop Transmit diversity modes on different downlink physical channels. Simultaneous use of STTD and closed loop modes on DPCH and PDSCH is not allowed.

**Table 10: Application of Tx diversity modes on downlink physical channels.**  
"X" – can be applied, "-" – not applied.

<u>Channel</u>	<u>Open loop mode</u>		<u>Closed loop Mode</u>
	<u>TSTD</u>	<u>STTD</u>	
<u>CPICH</u>	=	X	=
<u>P-CCPCH</u>	=	X	=
<u>SCH</u>	X	=	=
<u>S-CCPCH</u>	=	X	=
<u>DPCH</u>	=	X	X
<u>PICH</u>	=	X	=
<u>PDSCH (associated with DPCH)</u>	=	X	X
<u>AICH</u>	=	X	=

**Table 10: Application of Tx diversity modes on downlink physical channels.**

<b>Channel</b>	<b>Open loop mode</b>	<b>Closed loop mode</b>
CPICH	X	N/A
P-CCPCH	X	N/A
SCH	X	N/A
S-CCPCH	X	N/A
DPCH	X	X
PICH	X	N/A
PDSCH (associated with DPCH)	X	X
AICH	X	N/A

N/A = Not applied

X = Can be applied

#### 5.3.1.1 Open loop transmit diversity

##### 5.3.1.1.1 Space time block coding based transmit antenna diversity (STTD)

The open loop downlink transmit diversity employs a space time block coding based transmit diversity (STTD). The STTD encoding is optional in UTRAN. STTD support is mandatory at the UE. A block diagram of ~~the transmitter and a generic STTD encoder for channel bits  $b_0, b_1, b_2, b_3$  are shown in- Figure 7 and Figure 8 below.~~ Channel coding,

rate matching and interleaving is done as in the non-diversity mode. The bit  $b_i$  is real valued  $\{0\}$  for DTX bits and  $\{1, -1\}$  for all other channel bits.

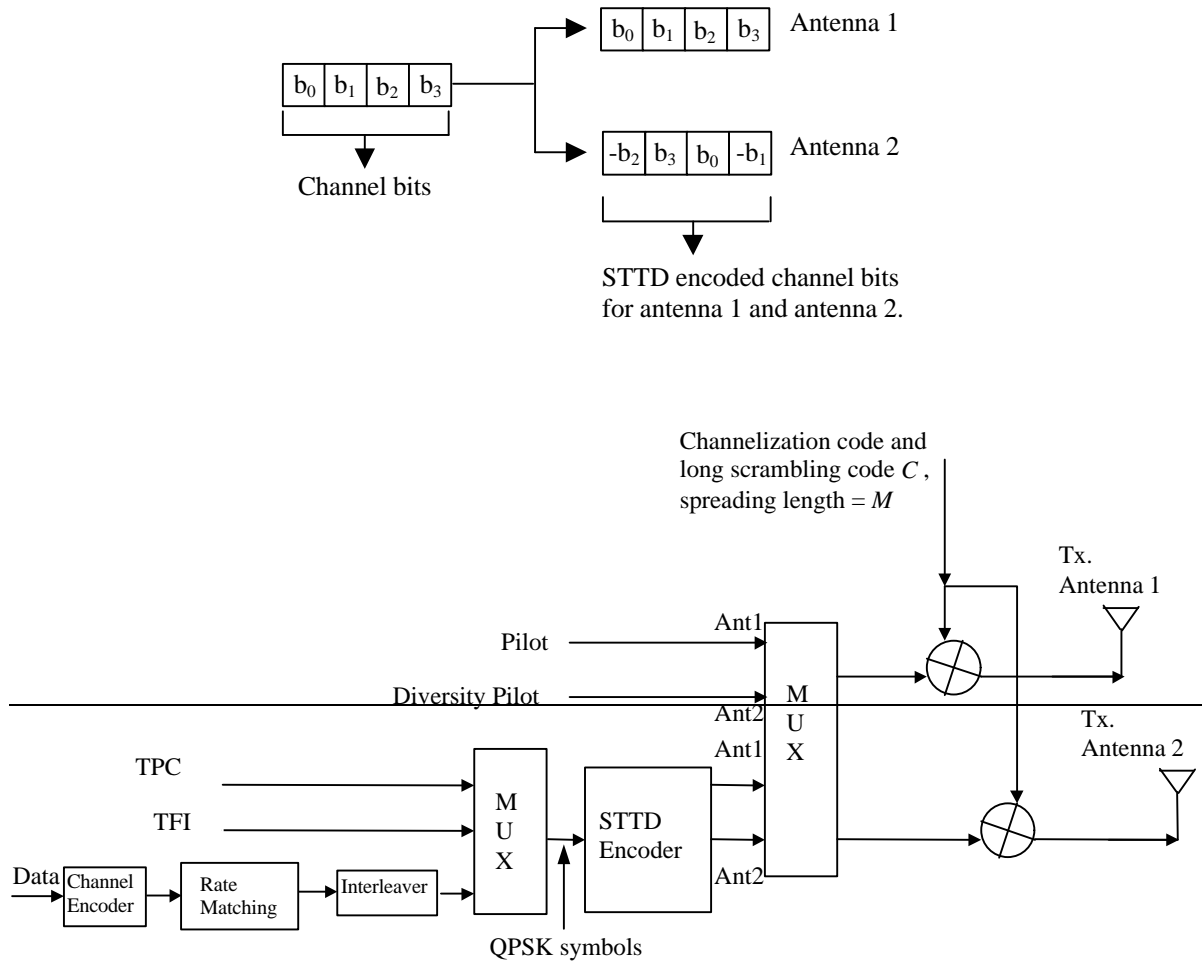

Figure 7: Generic bBlock diagram of the STTD encoder-transmitter (STTD).

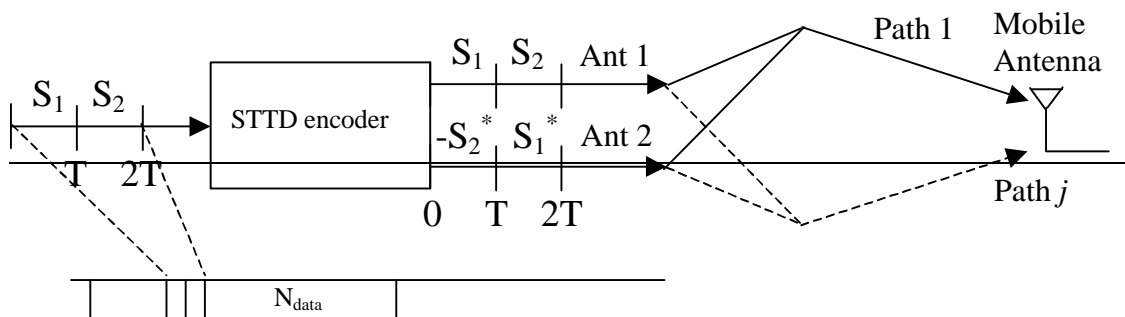

Figure 8: Block diagram of STTD encoder. The symbols  $S_1, S_2$  are QPSK or discontinuous transmission (DTX) symbols and  $T$  denotes the symbol time.

5.3.2.1 STTD for DPCH

The block diagrams shown in Figure 7 and Figure 8 are used to STTD encode the DPDCH, TPC and TFCI symbols. The pilot bit symbol pattern for the DPCH channel transmitted on the diversity antenna is given in Table 14. The shadowed part indicates pilot bits that are STTD encoded from the corresponding (shadowed) bits in Table 12. For the SF=256 DPCH, if there are only two dedicated pilot bits ( $N_{pilot} = 2$  in Tables 12 and 14), they are STTD encoded together with the last two bits (data or DTX) of the second data field (data2) of the slot. STTD encoding for the DPDCH, TPC, and TFCI fields is done as described in section 5.3.1.1.1. In the SF=512 DPCH, if there is only one dedicated pilot symbol, it is STTD encoded together with the last symbol (data or DTX) of the second data field (data2) of the slot. For the SF=512 DPCH, the the last two data bits in even numbered slots are STTD encoded together with the first two data bits in the following slot, except for slot #14 where the two last data bits are not STTD encoded and instead transmitted with equal power from both the antennas, see Figure 12.

last odd data symbol in every radio frame is not STTD encoded and the same symbol is transmitted with equal power from the two antennas.

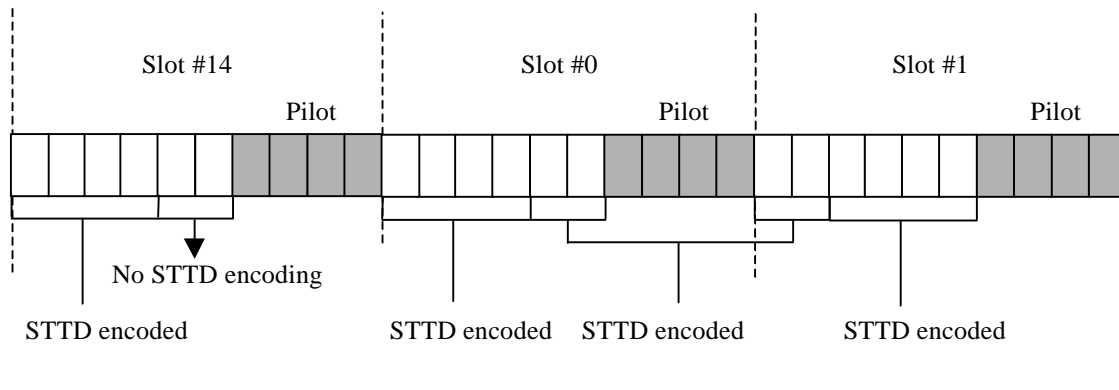

Figure 12: STTD encoding for SF = 512 DPCH.

Table 14: Pilot pattern of the DPCH channel for the diversity antenna using STTD.

Symbol #	$N_{pilot}=2$			$N_{pilot} = 4$				$N_{pilot} = 8$								$N_{pilot} = 16$							
	0	0	1	0	1	2	3	0	1	2	3	4	5	6	7	0	1	2	3	4	5	6	7
Slot #0	01	01	10	11	00	00	10	11	00	00	10	11	00	00	10	11	00	00	10	11	00	00	10
1	10	10	10	11	00	00	01	11	00	00	01	11	10	00	10	11	00	00	01	11	00	00	10
2	11	11	10	11	11	00	00	11	11	00	00	11	10	00	11	11	00	00	01	11	00	00	11
3	10	10	10	11	10	00	01	11	10	00	01	11	00	00	11	11	00	00	01	11	00	00	10
4	00	00	10	11	11	00	11	11	11	00	11	11	01	00	10	11	00	00	01	11	00	00	10
5	01	01	10	11	00	00	10	11	00	00	10	11	11	00	00	11	00	00	01	11	00	00	10
6	01	01	10	11	10	00	10	11	10	00	10	11	01	00	11	11	00	00	01	11	00	00	11
7	00	00	10	11	10	00	11	11	10	00	11	11	10	00	11	11	00	00	01	11	00	00	11
8	11	11	10	11	00	00	00	11	00	00	00	11	01	00	01	11	00	00	01	11	00	00	10
9	01	01	10	11	01	00	10	11	01	00	10	11	01	00	10	11	00	00	01	11	00	00	10
10	11	11	10	11	11	00	00	11	11	00	00	11	00	00	10	11	00	00	01	11	00	00	10
11	00	00	10	11	01	00	11	11	01	00	11	11	00	00	10	11	00	00	01	11	00	00	10
12	00	00	10	11	10	00	11	11	10	00	11	11	00	00	10	11	00	00	01	11	00	00	10
13	10	10	10	11	01	00	01	11	01	00	01	11	00	00	10	11	00	00	01	11	00	00	10
14	10	10	10	11	01	00	01	11	01	00	01	11	00	00	10	11	00	00	01	11	00	00	10

### 5.3.3.2.1 Primary CCPCH structure with STTD encoding

In case the diversity antenna is present in UTRAN and the P-CCPCH is to be transmitted using open loop transmit diversity, the data bits of the P-CCPCH are STTD encoded as given in section 5.3.1.1.1, ~~Figure 7 and Figure 8~~. The last two data bits in even numbered slots are STTD encoded together with the first two data bits in the following slot, except for slot #14 where the two last data bits are not STTD encoded and instead transmitted with equal power from both the antennas, see Figure 16. The last odd data symbol in every frame (10 ms) is not STTD encoded and the same symbol is transmitted with equal power from the two antennas. Higher layers signal whether STTD encoding is used for the P-CCPCH or not. In addition, higher layer signalling indicates the presence/absence of STTD encoding on P-CCPCH, by modulating the SCH. During power on and hand over between cells the UE determines the presence of STTD encoding on the P-CCPCH, by either receiving the higher layer message, by demodulating the SCH channel or by a combination of the above two schemes.

~~The STTD encoding for the data symbols of the slots 0 and 1 of a P-CCPCH frame is given in the Figure 16. The same procedure is used for the data symbols of slots 2 and 3, 4 and 5 and henceforth, respectively.~~

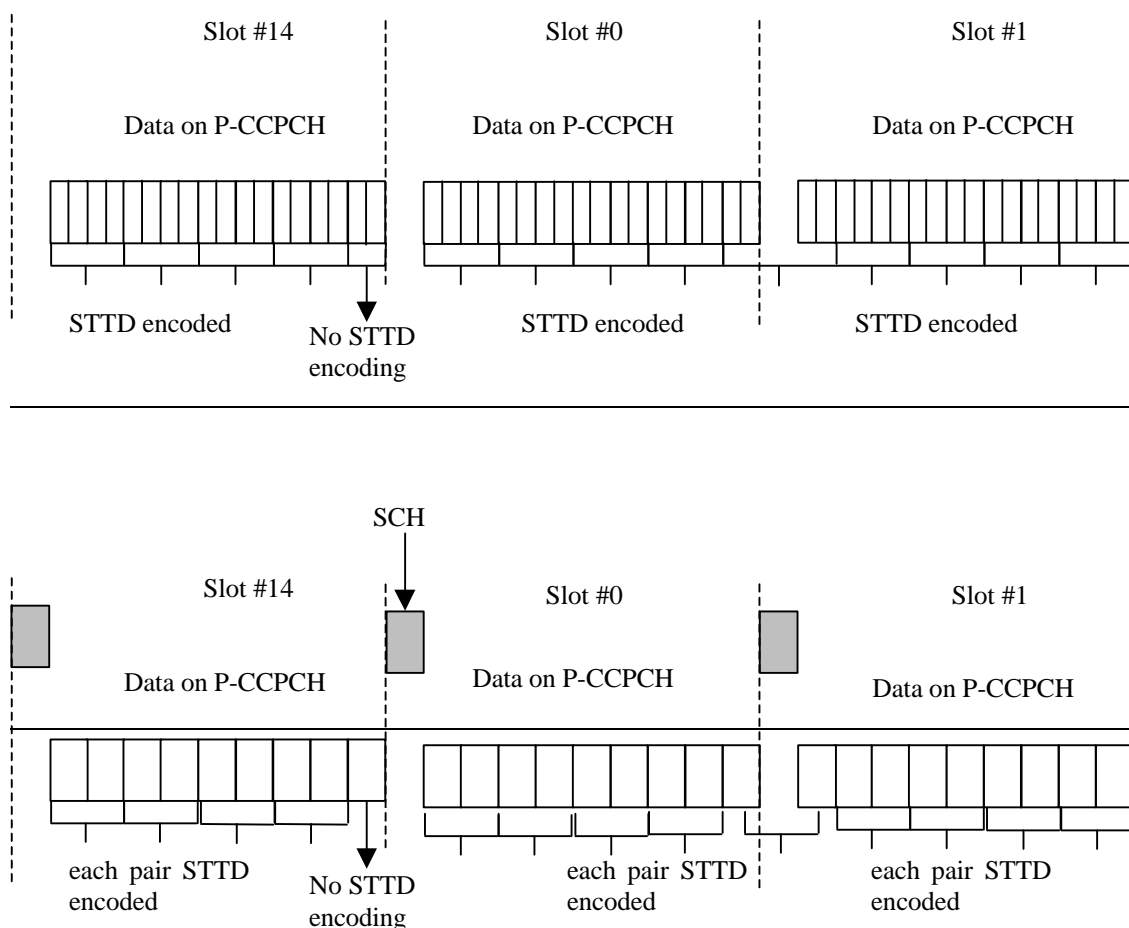
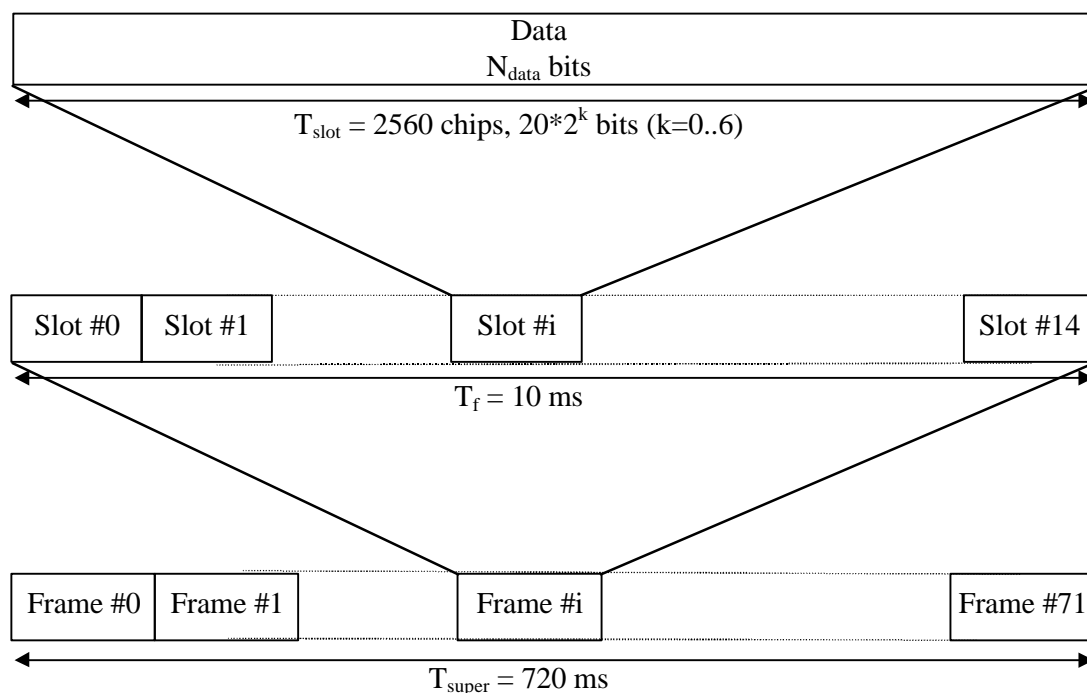

**Figure 16: STTD encoding for the data bits symbols of the P-CCPCH.**

### 5.3.3.5 Physical Downlink Shared Channel (PDSCH)

The Physical Downlink Shared Channel (PDSCH), used to carry the Downlink Shared Channel (DSCH), is shared by users based on code multiplexing. As the DSCH is always associated with a DCH, the PDSCH is always associated with a downlink DPCH.

The frame and slot structure of the PDSCH are shown on Figure 20.



**Figure 20: Frame structure for the PDSCH.**

To indicate for UE that there is data to decode on the DSCH, two signalling methods are possible, either using the TFCI field, or higher layer signalling.

The PDSCH transmission with associated DPCH is a special case of multicode transmission. The PDSCH and DPCH do not have necessary the same spreading factors and for PDSCH the spreading factor may vary from frame to frame. The relevant Layer 1 control information is transmitted on the DPCCH part of the associated DPCH, the PDSCH does not contain physical layer information. The channel bit and symbol rates for PDSCH are given in Table 20.

For PDSCH the allowed spreading factors may vary from 256 to 4.

If the spreading factor and other physical layer parameters can vary on a frame-by-frame basis, the TFCI shall be used to inform the UE what are the instantaneous parameters of PDSCH including the channelisation code from the PDSCH OVSF code tree.

A DSCH may be mapped to multiple parallel PDSCHs as well, as negotiated at higher layer prior to starting data transmission. In such a case the parallel PDSCHs shall be operated with frame synchronization between each other.

**Table 20: PDSCH fields.**

Slot format #i	Channel Bit Rate (kbps)	Channel Symbol Rate (ksps)	SF	Bits/ Frame	Bits/ Slot	N <sub>data</sub>
0	30	15	256	300	20	20
1	60	30	128	600	40	40
2	120	60	64	1200	80	80
3	240	120	32	2400	160	160
4	480	240	16	4800	320	320
5	960	480	8	9600	640	640
6	1920	960	4	19200	1280	1280

When transmit diversity is employed for the PDSCH, STTD encoding is used on the data bits as described in section 5.3.1.1.1.

### 5.3.3.6 Acquisition Indication Channel (AICH)

The Acquisition Indicator channel (AICH) is a physical channel used to carry Acquisition Indicators (AI). Acquisition Indicator AI<sub>i</sub> corresponds to signature *i* on the PRACH or PCPCH. Note that for PCPCH, the AICH is either in response to an access preamble or a CD preamble. The corresponding to the access preamble AICH is the AP-AICH and the corresponding to the CD preamble AICH is the CD-AICH. The AP-AICH and CD-AICH use different channelization codes, see further [4] Section 4.3.3.2.

Figure 21 illustrates the frame structure of the AICH. Two AICH frames of total length 20 ms consist of 15 *access slots* (AS), each of length 20 symbols (5120 chips). Each access slot consists of two parts, an *Acquisition-Indicator* (AI) part and an empty part.

The AI-part of the access slot is generated as described in [4]. The empty part of the access slot consists of 4 zeros. The phase reference for the AICH is the CPICH.

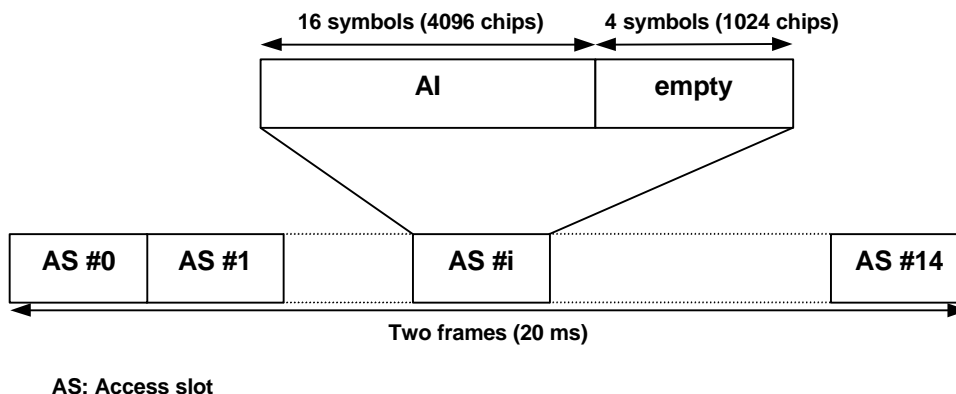

**Figure21 : Structure of Acquisition Indicator Channel (AICH).**

When transmit diversity is employed for the AICH, STTD encoding is used on the data bits as described in section 5.3.1.1.1.

### 5.3.3.7 Page Indication Channel (PICH)

The Page Indicator Channel (PICH) is a fixed rate (SF=256) physical channel used to carry the Page Indicators (PI). The PICH is always associated with an S-CCPCH to which a PCH transport channel is mapped.

Figure 22 illustrates the frame structure of the PICH. One PICH frame of length 10 ms consists 300 bits. Of these, 288 bits are used to carry Page Indicators. The remaining 12 bits are not used.

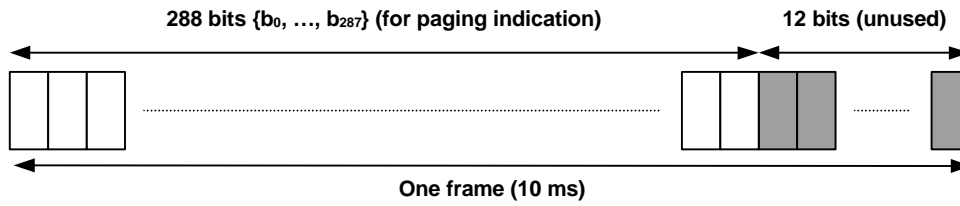

**Figure 22: Structure of Page Indicator Channel (PICH).**

N Page Indicators {PI<sub>0</sub>, ..., PI<sub>N-1</sub>} are transmitted in each PICH frame, where N=18, 36, 72, or 144. The mapping from {PI<sub>0</sub>, ..., PI<sub>N-1</sub>} to the PICH bits {b<sub>0</sub>, ..., b<sub>287</sub>} are according to Table 21.

**Table 21: Mapping of Page Indicators (PI) to PICH bits.**

Number of PI per frame (N)	PI <sub>i</sub> = 1	PI <sub>i</sub> = 0
N=18	{b <sub>16i</sub> , ..., b <sub>16i+15</sub> } = {1,1,...,1}	{b <sub>16i</sub> , ..., b <sub>16i+15</sub> } = {0,0,...,0}
N=36	{b <sub>8i</sub> , ..., b <sub>8i+7</sub> } = {1,1,...,1}	{b <sub>8i</sub> , ..., b <sub>8i+7</sub> } = {0,0,...,0}
N=72	{b <sub>4i</sub> , ..., b <sub>4i+3</sub> } = {1, 1,...,1}	{b <sub>4i</sub> , ..., b <sub>4i+3</sub> } = {0, 0,...,0}
N=144	{b <sub>2i</sub> , b <sub>2i+1</sub> } = {1,1}	{b <sub>2i</sub> , b <sub>2i+1</sub> } = {0,0}

If a Paging Indicator in a certain frame is set to "1" it is an indication that UEs associated with this Page Indicator should read the corresponding frame of the associated S-CCPCH.

When transmit diversity is employed for the PICH, STTD encoding is used on the PICH bits as described in section 5.3.1.1.1.