

Source: Siemens
Title: Text Proposal: Update of TS 25.222
Document for: Approval

Introduction

During the discussion on the WG1 reflector it turned out that some corrections and clarification regarding multiplexing are required mainly in the section rate matching to avoid any misunderstanding and ambiguities.

This text proposal deals with those items which are relevant for TDD based on a proposal distributed on the mail reflector by Mitsubishi [1].

Some additional editorial corrections were included to guarantee a high quality of the specification [2] before upgrading it to version V3.0.0

However, according to the agreement made during last WG1 meeting in Hanover no new change regarding the technical content is proposed.

Text proposal

In the annex an updated version of the specification TS25.222 is provided. Beside editorial correction the following changes with respect to the version 2.2.0 are included:

Section 6.2.7, 'Rate matching':

- E_{ini} is replaced by e_{ini}
- For clarification the new parameters e_{plus} and e_{minus} have been introduced according to a proposal from Mitsubishi
- In section 6.2.7.1 the meaning of N_{data} for TDD was clarified
- The special case $\Delta N_{i,j}=0$ now is considered
- The determination of the parameters needed for the rate matching has been reordered. Now the same structure for convolutional as for turbo coding is applied.

Section 6.3, 'Coding for layer 1 control':

- The subsection 6.3.2 'Operation of TFCI in Split mode' is deleted. This section was already removed in the original TDD text proposal for the new TFCI coding scheme provided by Samsung during the Hanover meeting and included again due to some concerns from Siemens. In the meantime it turned out that this mode is no longer needed.

[1] Mail on WG1 reflector from 22th of September titled 'RM some corrections', Source: Mitsubishi

[2] TSG RAN WG1, TS 25.222, 'Multiplexing and channel coding (TDD)'

[3] TSG RAN WG1 #7 (99)b60, 'New optimal coding for extended TFCI...', Source: Samsung

TS 25.222 V2.2.0 1999-09

**3rd Generation Partnership Project (3GPP);
Technical Specification Group (TSG)
Radio Access Network (RAN);
Working Group 1 (WG1);
Multiplexing and channel coding (TDD);**



Reference

<Workitem>

Keywords

<keyword[, keyword]>

3GPP

Postal address

Office address

Internet

<http://www.3gpp.org>

Copyright Notification

Reproduction is only permitted for the purpose of standardization work undertaken within 3GPP.
The copyright and the foregoing restrictions extend to reproduction in all media.

© 3GPP 1999.
All rights reserved.

Contents

1	Intellectual Property Rights.....	4
2	Foreword.....	4
3	Scope.....	4
4	References.....	4
5	Definitions, symbols and abbreviations	5
5.1	Definitions.....	5
5.2	Symbols.....	5
5.3	Abbreviations	5
6	Multiplexing, channel coding and interleaving	8
6.1	General.....	8
6.2	Transport channel coding/multiplexing	8
6.2.1	Error detection	10
6.2.1.1	CRC calculation.....	10
6.2.1.2	Relation between input and output of the Cyclic Redundancy Check	10
6.2.2	Transport block concatenation and code block segmentation	10
6.2.2.1	Concatenation of transport blocks	10
6.2.2.2	Code block segmentation	11
6.2.3	Channel coding	11
6.2.3.1	Convolutional Coding	12
6.2.3.2	Turbo coding	13
6.2.3.2.1	Turbo coder	13
6.2.3.2.2	Trellis termination in turbo code.....	14
6.2.3.2.3	Turbo code internal interleaver.....	14
6.2.4	Radio frame size equalisation	17
6.2.5	1 st interleaving	17
6.2.6	Radio frame segmentation	18
6.2.7	Rate matching	19
6.2.7.1	Determination of rate matching parameters.....	20
6.2.7.2	Bit separation for rate matching.....	22
6.2.7.3	Rate matching pattern determination	23
6.2.8	TrCH multiplexing.....	<u>24</u> <u>24</u> <u>23</u>
6.2.9	Physical channel segmentation	24
6.2.10	2 nd interleaving.....	<u>25</u> <u>24</u>
6.2.10.1	Frame related 2 nd interleaving.....	<u>25</u> <u>24</u>
6.2.10.2	Timeslot related 2 nd interleaving	<u>26</u> <u>25</u>
6.2.11	Physical channel mapping	<u>27</u> <u>26</u>
6.2.11.1	Mapping scheme after frame related 2 nd interleaving.....	<u>27</u> <u>26</u>
6.2.11.2	Mapping scheme after timeslot related 2 nd interleaving	<u>27</u> <u>27</u> <u>26</u>
6.2.12	Multiplexing of different transport channels onto one CCTrCH, and mapping of one CCTrCH onto physical channels	<u>27</u> <u>27</u> <u>26</u>
6.2.12.1	Allowed CCTrCH combinations for one UE.....	<u>28</u> <u>27</u>
6.2.12.1.1	Allowed CCTrCH combinations on the uplink.....	<u>28</u> <u>27</u>
6.2.12.1.2	Allowed CCTrCH combinations on the downlink	<u>28</u> <u>28</u> <u>27</u>
6.2.13	Transport format detection	<u>28</u> <u>28</u> <u>27</u>
6.2.13.1	Blind transport format detection.....	<u>28</u> <u>28</u> <u>27</u>
6.2.13.2	Explicit transport format detection based on TFCI	28
6.2.13.2.1	Transport Format Combination Indicator (TFCI).....	28
6.3	Coding for layer 1 control.....	28
6.3.1	Coding of transport format combination indicator (TFCI).....	28
6.3.1.1	Default TFCI word.....	<u>29</u> <u>28</u>
6.3.1.2	Coding of short TFCI lengths.....	29
6.3.2	Operation of Transport-format-combination indicator (TFCI) in Split Mode.....	<u>30</u> <u>29</u>
6.3.3	Coding of Paging Indicator (PI).....	30

6.3.4	Coding of Transmit Power Control (TPC)	3130
7	History	3231

1 Intellectual Property Rights

<Editor's note: this section will be completed when an official format for the document is agreed>

2 Foreword

This Technical Specification has been produced by the 3GPP.

The contents of the present document are subject to continuing work within the TSG and may change following formal TSG approval. Should the TSG modify the contents of this TS, it will be re-released by the TSG with an identifying change of release date and an increase in version number as follows:

Version 3.y.z

where:

x the first digit:

- 1) presented to TSG for information;
- 2) presented to TSG for approval;
- 3) Indicates TSG approved document under change control.

Y the second digit is incremented for all changes of substance, i.e. technical enhancements, corrections, updates, etc.

z the third digit is incremented when editorial only changes have been incorporated in the specification;

3 Scope

This 3GPP Report describes multiplexing, channel coding and interleaving for UTRA Physical Layer TDD mode.

Text without revision marks has been approved in the previous TSG-RAN WG1 meetings, while text with revision marks is subject to approval.

4 References

The following documents contain provisions which, through reference in this text, constitute provisions of the present document.

- [1] TS 25.202-~~(V1.0.0)~~: "UE capabilities"
- [2] TS 25.211-~~(V1.0.0)~~: "Transport channels and physical channels (FDD)"
- [3] TS 25.212-~~(V1.0.0)~~: "Multiplexing and channel coding (FDD)"
- [4] TS 25.213-~~(V1.0.0)~~: "Spreading and modulation (FDD)"
- [5] TS 25.214-~~(V1.0.0)~~: "Physical layer procedures (FDD)"

- [6] TS 25.215: “Physical layer – Measurements (FDD)”
- ~~[6]~~[7] TS 25.221-(V1.0.0): “Transport channels and physical channels (TDD)”
- ~~[7]~~[8] TS 25.222-(V1.0.0): “Multiplexing and channel coding (TDD)”
- ~~[8]~~[9] TS 25.223-(V1.0.0): “Spreading and modulation (TDD)”
- ~~[9]~~[10] TS 25.224-(V1.0.0): “Physical layer procedures (TDD)”
- ~~[10]~~[11] TS 25.23425-(V1.0.0): “Physical layer – Measurements (TDD)”
- ~~[11]~~[12] TS S2.01-(V1.0.0): “Radio Interface Protocol Architecture”

5 Definitions, symbols and abbreviations

5.1 Definitions

For the purposes of the present document, the following definitions apply:

<defined term>: <definition>.

5.2 Symbols

For the purposes of the present document, the following symbols apply:

$\lceil x \rceil$ round towards ∞ , i.e. integer such that $x - 1 < \lceil x \rceil < x + 1$

$\lfloor x \rfloor$ round towards $-\infty$, i.e. integer such that $x - 1 < \lfloor x \rfloor \leq x$

$|x|$ absolute value of x

Unless otherwise is explicitly stated when the symbol is used, the meaning of the following symbols are:

i TrCH number

j TFC number

k Bit number

l TF number

m Transport block number

n Radio frame number

p PhCH number

r Code block number

I Number of TrCHs in a CCTrCH.

C_i Number of code blocks in one TTI of TrCH i .

F_i Number of radio frames in one TTI of TrCH i .

M_i Number of transport blocks in one TTI of TrCH i .

P Number of PhCHs used for one CCTrCH.

PL Puncturing Limit for the uplink. Signalled from higher layers

RM_i Rate Matching attribute for TrCH i . Signalled from higher layers.

5.3 Abbreviations

ARQ Automatic Repeat on Request

BCH Broadcast Channel

BER Bit Error Rate

BPSK Binary Phase Shift Keying

BS Base Station

BSS	Base Station Subsystem
CA	Capacity Allocation
CAA	Capacity Allocation Acknowledgement
CBR	Constant Bit Rate
CCCH	Common Control Channel
CCTrCH	Coded Composite Transport Channel
CD	Capacity Deallocation
CDA	Capacity Deallocation Acknowledgement
CDMA	Code Division Multiple Access
CTDMA	Code Time Division Multiple Access
CRC	Cyclic Redundancy Check
DCA	Dynamic Channel Allocation
DCCH	Dedicated Control Channel
DL	Downlink
DRX	Discontinuous Reception
DSCH	Downlink Shared Channel
DTX	Discontinuous Transmission
FACH	Forward Access Channel
FDD	Frequency Division Duplex
FDMA	Frequency Division Multiple Access
FEC	Forward Error Control
FER	Frame Error Rate
GF	Galois Field
HCS	Hierarchical Cell Structure
JD	Joint Detection
L1	Layer 1
L2	Layer 2
LLC	Logical Link Control
MA	Multiple Access
MAC	Medium Access Control
MAHO	Mobile Assisted Handover
MO	Mobile Originated
MOHO	Mobile Originated Handover
MS	Mobile Station
MT	Mobile Terminated
NRT	Non-Real Time
PC	Power Control
PCCC	Parallel Concatenated Convolutional Code
PCH	Paging Channel
QoS	Quality of Service
QPSK	Quaternary Phase Shift Keying
RACH	Random Access Channel
RF	Radio Frequency
RLC	Radio Link Control
RRC	Radio Resource Control
RRM	Radio Resource Management
RT	Real Time
RU	Resource Unit

SCCC	Serial Concatenated Convolutional Code
SCH	Synchronization Channel
SDCCH	Stand-alone Dedicated Control Channel
SFN	System Frame Number
SNR	Signal to Noise Ratio
SP	Switching Point
TCH	Traffic channel
TDD	Time Division Duplex
TDMA	Time Division Multiple Access
TFCI	Transport Format Combination Indicator
TrBk	Transport Block
TrCH	Transport Channel
UL	Uplink
UMTS	Universal Mobile Telecommunications System
VBR	Variable Bit Rate

6 Multiplexing, channel coding and interleaving

6.1 General

Data stream from/to MAC and higher layers (Transport block / Transport block set) is encoded/decoded to offer transport services over the radio transmission link. Channel coding scheme is a combination of error detection, error correcting (including rate matching), and interleaving and transport channels mapping onto/splitting from physical channels.

In the UTRA-TDD mode, the total number of basic physical channels (a certain time slot one spreading code on a certain carrier frequency) per frame is given by the maximum number of time slots which is 15 and the maximum number of CDMA codes per time slot.

6.2 Transport channel coding/multiplexing

Figure 6-1 illustrates the overall concept of transport-channel coding and multiplexing. Data arrives to the coding/multiplexing unit in form of transport block sets, once every transmission time interval. The transmission time interval is transport-channel specific from the set {10 ms, 20 ms, 40 ms, 80 ms}.

The following coding/multiplexing steps can be identified:

- Add CRC to each transport block (see section 6.2.1)
- TrBk concatenation / Code block segmentation (see section 6.2.2)
- Channel coding (see section 6.2.3)
- Radio frame size equalization (see section 6.2.4)
- Interleaving (two steps, see sections 6.2.5 and 6.2.10)
- Radio frame segmentation (6.2.6)
- Rate matching (see section 6.2.7)
- Multiplexing of transport channels (see section 6.2.8)
- Physical channel segmentation (see section 6.2.9)
- Mapping to physical channels (see section 6.2.11)

The coding/multiplexing steps for uplink and downlink are shown in Figure 6-1.

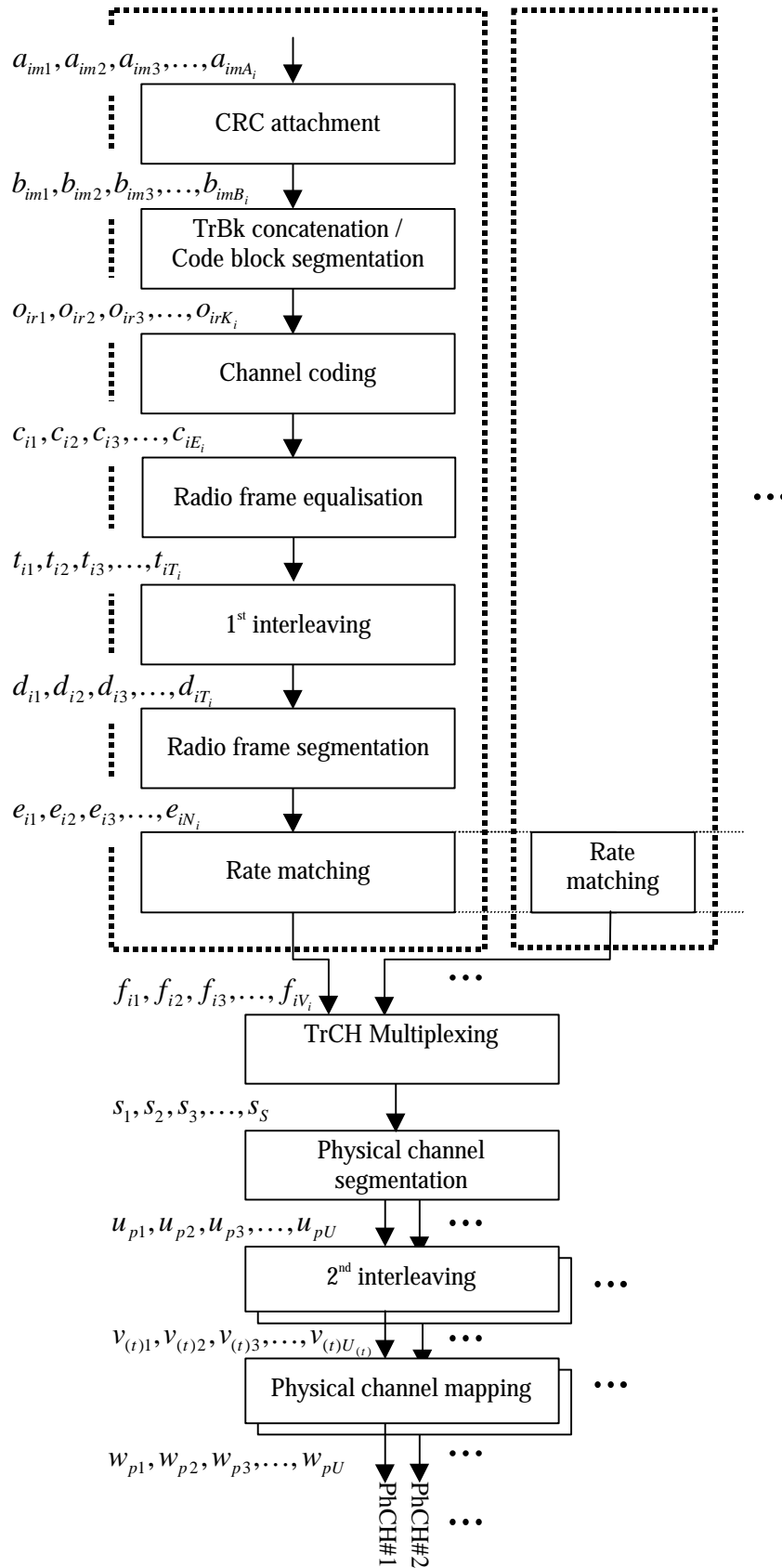

Figure 6–1. Transport channel multiplexing structure for uplink and downlink

Primarily, transport channels are multiplexed as described above, i.e. into one data stream mapped on one or several physical channels. However, an alternative way of multiplexing services is to use multiple CCTrCHs (Coded

Composite Transport Channels), which corresponds to having several parallel multiplexing chains as in Figure 6-1, resulting in several data streams, each mapped to one or several physical channels.

6.2.1 Error detection

Error detection is provided on transport blocks through a Cyclic Redundancy Check. The CRC is 24, 16, 8 or 0 bits and it is signalled from higher layers what CRC length that should be used for each transport channel.

6.2.1.1 CRC calculation

The entire transport block is used to calculate the CRC parity bits for each transport block. The parity bits are generated by one of the following cyclic generator polynomials:

$$g_{\text{CRC24}}(D) = D^{24} + D^{23} + D^6 + D^5 + D + 1$$

$$g_{\text{CRC16}}(D) = D^{16} + D^{12} + D^5 + 1$$

$$g_{\text{CRC8}}(D) = D^8 + D^7 + D^4 + D^3 + D + 1$$

Denote the bits in a transport block delivered to layer 1 by $a_{im1}, a_{im2}, a_{im3}, \dots, a_{imA_i}$, and the parity bits by

$p_{im1}, p_{im2}, p_{im3}, \dots, p_{imL_i}$. A_i is the length of a transport block of TrCH i , m is the transport block number, and L_i is 24, 16, 8, or 0 depending on what is signalled from higher layers.

The encoding is performed in a systematic form, which means that in GF(2), the polynomial

$$a_{im1}D^{A_i+23} + a_{im2}D^{A_i+22} + \dots + a_{imA_i}D^{24} + p_{im1}D^{23} + p_{im2}D^{22} + \dots + p_{im23}D^1 + p_{im24}$$

yields a remainder equal to 0 when divided by $g_{\text{CRC24}}(D)$, polynomial

$$a_{im1}D^{A_i+15} + a_{im2}D^{A_i+14} + \dots + a_{imA_i}D^{16} + p_{im1}D^{15} + p_{im2}D^{14} + \dots + p_{im15}D^1 + p_{im16}$$

yields a remainder equal to 0 when divided by $g_{\text{CRC16}}(D)$, and polynomial

$$a_{im1}D^{A_i+7} + a_{im2}D^{A_i+6} + \dots + a_{imA_i}D^8 + p_{im1}D^7 + p_{im2}D^6 + \dots + p_{im7}D^1 + p_{im8}$$

yields a remainder equal to 0 when divided by $g_{\text{CRC8}}(D)$.

6.2.1.2 Relation between input and output of the Cyclic Redundancy Check

The bits after CRC attachment are denoted by $b_{im1}, b_{im2}, b_{im3}, \dots, b_{imB_i}$, where $B_i = A_i + L_i$. The relation between a_{imk} and b_{imk} is:

$$b_{imk} = a_{imk} \quad k = 1, 2, 3, \dots, A_i$$

$$b_{imk} = p_{im(L_i+1-(k-A_i))} \quad k = A_i + 1, A_i + 2, A_i + 3, \dots, A_i + L_i$$

6.2.2 Transport block concatenation and code block segmentation

All transport blocks in a TTI are serially concatenated. If the number of bits in a TTI is larger than Z , then code block segmentation is performed after the concatenation of the transport blocks. The maximum size of the code blocks depend on if convolutional or turbo coding is used for the TrCH.

6.2.2.1 Concatenation of transport blocks

The bits input to the transport block concatenation are denoted by $b_{im1}, b_{im2}, b_{im3}, \dots, b_{imB_i}$ where i is the TrCH number, m is the transport block number, and B_i is the number of bits in each block (including CRC). The number of transport blocks on TrCH i is denoted by M_i . The bits after concatenation are denoted by $x_{i1}, x_{i2}, x_{i3}, \dots, x_{iX_i}$, where i is the TrCH number and $X_i = M_i B_i$. They are defined by the following relations:

$$x_{ik} = b_{i1k} \quad k = 1, 2, \dots, B_i$$

$$x_{ik} = b_{i,2,(k-B_i)} \quad k = B_i + 1, B_i + 2, \dots, 2B_i$$

$$x_{ik} = b_{i,3,(k-2B_i)} \quad k = 2B_i + 1, 2B_i + 2, \dots, 3B_i$$

...

$$x_{ik} = b_{i,M_i,(k-(M_i-1)B_i)} \quad k = (M_i - 1)B_i + 1, (M_i - 1)B_i + 2, \dots, M_iB_i$$

6.2.2.2 Code block segmentation

< Note: It is assumed that filler bits are set to 0 >

Segmentation of the bit sequence from transport block concatenation is performed if $X_i > Z$. The code blocks after segmentation are of the same size. The number of code blocks on TrCH i is denoted by C_i . If the number of bits input to the segmentation, X_i , is not a multiple of C_i , filler bits are added to the last block. The filler bits are transmitted and they are always set to 0. The maximum code block sizes are:

convolutional coding: $Z = 512 - K_{tail}$

turbo coding: $Z = 5120 - K_{tail}$

The bits output from code block segmentation are denoted by $o_{ir1}, o_{ir2}, o_{ir3}, \dots, o_{irK_i}$, where i is the TrCH number, r is the code block number, and K_i is the number of bits.

Number of code blocks: $C_i = \lceil X_i / Z \rceil$

Number of bits in each code block: $K_i = \lceil X_i / C_i \rceil$

Number of filler bits: $Y_i = C_i K_i - X_i$

If $X_i \nmid Z$, then $o_{ilk} = x_{ik}$, and $K_i = X_i$.

If $X_i \nmid Z$, then

$$o_{i1k} = x_{ik} \quad k = 1, 2, \dots, K_i$$

$$o_{i2k} = x_{i,(k+K_i)} \quad k = 1, 2, \dots, K_i$$

$$o_{i3k} = x_{i,(k+2K_i)} \quad k = 1, 2, \dots, K_i$$

...

$$o_{iC_i k} = x_{i,(k+(C_i-1)K_i)} \quad k = 1, 2, \dots, K_i - Y_i$$

$$o_{iC_i k} = 0 \quad k = (K_i - Y_i) + 1, (K_i - Y_i) + 2, \dots, K_i$$

6.2.3 Channel coding

Code blocks are delivered to the channel coding block. They are denoted by $o_{ir1}, o_{ir2}, o_{ir3}, \dots, o_{irK_i}$, where i is the TrCH number, r is the code block number, and K_i is the number of bits in each code block. The number of code blocks on TrCH i is denoted by C_i . After encoding the bits are denoted by $x_{ir1}, x_{ir2}, x_{ir3}, \dots, x_{irX_i}$. The encoded blocks are serially multiplexed so that the block with lowest index r is output first from the channel coding block. The bits output are denoted by $c_{i1}, c_{i2}, c_{i3}, \dots, c_{iE_i}$, where i is the TrCH number and $E_i = C_i X_i$. The output bits are defined by the following relations:

$$c_{ik} = x_{i1k} \quad k = 1, 2, \dots, X_i$$

$$C_{ik} = x_{i,2,(k-X_i)} \quad k = X_i + 1, X_i + 2, \dots, 2X_i$$

$$C_{ik} = x_{i,3,(k-2X_i)} \quad k = 2X_i + 1, 2X_i + 2, \dots, 3X_i$$

...

$$C_{ik} = x_{i,C_i,(k-(C_i-1)X_i)} \quad k = (C_i - 1)X_i + 1, (C_i - 1)X_i + 2, \dots, C_iX_i$$

The relation between O_{irk} and x_{irk} and between K_i and X_i is dependent on the channel coding scheme.

The following channel coding schemes can be applied to transport channels.

- Convolutional coding
- Turbo coding
- No channel coding

Table 6.2.3-1 Error Correction Coding Parameters

Transport channel type	Coding scheme	Coding rate
BCH	Convolutional code	1/2
PCH		
FACH		
RACH		
DCH		1/3, 1/2, or no coding
DCH	Turbo code	1/3, or no coding

<Note: Removal of 1/2 Turbo code rate is a working assumption of WG1.>

6.2.3.1 Convolutional Coding

- Constraint length $K=9$. Coding rates 1/2 and 1/3.
- The configuration of the convolutional coder is presented in Fig. 6-2.
- The output from the convolutional coder shall be done in the order output0, output1,output2, output0, output1,..., output2. (When coding rate is 1/2, output is done up to output 1).
- The initial value of the shift register of the coder shall be "all 0".
- $K-1$ tail bits (value 0) shall be added to the end of the code block before encoding.

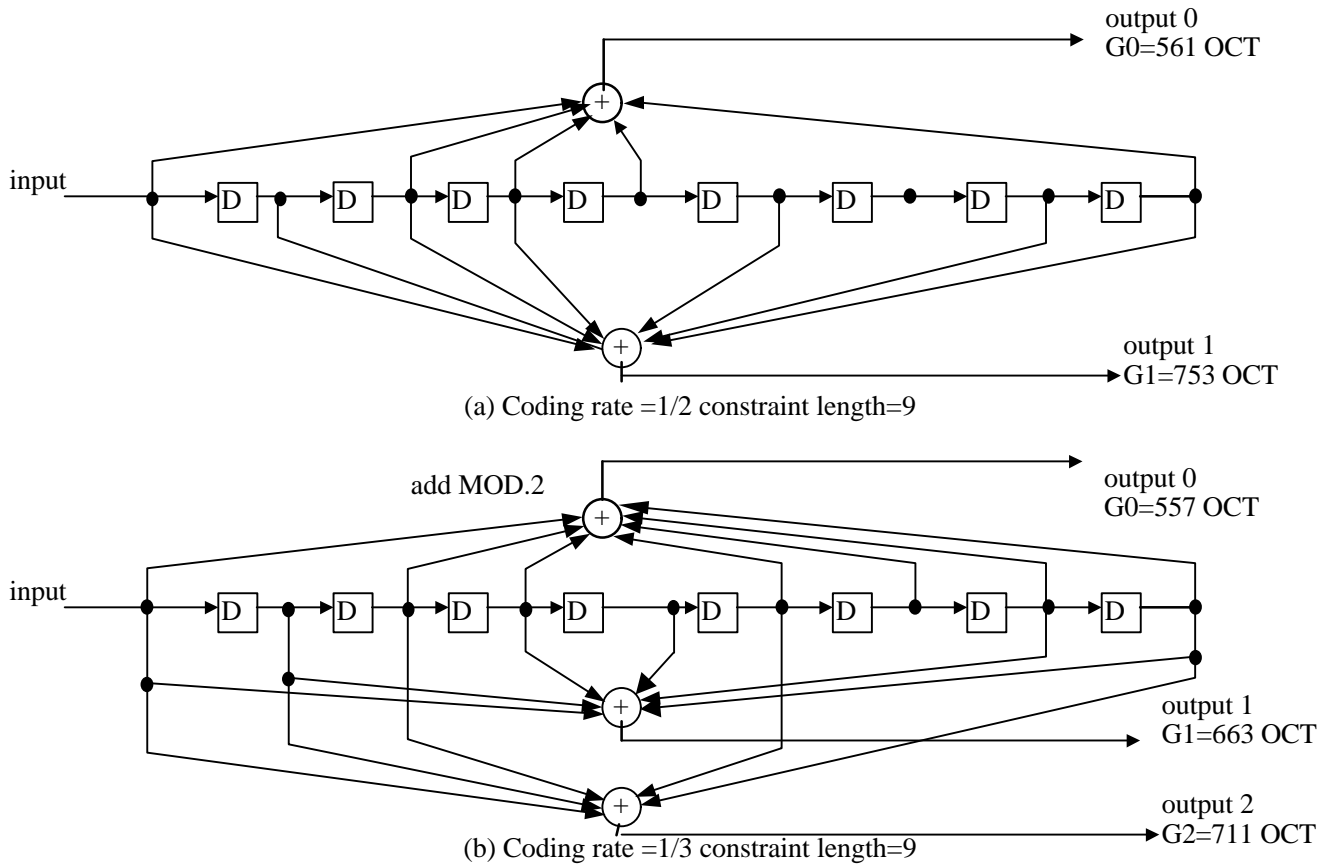

Fig. 6-2 Convolutional Coder

6.2.3.2 Turbo coding

6.2.3.2.1 Turbo coder

For data services requiring quality of service between 10^{-3} and 10^{-6} BER inclusive, parallel concatenated convolutional code (PCCC) with 8-state constituent encoders is used.

The transfer function of the 8-state constituent code for PCCC is

$$G(D) = \left[1, \frac{n(D)}{d(D)} \right]$$

where,

$$d(D) = 1 + D^2 + D^3$$

$$n(D) = 1 + D + D^3$$

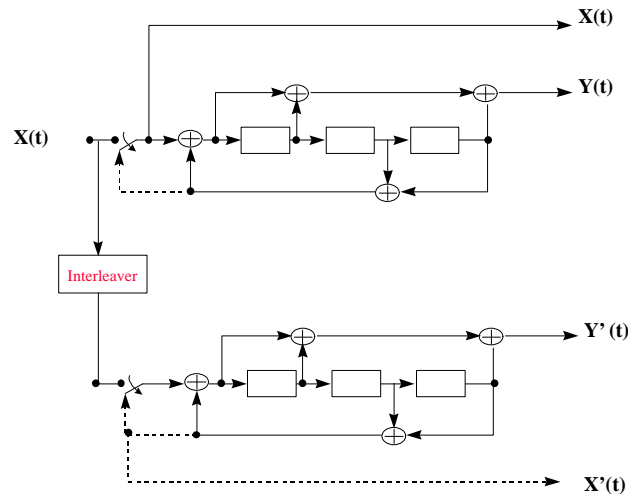

Figure 6-3. Structure of the 8 state PCCC encoder (dotted lines effective for trellis termination only)

The initial value of the shift registers of the PCCC encoder shall be all zeros.

The output of the PCCC encoder is punctured to produce coded bits corresponding to the desired code rate 1/3. For rate 1/3, none of the systematic or parity bits are punctured, and the output sequence is $X(0)$, $Y(0)$, $Y'(0)$, $X(1)$, $Y(1)$, $Y'(1)$, etc.

6.2.3.2.2 Trellis termination in turbo code

Trellis termination is performed by taking the tail bits from the shift register feedback after all information bits are encoded. Tail bits are added after the encoding of information bits.

The first three tail bits shall be used to terminate the first constituent encoder (upper switch of Figure 6-3 in lower position) while the second constituent encoder is disabled. The last three tail bits shall be used to terminate the second constituent encoder (lower switch of Figure 6-3 in lower position) while the first constituent encoder is disabled.

The transmitted bits for trellis termination shall then be

$$X(t) Y(t) X(t+1) Y(t+1) X(t+2) Y(t+2) X'(t) Y'(t) X'(t+1) Y'(t+1) X'(t+2) Y'(t+2).$$

6.2.3.2.3 Turbo code internal interleaver

Figure 6-5 depicts the overall 8 State PCCC Turbo coding scheme including Turbo code internal interleaver. The Turbo code internal interleaver consists of mother interleaver generation and pruning. For arbitrary given block length K , one mother interleaver is selected from the 134 mother interleavers set. The generation scheme of mother interleaver is described in section 6.2.2.3.1. After the mother interleaver generation, l -bits are pruned in order to adjust the mother interleaver to the block length K . The definition of l is shown in section 6.2.3.2.3.2..

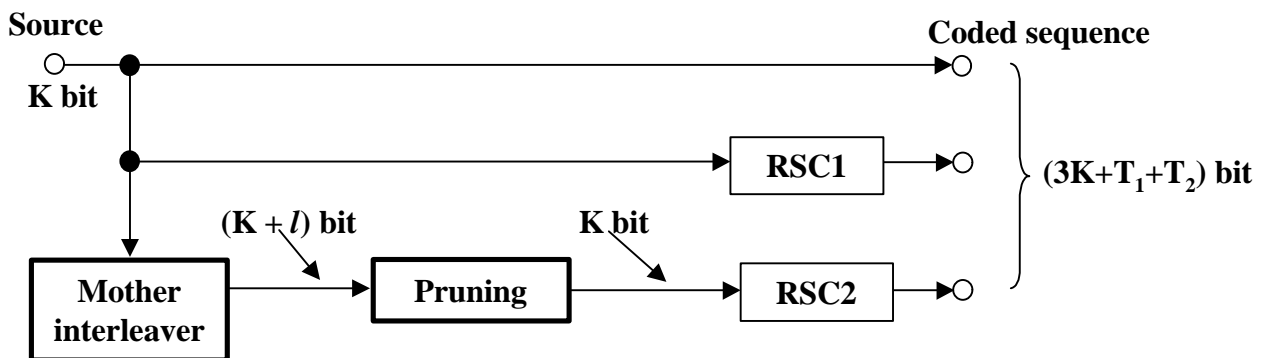

Figure 6-4. Overall 8 State PCCC Turbo Coding

6.2.3.2.3.1 Mother interleaver generation

The interleaving consists of three stages. In first stage, the input sequence is written into the rectangular matrix row by row. The second stage is intra-row permutation. The third stage is inter-row permutation. The three-stage permutations are described as follows, the input block length is assumed to be K (320 to 5114 bits).

First Stage:

- (1) Determine a row number R such that

$$R=10 \text{ (} K = 481 \text{ to } 530 \text{ bits; Case-1)}$$

$$R=20 \text{ (} K = \text{any other block length except } 481 \text{ to } 530 \text{ bits; Case-2)}$$

- (2) Determine a column number C such that

$$\text{Case-1; } C = p = 53$$

Case-2;

- (i) find minimum prime p such that,

$$0 \leq (p+1) - K/R$$

- (ii) if $(0 \leq p - K/R)$ then go to (iii)

$$\text{else } C = p+1.$$

- (iii) if $(0 \leq p-1 - K/R)$ then $C=p-1$.

$$\text{Else } C = p.$$

- (3) The input sequence of the interleaver is written into the $R \times C$ rectangular matrix row by row.

Second Stage:

A. If $C = p$

- (A-1) Select a primitive root g_0 from Table 6.2.2-2.

- (A-2) Construct the base sequence $c(i)$ for intra-row permutation as:

$$c(i) = [g_0 \times c(i-1)] \bmod p, \quad i = 1, 2, \dots, (p-2), \quad c(0) = 1.$$

- (A-3) Select the minimum prime integer set $\{q_j\}$ ($j=1, 2, \dots, R-1$) such that

$$\text{g.c.d}\{q_j, p-1\} = 1$$

$$q_j > 6$$

$$q_j > q_{(j-1)}$$

where g.c.d. is greatest common divider. And $q_0 = 1$.

- (A-4) The set $\{q_j\}$ is permuted to make a new set $\{p_j\}$ such that

$$p_{P(j)} = q_j, \quad j = 0, 1, \dots, R-1,$$

where $P(j)$ is the inter-row permutation pattern defined in the third stage.

- (A-5) Perform the j -th ($j = 0, 1, 2, \dots, C-1$) intra-row permutation as:

$$c_j(i) = c([i \times p_j] \bmod (p-1)), \quad i = 0, 1, 2, \dots, (p-2), \quad \text{and } c_j(p-1) = 0,$$

where $c_j(i)$ is the input bit position of i -th output after the permutation of j -th row.

If $C = p+1$

(B-1) Same as case A-1.

(B-2) Same as case A-2.

(B-3) Same as case A-3.

(B-4) Same as case A-4.

(B-5) Perform the j -th ($j = 0, 1, 2, \dots, R-1$) intra-row permutation as:

$$c_j(i) = c([i \times p_j] \bmod (p-1)), \quad i = 0, 1, 2, \dots, (p-2), \quad c_j(p-1) = 0, \text{ and } c_j(p) = p,$$

where $c_j(i)$ is the input bit position of i -th output after the permutation of j -th row.

(B-6) If $(K = C \times R)$ then exchange $c_{R-1}(p)$ with $c_{R-1}(0)$.

If $C = p-1$

(C-1) Same as case A-1.

(C-2) Same as case A-2.

(C-3) Same as case A-3.

(C-4) Same as case A-4.

(C-5) Perform the j -th ($j = 0, 1, 2, \dots, R-1$) intra-row permutation as:

$$c_j(i) = c([i \times p_j] \bmod (p-1)) - 1, \quad i = 0, 1, 2, \dots, (p-2),$$

where $c_j(i)$ is the input bit position of i -th output after the permutation of j -th row.

Third Stage:

Perform the inter-row permutation based on the following $P(j)$ ($j=0, 1, \dots, R-1$) patterns, where $P(j)$ is the original row position of the j -th permuted row.

P_A : {19, 9, 14, 4, 0, 2, 5, 7, 12, 18, 10, 8, 13, 17, 3, 1, 16, 6, 15, 11} for $R=20$

P_B : {19, 9, 14, 4, 0, 2, 5, 7, 12, 18, 16, 13, 17, 15, 3, 1, 6, 11, 8, 10} for $R=20$

P_C : {9, 8, 7, 6, 5, 4, 3, 2, 1, 0} for $R=10$

The usage of these patterns is as follows:

Block length K : $P(j)$

320 to 480-bit: P_A

481 to 530-bit: P_C

531 to 2280-bit: P_A

2281 to 2480-bit: P_B

2481 to 3160-bit: P_A

3161 to 3210-bit: P_B

3211 to 5114-bit: P_A

- (2) The output of the mother interleaver is the sequence read out column by column from the permuted $R \times C$ matrix.

Table 6.2.3-2. Table of prime p and associated primitive root

p	g_o	P	g_o	p	g_o	P	g_o	p	g_o
17	3	59	2	103	5	157	5	211	2
19	2	61	2	107	2	163	2	223	3
23	5	67	2	109	6	167	5	227	2
29	2	71	7	113	3	173	2	229	6
31	3	73	5	127	3	179	2	233	3
37	2	79	3	131	2	181	2	239	7
41	6	83	2	137	3	191	19	241	7
43	3	89	3	139	2	193	5	251	6
47	5	97	5	149	2	197	2	257	3
53	2	101	2	151	6	199	3		

6.2.3.2.3.2 Definition of the number of pruning bits

The output of the mother interleaver is pruned by deleting the l -bits in order to adjust the mother interleaver to the block length K , where the deleted bits are non-existent bits in the input sequence. The pruning bits number l is defined as:

$$l = R \times C - K,$$

where R is the row number and C is the column number defined in section 6.2.3.2.3.1.

6.2.4 Radio frame size equalisation

Radio frame size equalisation is padding the input bit sequence in order to ensure that the output can be segmented in F_i data segments of same size as described in the section 6.2.6.

The input bit sequence to the radio frame size equalisation is denoted by $c_{i1}, c_{i2}, c_{i3}, \dots, c_{iE_i}$, where i is TrCH number and E_i the number of bits. The output bit sequence is denoted by $t_{i1}, t_{i2}, t_{i3}, \dots, t_{iT_i}$, where T_i is the number of bits. The output bit sequence is derived as follows:

$$t_{ik} = c_{ik}, \text{ for } k = 1 \dots E_i \text{ and}$$

$$t_{ik} = \{0 \mid 1\} \text{ for } k = E_i + 1 \dots T_i, \text{ if } E_i < T_i$$

where

$$T_i = F_i * N_i \text{ and}$$

$$N_i = \lfloor (E_i - 1) / F_i \rfloor + 1 \text{ is the number of bits per segment after size equalisation.}$$

6.2.5 1st interleaving

The 1st interleaving is a block interleaver with inter-column permutations. The input bit sequence to the 1st interleaver is denoted by $x_{i1}, x_{i2}, x_{i3}, \dots, x_{iX_i}$, where i is TrCH number and X_i the number of bits (at this stage X_i is assumed and guaranteed to be an integer multiple of TTI). The output bit sequence is derived as follows:

- 1) Select the number of columns C_l from Table 6.2.5-1.
- 2) Determine the number of rows R_l defined as $R_l = X_i / C_l$

- 3) Write the input bit sequence into the $R_I \times C_I$ rectangular matrix row by row starting with bit $x_{i,1}$ in the first column of the first row and ending with bit $x_{i,(R_I C_I)}$ in column C_I of row R_I :

$$\begin{bmatrix} x_{i1} & x_{i2} & x_{i3} & \dots & x_{iC_I} \\ x_{i,(C_I+1)} & x_{i,(C_I+2)} & x_{i,(C_I+3)} & \dots & x_{i,(2C_I)} \\ \vdots & \vdots & \vdots & \dots & \vdots \\ x_{i,((R_I-1)C_I+1)} & x_{i,((R_I-1)C_I+2)} & x_{i,((R_I-1)C_I+3)} & \dots & x_{i,(R_I C_I)} \end{bmatrix}$$

- 4) Perform the inter-column permutation based on the pattern $\{P_1(j)\}$ ($j=0,1, \dots, C-1$) shown in Table 6.2.5-1, where $P_1(j)$ is the original column position of the j -th permuted column. After permutation of the columns, the bits are denoted by y_{ik} :

$$\begin{bmatrix} y_{i1} & y_{i,(R_I+1)} & y_{i,(2R_I+1)} & \dots & y_{i,((C_I-1)R_I+1)} \\ y_{i2} & y_{i,(R_I+2)} & y_{i,(2R_I+2)} & \dots & y_{i,((C_I-1)R_I+2)} \\ \vdots & \vdots & \vdots & \dots & \vdots \\ y_{iR_I} & y_{i,(2R_I)} & y_{i,(3R_I)} & \dots & y_{i,(C_I R_I)} \end{bmatrix}$$

- 5) Read the output bit sequence $y_{i1}, y_{i2}, y_{i3}, \dots, y_{i,(C_I R_I)}$ of the 1st interleaving column by column from the inter-column permuted $R_I \times C_I$ matrix. Bit $y_{i,1}$ corresponds to the first row of the first column and bit $y_{i,(R_I C_I)}$ corresponds to row R_I of column C_I .

The bits input to the 1st interleaving are denoted by $t_{i1}, t_{i2}, t_{i3}, \dots, t_{iT_i}$, where i is the TrCH number and E_i the number of bits. Hence, $x_{ik} = t_{ik}$ and $X_i = T_i$.

The bits output from the 1st interleaving are denoted by $d_{i1}, d_{i2}, d_{i3}, \dots, d_{iT_i}$, and $d_{ik} = y_{ik}$.

Table 6.2.5-1

TTI	Number of columns C_1	Inter-column permutation patterns
10 ms	1	{0}
20 ms	2	{0,1}
40 ms	4	{0,2,1,3}
80 ms	8	{0,4,2,6,1,5,3,7}

6.2.6 Radio frame segmentation

When the transmission time interval is longer than 10 ms, the input bit sequence is segmented and mapped onto consecutive radio frames. Following radio frame size equalisation the input bit sequence length is guaranteed to be an integer multiple of F_i .

The input bit sequence is denoted by $x_{i1}, x_{i2}, x_{i3}, \dots, x_{iX_i}$ where i is the TrCH number and X_i is the number bits. The F_i output bit sequences per TTI are denoted by $y_{i,n,1}, y_{i,n,2}, y_{i,n,3}, \dots, y_{i,n,Y_i}$ where n_i is the radio frame number in current TTI and Y_i is the number of bits per radio frame for TrCH i . The output sequences are defined as follows:

$$y_{i,n,k} = x_{i,((n_i-1)Y_i)+k}, n_i = 1 \dots F_i, j = 1 \dots Y_i$$

where

$$Y_i = (X_i / F_i) \text{ is the number of bits per segment,}$$

x_{ik} is the k^{th} bit of the input bit sequence and

$y_{i,n,k}$ is the k^{th} bit of the output bit sequence corresponding to the n^{th} radio frame

The n_i -th segment is mapped to the n_i -th radio frame of the transmission time interval.

The input bit sequence to the radio frame segmentation is denoted by $d_{i1}, d_{i2}, d_{i3}, \dots, d_{iT_i}$, where i is the TrCH number and T_i the number of bits. Hence, $x_{ik} = d_{ik}$ and $X_i = T_i$.

The output bit sequence corresponding radio frame n_i is denoted by $e_{i1}, e_{i2}, e_{i3}, \dots, e_{iN_i}$, where i is the TrCH number and N_i is the number of bits. Hence, $e_{i,k} = y_{i,n_i,k}$ and $N_i = Y_i$.

6.2.7 Rate matching

<Note: Rate matching scheme for Turbo codes is a working assumption of WGI.>

Rate matching means that bits on a TrCH are repeated or punctured. Higher layers assign a rate-matching attribute for each TrCH. This attribute is semi-static and can only be changed through higher layer signalling. The rate-matching attribute is used when the number of bits to be repeated or punctured is calculated.

The number of bits on a TrCH can vary between different transmission time intervals. When the number of bits between different transmission time intervals is changed, bits are repeated to ensure that the total bit rate after second multiplexing is identical to the total channel bit rate of the allocated dedicated physical channels.

Notation used in Section 6.2.7 and subsections:

N_{ij} : Number of bits in a radio frame before rate matching on TrCH i with transport format combination j .

ΔN_{ij} : If positive – number of bits to be repeated in each radio frame on TrCH i with transport format combination j .
If negative – number of bits to be punctured in each radio frame on TrCH i with transport format combination j .

RM_i : Semi-static rate matching attribute for TrCH i . Signalled from higher layers.

PL : Puncturing limit for uplink. This value limits the amount of puncturing that can be applied in order to minimise the number of dedicated physical channels. Signalled from higher layers.

$N_{data,j}$: Total number of bits that are available for a CCTrCH in a radio frame with transport format combination j .

I : Number of TrCHs in a CCTrCH.

Z_{mj} : Intermediate calculation variable.

F_i : Number of radio frames in the transmission time interval of TrCH i .

n_i : Radio frame number in the transmission time interval of TrCH i ($0 \leq n_i < F_i$).

Q : Average puncturing distance.

$I_F(n_i)$: The inverse interleaving function of the 1st interleaver (note that the inverse interleaving function is identical to the interleaving function itself for the 1st interleaver).

$S(n_i)$: The shift of the puncturing pattern for radio frame n_i .

$TF_i(j)$: Transport format of TrCH i for the transport format combination j .

$TFS(i)$:—The set of transport format indexes l for TrCH i .

e_{ini} : Initial value of variable e in the rate matching pattern determination algorithm of section 6.2.7.3.

e_{plus} : Increment of variable e in the rate matching pattern determination algorithm of section 6.2.7.3

e_{minus} : Decrement of variable e in the rate matching pattern determination algorithm of section 6.2.7.3

X: Systematic bit in 6.2.3.2.1.

Y: 1st parity bit (from the upper Turbo constituent encoder) in section 6.2.3.2.1.

Y': 2nd parity bit (from the lower Turbo constituent encoder) in section 6.2.3.2.1.

Note: Time index t in 6.2.3.2.1 is omitted for simplify the rate matching description

6.2.7.1 Determination of rate matching parameters

The following relations are used when calculating the rate matching pattern:

$$Z_{0,j} = 0$$

$$Z_{ij} = \left[\frac{\sum_{m=1}^i RM_m \cdot N_{mj}}{\sum_{m=1}^I RM_m \cdot N_{mj}} \cdot N_{data,j} \right] \quad \text{for all } i = 1 \dots I$$

$$\Delta N_{ij} = Z_{ij} - Z_{i-1,j} - N_{ij} \quad \text{for all } i = 1 \dots I$$

Puncturing can be used to minimise the number of required transmission capacity. The maximum amount of puncturing that can be applied is signalled from higher layers and denoted by PL . The possible values for N_{data} in uplink and downlink depend on the number of dedicated physical channels and on their characteristics (spreading factor, length of midamble and TFCL, usage of TPC and multiframe structure) which are assigned to the link, respectively. The supported set of N_{data} , denoted SET0, depends on the UE capabilities.

$N_{data,j}$ for the transport format combination j is determined by executing the following algorithm:

$$SET1 = \{ N_{data} \text{ in SET0 such that } \underbrace{N_{data} - PL \cdot \sum_{i=1}^I \frac{RM_i}{\min\{RM_l\}} \cdot N_{ij}}_{\text{non negative}} - \underbrace{PL \cdot \sum_{x=1}^I \frac{RM_x}{\min\{RM_y\}} \cdot N_{x,j}}_{\text{is}} \}$$

non negative }

$$N_{data,j} = \min SET1$$

The number of bits to be repeated or punctured, ΔN_{ij} , within one radio frame for each TrCH i is calculated with the relations given at the beginning of this section for all possible transport format combinations j and selected every radio frame. For each radio frame, the rate matching pattern is calculated with the algorithm in Section 6.2.6.2, where $\Delta N = \Delta N_{ij}$ and $N = N_{ij}$.

If $\Delta N_{ij} = 0$ then the output data of the rate matching is the same as the input data and no rate matching needs to be executed. Additionally

Otherwise, the rate matching pattern is calculated with the algorithm described in section 6.2.7.3. For this algorithm the parameters e_{ini} , e_{plus} , e_{minus} , and N are needed, which are calculated according to the following equations the following parameters are needed:

For convolutional codes, $a=2$ for the rate matching algorithm in section 6.2.7.3.

$$a = 2$$

$$\Delta N = \Delta N_{i,j}$$

$$N = N_{i,j}$$

$$q = \tilde{e}N_{ij}/(\tilde{D}DN_{ij}\tilde{D})\hat{u}$$

If q is even

then $q' = q - \text{gcd}(q, F_i)/F_i$ -- where $\text{gcd}(q, F_i)$ means greatest common divisor of q and F_i

-- note that q' is not an integer, but a multiple of 1/8

else

$$q' = q$$

endif

for $\underline{x} = 0$ to F_i-1

$$S(I_F(\underline{x}*q'\hat{u} \bmod F_i)) = (\underline{x}*q'\hat{u} \bmod F_i)$$

End for

~~For each radio frame, the rate matching pattern is calculated with the algorithm in section 6.2.7.3, where:~~

$$\underline{DN} = \underline{DN}_{i,j}$$

$$N = N_{i,j} \text{ and}$$

$$e_{ini} = (a \times \mathcal{S}(n_i) \times \underline{DN} + N) \bmod a \times N, \text{ if } e_{ini} = 0 \text{ then } e_{ini} = a \times N.$$

$$e_{plus} = a \times N$$

$$e_{minus} = a \times \underline{DN}$$

puncturing for $\underline{DN} < 0$, repeating otherwise.

For turbo codes,

if repetition is to be performed, such as $\underline{DN}_{i,j} > 0$, parameters for turbo codes are the same as parameter for convolutional codes.

If puncturing is to be performed, parameters are as follows.

$A \underline{a} = 2$ for Y parity sequence, and

$a = 1$ for Y' parity sequence.

~~For each radio frame, the rate matching pattern is calculated with the algorithm in section 6.2.7.3, where:~~

$$\underline{DN} = \begin{cases} \lfloor \underline{DN}_{i,j} / 2 \rfloor & \text{for Y sequence} \\ \lfloor \underline{DN}_{i,j} / 2 \rfloor & \text{for Y' sequence} \end{cases}$$

$$N = \tilde{e}N_{ij}/3\hat{u},$$

$$q = \tilde{e}N/|\underline{DN}| \hat{u}$$

if($q \leq 2$)

for $x=0$ to F_i-1

if(Y sequence)

$$S[I_F[(3x+1) \bmod F_i]] = x \bmod 2;$$

if(Y' sequence)

$$S[I_F[(3x+2) \bmod F_i]] = x \bmod 2;$$

```

end for
else
  if  $q$  is even
    then  $q' = q - gcd(q, F_i) / F_i$  -- where  $gcd(q, F_i)$  means greatest common divisor of  $q$  and  $F_i$ 
      -- note that  $q'$  is not an integer, but a multiple of 1/8
    else  $q' = q$ 
    endif

    for  $x=0$  to  $F_i - 1$ 
       $r = \epsilon x * q' \cdot \dot{u} \bmod F_i$ ;
      if(Y sequence)
         $S[I_F[(3r+1) \bmod F_i]] = \epsilon x * q' \cdot \dot{u} \bmod F_i$ ;
      if(Y' sequence)
         $S[I_F[(3r+2) \bmod F_i]] = \epsilon x * q' \cdot \dot{u} \bmod F_i$ ;
      endif
    endfor
  endif

```

$e_{ini} = (a \cdot S(n_i) \cdot |\Delta N| + N) \bmod a \cdot N$, if $e_{ini} = 0$ then $e_{ini} = a \cdot N$.

$e_{plus} = a \cdot N$

$e_{minus} = a \cdot |DN|$

puncturing for $DN < 0$, repeating otherwise.

6.2.7.2 Bit separation for rate matching

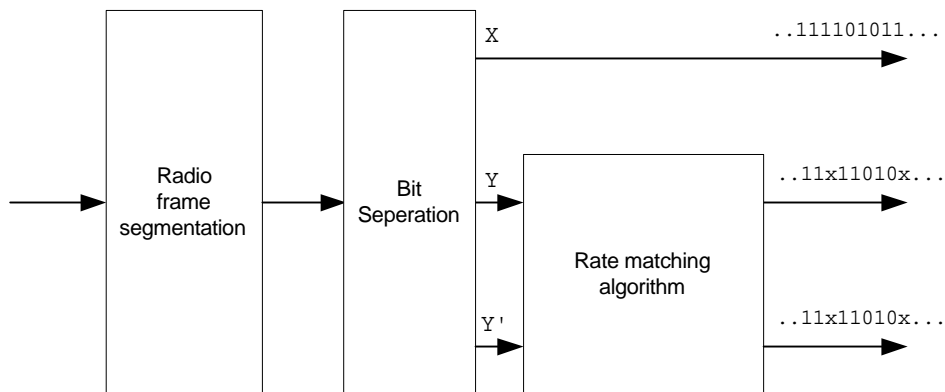

Figure 6-5. Overall rate matching block diagram after first interleaving where x denotes punctured bit.

Rate matching puncturing for Turbo codes is applied separately to Y and Y' sequences. No puncturing is applied to X sequence. Therefore, it is necessary to separate X , Y , and Y' sequences before rate matching is applied.

There are two different alternation patterns in bit stream from Radio frame segmentation according to the TTI of a TrCH as shown in Table 6.2.7-1.

Table 6.2.7-1 Alternation patterns of bits from radio frame segmentation

TTI (msec)	Alternation patterns
10, 40	... X,Y,Y',...
20, 80	... X,Y',Y,...

In addition, each radio frame of a TrCH starts with different initial parity type. Table 6.2.7-2 shows the initial parity type of each radio frame of a TrCH with TTI = {10, 20, 40, 80} msec.

Table 6.2.7-2 Initial parity type of radio frames of TrCH

TTI (msec)	Radio frame indexes (n_i)							
	0	1	2	3	4	5	6	7
10	X	NA	NA	NA	NA	NA	NA	NA
20	X	Y	NA	NA	NA	NA	NA	NA
40	X	Y'	Y	X	NA	NA	NA	NA
80	X	Y	Y'	X	Y	Y'	X	Y

Table 6.2.7-1 and 6.2.7-2 defines a complete output bit pattern from Radio frame segmentation.

Ex. 1. TTI = 40 msec, $n_i = 2$

Radio frame pattern: Y, Y', X, Y, Y', X, Y, Y', X, ...

Ex. 2 TTI = 40 msec, $n_i = 3$

Radio frame pattern: X, Y, Y', X, Y, Y', X, Y, Y', X, ...

Therefore, bit separation is achieved with the alternative selection of bits with the initial parity type and alternation pattern specified in Table 6.2.7-1 and 6.2.7-2 according to the TTI and n_i of a TrCH.

6.2.7.3 Rate matching pattern determination

The bits input to the rate matching are denoted by $e_{i1}, e_{i2}, e_{i3}, \dots, e_{iN_i}$, where i is the TrCH with $N = N_{ij} = N_i$. Here N is the parameter given in section 6.2.7.1. The bits output from the rate matching are denoted by $f_{i1}, f_{i2}, f_{i3}, \dots, f_{iV_i}$, where i is the TrCH number and $V_i = N + DN = N_i + DN_i$.

Note that the transport format combination number j for simplicity has been left out in the bit numbering.

The rate matching rule is as follows:

if puncturing is to be performed

$$y = \text{DN}$$

```

e = eini _____ -- initial error between current and desired puncturing ratio
m = 1 _____ -- index of current bit
do while m <= N
    e = e - eminusα*y -- update error
    if e <= 0 then _____ -- check if bit number m should be punctured
        puncture bit ei,m
        e = e + eplusα*N -- update error
    end if
    m = m + 1 _____ -- next bit
end do
else
y = DN
e = eini _____ -- initial error between current and desired puncturing ratio
m = 1 _____ -- index of current bit
do while m <= N
    e = e - eminusα*y -- update error
    do while e <= 0 _____ -- check if bit number m should be repeated
        repeat bit ei,m
        e = e + eplusα*N _____ -- update error
    enddo
    m = m + 1 _____ -- next bit
end do
end if

```

A repeated bit is placed directly after the original one.

6.2.8 TrCH multiplexing

Every 10 ms, one radio frame from each TrCH is delivered to the TrCH multiplexing. These radio frames are serially multiplexed into a coded composite transport channel (CCTrCH).

The bits input to the TrCH multiplexing are denoted by $f_{i1}, f_{i2}, f_{i3}, \dots, f_{iV_i}$, where i is the TrCH number and V_i is the number of bits in the radio frame of TrCH i . The number of TrCHs is denoted by I . The bits output from TrCH multiplexing are denoted by $s_1, s_2, s_3, \dots, s_S$, where S is the number of bits, i.e. $S = \sum_i V_i$. The TrCH multiplexing

is defined by the following relations:

$$\begin{aligned}
 s_k &= f_{1k} & k &= 1, 2, \dots, V_1 \\
 s_k &= f_{2,(k-V_1)} & k &= V_1+1, V_1+2, \dots, V_1+V_2 \\
 s_k &= f_{3,(k-(V_1+V_2))} & k &= (V_1+V_2)+1, (V_1+V_2)+2, \dots, (V_1+V_2)+V_3 \\
 \dots & & & \\
 s_k &= f_{I,(k-(V_1+V_2+\dots+V_{I-1}))} & k &= (V_1+V_2+\dots+V_{I-1})+1, (V_1+V_2+\dots+V_{I-1})+2, \dots, (V_1+V_2+\dots+V_{I-1})+V_I
 \end{aligned}$$

6.2.9 Physical channel segmentation

When more than one PhCH is used, physical channel segmentation divides the bits among the different PhCHs. The bits input to the physical channel segmentation are denoted by $s_1, s_2, s_3, \dots, s_S$, where S is the number of bits input to the physical channel segmentation block. The number of PhCHs is denoted by P .

The bits after physical channel segmentation are denoted $u_{p1}, u_{p2}, u_{p3}, \dots, u_{pU_p}$, where p is PhCH number and U_p is the in general variable number of bits in the respective radio frame for each PhCH. The relation between s_k and u_{pk} is given below.

Bits on first PhCH after physical channel segmentation:

$$u_{1k} = s_k \quad k = 1, 2, \dots, U_1$$

Bits on second PhCH after physical channel segmentation:

$$u_{2k} = s_{(k+U_1)} \quad k = 1, 2, \dots, U_2$$

...

Bits on the P^{th} PhCH after physical channel segmentation:

$$u_{Pk} = s_{(k+U_1+\dots+U_{P-1})} \quad k = 1, 2, \dots, U_P$$

6.2.10 2nd interleaving

The 2nd interleaving can be applied jointly to all data bits transmitted during one frame, or separately within each timeslot, on which the CCTrCH is mapped. The selection of the 2nd interleaving scheme is controlled by higher layer.

6.2.10.1 Frame related 2nd interleaving

In case of frame related interleaving, the bits input to the 2nd interleaver are denoted $x_1, x_2, x_3, \dots, x_U$, where U is the total number of bits after TrCH multiplexing transmitted during the respective radio frame.

The relation between x_k and the bits u_{pk} in the respective physical channels is given below:

$$x_k = u_{1k} \quad k = 1, 2, \dots, U_1$$

$$x_{(k+U_1)} = u_{2k} \quad k = 1, 2, \dots, U_2$$

...

$$x_{(k+U_1+\dots+U_{P-1})} = u_{Pk} \quad k = 1, 2, \dots, U_P$$

The following steps have to be performed once for each CCTrCH:

- (1) Set the number of columns $C_2 = 30$. The columns are numbered 0, 1, 2, ..., C_2-1 from left to right.
- (2) Determine the number of rows R_2 by finding minimum integer R_2 such that $U \leq R_2 C_2$.
- (3) The bits input to the 2nd interleaving are written into the $R_2 \times C_2$ rectangular matrix row by row.

$$\begin{bmatrix} x_1 & x_2 & x_3 & \dots & x_{30} \\ x_{31} & x_{32} & x_{33} & \dots & x_{60} \\ \vdots & \vdots & \vdots & \dots & \vdots \\ x_{(R_2-1)30+1} & x_{(R_2-1)30+2} & x_{(R_2-1)30+3} & \dots & x_{R_2 \cdot 30} \end{bmatrix}$$

- (4) Perform the inter-column permutation based on the pattern $\{P_2(j)\}$ ($j = 0, 1, \dots, C_2-1$) that is shown in Table 6.2.9-1, where $P_2(j)$ is the original column position of the j -th permuted column. After permutation of the columns, the bits are denoted by y_k .

$$\begin{bmatrix} y_1 & y_{R_2+1} & y_{2R_2+1} & \dots & y_{29R_2+1} \\ y_2 & y_{R_2+2} & y_{2R_2+2} & \dots & y_{29R_2+2} \\ \vdots & \vdots & \vdots & \dots & \vdots \\ y_{R_2} & y_{2R_2} & y_{3R_2} & \dots & y_{30R_2} \end{bmatrix}$$

- (5) The output of the 2nd interleaving is the bit sequence read out column by column from the inter-column permuted $R_2 \times C_2$ matrix. The output is pruned by deleting bits that were not present in the input bit sequence, i.e. bits y_k that corresponds to bits x_k with $k > U$ are removed from the output. The bits after 2nd interleaving are denoted by v_1, v_2, \dots, v_U , where v_1 corresponds to the bit y_k with smallest index k after pruning, v_2 to the bit y_k with second smallest index k after pruning, and so on.

6.2.10.2 Timeslot related 2nd interleaving

In case of timeslot related 2nd interleaving, the bits input to the 2nd interleaver are denoted $x_{t1}, x_{t2}, x_{t3}, \dots, x_{tU_t}$, where t refers to a certain timeslot, and U_t is the number of bits transmitted in this timeslot during the respective radio frame.

In each timeslot t the relation between x_{tk} and u_{pk} is given below with P_t referring to the number of physical channels within the respective timeslot:

$$x_{tk} = u_{1k} \quad k = 1, 2, \dots, U_1$$

$$x_{t(k+U_1)} = u_{2k} \quad k = 1, 2, \dots, U_2$$

...

$$x_{t(k+U_1+\dots+U_{P_t-1})} = u_{P_t k} \quad k = 1, 2, \dots, U_{P_t}$$

The following steps have to be performed for each timeslot t , on which the respective CCTrCH is mapped:

- (1) Set the number of columns $C_2 = 30$. The columns are numbered 0, 1, 2, ..., C_2-1 from left to right.
- (2) Determine the number of rows R_2 by finding minimum integer R_2 such that $U_t \leq R_2 C_2$.
- (3) The bits input to the 2nd interleaving are written into the $R_2 \times C_2$ rectangular matrix row by row.

$$\begin{bmatrix} x_{t1} & x_{t2} & x_{t3} & \dots & x_{t30} \\ x_{t31} & x_{t32} & x_{t33} & \dots & x_{t60} \\ \vdots & \vdots & \vdots & \dots & \vdots \\ x_{t,((R_2-1)30+1)} & x_{t,((R_2-1)30+2)} & x_{t,((R_2-1)30+3)} & \dots & x_{t,(R_2 30)} \end{bmatrix}$$

- (4) Perform the inter-column permutation based on the pattern $\{P_2(j)\}$ ($j = 0, 1, \dots, C_2-1$) that is shown in Table 6.2.9-1, where $P_2(j)$ is the original column position of the j -th permuted column. After permutation of the columns, the bits are denoted by y_{tk} .

$$\begin{bmatrix} y_{t1} & y_{t,(R_2+1)} & y_{t,(2R_2+1)} & \dots & y_{t,(29R_2+1)} \\ y_{t2} & y_{t,(R_2+2)} & y_{t,(2R_2+2)} & \dots & y_{t,(29R_2+2)} \\ \vdots & \vdots & \vdots & \dots & \vdots \\ y_{tR_2} & y_{t,(2R_2)} & y_{t,(3R_2)} & \dots & y_{t,(30R_2)} \end{bmatrix}$$

- (5) The output of the 2nd interleaving is the bit sequence read out column by column from the inter-column permuted $R_2 \times C_2$ matrix. The output is pruned by deleting bits that were not present in the input bit sequence, i.e. bits y_{tk} that corresponds to bits x_{tk} with $k > U_t$ are removed from the output. The bits after 2nd interleaving are denoted by $v_{i1}, v_{i2}, \dots, v_{iU_t}$, where v_{i1} corresponds to the bit y_{tk} with smallest index k after pruning, v_{i2} to the bit y_{tk} with second smallest index k after pruning, and so on.

Table 6.2.10-1

Column number C_2	Inter-column permutation pattern
30	{0, 20, 10, 5, 15, 25, 3, 13, 23, 8, 18, 28, 1, 11, 21, 6, 16, 26, 4, 14, 24, 19, 9, 29, 12, 2, 7, 22, 27, 17}

6.2.11 Physical channel mapping

The PhCH for both uplink and downlink is defined in [6]. The bits after physical channel mapping are denoted by $w_{p1}, w_{p2}, \dots, w_{pU_p}$, where p is the PhCH number and U_p is the number of bits in one radio frame for the respective PhCH. The bits w_{pk} are mapped to the PhCHs so that the bits for each PhCH are transmitted over the air in ascending order with respect to k . The mapping scheme depends on the applied 2^{nd} interleaving scheme.

6.2.11.1 Mapping scheme after frame related 2^{nd} interleaving

The following mapping rule is applied:

Bits on first PhCH after physical channel mapping:

$$w_{1k} = v_k \quad k = 1, 2, \dots, U_1$$

Bits on second PhCH after physical channel mapping:

$$w_{2k} = v_{(k+U_1)} \quad k = 1, 2, \dots, U_2$$

...

Bits on the P^{th} PhCH after physical channel mapping:

$$w_{Pk} = v_{(k+U_1+\dots+U_{P-1})} \quad k = 1, 2, \dots, U_P$$

6.2.11.2 Mapping scheme after timeslot related 2^{nd} interleaving

For each timeslot only those physical channels with $p = 1, 2, \dots, P_t$ are considered respectively, which are transmitted in that timeslot, and the following mapping scheme is applied:

Bits on first PhCH in timeslot t after physical channel mapping:

$$w_{1k} = v_{tk} \quad k = 1, 2, \dots, U_1$$

Bits on second PhCH in timeslot t after physical channel mapping:

$$w_{2k} = v_{t(k+U_1)} \quad k = 1, 2, \dots, U_2$$

...

Bits on the PhCH P_t in timeslot t after physical channel mapping:

$$w_{P_t k} = v_{(k+U_1+\dots+U_{P_t-1})} \quad k = 1, 2, \dots, U_{P_t}$$

6.2.12 Multiplexing of different transport channels onto one CCTrCH, and mapping of one CCTrCH onto physical channels

Different transport channels can be encoded and multiplexed together into one Coded Composite Transport Channel (CCTrCH). The following rules shall apply to the different transport channels which are part of the same CCTrCH:

- 1) Transport channels multiplexed into one CCTrCH should have co-ordinated timings in the sense that transport blocks arriving from higher layers on different transport channels of potentially different transmission time intervals shall have aligned transmission time instants as shown in figure 6-6.
- 2) Different CCTrCHs cannot be mapped onto the same physical channel.
- 3) One CCTrCH shall be mapped onto one or several physical channels.

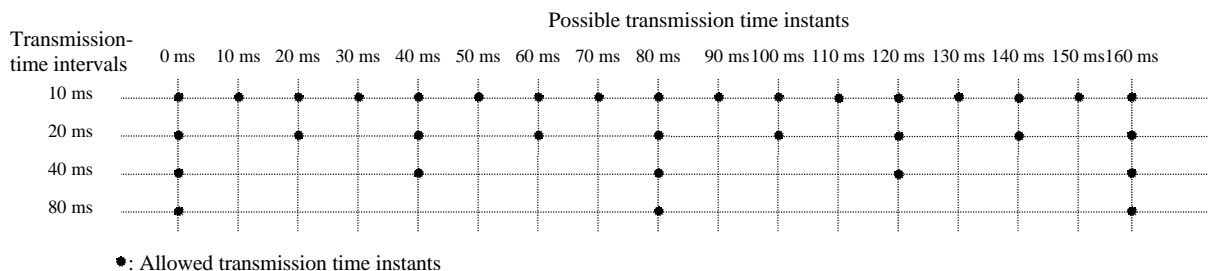

Figure 6-6: Possible transmission time instants regarding CCTrCH

- 4) Dedicated Transport channels and common transport channels cannot be multiplexed into the same CCTrCH.
 - 5) For the common transport channels, only the FACH and PCH may belong to the same CCTrCH.
 - 6) Each CCTrCH carrying a BCH shall carry only one BCH and shall not carry any other Transport Channel.
 - 7) Each CCTrCH carrying a RACH shall carry only one RACH and shall not carry any other Transport Channel.
- Hence, there are two types of CCTrCH

CCTrCH of dedicated type, corresponding to the result of coding and multiplexing of one or several DCH.

CCTrCH of common type, corresponding to the result of the coding and multiplexing of a common channel, i.e. RACH and USCH in the uplink and DSCH, BCH, FACH or PCH in the downlink, respectively.
There may be one TFCI for each CCTrCH of dedicated type as well as for USCH- and DSCH-CCTrCHs.

6.2.12.1 Allowed CCTrCH combinations for one UE

6.2.12.1.1 Allowed CCTrCH combinations on the uplink

The following CCTrCH combinations for one UE are allowed, also simultaneously:

- 1) several CCTrCH of dedicated type
- 2) several CCTrCH of common type

6.2.12.1.2 Allowed CCTrCH combinations on the downlink

The following CCTrCH combinations for one UE are allowed, also simultaneously:

- 3) several CCTrCH of dedicated type
- 4) several CCTrCH of common type

6.2.13 Transport format detection

Transport format detection can be performed both with and without Transport Format Combination Indicator (TFCI). If a TFCI is transmitted, the receiver detects the transport format combination from the TFCI. When no TFCI is transmitted, so called blind transport format detection is used, i.e. the receiver side uses the possible transport format combinations as a priori information.

6.2.13.1 Blind transport format detection

Blind transport format detection may be performed in the receiver by trying all possible combinations of the transport format.

6.2.13.2 Explicit transport format detection based on TFCI

6.2.13.2.1 Transport Format Combination Indicator (TFCI)

The Transport Format Combination Indicator (TFCI) informs the receiver of the transport format combination of the CCTrCHs. As soon as the TFCI is detected, the transport format combination, and hence the individual transport channels' transport formats are known, and decoding of the transport channels can be performed.

6.3 Coding for layer 1 control

6.3.1 Coding of transport format combination indicator (TFCI)

The number of TFCI bits is variable and is set at the beginning of the call via higher layer signalling. Encoding of the TFCI bits depends on the number of them. If there are 6-10 bits of TFCI the channel encoding is done as described in

section 6.3.1.1. Also specific coding of less than 6 bits is possible as explained in 6.3.1.3. For improved TFCI detection reliability repetition is used to increase the number of TFCI bits. Additionally, with any TFCI coding scheme it is assumed that in the receiver combining of two successive TFCI words will be performed if the shortest transmission time interval of any TrCH is at least 20 ms.

6.3.1.1 Default TFCI word

TFCI is encoded by the (32,10) sub-code of second order Reed-Muller code. The code words of the (32,10) sub-code of second order Reed-Muller code are linear combination of some among 10 basis sequences: all 1's, 5 OVSF codes ($C_5(1)$, $C_5(2)$, $C_5(4)$, $C_5(8)$, $C_5(16)$), and 4 masks (Mask1, Mask2, Mask3, Mask4). The 4 mask sequences are as follows in Table 6.3.1-1.

Table 6.3.1-1. Mask sequences

Mask 1	00101000011000111111000001110111
Mask 2	00000001110011010110110111000111
Mask 3	00001010111110010001101100101011
Mask 4	00011100001101110010111101010001

For information bits $a_0, a_1, a_2, a_3, a_4, a_5, a_6, a_7, a_8, a_9$ (a_0 is LSB and a_9 is MSB), the encoder structure is as follows in Figure 6-7.

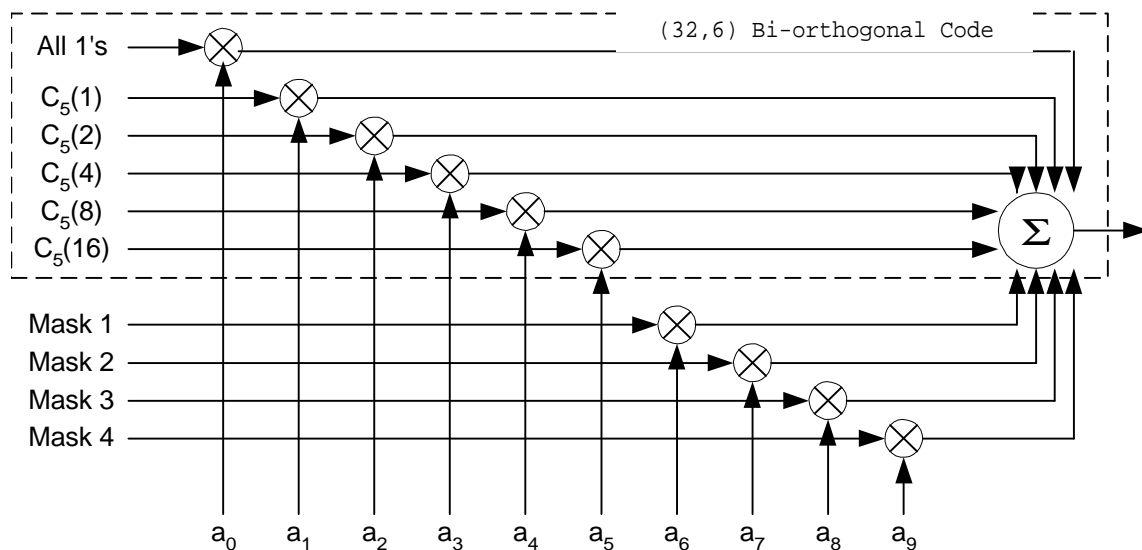

Figure 6-7. Encoder structure for (32,10) sub-code of second order Reed-Muller code

6.3.1.2 Coding of short TFCI lengths

If the number of TFCI bits is 1 or 2, then repetition will be used for coding. In this case each bit is repeated 3 times giving 4-bit transmission for a single TFCI bit and 8-bit transmission for 2 TFCI bits.

If the number of TFCI bits is in the range of 3 to 5, then one word of the biorthogonal (16,5) block code will be used.

The code words of the biorthogonal (16, 5) code are from two mutually biorthogonal sets,

$S_{C_4} = \{C_4(0), C_4(1), \dots, C_4(15)\}$ and its binary complement, $\bar{S}_{C_4} = \{\bar{C}_4(0), \bar{C}_4(1), \dots, \bar{C}_4(15)\}$. Words of set

S_{C_4} are from the level 4 of the code three, which is generated, using the short code generation method defined in TS 25.223. The mapping of information bits to code words is shown in the Table 6.3.1-2.

Table 6.3.1- 2 Mapping of information bits to code words for biorthogonal (16, 5) code.

Information bits	Code word
00000	$C_4(0)$
00001	$\overline{C_4(0)}$
00010	$C_4(1)$
...	...
11101	$\overline{C_4(14)}$
11110	$C_4(15)$
11111	$\overline{C_4(15)}$

6.3.2 Operation of Transport-format-combination indicator (TFCI) in Split Mode

In the case of DCH in Split Mode, the UTRAN shall operate with as follows:

- If one of the links is associated with a DSCH, the TFCI code word may be split into two code words of length 16. The use of such a functionality shall be indicated by higher layer signalling.

TFCI information is encoded by biorthogonal (16, 5) block code. The code words of the biorthogonal (16, 5) code are from two mutually biorthogonal sets, $S_{C_4} = \{C_4(0), C_4(1), \dots, C_4(15)\}$ and its binary complement, $\overline{S}_{C_4} = \{\overline{C_4(0)}, \overline{C_4(1)}, \dots, \overline{C_4(15)}\}$. Code words of set S_{C_4} are from the level 16 of the code three of OVSF codes defined in document TS 25.213. The mapping of information bits to code words is shown in the Table 2.

Table 6.3.2-1: Mapping of information bits to code words for biorthogonal (16, 5) code

Information bits	Code word
00000	$C_4(0)$
00001	$\overline{C_4(0)}$
00010	$C_4(1)$
...	...
11101	$\overline{C_4(14)}$
11110	$C_4(15)$
11111	$\overline{C_4(15)}$

6.3.3.2 Coding of Paging Indicator (PI)

The PI is an identifier to instruct the UE whether there is a paging message for the groups of mobiles that are associated to the PI. The length L_{PI} of the PI is $L_{PI}=2$, $L_{PI}=4$ or $L_{PI}=8$ symbols. The coding of the PI is shown in table 6.3.3-1.

Table 6.3.3-1 Coding of the PI

Bits	PI	Content
All '0'	Not set	There is no necessity to receive PCH
All '1'	Set	There is necessity to receive PCH-

6.3.46.3.3 Coding of Transmit Power Control (TPC)

The TPC command is an identifier sent in uplink transmission only, to instruct the NodeB whether Tx power has to be increased or decreased. The length of the TPC command is one symbol. The coding of the TPC command is shown in table 6.3.3-1.

Table 6.3.4-1 Coding of the TPC

TPC	TPC Bits	Meaning
'Down'	00	Decrease Tx Power
'Up'	11	Increase Tx Power

7 History

Document history		
v0.0.1	1999-02-12	Document created based on the documents Tdoc UMTS (xx.10) V0.5.0 and ARIB Volume 3 Version 1.0-1.0.
V0.0.2	1999-02-18	Document updated based on comments in the TSG-RAN WG1 e-mail reflector.
V0.1.0	1999-02-26	This version was approved at WG1#2 as the initial merge of ARIB and ETSI documents.
V0.1.1	1999-03-03	Document updated based on Adhoc decisions and technical comments made at WG1#2.
V1.0.1	1999-03-23	Document updated based on AdHoc decisions made at WG1#3.
V1.0.2	1999-03-24	Corrections made based on feedback in WG1#3 meeting.
V1.1.0	1999-03-26	This version was approved at WG1#3 meeting.
V1.1.1	1999-04-19	Document updated based on AdHoc decisions at WG1#4.
V1.1.2	1999-04-20	Document updated based on additional text proposals at WG1#4.
V2.0.0	1999-04-20	This version was approved at WG1#4 as an input to TSG RAN meeting.
TS 25.222 V1.0.0	1999-04-22	Noted by TSG-RAN as TS 25.222 V1.0.0
TS 25.222 V1.0.1	1999-06-04	Updated based on AdHoc decisions at WG1#5
TS 25.222 V1.1.0	1999-06-04	This version was approved at WG1#5 meeting.
TS 25.222 V2.0.0	1999-06-22	Endorsed by TSG-RAN as V2.0.0
TS 25.222 V2.0.1	1999-08-03	Updated based on harmonization decisions and Ad Hoc decisions at WG1#6
TS 25.222 V2.0.2	1999-08-23	Editorial corrections based on feedback on WG1 reflector.
TS 25.222 V2.1.0	1999-08-30	Accepted as an output of WG1#6 meeting at WG1#7

TS 25.222 V2.1.1	1999-09-02	Document updated based on text proposals at WG1#7
TS 25.222 V2.1.2	1999-09-03	Tdoc 99d84 added.
TS 25.222 V2.2.0	1999-09-03	Approved at WG1#7 for RAN submission
<p>The editor for TS 25.222 Multiplexing and channel coding (TDD), is:</p> <p>Jussi Kahtava Nokia-Japan Email: jussi.kahtava@nokia.com</p> <p>This document is written in Microsoft Word 97.</p>		