

TS S1.11 V1.1.1 (1999-04)

Technical Specification

**3rd Generation Partnership Project (3GPP);
Technical Specification Group (TSG)
Radio Access Network (RAN);
Working Group 1 (WG1);
Physical channels and mapping of transport channels onto
physical channels (FDD)**

3GPP

Reference

<Workitem>
(<Shortfilename>.PDF)

Keywords

<keyword[, keyword]>

3GPP

Postal address

Office address

Internet

secretariat@3gpp.org
Individual copies of this deliverable
can be downloaded from
<http://www.3gpp.org>

3GPP

Copyright Notification

No part may be reproduced except as authorized by written permission.
The copyright and the foregoing restriction extend to reproduction in all media.

Contents

Contents	33
Intellectual Property Rights	64
Foreword.....	64
1 Scope	74
2 References	74
3 Definitions, symbols and abbreviations	85
3.1 Definitions	85
3.2 Symbols	95
3.3 Abbreviations.....	95
4 Transport channels	116
4.1 Dedicated transport channels	116

3GPP

4.1.2	[FAUSCH – Fast Uplink Signalling Channel]	126
4.2	Common transport channels.....	126
4.2.1	BCH – Broadcast Channel	136
4.2.2	FACH – Forward Access Channel	136
4.2.3	PCH – Paging Channel.....	137
4.2.4	RACH – Random Access Channel	137
4.2.5	DSCH – Downlink Shared Channel	147
4.2.6	DSCH Control Channel.....	147
5	Physical channels.....	157
5.1	The physical resource	167
5.2	Uplink physical channels	168
5.2.1	Dedicated uplink physical channels	168
5.2.2	Common uplink physical channels.....	2410
5.2.2.1	Physical Random Access Channel.....	2410
5.2.2.1.1	RACH transmission	2411
5.2.2.1.2	RACH preamble part	2611
5.2.2.1.3	RACH message part.....	2611
5.2.2.1.4	[FAUSCH transmission]	2913

3GPP

5.2.2.1.5	[Sharing of PRACH by RACH and FAUSCH].....	3143
-----------	--	------

5.3	Downlink physical channels.....	3243
5.3.1	Downlink Transmit Diversity	3243
5.3.1.1	Open loop transmit diversity.....	3414
5.3.1.1.1	Space time block coding based transmit antenna diversity (STTD).....	3414
5.3.2	Dedicated downlink physical channels.....	3715
5.3.2.1	STTD for DPCH.....	4619
5.3.2.2	Dedicated channel pilots with feedback mode transmit diversity	4920
5.3.3	Common downlink physical channels	5124
5.3.3.1	Primary Common Control Physical Channel (CCPCH)	5124
5.3.3.1.1	Primary CCPCH structure with STTD encoding	5422
5.3.3.1.2	Primary CCPCH structure with FB mode transmit diversity.....	5723
5.3.3.2	Secondary Common Control Physical Channel	5823
5.3.3.2.1	Primary CCPCH structure with STTD encoding	6325
5.3.3.3	Synchronisation Channel	6625
5.3.3.4	Physical Shared Channel Control Channel (PSCCCH)	6826
5.3.3.5	Physical Downlink Shared Channel.....	7026
5.3.3.5.1	DSCH associated with a DCH	7126
5.3.3.5.2	DSCH associated with a DSCH control channel.....	7227
5.3.3.6	Acquisition Indication Channel (AICH).....	7227

3GPP

6	Mapping of transport channels to physical channels.....	7428
6.1	Method for mapping of PCH to Secondary CCPCH.....	7528
7	Timing relationship between physical channels.....	8029
	Appendix A: Power Control Timing	8633
	History	8935

Intellectual Property Rights

<IPR notice shall be provided once correct notice is available within 3GPP>

Foreword

This Technical Specification has been produced by the 3rd Generation Partnership Project, Technical Specification Group Radio Access Network, Working Group 1 (3GPP TSG RAN WG1).

The contents of this TS may be subject to continuing work within the 3GPP and may change following formal TSG approval. Should the TSG modify the contents of this TS, it will be re-released with an identifying change of release date and an increase in version number as follows:

Version m.x.y



3GPP

where:

m indicates [major version number]

x the second digit is incremented for all changes of substance, i.e. technical enhancements, corrections, updates, etc.

y the third digit is incremented when editorial only changes have been incorporated into the specification.

1 Scope

This specification describes the characteristics of the Layer 1 transport channels and physical channels in the FDD mode of UTRA. The main objectives of the document are to be a part of the full description of the UTRA Layer 1, and to serve as a basis for the drafting of the actual technical specification (TS).

2 References

The following documents contain provisions which, through reference in this text, constitute provisions of the present document.

<Editor's Note: Relevant references should be discussed>

[1] TS S1.02 (V1.1.0): "Physical layer - general description"

The logo for 3GPP (3rd Generation Partnership Project) is displayed in a large, bold, black serif font in the upper right corner of a large rectangular frame.

[2] TS S1.02 (V1.0.0): "UE physical layer capabilities"

- [3] TS S1.11 (V1.1.0): “Physical channels and mapping of transport channels onto physical channels (FDD)”
 - [4] TS S1.12 (V1.0.0): “Multiplexing and channel coding (FDD)”
 - [5] TS S1.13 (V1.0.0): “Spreading and modulation (FDD)”
 - [6] TS S1.14 (V1.1.0): “Physical layer procedures (FDD)”
 - [7] TS S1.21 (V1.1.0): “Transport channels and physical channels (TDD)”
 - [8] TS S1.22 (V1.0.0): “Multiplexing and channel coding (TDD)”
 - [9] TS S1.23 (V1.1.0): “Spreading and modulation (TDD)”
 - [10] TS S1.24 (V1.1.0): “Physical layer procedures (TDD)”
 - [11] TS S1.31 (V0.1.0): “Measurements”
 - [12] TS S2.01 (V1.0.0): “Radio Interface Protocol Architecture”
-

3 Definitions, symbols and abbreviations

3.1 Definitions

For the purposes of the present document, the [following] terms and definitions [given in ... and the following] apply.

3GPP

<defined term>: <definition>.

example: text used to clarify abstract rules by applying them literally.

3.2 Symbols

For the purposes of the present document, the following symbols apply:

<symbol> <Explanation>

3.3 Abbreviations

For the purposes of the present document, the following abbreviations apply:

<ACRONYM> <Explanation>

AICH	Acquisition Indication Channel
BCH	Broadcast Channel
CCPCH	Common Control Physical Channel
DCH	Dedicated Channel
DPCCH	Dedicated Physical Control Channel
DPCH	Dedicated Physical Channel
DPDCH	Dedicated Physical Data Channel
DSCH	Downlink Shared Channel

3GPP

FACH Forward Access Channel

[FAUSCH	Fast Uplink Signalling Channel]
FBI	Feedback Information
MUI	Mobile User Identifier
PCH	Paging Channel
PDSCH	Physical Downlink Shared Channel
PI	Paging Indication
PRACH	Physical Random Access Channel
PSCCCH	Physical Shared Channel Control Channel
RACH	Random Access Channel
RNC	Radio Network Controller
SCH	Synchronisation Channel
SF	Spreading Factor
SFN	System Frame Number
STTD	Space Time Transmit Diversity
TFCI	Transport Format Combination Indicator
TPC	Transmit Power Control
UE	User Equipment

3GPP

4 Transport channels

<Editors note: FAUSCH will not be included in the first release. The text describing FAUSCH is retained in [] in S1.11 until it can be moved to some other document.>

Transport channels are the services offered by Layer 1 to the higher layers.

A transport channel is defined by how and with what characteristics data is transferred over the air interface. A general classification of transport channels is into two groups:

- Common Channels (where there is a need for in-band identification of the UEs when particular UEs are addressed)
- Dedicated Channels (where the UEs are identified by the physical channel, i.e. code and frequency)

General concepts about transport channels are described in 3GPP RAN S2.02 (L2 specification).

4.1 Dedicated transport channels

There exists only one type of dedicated transport channel, the Dedicated Channel (DCH).

The logo for 3GPP, consisting of the letters '3GPP' in a bold, serif font.

[There are two types of dedicated transport channel, the Dedicated Channel (DCH) and the Fast Uplink Signalling Channel (FAUSCH).]

4.1.1 DCH – Dedicated Channel

The Dedicated Channel (DCH) is a downlink or uplink transport channel that is used to carry user or control information between the network and the UE. [The DCH thus corresponds to the three channels Dedicated Traffic Channel (DTCH), Stand-Alone Dedicated Control Channel (SDCCH), and Associated Control Channel (ACCH) defined within ITU-R M.1035.] The DCH is transmitted over the entire cell or over only a part of the cell using lobe-forming antennas. The Dedicated Channel (DCH) is characterized by the possibility of fast rate change (every 10ms), fast power control and inherent addressing of UEs.

4.1.2 [FAUSCH – Fast Uplink Signalling Channel]

<Editors note:Not included in the first release.>

[The Fast Uplink Signalling Channel (FAUSCH) is an optional uplink transport channel that is used to carry control information from a UE. The FAUSCH is always received from the entire cell.]

4.2 Common transport channels

There are six types of common transport channels: BCH, FACH, PCH, RACH, DSCH, and DSCH

The logo for 3GPP (3rd Generation Partnership Project) is displayed in a large, bold, black serif font in the top right corner of a large rectangular frame.

control channel.

4.2.1 BCH – Broadcast Channel

The Broadcast Channel (BCH) is a downlink transport channel that is used to broadcast system- and cell-specific information. The BCH is always transmitted over the entire cell with a low fixed bit rate.

4.2.2 FACH – Forward Access Channel

The Forward Access Channel (FACH) is a downlink transport channel that is used to carry control information to a UE when the system knows the location cell of the UE. The FACH may also carry short user packets. The FACH is transmitted over the entire cell or over only a part of the cell using lobe-forming antennas. The FACH uses slow power control and requires in-band identification of the UEs.

4.2.3 PCH – Paging Channel

The Paging Channel (PCH) is a downlink transport channel that is used to carry control information to a UE when the system does not know the location cell of the UE. The PCH is always transmitted over the entire cell. The PCH is designed to support efficient sleep mode procedures.

4.2.4 RACH – Random Access Channel

The Random Access Channel (RACH) is an uplink transport channel that is used to carry control information from the UE. The RACH may also carry short user packets. The RACH is always received

3GPP

from the entire cell. The RACH is characterized by a collision risk and by the use of open loop power control.

4.2.5 DSCH – Downlink Shared Channel

The downlink shared channel (DSCH) is a downlink transport channel shared by several UEs carrying dedicated control or traffic data.

Two possibilities exist for the DSCH:

- the DSCH is associated with a DCH,
- the DSCH is associated with a DSCH control channel.

It is for further study whether both possibilities are needed.

4.2.6 DSCH Control Channel

The DSCH control channel is a downlink transport channel carrying control information to the UE for operating the DSCH when not associated with a DCH. Such control information corresponds among other things to resource allocation messages and L1 control information such as TPC, that are not available on the DSCH.

3GPP

5 Physical channels

Physical channels typically consist of a three-layer structure of superframes, radio frames, and time slots, although this is not true for all physical channels. Depending on the symbol rate of the physical channel, the configuration of radio frames or time slots varies.

- Superframe : A Superframe has a duration of 720ms and consists of 72 radio frames. The superframe boundaries are defined by the System Frame Number (SFN):
 - The head radio frame of superframe : $SFN \bmod 72=0$.
 - The tail radio frame of superframe: $SFN \bmod 72=71$.
- Radio frame : A Radio frame is a processing unit which consists of 16 time slots.
- Time slot : A Time slot is a unit which consists of the set of information symbols. The number of symbols per time slot depends on the physical channel.
- Symbol : One symbol consists of a number of chips. The number of chips per symbol is equivalent to the spreading factor of the physical channel.

3GPP

5.1 The physical resource

The basic physical resource is the code/frequency plane. In addition, on the uplink, different information streams may be transmitted on the I and Q branch. Consequently, a physical channel corresponds to a specific carrier frequency, code, and, on the uplink, relative phase (0 or $\pi/2$).

5.2 Uplink physical channels

5.2.1 Dedicated uplink physical channels

There are two types of uplink dedicated physical channels, the uplink Dedicated Physical Data Channel (uplink DPDCH) and the uplink Dedicated Physical Control Channel (uplink DPCCH).

The DPDCH and the DPCCH are I/Q code multiplexed within each radio frame (see S1.13).

The uplink DPDCH is used to carry dedicated data generated at Layer 2 and above, i.e. the dedicated transport channel (DCH). There may be zero, one, or several uplink DPDCHs on each Layer 1 connection.

The uplink DPCCH is used to carry control information generated at Layer 1. The Layer 1 control information consists of known pilot bits to support channel estimation for coherent detection, transmit power-control (TPC) commands, feedback information (FBI), and an optional transport-format combination indicator (TFCI). The transport-format combination indicator informs the receiver about the instantaneous parameters of the different transport channels multiplexed on the uplink DPDCH, and corresponds to the data transmitted in the same frame. It is the UTRAN that determines if a TFCI should be transmitted, hence making it mandatory for all UEs to support the use of TFCI in the uplink. There is one and only one uplink DPCCH on each Layer 1 connection.

Figure 1 shows the frame structure of the uplink dedicated physical channels. A radio frame length 10 ms is split into 16 slots, each of length $T_{\text{slot}} = 0.625$ ms, corresponding to one power-control period. A super frame corresponds to 72 consecutive frames, i.e. the super-frame length is 720 ms.

3GPP

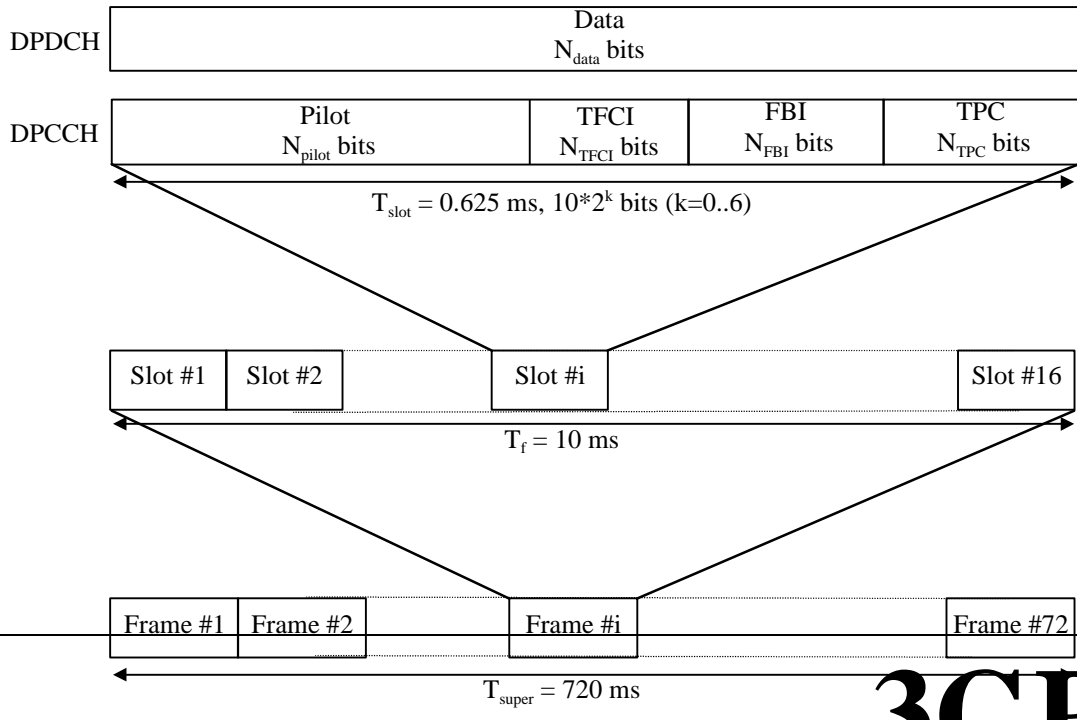

3GPP

Figure 14: Frame structure for uplink DPDCH/DPCCH.

The parameter k in Figure 11~~Figure 1~~ determines the number of bits per uplink DPDCH/DPCCH slot. It is related to the spreading factor SF of the physical channel as $SF = 256/2^k$. The spreading factor may thus range from 256 down to 4. Note that an uplink DPDCH and uplink DPCCH on the same Layer 1 connection generally are of different rates, i.e. have different spreading factors and different values of k .

The exact number of bits of the different uplink DPCCH fields in Figure 11~~Figure 1~~ (N_{pilot} , N_{TPC} , N_{FBI} , and N_{TFCI}) is yet to be determined. The field order is fixed. A limited set of field combinations will be defined.

<Editors note: See Adhoc #7: The spreading factor for the DPCCH fields and the length (in bits) of each field is negotiated at connection set up. Both the spreading factor and the length of the fields may be negotiated during the connection through higher layer signalling.>

The N_{FBI} bits are used to support techniques requiring feedback between the UE and the UTRAN Access Point (=cell transceiver), including feedback (FB) mode transmit diversity and site selection diversity. The exact details of the FBI field in the frame structure shown in Figure 11~~Figure 1~~ are for further study.

The values for the number of bits per field are given in Table 1~~Table 1~~ and Table 2~~Table 2~~. The channel bit and symbol rates given in Table 1~~Table 1~~ are the rates immediately before spreading. The

3GPP

pilot patterns are given in Table 3~~Table 3~~ and the TPC bit pattern is given in Table 4~~Table 4~~.

Table 14: DPDCH fields

Channel Bit Rate (kbps)	Channel Symbol Rate (ksps)	SF	Bits/ Frame	Bits/ Slot	N _{data}
16	16	256	160	10	10
32	32	128	320	20	20
64	64	64	640	40	40
128	128	32	1280	80	80
256	256	16	2560	160	160
512	512	8	5120	320	320
1024	1024	4	10240	640	640

There are two types of Uplink Dedicated Physical Channels; those that include TFCI(e.g. for several simultaneous services) and those that do not include TFCI(e.g. for fixed-rate services). These types are reflected by the duplicated rows of Table 2Table-2. The channel bit and symbol rates given in Table 2Table-2 are the rates immediately before spreading.

<Editors note: Details on the FBI field are FFS. See Adhoc 6 and 7.>

3GPP

Table 22: DPCCH fields

Channel Bit Rate (kbps)	Channel Symbol Rate (ksps)	SF	Bits/ Frame	Bits/ Slot	N_{pilot}	N_{TPC}	N_{TFCI}	N_{FBI}
16	16	256	160	10	6	2	2	0
16	16	256	160	10	8	2	0	0
16	16	256	160	10	5	2	2	1
16	16	256	160	10	7	2	0	1
16	16	256	160	10	[6]	[2]	[0]	[2]
16	16	256	160	10	[5]	[1]	[2]	[2]

The pilot bit pattern is described in Table 3. The shadowed part can be used as frame synchronization words. (The value of the pilot bit other than the frame synchronization word shall be “1”.)

<Editors note: Pilot patterns for N_{pilot} other than 6,8 are TBD.>

3GPP

Table 33: Pilot bit pattern

	$N_{\text{pilot}} = 6$						$N_{\text{pilot}} = 8$							
Bit #	0	1	2	3	4	5	0	1	2	3	4	5	6	7

3GPP

3GPP

Slot #1	1	1	1	1	1	1	1	1	1	1	1	1	1
2	1	1	1	1	0	1	1	1	1	1	0	1	1
3	1	0	1	1	0	1	1	0	1	1	0	1	1
4	1	1	0	1	0	1	1	1	0	1	0	1	1
5	1	1	0	1	1	1	1	1	0	1	1	1	1

The relationship between the TPC bit pattern and transmitter power control command amount is presented in Table 4.

TPC bits are allowed to be punctured. The UE can utilize the vacant bits given by the puncturing in order to send control information to BTS.

Table 44: TPC Bit Pattern

TPC Bit Pattern	Transmitter power control command
11	1
00	0

In each radio frame, the TFCI value corresponds to a certain combination of bit rates of the DCHs currently in use. This correspondence is (re-)negotiated at each DCH addition/removal. For default TFCI there is one code word of length 32 bits. For extended TFCI there are 2 code words of length 16 bits giving the same total number of encoded TFCI bits per frame as for default TFCI. The 32 encoded TFCI bits are divided evenly among the 16 time slots, 2 bits per slot.

Multi-code operation is possible for the uplink dedicated physical channels. When multi-code

3GPP

transmission is used, several parallel DPDCH are transmitted using different channelization codes, see S1.13. However, there is only one DPCCH per connection.

5.2.2 Common uplink physical channels

5.2.2.1 Physical Random Access Channel

The Physical Random Access Channel (PRACH) is used to carry the RACH.

[The Physical Random Access Channel (PRACH) is used to carry the RACH and the FAUSCH.]

5.2.2.1.1 RACH transmission

The random-access transmission is based on a Slotted ALOHA approach with fast acquisition indication. The UE can start the transmission at a number of well-defined time-offsets, relative to the frame boundary of the received BCH of the current cell. The different time offsets are denoted *access slots* and are spaced 1.25 ms apart as illustrated in Figure 2. Information on what access slots are available in the current cell is broadcast on the BCH.

3GPP

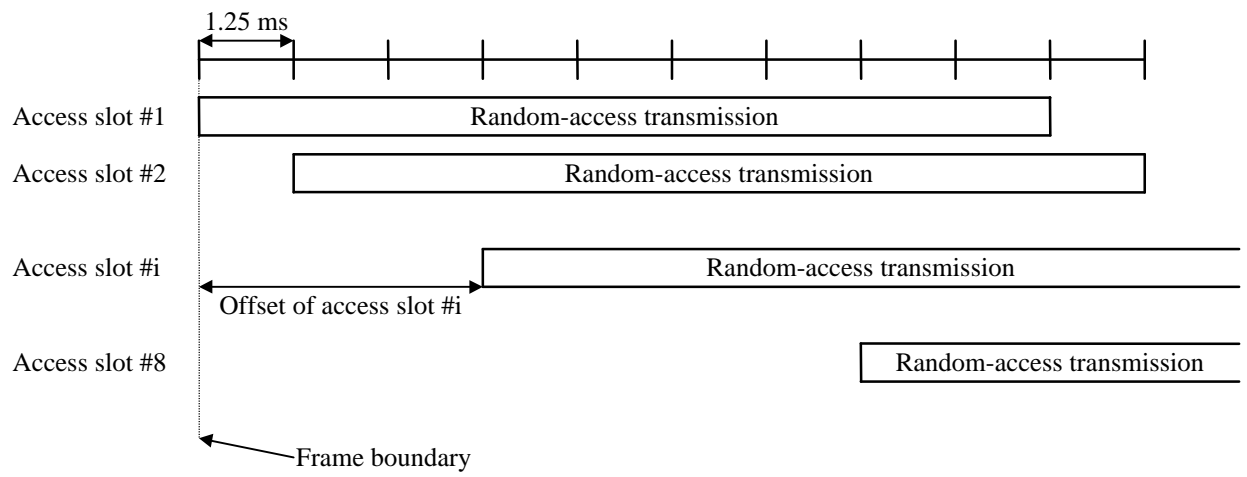

Figure 22: PRACH allocated for RACH access slots.

The structure of the random-access transmission of Figure 22, is shown in Figure 3.

3GPP

The random-access transmission consists of one or several *preambles* of length 1 ms and a *message* of length 10 ms.

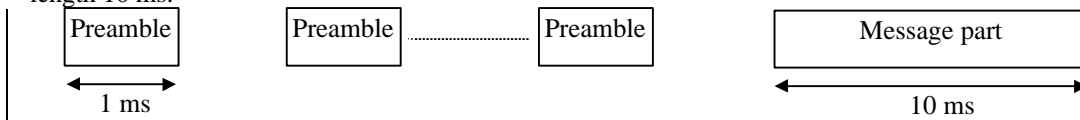

Figure 33: Structure of the random-access transmission.

5.2.2.1.2 RACH preamble part

The preamble part of the random-access burst consists of a *signature* of length 16 complex symbols $\pm 1(+j)$. Each preamble symbol is spread with a 256 chip real Orthogonal Gold code. There are a total of 16 different signatures, based on the Orthogonal Gold code set of length 16 (see S1.13 for more details).

3GPP

5.2.2.1.3 RACH message part

The message part of the random-access burst has the same structure as the uplink dedicated physical channel. It consists of a data part, corresponding to the uplink DPDCH, and a Layer 1 control part, corresponding to the uplink DPCCH, see

Figure 4

Figure 4. The data and control parts are transmitted in parallel. The data part carries the random access request or user packet. The spreading factor of the data part is limited to $SF \in \{256, 128, 64, 32\}$ corresponding to channel bit rates of 16, 32, 64, and 128 kbps respectively. The control part carries pilot bits and rate information, using a spreading factor of 256. The rate information indicates which channelization code (or rather the spreading factor of the channelization code) is used on the data part (see further in S1.13).

3GPP

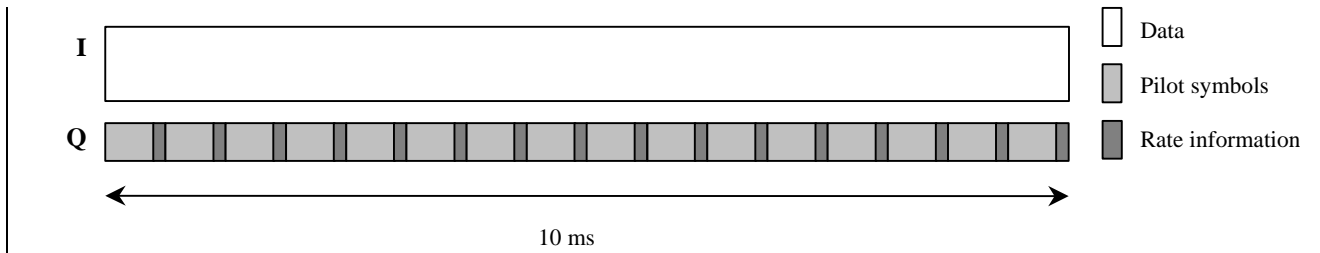

Figure 44: The message part of the random-access burst.

<Editors note: Figure 5, Tables 5 and 6 describe the RACH message part in more detail. To be confirmed.>

3GPP

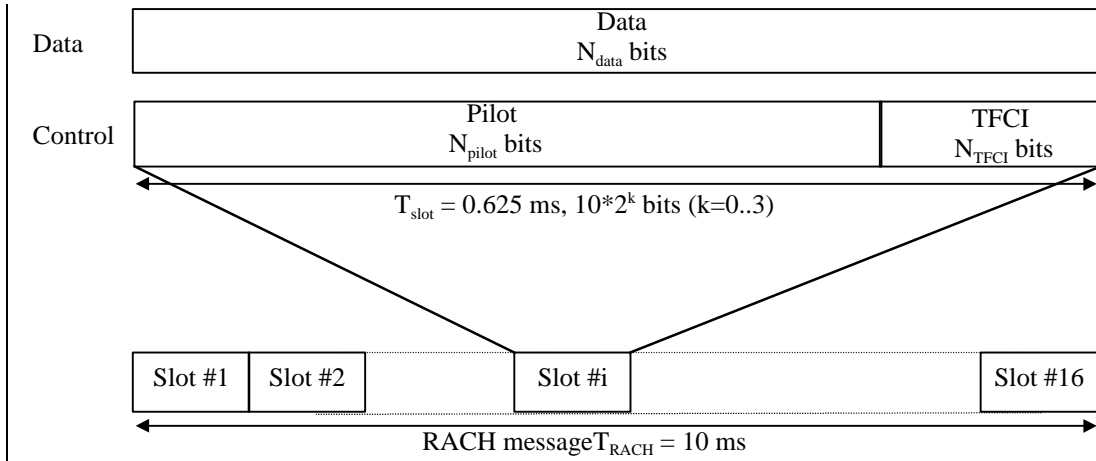

Figure 55: The message part of the random-access burst.

3GPP

Table 55: RACH message Data fields

Channel Bit Rate (kbps)	Channel Symbol Rate (ksps)	SF	Bits/ Frame	Bits/ Slot	N_{data}
16	16	256	160	10	10
32	32	128	320	20	20
64	64	64	640	40	40
128	128	32	1280	80	80

Table 66: -RACH message Data fields

Channel Bit Rate (kbps)	Channel Symbol Rate (ksps)	SF	Bits/ Frame	Bits/ Slot	N_{pilot}	N_{TFCI}
16	16	256	160	10	8	2

5.2.2.1.4 [FAUSCH transmission]

<Editors note: FAUSCH will not be included in the first release.>

3GPP

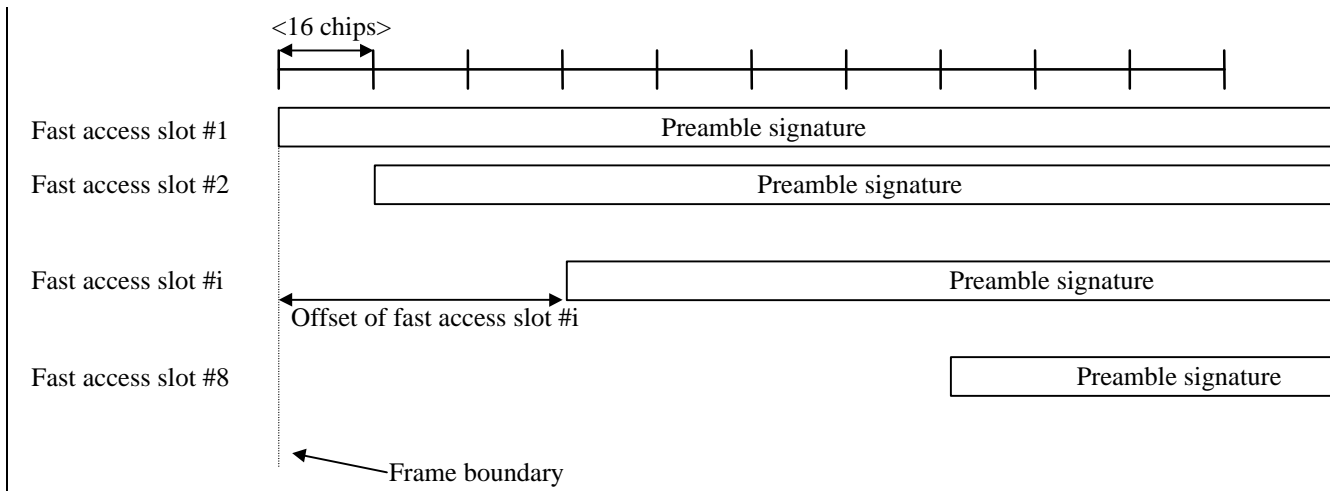

Figure 66: PRACH used for FAUSCH fast access slots.

3GPP

[The Fast Uplink Physical Channel (FAUSCH) is based on the transmission of a signature of length 16 complex symbols $\pm(1+j)$. The signature is one of the set of signatures used for the RACH preamble. Signature no.[8] is selected because it has the best correlation properties. Each symbol is spread with a 256 chip real Orthogonal Gold code. A time slot is allocated to the UE by the network when entering Connected Mode but the allocation may be updated with appropriate signalling. To avoid the possibility of collisions only one UE is allowed to transmit with a given signature in a particular time slot. Thus the UE can start the transmission of the FAUSCH at an assigned time offset relative to the frame boundary of the received BCH of the current cell. The different time offsets are denoted *fast access slots* and are spaced [16] chips apart as illustrated in Figure 5. To avoid possible confusion of transmissions from different UEs the separation between allocations of fast access slots to different UEs must be sufficient to allow for any round-trip delay resulting from the physical distance between network and UE. Therefore the allocation of fast access slots may be limited by the network to a subset of those available, depending on the deployment scenario.]

5.2.2.1.5 [Sharing of PRACH by RACH and FAUSCH]

<Editors note: FAUSCH will not be included in the first release.>

[FAUSCH uses only the preamble part of PRACH. The RACH and FAUSCH transmissions could use different Gold Codes for spreading the signatures, but the complexity of the uplink receiver is significantly reduced if the same Gold Code is used. Low interference between RACH and FAUSCH

The logo for 3GPP (3rd Generation Partnership Project) is displayed in a large, bold, black serif font. It is positioned in the upper right corner of a large, empty rectangular frame that occupies the lower half of the page.

can then be achieved by restricting the allocation of RACH access slots and FAUSCH fast access slots

so that the respective transmissions occur in different parts of the 10 ms frame. The partitioning of the frame is flexible. For example, if RACH access slots are spaced 2.5 ms apart, then FAUSCH fast access slots could be allocated in the gaps. The UE can determine the available RACH access slots by monitoring the BCH. The FAUSCH fast access slots are individually allocated to a specific UE.]

5.3 Downlink physical channels

5.3.1 Downlink Transmit Diversity

Table 7 summarizes the possible application of open and closed loop Transmit diversity modes on different downlink physical channels.

3GPP

Table 77: Application of Tx diversity modes on downlink physical channels.

Channel	Open loop mode	Closed loop mode	Note
PCCPCH	X	N/A	STTD applied only to data symbols
SCH	N/A*	N/A	A proposal to use TSTD on SCH is presented in TSGR1#3(99)152
SCCPCH	X	N/A	
DPCH	X	X	
DPCH (in SHO)	X	N/A	
DPCH (in SHO and using SSDT power control)	X*	N/A*	
PDSCH (associated with DPCH)	X	X	
PDSCH (associated with PSCCCH)	X*	X*	
PSCCCH	X*	N/A	

3GPP

AICH	X	N/A	Only if closed loop Tx diversity is used in the cell and/or open loop mode is used on PCCPCH
------	---	-----	--

N/A = Not applied

X = Can be applied

X* = Can be applied but requires further studies (working assumption)

N/A* = Not applied but requires further studies (working assumption)

5.3.1.1 Open loop transmit diversity

5.3.1.1.1 Space time block coding based transmit antenna diversity (STTD)

The open loop downlink transmit diversity employs a space time block coding based transmit diversity (STTD). The STTD encoding is used optionally at the base station. Its use at the mobile is mandatory.

A block diagram of the transmitter and a generic STTD encoder are shown in the Figure 7 and Figure 8 below. Channel coding, rate matching and interleaving is done as in the non-diversity mode.

3GPP

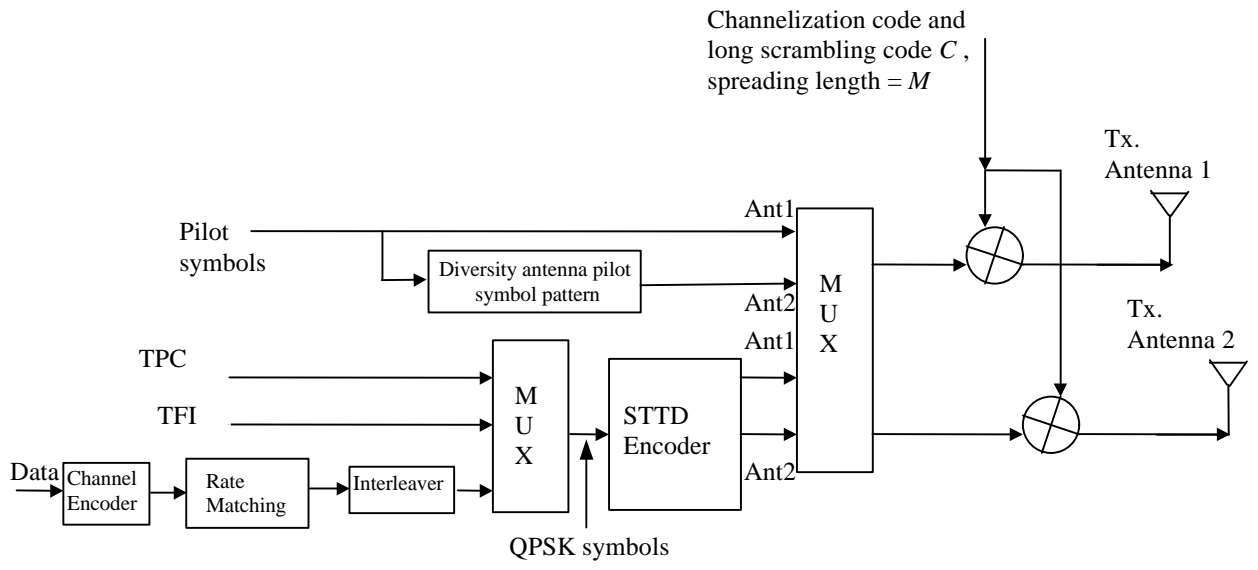

3GPP

Figure 77: Block diagram of the transmitter (STTD).

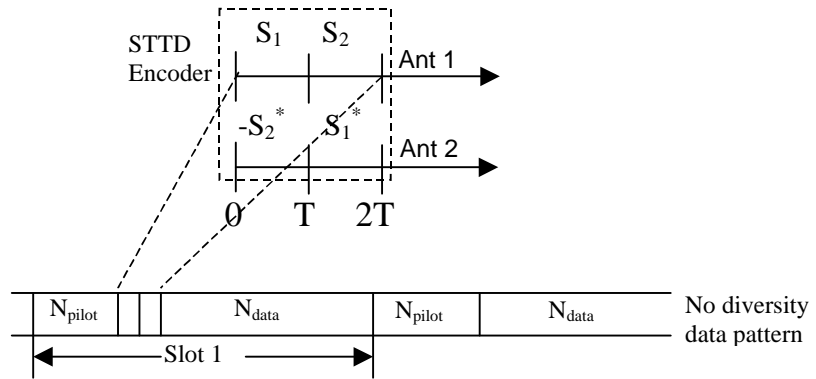

Figure 88: Block diagram of STTD encoder. The symbols S_1 , S_2 are QPSK symbols and T denotes the symbol time.

3GPP

5.3.2 Dedicated downlink physical channels

There is only one type of downlink dedicated physical channel, the Downlink Dedicated Physical Channel (downlink DPCH).

Within one downlink DPCH, dedicated data generated at Layer 2 and above, i.e. the dedicated transport channel (DCH), is transmitted in time-multiplex with control information generated at Layer 1 (known pilot bits, TPC commands, and an optional TFCI). The downlink DPCH can thus be seen as a time multiplex of a downlink DPDCH and a downlink DPCCH, compare Section 5.2.1. It is the UTRAN that determines if a TFCI should be transmitted, hence making it mandatory for all UEs to support the use of TFCI in the downlink.

Figure 9 shows the frame structure of the downlink DPCH. Each frame of length 10 ms is split into 16 slots, each of length $T_{\text{slot}} = 0.625$ ms, corresponding to one power-control period. A super frame corresponds to 72 consecutive frames, i.e. the super-frame length is 720 ms.

3GPP

3GPP

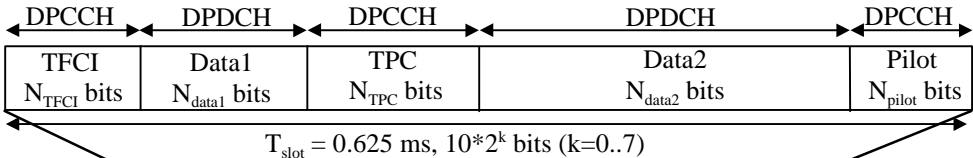

Figure 99: Frame structure for downlink DPCH.

The parameter k in Figure 99 determines the total number of bits per downlink DPCH slot. It is related to the spreading factor SF of the physical channel as $SF = 512/2^k$. The spreading factor may thus range from 512 down to 4.

The exact number of bits of the different downlink DPCH fields in Figure 99 (N_{pilot} , N_{TPC} , N_{TFCI} , N_{data1} and N_{data2}) is yet to be determined. The overhead due to the DPCCH transmission has to be negotiated at the connection set-up and can be re-negotiated during the communication, in order to match particular propagation conditions.

The DPCCH fields are spread using the same channelization code used for the DPDCH field. A channelization code for the highest bit rate to be served during the connection (for a given DPCH) should be assigned (with spreading factor SF_1).

Table 8 shows the number of bits per slot of the various fields. There are basically two types of downlink Dedicated Physical Channel; those that include TFCI (e.g. for several simultaneous services) and those that do not include TFCI (e.g. for fixed-rate services). These types are reflected by the duplicated rows of Table 8. The channel bit and symbol rates given in Table 8 are the rates immediately before spreading.

3GPP

Table 88: DPDCH and DPCCH fields

Channel Bit Rate (kbps)	Channel Symbol Rate (ksps)	SF	Bits/Frame			Bits/Slot	DPDCH Bits/Slot		DPCCH Bits/Slot		
			DPDCH	DPCCH	TOT		N _{Data1}	N _{Data2}	N _{TFCI}	N _{TPC}	N _{Pilot}
16	8	512	64	96	160	10	2	2	0	2	4
16	8	512	32	128	160	10	0	2	2	2	4
32	16	256	160	160	320	20	2	8	0	2	8
32	16	256	128	192	320	20	0	8	2	2	8
64	32	128	480	160	640	40	6	24	0	2	8
64	32	128	448	192	640	40	4	24	2	2	8
128	64	64	1120	160	1280	80	14	56	0	2	8
128	64	64	992	288	1280	80	6	56	8	2	8
256	128	32	2400	160	2560	160	30	120	0	2	8
256	128	32	2272	288	2560	160	22	120	8	2	8

3GPP

512	256	16	4832	288	5120	320	62	240	0	2	16
-----	-----	----	------	-----	------	-----	----	-----	---	---	----

512	256	16	4704	416	5120	320	54	240	8	2	16
1024	512	8	9952	288	10240	640	126	496	0	2	16
1024	512	8	9824	416	10240	640	118	496	8	2	16
2048	1024	4	20192	288	20480	1280	254	1008	0	2	16
2048	1024	4	20064	416	20480	1280	246	1008	8	2	16

Note: This table assumes the chip rate 4.096 Mcps i.e. it does not cover other chip rates such as 8.192 Mcps.

The pilot symbol pattern is described in Table 9. The shadowed part can be used as frame synchronization words. (The symbol pattern of the pilot symbols other than the frame synchronization word shall be "11".) In Table 9, the transmission order is from left to right. (Each two-bit pair represents an I/Q pair of QPSK modulation.)

3GPP

Table 99: Pilot Symbol Pattern

Symbol #	$N_{\text{pilot}} = 4$		$N_{\text{pilot}} = 8$				$N_{\text{pilot}} = 16$							
	0	1	0	1	2	3	0	1	2	3	4	5	6	7
Slot # 1	11	11	11	11	11	11	11	11	11	11	11	11	11	10
2	11	11	11	11	11	01	11	10	11	10	11	10	11	01
3	11	10	11	01	11	01	11	10	11	01	11	11	11	01
4	11	01	11	10	11	01	11	11	11	01	11	00	11	10
5	11	10	11	10	11	11	11	11	11	00	11	01	11	10
6	11	10	11	10	11	11	11	11	11	11	11	01	11	10
7	11	01	11	01	11	00	11	10	11	11	11	01	11	10
8	11	00	11	10	11	01	11	01	11	00	11	10	11	00
9	11	00	11	11	11	00	11	11	11	10	11	00	11	01
10	11	10	11	01	11	01	11	01	11	11	11	11	11	00
11	11	10	11	11	11	10	11	10	11	10	11	11	11	10
12	11	11	11	01	11	01	11	01	11	10	11	10	11	00
13	11	10	11	00	11	01	11	10	11	01	11	11	11	10
14	11	11	11	10	11	00	11	00	11	10	11	10	11	00
15	11	00	11	01	11	00	11	01	11	10	11	00	11	00
16	11	00	11	00	11	00	11	10	11	00	11	00	11	00

3GPP

The relationship between the TPC symbol and the transmitter power control command is presented in Table 10.

Table 10: TPC Bit Pattern

TPC Symbol	Transmitter power control command
11	1
00	0

In each radio frame, the TFCI value corresponds to a certain combination of bit rates of the DCHs currently in use. This correspondence is (re-)negotiated at each DCH addition/removal. For default TFCI there is one code word of length 32 bits. For extended TFCI there are 2 code words of length 16 bits giving the same total number of encoded TFCI bits per frame as for default TFCI. The 32 encoded TFCI bits are divided evenly among the 16 time slots, 2 bits per slot. At the channel bit rates higher than 64 ksps, each 2-bit pair is repeated four times.

<Editors note: DL Multicode transmission>

When the total bit rate to be transmitted on one downlink connection exceeds the maximum bit rate for a downlink physical channel, multicode transmission is employed, i.e. several parallel downlink DPCHs

3GPP

are transmitted for one connection using the same spreading factor. In this case, the Layer 1 control

information is put on only the first downlink DPCH. The additional downlink DPCHs belonging to the connection do not transmit any data during the corresponding time period, see Figure 10. Multiple codes may also be transmitted in order to transmit different transport channels on different codes (code multiplex). In that case, the different parallel codes may have different spreading factors and the Layer 1 control information is transmitted on each code independently.

3GPP

3GPP

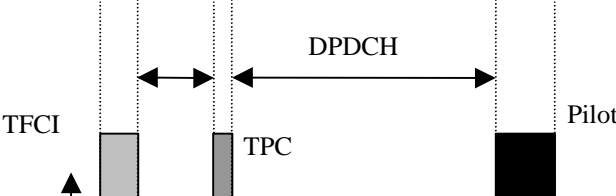

Figure 1040: Downlink slot format in case of multi-code transmission.

5.3.2.1 STTD for DPCH

The block diagrams shown in Figure 77 Figure 7 and Figure 88 Figure 8 are used to STTD encode the DPDCH, TPC and TFCI symbols. The pilot symbol pattern for the DPCH channel transmitted on the diversity antenna is given in Table 11 Table 11.

3GPP

Table 1144: Pilot pattern of the DPCH channel for the diversity antenna using STTD.

	$N_{\text{pilot}} = 4$		$N_{\text{pilot}} = 8$				$N_{\text{pilot}} = 16$							
Symbol #	0	1	0	1	2	3	0	1	2	3	4	5	6	7

3GPP

3GPP

Slot # 1	01	10	11	01	00	10	11	01	00	10	11	00	00	10
2	01	10	11	11	00	10	11	00	00	11	11	11	00	11
3	00	10	11	11	00	00	11	11	00	11	11	11	00	10
4	11	10	11	11	00	11	11	11	00	10	11	00	00	01
5	00	10	11	01	00	11	11	10	00	10	11	00	00	00

At call setup phase the UE is informed if Transmit diversity will be used on DPCH or not. If the base station allows diversity mode, the base station starts the transmission of dedicated physical channel(s) using open loop diversity mode by default. As soon as the reverse link transmission has started, the base station can command the UE to either use open loop diversity mode or feedback mode by using higher level signaling. During hand over between cells and sectors open loop antenna diversity is used on dedicated physical channels.

5.3.2.2 Dedicated channel pilots with feedback mode transmit diversity

For certain sub-modes of feedback mode transmit diversity, in which transmission antennas are selected, the pilot patterns can be varied according to which antenna is transmitted upon (see Figure 11-11 a, where the different shading indicates different pilot patterns). This assists in some types of antenna verification. Pilot symbol patterns are TBD. Otherwise, the pilot symbol patterns from both of the antennas are the same (see Figure 11-11 b).

3GPP

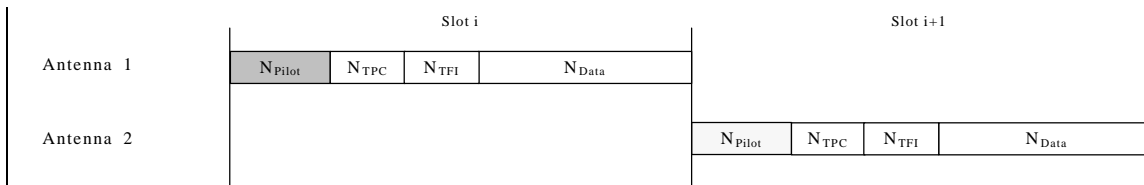

(a)

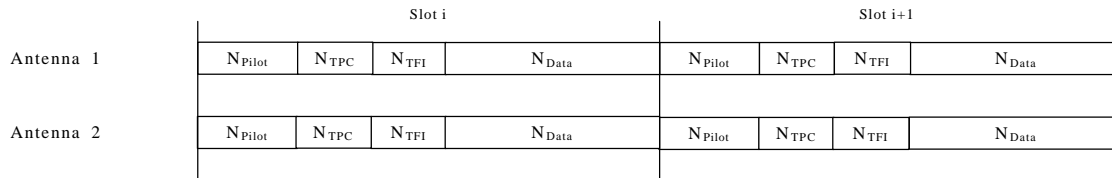

(b)

3GPP

Figure 1144: Slot structures for downlink dedicated physical channel diversity transmission. Structure (a) may be used in conjunction with antenna verification. Structure (b) is used otherwise.

<Editors note: FB diversity does not set any requirements to the length and position of different fields in the DPCH slot structure. The slot structure shown in Figure 8 can be considered as an example.>

5.3.3 Common downlink physical channels

5.3.3.1 Primary Common Control Physical Channel (CCPCH)

The Primary CCPCH is a fixed rate (32 kbps, SF=256) downlink physical channels used to carry the BCH.

Figure 12 shows the frame structure of the Primary CCPCH. The frame structure differs from the downlink DPCH in that no TPC commands or TFCI is transmitted. The only Layer 1 control information is the common pilot bits needed for coherent detection. The Primary CCPCH is not transmitted during the first 256 chips of each slot. Instead, Primary SCH and Secondary SCH are transmitted during this period (see section Synchronisation Channel 5.3.3.3).

3GPP

3GPP

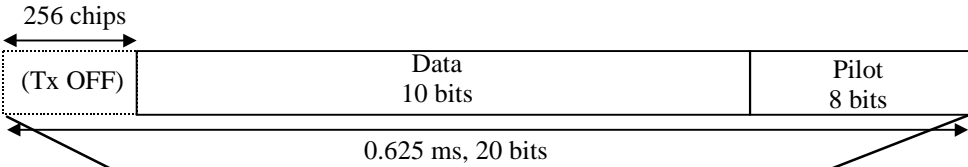

Figure 1242: Frame structure for Primary Common Control Physical Channel.

Table 1242: Pilot Symbol Pattern

Symbol #	0	1	2	3
Slot #1	11	11	11	11
2	11	11	11	01
3	11	01	11	01
4	11	10	11	01
5	11	10	11	11
6	11	10	11	11
7	11	01	11	00
8	11	10	11	01

3GPP

9	11	11	11	00
10	11	01	11	01
11	11	11	11	10
12	11	01	11	01
13	11	00	11	01
14	11	10	11	00
15	11	01	11	00
16	11	00	11	00

5.3.3.1.1 Primary CCPCH structure with STTD encoding

In case the diversity antenna is present at the base station and the PCCPCH is to be transmitted using open loop transmit diversity, the data symbols of the PCCPCH are STTD encoded as given in section Space time block coding based transmit antenna diversity (STTD) 5.3.1.1.1, Figure 77 Figure 7 and Figure 88 Figure 8. The diversity antenna pilot symbol pattern for the PCCPCH is given in Table 13 Table 13 below. The base station transmits a L3 message on the broadcast channel (BCH) indicating whether STTD encoding is used for the PCCPCH or not. During power on and hand over between cells

3GPP

the UE determines the presence of STTD encoding on the PCCPCH, by receiving the L3 message or by detecting the diversity antenna pilot symbol pattern.

3GPP

Table 1343: Diversity antenna pilot pattern for PCCPCH

Symbol #	0	1	2	3
----------	---	---	---	---

3GPP

3GPP

Slot # 1	11	11	00	00
2	11	11	00	10
3	11	01	00	10
4	11	10	00	10
5	11	10	00	00

5.3.3.1.2 Primary CCPCH structure with FB mode transmit diversity

If diversity transmission is applied on dedicated forward link channels but STTD encoding is not used on PCCPCH, only the Primary CCPCH pilot is transmitted in parallel from both of the antennas as shown in the Figure 13. Different pilot patterns are applied to the different antennas, indicated in Figure 13 by the difference in shading.

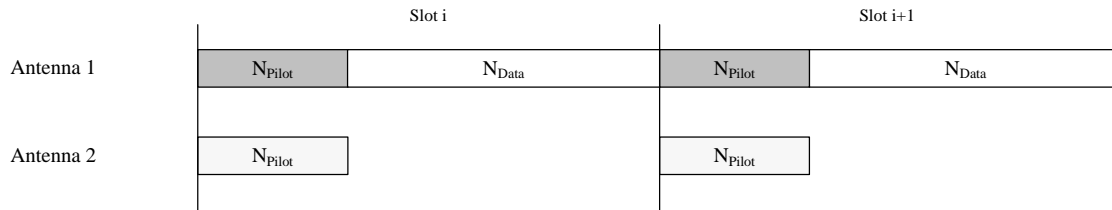

Figure 1343: Slot structure of Primary CCPCH when diversity transmission is applied on dedicated channels.

The diversity antenna pilots are transmitted using the pattern given in Table 1313 above. The

3GPP

transmission power of the pilot signals on both of the antennas are the same.

5.3.3.2 Secondary Common Control Physical Channel

<Editors note: Only the slot format for SF=64 has been specified yet. Other SF are FFS.>

The secondary CCPCH is used to carry the FACH and PCH. It is of constant rate. However, in contrast to the Primary CCPCH, the rate may be different for different secondary CCPCH within one cell and between cells, in order to be able to allocate different amount of FACH and PCH capacity to a cell. The rate and spreading factor of each secondary CCPCH is broadcast on the BCH. The set of possible rates is the same as for the downlink DPCH, see Section Dedicated downlink physical channels 5.3.2.

The frame structure of the Secondary CCPCH is shown in Figure 14 ~~Figure 14~~.

The logo for 3GPP (3rd Generation Partnership Project) is displayed in a large, bold, black serif font in the top right corner of a rectangular frame.

3GPP

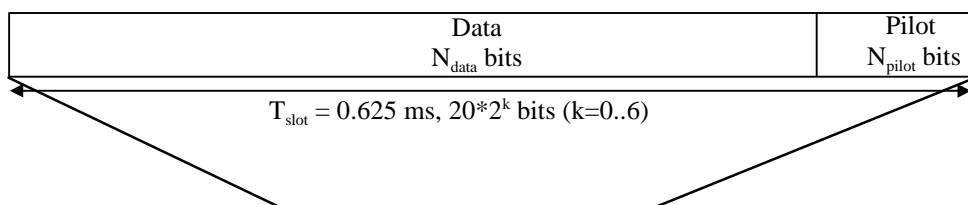

Figure 1444: Frame structure for Secondary Common Control Physical Channel.

The parameter k in Figure 1414Figure-14 determines the total number of bits per downlink Secondary CCPCH slot. It is related to the spreading factor SF of the physical channel as $SF = 256/2^k$. The spreading factor range is from 256 down to 4.

The values for the number of bits per field are given in Table 14Table-14. The channel bit and symbol rates given in Table 14Table-14 are the rates immediately before spreading. The pilot patterns are given in Table 15Table-15.

The FACH and PCH are mapped to separate Secondary CCPCHs. The main difference between a CCPCH and a downlink dedicated physical channel is that a CCPCH is not power controlled. The main difference between the Primary and Secondary CCPCH is that the Primary CCPCH has a fixed predefined rate while the Secondary CCPCH has a constant rate that may be different for different cells, depending on the capacity needed for FACH and PCH. Furthermore, a Primary CCPCH is continuously transmitted over the entire cell while a Secondary CCPCH is only transmitted when there is data available and may be transmitted in a narrow lobe in the same way as a dedicated physical channel (only valid for a Secondary CCPCH carrying the FACH).

The pilot symbol pattern is described in Table 15Table-15. The shadowed part can be used as frame synchronization words. (The symbol pattern of pilot symbols other than the frame synchronization word shall be "11".) In Table 15Table-15, the transmission order is from left to right. (Each two-bit pair

3GPP

represents an I/Q pair of QPSK modulation.)

In the Forward Link Common Physical Channel, it is possible to have burst transmission based on radio frame units. When burst transmission is performed, pilot symbols shall be added to the head of the burst. The number of symbols and the symbol pattern of the pilot symbols to be attached shall take the pattern of Slot #16 in Table 15. The scrambling code phase of the pilot symbol to be added shall have continuous values from the phase of the head of the burst.

Table 1414: Secondary CCPCH fields

Channel Bit Rate (kbps)	Channel Symbol Rate (ksps)	SF	Bits/ Frame	Bits/ Slot	N _{data}	N _{pilot}
32	16	256	320	20		
64	32	128	640	40		
128	64	64	1280	80	72	8
256	128	32	2560	160		
512	256	16	5120	320		
1024	512	8	10240	640		
2048	1024	4	20480	1280		

3GPP

Table 1545: Pilot Symbol Pattern

Symbol #	0	1	2	3
Slot #1	11	11	11	11
2	11	11	11	01
3	11	01	11	01
4	11	10	11	01
5	11	10	11	11
6	11	10	11	11
7	11	01	11	00
8	11	10	11	01

3GPP

9	11	11	11	00
10	11	01	11	01
11	11	11	11	10
12	11	01	11	01
13	11	00	11	01
14	11	10	11	00
15	11	01	11	00
16	11	00	11	00

5.3.3.2.1 Secondary CCPCH structure with STTD encoding

In case the diversity antenna is present at the base station and the SCCPCH is to be transmitted using open loop transmit diversity, the data symbols of the SCCPCH are STTD encoded as given in Section 5.3.1.1.1, Figure 77 Figure 7 and Figure 88 Figure 8. The diversity antenna pilot symbol pattern for the SCCPCH is given in Table 16 Table 16 below.

3GPP

Table 1646: Pilot symbol pattern for the diversity antenna when STTD encoding is used on the SCCPCH.

Symbol #	0	1	2	3
----------	---	---	---	---

3GPP

3GPP

Slot # 1	11	01	00	10
2	11	11	00	10
3	11	11	00	00
4	11	11	00	11
5	11	01	00	11

5.3.3.3 Synchronisation Channel

The Synchronisation Channel (SCH) is a downlink signal used for cell search. The SCH consists of two sub channels, the Primary and Secondary SCH. Figure 15 illustrates the structure of the SCH and the transmission timing relationship with the Primary CCPCH:

3GPP

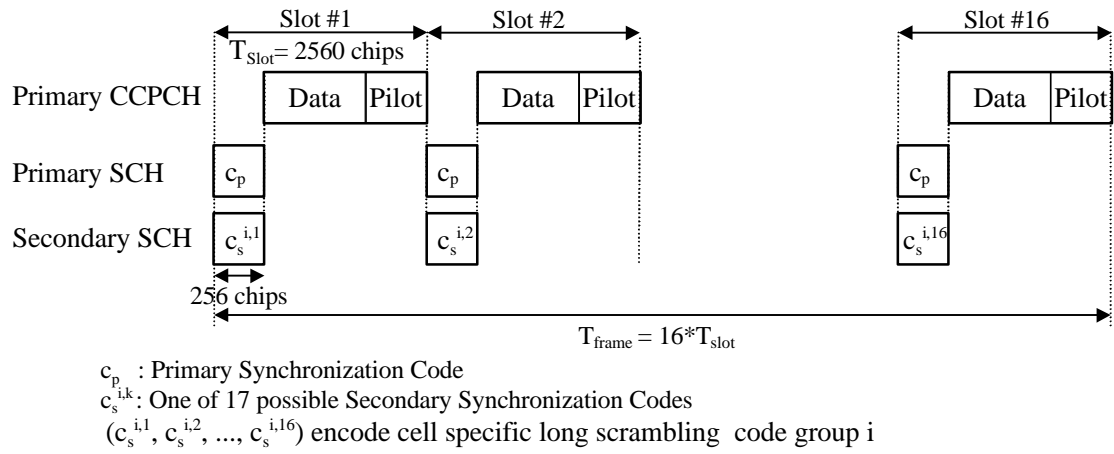

Figure 1545: Structure of Synchronisation Channel (SCH).

3GPP

The Primary SCH consists of an *unmodulated* code of length 256 chips, the Primary Synchronisation Code, transmitted once every slot. The Primary Synchronisation Code is the same for every cell in the system and is transmitted time-aligned with the period where the Primary CCPCH is not transmitted as illustrated in Figure 15 ~~Figure 15~~.

The Secondary SCH consists of repeatedly transmitting a length 16 sequence of *unmodulated* codes of length 256 chips, the Secondary Synchronisation Codes, transmitted in parallel with the Primary Synchronisation channel. Each Secondary Synchronisation code is chosen from a set of 17 different codes of length 256. This sequence on the Secondary SCH indicates which of the 32 different code the cell's downlink scrambling code belongs to. 32 sequences are used to encode the 32 different code groups each containing 16 scrambling codes.

5.3.3.4 Physical Shared Channel Control Channel (PSCCCH)

The frame structure for the PSCCCH is shown in Figure 16 ~~Figure 16~~.

The logo for 3GPP (3rd Generation Partnership Project) is displayed in a large, bold, black serif font in the top right corner of the page.

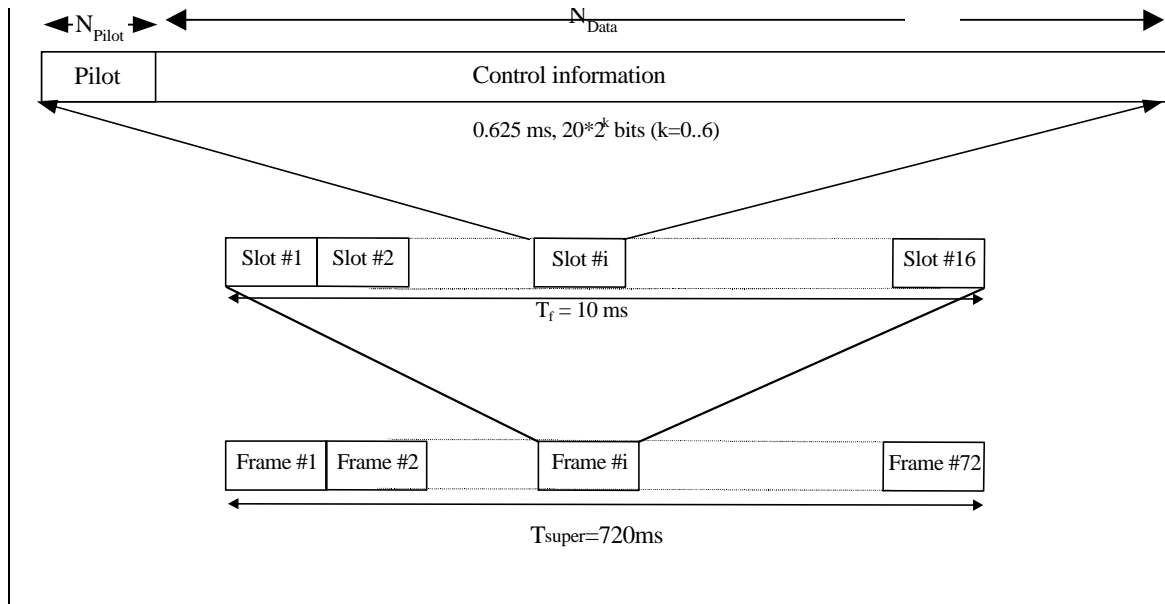

3GPP

Figure 1646: Frame structure of the Physical Shared Channel Control Channel (PSCCCH).

The PSCCCH contains pilot symbols, and a control information field. The control information field can include TPC commands concerning several users. Other control information includes code assignment for the DSCH, but could also comprise other type of information if needed. The TPC commands would come in support of fast closed loop power control of the PDSCH, and thus, would have to be decoded on a slot-by-slot basis. The exact structure of the control information field is for further study.

5.3.3.5 Physical Downlink Shared Channel

The Physical Downlink Shared Channel (PDSCH), used to carry the Downlink Shared Channel (DSCH), is shared by users based on code multiplexing. It is always associated with another physical channel, as follows:

- If the DSCH is associated with a DCH, the PDSCH is associated with a DPCH,
- If the DSCH is associated with a DSCH control channel, the PDSCH is associated with a PSCCCH.

This is described respectively in Sections DSCH associated with a DCH ~~5.3.3.5.1~~ and DSCH associated with a DSCH control channel ~~5.3.3.5.2~~.

In both cases, the PDSCH does not comprise any pilot symbols, since this does not seem to be required

3GPP

at this stage, given information provided on the associated DPCH or PSCCCH. This still needs to be verified.

5.3.3.5.1 DSCH associated with a DCH

The frame structure of the DSCH, when associated with a DCH, is shown on Figure 17.

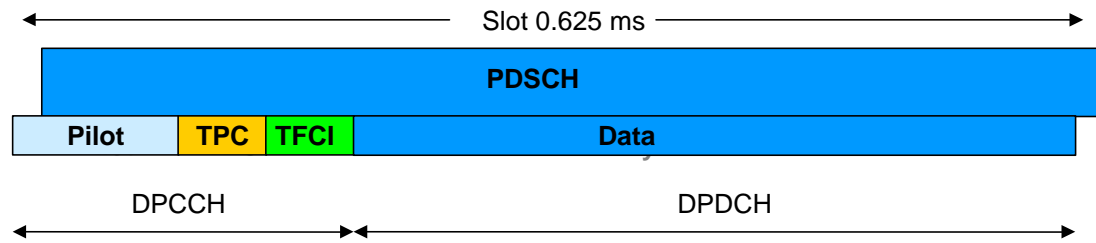

Figure 1747: Frame structure for the DSCH when associated to a DCH.

To indicate for UE that there is data to decode on the DSCH, two signalling methods are possible, either using the TFCI field, or higher layer signalling.

The DSCH transmission with associated DCH is a special case of multicode transmission. The channels do not have necessary the same spreading factor and for DSCH the spreading factor may vary from frame to frame. The relevant Layer 1 control information is transmitted on DCH, the PDSCH does not

3GPP

contain DPCCH information.

For DSCH the allowed spreading factors may vary from 256 to 4. DSCH may consist of multiple parallel codes as well as negotiated at higher layer prior to starting data transmission. In such a case the parallel codes shall be operated with frame synchronization between each other.

5.3.3.5.2 DSCH associated with a DSCH control channel

The frame structure of the DSCH when associated with a DSCH control channel is shown on Figure 18.

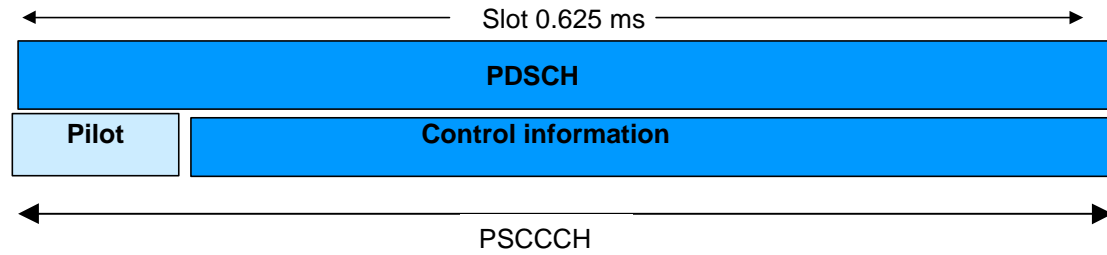

Figure 1848: Frame structure for the DSCH when associated to a DSCH control channel.

3GPP

5.3.3.6 Acquisition Indication Channel (AICH)

The acquisition indication channel (AICH) carries the acquisition indicators. The acquisition indicator AI_i corresponding to signature i is transmitted on the downlink, as a response to the detection of signature i on a PRACH. AI_i is equal to signature i (16 symbols, see S1.13).

Figure 19 illustrates the structure of the AICH.

- The AICH consists of access slots, each of length 1.25 ms.
- [The AICH access slots are transmitted time aligned with the PCCPCH frame boundary]
- The acquisition indicator is transmitted time aligned with the AICH access slots
- Up to 16 different acquisition indicators can be transmitted simultaneously within one access slot on one AICH.

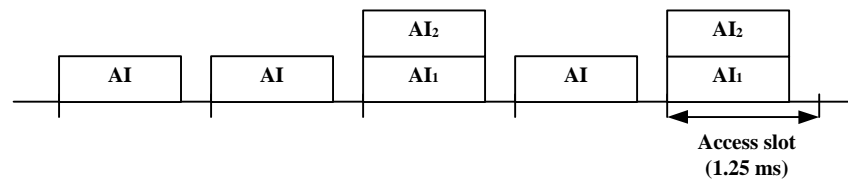

Figure 1949: AICH structure

3GPP

The AICH is transmitted on an ordinary downlink channel using a spreading factor of 256.

6 Mapping of transport channels to physical channels

Figure 20 summarises the mapping of transport channels to physical channels.

Transport Channels	Physical Channels
BCH	Primary Common Control Physical Channel (Primary CCPCH)
FACH	Secondary Common Control Physical Channel (Secondary CCPCH)
PCH	
RACH	Physical Random Access Channel (PRACH)
[FAUSCH]	
DCH	Dedicated Physical Data Channel (DPDCH) Dedicated Physical Control Channel (DPCCH) Synchronisation Channel (SCH)
DSCH	Physical Downlink Shared Channel (PDSCH)
DSCH control channel	Physical Shared Channel Control Channel (PSCCCH) Acquisition Indication Channel (AICH)

Figure 2020: Transport-channel to physical-channel mapping.

3GPP

The DCHs are coded and multiplexed as described in S1.12, and the resulting data stream is mapped sequentially (first-in-first-mapped) directly to the physical channel(s). The mapping of BCH and FACH is equally straightforward, where the data stream after coding and interleaving is mapped sequentially to the Primary and Secondary CCPCH respectively. Also for the RACH, the coded and interleaved bits are sequentially mapped to the physical channel, in this case the message part of the random access burst on the PRACH. The mapping of the PCH to the Secondary CCPCH is slightly more complicated to allow for an efficient sleep mode, and is described in the next section. The mapping of the DSCH to the PDSCH is done by mapping the data stream sequentially (first-in-first-mapped) directly to the physical channel.

6.1 Method for mapping of PCH to Secondary CCPCH

<Editors note: There is a basic fixed mapping of paging groups to paging blocks and a sliding paging mapping in order to improve the sleep mode.>

The method used to map the paging blocks to the Secondary CCPCH is shown in Figure 21. The PCH is divided into several blocks in one superframe. Paging groups are mapped to the paging blocks where layer 3 information to each group is transmitted.

The mapping between a paging group "i" and the paging block f(i), which is numbered between 1 and 288, is according

$f(i)=i$ (fixed mapping)

3GPP

$f(i)=((i+SUFN) \bmod N_{PB}) +1$ (sliding paging mapping to improve sleep mode)

where SUFN is the superframe number and $N_{PB}=288$ paging blocks per superframe. Thereby a paging group is mapped to the paging blocks

(i, i, ...) (fixed)

(i, i+1, i+2, ..., 288, 1, 2, ...) (sliding)

when the superframe number increases.

Each block on the PCH carries information amount worth of 4 slots, and consists of a total of 6 information parts: 2 Paging Indication (PI) parts - for indicating whether there are paging messages or not, and 4 Mobile User Identifier (MUI) parts - for indicating the identity of the UE and carrying the actual paging message.

In each block, PI parts are transmitted ahead of MUI parts.

In all groups, 6 information parts are allocated with a certain pattern in the range of 24 slots. By shifting each pattern by 4 slots, multiple 288 blocks of PCH can be allocated on one Secondary Common Control Physical Channel.

3GPP

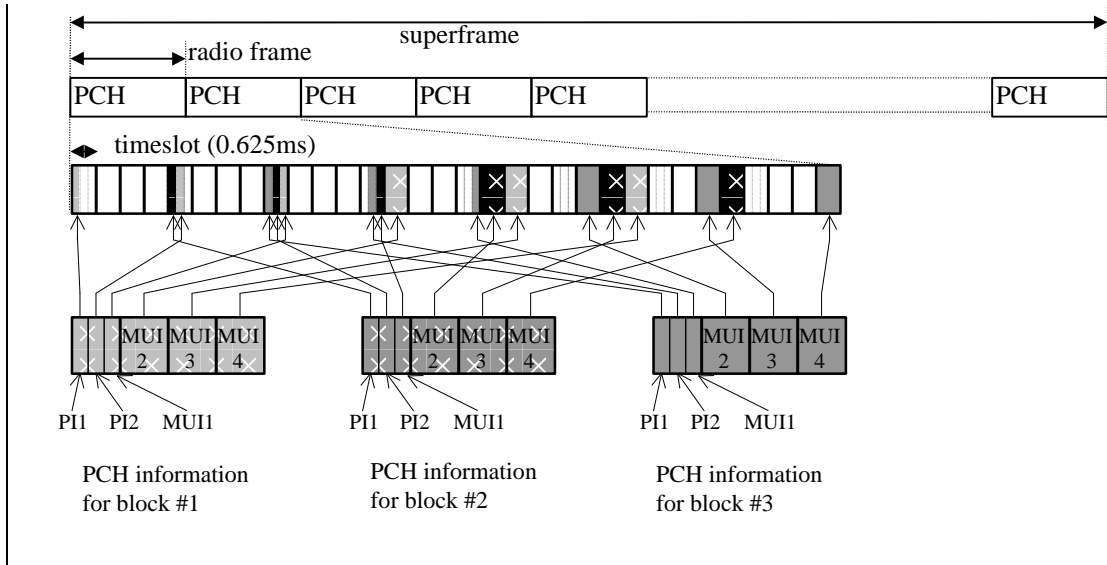

3GPP

Figure 2124: PCH mapping method.

6.2 Method for mapping of FACH to Secondary CCPCH

<Editors note: Removed because the mapping on transport channels is clearly a MAC issue and should be handled in WG2.>

<Editors note: The figure needs to be updated.>

Fig. XX 2 shows mapping method of FACH. There are two transport formats, FACH S and FACH L for FACH transmission. Which transport format to use is determined by MAC sub layer depending on the amount of information to be transmitted on FACH.

3GPP

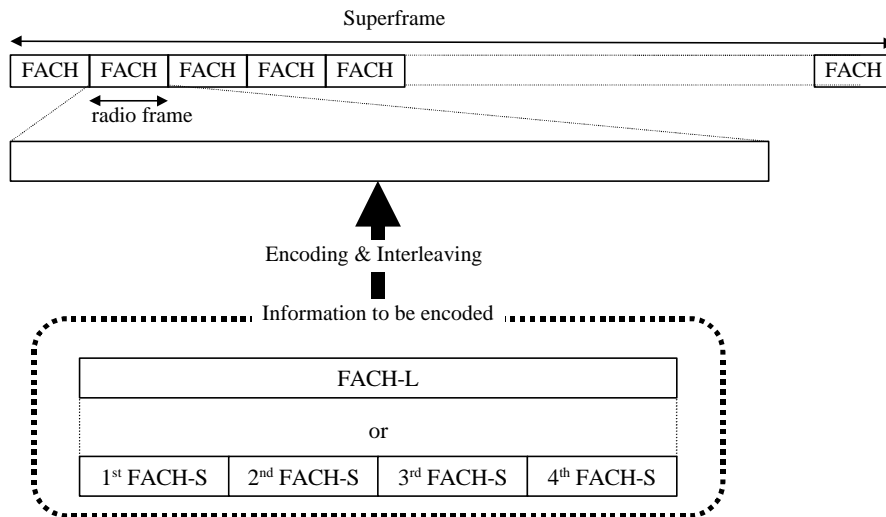

3GPP

Fig. XX-2 FACH Mapping Method

7 Timing relationship between physical channels

<Editors note: $M=36864=512*72$ needs to be confirmed.>

In general, a Node B covers N cells, where $N \ll 1$. Each Node B has a Reference System Frame Number (SFN), which counts from 0 to $M-1$ in Radio Frame (10 ms) intervals. M is a multiple of the superframe (72), and is TBD. The purpose of the Reference SFN is to make sure that the correct frames are combined at soft handover. Each cell has a Cell SFN, which is broadcast on the BCH.

Figure 22 shows the proposed physical channel timing parameters in a soft handover situation including two Node Bs, NB1 and NB2. The timing parameters in Figure 22 refer to frame-timing.

3GPP

3GPP

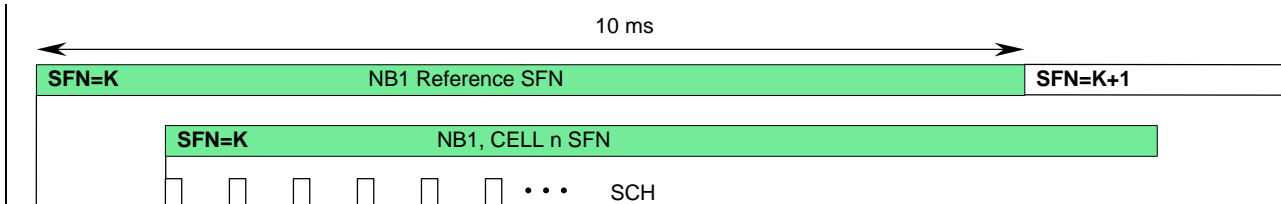

Figure 2222: Physical channel timing relations.

The parameters in Figure 2222 are explained below:

- T_p : Propagation delay between Node B and UE.
- T_{cell} : This timing offset is used for the frame timing of SCH, Primary CCPCH and the starting phase of all downlink scrambling codes in a cell. The resolution is TBD and depends on the maximum expected time-dispersion. The range is one slot. T_{cell} is also the reference frame timing for the PRACH. <Editors note: Descriptive text: The main purpose of T_{cell} is to avoid overlapping SCHs in different cells belonging to the same Node B. The resolution affects the number of possible cells in a Node B.>
- T_d : This timing offset is used for the frame timing of DPCHs and Secondary CCPCHs. It can be individually set up for each DPCH and Secondary CCPCH. The T_d values for the latter may be broadcast on the BCH, or known a-priori. The resolution is 256 chips in order to maintain downlink orthogonality and the range is TBD. <Editors note: Descriptive text: The purpose of T_d is:
 - In an originating/terminating cell, to distribute discontinuous transmission periods in time, and also to distribute Node B-RNC transmission traffic in time.
 - At soft handover, to synchronise downlink DPCHs to the same UE, in order to minimise the

3GPP

buffering requirements at the UE.>

- **T_o**: This constant timing offset is used to set up the transmission frame timing of an uplink DPCCH/DPDCH in the UE. The value is TBD. The starting phase of the uplink scrambling code is synchronised with the uplink DPCCH/DPDCH frame timing.
<Editors note: Descriptive text: The uplink DPCCH/DPDCH transmission frame timing should be set to T_o seconds after the frame timing of the earliest received path of the downlink DPCH. T_o should be chosen to minimise the closed loop PC delay in as large cell-radii as possible.>
- **T_m**: This value is measured by the UE and reported to the RNC prior to soft handover. The RNC can then notify this value to the target cell, which then knows how to set T_d to achieve proper reception and transmission frame timing of the dedicated physical channel.
<Editors note: Descriptive text: Note that since the UE reports the value T_m as the time-difference between the received Primary CCPCH frame-timing from the target cell and the earliest received existing DPCH path, the propagation delay to the target cell is already compensated for in the setting of T_d at the target cell. The DPCH signal from the target cell will reach the UE at the same time as the earliest received existing DPCH path. The only remaining error, besides frequency-drift and UE mobility related errors, is due to a (known) rounding error at the target cell in order to maintain downlink orthogonality.>

DSCH timing:

The relative timing between a DSCH and DCH is given as follows:
DSCH timing is identical to the cell primary CCPCH

3GPP

DCH timing is asynchronous with max 1 slot (0.625 ms) ahead or max 15 slots (15 times 0.625 ms) behind. This determines explicitly which frame on DSCH carries the user data based on the TFCI or higher layer signaling on DCH.

PRACH/RACH timing relation:

<Editors note: The PRACH/RACH timing issue is still under discussion.>

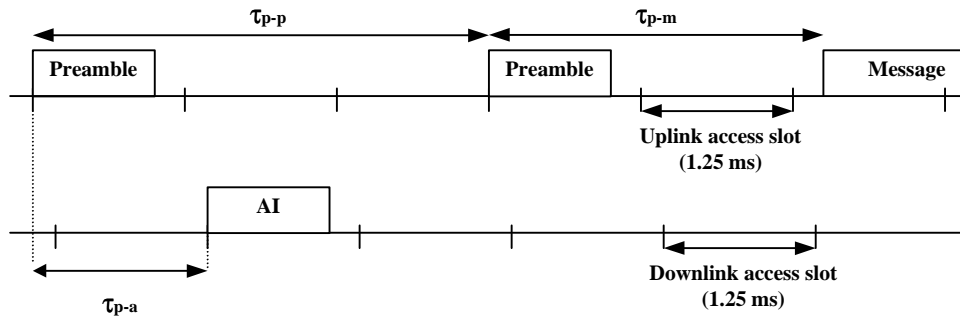

Figure 2323: Timing of PRACH and AICH transmission

3GPP

Figure 2323 illustrates the timing relation between PRACH and AICH.

- Both uplink and downlink access slots of length 1.25 ms are defined.
- For each downlink access slot there is a corresponding uplink access slot.
- The preambles are to be transmitted time aligned with the uplink access slots.
- The acquisition indicators (AI) are to be transmitted time aligned with the downlink access slots.
- [The downlink access slots are transmitted time aligned with the PCCPCH frame boundary.]
- An uplink access slot is transmitted a specified time τ_{p-a} before the corresponding downlink access slot.
- Subsequent preambles can be transmitted either two or three access slots after the latest transmitted preambles (τ_{p-p} is either 2 or 3 access slots).
- A message is transmitted a specified time τ_{p-m} after the latest transmitted preamble

3GPP

Appendix A: Power Control Timing

<Editors note: The Power control timing described in this appendix should be seen as an example on how the control bits have to be placed in order to permit a short TPC delay. It seems appropriate to move this part later.>

In order to maximize the BTS-MS distance within which one-slot control delay is achieved, the frame timing of a reverse link DPCH is delayed by $250\mu\text{s}$ from that of the corresponding forward link DPCH measured at the MS antenna.

Responding to a forward link TPC command, MS shall change its reverse link DPCH output power at the beginning of the first reverse link pilot field after the TPC command reception. Responding to a reverse link TPC command, BTS shall change its DPCH output power at the beginning of the first of later forward link pilot field after the TPC command reception. Note that the delay from the reverse link TPC command reception to the power change timing is not specified for BTS. MS shall decide and send TPC commands on the reverse link based on the forward link SIR measurement. The TPC command field on the reverse link starts, when measured at the MS antenna, $125\mu\text{s}$ after the end of forward link pilot field. BTS shall decide and send TPC commands based on the reverse link SIR measurement. However, the SIR measurement periods are not specified either for MS or BTS.



3GPP

Fig. A-1 illustrates an example of transmitter power control timings.

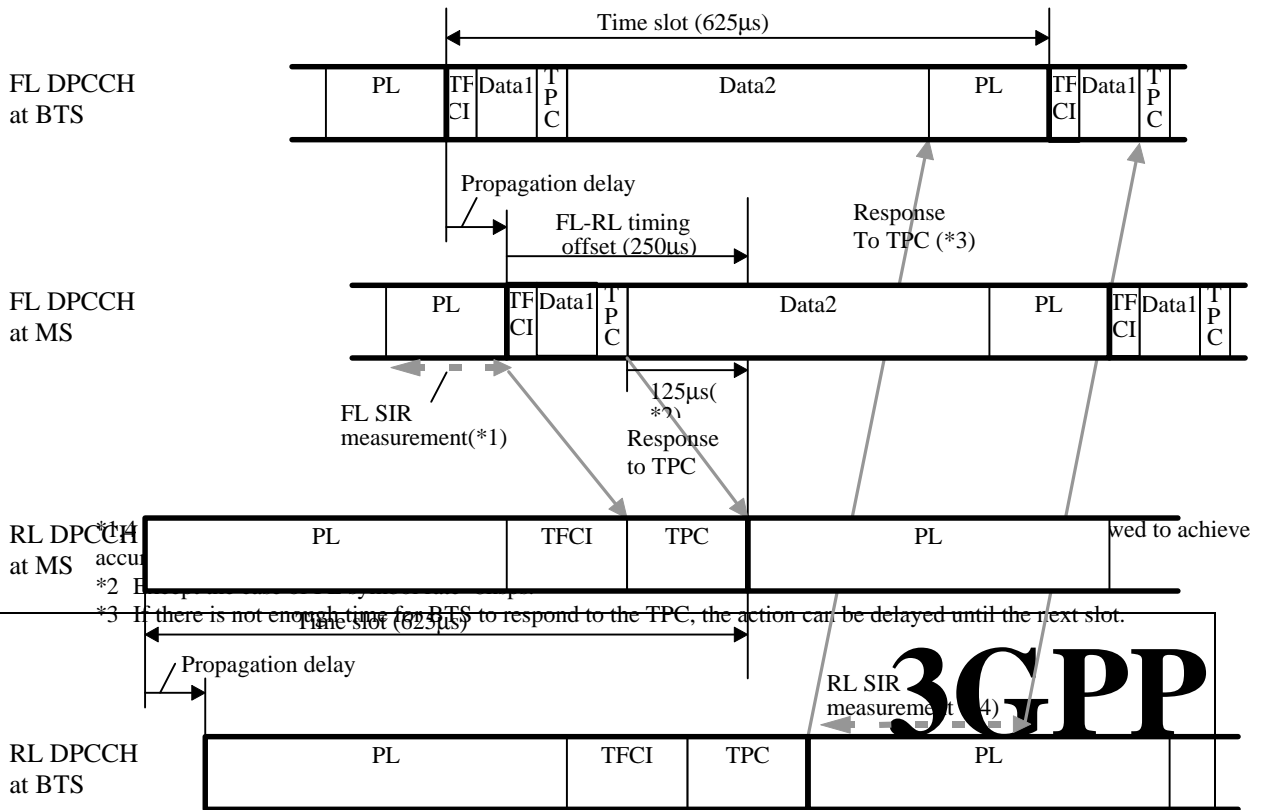

3GPP

Fig. A-1 Transmitter power control Timing

3GPP

History

Document history		
V0.0.0	1999-02-12	Created document from UMTS XX.03, V1.3.0
V0.0.1	1999-02-18	Small changes
V0.1.0	1999-02-26	Version approved by WG1#2. The changes agreed at the meeting to incorporate e.g. ad hoc conclusions not yet included
V1.0.0	1999-03-05	Version approved by RAN. Identical to V0.1.0
V1.0.1	1999-03-17	Included adhoc conclusions from WG1#2 and editorial changes.
V1.0.2	1999-03-23	Added adhoc conclusions from WG1#3
V1.0.3	1999-03-24	Added further text from Adhoc 6

3GPP

V1.1.0	1999-03-24	Version approved by WG1#3.
V1.1.1	1999-04-14	Updated RACH and Tx diversity description. Updated multicode figure. Added pilot table for PCCPCH. Removed FACH mapping section.

Editor for S1.11 is:

Andreas Wilde
Nippon Ericsson K.K.

Tel: +81 3 5216 9072

Fax: + 81 3 5216 9047

Email: **Error! Bookmark not defined.**andreas.wilde@ericsson.co.jp

This document is written in Microsoft Word 97.

3GPP