

3GPP TSG RAN Meeting #21
Frankfurt, Germany, 16 - 19 September 2003

RP-030542



INTERNATIONAL TELECOMMUNICATION UNION

**TELECOMMUNICATION
STANDARDIZATION SECTOR**

STUDY PERIOD 2001-2004

COM 11 – LS 10 – E

Original: English

Question(s): 7, 8, and 9/11

Geneva, 01 - 12 September 2003

LIAISON STATEMENT
(Ref. :TD 22R1 PLEN)

Source: Study Group 11

Title: Electronic Meeting on Signalling Requirements for IP-QoS

LIAISON STATEMENT

To: **Study Group 16, Q.F/16 (for action)**

copy (for information) to: Study Group 2, Q.2/2; Study Group 9, Q.13/9; Study Group 12, Q.13/12; Study Group 13, Q.16/13 & Q.6/13 & Q.7/13; ETSI (for 3GPP); TIA (for 3GPP2); ETSI (TIPHON & SPAN); Study Group SSG on IMT-2000 and beyond, Q.6/SSG & Q.7/SSG

Approval: Approved at ITU-T SG Meeting (12 September 2003)

For: **Action**

Deadline: **30 September 2003**

Contact: Greg Ratta, WP 2/11 Chairman
Lucent Technologies
101 Crawfords Corner Road
Holmdel, NJ 07733
USA

Tel: +1 732 530 8402
Fax: +1 732 949 1196
Email: greg-ratta@att.net

The participants of the joint Qs 7, 8, and 9/11 meeting on end-to-end IP-QoS accept the suggestion made in your last liaison to establish an electronic meeting to advance the state of signalling requirements in [TRQ.ipqos.sig.cs1](http://www.itu.int/itu-t/sg16/qf16/trq-ipqos.sig.cs1) and its harmonization with Annex N/H.323.

A new discussion area has been established via the TIES Discussion Forum Service entitled, "IP-QoS Signalling Requirements." This will serve as the "venue" to hold an interim electronic meeting, to be convened from October 27 through November 7, 2003. The proposed process for conducting this meeting is shown in Annex A to this liaison. All intended participants are encouraged to register with this new forum at <http://www.itu.int/forum/> by October 13, when the detail schedule for the electronic meeting is to be posted to the discussion forum. This registration is open to all ITU-T members.

Attention: Some or all of the material attached to this liaison statement may be subject to ITU copyright. In such a case this will be indicated in the individual document.
Such a copyright does not prevent the use of the material for its intended purpose, but it prevents the reproduction of all or part of it in a publication without the authorization of ITU.

Annex A
Procedures for Electronic Meeting on IP-QoS

1. Individuals register their intention to participate in the forum at <http://www.itu.int/forum/>, preferably by 13 October 2003.
2. Detailed schedule of discussion (organized by section of the baseline document) to be posted on the discussion forum by noon UTC on 13 October 2003. (Agenda bashing will extend until October 27 2003.)
3. The input document to the meeting is the final output from the September 2003 SG 11 meeting for TRQ.ipqos.sig.cs1 (TD 2/11-9r2).
4. Participants, including the Editor, will make proposals by E-mail for editorial changes to the document. These changes will typically be for specific sections, but may be global. Proposals for a given section will be accepted until noon UTC on the date shown in the schedule to be provided in step 2.
5. In the absence of a Q8/11 Rapporteur, the WP 2/11 Chairperson will record all proposed changes by section affected in a spreadsheet, along with useful control information. An updated version of this spreadsheet will be posted each business day during the meeting. Each specific proposal will be given a unique identifier for further reference.
6. Participants may respond to individual proposals, with counter-proposals or simply with an expression of agreement or disagreement. Responses must be clearly labelled as such, to distinguish them from original proposals. For convenience, responses should use the unique identifiers from the spreadsheet, but this is not essential so long as the proposal being addressed is unambiguously identified.
7. The schedule to be posted on the "discussion forum" will govern closure on proposals. Any proposal not drawing any response by noon UTC of the scheduled day of closure will be considered to have been accepted. Proposals to which responses have been made will be closed off when a consensus position is recognized.
8. A daily update of draft TRQ.ipqos.sig.cs1 will be posted at the same time as the spreadsheet. This will show the cumulative effect of changes accepted up to that date.
9. It is possible that proposals accepted for later sections would have implications for earlier ones. A second round of change proposals (expected to be few in number) will be accepted and reviewed when the first round is complete. The second round proposals will be considered only if they are a clear consequence of decisions made in sections other than the one for which each proposal is made.
10. A report of this activity will be made to the next SG 11 meeting for its approval and acceptance.

Attention: Some or all of the material attached to this liaison statement may be subject to ITU copyright. In such a case this will be indicated in the individual document.
Such a copyright does not prevent the use of the material for its intended purpose, but it prevents the reproduction of all or part of it in a publication without the authorization of ITU.

Question(s): 7, 8, 9/11

Geneva, 01 - 12 September 2003

TEMPORARY DOCUMENT

Source: Editor pro tem

Title: Draft Technical Report TRQ.IPQoS.Sig.CS1 – Signalling Requirements for IP-QoS

Abstract

~~This is an output document from the meetings related to IP-QoS signaling requirements (representing Qs7, 8 & 9/11) that were held in April 2003. It is identical to the document, “TD FRA 106” that was approved by the participants of that meeting.~~

This TD contains the draft of TRQ.IPQoS.Sig.CS1 that represents the agreed output document from the ~~April-September~~ 2003 ITU SG 11 ~~Interim Meeting on IP-QoS~~.

[Editor’s Note: The editing team during the November 2002 ~~ITU~~ITU-T SG 11 meeting determined that the text in this TRQ is based on Y.1541, Y.qosar, Y.1540, Y.1221 and E.QSC except clauses 5.1.5, 5.2.3, and 5.10. Requirements to support emergency services need to be verified with F.706.]

Contact: Greg Ratta
Lucent Technologies
U.S.A.

Tel: +1 732 332 5174
Fax: +1 732 949 1196
Email: greg-ratta@att.net

Attention: This is not a publication made available to the public, but **an internal ITU-T Document** intended only for use by the Member States of the ITU, by ITU-T Sector Members and Associates, and their respective staff and collaborators in their ITU related work. It shall not be made available to, and used by, any other persons or entities without the prior written consent of the ITU-T.



INTERNATIONAL TELECOMMUNICATION UNION

ITU-T Draft TRQ.IPQoS.SIG.CS1

TELECOMMUNICATION (date)
STANDARDIZATION SECTOR
OF ITU

Series Q: Switching and Signalling

Draft Technical Report TRQ.

SIGNALLING REQUIREMENTS FOR IP-QoS

Supplement to
ITU-T Q-Series Recommendations
(previously CCITT Q-Series Recommendation)

CONTENTS

1	Scope	5
1.1	Background.....	5
1.2	Functional Reference Model.....	7
2	References.....	7
3	Definitions	8
4	Abbreviations.....	9
5	Requirements	10
5.1	User-Network Signalling.....	10
5.1.1	Attributes of a User QoS Request.....	10
5.1.2	Omitting Attributes of a User QoS Request.....	11
5.1.3	Form of a Verifiable User QoS Request	11
5.1.4	Special Case of User QoS Request to support Voiceband Channels.....	11
5.1.5	Flow Control for User QoS Requests and Re-requests.....	11
5.1.6	Network Response to User QoS Requests.....	11
5.1.7	User Answer to Network QoS Response	12
5.2	Network - Network QoS Signalling	12
5.2.1	Attributes of a Network QoS Request	12
5.2.2	Omitting Attributes of a Network QoS Request	13
5.2.3	Performance Requirements for QoS Requests and Re-requests.....	13
5.2.4	Response to a Network QoS Request	14
5.2.5	Accumulating Performance for Additional Requests.....	14
5.3	QoS Release	14
5.4	Performance.....	14
5.5	Symmetry of information transfer capability.....	15
5.6	Contention resolution	15
5.7	Error reporting.....	15
5.8	Unrecoverable failures.....	15
5.9	Forward and backward compatibility.....	15
5.10	Parameters and values for Transport connections	15
5.11	User-Initiated QoS Resource Modification.....	15
5.12	Emergency Service.....	16
5.13	Reliability/Priority Attributes	16
6	Architecture of IP Signalling.....	16
7	IP Signalling Flows.....	17
7.1	Successful Transport Connection Establishment Information Flows	17
I.1	User-Network Signalling in support of Network QoS Class	19

I.2	Network-Network Signalling.....	20
I.3	Future Development of Classes to support Reliability and Priority Attributes.....	21

SUMMARY

This Supplement to the Q series of ITU-T Recommendations contains a Technical Report that specifies the general aspects of IP-QoS signalling requirements for the development of new or enhanced specifications.

This Technical Report identifies the capabilities for IP-QoS Signalling. In addition, it describes the essential features and models for the development of functional entity actions in support of IP-QoS Signalling.

Draft Technical Report TRQ.

DRAFT TECHNICAL REPORT TRQ. – SIGNALLING REQUIREMENTS FOR IP-QoS

1 Scope

This TRQ provides the requirements for signalling information regarding IP-based quality-of-service (QoS) at the interface between the user and the network (UNI) and across interfaces between different networks (NNI). These requirements and the signalling information elements identified will enable the development of a signalling protocol(s) capable of the request, negotiation and ultimately delivery of known IP QoS classes from UNI to UNI, spanning NNIs as required.

The signalling requirements also address signal information related to traffic priority and admission control, as these are also central to truly comprehensive QoS.

1.1 Background

Although QoS is by definition (in multiple ISO, ITU-T and other standards) based on the experience of the service user, the mechanisms for achieving differentiated packet treatment are themselves taken all too often as being the same as "real" end-to-end QoS.

To meet specific network performance requirements such as those specified for the QoS classes of Y.1541, a network provider needs to implement services such as those specified in Y.1221.

To implement the transfer capabilities defined in Y.1221, a network needs to provide specific user plane functionality at UNI, NNI, and INI interfaces. A network may be provisioned to meet the performance requirements of Y.1541 either statically or dynamically on a per flow basis using a protocol that meets the requirements specified in this document.

Static network provisioning is typically performed by a network engineering team using a network management system. Static provisioning typically takes into account both overall network performance requirements and performance requirements for individual customers based on traffic contracts between the customer and the network provider.

Dynamic network provisioning at a UNI and/or NNI node allows the ability to dynamically request a traffic contract for an IP flow (as defined in Y.1221) from a specific source node to one or more destination nodes. In response to the request, the network determines if resources are available to satisfy the request and provision the network.

True QoS goes beyond just the delay and loss that can occur in the transport of IP packets. The requirements include:

- bandwidth/capacity needed by the application, and
- the priority with which such bandwidth will be maintained during congestion and with which it will be restored after various failure events.

As these aspects of QoS can be related to routing, they go beyond the resource management of the packet transport. To make the protocol envisioned by this TRQ comprehensive, requirements on priority and admission controls are also considered. [Figure 1 shows the various possible control and in-band \(i.e. indications in packet headers\) mechanisms.](#)

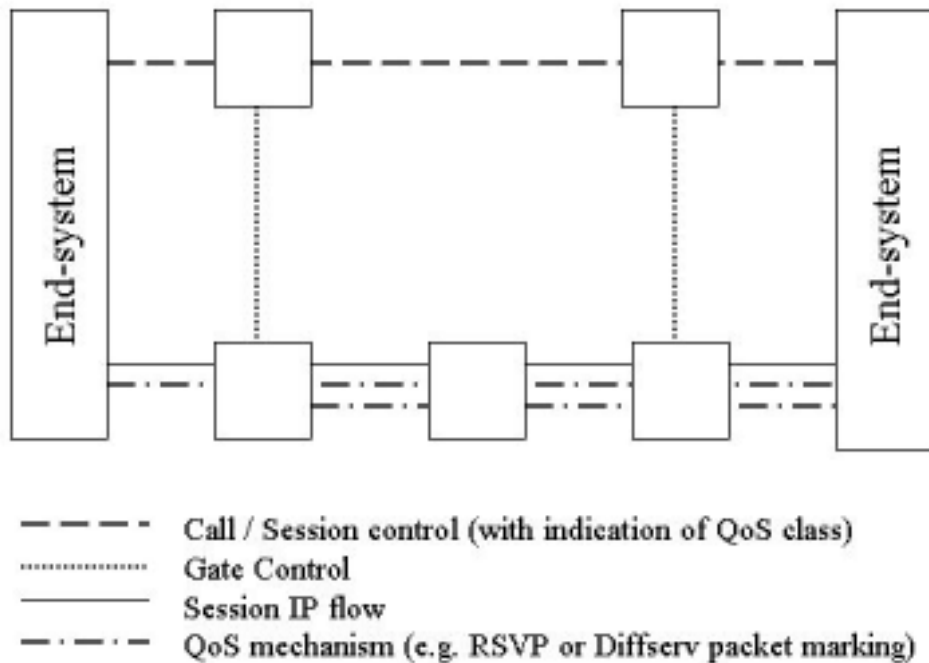

Note – All QoS mechanisms may not be necessarily end-to-end.

Figure 1 – [Relationship between the different control and user plane mechanisms for providing different levels of QoS](#)

[The call/session control signalling includes an indication of the QoS requirements for each session. The QoS requirements are realised using various mechanisms, e.g. packet fragmentation, over-provisioning, resource reservation \(RSVP\) or Diffserv. Different QoS mechanisms may be used on different sections of a session packet-forwarding path. There may be communication between call/session control nodes and packet-forwarding devices using a “gate” control protocol to control the QoS mechanism.](#)

1.2 Functional Reference Model

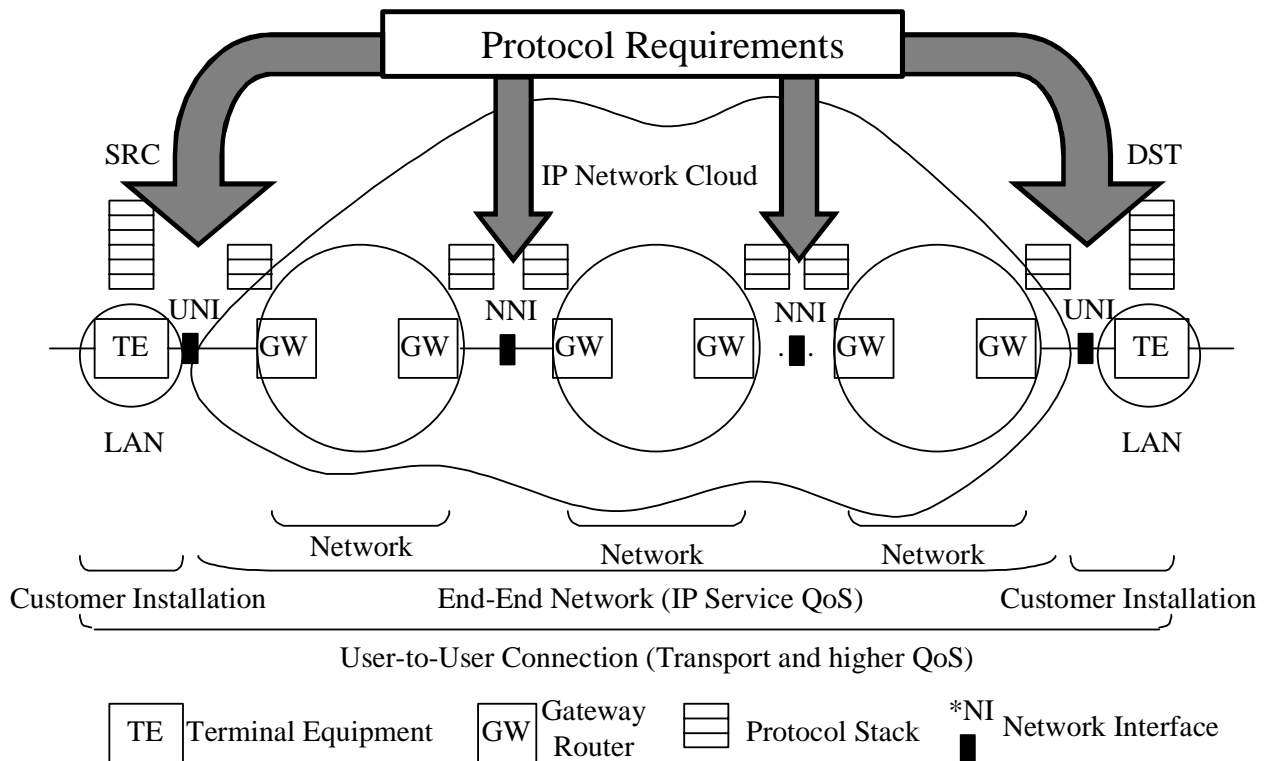

Figure 21 - The Scope of QoS Signalling Requirements

QoS signalling requirements are expressed in terms of attributes related to User-Network Signalling as well as Network-Network signalling. Major attributes include the following:

- the network QoS Class (i.e., Y.1541/Table 1);
- the network Capacity required, at both the application and network (i.e., Y.1221) levels;
- the Reliability/Priority with which the service is to be sustained; and
- other elements of QoS.

[Editors Note: the complete set of classes for Reliability/Priority is yet to be defined.]

This document recognises that an automated system for obtaining User-to-User QoS on IP Networks, and on combinations of various network technologies, will require standard signalling protocols for communicating the requirements among the major entities. For the purposes of this document, these entities are defined as:

1. Users and their end Terminal Equipment (TE); and
2. Network Service Providers/Operators and their equipment, especially equipment implementing the inter-working and signalling function between networks, and between users and networks.

2 References

This Technical Report incorporates, by dated or undated reference, provision for referencing material from other publications. These references are cited at the appropriate places in the text and the publications are listed hereafter. For dated references, subsequent amendments to or revisions of any

of these publications apply to this document only when incorporated into by amendment or revision. For undated references, the latest edition of the publication applies.

[Editors Note: The References will be edited before issue.]

- [1] ITU-T Technical Report TRQ.2400 – Transport Control Signalling Requirements – Signalling Requirements for AAL Type 2 Link Control Capability Set 1.
- [2] ITU-T Technical Report TRQ.2401 – Transport Control Signalling Requirements – Signalling Requirements for AAL Type 2 Link Control Capability Set 2.
- [3] ITU-T Recommendation I.255.4 – Integrated Services Digital Network (ISDN), General Structure and Service Capabilities, Priority Service.
- [4] IETF RFC 791, "Internet Protocol", J. Postel, September 1981
- [5] IETF RFC 2460, "Internet Protocol, Version 6 (IPv6) Specification", S. Deering and R. Hinden, December 1998
- [6] ITU-T Recommendation X.213 – Data Networks and Open System Communications - Open Systems Interconnection – Service Definitions
- [7] ITU-T Recommendation E.164 – The International Public Telecommunication Numbering Plan
- [8] IETF RFC 2474 (Definition of the Differentiated Services Field (DS Field) in the IPv4 and IPv6 Headers)
- [9] IETF RFC 2597 (Assured Forwarding PHB Group)
- [10] IETF RFC 2598 (An Expedited Forwarding PHB)
- [11] IETF RFC 768, "User Datagram Protocol", J. Postel, August 1980
- [12] IETF RFC 1889 "RTP: A Transport Protocol for Real-Time Applications", H. Schulzrinne et al., January 1996
- [13] IETF RFC2960, "Stream Control Transmission Protocol", October 2000
- [14] IETF RFC 3332, "SS7 MTP3-User Adaptation Layer (M3UA)", September 2002.
- [15] ITU-T Recommendation Q.1902.4 – Bearer independent call control protocol, basic call procedures
- [16] ITU-T Recommendation Q.2630.2 – AAL type 2 signalling protocol - Capability Set 2
- [17] ITU-T Recommendation Y.1540 – Internet protocol data communication service - IP packet transfer and availability performance parameters
- [18] ITU-T Recommendation Y.1541 – Network performance objectives for IP-Based services
- [19] Y.qosar
- [20] Y.1221
- [21] E.QSC

3 Definitions

[Editors Note: The definitions will be edited before issue.]

Transport Connection	A bi-directional User Plane association between two IP Service Endpoints at the Transport Layer
----------------------	---

IP Transport Protocol	A transport protocol operating over IP such as UDP, TCP
IP Transport Packet Size	Length of the payload of a IP Transport Protocol contained in a IP packet
IP Service Endpoint	A functional entity which includes one type of IP Signalling Endpoint and the IP Served User
User	A user of the IP Signalling Protocol
IP Signalling Endpoint	The termination point of an IP signalling path
IP Signalling Protocol	Control plane functions for establishing, modifying and releasing Transport Connections and the associated maintenance functions.
Network Entity	The network element responsible for terminating the IP Signalling Protocol.
Transport Sink Address	Contains the IP address and Port Number, where the sender expects to receive U-plane information.
Terminal Equipment (TE)	A specific implementation of an IP Signalling Endpoint.
QoS Class	QoS Class of the received and transmitted U-plane information
Entrance Node	Tbd
Exit Node	Tbd

4 Abbreviations

[Editors Note: The abbreviations will be edited before issue.]

DSCP	Differentiated Services Code Point
IP	Internet Protocol
M3UA	SS7 MTP3-User Adaptation Layer
NNI	Network Node Interface
QoS	Quality of Service
RTP	A Transport Protocol for Real-Time Applications
SS7 MTP-3	CCITT Signalling System No.7, Message Transfer Part, Layer 3
UDP	User Datagram Protocol

5 Requirements

Authentication of User and Network Peers is a prerequisite for QoS signalling. Authentication may be accomplished by static extension of the zone of trust, or through an Authentication Protocol, which is beyond the scope of these requirements.

5.1 User-Network Signalling

The following requirements apply to QoS Signalling between Users (or their terminal equipment) and the responsible network entity.

5.1.1 Attributes of a User QoS Request

[Editor's Note: Contributions are sought to identify the specific signalling requirements for the UNI and NNI protocols.]

It shall be possible to derive the following service level parameters as part of the process of requesting service:

1. QoS class from Y.1541¹
2. peak rate (Rp)
3. peak bucket size (Bp)
4. sustainable rate (Rs)
5. sustainable bucket size (Bs)
6. maximum allowed packet size (M)
7. IP DS field as specified in RFC 2474[8]

It should be possible to derive the following service level parameters as part of the process of requesting service:

1. the Reliability/Priority with which the service is to be sustained, and
2. other elements of QoS.

Note that the complete set of classes for Reliability/Priority is to be defined.

Users must be able to initiate requests for service quality with the following main attributes:

- the network QoS Class (e.g., Y.1541/Table 1);
- the network Capacity required, at both the application and network (e.g., Y.1221) levels;
- the Reliability/Priority with which the service is to be sustained; and
- other elements of QoS.

Note that the complete set of classes for Reliability/Priority is to be defined.

Optional attributes include the user Application type and quality from among several quality categories, when such categories are available. The type of application may be completely specified from the chosen quality category.

Each of these attributes shall be signalled in independent fields in signalling messages.

¹ The values of IP Loss Ratio, IP Transfer Delay, and IP Delay Variation as specified in Y.1221 may be derived by specifying the QoS class from Y.1541 as a signaling parameter.

Terminal Equipment (TE) should compose the detailed request on the user's behalf, possibly based on configurations set by the user or equipment installer. Many TE have the flexibility to match the user's request for application quality with network QoS classes by selecting parameters such as source coder type and packet size.

5.1.2 Omitting Attributes of a User QoS Request

Network QoS Class, Capacity, and Reliability/Priority are required attributes; others are optional. The Network Provider may assign default values for omitted attributes.

For example, Speech quality categories have been defined in ITU-T Rec. G.109, but there is no comparable standard range of quality categories for Web browsing, financial transactions, or many other applications of networks (each is associated with a limited quality range in new ITU-T Rec. G.1010). ITU-T Rec. P.911 tabulates quality categories for Multimedia Communication (also known as video/audio/data conferencing) and Television applications. Users may simply wish to make requests for capacity, network QoS class, and reliability.

5.1.3 Form of a Verifiable User QoS Request

The user/TE must make its QoS request in terms the network understands, especially the parameters for Network QoS. The Network QoS Classes and Network Capacity specifications in the signalling protocol must contain values that are verifiable by users (the classes in Y.1541 meet that requirement). TE may conduct measurements to ensure that the committed performance and capacity levels are achieved by the network(s).

5.1.4 Special Case of User QoS Request to support Voiceband Channels

[Editor's Note: With further clarification of the scope of this document, modification of this subclause may be required.]

When the user/TE request is for a voiceband channel (to support speech or voice band modems), the QoS request (or other associated message) should contain the preferred voiceband codec and packet size. Other optional parameters may be included to indicate, for example, the use of silence suppression, the need for network echo cancellation, and alternate codecs/packet sizes.

Many of the capacity attributes will be determined by this codec choice. Also, the network operation benefits from knowledge of the codec when the need for voice transcoding can be identified (and possibly avoided). However, much of the negotiation of application parameters takes place beyond the network's purview.

5.1.5 Flow Control for User QoS Requests and Re-requests

[Editors Note: Input from D.318 only. Contributions are requested to clarify the underlying requirement and be consistent with what an industry standard can specify.]

The TE must wait X seconds before re-submitting a request, and may have a maximum of Y simultaneous requests outstanding. Time-outs for re-submission will increase exponentially. The protocol must be "congestion-aware," using failed requests as implicit indications of congestion or using explicit notification of congestion, if available.

5.1.6 Network Response to User QoS Requests

Network Service providers should be able to communicate the following messages and attributes (in the case of user-network interaction):

1. An Identification Code for the request exchange, to be used in this response and all messages that follow (such as User ACK, or Release, and also in Network-Network messages). When used together with other information, such as Src address, each request can be uniquely referenced.
2. The simple acknowledgement and acceptance of user/TE requests.
3. The performance level expected. The ability to achieve a performance level that is better than an aspect of the QoS Class response, if the network operator desires. This indication may be made for a single performance parameter, or for a combination of parameters.
4. The ability to reject a request and, at the same time, to offer a modified service level that can be met. The response may modify the request and may include commitments to an alternate QoS Class, a lower capacity, and other indications such as those in item 3.

The processing of each request and determination of acceptance require considerable work on behalf of the network provider/operator. However, these are simple tasks from the signalling point of view, and the rejections with alternatives are illustrated in Appendix I. Networks may wish to indicate a maximum time interval for which the response is valid.

5.1.7 User Answer to Network QoS Response

The final decision to accept or reject an offered service is left to the user/TE. This completes a Request-Offer-Answer exchange.

5.2 Network - Network QoS Signalling

This section treats the case where multiple networks co-operate to realise the end-to-end connectivity desired. Beyond the applications considerations mentioned above, network providers/operators primarily deal with Network QoS Classes, Network Capacity, and Reliability. Network-network signalling is the principle way for networks to determine multi-network compliance with QoS classes, since fixed performance allocations are not currently possible on IP Networks.

Network - Network signalling shall support the determination of the QoS Class offered to the user/TE, by communicating both the Network QoS Class requested, and the extent to which each specified parameter is already consumed. This implies that each network knows the performance from the entrance node to the (most likely) exit node(s) for the network that has the best opportunity to complete the end-end path. Policies may also determine the next network chosen. The best-next network receives the network-network signalling request.

Networks shall determine if the desired capacity and reliability are available to support the specified Network QoS Class from entrance to exit node(s).

5.2.1 Attributes of a Network QoS Request

The attributes of the network's request are:

- the network QoS Class (e.g., Y.1541/Table 1), along with the consumption of individual objectives that are specified by the class;
- the network Capacity required, at both the application and network (e.g., Y.1221) levels;

- the interconnecting point(s), where user/TE traffic will leave the requesting network and enter the next network;
- the Reliability/Priority with which the service is to be sustained; and
- other elements of QoS.

Note that the complete set of classes for Reliability/Priority is yet to be defined.

Optional attributes include the user Application type and the quality category, when such categories are available and meaningful.

Each of these attributes shall be signalled in independent fields in signalling messages.

5.2.2 Omitting Attributes of a Network QoS Request

Network QoS Class, Capacity, and Reliability/Priority are required attributes; others are optional.

5.2.3 Performance Requirements for QoS Requests and Re-requests

[Editor's Note: With further clarification of the scope of this document, modification of this subclause may be required.]

An important aspect of the requirements for a signalling protocol is the performance requirement associated with that protocol. The most important areas where signalling performance requirements need to be established is the average / maximum latency for the establishment of service and the average / maximum latency for the re-establishment of service in the event of a network failure. The latency requirements described above for the signalling protocol depend on the performance characteristics of the underlying transport network. Because of this, performance requirements for the transport network must be specified along with the latency requirements for the signalling protocol. The combination of these factors leads to the following formal performance requirements for the signalling protocol.

1. Networks designed to meet the signalling protocol requirements specified in this section should be capable of supporting the network performance objectives of QoS class 2 in Y.1541.
2. Signalling protocol endpoints that generate signalling messages should be capable of setting the IP DS field of those messages to a value that is associated with the statistical bandwidth transfer capability defined in Y.1221.
3. The average delay from the time of a UNI or NNI request for service to the acceptance or rejection of this service request by the network should be <800 msec².
4. The maximum delay from the time of a UNI or NNI request for service to the acceptance or rejection of this service request by the network should be <1500 msec².
5. The average delay from the time of a network failure to the time of re-establishment of service at any UNI or NNI interface should be <800 msec². (This does not address restoration of failed links.).
6. The maximum delay from the time of a network failure to the time of re-establishment of service at any UNI or NNI interface should be <1500 msec²

² This numeric value needs to be substantiated using references to ITU or IETF performance standards in the area of signalling.

5.2.4 Response to a Network QoS Request

Network providers shall be able to respond with the following messages and attributes (in the case of network-network interaction):

1. The ability to correlate all responses and subsequent requests to the original request is required. An Identification Code is one example.
2. The simple acknowledgement and acceptance of requests.
3. The ability to indicate a performance level that exceeds an aspect of the request/response is required, but the indication to other entities is a network option.
4. The terminating network supporting the destination UNI shall offer a modified service level if the original service level cannot be met. The modified service may include commitment to an alternate QoS Class, a lower capacity, etc.

It is possible that a chain of network-network QoS requests will encounter a network that does not support the QoS signalling protocol or QoS Classes in general. If this network is an essential section of the end-to-end path, then several results are possible. One is to reject the request, but at the same time offer an Unspecified Class (e.g., Class 5 of Y.1541), possibly with some additional parameter value indications.

When making entrance-to-exit performance commitments, only one of the interconnecting links will be included for all networks, except the (first/last - this is TBD).

5.2.5 Accumulating Performance for Additional Requests

Signalling must communicate the consumption of the network (source-UNI to destination-UNI) QoS objectives. The fields used in signalling may take two forms, listed below, but the signalling messages must use one form consistently. See Appendix I for examples based on the Y.1541 Network QoS classes.

1. The forwarded request contains only the achieved values and the requested/achieved Class number require signalling fields.
2. Each network communicates its contribution to the achieved performance level. A complete tabulation of the accumulated performance would allow corrective network actions if the Requested Class were not achieved.

5.3 QoS Release

Users and Networks shall be able to signal when a previously requested network resource is no longer needed.

5.4 Performance

For reasons of signalling performance, the following areas should be addressed:

- a) the number of messages required to establish, maintain and clear QoS requests should be kept to a minimum; and
- b) the format of the IP Signalling Protocol information should be chosen to minimize message-processing delays at the endpoints.

5.5 Symmetry of information transfer capability

The QoS Signalling protocol shall support symmetric QoS Requests.

Asymmetric QoS Requests are optional. That is, the end-to-end requests may be bi-directional where the information transfer capability in each direction might be different.

5.6 Contention resolution

The QoS Signalling protocol shall be able to resolve all contentions with respect to resource allocation and collisions when establishing IP connections.

5.7 Error reporting

The QoS Signalling Protocol shall include mechanisms for detecting and reporting signalling procedural errors or other failures detected by the TE/Network to IP management. Service failures may also be reported to the User.

5.8 Unrecoverable failures

The TE and Network Entities shall include mechanisms for returning the QoS protocol instance to a stable state after detection of unrecoverable failures.

5.9 Forward and backward compatibility

The QoS Signalling Protocol shall include a forward compatibility mechanism and backward compatibility rules.

5.10 Parameters and values for Transport connections

[Editors Note: Clarification is sought for the definition of source and destination addresses in the following objective.]

The signaling protocol at UNI interfaces should be capable of specifying the following additional parameters as part of the process of requesting service:

1. IP header fields: source + destination address (RFC 791, RFC 2460);
2. IP DS field (RFC 2474, RFC 3260); and
3. Source + destination port as specified in RFC 768 and RFC 793.

5.11 User-Initiated QoS Resource Modification

Either User may be able to modify the resources associated with an active Transport connection, represented by the information contained in the Transport Connection messages.

Note: This modification of Transport connection resources only involves CAC (Connection Admission Control).

Collision of connection resource modification requests shall be avoided by the Served User.

Modification shall be performed with no loss of IP transport contents.

The use of the preferred Transport Connection messages is to avoid the need for subsequent modification of the connection resources immediately after the establishment.

User/TE (IP Endpoints) should determine, through the use of end-end application level capability signalling, the ability and support to use resources beyond those currently in use. The support / lack of support of the capability to modify Transport Connection messages, for a Transport connection must be indicated by the originating IP Endpoint. The terminating IP Endpoint must indicate the support / lack of support of the modification capability of the Transport Connection messages. Only when both Endpoints indicate modification support can modification be attempted.

This capability uses the following objects:

- Transport Connection message Modification Support Request,
- Transport Connection message Modification Support Response.

5.12 Emergency Service

[Editors Note: Verify with F.706]

Emergency Services are required to be supported in a future version. The protocol will identify reserved objects, bits, etc. This topic is treated in general under Reliability and Priority Attributes.

5.13 Reliability/Priority Attributes

Reliability/Priority attributes are the same for User-Network and Network-Network signalling requirements. Reliability for a service can be expressed in the form of a priority level with which that service requires a particular type of network function (e.g., Connection Admission Control Priority). Hence, reliability can be requested in the form of a Priority Class for that specific network function. Two types of network functions apply for Reliability/Priority classes: Connection Admission Control and Network Restoration. As an example, emergency services can signal for the highest available connection admission control priority during emergency conditions.

No formal standards exist with respect to the qualitative (e.g., number of priority classes) or quantitative (e.g., time-to-restore) aspects of reliability. From the viewpoint of signalling, there should be a limited number of Priority Classes for all network functions in order to ensure scalability (e.g., 4 classes). The signalling protocol needs to be able to provide the capability to effectively convey these priority requests once priority level attributes are established in standards forums. See Appendix I for more information on these attributes.

6 Architecture of IP Signalling

The figure below illustrates the architecture.

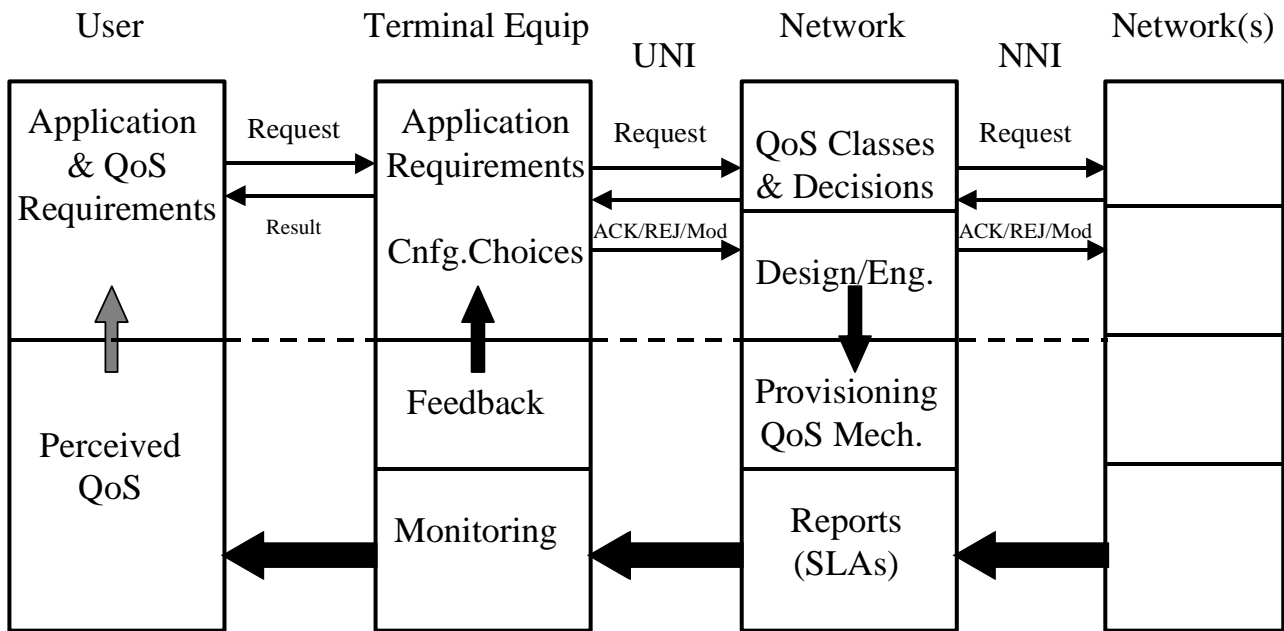

Figure 32 – Architecture of IP Signalling

The top half of the figure illustrates the various entities that participate in the QoS signalling, while the lower half broadly indicates the entities that implement and attempt to achieve the agreed QoS Levels.

UNI Signalling takes place on the same path as the application packet flow. This is referred to as On-Path. NNI Signalling may be On-Path, or may take place on a dedicated path. The implementation of signal processing within a Network depends on the model chosen, whether it is hop-by-hop (distributed processing On-Path), centralized, or some combination of these two.

7 IP Signalling Flows

[Editors Note: Needs to be updated to reflect UNI-NNI-UNI flow.]

The following diagrams illustrate the establishment (successful and unsuccessful), connection resource modification (successful and unsuccessful) and release of an IP connection.

7.1 Successful Transport Connection Establishment Information Flows

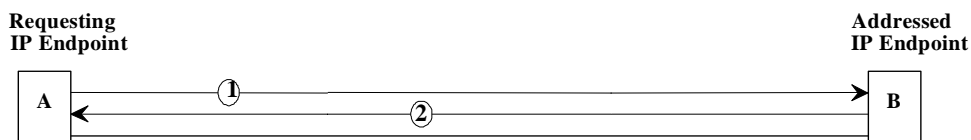

Figure 43 - Successful Transport Connection Establishment Information Flows

The flows illustrated in Figure 4/TRQ.IPL are as follows:

1	IP Setup-Request.ready	Requesting End Point to Addressed End Point
	<u>User information</u> IP served user generated reference Served user transport information	<u>Connection information</u> Signalling Transport Connection Characteristics Signalling Transport Preferred Connection Characteristics (optional) Signalling Transport Connection Characteristics Modification Support Request QoS Class IP Transport Type IP Sink Address of A Called End Point Address Transport Priority Indicator

Initiation of information flow: The Requesting Endpoint starts to establish an IP network connection.

Processing upon receipt: The Addressed Endpoint assures that enough resources in the endpoint remain for the new IP network connection. It then issues Information Flow 2 to confirm the establishment. Finally, the IP Served User is informed about the establishment of the new IP network connection.

2	IP Setup-Request.commit	Addressed End Point to Requesting End Point
	<u>User information</u> (none)	<u>Connection information</u> Signalling Transport Connection Characteristics Modification Support Response IP Sink Address of A IP Sink Address of B

Processing upon receipt: The Requesting Endpoint informs the IP Served User about the completion of the requested IP network connection establishment.

APPENDIX I

Examples to support QoS Signalling Requirements based on Y.1541 Network QoS Classes, and additional information on Reliability/Priority

I.1 User-Network Signalling in support of Network QoS Class

An example of Network Response 3 (section 5.1.6) (QoS Class Acceptance and parameter level indication) is a case where the network provider commits to the requested Class and indicates the achieved performance for Delay and Delay Variation supporting the Class 0 objectives. The values indicated are simply estimates of performance, and the only binding commitment is to the QoS Class. In the following tables, acceptance of the QoS Class indicates commitment to its objectives.

Table I-1 Example of QoS Class acceptance with specified parameter indications

Field Name	Value	Mandatory Field?
QoS Class Requested	Class 0	Yes
QoS Class Response	Accept	Yes
Mean Transfer Delay (IPTD)	80 ms	No
99.9% - min Delay Var. (IPDV)	20 ms	No
Loss (IPLR)		No
Errored Packets (IPER)		No

An example of Network Response 4 (section 5.1.6) (QoS Class rejection and alternate Class commitment and indications) is a case where the network provider rejects the requested Class and offers another Class with a specified parameter indication for Delay.

Table I-2 Example of QoS Class rejection with alternative offer and indications

Field Name	Value	Mandatory Field?
QoS Class Requested	Class 0	Yes
QoS Class Response	Reject	Yes
QoS Class Offered	Class 1	No
Mean Transfer Delay (IPTD)	180 ms	No
99.9% - min Delay Var. (IPDV)		No
Loss (IPLR)		No
Errored Packets (IPER)		No

I.2 Network-Network Signalling

Signalling must communicate the consumption of the network (source-UNI to destination-UNI) QoS objectives. The fields used in signalling may take several forms:

Table I-3 Example of accumulating and signalling current performance

	Requested	Currently Achieved
QoS Class	Class 0	Class 0
Mean Transfer Delay (IPTD)	100 ms	20 ms
99.9% - min Delay Var. (IPDV)	50 ms	10 ms
Loss (IPLR)	10^{-3}	$<10^{-3}$
Errored Packets (IPER)	10^{-4}	$<10^{-4}$
Status of Parameter Indications		Allowed

Note that the requested parameter values are fully specified by the QoS Class, but are included in this table for simple comparison. Only the achieved values and the requested/achieved Class number require signalling fields.

The network receiving this message determines its performance from entrance node to the destination, or to the most likely exit node to the best-next network. The network would add its contribution to the Currently Achieved fields (according to a specified set of summation rules for each parameter), and send these fields on to the next network or back toward the requesting user. Participating Networks can indicate their willingness to indicate specific parameter values (where a single negative preference overrides others). In case the requested QoS Class is not achieved, the response can contain the committed performance in excess of the offered Class, using the Currently Achieved values.

The ability for each network to enter and communicate its contribution to the achieved performance level is a network option, an example is shown below:

Table I-4 Example of accumulating and signalling current performance

	Requested	Network 1	Network 2	Currently Achieved
QoS Class	Class 0	Class 0	Class 0	Class 0
Mean Transfer Delay (IPTD)	100 ms	20 ms	10 ms	30 ms
99.9% - min Delay Var. (IPDV)	50 ms	10 ms	10 ms	15 ms
Loss (IPLR)	10^{-3}	$<10^{-3}$	$<10^{-3}$	$<10^{-3}$
Errored Packets (IPER)	10^{-4}	$<10^{-4}$	$<10^{-4}$	$<10^{-4}$
Status of Parameter Indications		Allowed	Allowed	Allowed

A complete tabulation of the accumulated performance would allow corrective network actions if the Requested Class were not achieved.

Summation rules are simple for transfer delay. Average values for each network are added to the currently achieved value. More study is needed to determine the summation rules for delay variation and other parameters.

I.3 Future Development of Classes to support Reliability and Priority Attributes

Reliability/Priority attributes are the same for User-Network and Network-Network signalling requirements. No formal standards exist with respect to the qualitative (e.g., number of priority classes) or quantitative (e.g., time-to-restore) aspects of reliability. To that extent, the following assumptions are made in determining reliability attributes:

- Reliability for a service can be expressed as a priority with which that service requires a particular type of network function (e.g., Connection Admission Control Priority). Hence, reliability can be requested in the form of a Priority Class for that specific network function.
- From the viewpoint of signalling, there will be a limited number of Priority Classes for all network functions in order to ensure scalability (e.g., 4 classes).

Two types of Priority Class attributes are defined:

- Connection Admission Control Priority Class: The urgency with which a service connection is desired (e.g., High, Normal, Best Effort).
 - Restoration Priority Class: The urgency with which a service requires successful restoration under failure conditions (e.g., High, Normal, Best Effort).
-