

Agenda Item: 7.1.2

Source: ITU-R Ad Hoc

Title: Proposed update of Section 5.1.1 of Rec. ITU-R M.1457

Document for: Approval

5.1 IMT-2000 CDMA Direct Spread

5.1.1 Overview of the radio interface

5.1.1.1 Introduction

The IMT-2000 radio-interface specifications for CDMA Direct Spread technology are developed by a partnership of SDOs (see Note 1). This radio interface is called Universal Terrestrial Radio Access (UTRA) FDD or Wideband CDMA (WCDMA).

NOTE 1 – Currently, these specifications are developed within the third generation partnership project (3GPP) where the participating SDOs are the Association of Radio Industries and Businesses (ARIB), China Wireless Telecommunication Standard Group (CWTS), the European Telecommunications Standards Institute (ETSI), T1 (Alliance for Telecommunications Industry Solutions (ATIS) Standards Committee T1), Telecommunications Technology Association (TTA) and Telecommunication Technology Committee (TTC).

These radio-interface specifications have been developed with the strong objective of harmonization with the TDD component (see § 5.3) to achieve maximum commonality. This was achieved by harmonization of important parameters of the physical layer. Furthermore, a common set of protocols in the higher layers is specified for both FDD and TDD.

In the development of this radio interface the CN specifications are based on an evolved GSM-MAP. However, the specifications include the necessary capabilities for operation with an evolved ANSI-41-based CN.

The radio-access scheme is Direct-Sequence CDMA (DS-CDMA) with information spread over approximately 5 MHz bandwidth using a chip rate of 3.84 Mchip/s. The radio interface is defined to carry a wide range of services to efficiently support both circuit-switched services (e.g. PSTN- and ISDN-based networks) as well as packet-switched services (e.g. IP-based networks). A flexible radio protocol has been designed where several different services such as speech, data and multimedia can simultaneously be used by a user and multiplexed on a single carrier. The defined radio-bearer services provide support for both real-time and non-real-time services by employing transparent and/or non-transparent data transport. The quality of service (QoS) can be adjusted in terms such as delay, bit error probability, and frame error ratio (FER).

The radio-interface specification includes enhanced features for High-Speed Downlink Packet Access (HSDPA), allowing for downlink packet-data transmission with peak data rates exceeding 8 Mbit/s and simultaneous high-speed packet data and other services such as speech on the single carrier.

WCDMA was originally specified for the IMT-2000 core bands identified in WARC-1992 and using 1920-1980 MHz as uplink and 2110-2170 MHz as downlink. In WRC-2000 additional spectrum for IMT-2000 was identified and subsequently as a complement to 3GPP Release99 the relevant specifications have been updated to also include the 1900 MHz, 1800 MHz, 850 MHz, and 800 MHz bands as well as a pairing of parts, or whole, of 1710-1770 MHz as uplink with whole, or parts, of 2110-2170 MHz as downlink. In addition a more general study has been performed considering the viable deployment of WCDMA in additional and diverse spectrum arrangements.

5.1.1.2 Radio access network architecture

The overall architecture of the radio access network is shown in Fig. 3.

The architecture of this radio interface consists of a set of radio network subsystems (RNS) connected to the CN through the Iu interface. An RNS consists of a radio network controller (RNC) and one or more entities called Node B. Node B is connected to the RNC through the Iub interface. Each Node B can handle one or more cells. The RNC is responsible for the handover decisions that require signalling to the user equipment (UE). In case macro diversity between different Node Bs is to be supported, the RNC comprises a combining/splitting function to support this. Node B can comprise an optional combining/splitting function to support macro diversity within a Node B. The RNCs of the RNS can be interconnected through the Iur interface. Iu and Iur are logical interfaces, i.e. the Iur interface can be conveyed over a direct physical connection between RNCs or via any suitable transport network.

Figure 4 shows the radio interface protocol architecture for the radio access network. On a general level, the protocol architecture is similar to the current ITU-R protocol architecture as described in Recommendation ITU-R M.1035. Layer 2 (L2) is split into the following sub-layers; radio link control (RLC), medium access control (MAC), Packet Data Convergence Protocol (PDCP) and Broadcast/Multicast Control (BMC). Layer 3 (L3) and RLC are divided into control (C-plane) and user (U-plane) planes. In the C-plane, L3 is partitioned into sub-layers where the lowest sub-layer, denoted as radio resource control (RRC), interfaces with L2. The higher-layer signalling such as mobility management (MM) and call control (CC) are assumed to belong to the CN. There are no L3 elements in this radio interface for the U-plane.

FIGURE 3
Radio access network architecture
 (Cells are indicated by ellipses)

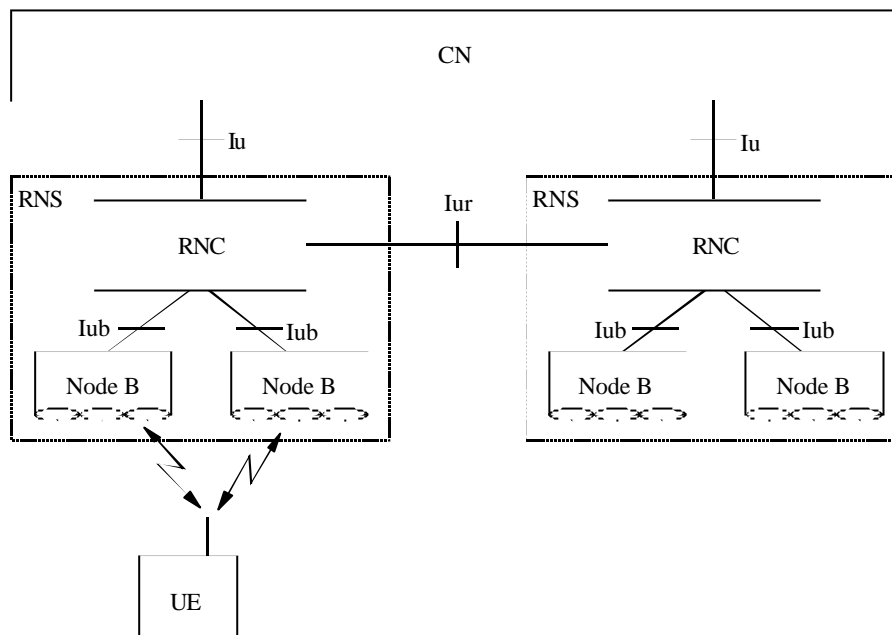

1457-03

Each block in Fig. 4 represents an instance of the respective protocol. Service access points (SAPs) for peer-to-peer communication are marked with circles at the interface between sub-layers. The SAP between MAC and the physical layer provides the transport channels. A transport channel is characterized by how the information is transferred over the radio interface (see Section 5.1.1.3.1 for an overview of the types of transport channels defined). The SAPs between RLC and the MAC sub-layer provide the logical channels. A logical channel is characterized by the type of information that is transferred over the radio interface. The logical channels are divided into control channels and traffic channels. The different types of logical channels are not further described in this overview. In the C-plane, the interface between RRC and higher L3 sub-layers (CC, MM) is defined by the general control (GC), notification (Nt) and dedicated control (DC) SAPs. These SAPs are not further discussed in this overview.

Also shown in Fig. 4 are connections between RRC and MAC as well as RRC and L1 providing local inter-layer control services (including measurement results). An equivalent control interface exists between RRC and the RLC sub-layer. These interfaces allow the RRC to control the configuration of the lower layers. For this purpose separate control SAPs are defined between RRC and each lower layer (RLC, MAC, and L1).

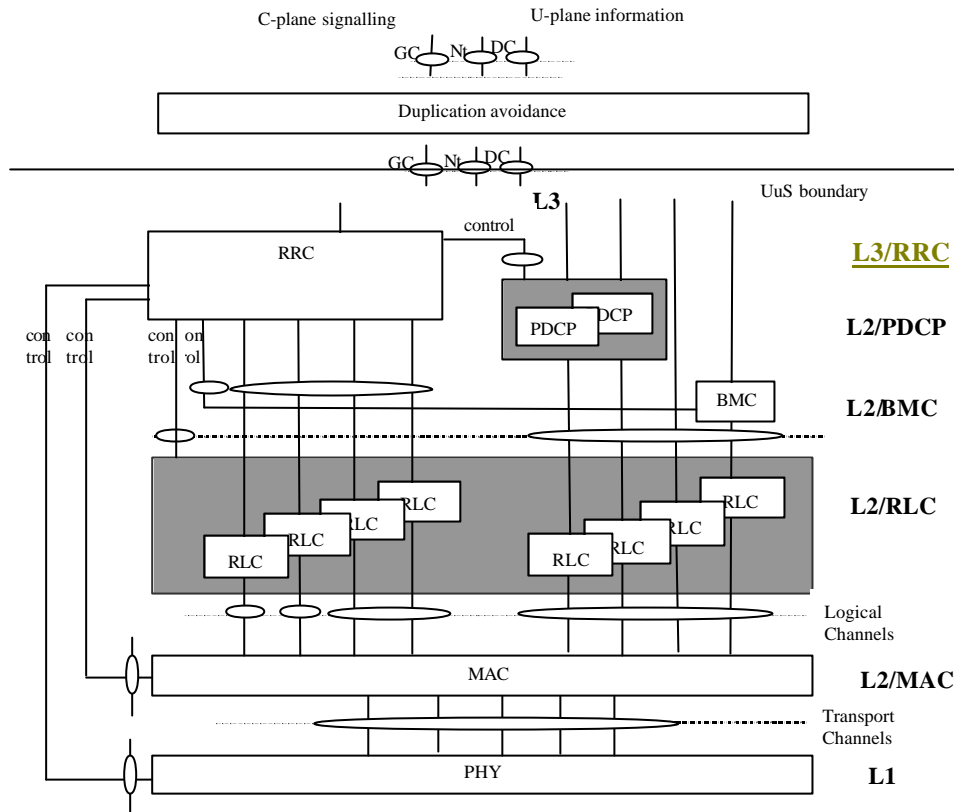

FIGURE 4

Radio interface protocol architecture of the RRC sublayer, (L2 and L1)

Figure 5 shows the general structure and some additional terminology definitions of the channel formats at the various sub-layer interfaces indicated in Fig. 4. The Figure indicates how higher layer service data units (SDUs) and protocol data units (PDUs) are segmented and multiplexed to transport blocks to be further treated by the physical layer (e.g. CRC handling). The transmission chain of the physical layer is exemplified in the next section.

5.1.1.3 Physical layer

5.1.1.3.1 Transport Channels

Transport channels are the services offered by the physical layer to MAC and higher layers. The general classification of transport channels is into two groups:

- ? Common transport channels where there is a need for explicit UE identification when a particular UE is addressed or a particular group of UEs are addressed.
- ? Dedicated transport channels where a UE is implicitly identified by the physical channel, i.e. code and frequency.

Common transport channel types are:

? **Random Access Channel (RACH)**

A contention based uplink channel used for transmission of relatively small amounts of data, e.g. for initial access or non-real-time dedicated control or traffic data.

? **Common Packet Channel (CPCH)**

A contention based uplink channel used for transmission of bursty data traffic. The common packet channel is shared by the UEs in a cell and therefore, it is a common resource. The CPCH is fast power controlled.

? **Forward Access Channel (FACH)**

A common downlink channel without closed-loop power control used for transmission of relatively small amount of data.

? **Downlink Shared Channel (DSCH)**

A downlink channel shared by several UEs carrying dedicated control or traffic data.

? **High-speed Downlink Shared Channel (HS-DSCH)**

A downlink channel served by several UEs carrying dedicated control or traffic data. HS-DSCH offers the possibility for high-speed downlink packet access through the support of higher-order modulation, adaptive modulation and coding, fast channel-dependent scheduling, and hybrid ARQ with soft combining.

? **Broadcast Channel (BCH)**

A downlink channel used for broadcast of system information into an entire cell.

? **Paging Channel (PCH)**

A downlink channel used for broadcast of control information into an entire cell allowing efficient UE sleep mode procedures. Currently identified information types are paging and notification. Another use could be UTRAN notification of change of BCCH information.

Dedicated transport channel types are:

? **Dedicated Channel (DCH)**

A channel dedicated to one UE used in uplink or downlink.

On each transport channel, a number of *Transport Blocks* are delivered to/from the physical layer once every *Transmission Time Interval* (TTI). To each transport channel, there is an associated *Transport Format* or set of transport formats. The transport format describes the physical properties of the transport channel, such as the TTI, the number of transport blocks per TTI, the number of bits per transport blocks, the coding scheme and coding rate, and the modulation scheme.

5.1.1.3.2 Physical layer functionality and building blocks

The physical layer includes the following functionality:

- error detection on transport channels and indication to higher layers;
- forward error correction (FEC) encoding/decoding of transport channels;
- multiplexing of transport channels and demultiplexing of coded composite transport channels;
- rate matching;
- mapping of coded composite transport channels on physical channels;
- data modulation and demodulation of physical channels;
- spreading and de-spreading of physical channels;
- radio characteristics measurements including FER, Signal-to-Interference (SIR), Interference Power Level, etc., and indication to higher layers;
- frequency and time (chip, bit, slot, frame) synchronization;

- power weighting and combining of physical channels;
- closed-loop power control;
- RF processing;
- support of UE positioning methods;
- beamforming;
- macro-diversity distribution/combining and soft handover execution.

Figure 6 gives the physical layer transmission chain for the DCH transport channel. The Figure shows how several transport channels can be multiplexed onto one or more dedicated physical data channels (DPDCH).

The cyclic redundancy check (CRC) provides for error detection of the transport blocks for the particular transport channel. The CRC can take the length zero (no CRC), 8, 12, 16 or 24 bits depending on the service requirements.

The transport block concatenation and code block segmentation functionality performs serial concatenation of those transport blocks that will be sent in one transmission time interval and any code block segmentation if necessary.

The types of channel coding defined are convolutional coding, turbo coding and no coding. Real-time services use only FEC encoding while non-real-time services uses a combination of FEC and ARQ. The ARQ functionality resides in the RLC sub-layer of Layer 2. The convolutional coding rates are 1/2 or 1/3 while the rate is 1/3 for turbo codes. The possible interleaving depths are 10, 20, 40 or 80 ms.

The radio frame segmentation performs padding of bits. The rate matching adapts any remaining differences of the bit rate so the number of outgoing bits fit to the available bit rates of the physical channels. Repetition coding and/or puncturing is used for this purpose.

The transport channel multiplexing stage combines transport channels in a serial fashion. This is done every 10 ms. The output of this operation is also called coded composite transport channels.

If several physical channels will be used to transmit the data, the split is made in the physical channel segmentation unit.

The downlink can use DTX on a slot-to-slot basis for variable rate transmission. The insertions could either be at fixed or at flexible positions.

For other transport-channel types, the physical-layer transmission chain is similar although not necessarily identical to that of DCH in Figure 6.

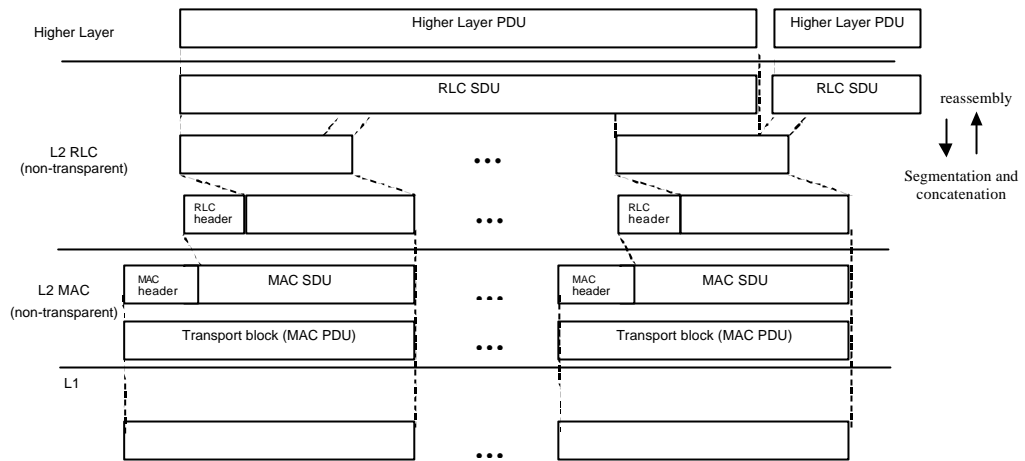
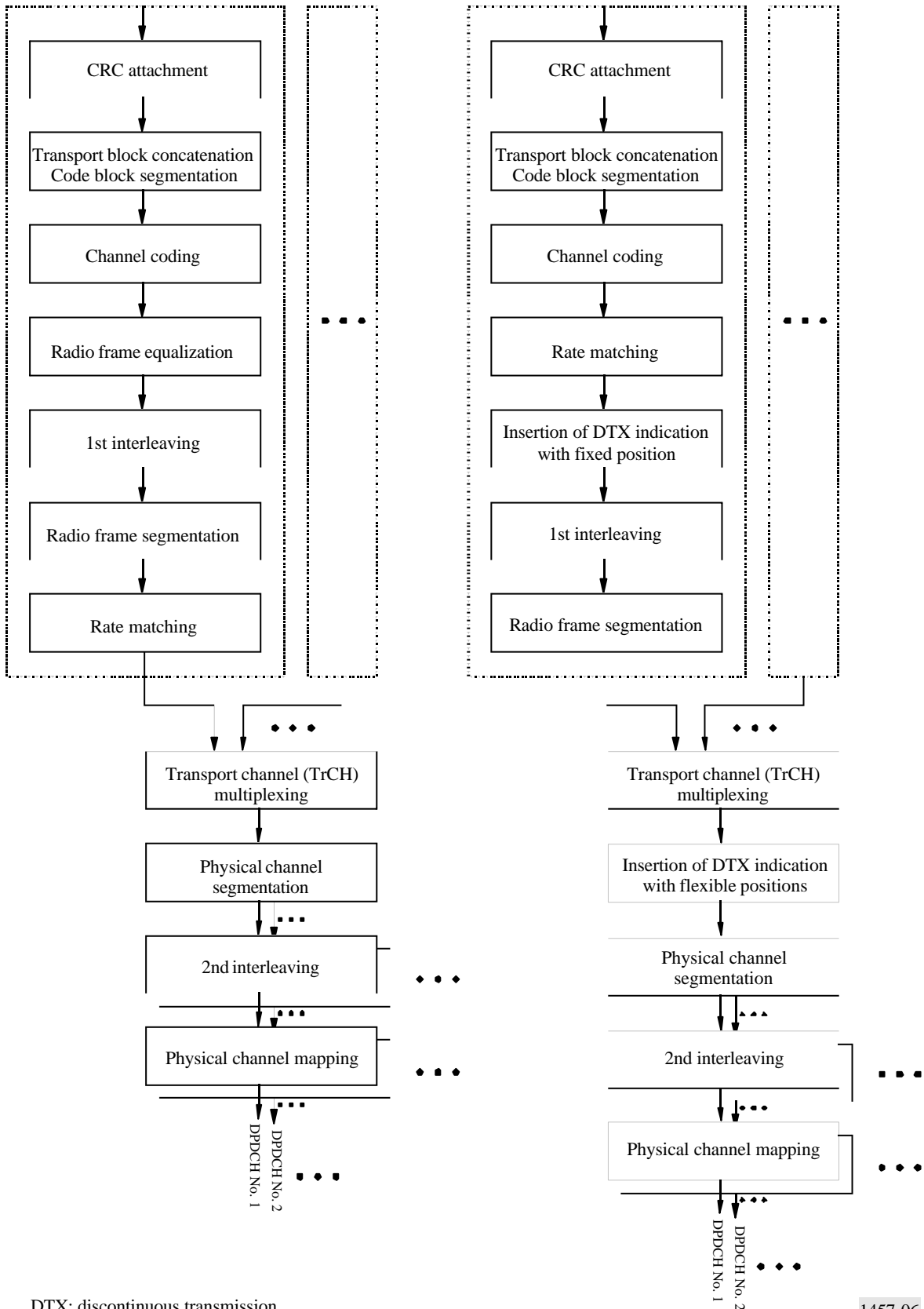

FIGURE 5

Data flow for a service using a non-transparent RLC and non-transparent MAC (see Sections 5.1.1.4.1-2 for further definitions of the MAC and RLC services and functionality)

FIGURE 6

Transport channel multiplexing structure (left: uplink; right: downlink)



DTX: discontinuous transmission

FIGURE 6
DCH transport channel multiplexing structure (left: uplink; right: downlink)

5.1.1.3.3 Transport channels to physical channel mapping

The transport channels are mapped onto the physical channels. Figure 7 shows the different physical channels and summarizes the mapping of transport channels onto physical channels. Each physical channel has its tailored slot content. The slot content for the uplink and downlink DPDCH/DPCCH, on to which the uplink and downlink DCH is mapped, is shown in Section 5.1.1.3.4.

5.1.1.3.4 Physical frame structure

The basic physical frame rate is 10 ms with 15 slots. Figure 8 shows the frame structure.

Figure 9 shows the content for a slot used by the DCH. The uplink physical channels DPDCH and DPCCH are I/Q multiplexed while the downlink channels are time multiplexed. The DPDCH, the channel where the user data is transmitted on, is always associated with a DPCCH containing Layer 1 control information. The transport format combination indicator (TFCI) field is used for indicating the demultiplexing scheme of the data stream. The TFCI field does not exist for combinations that are static (i.e. fixed bit rate allocations) or blind transport format detection is employed. The feedback information (FBI) field is used for transmit and site diversity functions. The transmit power control (TPC) bits are used for power control.

Transport Channels	Physical Channels
BCH	Primary Common Control Physical Channel (Primary CCPCH) (Downlink; 30 kbps fixed rate)
FACH	Secondary Common Control Physical Channel (Secondary CCPCH) (Downlink; Variable rate.)
PCH	Physical Random Access Channel (PRACH) (Uplink)
RACH	
CPCH	Physical Common Packet Channel (PCPCH) (Uplink)
DCH	Dedicated Physical Data Channel (DPDCH) (Downlink/Uplink)
	Dedicated Physical Control Channel (DPCCH) (Downlink/Uplink; Associated with a DPDCH)
DSCH	Physical Downlink Shared Channel (PDSCH) (Downlink)
HS-DSCH	Physical High-Speed-Downlink Shared Channel (PHSDSCH) (Downlink)
	HS-DSCH-related Shared Control Channel (HS-SCCH) (Downlink; used to carry downlink signalling related to HS-DSCH transmission)
	Synchronization Channel (SCH) (Downlink; uses part of the slot of primary CCPCH; used for cell search)
	Common Pilot Channel (CPICH) (Downlink, used as phase reference for other downlink physical channels)
	Acquisition Indicator Channel (AICH) (Downlink; used to carry acquisition indicator for the random access procedure)
	Paging Indicator Channel (PICH) (Downlink; used to carry page indicators to indicate the presence of a page message on the PCH)
	Access Preamble Acquisition Indicator Channel (AP-AICH)*
	CPCH Status Indicator Channel (CSICH)*
	Collision-Detection/Channel-Assignment Indicator Channel (CD/CA-ICH)* (*Downlink, channels for CPCH access procedure)

FIGURE 7

Transport channels, physical channels and their mapping

FIGURE 8
Basic frame structure

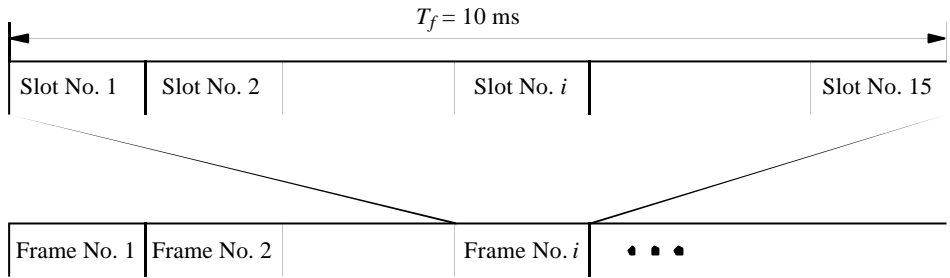

1457-08

FIGURE 8
Basic frame structure

FIGURE 9
The slot content for the DPDCH/DPCCH

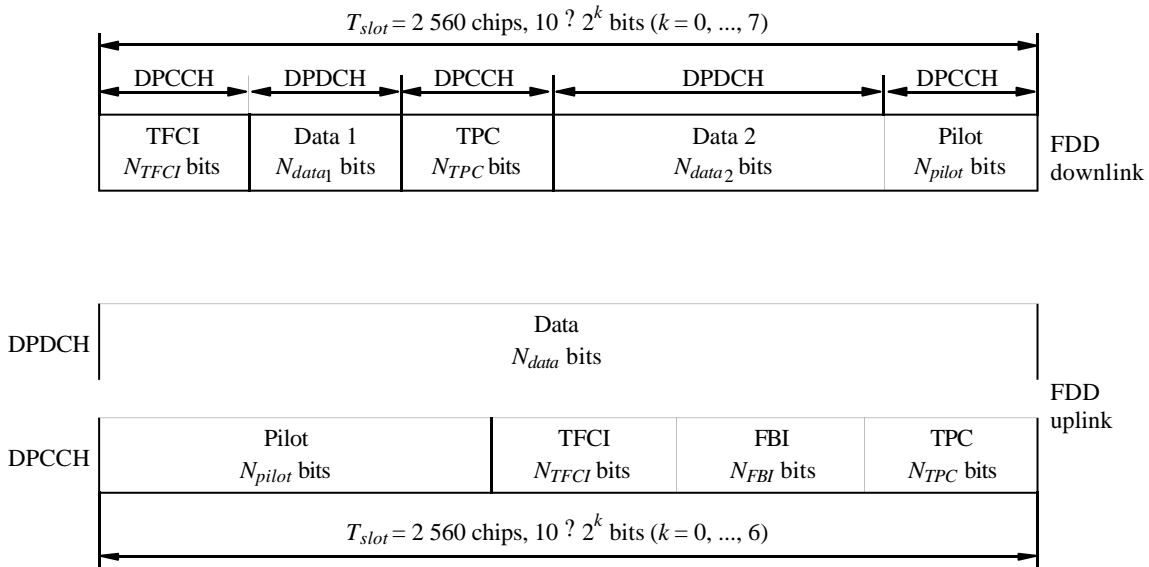

1457-09

For the uplink, the DPDCH bit rate can vary between 15 up to 960 kbit/s using spreading factors (SFs) (256 down to 4). To obtain higher bit rates for a user several physical channels can be used. The bit rate of the DPCCH is fixed to 15 kbit/s. For the downlink the DPDCH bit rate is variable between 15 up to 1 920 kbit/s with a SF ranging from 512 down to 4. Note that the symbol bit rate is equal to the channel bit rate for the uplink while it is half of the channel bit rate for the downlink.

A CPICH is defined. It is an unmodulated downlink channel, that is the phase reference for other downlink physical channels. There is always one primary CPICH in each cell. There may also be additional secondary CPICHs in a cell.

To be able to support inter-frequency handover as well as measurements on other carrier frequencies or carriers of other systems, like GSM, a compressed mode of operation is defined. The function is implemented by having some slots empty, but without deleting any user data. Instead the user data is transmitted in the remaining slots. The number of slots that is not used can be variable with a minimum of three slots (giving minimum idle lengths of at least 1.73 ms). The slots can be empty either in the middle of a frame or at the end and in the beginning of the consecutive frame. If and how often is controlled by the RRC functionality in Layer 3.

5.1.1.3.5 Spreading, modulation and pulse shaping

Uplink

Spreading consists of two operations. The first is the channelization operation, which transforms every data symbol into a number of chips, thus increasing the bandwidth of the signal. The number of chips per data symbol is called the SF. The second operation is the scrambling operation, where a scrambling code is applied to the spread signal.

In the channelization operation, data symbol on so-called I- and Q-branches are independently multiplied with a code. The channelization codes are orthogonal variable spreading factor (OVSF) codes that preserve the orthogonality between a user's different physical channels. With the scrambling operation, the resultant signals on the I- and Q-branches are further multiplied by complex-valued scrambling code, where I and Q denote real and imaginary parts, respectively. Note that before complex multiplication binary values 0 and 1 are mapped to $+1$ and -1 , respectively. Figure 10 illustrates the spreading and modulation for the case of multiple uplink DPDCHs. Note that this figure only shows the principle, and does not necessarily describe an actual implementation. Modulation is dual-channel QPSK (i.e. separate BPSK on I- and Q-channel), where the uplink DPDCH and DPCCH are mapped to the I and Q branch respectively. The I and Q branches are then spread to the chip rate with two different channelization codes and subsequently complex scrambled by a UE specific complex scrambling code C_{scramb} . There are 2^{24} uplink-scrambling codes. Either short (256 chips from the family of S(2) codes) or long (38 400 chips equal to one frame length, gold code-based) scrambling codes is used on the uplink. The short scrambling code is typically used in cells where the BS is equipped with an advanced receiver, such as a multi-user detector or interference canceller whereas the long codes gives better interference averaging properties.

The pulse-shaping filters are root-raised cosine with roll-off $\beta = 0.22$ in the frequency domain.

The modulation of both DPCCH and DPDCH is BPSK. The modulated DPCCH is mapped to the Q-branch, while the first DPDCH is mapped to the I-branch. Subsequently added DPDCHs are mapped alternatively to the I- or Q-branches.

Downlink

Figure 11 illustrates the spreading and modulation for the downlink DPDCH/DPCCH. Data modulation is QPSK where each pair of two bits are serial-to-parallel (S/P) converted and mapped to the I- and Q-branch respectively. The I- and Q-branch are then spread to the chip rate with the same channelization code C_{ch} (real spreading) and subsequently scrambled by the scrambling code C_{scramb} (complex scrambling).

The channelization codes are the same codes as used in the uplink that preserve the orthogonality between downlink channels of different rates and SFs. There are a total of $512 \times 512 = 262\,144$ scrambling codes, numbered 0 to 262 143. The scrambling codes are divided into 512 sets each of a primary scrambling code and 511 secondary scrambling codes. Each cell is allocated one and only one primary scrambling code. The primary CCPCH is always transmitted using the primary

scrambling code. The other downlink physical channels can be transmitted with either the primary scrambling code or a secondary scrambling code from the set associated with the primary scrambling code of the cell.

The pulse-shaping filters are root-raised cosine with roll-off $\beta = 0.22$ in the frequency domain.

Downlink spreading for downlink physical channels other than the downlink DPCH is very similar. For the physical channel to which HS-DSCH is mapped, higher-order data modulation can be used in addition to QPSK.

FIGURE 10
Spreading/modulation for uplink DPDCH/DPCCH

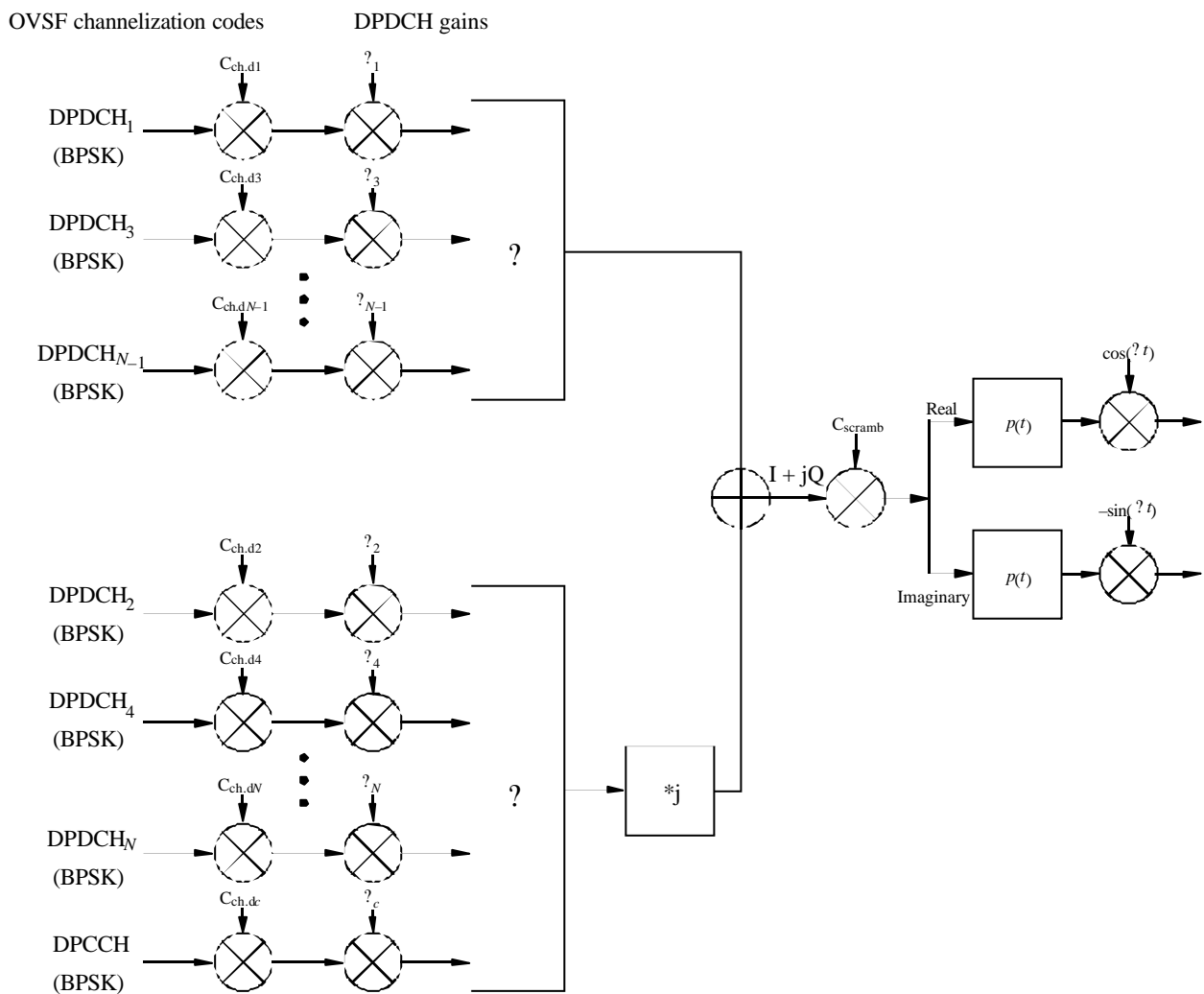
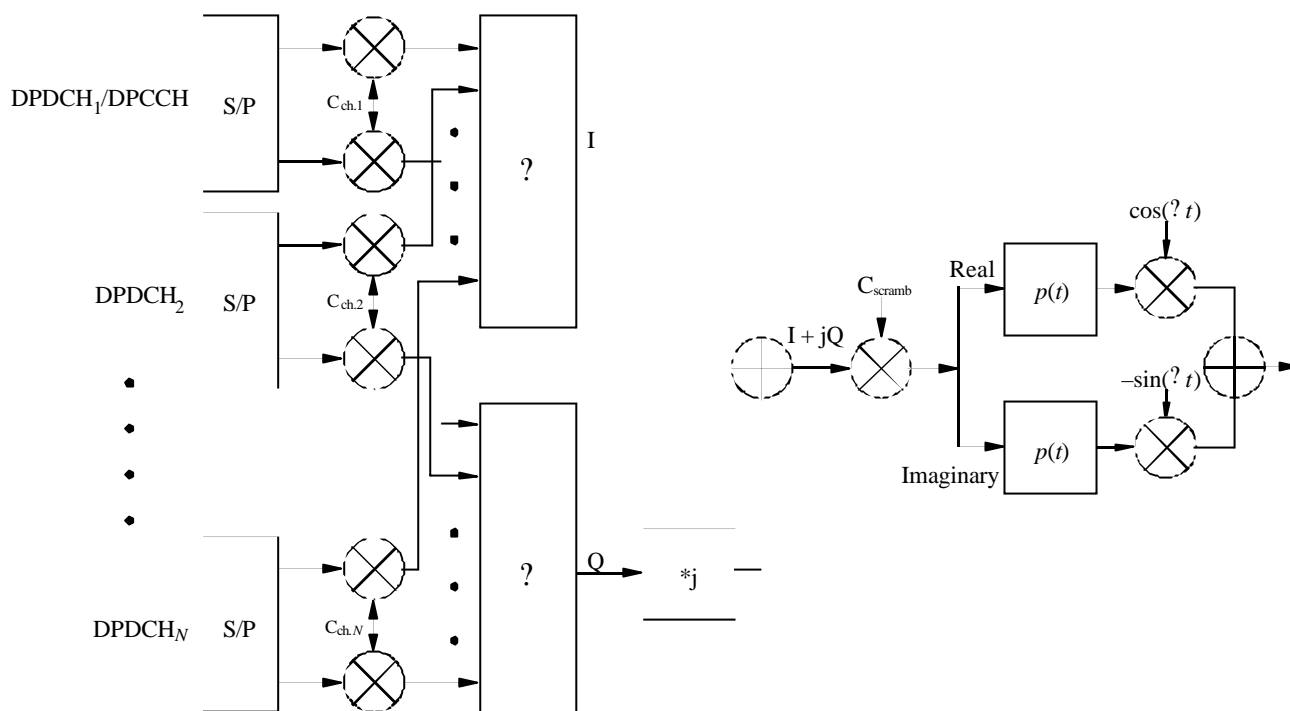

FIGURE 11
Spreading/modulation for downlink DPDCH/DPCCH



1457-11

5.1.1.4 Layer 2

5.1.1.4.1 MAC sub-layer

The MAC sub-layer is responsible for the handling of the data streams coming from the RLC and RRC sub-layers. It provides an unacknowledged transfer mode service to the upper layers. The interface to the RLC sub-layer is through logical channel service access points. It also re-allocates radio resources on request by the RRC sub-layer as well as provides measurements to the upper layers. The logical channels are divided into control channels and traffic channels. Thus, the functionality handles issues like:

- mapping of the different logical channels to the appropriate transport channels and selection of appropriate transport format for the transport channels based on the instantaneous source bit rate, and optimization of the HS-DSCH transport channel;
- multiplexing/demultiplexing of the PDUs to/from transport blocks which are thereafter further treated by the physical layer;
- dynamic switching between common and dedicated transport channels based on information from the RRC sub-layer;
- priority issues for services to one UE according to information from higher layers and physical layer (e.g. available transmit power level) as well as priority handling between UEs by means of dynamic scheduling in order to increase spectrum efficiency;
- monitoring of traffic volume that can be used by the RRC sub-layer;
- hybrid ARQ with soft combining in case of the HS-DSCH transport channel.

Figure 12 shows the possibilities of mapping the logical dedicated traffic channel (DTCH) onto transport channels. There are possibilities to map onto common transport channels as well as dedicated transport channels. The choice of mapping could be determined on e.g. the DTCH traffic intensity..

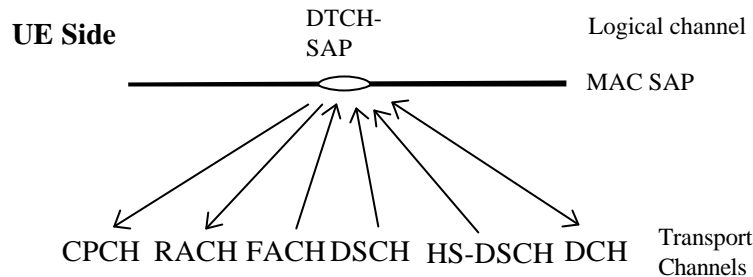

FIGURE 12

**The possible transport channel mappings of the dedicated traffic channel (DTCH)
(The arrows show the direction of the channel (UE side).
The directions are reversed from the network side)**

5.1.1.4.2 RLC sub-layer

The RLC sub-layer provides three different types of data transfer modes:

- *Transparent data transfer.* This service transmits higher layer PDUs without adding any protocol information, possibly including segmentation/reassemble functionality.
- *Unacknowledged data transfer.* This service transmits higher layer PDUs without guaranteeing delivery to the peer entity. The unacknowledged data transfer mode has the following characteristics:
 - a) detection of erroneous data: The RLC sub-layer shall deliver only those SDUs to the receiving higher layer that are free of transmission errors by using the sequence-number check function;
 - b) unique delivery: The RLC sub-layer shall deliver each SDU only once to the receiving upper layer using duplication detection function;
 - c) immediate delivery: The receiving RLC sub-layer entity shall deliver a SDU to the higher layer receiving entity as soon as it arrives at the receiver.
- *Acknowledged data transfer.* This service transmits higher layer PDUs and guarantees delivery to the peer entity. In case RLC is unable to deliver the data correctly, the user of RLC at the transmitting side is notified. For this service, both in-sequence and out-of-sequence delivery are supported. In many cases a higher layer protocol can restore the order of its PDUs. As long as the out-of-sequence properties of the lower layer are known and controlled (i.e. the higher layer protocol will not immediately request retransmission of a missing PDU) allowing out-of-sequence delivery can save memory space in the receiving RLC. The acknowledged data transfer mode has the following characteristics:
 - a) error-free delivery: error-free delivery is ensured by means of retransmission. The receiving RLC entity delivers only error-free SDUs to the higher layer;
 - b) unique delivery: the RLC sub-layer shall deliver each SDU only once to the receiving upper layer using duplication detection function;

- c) in-sequence delivery: RLC sub-layer shall provide support for in-order delivery of SDUs, i.e. RLC sub-layer should deliver SDUs to the receiving higher layer entity in the same order as the transmitting higher layer entity submits them to the RLC sub-layer;
- d) out-of-sequence delivery: alternatively to in-sequence delivery, it shall also be possible to allow that the receiving RLC entity delivers SDUs to higher layer in different order than submitted to RLC sub-layer at the transmitting side.

It also provides for RLC connection establishment/release. As well as QoS setting and notification to higher layers in case of unrecoverable errors.

An example of the data flow for non-transparent (acknowledged/unacknowledged) data transfer is shown in Fig. 5.

5.1.1.4.3 PDCP sub-layer

PDCP provides transmission and reception of Network PDUs in acknowledged, unacknowledged and transparent RLC mode.

It is responsible for the mapping of Network PDUs from one network protocol to one RLC entity and it provides compression in the transmitting entity and decompression in the receiving entity of redundant Network PDU control information (header compression/ decompression).

5.1.1.4.4 BMC sub-layer

The BMC provides a broadcast/multicast transmission service in the user plane on the radio interface for common user data in transparent or unacknowledged mode.

It can handle functionalities such as storage, scheduling and transmission of BMC messages.

5.1.1.5 Layer 3 (RRC sub-layer)

The RRC sub-layer handles the control plane signalling of Layer 3 between the UEs and the radio interface. In addition to the relation with the upper layers (such as CN) the following main functions are performed:

- *Broadcast of information provided by the non-access stratum (CN)* – The RRC layer performs system information broadcasting from the network to all UEs. The system information is normally repeated on a regular basis. This function supports broadcast of higher layer (above RRC) information. This information may be cell specific or not. As an example RRC may broadcast CN location service area information related to some specific cells.
- *Broadcast of information related to the access stratum* – The RRC layer performs system information broadcasting from the network to all UEs. This function supports broadcast of typically cell-specific information.
- *Establishment, maintenance and release of an RRC connection between the UE and the radio access network* – The establishment of an RRC connection is initiated by a request from higher layers at the UE side to establish the first signalling connection for the UE. The establishment of an RRC connection includes an optional cell re-selection, an admission control, and a Layer 2 signalling link establishment.

- *Establishment, reconfiguration and release of radio access bearers* – The RRC layer will, on request from higher layers, perform the establishment, reconfiguration and release of radio access bearers in the user plane. A number of radio access bearers can be established to an UE at the same time. At establishment and reconfiguration, the RRC layer performs admission control and selects parameters describing the radio access bearer processing in Layer 2 and Layer 1, based on information from higher layers.
- *Assignment, reconfiguration and release of radio resources for the RRC connection* – The RRC layer handles the assignment of radio resources (e.g. codes) needed for the RRC connection including needs from both the control and user plane. The RRC layer may reconfigure radio resources during an established RRC connection. This function includes coordination of the radio resource allocation between multiple radio bearers related to the same RRC connection. RRC controls the radio resources in the uplink and downlink such that UE and the radio access network can communicate using unbalanced radio resources (asymmetric uplink and downlink). RRC signals to the UE to indicate resource allocations for purposes of handover to GSM or other radio systems.
- *RRC connection mobility functions* – The RRC layer performs evaluation, decision and execution related to RRC connection mobility during an established RRC connection, such as handover, preparation of handover to GSM or other systems, cell re-selection and cell/paging area update procedures, based on e.g. measurements done by the UE.
- *Paging/notification* – The RRC layer can broadcast paging information from the network to selected UEs. The RRC layer can also initiate paging during an established RRC connection.
- *Control of requested QoS* – This function ensures that the QoS requested for the radio access bearers can be met. This includes the allocation of a sufficient number of radio resources.
- *UE measurement reporting and control of the reporting* – The measurements performed by the UE are controlled by the RRC layer, in terms of what to measure, when to measure and how to report, including both this radio interface and other systems. The RRC layer also performs the reporting of the measurements from the UE to the network.
- *Outer loop power control* – The RRC layer controls setting of the target of the closed-loop power control.
- *Control of ciphering* – The RRC layer provides procedures for setting of ciphering (on/off) between the UE and the radio access network.
- *Initial cell selection and re-selection in idle mode* – Selection of the most suitable cell based on idle mode measurements and cell selection criteria.
- *Arbitration of the radio resource allocation between the cells* – This function shall ensure optimal performance of the overall radio access network capacity.

5.1.1.6 Summary of major technical parameters

Parameter	Value	Reference to § 5.1.2
Multiple access technique and duplexing scheme	Multiple access: DS-CDMA Duplexing: FDD	5.1.2.1.1
Chip rate (Mchip/s)	3.84	5.1.2.1.4
Frame length and structure	Frame length: 10 ms Slot length: 10/15 ms. TTI: 10 ms, 20 ms, 40 ms, 80 ms, 2 ms (HS-DSCH only)	5.1.2.1.2
Occupied bandwidth	Less than 5 MHz	5.1.2.4.1, 5.1.2.4.3
Adjacent channel leakage power ratio (ACLR) (transmitter side)	UE (UE power class: ? 21 dBm and +24 dBm): ACLR (5 MHz) ? 33 dB ACLR (10 MHz) ? 43 dB BS: ACLR (5 MHz) ? 45 dB ACLR (10 MHz) ? 50 dB	5.1.2.4.1 5.1.2.4.3
Adjacent channel selectivity (ACS) (receiver side)	UE: ACS (5 MHz) ? 33 dB BS: ACS (5 MHz) ? 45 dB	5.1.2.4.1 5.1.2.4.3
Random access mechanism	Acquisition indication based random-access mechanism with power ramping on preamble followed by message	5.1.2.1.2 5.1.2.1.5
Pilot structure	Uplink: dedicated pilots Downlink: common and/or dedicated pilots	5.1.2.1.2
Inter-base station asynchronous/synchronous operation	Asynchronous; synchronous	5.1.2.1.5 5.1.2.4.3