

Presentation of Specification to TSG or WG

Presentation to: TSG-RAN Meeting #11

Document for presentation: TR 25.844 Version 2.0.0

Presented for: Approval

Abstract of document:

The present document is a technical report that summarises the work on the UTRAN Release 2000 work item "Radio Access Bearer Support Enhancements". The work items comprises of five areas of study:

- 1) Robust header compression
- 2) PDCP multiplexing
- 3) Variable Iu frame formats and unequal error protection over Uu
- 4) Channel type switching per logical channel
- 5) Header removal

Each study area includes the requirements of the proposed feature, a description of the basic mechanism and a discussion of the issues involved. A recommended solution is provided and impacts to other RAN WGs are analysed.

Changes since last presentation to TSG-RAN Meeting:

- 1) The Internet Engineering Steering Group (IESG) has approved ROHC as a proposed standard. The TR and associated CRs for Release 4 have been updated to reflect the new RFC numbers for the following:

RFC 3095: ROHC (Robust Header Compression): Framework and four profiles: RTP, UDP, ESP, and uncompressed.

RFC 3096: Requirements for robust IP/UDP/RTP header compression..
- 2) RFC 3095 (ROHC) has two types of parameters: configuration and implementation. The configuration parameters are mandatory and these are signalled by RRC. The implementation parameters are optional and are dependant on the implementation. However, these do not cause interoperability problems if used differently in implementations. All the ROHC configuration and implementation parameters are included in the TR with a recommendation of which implementation parameters are to be used in 3GPP.
- 3) Handling of ROHC during; a) SRNS relocation and b) Combined HHO and SRNS relocation was included. Immediately after relocation, the ROHC protocol will revert back to the initial state and in the U-mode (uni-directional mode). This will mean that full/complete IP headers are sent, establishing the context in the target SRNC and UE as if ROHC was set up for the first time. Context relocation of the header compression states is not recommended for Release 4 and could be studied for later releases.
- 4) Minor editorial corrections, update of references etc.
- 5) Header Removal was added to the scope and any work would be lead by TSG GERAN.
- 6) The RAN3 component of the WI was the "Variable Iu frame formats and unequal error protection". The work has just begun and therefore this would not be included in Release 4.
- 7) The ROHC part of the TR was finalised and so recommended for Release 4. This was the only item of the TR that was worked on and completed. All other areas are recommended as not for Release 4 and the applicability for future releases is FFS.
- 8) The TR was completed by making recommendations on all the areas within the WI (refer to the abstract above) and a review of the impacts to the other RAN WGs. The TR was approved as v2.0.0. in RAN2#19.

-
- 9) As the TR was approved in RAN2#19, the associated CR to RRC was presented and agreed in the RAN2#19 meeting, including ROHC in Release 4.
 - 10) A CR was provided to PDCP to include ROHC in Release 4 according to 5.1.10.3.2 of this TR and this was agreed in RAN2#19.
 - 11) A CR was provided to 25.306 to include ROHC in Release 4 and that was agreed in RAN2#19.

Outstanding Issues:

None.

Contentious Issues:

None.

3GPP TR 25.844 V2.0.0 (2001-03)

Technical Report

3rd Generation Partnership Project; Technical Specification Group Radio Access Network; Radio Access Bearer Support Enhancements (Release 4)



The present document has been developed within the 3rd Generation Partnership Project (3GPP™) and may be further elaborated for the purposes of 3GPP.

The present document has not been subject to any approval process by the 3GPP Organizational Partners and shall not be implemented. This Specification is provided for future development work within 3GPP only. The Organizational Partners accept no liability for any use of this Specification. Specifications and reports for implementation of the 3GPP™ system should be obtained via the 3GPP Organizational Partners' Publications Offices.

Keywords

<keyword[, keyword]>

3GPP

Postal address

3GPP support office address

650 Route des Lucioles - Sophia Antipolis
Valbonne - FRANCE
Tel.: +33 4 92 94 42 00 Fax: +33 4 93 65 47 16

Internet

<http://www.3gpp.org>

Copyright Notification

No part may be reproduced except as authorized by written permission.
The copyright and the foregoing restriction extend to reproduction in all media.

© 2000, 3GPP Organizational Partners (ARIB, CWTS, ETSI, T1, TTA, TTC).
All rights reserved.

Contents

Foreword.....	5
1 Scope	6
2 References	6
3 Abbreviations	7
3.1 Abbreviations	7
4 Requirements.....	7
5 Study Areas	7
5.1 Robust header compression.....	7
5.1.1 Introduction	7
5.1.2 Existing header compression schemes.....	8
5.1.3 IETF Robust header compression working group	8
5.1.4 ROHC compression and decompression states	8
5.1.4.1 IR State	9
5.1.4.2 FO State.....	9
5.1.4.3 SO State.....	9
5.1.5 Modes and mode transitions	9
5.1.6 State transitions	10
5.1.6.1 Uni-directional mode.....	10
5.1.6.1.1 Compressor	10
5.1.6.1.2 Decompressor	10
5.1.6.2 Bi-directional optimistic	11
5.1.6.2.1 Compressor	11
5.1.6.2.2 Decompressor	11
5.1.6.3 Bi-directional reliable.....	11
5.1.6.3.1 Compressor	11
5.1.6.3.2 Decompressor	12
5.1.6.4 Compressor and decompressor logic	12
5.1.7 Packet types	12
5.1.8 Packet formats	12
5.1.9 Packet format description	13
5.1.10 ROHC Configuration.....	13
5.1.10.1 Profiles	13
5.1.10.1.1 Context for Uncompressed Packets	14
5.1.10.2 Context Identifier	14
5.1.10.3 0-octet-CID	15
5.1.10.3.1 Introducing a new PDU Type for ROHC packets.....	16
5.1.10.3.2 Using the same PDCP PDU type for ROHC and RFC2507	16
5.1.10.4 Segmentation	17
5.1.10.5 Packet_Sizes_Allowed.....	17
5.1.10.6 Feedback	17
5.1.10.7 Example PDCP Configuration	17
5.1.11 ROHC primitives and parameters.....	18
5.1.11.1 ROHC Primitives at the compressor	18
5.1.11.1.1 CONTEXT_REINITIALIZATION	18
5.1.11.2 ROHC Primitives at the decompressor	18
5.1.11.2.1 MODE.....	18
5.1.11.2.2 CLOCK_RESOLUTION	18
5.1.11.2.3 Reverse_decompression_DEPTH.....	18
5.1.11.3 Summary of ROHC Parameters.....	18
5.1.11.3.1 Configuration Parameters	19
5.1.11.3.2 Implementation Parameters.....	19
5.1.13 ROHC Reconfiguration	20
5.1.14 ROHC with SRNS relocation.....	20
5.1.14.1 No context transfer.....	20

5.1.14.2	Context transfer.....	22
5.2	PDCP multiplexing	22
5.3	Variable Iu frame formats and unequal error protection	23
5.4	Channel type switching per logical channel.....	23
5.5	Header removal	23
6	Impacts on RAN WGs.....	23
6.1	WG1.....	23
6.1.1	Robust header compression	23
6.1.2	PDCP multiplexing.....	23
6.1.3	Variable Iu frame formats and unequal error protection over Uu.....	23
6.1.4	Channel type switching per logical channel	23
6.1.5	Header removal	23
6.2	WG2.....	24
6.2.1	Robust Header Compression	24
6.2.1.1	Radio Resource Control 25.331.....	24
6.2.1.2	Packet Data Convergence Protocol 25.323	24
6.2.1.3	UE Radio Access Capabilities TS 25.306	24
6.2.2	PDCP multiplexing.....	24
6.2.3	Variable Iu frame formats and unequal error protection over Uu.....	24
6.2.4	Channel type switching per logical channel	24
6.2.5	Header removal	24
6.3	WG3.....	25
6.3.1	Robust header compression	25
6.3.2	PDCP multiplexing.....	25
6.3.3	Variable Iu frame formats and unequal error protection over Uu.....	25
6.3.4	Channel type switching per logical channel	25
6.3.5	Header removal	25
6.4	WG4.....	25
6.4.1	Robust header compression	25
6.4.2	PDCP multiplexing.....	25
6.4.3	Variable Iu frame formats and unequal error protection over Uu.....	25
6.4.4	Channel type switching per logical channel	25
6.4.5	Header removal	25
7	Recommendations	25
7.1	Robust header compression.....	25
7.2	PDCP multiplexing	26
7.3	Variable Iu frame formats and unequal error protection over Uu	26
7.4	Channel type switching per logical channel.....	26
7.5	Header removal	26
8	Release 99 Specification Impacts.....	26
Annex A: Change history		27

Foreword

This Technical Report has been produced by the 3rd Generation Partnership Project (3GPP).

The contents of the present document are subject to continuing work within the TSG and may change following formal TSG approval. Should the TSG modify the contents of the present document, it will be re-released by the TSG with an identifying change of release date and an increase in version number as follows:

Version x.y.z

where:

- x the first digit:
 - 1 presented to TSG for information;
 - 2 presented to TSG for approval;
 - 3 or greater indicates TSG approved document under change control.
- y the second digit is incremented for all changes of substance, i.e. technical enhancements, corrections, updates, etc.
- z the third digit is incremented when editorial only changes have been incorporated in the document.

1 Scope

The present document is a technical report that summarises the work on the UTRAN Release 2000 work item "Radio Access Bearer Support Enhancements". The work items comprises of five areas of study:

- 1) Robust header compression
- 2) PDCP multiplexing
- 3) Variable Iu frame formats and unequal error protection over Uu
- 4) Channel type switching per logical channel
- 5) Header removal

Each study area includes the requirements of the proposed feature, a description of the basic mechanism and a discussion of the issues involved. A recommended solution is provided and impacts to other RAN WGs are analysed.

2 References

The following documents contain provisions which, through reference in this text, constitute provisions of the present document.

- References are either specific (identified by date of publication, edition number, version number, etc.) or non-specific.
- For a specific reference, subsequent revisions do not apply.
- For a non-specific reference, the latest version applies. In the case of a reference to a 3GPP document (including a GSM document), a non-specific reference implicitly refers to the latest version of that document *in the same Release as the present document*.

- [1] 3GPP TS 25.322: "RLC Protocol Specification".
- [2] 3GPP TS 25.323: "PDCP Protocol Specification".
- [3] 3GPP TS 25.331: "RRC Protocol Specification".
- [4] 3GPP TS 25.413: "UTRAN Iu Interface: RANAP Signalling".
- [5] 3GPP TS 25.415: "UTRAN Iu Interface: CN-RAN User Plane Protocol".
- [6] IETF RFC 3095: "RObust Header Compression (ROHC): Framework and four profiles: RTP, UDP, ESP, and uncompressed".
- [7] IETF RFC 1144, February 1990: "Compressing TCP/IP Headers for Low-Speed Serial Links".
- [8] IETF RFC 2507, February 1999: "IP Header Compression".
- [9] IETF RFC 2508, February 1999: "Compressing IP/UDP/RTP Headers for Low-Speed Serial Links".
- [10] IETF RFC 2509, February 1999: "IP Header Compression over PPP".
- [11] 3GPP TS 23.060: "General Packet Radio Service (GPRS); Service description; Stage 2".
- [12] 3GPP TS 25.303: "Interlayer Procedures in Connected Mode".
- [13] Internet-Draft (work in progress), 7 February 2001, <draft-ietf-rohc-rtp-lower-layer-guidelines-01.txt>: "Lower Layer Guidelines for Robust RTP/UDP/IP Header Compression".
<http://www.ietf.org/internet-drafts/draft-ietf-rohc-rtp-lower-layer-guidelines-01.txt>

- [14] IETF RFC 3096: "Requirements for robust IP/UDP/RTP header compression".
- [15] M. Degermark, H. Hannu, L.E. Jonsson, K. Svanbro, "Evaluation of CRTP Performance over Cellular Radio Networks", IEEE Personal Communication Magazine, Volume 7, number 4, Aug. 2000 pp. 20-25
- [16] 3GPP TS 43.051: "GERAN Overall Description – Stage 2".

3 Abbreviations

3.1 Abbreviations

For the purposes of the present document, the following abbreviations apply:

AS	Access Stratum
CID	Context ID
ESP	Encapsulating Security Payload Header
GERAN	GSM/EDGE Radio Access Network
HC	Header Compression
ID	Identifier
IE	Information Element
IETF	Internet Engineering Task Force
IP	Internet Protocol
PID	Packet ID
RNC	Radio Network Controller
ROHC	Robust Header Compression
RTP	Realtime Transmission Protocol
TCP	Transmission Control Protocol
UDP	User Datagram Protocol
UE	User Equipment
UMTS	Universal Mobile Telecommunications System
UTRAN	UMTS Terrestrial Radio Access Network

4 Requirements

5 Study Areas

5.1 Robust header compression

5.1.1 Introduction

Header compression of IP flows is possible due to the fact that the fields in the headers of IP packets are either constant or changing in a known pattern between consecutive packets in the same flow. It is possible to send only information regarding the nature of the changing fields of the headers with respect to the reference packet in the same IP flow.

The benefit is a significant reduction in header overhead and hence an increase in bandwidth efficiency. For example, IP based voice applications require an IP header; 20 octets for IPv4 and 40 octets for IPv6, a UDP header of 8 octets and a RTP header of 12 octets. A total of 40 octets for the headers are required to transport the voice payload for IPv4 and 60 octets for IPv6. When this is compared to the size of the payload, which is of the order of 15-32 bytes (depending on the codec and frame size/rate), the gains from compressing the headers is quite apparent.

In order for header compression to work there must be a compressor and a decompressor. A context is basically a snapshot of the complete (uncompressed) headers of an IP flow. This context is always exchanged from the compressor to decompressor at initialisation of the header compression scheme. After that the context is updated according to some criteria which is dependent on the header compression scheme.

During normal operation, the compressor will always try to send compressed headers instead of full headers. The compressed header represents the relative changes to a reference packet in the same IP flow and therefore the changes are relatively small.

Some header compression schemes may employ feedback from the decompressor to the compressor to indicate the current context state in the decompressor. A result of this could be to send sufficient information to update the context in the decompressor. With the basic tools of header compression it is possible to define a protocol that will work on any link layer technology.

5.1.2 Existing header compression schemes

The former header compression schemes that are standardised in the IETF are specified in references [7], [8] and [9]. However, these schemes were not designed for cellular usage and especially [9] that compress real-time IP headers do not cope well over unreliable links such as the cellular environment. Also, wireless links exhibit long round trip times (RTT) and therefore loss of synchronisation of contexts between the compressor and decompressor can result in a large loss of packets until synchronisation is achieved [15].

As IP based multimedia services are increasing rapidly, a need has arisen to support real-time IP services in UTRAN. However, with the added difficulties due the radio interface as described earlier there is a need for header compression to be robust in the cellular environment.

5.1.3 IETF Robust header compression working group

It is the task of the IETF WG called "Robust Header Compression" or ROHC to standardise a header compression protocol that is suitable for wireless links. A robust scheme should tolerate errors on the link over which header compression takes place (including both frame losses and residual bit errors) without losing additional packets, introducing additional errors or using more bandwidth.

The ROHC protocol is currently the only protocol that is being standardised by the ROHC WG. ROHC framework handles several compression profiles. Currently it contains profiles that are able to compress RTP/UDP/IP, UDP/IP and ESP/IP streams for both IPv4 and IPv6. This study area in this technical report will investigate how the ROHC protocol will be realised for Release 4.

5.1.4 ROHC compression and decompression states

The compressor starts in the lowest compression state and gradually transitions to higher compression states. The general principle is the compressor will always operate in the highest possible compression state, under the constraint that the compressor has sufficient confidence that the decompressor has the information necessary to decompress a compressed header.

In the reliable mode, that confidence comes from receipt of ACKs from the decompressor. Otherwise, that confidence comes from sending the information a certain number of times, utilising a CRC calculated over the uncompressed RTP/UDP/IP header, and from not receiving NACKs (negative acknowledgements).

The compressor may also transition back to a lower compression state when necessary.

For IP/UDP/RTP, IP/UDP and ESP/IP compression profiles, the three compressor states are:

- Initialisation/Refresh (IR)
- First Order (FO)
- Second Order (SO)

5.1.4.1 IR State

The purpose of this state is to set up or refresh the context between the compressor and decompressor. The information that is sent from the compressor may contain static and non-static fields in uncompressed form (full refresh), or just non-static fields in uncompressed form (dynamic refresh).

The compressor enters this state at initialisation, upon request from decompressor, or upon Refresh Time-out. The compressor leaves the IR state when it is confident that the decompressor has correctly received the refresh information.

5.1.4.2 FO State

The compressor operates in the FO state when the header stream does not conform to a uniform pattern (i.e. constant changes), or when the compressor is not confident that the decompressor has acquired the parameters of the uniform pattern. The compressor will leave this state and transition to the SO state when the header conforms to a uniform pattern and when the compressor is sufficiently confident that previous non-uniform changes have reached the decompressor.

5.1.4.3 SO State

In this state the compressor is sufficiently confident that the decompressor has also acquired the parameters of the uniform pattern. In the SO state, the compressor sends headers, which mainly consist of a sequence number. While in the SO state, the decompressor does a simple extrapolation based on information it knows about the pattern of change of the header fields and the sequence number contained in the SO header in order to regenerate the uncompressed header. The compressor leaves this state to go back to FO state when the header no longer conforms to the uniform pattern or to IR state if counter so indicates in unidirectional mode.

5.1.5 Modes and mode transitions

There are three modes of operation, each with the three states as described in 5.1.4:

- Uni-directional
- Bi-directional optimistic
- Bi-directional reliable

and the possible transitions are shown in Figure 1 below.

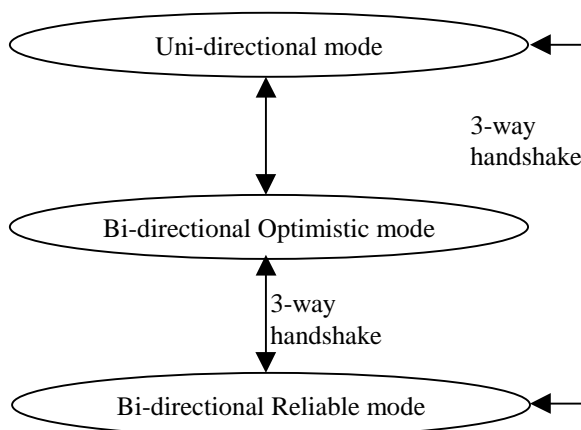

Figure 1: ROHC modes

Compression always starts in the unidirectional mode and transits to any of the bi-directional mode depending on feedback from the decompressor. The uni-directional mode implies that there is no feedback from the decompressor to the compressor while for the bi-directional optimistic there is irregular feedback and periodic feedback for the bi-directional reliable mode.

A brief description of the modes is given below:

- U-mode is used when a feedback channel is not present or undesirable to use, and it should be known that the robustness and efficiency can never be as good as with feedback (if the channel is not completely error-free).
- O-mode is aiming for highest compression efficiency while providing reasonable robustness.
- R-mode is almost completely robust but has slightly higher overhead and more feedback messages.

5.1.6 State transitions

The allowed state transitions are shown in Figure 2 and the rules and packets formats that are required are briefly described in the following subclause of this section. A more detailed description can be found in [6].

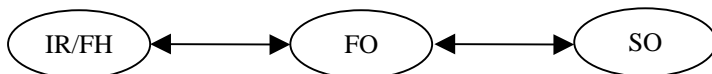

Figure 2: State transitions

5.1.6.1 Uni-directional mode

5.1.6.1.1 Compressor

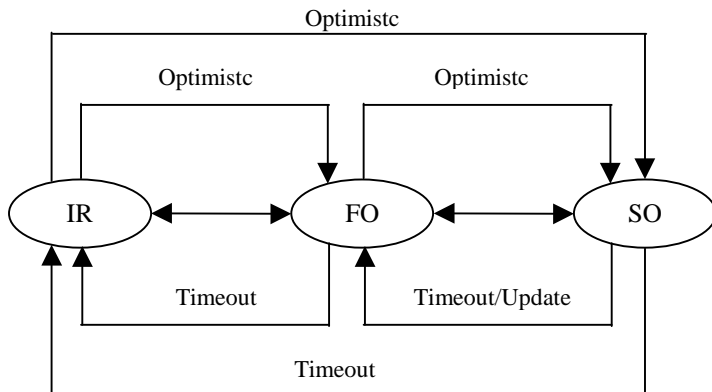

Figure 3: Uni-directional mode compressor logic

5.1.6.1.2 Decompressor

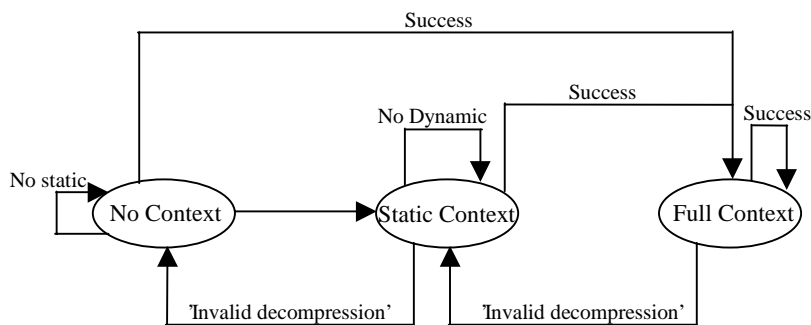

Figure 4: Uni-directional mode decompressor logic

5.1.6.2 Bi-directional optimistic

5.1.6.2.1 Compressor

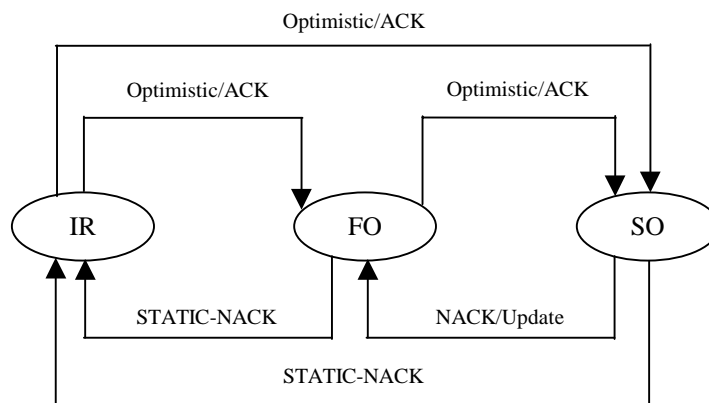

Figure 5: Optimistic mode compressor logic

5.1.6.2.2 Decompressor

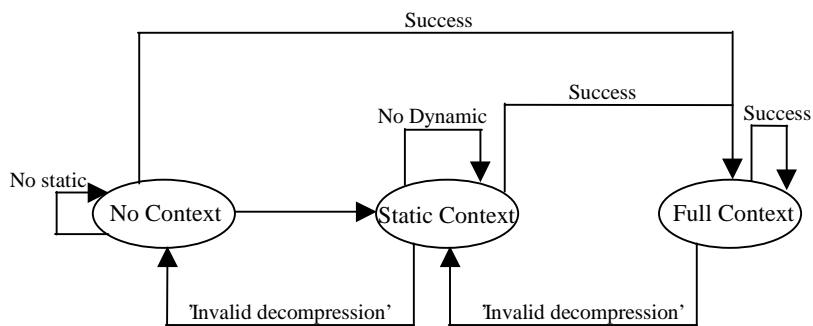

Figure 6: Bi-directional optimistic mode decompressor logic

5.1.6.3 Bi-directional reliable

5.1.6.3.1 Compressor

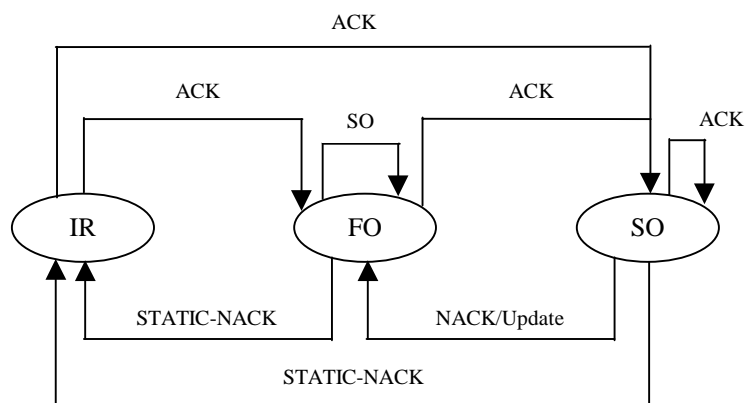

Figure 7: Reliable mode compressor logic

5.1.6.3.2 Decompressor

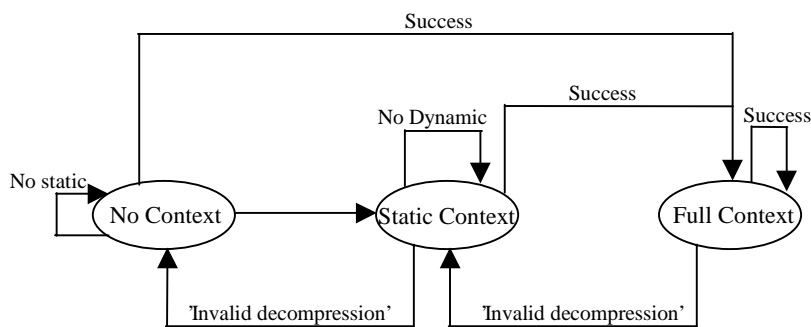

Figure 8: Reliable mode decompressor logic

5.1.6.4 Compressor and decompressor logic

It can be seen from the subclause 5.1.6 that the decompressor logic for all modes is the same as the uni-directional decompressor logic. What differs is the feedback logic, which states and what feedback messages are sent due to different events in each operating state.

5.1.7 Packet types

A ROHC RTP packet starts with a packet type identifier. The packet type indicates the format of the (first part of) packet. Packet types basically allow distinguishing between IR-DYN packets, compressed packets and feedback. Packet types can also be used to signal presence of segmented packets, padding octets, piggybacked feedback and context identifying bits in a compressed packet. As the packet type has been included in the ROHC packet it is not required to be carried by the link layer header as e.g. in RFC 2507 [10].

5.1.8 Packet formats

The ROHC protocol defines a set of packet formats. A general format for all packets is presented in Figure X below. Packet formats are organised in different categories:

- packet type 0 (UO-0, R-0, R-0-CRC);
- packet type 1 (R-mode, (R-1, R-1-TS, R-1-ID));
- packet type 1 (UO-modes, (UO-1, UO-1-ID, UO-1-TS));
- packet type 2 (UOR-2, UOR-2-ID, UOR-2-TS);
- FEEDBACK-1; and
- FEEDBACK-2.

U, O and R refer to U-mode, O-mode and R-mode, respectively. Different categories illustrate the length and the usage of the packet.

0	1	2	3	4	5	6	7	
Add-CID octet								If for CID 1-15 and small CIDs
First octet of base header								(with type indication)
0,1 or 2 octet of CID								1-2 octet is large CIDs
Reminder of base header								Variable number of bits
Extension								Extension, if X=1 in base header
IP-ID of inner IPv4 header								2 octets, if value (RND)=1
IP-ID of outer IPv4 header								2 octets, if value (RND2)=1
UDP checksum								2 octets, if context (UDP checksum)!=0
AH data for outer list								variable
AH data for inner list								variable
GRE checksum								2 octets, if GRE flag C=1

Figure 9: Packet formats from the compressor to the decompressor

5.1.9 Packet format description

This is described and specified in [6].

5.1.10 ROHC Configuration

ROHC has two kinds of parameters; configuration parameters that are mandatory and must be configured between compressor and decompressor peers, and implementation parameters that are optional and when used, mandate how a ROHC implementation operates.

Configuration parameters are mandatory and must be configured (signalled by RRC) between compressor and decompressor, so that they have the same values at compressor and decompressor. An example of a configuration parameter is context identification (CID).

Implementation parameters (ROHC primitives) make it possible to mandate how the ROHC compressor or decompressor should operate. Implementation parameters have local significance, are optional to use and are thus not necessary to be negotiated between compressor and decompressor.

This does not preclude that implementation parameters may be signalled or negotiated using lower layer functionality in order to set the way a ROHC implementation operates. Some implementation parameters are valid only at either the compressor or decompressor. Implementation parameters may further be divided into parameters that describe the way an implementation operates and into parameters that trigger a specific event, i.e., signals.

5.1.10.1 Profiles

As mentioned previously RFC 3095 [6] supports 4 different profiles. A profile describes exactly how to do compression and decompression. A profile is specific for each context and it is established with the IR header. An IR header contains a profile identifier, which determines how the rest of the header is to be interpreted. Note that the profile parameter determines the syntax and semantics of the packet type identifiers and packet types used for a specific context. Profiles have to be negotiated during link establishment. The decompressor indicates which profiles it supports and compressor may not compress using other ones. Currently, the following profiles have been defined:

- Profile 0 is for sending uncompressed IP packets.
- Profile 1 is for RTP/UDP/IP compression.
- Profile 2 is for UDP/IP compression, i.e., compression of the first 12 octets of the UDP payload is not attempted.
- Profile 3 is for ESP/IP compression, i.e., compression of the header chain up to and including the first ESP header, but not subsequent subheaders.

5.1.10.1.1 Context for Uncompressed Packets

It is possible also in the wireless environment to exceed the maximum number of supported contexts per radio bearer. Following possibilities are foreseen and have to be evaluated.

1. Only ROHC protocol used in PDCP entity. PDCP-No-Header PDU is used.
 - Different contexts are separated within ROHC protocol and CID is carried in the ROHC packet. The ROHC has its internal mechanisms to reserve one CID for sending uncompressed data over the radio link. This solution does not put any requirements on PDCP layer. All required mechanisms exist in release 99.
2. Only ROHC protocol used in PDCP entity. PDCP-Data PDU is used. This combination enables the separation of different contexts in ROHC or in PDCP.
 - If the CIDs are carried within the ROHC protocol and the case equals to point 1 above.
 - If the CIDs are carried out in PDCP. The ROHC protocol has to be configured to support only one context. The PDCP requires functionality before ROHC protocol to separate different flows and pass them through ROHC protocol. PDCP is also required to filter out data flows that exceed the maximum number of supported contexts. Such contexts should by-pass header compression and would be indicated with a dedicated CID in the PDCP header to enable bypassing the decompressor.
3. ROHC+RFC2507 protocols used in PDCP entity. As two different protocols are used it implies that PDCP-Data PDU is used.
 - This case is equal to point 2 above. A ROHC packet or PDCP header can be used to carry CID information. The CID should be carried in the PDCP headers as this utilises the one octet introduced by the PDCP header for ROHC, without having to use CID bits in the ROHC.

5.1.10.2 Context Identifier

The ROHC scheme has the possibility to support several contexts or unique IP flows. In order to track or identify these flows a Context ID (CID) is required in the ROHC packet format. This CID field is either 0 (i.e. not present), 1 or 2 octets in length. Each CID has a context and must maintain enough information in order to correctly compress and decompress these IP flows. This context will be referred to as, `CONTEXT_SIZE`. Typically, `CONTEXT_SIZE` will include at least the full/uncompressed IP header. This would be the IP/UDP/RTP header, which is 40 octets for IPv4 and 60 octets for IPv6. The `CONTEXT_SPACE` is the sum of all `CONTEXT_SIZE`s.

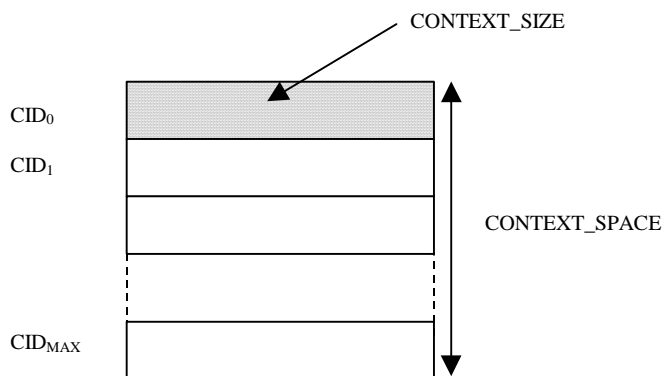

Figure 10: Header compressor contexts

The CID length of 2 octets is encoded to allow a maximum CID value of 16383 and would imply significant memory requirements. The need for such a large number of CIDs is that ROHC could be quite easily used in fixed IP backbone networks. In such cases there are several flows that a router would need to manage. This has been designed for the general case and to be future proof.

However, the requirements on the number of CIDs for each radio bearer in UTRAN pose less of a requirement and the maximum that is seen today is in the order of 5 to 15 flows per radio bearer for mobile terminals in this wireless environment.

Therefore, it is more efficient to signal the actual maximum CID value (CID_{MAX}) by RRC to the UE to configure ROHC with this value. In order for UTRAN to make a suitable choice for the maximum CID value certain capability parameters need to be indicated by the UE.

The UE, could for example indicate the CID_{MAX} in the IE "PDCP Capability". UTRAN could then configure ROHC with a maximum CID value in the range $[0, CID_{MAX}]$. This would be the simplest approach.

As explained in Section 5.1.5 of this TR, the ROHC protocol has three modes; Uni-directional (U-mode), bi-directional optimistic (O-mode) and bi-directional reliable (R-mode). Each of these modes have different requirements on the typical amount of information that is required in the stored context, with the first two modes requiring the least amount of memory resources. If the UE were to indicate the CID_{MAX} then this would have to be for the mode that required the most context space, thus providing a worst case estimate.

There are, however, several alternatives:

- I) CID_{MAX} (for all modes) is given in combination with $CONTEXT_SPACE_{MAX}$ (for all modes).
- II) CID_{MAX} is given for each mode. In addition a one bit indicator could be included in the IE "PDCP info" to indicate that the reported maximum CID is the same for all modes.
- III) $CONTEXT_SIZE_{MODE}$ is given for each MODE and a $CONTEXT_SPACE_{MAX}$ also indicated.
- IV) $CID_{MAX,1}$ is given for (U-mode and O-mode) and $CID_{MAX,2}$ is given for (R-mode). In this way there is no need for UTRAN to know the UE $CONTEXT_SPACE_{MODE}$. UTRAN can then choose a maximum CID value (Max_U_CID) between $[0, CID_{MAX,1}]$ for U-mode and O-mode and a maximum CID value (Max_R_CID) $[0, CID_{MAX,2}]$ for R-mode only. In addition a one bit indicator could be included in the IE "PDCP info" to indicate that the reported maximum CID is the same for all modes.

It is recommended that alternative II is chosen. Therefore Max_U_CID , Max_O_CID and Max_R_CID is indicated in the RRC IE "PDCP Capability". However, it has to be evaluated what effect different CID sizes for different modes have on the ROHC protocol. As the decompressor makes the decision of the mode changes, different CIDs in different modes will have an effect on the mode change criteria.

5.1.10.3 0-octet-CID

In subclause 5.1.10.2 it was stated that the CID field in the ROHC packet format could be 0, 1 or 2 octets in length. Large CID spaces are not typically required for terminals in the wireless scenario.

It is possible to include the CID value on the PDCP layer instead of ROHC headers. In 3GPP Release 99, the PDCP layer can be configured to introduce a PDCP header or not to introduce a PDCP header. The PDCP header is typically required for HC protocols that require link layer (i.e. the layer that 'carries' HC) identification of the HC packet types.

3GPP Release 99 includes only one HC protocol (RF2507) and this requires link level identification of the HC packet formats. Header compression protocols that do not require link layer identification do not require PDCP to include a PDCP header. ROHC is one such protocol. PDCP configured to support only ROHC would typically be configured not to introduce a PDCP header.

With the introduction of an additional HC protocol to the suite of HC protocols to be used in UTRAN it is currently not possible to configure PDCP entity to accommodate HC protocols that do and do not require link layer packet identification (or any other header compression information).

It is important that the HC algorithms that will be included in Release 4 can be used on the same PDCP entity. RFC2507 can compress UDP/IP and/or TCP/IP streams while the current ROHC profile can compress RTP/UDP/IP, UPD/IP and ESP/IP streams. It is quite typical that different types of IP streams will be mixed together, for example in streaming applications.

There are two ways that this can be achieved and these are discussed below:

- Introducing a new PDCP PDU type for ROHC packets
- Using the same PDCP PDU type for ROHC and RFC2507

5.1.10.3.1 Introducing a new PDU Type for ROHC packets

The PDCP data PDU is shown below in Table 1. This PDCP header is 1 octet and consists of 2 fields; the PDU type field (3 bits) and the PID field (5 bits).

Table 1: PDCP-Data-PDU format

PDU type	PID
Data	

The PDU Type field in the PDCP PDU header indicates the type of PDCP data PDU and is shown below in Table 2. The PID field identifies the exact header compression packet type and the setting of the PID values is described in TS 25.323.

Table 2: PDCP-Data-PDU format

Bit	PDU Type
000	PID field used for header compression information (PDCP-PDU format described in table 5)
001	PID field used for header compression information and the PDCP PDU sequence number included (PDCP-PDU format described in table 6)
010	ROHC CID packet (PDCP-PDU).
011-111	Reserved (PDUs with this encoding are invalid for this version of the protocol)

In order to mix RFC2507 and ROHC there needs to be a header in PDCP as RFC2507 requires link level identification of the HC packet formats. It is only a matter of introducing a PDU type (010: ROHC CID packet) for ROHC packets to allow the possibility to mix RFC2507 and ROHC. The PID field for this PDCP Type (010: ROHC CID packet) would be defined for use as CID identification. The benefit here is that 32 CIDs can be identified and that the ROHC packet format would operate without a CID i.e. in 0-octet-CID mode, thereby saving, at best 2 octets overhead. Therefore, the PDCP PDU format would be as described in Table 3.

Table 3: PDCP-Data-PDU format

PDU type (010)	CID
Data	

The data part as indicated in Table 3 would be the ROHC packet when ROHC would be configured to have $CID_{MAX} = 1$ context (it will ensure that the CID field is not present in the ROHC packet).

If the number of CIDs is greater than what can be accommodated in the PID field (referred as CID field in table y) of the PDCP PDU header then the CID of 1 or 2 octets in the ROHC packet is/are used. The PID field is therefore unused in this case.

5.1.10.3.2 Using the same PDCP PDU type for ROHC and RFC2507

In this case ROHC and RFC2507 protocols are identified by the same PDU Type = '000' but the packet formats for these protocols are distinguished by the 5 bit PID field in the PDCP Data PDU. For RFC2507, the PID values identify the packet formats and for ROHC the PID values are used to identify the CONTEXT ID for the flow. The maximum number of CIDs that can be accommodated in the 5-bit CID/PID field is dependent on the number of PID values that are used for identification of packet types for other header compression protocols. The PID field is not used to identify the ROHC packet formats as this is done within the ROHC

If ROHC is the only protocol that is configured then up to 32 CIDs could be identified. The variables Max_U_CID , Max_O_CID and Max_R_CID are configured by the RRC protocol during configuration or reconfiguration of the header compression protocol. Refer to Alternative II, in Section 5.1.10.1 above.

The assignment of PIDs for CIDs is shown in Table 4 below.

Table 4: PID values assigned to ROHC header compression protocol

PID value	Optimisation method	Packet type
N+1	ROHC	CID1
N+2	ROHC	CID2
...	ROHC	...
...	ROHC	...
N+n	ROHC	CID _n

If the number of CIDs is greater than what can be accommodated in the PID field of the PDCP PDU header then the CID of 1 or 2 octets in the ROHC packet is used and the PID field is therefore unused in this case.

The 0-octet-CID option is the recommended CID configuration for ROHC in UTRAN.

5.1.10.4 Segmentation

ROHC protocol supports segmentation. The segmentation can vary packet by packet and it does not cause any overhead to packets that are not segmented. The segmentation may not be used when ROHC is run on top of UM RLC and then MRRU (maximum reconstructed reception unit) shall be equal to 0. The only case when the usage of ROHC segmentation is allowed is when ROHC is run on top of Tr RLC and the Packet_Sizes_Allowed is used to configure ROHC packet sizes. Furthermore, in that case segmentation may only be applied if the produced packet does not fit to the largest packet indicated by Packet_Sizes_Allowed.

5.1.10.5 Packet_Sizes_Allowed

This is a list of positive integer values which mandate the packet sizes that are allowed to be produced by ROHC. If this parameter list is set it has to contain packet size that allows a transmission of an entire IR header. Otherwise ROHC segmentation has to be used. It is also recommended to use packet sizes that are most frequently used in SO and FO states. If segmentation is not allowed/configured, then one of the Packet sizes allowed must accommodate the largest ROHC packet size possible which typically is the IR packet. NOTE: ROHC has an in-built segmentation functionality which takes place when the packets do not fit to the defined packet size. Therefore, extra attention has to be paid if the header sizes will be defined e.g. by RRC so that reasonable values are selected. Otherwise, segmentation will be performed in ROHC and possibly in RLC. However, it has to be noted that ROHC segmentation does not add any overhead to the packets that are not segmented (that should be the case in UTRAN).

5.1.10.6 Feedback

Feedback from decompressor to the compressor can be realised in several ways.

- 1) Feedback is provided as in release 99 when the feedback packets are transmitted with data packets on the same logical channel. This is same as the RLC AM model of operation for control and data RLC PDUs.
- 2) Another RLC link could be set up under one PDCP entity which would be used as a dedicated feedback-only link.
- 3) The feedback packets are piggybacked to the compressed packets in the compressor. This option will require also mechanism 1 or 2 if the traffic to opposite direction does not exist or is very infrequent.

The recommended method of providing feedback is as in option 1) above.

5.1.10.7 Example PDCP Configuration

```
CHOICE Algorithm type: RFC2507 and ROHC
PDCP_Header          Present          PDCP will introduce a 1 octet header (PDU Type = 000 or 010)
RFC2507
...
ROHC
  MAX_CID              10              Maximum CID value for ROHC
  PROFILES_SUPPORTED  0,
                    1,              Uncompressed IP
                    2,              RTP/UDP/IP
                    3              UDP/IP
  PACKET_SIZES_ALLOWED 1, 2, 6, 28, 40 ESP/IP
  REVERSE_DECOMPRESSION_DEPTH 0      In octets
                                       No reverse decompression
```

5.1.11 ROHC primitives and parameters

5.1.11.1 ROHC Primitives at the compressor

5.1.11.1.1 CONTEXT_REINITIALIZATION

The parameter triggers the initialisation of static and dynamic parts of the context at the decompressor. In this state, the compressor sends complete header information. This includes all static and non-static fields in uncompressed form plus some additional information. When triggered the compressor shall reinitialise all contexts.

5.1.11.2 ROHC Primitives at the decompressor

5.1.11.2.1 MODE

This parameter triggers a mode transition using the mechanism described in ROHC protocol specification [6]. The possible parameter values are U, O and R and correspond to the U-mode, O-mode and R-mode, respectively.

The mode transition is made from the current mode to the new mode as signalled in the MODE primitive. MODE should not only serve as a trigger for mode transitions, but to also make it visible which mode ROHC operates in.

5.1.11.2.2 CLOCK_RESOLUTION

This parameter indicates the resolution of the system clock. A zero value will indicate that system clock is not available and thus timer based TS compression nor SN wrap-around detection are not possible.

5.1.11.2.3 Reverse_decompression_DEPTH

The parameter indicates whether reverse decompression is performed and to what extent. Value 0 indicates that reverse decompression shall not be performed.

5.1.11.3 Summary of ROHC Parameters

A ROHC implementation may have two kinds of parameters: configuration parameters that are mandatory and must be negotiated between compressor and decompressor peers, and implementation parameters that are optional and, when used, stipulate how a ROHC implementation is to operate.

Configuration parameters are mandatory and must be configured between compressor and decompressor, so that they have the same values at both compressor and decompressor.

Implementation parameters make it possible for an external entity to stipulate how an implementation of a ROHC compressor or decompressor should operate. Implementation parameters have local significance, are optional to use and are thus not necessary to negotiate between compressor and decompressor. As such, this does not affect the interoperability between ROHC implementations.

Some implementation parameters are valid only at either of compressor or decompressor. Implementation parameters may further be divided into parameters that allow an external entity to describe the way the implementation should operate and parameters that allow an external entity to trigger a specific event, i.e., signals.

The parameters in subclause 5.1.11.3.1 and 5.1.11.3.2 are classified in the following way:

M: Mandatory and configured by upper layers.

MO: Parameters that must be supported and when used can only be configured or triggered by upper layers.

O: Optional ROHC parameters that are not configured by upper layers. They may be used locally (i.e. UTRAN and/or in UE) for the ROHC implementation.

N/A: These are not used in the ROHC implementation/configuration.

The usage and definition of the parameters below are specified in [6].

5.1.11.3.1 Configuration Parameters

- MAX_CID (M)
- LARGE_CIDS: This is not configured by upper layers but inferred from the configured value of MAX_CID according to the following rule:

If MAX_CID > 15 then LARGE_CIDS = TRUE else LARGE_CIDS = FALSE.

- PROFILES (M): Profiles are used to define which profiles are allowed to be used by the UE in uplink. All profiles defined in [6] shall be supported by UE.
- FEEDBACK_FOR (N/A):
- MRRU (M): Segmentation is not used by default.

5.1.11.3.2 Implementation Parameters

5.1.11.3.2.1 Compressor

Operational

(PDCP → ROHC):

- NO_OF_PACKET_SIZES_ALLOWED (O)
- PACKET_SIZES_ALLOWED (MO): When this option is used then no others packet sizes are allowed to be used.
- PAYLOAD_SIZES (O)

(ROHC → PDCP):

- NO_OF_PACKET_SIZES_USED (O)
- PACKET_SIZES_USED (O)

Event Triggers

- CONTEXT_REINITIALIZATION (MO)

5.1.11.3.2.2 Decompressor

Operational

(PDCP→ROHC):

- MODE (O)
- CLOCK_RESOLUTION (O)
- REVERSE_DECOMPRESSION_DEPTH (M): Default value is that reverse decompression is not used.

(ROHC→PDCP):

- None.

Event Triggers

- None.

5.1.13 ROHC Reconfiguration

ROHC is reconfigured in the same way as PDCP in Release 99, by the RRC RADIO BEARER RECONFIGURATION message [3].

5.1.14 ROHC with SRNS relocation

As ROHC is part of the PDCP layer, there is a compressor and decompressor pair in the RNC and a corresponding compressor and decompressor pair in the UE. During SRNS relocation the source RNC gives the role of the serving RNC (SRNC) to the target RNC. This is described in TS 23.060 [11] and in TS 25.303 [12].

The impact of SRNS relocation on header compression is only on the state of the context information. It needs to be defined how the contexts are handled as a result of the relocation. Two methods exist for when the target RNC supports RFC 3095:

- 1) No transfer of context information from source RNC to target RNC
- 2) Transfer of context information from source RNC to target RNC

On the selection of the two methods, as stated above, the following have to be considered:

- No context transfer will cause additional overhead to the radio interface after relocation, as the contexts have to be initialised in UE and in UTRAN. This may cause e.g. speech quality degradation as the header parts may steal resources from the payload.
- Context transfer option does not cause any additional overhead to the radio interface. However, The Iur is more loaded as the contexts have to be transferred over that. Furthermore, the compressor/decompressor relocation will cause a break to real time traffic.

In the selection of the method of handling contexts during relocation, the main selection criteria should be to minimise degradation of traffic quality during relocation. Other criteria may be complexity and overhead in radio and Iur interface.

For when the target RNC does not support RFC 3095 is FFS.

5.1.14.1 No context transfer

Immediately after relocation, the compressor in the UE and the target RNC must switch to the IR (Initialisation state) in U-mode. The ROHC CONTEXT_REINITIALIZATION primitive as described in Section 5.1.11.1.1 is used for this purpose.

PDCP uses the IR state trigger:

- after sending the CPDCP-RELOC-Conf in the UE
- after receiving the CPDCP-SN-Req in the target RNC

This is shown in Figure 11, which is a simplified version of the combined Cell/URA update with SRNS relocation example as shown in [12]. Similarly, Figure 12 shows the simplified version of the Hard Handover with SRNS relocation as shown in [12]. The benefit of this approach is that there is no impact on RAN WG3 specifications. However, this scheme will temporarily add overhead to the radio interface and degrade e.g. voice quality as the initialisation of contexts is being performed and so full headers are sent in form of static and dynamic parts.

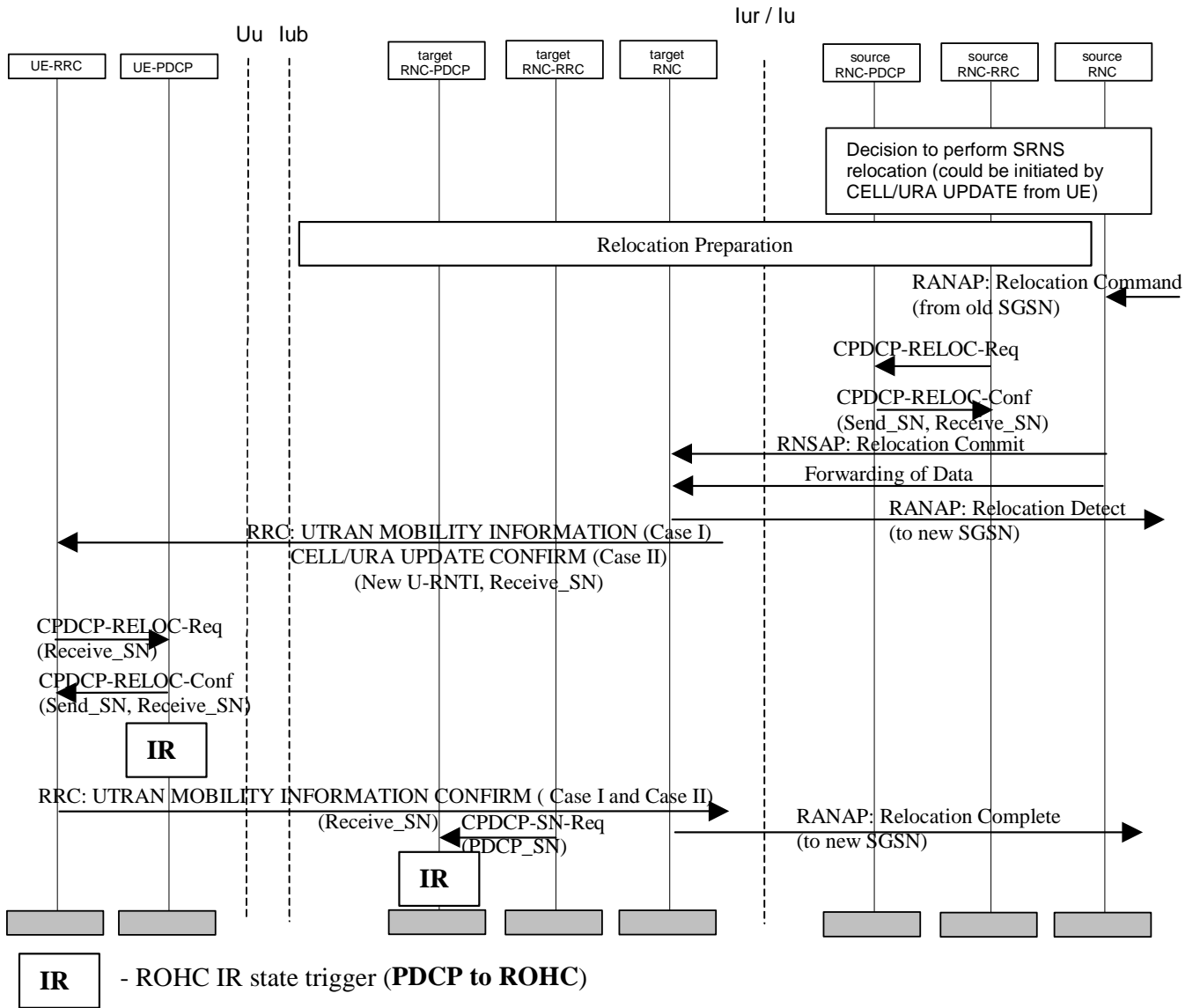

Figure 11: ROHC handling during SRNS relocation

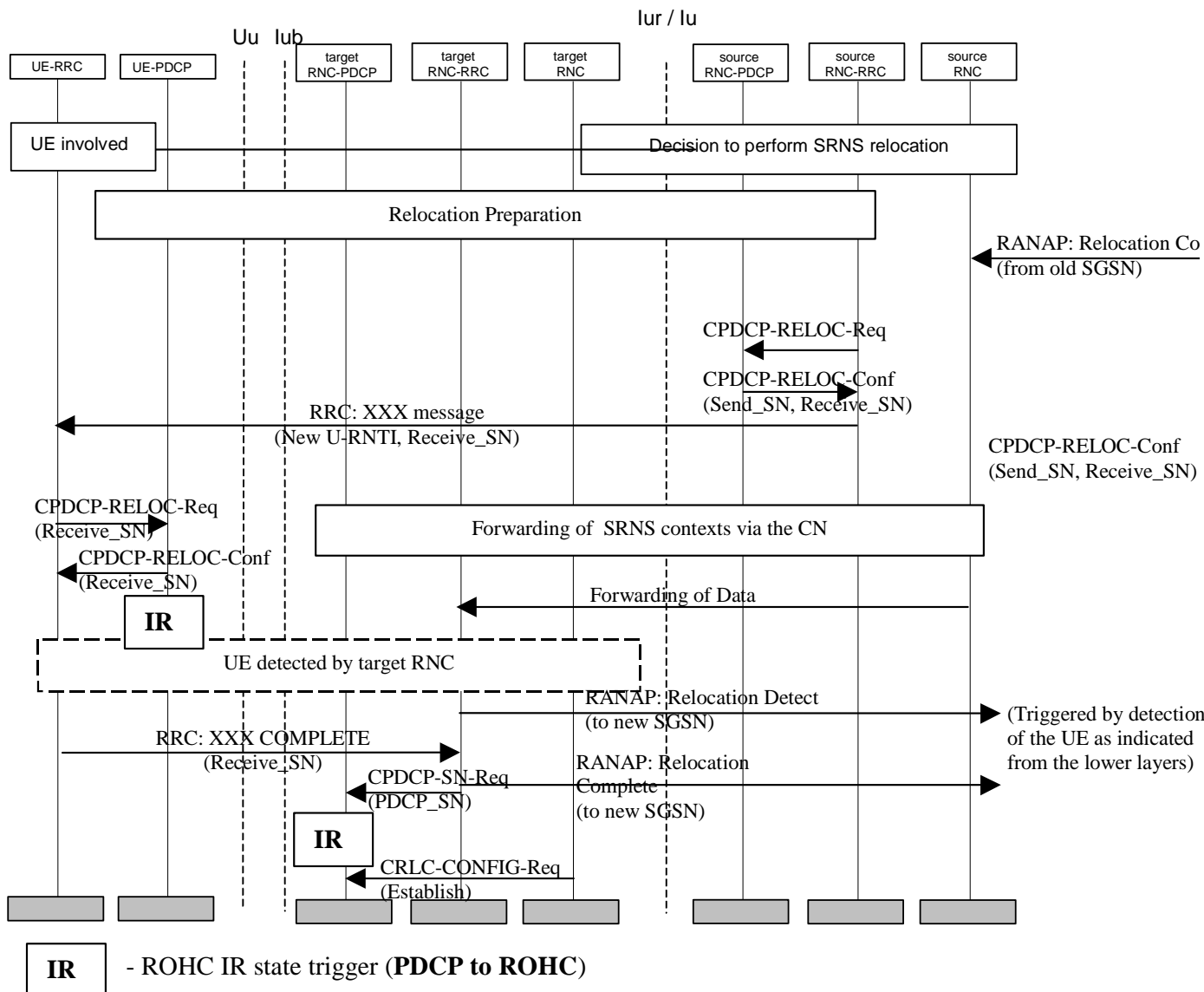

Figure 12: ROHC handling during Hard Handover with SRNS relocation

5.1.14.2 Context transfer

The simplest way to implement context relocation is to stop compression in UE and UTRAN before relocation happens. This will, however, add significant break to real time connection which may not be acceptable. Unless the compression is stopped the implications should be further studied.

5.2 PDCP multiplexing

No input has been made to this part of the work item and thus it will not be completed for Release 4. The applicability of PDCP multiplexing in later releases is FFS.

5.3 Variable Iu frame formats and unequal error protection

The work on this item should be done in 3GPP TSG RAN WG3. No input has been made to this part of the work item and thus it will not be completed for Release 4. The applicability of Variable Iu frame formats and unequal error protection in later releases is FFS.

5.4 Channel type switching per logical channel

No input has been made to this part of the work item and thus it will not be completed for Release 4. The applicability of Channel type switching per logical channel in later releases is FFS.

5.5 Header removal

The technique of IP header removal is developed under the responsibility of TSG GERAN.

To increase efficiency for Radio Bearers carrying real-time packet switched data, especially Voice Over IP streams using RTP/UDP/IP, the data packets arriving to the AS may be modified in PDCP to remove RTP/UDP/IP header information. Only the IP-packet's payload is then submitted to RLC in the PDCP-No-header PDU.

This IP header removal is only used for optimised speech applications. It is developed to be used in GERAN and its applicability for UTRAN is FFS.

The (re-)generation of RTP/UDP/IP headers at the UE is optional but mandatory in RAN.

No further input has been made to this part of the work item. This work is intended to be completed by TSG GERAN.

6 Impacts on RAN WGs

This chapter reviews the impacts on other RAN WGs in relation to the study areas as outlined in the Scope chapter of the Technical Report for the Release 4 work item, "Radio Access Bearer Support Enhancements".

Where a study area has been recommended as not for Release 4 (refer to Chapter 7), the impacts to the other RAN WGs are indicated as "Not applicable for Release 4".

6.1 WG1

6.1.1 Robust header compression

None.

6.1.2 PDCP multiplexing

Not applicable for Release 4.

6.1.3 Variable Iu frame formats and unequal error protection over Uu

Not applicable for Release 4.

6.1.4 Channel type switching per logical channel

Not applicable for Release 4.

6.1.5 Header removal

This work is intended to be completed by TSG GERAN. Not applicable for Release 4.

6.2 WG2

6.2.1 Robust Header Compression

The 3GPP TSG RAN WG2 specifications that are affected are described in the following subclauses:

6.2.1.1 Radio Resource Control 25.331

RRC messages need to be updated to include the RFC 3095 option as another supported header compression protocol choice. Updates are required in the IE "PDCP info".

Also the respective ROHC related parameters need to be included in the IE "PDCP info". These are:

- Max_CID
- Supported ROHC Profiles
- MRRU
- Packet_Sizes_Allowed
- Packet size
- Clock_Resolution
- Reverse-Decompression_Depth

The IE "PDCP Capability" needs to be updated to indicate whether RFC 3095 is supported in the user equipment.

6.2.1.2 Packet Data Convergence Protocol 25.323

RFC 3095 is included as another header compression protocol. The RFC 3095 protocol is introduced by the "Assignment of PID values for RFC 3095 with CIDs in PDCP PDU Header", as described in 5.1.10.3.2 in the technical report.

6.2.1.3 UE Radio Access Capabilities TS 25.306

The RFC 3095 protocol needs included as a capability. The parameters included in IE "PDCP Capability" are reflected in this technical specification.

6.2.2 PDCP multiplexing

Not applicable for Release 4.

6.2.3 Variable lu frame formats and unequal error protection overUu

Not applicable for Release 4,

6.2.4 Channel type switching per logical channel

Not applicable for Release 4.

6.2.5 Header removal

This work is intended to be completed by TSG GERAN. Not applicable for Release 4.

6.3 WG3

6.3.1 Robust header compression

The relocation of the header compression contexts is FFS in Release 5 and therefore the introduction of ROHC does not have impact to RAN WG3.

6.3.2 PDCP multiplexing

Not applicable for Release 4.

6.3.3 Variable lu frame formats and unequal error protection overUu

Not applicable for Release 4,

6.3.4 Channel type switching per logical channel

Not applicable for Release 4.

6.3.5 Header removal

This work is intended to be completed by TSG GERAN. Not applicable for Release 4.

6.4 WG4

6.4.1 Robust header compression

None.

6.4.2 PDCP multiplexing

Not applicable for Release 4.

6.4.3 Variable lu frame formats and unequal error protection overUu

Not applicable for Release 4.

6.4.4 Channel type switching per logical channel

Not applicable for Release 4.

6.4.5 Header removal

This work is intended to be completed by TSG GERAN. Not applicable for Release 4.

7 Recommendations

7.1 Robust header compression

The Robust Header compression protocol (RFC 3095) is included as another supported protocol in Release 4 of PDCP and introduced into Release 4 as outlined in section 6.2.1 of this technical report.

7.2 PDCP multiplexing

Not for Release 4.

7.3 Variable lu frame formats and unequal error protection over Uu

Not for Release 4.

7.4 Channel type switching per logical channel

Not for Release 4.

7.5 Header removal

This work is intended to be completed by TSG GERAN. Not applicable for Release 4.

8 Release 99 Specification Impacts

No impacts to Release 99 specifications.

Annex A: Change history

Change history							
Date	TSG #	TSG Doc.	CR	Rev	Subject/Comment	Old	New
03/2001	RP-11	RP-010048	-		TO BE Approved at TSG-RAN #11 and placed under Change Control	-	3.0.0