

Presentation of Specification to TSG or WG

Presentation to: TSG-RAN Meeting #11

Document for presentation: TR 25.847 Version 2.0.0

Presented for: Approval

Abstract of document:

This technical report captures the results of the work on the work item “UE positioning enhancements”. For Release 4 only the OTDOA enhancement for TDD using IPDLs was agreed. The impacts on layer 1 and UTRAN interfaces are described and the affected specifications are listed.

Additionally contributions for the following methods were presented which will be discussed for Release 5:

- Almanac based Differential GPS
- OTDOA enhancement using Positioning Elements (PE)

The description of the positioning methods “Angle of Arrival”, “Observed Time Of Arrival” and “Reference Node Based Positioning” was moved from TS 25.305 to the TR in order to prevent loss of already existing descriptions, but there were no contributions regarding these methods.

Changes since last presentation to TSG-RAN Meeting:

Section 4 of the TR was restructured to reflect the decisions about which methods to include for release 4.

The following sections were added:

- section 5.1.4 on IPDL impact on the power control.
- Section 5.2 on OTDOA-PE impact on layer 1.
- Sections 6.1 and 6.2 on IPDLs for TDD and OTDOA-PE impact on the UTRAN interfaces
- Section 7.1 on impacted specifications by introducing IPDLs for TDD

Besides, minor changes to section 5.1.2 and 5.1.3 were done and additional descriptive text of the OTDOA-PE method was added in section 4.

Outstanding Issues:

There are no outstanding issues for Release 4.

Contentious Issues:

3GPP TR 25.847 V2.0.0 (2001-03)

Technical Report

3rd Generation Partnership Project; Technical Specification Group Radio Access Network; UE positioning enhancements (Release 4)



The present document has been developed within the 3rd Generation Partnership Project (3GPP™) and may be further elaborated for the purposes of 3GPP.

The present document has not been subject to any approval process by the 3GPP Organisational Partners and shall not be implemented. This Specification is provided for future development work within 3GPP only. The Organisational Partners accept no liability for any use of this Specification. Specifications and reports for implementation of the 3GPP™ system should be obtained via the 3GPP Organisational Partners' Publications Offices.

Keywords

<keyword[, keyword]>

3GPP

Postal address

3GPP support office address

650 Route des Lucioles - Sophia Antipolis
Valbonne - FRANCE
Tel.: +33 4 92 94 42 00 Fax: +33 4 93 65 47 16

Internet

<http://www.3gpp.org>

Copyright Notification

No part may be reproduced except as authorized by written permission.
The copyright and the foregoing restriction extend to reproduction in all media.

© 2000, 3GPP Organizational Partners (ARIB, CWTS, ETSI, T1, TTA, TTC).
All rights reserved.

Contents

| | |
|--|----|
| Foreword..... | 5 |
| 1 Scope | 6 |
| 2 References | 6 |
| 3 Abbreviations | 6 |
| 3.1 Abbreviations | 6 |
| 4 Main concepts..... | 6 |
| 4.1 Assumptions..... | 6 |
| 4.2 Location Services Categories | 7 |
| 4.3 UE positioning methods in Release 4..... | 7 |
| 4.3.1 Release 4 Enhancements for Release 99 Standard UE positioning Methods..... | 7 |
| 4.3.1.1 OTDOA location method in TDD | 7 |
| 4.3.1.1.1 Use of Idle Periods..... | 7 |
| 4.4 UE positioning methods not for Release 4..... | 7 |
| 4.4.1 Angle of Arrival (AOA) | 7 |
| 4.4.2 Observed Time of Arrival (OTOA)..... | 7 |
| 4.4.3 Reference Node-Based Positioning (OTDOA-RNBP)..... | 8 |
| 4.4.4 OTDOA - Positioning Elements (OTDOA-PE) | 8 |
| 4.4.4.1 Introduction | 8 |
| 4.4.4.2 PE positioning procedure overview..... | 8 |
| 4.4.4.3 Improvement on OTDOA-IPDL..... | 10 |
| 4.4.4.4 UTRAN UE positioning architecture | 11 |
| 4.4.4.4.1 Positioning Elements (PEs)..... | 11 |
| 4.4.4.5 Signalling protocols and interfaces..... | 11 |
| 4.4.4.5.1 Signalling between RNC and PEs..... | 11 |
| 4.4.4.6 General UTRAN UE positioning procedures | 11 |
| 4.4.4.6.1 PE Functions | 11 |
| 4.4.4.6.2 SRNC-PE Interactions | 12 |
| 4.4.4.6.3 SRNC-UE interactions..... | 12 |
| 4.4.4.7 OTDOA-PE positioning method | 12 |
| 4.4.4.7.1 System modes | 12 |
| 4.4.4.7.2 UE modes..... | 12 |
| 4.4.4.7.3 PE modes | 12 |
| 4.4.4.7.4 Information to be transferred between UTRAN elements | 12 |
| 4.4.4.7.5 OTDOA-PE network positioning procedures | 13 |
| 4.4.5 Almanac-based DGPS method (DGPS-A) | 13 |
| 5 Layer 1 impacts | 14 |
| 5.1 OTDOA location method in TDD..... | 14 |
| 5.1.1 Impacts of Idle Periods..... | 14 |
| 5.1.1.1 General | 14 |
| 5.1.2 Parameters of IPDL | 15 |
| 5.1.3 Calculation of idle period position | 15 |
| 5.1.4 Impact on the Open Loop Power Control..... | 16 |
| 5.2 OTDOA-PE method..... | 16 |
| 5.2.1 PE impact | 16 |
| 5.2.1.1 UE complexity..... | 16 |
| 5.2.1.2 UE cell search/synchronisation | 17 |
| 5.2.1.3 PE complexity | 17 |
| 5.2.1.4 Capacity issues | 17 |
| 6 Impacts on UTRAN interfaces | 17 |
| 6.1 OTDOA location method..... | 17 |
| 6.1.1 Impacts of IPDLs in TDD | 17 |
| 6.2 OTDOA-PE method..... | 17 |
| 6.2.1 PE impact on network | 17 |

7 Specification Impacts 18
7.1 OTDOA IPDLs for TDD.....18
Annex A: Change history 19

Foreword

This Technical Specification has been produced by the 3rd Generation Partnership Project (3GPP).

The contents of the present document are subject to continuing work within the TSG and may change following formal TSG approval. Should the TSG modify the contents of the present document, it will be re-released by the TSG with an identifying change of release date and an increase in version number as follows:

Version x.y.z

where:

- x the first digit:
 - 1 presented to TSG for information;
 - 2 presented to TSG for approval;
 - 3 or greater indicates TSG approved document under change control.
- y the second digit is incremented for all changes of substance, i.e. technical enhancements, corrections, updates, etc.
- z the third digit is incremented when editorial only changes have been incorporated in the document.

1 Scope

This technical report identifies possible UE positioning enhancements and new methods for UTRA TDD and FDD for Release 4. It shall build the basis for evaluation and comparison of these methods and enhancements. The report also covers the impacts on Layer1 and UTRAN interfaces.

Finally, CRs to the affected specifications should be created based on this TR.

2 References

The following documents contain provisions which, through reference in this text, constitute provisions of the present document.

- References are either specific (identified by date of publication, edition number, version number, etc.) or non-specific.
- For a specific reference, subsequent revisions do not apply.
- For a non-specific reference, the latest version applies. In the case of a reference to a 3GPP document (including a GSM document), a non-specific reference implicitly refers to the latest version of that document *in the same Release as the present document*.

- [1] 3GPP°TS°25.305: "Stage 2 Functional Specification of Location Services".
- [2] 3GPP°TS°25.225: "Physical Layer, Measurements (TDD)".
- [3] 3GPP°TS°25.224: "Physical Layer Procedures (TDD)".
- [4] 3GPP°TS°25.331: "RRC Protocol Specification".

3 Abbreviations

3.1 Abbreviations

For the purposes of the present document, the following abbreviations apply:

| | |
|-------|-------------------------------------|
| BCH | Broadcast Channel |
| DGPS | Differential GPS |
| GPS | Global Positioning System |
| OTDOA | Observed Time Difference Of Arrival |
| PSCH | Primary Synchronisation Channel |
| UE | User Equipment |
| SCH | Synchronisation Channel |
| TDD | Time Division Duplex |

4 Main concepts

The main concepts are the same as specified in [1].

4.1 Assumptions

The location services categories are the same as specified in [1].

4.2 Location Services Categories

Location Services in Release 4 shall be based on the same principles as apply for Release '99. Signal measurements made by the UE, Node B or auxiliary measurement units such as Location Measurement Units (LMUs) are used for location estimation. The location estimation is calculated by a position calculation function in the UE or in the UTRAN.

4.3 UE positioning methods in Release 4

4.3.1 Release 4 Enhancements for Release '99 Standard UE positioning Methods

4.3.1.1 OTDOA location method in TDD

The OTDOA method is described in [1]. Basically this method is also already available in Release '99 for TDD since OTDOA is based on the SFN-SFN observed time difference type 2 measurement, which is specified in [2]. For TDD it is not specified on which physical channel to perform the measurement. Therefore a UE may make measurements in every slot within a frame. Because of having synchronised cells, a relative time difference between neighbouring cells is not needed for the position estimation.

However, in some conditions a sufficient number of cells may not be available for measurements at the UE. In order to increase the probability to receive signals from neighbouring cells, IPDLs may be applied.

4.3.1.1.1 Use of Idle Periods

Because of traffic in the serving cell as well as in neighbouring cells and multipath propagation, the UE might be unable to detect a sufficient number of neighbouring cells. This is known as the hearability problem. Therefore, probably only UEs that are located on the edge of a cell are able to determine their location by using the OTDOA method.

To overcome the hearability problem, an idle period method may be used. In this method each base station ceases its transmission for short periods of time (idle periods). During an idle period of a base station, terminals within the cell can measure other base stations and the hearability problem is reduced.

The idle periods in TDD are realised by ceasing the transmission within a whole slot. The timing of the idle period occurrences is signalled to the UE via RRC signalling, so that the UEs know when to expect the idle period. The operation and specification of the idle periods for TDD can be found in clause 5.

4.4 UE positioning methods not for Release 4

4.4.1 Angle of Arrival (AOA)

The location method may make use of the angle of arrival of the radio signals to estimate the UE location. This technique may, for example, make use of the sector of the base station used for receiving or transmitting to establish the location region and to assist to resolve ambiguity in other techniques. Some other techniques may make use of narrow beam antennas to resolve the direction between the UE and the base station to a very small angle.

The AOA techniques and the signalling required for their support, are FFS.

4.4.2 Observed Time of Arrival (OTOA)

The location service technique may make use of measurements of the time of arrival of signals. A UE, for example, which has available a suitable reference time, may measure the time of arrival of signals from the base stations and other sources. Some of these may include reference signals from satellites. The time-of-arrival may be used to estimate the distance from the source and hence derive a location estimate.

The OTOA technique may also be used to measure signals transmitted by the UE. Base stations which are able to receive signals from the UE, and which share a suitable reference time, may each measure the time of arrival of signals

from the UE. These times-of-arrival may be used to estimate the distance to the UE and hence derive a location estimate.

The OTOA techniques and the signalling required for their support, are FFS.

4.4.3 Reference Node-Based Positioning (OTDOA-RNBP)

The RNBP method is based on the OTDOA. The main principle of the RNBP method is that it chooses a reference node for providing auxiliary measurements for its location calculation. The reference node may be a mobile equipped by a GPS receiver that provides its co-ordinates, a fixed or movable LCS service provider equipment, a mobile capable of using cellular relay technique (e.g. located at the soft handover area).

RNPB can also be utilised with other methods. It is especially useful in case of NLOS from/to the required number of neighbouring base stations. This may occur when the UE is located at the area where it may suffer from the hearability effect. Additionally it can support the LCS even in case UTRAN is not equipped by IPDL like mechanism to combat the hearability effect.

4.4.4 OTDOA - Positioning Elements (OTDOA-PE)

4.4.4.1 Introduction

The Observed Time Difference Of Arrival utilising Positioning Elements (OTDOA-PE) method is an enhancement to the standard OTDOA method whereby the User Equipment (UE) makes measurements on radio signals transmitted from a number of handset sized positioning elements (PEs) located at reference points other than the Node Bs. The measurements are the same as those made in the standard OTDOA and OTDOA-IPDL UE positioning methods. The PEs transmit identifier codes of very short duration (e.g., 3 symbols with each symbol of length 256 chips) in the downlink at known times with regard to the timing of the serving cell Node B.

The provision of these additional reference points for OTDOA measurements leads to a significant increase in positioning accuracy over the Node B based OTDOA UE positioning method. It also facilitates UE positioning services in areas where measurement of other reference points (neighbouring Node Bs and/or satellites) may be problematic.

OTDOA measurements on PE signals can be used to complement the OTDOA-IPDL measurements or – if a sufficient number of PEs have been installed – used as standalone measurements to derive UE positioning estimates. The OTDOA-PE UE positioning enhancement will be optional leaving it open for an operator to:

- (i) ignore this capability;
- (ii) install a few PEs in order to achieve positioning where it is not possible with other methods (e.g., edge of coverage, in buildings etc.);
- (iii) install a significant number of PEs in order to achieve higher accuracy throughout the system.

4.4.4.2 PE positioning procedure overview

The basic role of the PEs is to transmit identifier codes in the downlink at known times with regard to the timing of a serving cell Node B. At power-on, a PE follows the same 3 step cell search procedure conducted by UEs (P-SCH slot synchronisation, S-SCH frame synchronisation and code group identification and finally CPICH scrambling code identification) to synchronise with the serving Node B. Upon completion of these three steps, the PE, just like any UE, is able to decode necessary broadcast information on the P-CCPCH channel enabling it to read system information, register with the network and start monitoring the paging channel.

The network may then page the PE and signal the initial configuration parameters requesting the PE to either remain silent, transmit continuously or transmit in bursts. The parameters signalled by the network via an RRC message are transmit power, identifier code, associated Node B and parameters for transmit period determination. The PE transmission periods are calculated in the manner of idle periods (IPDL) allowing transmissions to be in continuous or burst modes. Further update of configuration parameters may be performed by the network in response to long term variations in traffic loads, failures of some PEs or introduction of more PEs in a cell, etc.

Each PE transmits its identifier code at predetermined instances (defined by IPDL parameters) after the arrival of the start of frame at the PE position. The start of frame arrival time at each PE depends on the propagation delay between the Node B and the PE. Similarly, the UE makes a measurement at predetermined instances (defined by IPDL parameters) after the arrival of the start of frame at its position that is determined by the propagation delay between the Node B and UE.

Figure 4.1 illustrates an example of the geometry of the PE method with 4 PEs with $R_2 > R_1 = R_3 > L > R_4$ and $D_2 > D_1 > D_4 > D_3$. Here, R denotes the distance between the Node B to each PE, D denotes the distance between the UE to each PE whilst L is the distance between the Node B and UE and c is the speed of light. Figure 4.2 shows the transmission timing diagram associated with the geometry of Figure 4.1 where T is the known offset between the frame start and beginning of a measurement (idle) period.

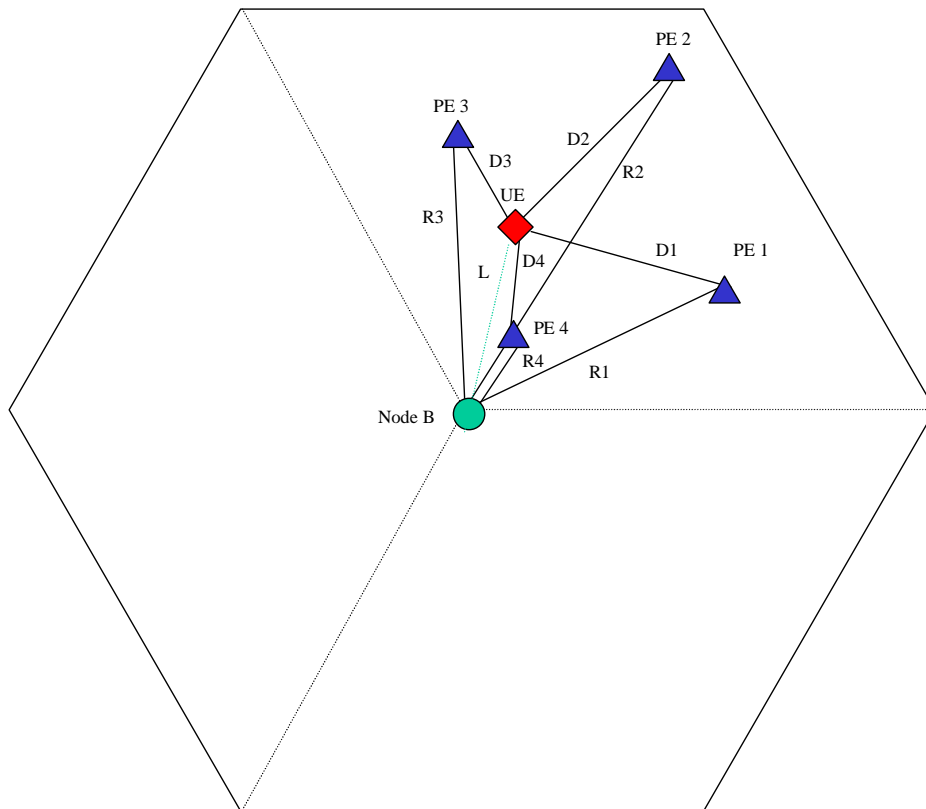

Figure 4.1: Example of PE method geometry

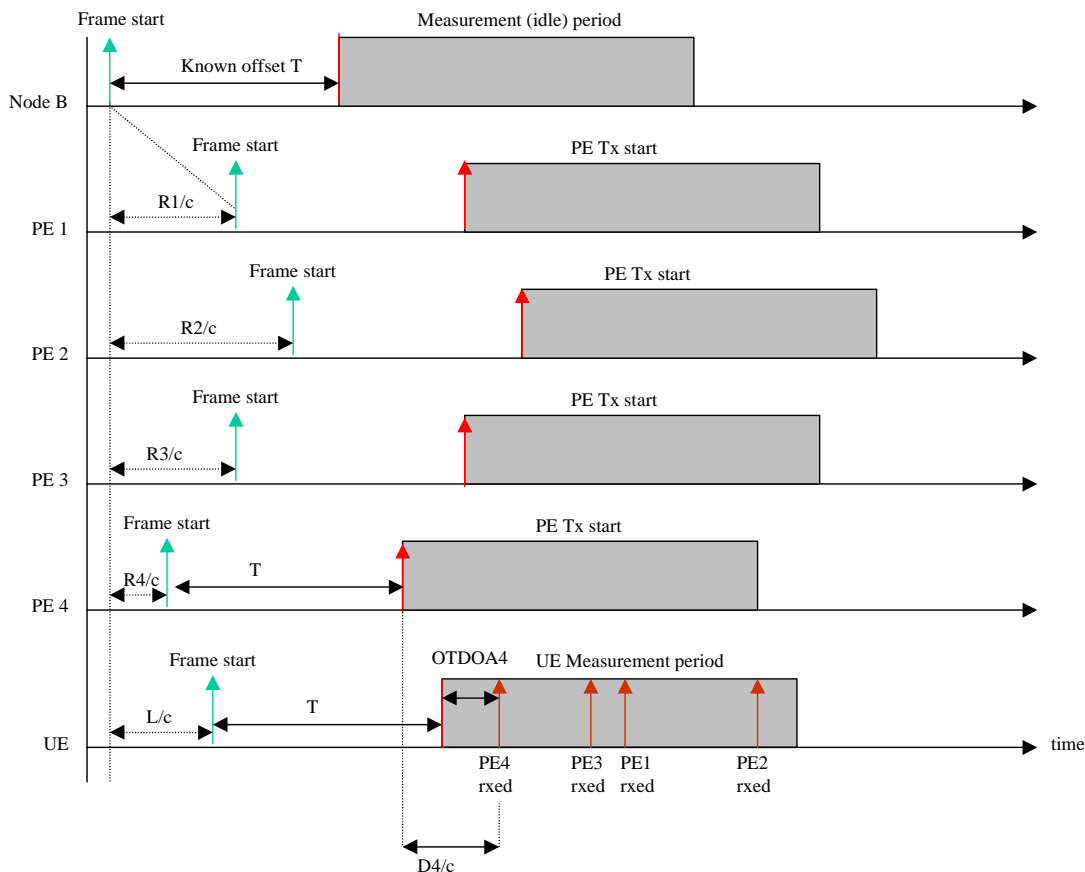

Figure 4.2: PE method timing associated with Figure 4.1 geometry

In Figure 4.2, all timing instances are referenced to the start of frame transmitted by the serving Node B. The measurement window at the UE occurs at time $L/c+T$ later whilst the PE 4 signal arrives at the UE at time $R4/c+T+D4/c$. The difference between these two expressions gives the OTDOA measurement i.e., $OTDOA4=R4/c+D4/c-L/c$ that combined with the information on the exact distance between the Node B and PE4 defines a hyperbola upon which the UE must lie. The intersection of at least two such hyperbolae gives the UE location just as in the case with standard OTDOA measurements made between the UE and Node Bs.

However, unlike OTDOA measurements on asynchronous Node Bs that require LMU measurements of the relative time difference (RTD), PE associated OTDOA measurements are self-contained with regards to timing issues. The complication of the LMU is avoided in the PE method as all PEs are synchronised to the downlink and transmit at the same known offset (T) from the start of frame arrival at the PE position. There are no issues with drifting of the PE transmission instances as the PEs remain closely synchronised to the Node B.

It should be noted that PE OTDOA measurements are disassociated with the number of Node Bs in the UEs active set, or with how many Node Bs the UE is able to decode in idle mode. PE transmission timings are associated with the idle period parameters (whether idle periods are used or not) of a given Node B. A UE will be signalled with the explicit association between PE identifier codes and Node B identities enabling it to perform meaningful measurements on PE signals irrespective of its mobility or whether it is in soft handover or not.

4.4.4.3 Improvement on OTDOA-IPDL

Simulations have been conducted to determine the performance gains of the OTDOA-PE method over the standard OTDOA UE positioning method with and without IPDL for a range of channel conditions. The results show that in the absence of idle periods, the PEs constitute the main source of OTDOA measurements as expected. With 6 PEs, the percentage of measurement instances that result in position calculation (i.e., 2 or more OTDOA measurements) is by a large margin in excess of the equivalent figure for Node B OTDOA measurements only. This reduces the number of measurements that need to be performed by a UE in order to meet a UE positioning request and reduces power consumption. At the same time, the positioning accuracy is significantly improved.

Additionally, the use of the OTDOA-PE method without idle periods allows UE positioning estimates based on simple OTDOA measurements without the impact on Node B complexity that is associated with idle slots.

4.4.4.4 UTRAN UE positioning architecture

4.4.4.4.1 Positioning Elements (PEs)

Positioning elements are network elements that are placed in accurately known locations other than those of the Node B equipment. Each PE will have a serving 3G-MSC, VLR and a subscription profile in an HLR. The HLR profile may be modified to distinguish its operation from a standard UE, e.g. barring of all incoming and outgoing calls. Each PE will be assigned a unique IMSI and support all radio resource and mobility management functions of the UTRAN radio interface that are necessary to support signalling on dedicated channels. A PE shall support those connection management functions necessary to support UE positioning signalling transaction with the CRNC via the serving Node B.

NOTE 1: A network operator may assign specific ranges of IMSI for its PEs and may assign certain digits within the IMSI to indicate the associated CRNC. Certain digits in the IMSI may also be used as a local identifier for a PE within an CRNC.

PEs synchronise to the downlink of a cell and transmit identifying code sequences at known offsets with regard to the arrival of the beginning of the BCH frame at the PE location. The measurements required for the OTDOA-PE method are of the same nature as those required for the standard OTDOA UE positioning method, they are measurements of the observed difference in time of arrival at the UE between signals from the serving Node B and from the PE(s)

PEs are accessed over the UTRAN air (Uu) interface. There is no other connection between PEs and any other network element.

4.4.4.5 Signalling protocols and interfaces

4.4.4.5.1 Signalling between RNC and PEs

Signalling exchanges between an RNC and a PE under the control of that RNC will be specified in the RRC protocol for PEs. The protocol layers employed to enable signalling between the RNC and a PE are defined in TS25.331. The PE signalling information elements are included directly in the RRC protocol, also defined in 25.331.

Figure 4.3 illustrates the protocol layers needed to support signalling between the SRNC and PEs over the Uu interface.

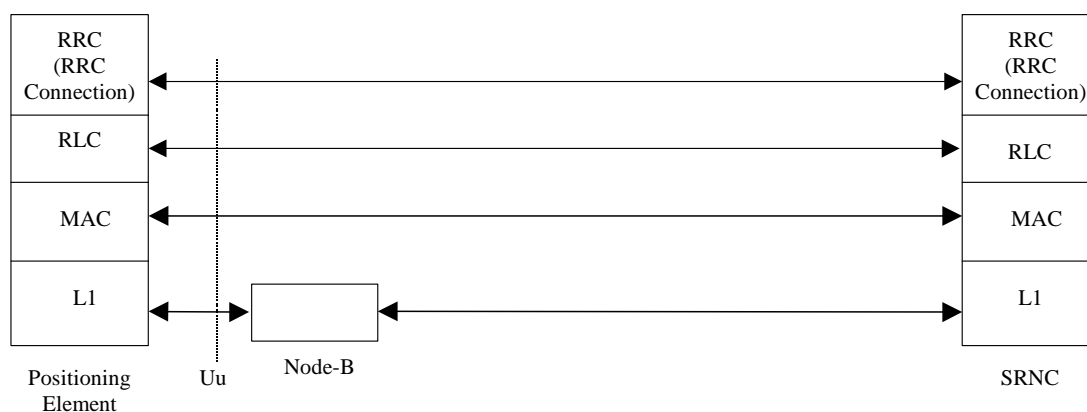

Figure 4.3: Signalling protocol layers between the SRNC and PEs

4.4.4.6 General UTRAN UE positioning procedures

4.4.4.6.1 PE Functions

The PE network element should have the following functionality:

- establish RRC connection to serving Node B and receive configuration parameters
- transmit requested PE identifier code at beginning of idle periods as calculated by each PE

4.4.4.6.2 SRNC-PE Interactions

The following parameters are transferred from the SRNC to the PEs in configuring PE transmissions:

- PE identifier code
- identity of Node B associated with PE identifier code
- PE identifier code transmission power
- Code_length: Expressed in symbols of the CPICH. Shorter in length to the IPDL parameter IP_Length that is signalled to the UEs. This ensures that PE codes are contained within idle periods as seen at any UE position in the cell
- The idle slot parameters IP_Status, IP_Spacing, IP_Offset, Seed, Burst_Start, Burst_Length and Burst_Freq defined in TS25.214 that are identical to those signalled to UEs

4.4.4.6.3 SRNC-UE interactions

The following parameters are transferred from the SRNC to the UEs to support PE transmissions:

- number of PEs detectable in the cell, identifier codes and Node B associated with each code
- Code_length: Expressed in symbols of the CPICH. Shorter in length to the IP_Length parameter that is given to the UEs. This ensures that PE codes are contained within idle periods as seen at any UE position in the cell
- The idle slot parameters IP_Status, IP_Spacing, IP_Offset, Seed, Burst_Start, Burst_Length and Burst_Freq defined in TS25.214 that are identical to those signalled to PEs

4.4.4.7 OTDOA-PE positioning method

4.4.4.7.1 System modes

Positioning elements can be deployed to increase the positioning accuracy when idle slots are used, or can be used as the main reference points for OTDOA measurements when idle slots are not used by the system. In either case, the timing of the transmissions are based on the formulas for calculating the idle slot occurrence.

4.4.4.7.2 UE modes

The time of arrival measurements of the PE codes at the UE can either be utilised directly by the UE or sent to the network. In the former case, termed UE-based mode, the UE combines time of arrival information to form OTDOA measurements that are subsequently used to estimate the UE position. The network provides all supporting information to the UE over the Uu interface. In the UE-assisted mode, the role of the UE is restricted to making and then relaying the time of arrival of the PE codes at the UE to the network over the Uu interface. The transformation of these timing measurements to OTDOA measurements and estimation of the UE position is performed within the network.

4.4.4.7.3 PE modes

PEs can be configured to remain inactive, or transmit in continuous or burst mode as those modes are defined for idle periods. These parameters are given in 4.4.3.6.2. In the absence of idle periods the same definitions and same parameters will be used to define the periods within which the UEs will perform their measurements and at the beginning of which the PEs will start their transmissions.

4.4.4.7.4 Information to be transferred between UTRAN elements

Table 4.1 lists the additional required information for both UE-assisted and UE-based modes that may be sent from SRNC to the UE to support OTDOA-PE positioning. This information can be signalled to the PE in a broadcast channel or as dedicated signalling. Table 4.2 lists the information to be transferred between RNCs across the Iur interface.

Table 4.1: Information to be transferred between SRNC and UE

| Information | UE assisted | UE based |
|--|-------------|----------|
| Neighbouring PE identifier codes list | Yes | Yes |
| Geographical location of the PEs | No | Yes |
| RTD between Node B and PE derived from the distance between them | No | Yes |

Table 4.2: Information to be transferred between RNCs

| Information | UE assisted | UE based |
|---|-------------|----------|
| Geographical location of the PEs | Yes | Yes |
| IPDL-like parameters that define measurement periods when idle slots are not used in the system | Yes | Yes |

4.4.4.7.5 OTDOA-PE network positioning procedures

Figure 4.4 illustrates the operations needed to implement the OTDOA-PE method triggered by an UE positioning request from the core network. Signalling from the SRNC via the Node B configures the relevant PEs. All subsequent operations are identical to the standard OTDOA method.

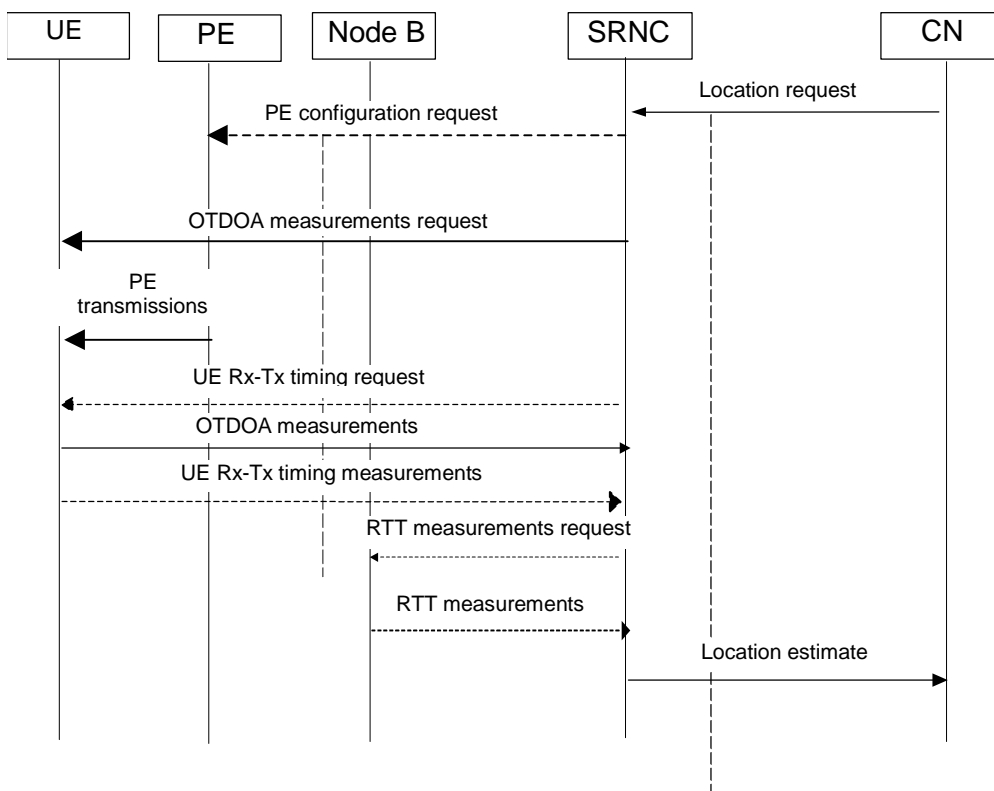

Figure 4.4: OTDOA-PE signalling operations.

4.4.5 Almanac-based DGPS method (DGPS-A)

A GPS satellite orbit can be modelled as a modified elliptical orbit with correction terms to account for various perturbations. In a GPS system, the orbit of the satellite can be represented using either ephemeris or almanac parameters. The short-term ephemeris data provides a very accurate representation of the orbit of the satellite. In contrast, the long-term almanac data provides a truncated reduced precision set of the ephemeris parameters. Consequently, raw satellite positions derived from almanac data tend to be much less accurate (~1km) than those derived from the detailed ephemeris data (~1m).

Currently, Release 99 defines information elements for both almanac and ephemeris orbital models. Note that both optional broadcast and point-to-point mechanisms have been specified for the distribution of these almanac and ephemeris messages [4]. Release 99 also specifies a Differential GPS (DGPS) corrections information element that is used to compensate for orbital, clock, and atmospheric perturbations. The UE-Based technology can employ these *ephemeris-based* DGPS corrections ("DGPS-E" corrections) along with ephemeris information in order to obtain corrected positioning results.

An augmentation to the DGPS correction information specified for Release 4 can enable the network to provide the UE with an optional form of *almanac-based* DGPS corrections ("DGPS-A" corrections). The UE-Based technology can employ these DGPS-A corrections along with almanac information in order to obtain corrected positioning results.

The motivation for pursuing the DGPS-A concept stems from the following basic observations:

- 1) Per satellite, the size of an ephemeris model (~600 bits) is approximately 3 times that of an almanac model (~200 bits). In the case where these orbital models are provided to a UE for 10 visible satellites, about 6000 bits of ephemeris information must be transferred as opposed to 2000 bits of almanac information.
- 2) The useful lifespan of each ephemeris model may be extended to six hours by incorporating DGPS-E corrections into the UE position computation. In contrast, the useful lifespan of each almanac model may be extended to six days by incorporating DGPS-A corrections into the UE position computation. At first glance, a potential 24-fold reduction in orbital model update rate to the UE seems possible for point-to-point assisted GPS operation.
- 3) With respect to DGPS-E corrections, DGPS-A corrections can be provided within an equivalent number of bits.
- 4) With respect to DGPS-E corrections, DGPS-A corrections can be provided with equivalent useful lifespan (e.g., a few minutes or more).

The possible reductions in signalling bandwidth and/or latency realized from broadcasting a combination of almanac information and DGPS-A corrections (instead of ephemeris + DGPS-E corrections) should be assessed for practical UE positioning operations. In a similar manner, the possible reductions in signalling bandwidth and/or latency realized by employing the DGPS-A positioning method in a point-to-point mode should be evaluated for practical use. Note that for the point-to-point assessment, potential reductions in orbital model update rate to the UE may become of interest.

5 Layer 1 impacts

5.1 OTDOA location method in TDD

5.1.1 Impacts of Idle Periods

5.1.1.1 General

To support time difference measurements for location services, idle periods can be created in the downlink (hence the name IPDL) during which time transmission of all channels except for the synchronisation channel from a Node B is temporarily ceased. If an idle period occurs in a slot carrying the synchronisation channel, transmissions on the synchronisation channel shall continue in order to avoid reduced performance of cell search procedures. During these idle periods the visibility of neighbour cells from the UE is improved. For TDD it is more reasonable to cease the transmission during a whole time slot. The idle periods must be arranged in such a way that they occur in the same timeslot as the measurement is performed by the UE on the signals of the neighbouring cells. During Idle periods all channels except for the synchronisation channel are silent simultaneously. By means of higher layer signalling (e.g. channel reconfiguration) it may be possible to shift all transmission during an idle period to other slots in order to prevent the loss of data.

In general there are two modes for these idle periods:

- Continuous mode; and
- Burst mode.

In continuous mode the idle periods are active all the time. In burst mode the idle periods are arranged in bursts where each burst contains enough idle periods to allow a UE to make sufficient measurements for its location to be calculated. The bursts are separated by a period where no idle periods occur.

5.1.2 Parameters of IPDL

The following parameters are signalled to the UE via higher layers:

- **IP_Status:**
This is a logic value that indicates if the idle periods are arranged in continuous or burst mode.
- **IP_Spacing:**
The number of 10 ms radio frames between the start of a radio frame that contains an idle period and the next radio frame that contains an idle period.

NOTE: There is at most one idle period in a radio frame.

- **IP_Start:**
The number of the first frame with idle periods.
- **IP_PCCPCH:**
This logic value indicates, if the P-CCPCH is switched off in two consecutive frames. The first of these two frames contains the idle period.
- **IP_Slot:**
The number of the slot that has to be idle [0..14].

Additionally in the case of burst mode operation the following parameters are also communicated to the UE.

- **Burst_Start:**
The SFN where the first burst of idle periods starts.
- **Burst_Length:**
The number of idle periods in a burst of idle periods.
- **Burst_Freq:**
The number of radio frames between the start of a burst and the start of the next burst.

5.1.3 Calculation of idle period position

In burst mode, the first burst starts in the radio frame with $SFN = Burst_Start$. The n :th burst starts in the radio frame with $SFN = Burst_Start + n \times Burst_Freq$. The sequence of bursts according to this formula continues up to and including the radio frame with $SFN = 4095$. At the start of the radio frame with $SFN = 0$, the burst sequence is terminated (no idle periods are generated) and at $SFN = Burst_Start$ the burst sequence is restarted with the first burst followed by the second burst etc., as described above.

Continuous mode is equivalent to burst mode, with only one burst spanning the whole SFN cycle of 4096 radio frames. In case of continuous mode the parameter IP_Start defines the first frame with idle periods. Assume that $IP_Frame(x)$ is the frame with the idle period number x within a burst, where $x = 1, 2, \dots$.

The time slot that has to be idle is defined by two values: $IP_Frame(x)$ and IP_Slot . $IP_Frame(x)$ defines the x^{th} frame within a burst in which the slot with the number IP_Slot has to be switched off.

The actual frame with idle periods within a burst is calculated as follows:

$$IP_Frame(x) = IP_Start + (x-1) \times IP_Spacing \text{ with } x = 1, 2, 3, \dots$$

Note that x is reset to $x = 1$ for the first idle period in every burst.

If the parameter IP_PCCPCH is set to 1, then the P-CCPCH will not be transmitted in the frame $IP_Frame(x) + 1$ within a burst.

Figure 5.1 below illustrates the idle periods for the burst mode case.

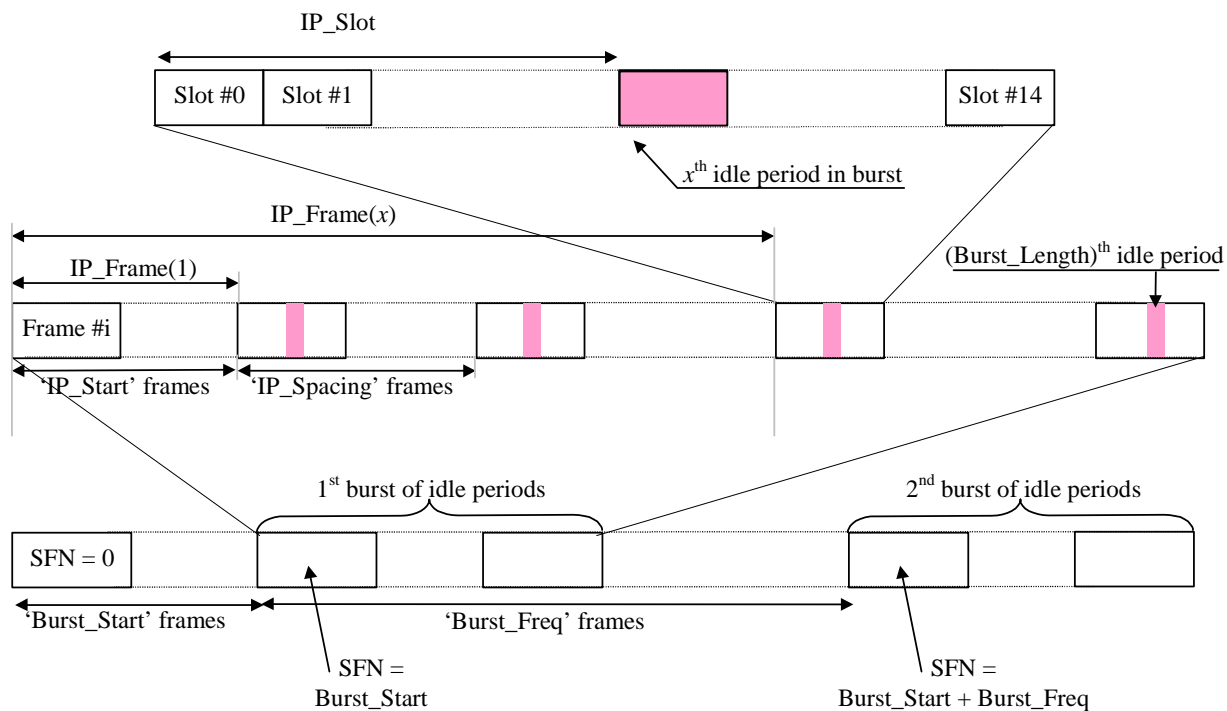

Figure 5.1: Idle periods for the burst mode case

5.1.4 Impact on the Open Loop Power Control

According to [4], the transmitter power of the UE is calculated by:

$$P_{UL} = \alpha L_{P-CCPCH} + (1-\alpha) L_0 + I_{BTS} + SIR_{TARGET} + \text{Constant value}$$

If the IPDLs occur within a slot carrying the PCCPCH, the impact of this on the Open Loop Power Control has to be taken into account by using a different alpha (alpha-r4) parameter (see [4]). The alpha parameter is a weighting parameter representing the quality of the path loss estimation. This modified alpha parameter has to be signalled to the UE in addition to the original alpha parameter, which should be set to alpha=0. Therefore Release 99 UEs only use the average path loss (Lo) for Open Loop Power Control.

Additionally a maximum power increase threshold is given to the UE, in order to prevent too big changes in the Tx power.

5.2 OTDOA-PE method

5.2.1 PE impact

5.2.1.1 UE complexity

The measurement utilising the PE signal is similar to a type-2 OTDOA measurement that the UE is already capable of performing. Two candidate schemes have been considered for generating the PE transmitted signals. One scheme uses codes comprising symbols generated with the same process as the system S-SCH codes (but not used elsewhere in the system). An alternative scheme using the first few symbols of downlink scrambling codes (SCd1) that are not used in neighbouring cells is also being investigated. These S-SCH and SCd1 type PE codes on which the OTDOA measurement is performed add no complexity to a UE terminal as no additional circuitry is required to generate such codes.

With the PE method, it is the number but not the type of measurements that is increased. The number of the actual measurements increases with the number of additional reference points on offer, i.e., with the number of PEs visible to

the UE. This higher number of reference points leads directly to the increase in positioning accuracy of the PE method over the standard OTDOA method.

5.2.1.2 UE cell search/synchronisation

The potential for S-SCH based PE identifier codes interfering with the initial UE synchronisation process is extremely low. The chosen PE codes are not used elsewhere in the system and PE transmissions will be configured so that, as would be the case with idle slots, at all possible UE positions, PE code reception does not overlap with the SCH codes transmitted by the serving Node B. In the event of overlap with SCH codes from adjacent cells, even high cross correlation products with PE transmissions are unlikely to confuse the UE synchronisation process as PE transmissions occur a maximum of once per frame.

5.2.1.3 PE complexity

Positioning elements are envisaged to be small in size (handset like) and configured via the Uu air interface. Their transmitted power will be of the order of handset transmissions with the possibility of being powered by small solar panels. No hardware modifications are needed to Node B for connecting to the PEs.

5.2.1.4 Capacity issues

Positioning accuracy based on OTDOA measurements made by R99 UEs that are not aware of PE transmissions during idle periods could be degraded. PEs may therefore have to be kept inactive when the network employs idle periods and there are R99 UEs that could use the idle periods to perform OTDOA measurements.

Link level simulations are underway to determine the impact of PE transmissions on the capacity of adjacent cells. The short period of the PE transmissions and the relatively low power at which these are made are expected to mitigate this effect.

6 Impacts on UTRAN interfaces

6.1 OTDOA location method

6.1.1 Impacts of IPDLs in TDD

In TDD transmissions an IPDL lasts for a whole slot. The position within the frames of the slot that is used for IPDLs is always the same and can only be changed via explicit signalling.

Occurrences of IPDLs in TDD do not pursue a pseudo-random pattern. In order to avoid overlapping IPDLs of neighbouring cells which are associated to different RNCs, the RNCs should coordinate their IPDL configurations via RNSAP signalling. The parameters of the Idle Periods can be found in clause 5.

Additionally, Node B has to be configured in order to support IPDLs and therefore the IPDL parameters have to be signalled from CRNC to Node B via NBAP signalling.

6.2 OTDOA-PE method

6.2.1 PE impact on network

Signalling load due to reconfiguration is negligible as this takes place very infrequently, in response to large variations in cell interference levels or when PEs are being added or removed. Simulations have shown no need to make any adjustments in response to slow or fast fading.

The OTDOA-PE method is also self-contained with regards to timing issues (relative time differences) and does not require the use of an LMU. This is in contrast to Node B OTDOA measurements that require the assistance of LMUs to monitor and signal the timing offsets of the asynchronous Node Bs.

7 Specification Impacts

7.1 OTDOA IPDLs for TDD

The following specifications are impacted by introducing IPDLs in TDD:

- TS 25.305 Stage 2 Functional Specification of UE positioning in UTRAN
Corresponding CRs:
CR 048r1 to 25.305 [Rel-4] on Introduction of IPDLs for TDD (Siemens)
- TS 25.331 Radio Resource Control
Corresponding CRs:
CR 722r1 to 25.331 [Rel-4] on Introduction of IPDLs for TDD (Siemens)
- TS 25.221 Physical channels and mapping of transport channels onto physical channels (TDD)
Corresponding CRs:
CR 044 'Correction of beacon characteristics due to IPDLs'
- TS 25.224 Physical Layer Procedures (TDD)
Corresponding CRs:
CR 048 Idle periods for IPDL location method
- TS 25.423 UTRAN Iur Interface RNSAP specification
Corresponding CRs:
CR 328 'Introduction of Information Exchange procedures in RNSAP';
- TS 25.413 UTRAN Iub Interface NBAP specification
Within TS 25.413, the UE positioning IPDL parameters for TDD have to be introduced. The signalling procedure is currently specified by RAN WG3.
Corresponding CRs:
CR 381 Introduction of the network configurable idle periods for OTDOA UE Positioning function

Annex A: Change history

| Change history | | | | | | | |
|----------------|-------|-----------|----|-----|--|-----|-------|
| Date | TSG # | TSG Doc. | CR | Rev | Subject/Comment | Old | New |
| 03/2001 | RP-11 | RP-010046 | - | | TO BE Approved at TSG-RAN #11 and placed under Change Control | - | 3.0.0 |
| | | | | | | | |