

Clauses affected:

1, 2, 3.2, 4, 5, 6.1, 6.2, 7, 8.1.3.1, 8.1.3.2, 8.1.3.3, 8.1.3.4, 8.1.3.5, 8.1.3.6, 8.1.3.7, 8.1.3.8, 8.1.3.9, 8.1.4.1, 8.1.4.2, 8.1.4.3, 8.1.4.4, 8.1.4.5, 8.1.4.6, 8.1.4.7, 8.1.4.8, 8.1.4.9, 8.1.4.10, 8.1.5.1, 8.1.5.2, 8.1.5.3, 8.1.5.4, 8.1.5.5, 8.1.5.6, 8.1.5.7, 8.1.5.8, 8.1.5.9, 8.1.5.10, 8.1.6.1, 8.1.6.2, 8.1.6.3, 8.1.6.4, 8.1.6.5, 8.1.6.6, 8.1.7.1, 8.1.7.2, 8.1.7.3, 8.1.7.4, 8.1.8.2, 8.3.1, 8.3.1.1, 8.3.1.2, 8.3.1.3, 8.3.1.3.1, 8.3.1.3.2, 8.3.1.4, 8.3.1.5, 8.3.1.6, 8.3.1.7, 8.3.1.8, 8.3.1.9, 8.3.1.10, 8.3.2, 8.3.2.1, 8.3.2.1, 8.3.2.3, 8.3.2.3.1, 8.3.2.3.2, 8.3.2.4, 8.3.2.5, 8.3.2.6, 8.3.2.7, 8.3.2.8, 8.3.2.9, 8.3.3.1, 8.3.3.2, 8.3.3.3, 8.3.3.4, 8.3.3.5, 8.3.4.1, 8.3.4.2, 8.3.4.3, 8.3.4.4, 8.3.4.5, 8.3.4.6, 8.3.4.7, 8.3.4.8, 8.3.4.9, 8.3.5.1, 8.3.5.1.1, 8.3.5.1.2, 8.3.5.2, 8.3.5.2.1, 8.3.5.2.2, 8.3.6, 8.3.6.1, 8.3.6.2, 8.3.6.3, 8.3.6.4, 8.3.6.5, 8.3.6.6, 8.3.7, 8.3.7.1, 8.3.7.2, 8.3.7.3, 8.3.7.4, 8.3.7.5, 8.3.7.6, 8.3.7.7, 8.3.8.1, 8.3.8.2, 8.3.8.3, 8.3.9, 8.3.9.1, 8.3.9.2, 8.3.9.3, 8.3.9.4, 8.5, 8.5.1, 8.5.2, 8.5.3, 8.5.4, 8.5.5, 8.5.6, 8.5.7, 8.5.8, 8.5.9, 8.5.13, 8.5.14, 8.5.15, 8.5.16, 8.5.17, 8.5.17.1, 8.5.17.2, 8.5.17.3, 8.6, 8.6.1, 8.6.1.1, 8.6.1.2, 8.6.2, 8.6.2.1, 8.6.3, 8.6.3.1, 8.6.3.2, 8.6.3.3, 8.6.3.4, 8.6.3.5, 8.6.3.6, 8.6.3.7, 8.6.3.8, 8.6.3.9, 8.6.4, 8.6.4.1, 8.6.4.2, 8.6.4.3, 8.6.5, 9.6.5.1, 9.6.5.2, 9.6.5.3, 8.6.6, 8.6.6.1, 8.6.6.2, 8.6.6.3, 8.6.6.4, 8.6.6.5, 8.6.6.6, 8.6.6.7, 8.6.6.8, 8.6.6.9, 8.6.6.10, 8.6.6.11, 8.6.6.12, 8.6.6.13, 8.6.6.14, 8.6.6.15, 8.6.6.16, 8.6.6.17, 8.6.6.18, 8.6.6.19, 8.6.6.20, 8.6.6.21, 8.6.7, 8.6.7.1, 8.6.7.2, 8.6.7.3, 8.6.7.4, 8.6.7.5, 8.6.7.6, 8.6.8, 8.6.8.1, 10.2.56, 10.2.57, 10.2.58, 10.2.59, 10.2.60, 10.2.63, 13, 13.1, 13.2, 13.3, 13.4, 13.4.1, 13.4.2, 13.4.2.a (new), 13.4.3, 13.4.4, 13.4.5, 13.4.5a-13.4.5e (new), 13.4.6, 13.4.7, 13.4.8, 13.4.9, 13.4.10, 13.4.11, 13.4.12, 13.4.13, 13.4.14, 13.4.15, 13.4.16, 13.4.17, 15, 16.1, 16.2, 16.3, 16.4, 16.5, 16.6, 16.7, 16.8, 17, 18, 18.1, Annex A, A.1,

Other specs affected:

Other 3G core specifications
Other GSM core specifications
MS test specifications
BSS test specifications
O&M specifications

→ List of CRs:
→ List of CRs:
→ List of CRs:
→ List of CRs:
→ List of CRs:

Other comments:

In order to ease the checking of the differences, the text moved from section 9 to Annex B is only marked as revised in Annex B if actually modified.

The changes made by Nokia to rev 4 compared to rev 3 are summarised section by section in the attached file:



"Summary of change.doc"

3GPP TS 25.331 V3.4.1 (2000-09)

Technical Specification

3rd Generation Partnership Project; Technical Specification Group Radio Access Network; RRC Protocol Specification (Release 1999)



The present document has been developed within the 3rd Generation Partnership Project (3GPP TM) and may be further elaborated for the purposes of 3GPP.

The present document has not been subject to any approval process by the 3GPP Organizational Partners and shall not be implemented.

~~This Specification is provided for future development work within 3GPP only. The Organizational Partners accept no liability for any use of this Specification.~~

Keywords

UMTS, radio

3GPP

Postal address

3GPP support office address

650 Route des Lucioles - Sophia Antipolis
Valbonne - FRANCE

Tel.: +33 4 92 94 42 00 Fax: +33 4 93 65 47 16

Internet

<http://www.3gpp.org>

Copyright Notification

No part may be reproduced except as authorized by written permission.
The copyright and the foregoing restriction extend to reproduction in all media.

© 2000, 3GPP Organizational Partners (ARIB, CWTS, ETSI, T1, TTA, TTC).
All rights reserved.

Contents

Foreword	21
1 Scope.....	22
2 References.....	22
3 Definitions and abbreviations	23
3.1 Definitions	23
3.2 Abbreviations.....	23
4 General.....	25
5 RRC Services provided to upper layers	28
6 Services expected from lower layers	28
6.1 Services expected from Layer 2.....	28
6.2 Services expected from Layer 1.....	28
7 Functions of RRC	28
8 RRC procedures	29
8.1 RRC Connection Management Procedures.....	29
8.1.1 Broadcast of system information.....	Error! Bookmark not defined.
8.1.1.1 General.....	Error! Bookmark not defined.
8.1.1.1.1 System information structure	Error! Bookmark not defined.
8.1.1.1.2 System information blocks.....	Error! Bookmark not defined.
8.1.1.1.3 Segmentation and concatenation of system information blocks	Error! Bookmark not defined.
8.1.1.1.4 Re-assembly of segments.....	Error! Bookmark not defined.
8.1.1.1.5 Scheduling of system information.....	Error! Bookmark not defined.
8.1.1.2 Initiation.....	Error! Bookmark not defined.
8.1.1.3 Reception of SYSTEM INFORMATION messages by the UE	Error! Bookmark not defined.
8.1.1.3.1 Reception of SYSTEM INFORMATION messages broadcast on a BCH transport channel.....	Error! Bookmark not defined.
8.1.1.3.2 Reception of SYSTEM INFORMATION messages broadcast on a FACH transport channel.....	Error! Bookmark not defined.
8.1.1.4 Modification of system information	Error! Bookmark not defined.
8.1.1.4.1 Modification of system information blocks using a value tag.....	Error! Bookmark not defined.
8.1.1.4.2 Modification of system information without value tag.....	Error! Bookmark not defined.
8.1.1.4.3 Time critical modification of system information blocks	Error! Bookmark not defined.
8.1.1.5 Actions upon reception of system information blocks.....	Error! Bookmark not defined.
8.1.1.5.1 System Information Block type 1.....	Error! Bookmark not defined.
8.1.1.5.2 System Information Block type 2.....	Error! Bookmark not defined.
8.1.1.5.3 System Information Block type 3.....	Error! Bookmark not defined.
8.1.1.5.4 System Information Block type 4.....	Error! Bookmark not defined.
8.1.1.5.5 System Information Block type 5.....	Error! Bookmark not defined.
8.1.1.5.6 System Information Block type 6.....	Error! Bookmark not defined.
8.1.1.5.7 System Information Block type 7.....	Error! Bookmark not defined.
8.1.1.5.8 System Information Block type 8.....	Error! Bookmark not defined.
8.1.1.5.9 System Information Block type 9.....	Error! Bookmark not defined.
8.1.1.5.10 System Information Block type 10.....	Error! Bookmark not defined.
8.1.1.5.11 System Information Block type 11.....	Error! Bookmark not defined.
8.1.1.5.12 System Information Block type 12.....	Error! Bookmark not defined.
8.1.1.5.13 System Information Block type 13.....	Error! Bookmark not defined.
8.1.1.5.14 System Information Block type 14.....	Error! Bookmark not defined.
8.1.1.5.15 System Information Block type 15.....	Error! Bookmark not defined.
8.1.1.5.16 System Information Block type 16.....	Error! Bookmark not defined.
8.1.1.5.17 System Information Block type 17.....	Error! Bookmark not defined.
8.1.2 Paging.....	29
8.1.2.1 General.....	29
8.1.2.2 Initiation.....	29
8.1.2.3 Reception of an PAGING TYPE 1 message by the UE.....	29
8.1.3 RRC connection establishment.....	30

8.1.3.1	General.....	30
8.1.3.2	Initiation.....	31
8.1.3.3	Reception of an RRC CONNECTION REQUEST message by the UTRAN.....	31
8.1.3.4	Reception of an RRC CONNECTION SETUP message by the UE.....	32
8.1.3.5	Physical channel failure or T300 timeout	33
8.1.3.6	Invalid RRC CONNECTION SETUP message.....	34
8.1.3.7	Reception of an RRC CONNECTION REJECT message by the UE.....	35
8.1.3.8	Invalid RRC CONNECTION REJECT message.....	37
8.1.3.9	Reception of an RRC CONNECTION SETUP COMPLETE message by the UTRAN	38
8.1.4	RRC connection release	38
8.1.4.1	General.....	39
8.1.4.2	Initiation.....	39
8.1.4.3	Reception of an RRC CONNECTION RELEASE message by the UE	39
8.1.4.4	Invalid RRC CONNECTION RELEASE message	40
8.1.4.5	Expiry of timer T308, unacknowledged mode transmission.....	41
8.1.4.6	Successful transmission of the RRC CONNECTION RELEASE COMPLETE message, acknowledged mode transmission	41
8.1.4.7	Reception of an RRC CONNECTION RELEASE COMPLETE message by UTRAN.....	41
8.1.4.8	Unsuccessful transmission of the RRC CONNECTION RELEASE COMPLETE message, acknowledged mode transmission	41
8.1.4.9	Detection of loss of dedicated physical channel by UTRAN in CELL_DCH state	42
8.1.4.10	No reception of an RRC CONNECTION RELEASE COMPLETE message by UTRAN	42
8.1.5	RRC connection re-establishment	42
8.1.5.1	General.....	42
8.1.5.2	Initiation.....	42
8.1.5.3	Detection of "in service area"	43
8.1.5.4	Reception of an RRC CONNECTION RE-ESTABLISHMENT REQUEST message by the UTRAN	43
8.1.5.5	Reception of an RRC CONNECTION RE-ESTABLISHMENT message by the UE.....	44
8.1.5.6	T314 timeout.....	45
8.1.5.7	T315 timeout.....	45
8.1.5.8	Invalid RRC CONNECTION RE-ESTABLISHMENT message.....	45
8.1.5.9	T301 timeout or DPCH failure	46
8.1.5.10	Reception of an RRC CONNECTION RE-ESTABLISHMENT COMPLETE message by the UTRAN	47
8.1.6	Transmission of UE capability information	47
8.1.6.1	General.....	47
8.1.6.2	Initiation.....	47
8.1.6.3	Reception of an UE CAPABILITY INFORMATION message by the UTRAN	48
8.1.6.4	Reception of the UE CAPABILITY INFORMATION CONFIRM message by the UE.....	48
8.1.6.5	Invalid UE CAPABILITY INFORMATION CONFIRM message.....	48
8.1.6.6	T304 timeout.....	48
8.1.7	UE capability enquiry.....	49
8.1.7.1	General.....	49
8.1.7.2	Initiation.....	49
8.1.7.3	Reception of an UE CAPABILITY ENQUIRY message by the UE.....	49
8.1.7.4	Invalid UE CAPABILITY ENQUIRY message.....	49
8.1.8	Initial Direct transfer	50
8.1.8.1	General.....	50
8.1.8.2	Initiation of Initial direct transfer procedure in the UE.....	50
8.1.8.3	Reception of INITIAL DIRECT TRANSFER message by the UTRAN.....	50
8.1.9	Downlink Direct transfer.....	51
8.1.9.1	General.....	51
8.1.9.2	Initiation of downlink direct transfer procedure in the UTRAN.....	51
8.1.9.3	Reception of a DOWNLINK DIRECT TRANSFER message by the UE	51
8.1.9.4	Invalid DOWNLINK DIRECT TRANSFER message	51
8.1.10	Uplink Direct transfer.....	53
8.1.10.1	General.....	53
8.1.10.2	Initiation of uplink direct transfer procedure in the UE.....	53
8.1.10.3	Reception of UPLINK DIRECT TRANSFER message by the UTRAN.....	53
8.1.11	UE dedicated paging	54
8.1.11.1	General.....	54

8.1.11.2	Initiation.....	54
8.1.11.3	Reception of an PAGING TYPE 2 message by the UE.....	54
8.1.11.4	Invalid PAGING TYPE 2 message.....	54
8.1.12	Security mode control	55
8.1.12.1	General.....	55
8.1.12.2	Initiation.....	55
8.1.12.2.1	Ciphering configuration change	55
8.1.12.2.2	Integrity protection configuration change	56
8.1.12.3	Reception of SECURITY MODE COMMAND message by the UE.....	56
8.1.12.4	Cipher activation time too short.....	57
8.1.12.5	Reception of SECURITY MODE COMPLETE message by the UTRAN.....	57
8.1.12.6	Invalid SECURITY MODE COMMAND message	57
8.1.13	Signalling flow release procedure	58
8.1.13.1	General.....	58
8.1.13.2	Initiation of SIGNALLING CONNECTION RELEASE by the UTRAN.....	58
8.1.13.3	Reception of SIGNALLING FLOW RELEASE by the UE	58
8.1.13.4	Invalid SIGNALLING FLOW RELEASE message.....	58
8.1.14	Signalling connection release request procedure.....	59
8.1.14.1	General.....	59
8.1.14.2	Initiation.....	59
8.1.14.3	Reception of SIGNALLING CONNECTION RELEASE REQUEST by the UTRAN	59
8.1.15	Counter check.....	59
8.1.15.1	General.....	60
8.1.15.2	Initiation.....	60
8.1.15.3	Reception of a COUNTER CHECK message by the UE	60
8.1.15.4	Reception of the COUNTER CHECK RESPONSE message by UTRAN.....	60
8.1.15.5	Invalid COUNTER CHECK message	60
8.2	Radio Bearer control procedures.....	Error! Bookmark not defined.
8.2.1	Radio bearer establishment.....	Error! Bookmark not defined.
8.2.1.1	General.....	Error! Bookmark not defined.
8.2.1.2	Initiation.....	Error! Bookmark not defined.
8.2.1.3	Reception of a RADIO BEARER SETUP message by the UE	Error! Bookmark not defined.
8.2.1.4	Unsupported configuration in the UE	Error! Bookmark not defined.
8.2.1.5	Physical channel failure.....	Error! Bookmark not defined.
8.2.1.6	Reception of the RADIO BEARER SETUP COMPLETE message by the UTRAN.....	Error! Bookmark not defined.
8.2.1.7	Reception of RADIO BEARER SETUP FAILURE by the UTRAN	Error! Bookmark not defined.
8.2.1.8	Subsequently received RADIO BEARER SETUP messages	Error! Bookmark not defined.
8.2.1.9	Incompatible simultaneous reconfiguration.....	Error! Bookmark not defined.
8.2.1.10	Invalid RADIO BEARER SETUP message	Error! Bookmark not defined.
8.2.2	Reconfiguration procedures.....	Error! Bookmark not defined.
8.2.2.1	General.....	Error! Bookmark not defined.
8.2.2.2	Initiation.....	Error! Bookmark not defined.
8.2.2.3	Reception of RADIO BEARER RECONFIGURATION or TRANSPORT CHANNEL RECONFIGURATION or PHYSICAL CHANNEL RECONFIGURATION by the UE in CELL_DCH state.....	Error! Bookmark not defined.
8.2.2.4	Reception of a RADIO BEARER RECONFIGURATION or TRANSPORT CHANNEL RECONFIGURATION or PHYSICAL CHANNEL RECONFIGURATION message by the UE in CELL_FACH state	Error! Bookmark not defined.
8.2.2.5	Reception of a RADIO BEARER RECONFIGURATION COMPLETE OR TRANSPORT CHANNEL RECONFIGURATION COMPLETE or PHYSICAL CHANNEL RECONFIGURATION COMPLETE message by the UTRAN.....	Error! Bookmark not defined.
8.2.2.6	Unsupported configuration in the UE	Error! Bookmark not defined.
8.2.2.7	Physical channel failure	Error! Bookmark not defined.
8.2.2.8	Reception of a RADIO BEARER RECONFIGURATION FAILURE or TRANSPORT CHANNEL RECONFIGURATION FAILURE or PHYSICAL CHANNEL RECONFIGURATION FAILURE message by the UTRAN.....	Error! Bookmark not defined.
8.2.2.9	No response from the UE in CELL_DCH state	Error! Bookmark not defined.
8.2.2.10	No response from the UE in CELL_FACH state.....	Error! Bookmark not defined.
8.2.2.11	Physical channel failure during transition from CELL_DCH to CELL_FACH.....	Error! Bookmark not defined.
8.2.2.12	Suspension of signalling bearer	Error! Bookmark not defined.
8.2.2.13	Subsequently received RADIO BEARER RECONFIGURATION or TRANSPORT CHANNEL RECONFIGURATION or PHYSICAL CHANNEL RECONFIGURATION messages.....	Error! Bookmark not defined.

8.2.2.14	Incompatible simultaneous reconfiguration.....	Error! Bookmark not defined.
8.2.2.15	Invalid RADIO BEARER RECONFIGURATION or TRANSPORT CHANNEL RECONFIGURATION or PHYSICAL CHANNEL RECONFIGURATION message	Error! Bookmark not defined.
8.2.3	Radio bearer release	Error! Bookmark not defined.
8.2.3.1	General.....	Error! Bookmark not defined.
8.2.3.2	Initiation.....	Error! Bookmark not defined.
8.2.3.3	Reception of RADIO BEARER RELEASE by the UE	Error! Bookmark not defined.
8.2.3.4	Unsupported configuration in the UE	Error! Bookmark not defined.
8.2.3.5	Physical channel failure.....	Error! Bookmark not defined.
8.2.3.6	Reception of the RADIO BEARER RELEASE COMPLETE message by the UTRAN	Error! Bookmark not defined.
8.2.3.7	Reception of the RADIO BEARER RELEASE FAILURE message by the UTRAN	Error! Bookmark not defined.
8.2.3.8	Physical channel failure during transition from CELL_DCH to CELL_FACH	Error! Bookmark not defined.
8.2.3.9	Subsequently received RADIO BEARER RELEASE messages.....	Error! Bookmark not defined.
8.2.3.10	Incompatible simultaneous reconfiguration.....	Error! Bookmark not defined.
8.2.3.11	Invalid RADIO BEARER RELEASE message.....	Error! Bookmark not defined.
8.2.4	Transport channel reconfiguration.....	Error! Bookmark not defined.
8.2.5	Transport format combination control.....	Error! Bookmark not defined.
8.2.5.1	General.....	Error! Bookmark not defined.
8.2.5.2	Initiation.....	Error! Bookmark not defined.
8.2.5.3	Reception of a TRANSPORT FORMAT COMBINATION CONTROL message by the UE	Error! Bookmark not defined.
8.2.5.4	Incompatible simultaneous reconfiguration.....	Error! Bookmark not defined.
8.2.5.5	Invalid TRANSPORT FORMAT COMBINATION CONTROL message	Error! Bookmark not defined.
8.2.6	Physical channel reconfiguration.....	Error! Bookmark not defined.
8.2.7	Physical Shared Channel Allocation [TDD only].....	Error! Bookmark not defined.
8.2.7.1	General.....	Error! Bookmark not defined.
8.2.7.2	Initiation.....	Error! Bookmark not defined.
8.2.7.3	Reception of a PHYSICAL SHARED CHANNEL ALLOCATION message by the UE	Error! Bookmark not defined.
8.2.7.4	Invalid PHYSICAL SHARED CHANNEL ALLOCATION message..	Error! Bookmark not defined.
8.2.8	PUSCH capacity request [TDD only]	62
8.2.8.1	General.....	62
8.2.8.2	Initiation.....	62
8.2.8.3	Reception of a PUSCH CAPACITY REQUEST message by the UTRAN.....	63
8.2.8.4	T310 time out.....	63
8.2.9	Downlink outer loop control	Error! Bookmark not defined.
8.2.9.1	General.....	Error! Bookmark not defined.
8.2.9.2	Initiation.....	Error! Bookmark not defined.
8.2.9.3	Reception of DOWNLINK OUTER LOOP CONTROL message by the UE	Error! Bookmark not defined.
8.2.9.4	Invalid DOWNLINK OUTER LOOP CONTROL message	Error! Bookmark not defined.
8.2.10	Uplink Physical Channel Control [TDD only]	Error! Bookmark not defined.
8.2.10.1	General.....	Error! Bookmark not defined.
8.2.10.2	Initiation.....	Error! Bookmark not defined.
8.2.10.3	Reception of UPLINK PHYSICAL CHANNEL CONTROL message by the UE	Error! Bookmark not defined.
8.2.10.4	Invalid UPLINK PHYSICAL CHANNEL CONTROL message.....	Error! Bookmark not defined.
8.2.11	Physical channel reconfiguration failure	Error! Bookmark not defined.
8.2.11.1	General.....	Error! Bookmark not defined.
8.2.11.2	Runtime error due to overlapping compressed mode configuration	Error! Bookmark not defined.
8.3	RRC connection mobility procedures	64
8.3.1	Cell update.....	64
8.3.1.1	General.....	66
8.3.1.2	Initiation.....	67
8.3.1.3	T305 expiry and the UE detects that it is out of service area.....	70
8.3.1.3.1	Re-entering of service area.....	71
8.3.1.3.2	Expiry of timer T307.....	71
8.3.1.4	Reception of an CELL UPDATE message by the UTRAN	71
8.3.1.5	Reception of the CELL UPDATE CONFIRM message by the UE.....	72
8.3.1.6	Invalid CELL UPDATE CONFIRM message.....	78
8.3.1.7	T302 expiry or cell reselection	78
8.3.1.8	Reception of the UTRAN MOBILITY INFORMATION CONFIRM message by the UTRAN	79
8.3.1.9	Reception of the PHYSICAL CHANNEL RECONFIGURATION COMPLETE message by the UTRAN	79
8.3.1.10	Reception of the TRANSPORT CHANNEL RECONFIGURATION COMPLETE message by the UTRAN.....	79

8.3.2	URA update	80
8.3.2.1	General.....	80
8.3.2.2	Initiation.....	81
8.3.2.3	T306 expiry and the UE detects that it is out of service area	82
-	re-select to a new cell, as described in [4].8.3.2.3.1 Re-entering of service area	82
8.3.2.3.2	Expiry of timer T307.....	83
8.3.2.4	Reception of an URA UPDATE message by the UTRAN	83
8.3.2.5	Reception of an URA UPDATE CONFIRM message by the UE	83
8.3.2.6	Confirmation error of URA ID list	85
8.3.2.7	Invalid URA UPDATE CONFIRM message	86
8.3.2.8	T303 expiry or URA reselection.....	86
8.3.2.9	Reception of the UTRAN MOBILITY INFORMATION CONFIRM message by the UTRAN	87
8.3.3	UTRAN mobility information	87
8.3.3.1	General.....	87
8.3.3.2	Initiation.....	87
8.3.3.3	Reception of UTRAN MOBILITY INFORMATION message by the UE	88
8.3.3.4	Reception of an UTRAN MOBILITY INFORMATION CONFIRM message by the UTRAN	89
8.3.3.5	Invalid UTRAN MOBILITY INFORMATION message.....	89
8.3.4	Active set update	90
8.3.4.1	General.....	90
8.3.4.2	Initiation.....	90
8.3.4.3	Reception of an ACTIVE SET UPDATE message by the UE	91
8.3.4.4	Abnormal case: Unsupported configuration in the UE.....	91
8.3.4.5	Reception of the ACTIVE SET UPDATE COMPLETE message by the UTRAN.....	92
8.3.4.6	Reception of the ACTIVE SET UPDATE FAILURE message by the UTRAN.....	92
8.3.4.7	Subsequently received ACTIVE SET UPDATE messages	92
8.3.4.8	Incompatible simultaneous reconfiguration.....	93
8.3.4.9	Invalid ACTIVE SET UPDATE message	93
8.3.5	Hard handover	93
8.3.5.1	Non-synchronised hard handover	93
8.3.5.1.1	General.....	93
8.3.5.1.2	Initiation	93
8.3.5.2	Synchronised hard handover.....	94
8.3.5.2.1	General.....	94
8.3.5.2.2	Initiation	94
8.3.6	Inter-system handover to UTRAN	94
8.3.6.1	General.....	94
8.3.6.2	Initiation.....	95
8.3.6.3	Reception of Handover to UTRAN command message by the UE	95
8.3.6.4	Invalid Handover to UTRAN command message	95
8.3.6.5	UE fails to perform handover	96
8.3.6.6	Reception of message HANDOVER TO UTRAN COMPLETE by the UTRAN.....	96
8.3.7	Inter-system handover from UTRAN.....	96
8.3.7.1	General.....	96
8.3.7.2	Initiation.....	96
8.3.7.3	Reception of an INTER- SYSTEM HANDOVER COMMAND message by the UE	96
8.3.7.4	Successful completion of the inter-system handover.....	97
8.3.7.5	UE fails to complete requested handover	97
8.3.7.6	Invalid INTER-SYSTEM HANDOVER COMMAND message	97
8.3.7.7	Reception of an INTER-SYSTEM HANDOVER FAILURE message by UTRAN	98
8.3.8	Inter-system cell reselection to UTRAN	98
8.3.8.1	General.....	98
8.3.8.2	Initiation.....	98
8.3.8.3	UE fails to complete an inter-system cell reselection	98
8.3.9	Inter-system cell reselection from UTRAN.....	98
8.3.9.1	General.....	98
8.3.9.2	Initiation.....	98
8.3.9.3	Successful cell reselection	99
8.3.9.4	Expiry of timer T309	99
8.4	Measurement procedures	99
8.4.1	Measurement control.....	101
8.4.1.1	General.....	101

8.4.1.2	Initiation.....	101
8.4.1.3	Reception of MEASUREMENT CONTROL by the UE.....	101
8.4.1.4	Unsupported measurement in the UE.....	102
8.4.1.5	Invalid MEASUREMENT CONTROL message.....	103
8.4.1.6	Reception of the MEASUREMENT CONTROL FAILURE message by the UTRAN.....	103
8.4.1.7	Measurements after transition from CELL_DCH to CELL_FACH state.....	103
8.4.1.8	Measurements after transition from CELL_FACH to CELL_DCH state.....	104
8.4.1.9	Measurements after transition from idle mode to CELL_DCH state.....	105
8.4.1.10	Measurements after transition from idle mode to CELL_FACH state.....	106
8.4.1.11	Measurements when measurement object is no longer valid.....	106
8.4.2	Measurement report.....	107
8.4.2.1	General.....	107
8.4.2.2	Initiation.....	107
8.4.2.3	Reception of a MEASUREMENT REPORT message by the UTRAN.....	108
8.5	General procedures.....	108
8.5.1	Selection of initial UE identity.....	108
8.5.2	Actions when entering idle mode from connected mode.....	108
8.5.3	Open loop power control upon establishment of DPCH.....	108
8.5.4	Physical channel establishment criteria.....	109
8.5.5	Detection of out of service area.....	109
8.5.6	Radio link failure criteria.....	110
8.5.7	Generic state transition rules depending on received information elements.....	110
8.5.8	Open loop power control.....	111
8.5.9	Detection of in service area.....	112
8.5.10	Hyper Frame Numbers.....	112
8.5.11	START.....	112
8.5.12	Integrity protection.....	113
8.5.12.1	Integrity protection in downlink.....	113
8.5.12.2	Integrity protection in uplink.....	114
8.5.12.3	Calculation of message authentication code.....	114
8.5.13	Measurement occasion calculation.....	114
8.5.14	Establishment of Access Service Classes.....	115
8.5.15	Mapping of Access Classes to Access Service Classes.....	115
8.5.16	PLMN Type Selection.....	116
8.5.17	CFN calculation.....	116
8.5.17.1	Initialization in CELL_DCH state on transiting from CELL_FACH state.....	116
8.5.17.2	Initialization in CELL_DCH state at hard handover.....	116
8.5.17.3	Initialization for CELL_FACH.....	117
8.6	Generic actions on receipt of an information element.....	117
8.6.1	CN information elements.....	117
8.6.1.1	CN domain specific DRX cycle length coefficient.....	117
8.6.1.2	NAS system information.....	117
8.6.2	UTRAN mobility information elements.....	117
8.6.2.1	URA identity.....	117
8.6.3	UE information elements.....	118
8.6.3.1	Activation time.....	118
8.6.3.2	UTRAN DRX Cycle length coefficient.....	118
8.6.3.3	DRX Indicator RRC State Indicator.....	119
8.6.3.4	Ciphering mode info.....	119
8.6.3.5	Integrity protection mode info.....	120
8.6.3.6	Configuration of CTCH occasions.....	120
8.6.3.7	UL Timing Advance.....	121
8.6.3.8	Integrity check info.....	121
8.6.3.9	New C-RNTI.....	121
8.6.4	Radio bearer information elements.....	121
8.6.4.1	RB mapping info.....	122
8.6.4.2	RLC Info.....	122
8.6.4.3	PDCP Info.....	122
8.6.5	Transport channel information elements.....	122
8.6.5.1	Transport Format Set.....	123
8.6.5.2	Transport format combination set.....	123
8.6.5.3	Transport format combination subset.....	124

8.6.6	Physical channel information elements	124
8.6.6.1	Frequency info	124
8.6.6.2	PRACH info and PRACH selection	124
8.6.6.3	Selection of RACH TTI	125
8.6.6.4	Secondary CCPCH info	125
8.6.6.5	Uplink DPCH info	126
8.6.6.6	Downlink DPCH info	126
8.6.6.7	Maximum allowed UL TX power	127
8.6.6.8	PDSCH with SHO DCH Info (FDD only)	127
8.6.6.9	PDSCH code mapping (FDD only)	127
8.6.6.10	Uplink DPCH power control info	127
8.6.6.11	Secondary CPICH info	128
8.6.6.12	Primary CPICH usage for channel estimation	128
8.6.6.13	DPCH frame offset	128
8.6.6.14	DPCH Compressed mode info	128
8.6.6.15	Repetition period, Repetition length, Offset	129
8.6.6.16	Primary CCPCH info	129
8.6.6.17	Primary CPICH info	129
8.6.6.18	CPCH SET Info (FDD only)	130
8.6.6.19	CPCH set ID (FDD only)	130
8.6.6.20	Default DPCH Offset Value	130
8.6.6.21	Secondary Scrambling Code, Code Number	131
8.6.7	Measurement information elements	131
8.6.7.1	Measurement validity	131
8.6.7.2	Filter coefficient	131
8.6.7.3	Intra-frequency/Inter-frequency/Inter-system cell info list	132
8.6.7.4	Inter-system measurement quantity	132
8.6.7.5	Cell Reporting Quantities	132
8.6.7.6	Reporting Cell Status	132
8.6.8	Other information elements	133
8.6.8.1	RAB NAS Synchronization Indicator	133
9	Protocol states	Error! Bookmark not defined.
9.1	RRC States and State Transitions including GSM	Error! Bookmark not defined.
9.2	Transition from Idle Mode to UTRAN Connected Mode	Error! Bookmark not defined.
9.2.1	Transitions for Emergency Calls	Error! Bookmark not defined.
9.3	UTRAN Connected Mode States and Transitions	Error! Bookmark not defined.
9.3.1	CELL_DCH state	Error! Bookmark not defined.
9.3.1.1	Transition from CELL_DCH to Idle Mode	Error! Bookmark not defined.
9.3.1.2	Transition from CELL_DCH to CELL_FACH state	Error! Bookmark not defined.
9.3.1.3	Transition from CELL_DCH to CELL_PCH state	Error! Bookmark not defined.
9.3.1.4	Transition from CELL_DCH to URA_PCH state	Error! Bookmark not defined.
9.3.1.5	Radio Resource Allocation tasks (CELL_DCH)	Error! Bookmark not defined.
9.3.1.6	RRC Connection mobility tasks (CELL_DCH)	Error! Bookmark not defined.
9.3.1.7	UE Measurements (CELL_DCH)	Error! Bookmark not defined.
9.3.1.8	Acquisition of system information (CELL_DCH)	Error! Bookmark not defined.
9.3.2	CELL_FACH state	Error! Bookmark not defined.
9.3.2.1	Transition from CELL_FACH to CELL_DCH state	Error! Bookmark not defined.
9.3.2.2	Transition from CELL_FACH to CELL_PCH state	Error! Bookmark not defined.
9.3.2.3	Transition from CELL_FACH to Idle Mode	Error! Bookmark not defined.
9.3.2.4	Transition from CELL_FACH to URA_PCH State	Error! Bookmark not defined.
9.3.2.5	Radio Resource Allocation Tasks (CELL_FACH)	Error! Bookmark not defined.
9.3.2.6	RRC Connection mobility tasks (CELL_FACH)	Error! Bookmark not defined.
9.3.2.7	UE Measurements (CELL_FACH)	Error! Bookmark not defined.
9.3.2.8	Transfer and update of system information (CELL_FACH)	Error! Bookmark not defined.
9.3.3	CELL_PCH state	Error! Bookmark not defined.
9.3.3.1	Transition from CELL_PCH to CELL_FACH state	Error! Bookmark not defined.
9.3.3.2	Radio Resource Allocation Tasks (CELL_PCH)	Error! Bookmark not defined.
9.3.3.3	RRC Connection mobility tasks (CELL_PCH)	Error! Bookmark not defined.
9.3.3.4	UE Measurements (CELL_PCH)	Error! Bookmark not defined.
9.3.3.5	Transfer and update of system information (CELL_PCH)	Error! Bookmark not defined.
9.3.4	URA_PCH State	Error! Bookmark not defined.

9.3.4.1	Transition from URA_PCH State to CELL_FACH State (URA_PCH)	Error! Bookmark not defined.
9.3.4.2	Radio Resource Allocation Tasks (URA_PCH)	Error! Bookmark not defined.
9.3.4.3	RRC Connection mobility tasks (URA_PCH)	Error! Bookmark not defined.
9.3.4.4	UE Measurements (URA_PCH)	Error! Bookmark not defined.
9.3.4.5	Transfer and update of system information (URA_PCH)	Error! Bookmark not defined.
9.3.5	States and Transitions for Cell Reselection in URA_PCH, CELL_PCH, and CELL_FACH	Error! Bookmark not defined.
9.4	Inter-system handover with PSTN/ISDN domain services	Error! Bookmark not defined.
9.5	Inter-system handover with IP domain services	Error! Bookmark not defined.
9.6	Inter-system handover with simultaneous IP and PSTN/ISDN domain services	Error! Bookmark not defined.
9.6.1	Inter-system handover UTRAN to GSM / BSS	Error! Bookmark not defined.
9.6.2	Inter-system handover GSM / BSS to UTRAN	Error! Bookmark not defined.
10	Message and information element functional definition and content	134
10.1	General	134
10.1.1	Protocol extensions	135
10.1.1.1	Extension of an information element with additional values or choices	135
10.1.1.2	Extension of a message with additional information elements	135
10.2	Radio Resource Control messages	137
10.2.1	ACTIVE SET UPDATE	137
10.2.2	ACTIVE SET UPDATE COMPLETE	139
10.2.3	ACTIVE SET UPDATE FAILURE	139
10.2.4	CELL UPDATE	140
10.2.5	CELL UPDATE CONFIRM	142
10.2.6	COUNTER CHECK	143
10.2.7	COUNTER CHECK RESPONSE	144
10.2.8	DOWNLINK DIRECT TRANSFER	144
10.2.9	DOWNLINK OUTER LOOP CONTROL	145
10.2.10	HANDOVER TO UTRAN COMMAND	145
10.2.11	HANDOVER TO UTRAN COMPLETE	148
10.2.12	INITIAL DIRECT TRANSFER	148
10.2.13	INTER-SYSTEM HANDOVER COMMAND	149
10.2.14	INTER-SYSTEM HANDOVER FAILURE	150
10.2.15	MEASUREMENT CONTROL	150
10.2.16	MEASUREMENT CONTROL FAILURE	152
10.2.17	MEASUREMENT REPORT	152
10.2.18	PAGING TYPE 1	153
10.2.19	PAGING TYPE 2	154
10.2.20	PHYSICAL CHANNEL RECONFIGURATION	155
10.2.21	PHYSICAL CHANNEL RECONFIGURATION COMPLETE	156
10.2.22	PHYSICAL CHANNEL RECONFIGURATION FAILURE	157
10.2.23	PHYSICAL SHARED CHANNEL ALLOCATION	158
10.2.24	PUSCH CAPACITY REQUEST	160
10.2.25	RADIO BEARER RECONFIGURATION	161
10.2.26	RADIO BEARER RECONFIGURATION COMPLETE	164
10.2.27	RADIO BEARER RECONFIGURATION FAILURE	164
10.2.28	RADIO BEARER RELEASE	165
10.2.29	RADIO BEARER RELEASE COMPLETE	168
10.2.30	RADIO BEARER RELEASE FAILURE	169
10.2.31	RADIO BEARER SETUP	170
10.2.32	RADIO BEARER SETUP COMPLETE	173
10.2.33	RADIO BEARER SETUP FAILURE	174
10.2.34	RRC CONNECTION RE-ESTABLISHMENT	175
10.2.35	RRC CONNECTION RE-ESTABLISHMENT COMPLETE	178
10.2.36	RRC CONNECTION RE-ESTABLISHMENT REQUEST	179
10.2.37	RRC CONNECTION REJECT	180
10.2.38	RRC CONNECTION RELEASE	181
10.2.39	RRC CONNECTION RELEASE COMPLETE	181
10.2.40	RRC CONNECTION REQUEST	182
10.2.41	RRC CONNECTION SETUP	183
10.2.42	RRC CONNECTION SETUP COMPLETE	184
10.2.43	RRC STATUS	185
10.2.44	SECURITY MODE COMMAND	186

10.2.45	SECURITY MODE COMPLETE.....	186
10.2.46	SECURITY MODE FAILURE	187
10.2.47	SIGNALLING CONNECTION RELEASE.....	187
10.2.48	SIGNALLING CONNECTION RELEASE REQUEST.....	188
10.2.49	SYSTEM INFORMATION	189
10.2.49.1	First Segment	190
10.2.49.2	First Segment (short)	190
10.2.49.3	Subsequent Segment	190
10.2.49.4	Last Segment	191
10.2.49.5	Last Segment (short).....	191
10.2.49.6	Complete SIB	191
10.2.49.7	Complete SIB (short).....	192
10.2.49.8	System Information Blocks	192
10.2.49.8.1	Master Information Block	192
10.2.49.8.2	System Information Block type 1.....	193
10.2.49.8.3	System Information Block type 2.....	193
10.2.49.8.4	System Information Block type 3.....	194
10.2.49.8.5	System Information Block type 4.....	194
10.2.49.8.6	System Information Block type 5.....	195
10.2.49.8.7	System Information Block type 6.....	197
10.2.49.8.8	System Information Block type 7.....	198
10.2.49.8.9	System Information Block type 8.....	199
10.2.49.8.10	System Information Block type 9.....	200
10.2.49.8.11	System Information Block type 10.....	200
10.2.49.8.12	System Information Block type 11.....	201
10.2.49.8.13	System Information Block type 12.....	201
10.2.49.8.14	System Information Block type 13.....	201
10.2.49.8.14.1	System Information Block type 13.1	202
10.2.49.8.14.2	System Information Block type 13.2	202
10.2.49.8.14.3	System Information Block type 13.3	202
10.2.49.8.14.4	System Information Block type 13.4	203
10.2.49.8.15	System Information Block type 14.....	203
10.2.49.8.16	System Information Block type 15.....	203
10.2.49.8.16.1	System Information Block type 15.1	205
10.2.49.8.16.2	System Information Block type 15.2	206
10.2.49.8.16.3	System Information Block type 15.3	207
10.2.49.8.17	System Information Block type 16.....	208
10.2.49.8.18	System Information Block type 17.....	209
10.2.50	SYSTEM INFORMATION CHANGE INDICATION	210
10.2.51	TRANSPORT CHANNEL RECONFIGURATION.....	211
10.2.52	TRANSPORT CHANNEL RECONFIGURATION COMPLETE	213
10.2.53	TRANSPORT CHANNEL RECONFIGURATION FAILURE	214
10.2.54	TRANSPORT FORMAT COMBINATION CONTROL	215
10.2.55	TRANSPORT FORMAT COMBINATION CONTROL FAILURE	216
10.2.56	UE CAPABILITY ENQUIRY	217
10.2.57	UE CAPABILITY INFORMATION	217
10.2.58	UE CAPABILITY INFORMATION CONFIRM.....	217
10.2.59	UPLINK DIRECT TRANSFER.....	218
10.2.60	UPLINK PHYSICAL CHANNEL CONTROL	218
10.2.61	URA UPDATE.....	219
10.2.62	URA UPDATE CONFIRM.....	221
10.2.63	UTRAN MOBILITY INFORMATION	222
10.2.64	UTRAN MOBILITY INFORMATION CONFIRM.....	222
10.2.65	UTRAN MOBILITY INFORMATION FAILURE	223
10.3	Information element functional definitions.....	224
10.3.1	CN Information elements	224
10.3.1.1	CN domain identity.....	224
10.3.1.2	CN Domain System Information	224
10.3.1.3	CN Information info	224
10.3.1.4	Flow Identifier	225
10.3.1.5	IMEI	225
10.3.1.6	IMSI (GSM-MAP).....	225

10.3.1.7	Location Area Identification	225
10.3.1.8	NAS message	225
10.3.1.9	NAS system information (GSM-MAP)	225
10.3.1.10	Paging record Type identifier	226
10.3.1.11	PLMN identity	226
10.3.1.12	PLMN Type	226
10.3.1.13	P-TMSI (GSM-MAP)	226
10.3.1.14	RAB identity	226
10.3.1.15	Routing Area Code	227
10.3.1.16	Routing Area Identification	227
10.3.1.17	Service Descriptor	227
10.3.1.18	TMSI (GSM-MAP)	227
10.3.2	UTRAN mobility Information elements	228
10.3.2.1	Cell Access Restriction	228
10.3.2.2	Cell identity	228
10.3.2.3	Cell selection and re-selection info for SIB3/4	229
10.3.2.4	Cell selection and re-selection info for SIB11/12	231
10.3.2.5	Mapping Info	232
10.3.2.6	URA identity	232
10.3.3	UE Information elements	233
10.3.3.1	Activation time	233
10.3.3.2	Capability Update Requirement	233
10.3.3.3	Cell update cause	233
10.3.3.4	Ciphering Algorithm	234
10.3.3.5	Ciphering mode info	234
10.3.3.6	CN domain specific DRX cycle length coefficient	234
10.3.3.7	CPCH Parameters	234
10.3.3.8	C-RNTI	236
10.3.3.9	DRAC system information	236
10.3.3.10	DRX Indicator RRC State Indicator	236
10.3.3.11	Establishment cause	236
10.3.3.12	Failure cause and error information	238
10.3.3.13	Initial UE identity	238
10.3.3.14	Integrity check info	239
10.3.3.15	Integrity protection activation info	240
10.3.3.16	Integrity protection Algorithm	240
10.3.3.17	Integrity protection mode info	240
10.3.3.18	LCS capability	241
10.3.3.19	Maximum bit rate	241
10.3.3.20	Measurement capability	241
10.3.3.21	Number of RRC Message Transmissions	243
10.3.3.22	Paging cause	243
10.3.3.23	Paging record	244
10.3.3.24	PDCP capability	244
10.3.3.25	Physical channel capability	245
10.3.3.26	Protocol error cause	246
10.3.3.27	Protocol error indicator	246
10.3.3.28	Redirection info	246
10.3.3.29	Re-establishment timer	247
10.3.3.30	Rejection cause	247
10.3.3.31	Release cause	247
10.3.3.32	RF capability	248
10.3.3.33	RLC capability	248
10.3.3.34	RLC reset indicator	248
10.3.3.35	Security capability	249
10.3.3.36	START	249
10.3.3.37	Transmission probability	249
10.3.3.38	Transport channel capability	250
10.3.3.39	UE multi-mode/multi-RAT capability	251
10.3.3.40	UE radio access capability	252
10.3.3.41	UE Timers and Constants in CELL_DCH	252
10.3.3.42	UE Timers and Constants in connected mode	253

10.3.3.43	UE Timers and Constants in idle mode	256
10.3.3.44	URA update cause	256
10.3.3.45	U-RNTI.....	256
10.3.3.46	U-RNTI Short	256
10.3.3.47	UTRAN DRX cycle length coefficient.....	257
10.3.3.48	Wait time	257
10.3.4	Radio Bearer Information elements.....	257
10.3.4.1	Downlink RLC STATUS info	257
10.3.4.2	PDCP info.....	258
10.3.4.3	PDCP SN info.....	259
10.3.4.4	Polling info	259
10.3.4.5	Predefined configuration identity	259
10.3.4.6	Predefined configuration value tag.....	260
10.3.4.7	Predefined RB configuration	260
10.3.4.8	RAB info.....	260
10.3.4.9	RAB info short.....	260
10.3.4.10	RAB information for setup	261
10.3.4.11	RAB information to reconfigure	261
10.3.4.12	RAB NAS Synchronization info.....	261
10.3.4.13	RB activation time info.....	261
10.3.4.14	RB COUNT-C MSB information	261
10.3.4.15	RB COUNT-C information	262
10.3.4.16	RB identity.....	262
10.3.4.17	RB information to be affected	262
10.3.4.18	RB information to reconfigure.....	263
10.3.4.19	RB information to release	263
10.3.4.20	RB information to setup.....	263
10.3.4.21	RB mapping info.....	264
10.3.4.22	RB with PDCP information	265
10.3.4.23	RLC info.....	266
10.3.4.24	Signalling RB information to setup	267
10.3.4.25	Transmission RLC Discard.....	268
10.3.5	Transport CH Information elements.....	269
10.3.5.1	Added or Reconfigured DL TrCH information	269
10.3.5.2	Added or Reconfigured UL TrCH information	270
10.3.5.3	CPCH set ID	270
10.3.5.4	Deleted DL TrCH information	270
10.3.5.5	Deleted UL TrCH information	270
10.3.5.6	DL Transport channel information common for all transport channels.....	271
10.3.5.7	DRAC Static Information	271
10.3.5.8	Power Offset Information	272
10.3.5.9	Predefined TrCH configuration	272
10.3.5.10	Quality Target.....	273
10.3.5.11	Semi-static Transport Format Information	273
10.3.5.12	TFCI Field 2 Information	274
10.3.5.13	TFCS Explicit Configuration.....	275
10.3.5.14	TFCS Information for DSCH (TFCI range method).....	276
10.3.5.15	TFCS Reconfiguration/Addition Information.....	276
10.3.5.16	TFCS Removal Information	278
10.3.5.17	Transparent mode signalling info	278
10.3.5.18	Transport channel identity	278
10.3.5.19	Transport Format Combination (TFC).....	279
10.3.5.20	Transport Format Combination Set	279
10.3.5.21	Transport Format Combination Set Identity	280
10.3.5.22	Transport Format Combination Subset.....	281
10.3.5.23	Transport Format Set	282
10.3.5.24	UL Transport channel information common for all transport channels.....	283
10.3.6	Physical CH Information elements.....	284
10.3.6.1	AC-to-ASC mapping	284
10.3.6.2	AICH Info.....	284
10.3.6.3	AICH Power offset	284
10.3.6.4	Allocation period info.....	284

10.3.6.5	ASC setting.....	285
10.3.6.6	Block STTD indicator.....	285
10.3.6.7	CCTrCH power control info.....	285
10.3.6.8	Cell parameters Id.....	285
10.3.6.9	Common timeslot info.....	286
10.3.6.10	Constant value.....	286
10.3.6.11	CPCH persistence levels.....	286
10.3.6.12	CPCH set info.....	287
10.3.6.13	CPCH Status Indication mode.....	289
10.3.6.13.1	PCPCH Availability (PA) mode.....	289
10.3.6.13.2	PCPCH Availability with Minimum Available Spreading Factor (PAMASF) mode.....	290
10.3.6.14	CSICH Power offset.....	291
10.3.6.15	Default DPCH Offset Value.....	291
10.3.6.16	Downlink channelization codes.....	292
10.3.6.17	Downlink DPCH info common for all RL.....	292
10.3.6.18	Downlink DPCH info common for all RL Post.....	293
10.3.6.19	Downlink DPCH info common for all RL Pre.....	294
10.3.6.20	Downlink DPCH info for each RL.....	295
10.3.6.21	Downlink DPCH info for each RL Post.....	296
10.3.6.22	Downlink DPCH power control information.....	296
10.3.6.23	Downlink information common for all radio links.....	296
10.3.6.24	Downlink information common for all radio links Post.....	297
10.3.6.25	Downlink information common for all radio links Pre.....	297
10.3.6.26	Downlink information for each radio link.....	298
10.3.6.27	Downlink information for each radio link Post.....	298
10.3.6.28	Downlink Outer Loop Control.....	298
10.3.6.29	Downlink PDSCH information.....	299
10.3.6.30	Downlink rate matching restriction information.....	299
10.3.6.31	Downlink Timeslots and Codes.....	299
10.3.6.32	DPCH compressed mode info.....	300
10.3.6.33	DPCH Compressed Mode Status Info.....	303
10.3.6.34	Dynamic persistence level.....	303
10.3.6.35	Frequency info.....	304
10.3.6.36	Individual timeslot info.....	304
10.3.6.37	Individual Timeslot interference.....	304
10.3.6.38	Maximum allowed UL TX power.....	304
10.3.6.39	Midamble configuration.....	304
10.3.6.40	Midamble shift and burst type.....	305
10.3.6.41	PDSCH Capacity Allocation info.....	306
10.3.6.42	PDSCH code mapping.....	307
10.3.6.43	PDSCH info.....	310
10.3.6.44	PDSCH Power Control info.....	310
10.3.6.45	PDSCH system information.....	310
10.3.6.46	PDSCH with SHO DCH Info.....	311
10.3.6.47	Persistence scaling factors.....	311
10.3.6.48	PICH Info.....	312
10.3.6.49	PICH Power offset.....	312
10.3.6.50	PRACH Channelization Code.....	313
10.3.6.51	PRACH info (for RACH).....	314
10.3.6.52	PRACH partitioning.....	314
10.3.6.53	PRACH power offset.....	316
10.3.6.54	PRACH system information list.....	317
10.3.6.55	Predefined PhyCH configuration.....	318
10.3.6.56	Primary CCPCH info.....	318
10.3.6.57	Primary CCPCH info post.....	318
10.3.6.58	Primary CCPCH TX Power.....	319
10.3.6.59	Primary CPICH info.....	319
10.3.6.60	Primary CPICH Tx power.....	319
10.3.6.61	Primary CPICH usage for channel estimation.....	319
10.3.6.62	PUSCH info.....	319
10.3.6.63	PUSCH Capacity Allocation info.....	320
10.3.6.64	PUSCH power control info.....	320

10.3.6.65	PUSCH system information.....	320
10.3.6.66	RACH transmission parameters.....	321
10.3.6.67	Radio link addition information.....	321
10.3.6.68	Radio link removal information.....	321
10.3.6.69	SCCPCH Information for FACH.....	322
10.3.6.70	Secondary CCPCH info.....	323
10.3.6.71	Secondary CCPCH system information.....	324
10.3.6.72	Secondary CPICH info	324
10.3.6.73	Secondary scrambling code	324
10.3.6.74	SFN Time info	325
10.3.6.75	SSDT cell identity.....	325
10.3.6.76	SSDT information.....	325
10.3.6.77	STTD indicator	325
10.3.6.78	TFC Control duration	326
10.3.6.79	TFCI Combining Indicator	326
10.3.6.80	TGPSI.....	326
10.3.6.81	Time info	326
10.3.6.82	Timeslot number.....	326
10.3.6.83	TPC combination index	327
10.3.6.84	TX Diversity Mode.....	327
10.3.6.85	UL interference.....	327
10.3.6.86	Uplink DPCH info.....	328
10.3.6.87	Uplink DPCH info Post	329
10.3.6.88	Uplink DPCH info Pre.....	329
10.3.6.89	Uplink DPCH power control info.....	329
10.3.6.90	Uplink DPCH power control info Post	330
10.3.6.91	Uplink DPCH power control info Pre.....	331
10.3.6.92	Uplink Timeslots and Codes.....	331
10.3.6.93	Uplink Timing Advance	332
10.3.6.94	Uplink Timing Advance Control	333
10.3.7	Measurement Information elements	333
10.3.7.1	Additional measurements list.....	333
10.3.7.2	Cell info	333
10.3.7.3	Cell measured results	334
10.3.7.4	Cell measurement event results	335
10.3.7.5	Cell reporting quantities.....	335
10.3.7.6	CFN-SFN observed time difference	336
10.3.7.7	Event results	337
10.3.7.8	FACH measurement occasion info	337
10.3.7.9	Filter coefficient.....	338
10.3.7.10	HCS Cell re-selection information.....	338
10.3.7.11	HCS neighbouring cell information.....	338
10.3.7.12	HCS Serving cell information.....	339
10.3.7.13	Inter-frequency cell info list	339
10.3.7.14	Inter-frequency event identity.....	339
10.3.7.15	Inter-frequency measured results list	340
10.3.7.16	Inter-frequency measurement	341
10.3.7.17	Inter-frequency measurement event results	341
10.3.7.18	Inter-frequency measurement quantity	342
10.3.7.19	Inter-frequency measurement reporting criteria.....	343
10.3.7.20	Inter-frequency measurement system information.....	344
10.3.7.21	Inter-frequency reporting quantity.....	344
10.3.7.22	Inter-frequency SET UPDATE.....	344
10.3.7.23	Inter-system cell info list	346
10.3.7.24	Inter-system event identity.....	346
10.3.7.25	Inter-system info.....	346
10.3.7.26	Inter-system measured results list.....	347
10.3.7.27	Inter-system measurement	347
10.3.7.28	Inter-system measurement event results	348
10.3.7.29	Inter-system measurement quantity	348
10.3.7.30	Inter-system measurement reporting criteria	349
10.3.7.31	Inter-system measurement system information	350

10.3.7.32	Inter-system reporting quantity.....	350
10.3.7.33	Intra-frequency cell info list	350
10.3.7.34	Intra-frequency event identity.....	351
10.3.7.35	Intra-frequency measured results list.....	351
10.3.7.36	Intra-frequency measurement	351
10.3.7.37	Intra-frequency measurement event results	352
10.3.7.38	Intra-frequency measurement quantity	352
10.3.7.39	Intra-frequency measurement reporting criteria.....	353
10.3.7.40	Intra-frequency measurement system information.....	355
10.3.7.41	Intra-frequency reporting quantity	355
10.3.7.42	Intra-frequency reporting quantity for RACH reporting.....	356
10.3.7.43	LCS Cipher GPS Data Indicator	356
10.3.7.44	LCS Error	357
10.3.7.45	LCS GPS acquisition assistance	357
10.3.7.46	LCS GPS almanac	358
10.3.7.47	LCS GPS assistance data	359
10.3.7.48	LCS GPS DGPS corrections.....	361
10.3.7.49	LCS GPS ionospheric model	362
10.3.7.50	LCS GPS measurement	362
10.3.7.51	LCS GPS navigation model.....	364
10.3.7.52	LCS GPS real-time integrity.....	366
10.3.7.53	LCS GPS reference time.....	366
10.3.7.54	LCS GPS UTC model.....	366
10.3.7.55	LCS IPDL parameters.....	367
10.3.7.56	LCS measured results	368
10.3.7.57	LCS measurement.....	368
10.3.7.58	LCS measurement event results.....	368
10.3.7.59	LCS multiple sets.....	369
10.3.7.60	LCS OTDOA assistance data	371
10.3.7.61	LCS OTDOA assistance for SIB	372
10.3.7.62	LCS OTDOA measurement.....	373
10.3.7.63	LCS OTDOA measurement assistance data	375
10.3.7.64	LCS OTDOA reference cell for assistance data	375
10.3.7.65	LCS position.....	376
10.3.7.66	LCS reporting criteria	377
10.3.7.67	LCS reporting quantity	377
10.3.7.68	Maximum number of reported cells on RACH.....	379
10.3.7.69	Measured results	379
10.3.7.70	Measured results on RACH	380
10.3.7.71	Measurement Command.....	381
10.3.7.72	Measurement control system information.....	381
10.3.7.73	Measurement Identity Number	381
10.3.7.74	Measurement reporting mode	382
10.3.7.75	Measurement Type	382
10.3.7.76	Measurement validity	382
10.3.7.77	Observed time difference to GSM cell	382
10.3.7.78	Periodical reporting criteria	383
10.3.7.79	Primary CCPCH RSCP info	383
10.3.7.80	Quality measured results list.....	383
10.3.7.81	Quality measurement	384
10.3.7.82	Quality measurement event results (FFS).....	384
10.3.7.83	Quality measurement reporting criteria	384
10.3.7.84	Quality reporting quantity.....	385
10.3.7.85	Reference time difference to cell	385
10.3.7.86	Reporting Cell Status.....	385
10.3.7.87	Reporting information for state CELL_DCH	387
10.3.7.88	SFN-SFN observed time difference.....	387
10.3.7.89	Time to trigger.....	387
10.3.7.90	Timeslot ISCP info	387
10.3.7.91	Traffic volume event identity	387
10.3.7.92	Traffic volume measured results list.....	388
10.3.7.93	Traffic volume measurement	389

10.3.7.94	Traffic volume measurement event results	389
10.3.7.95	Traffic volume measurement object	390
10.3.7.96	Traffic volume measurement quantity	390
10.3.7.97	Traffic volume measurement reporting criteria	391
10.3.7.98	Traffic volume measurement system information	392
10.3.7.99	Traffic volume reporting quantity	392
10.3.7.100	UE internal event identity	392
10.3.7.101	UE internal measured results	393
10.3.7.102	UE internal measurement	393
10.3.7.103	UE internal measurement event results	394
10.3.7.104	UE internal measurement quantity	394
10.3.7.105	UE internal measurement reporting criteria	395
10.3.7.106	UE internal measurement system information	395
10.3.7.107	UE Internal reporting quantity	396
10.3.7.108	UE Rx-Tx time difference	396
10.3.7.109	UE Transmitted Power info	396
10.3.8	Other Information elements	396
10.3.8.1	BCCH modification info	396
10.3.8.2	BSIC	396
10.3.8.3	CBS DRX Level 1 information	397
10.3.8.4	Cell Value tag	397
10.3.8.5	Inter-System handover failure	397
10.3.8.6	Inter-system message	397
10.3.8.7	MIB Value tag	398
10.3.8.8	PLMN Value tag	398
10.3.8.9	Predefined configuration identity and value tag	398
10.3.8.10	Protocol error information	399
10.3.8.11	References to other system information blocks	399
10.3.8.12	Scheduling information	400
10.3.8.13	SEG COUNT	401
10.3.8.14	Segment index	401
10.3.8.15	SIB data fixed	401
10.3.8.16	SIB data variable	401
10.3.8.17	SIB type	401
10.3.9	ANSI-41 Information elements	402
10.3.9.1	ANSI 41 Core Network Information	402
10.3.9.2	ANSI-41 Global Service Redirection information	402
10.3.9.3	ANSI-41 NAS parameter	403
10.3.9.4	ANSI-41 NAS system information	403
10.3.9.5	ANSI-41 Private Neighbor/Neighbour List information	403
10.3.9.6	ANSI-41 RAND information	403
10.3.9.7	ANSI-41 User Zone Identification information	403
10.3.9.8	MIN_P_REV	404
10.3.9.9	NID	404
10.3.9.10	P_REV	404
10.3.9.11	SID	404
10.3.10	Multiplicity values and type constraint values	404
11	Message and Information element abstract syntax (with ASN.1)	407
11.1	General message structure	Error! Bookmark not defined.
11.2	PDU definitions	Error! Bookmark not defined.
11.3	Information element definitions	Error! Bookmark not defined.
11.3.1	Core network information elements	Error! Bookmark not defined.
11.3.2	UTRAN mobility information elements	Error! Bookmark not defined.
11.3.3	User equipment information elements	Error! Bookmark not defined.
11.3.4	Radio bearer information elements	Error! Bookmark not defined.
11.3.5	Transport channel information elements	Error! Bookmark not defined.
11.3.6	Physical channel information elements	Error! Bookmark not defined.
11.3.7	Measurement information elements	Error! Bookmark not defined.
11.3.8	Other information elements	Error! Bookmark not defined.
11.3.9	ANSI-41 information elements	Error! Bookmark not defined.
11.4	Constant definitions	Error! Bookmark not defined.

11.5	RRC information between network nodes	Error! Bookmark not defined.
12	Message transfer syntax	408
12.1	Structure of encoded RRC messages	408
12.2	ECN link module for RRC	409
12.3	ECN modules for RRC	410
13	Protocol timers, counters and other parameters	410
13.1	Timers for UE	411
13.2	Counters for UE	412
13.3	UE constants and parameters	413
13.4	UE variables	413
13.4.1	CIPHERING_STATUS	413
13.4.2	COMPRESSED_MODE_ERROR	413
13.4.3	DEFAULT_TFC_SUBSET	414
13.4.4	DOFF	414
13.4.5	ESTABLISHED_RABS	414
13.4.6	INTEGRITY_PROTECTION_INFO	414
13.4.7	MEASUREMENT_IDENTITY	416
13.4.8	ORDERED_ASU	416
13.4.9	ORDERED_CONFIG	416
13.4.10	PROTOCOL_ERROR_INDICATOR	417
13.4.11	PROTOCOL_ERROR_INFORMATION	417
13.4.12	PROTOCOL_ERROR_REJECT	417
13.4.13	RB_UPLINK_CIPHERING_ACTIVATION_TIME_INFO	418
13.4.14	SELECTED_PLMN	418
13.4.15	TGPS_IDENTITY	418
13.4.16	UE_CAPABILITY_TRANSFERRED	418
13.4.17	VALUE_TAG	419
14	Specific functions	422
14.1	Intra-frequency measurements	422
14.1.1	Intra-frequency measurement quantities	422
14.1.2	Intra-frequency reporting events for FDD	422
14.1.2.1	Reporting event 1A: A Primary CPICH enters the reporting range	422
14.1.2.2	Reporting event 1B: A primary CPICH leaves the reporting range	423
14.1.2.3	Reporting event 1C: A non-active primary CPICH becomes better than an active primary CPICH ..	424
14.1.2.4	Reporting event 1D: Change of best cell	424
14.1.2.5	Reporting event 1E: A Primary CPICH becomes better than an absolute threshold	425
14.1.2.6	Reporting event 1F: A Primary CPICH becomes worse than an absolute threshold	425
14.1.3	Intra-frequency reporting events for TDD	426
14.1.3.1	Reporting event 1G: Change of best cell (TDD)	426
14.1.3.2	Reporting event 1H: Timeslot ISCP below a certain threshold (TDD)	426
14.1.3.3	Reporting event 1I: Timeslot ISCP above a certain threshold (TDD)	427
14.1.4	Event-triggered periodic intra-frequency measurement reports	427
14.1.4.1	Cell addition failure (FDD only)	427
14.1.4.2	Cell replacement failure (FDD only)	428
14.1.5	Mechanisms available for modifying intra-frequency measurement reporting behaviour	428
14.1.5.1	Hysteresis	428
14.1.5.2	Time-to-trigger	429
14.1.5.3	Cell individual offsets	430
14.1.5.4	Forbid a Primary CPICH to affect the reporting range (FDD only)	431
14.1.6	Report quantities	432
14.2	Inter-frequency measurements	432
14.2.1	Inter-frequency reporting events	433
14.2.1.1	Event 2a: Change of best frequency.	433
14.2.1.2	Event 2b: The estimated quality of the currently used frequency is below a certain threshold and the estimated quality of a non-used frequency is above a certain threshold.	433
14.2.1.3	Event 2c: The estimated quality of a non-used frequency is above a certain threshold	433
14.2.1.4	Event 2d: The estimated quality of the currently used frequency is below a certain threshold	433
14.2.1.5	Event 2e: The estimated quality of a non-used frequency is below a certain threshold	434
14.2.1.6	Event 2 f: The estimated quality of the currently used frequency is above a certain threshold	434
14.3	Inter-system measurements	434

14.3.1	Inter-System reporting events.....	434
14.3.1.1	Event 3a: The estimated quality of the currently used UTRAN frequency is below a certain threshold and the estimated quality of the other system is above a certain threshold.....	434
14.3.1.2	Event 3b: The estimated quality of other system is below a certain threshold.....	435
14.3.1.3	Event 3c: The estimated quality of other system is above a certain threshold.....	435
14.3.1.4	Event 3d: Change of best cell in other system.....	435
14.4	Traffic Volume Measurements.....	435
14.4.1	Traffic Volume Measurement Quantity.....	435
14.4.2	Traffic Volume reporting events.....	435
14.4.2.1	Reporting event 4 A: RLC buffer payload exceeds an absolute threshold.....	436
14.4.2.2	Reporting event 4 B: RLC buffer payload becomes smaller than an absolute threshold.....	436
14.4.3	Traffic volume reporting mechanisms.....	436
14.4.3.1	Pending time after trigger.....	437
14.4.4	Interruption of user data transmission.....	437
14.5	UE internal measurements.....	437
14.5.1	UE internal measurement quantities.....	437
14.5.2	UE internal measurement reporting events.....	438
14.5.2.1	Reporting event 6A: The UE Tx power becomes larger than an absolute threshold.....	438
14.5.2.2	Reporting event 6B: The UE Tx power becomes less than an absolute threshold.....	438
14.5.2.3	Reporting event 6C: The UE Tx power reaches its minimum value.....	438
14.5.2.4	Reporting event 6D: The UE Tx power reaches its maximum value.....	439
14.5.2.5	Reporting event 6E: The UE RSSI reaches the UE's dynamic receiver range.....	439
14.5.2.6	Reporting event 6F: The UE Rx-Tx time difference for a RL included in the active set becomes larger than an absolute threshold.....	439
14.5.2.7	Reporting event 6G: The UE Rx-Tx time difference for a RL included in the active set becomes less than an absolute threshold.....	439
14.6	Dynamic Resource Allocation Control of Uplink DCH (FDD only).....	440
14.7	Downlink power control.....	440
14.7.1	Generalities.....	440
14.7.2	Downlink power control in compressed mode.....	441
14.8	Calculated Transport Format Combination.....	442
14.9	UE autonomous update of active set on non-used frequency (FDD only).....	442
14.10	Provision and reception of RRC information between network nodes.....	443
14.10.1	RRC Information to target RNC.....	443
14.10.2	RRC information, target RNC to source RNC.....	449
14.10.3	RRC information, target RNC to source system.....	450
14.11	Versatile Channel Assignment Mode (VCAM) mapping rule (FDD only).....	450
14.12	LCS measurements.....	450
14.13	RRC information transferred between UE and other systems.....	451
14.13.1	RRC information, another RAT to UE.....	451
14.13.1.1	Pre-defined configuration information.....	451
14.13.2	RRC information, UE to another RAT.....	452
14.13.2.1	UE capability information.....	452
14.13.2.2	UE security information.....	452
14.13.2.3	Pre-defined configuration status information.....	452
15	Primitives between RRC and upper layers.....	452
16	Handling of unknown, unforeseen and erroneous protocol data.....	453
16.1	General.....	453
16.2	ASN.1 violation or encoding error.....	453
16.3	Unknown or unforeseen message type.....	453
16.4	Unknown or unforeseen information element value, mandatory information element.....	453
16.5	Conditional information element error.....	454
16.6	Unknown or unforeseen information element value, conditional information element.....	454
16.7	Unknown or unforeseen information element value, optional information element.....	455
16.8	Unexpected message extension.....	455
17	SDL.....	456
18	Appendices: Examples of operation.....	457
18.1	Example of VCAM mapping rule.....	457

Annex A (informative): USIM parameters	458
A.1 Introduction.....	458
A.2 Cipherring information.....	458
A.3 Frequency information.....	459
Neighbour cell list.....	459
A.4 Multiplicity values and type constraint values	459
Annex B (informative): Change history	460

Foreword

This Technical Specification (TS) has been produced by the 3rd Generation Partnership Project (3GPP).

The contents of the present document are subject to continuing work within the TSG and may change following formal TSG approval. Should the TSG modify the contents of the present document, it will be re-released by the TSG with an identifying change of release date and an increase in version number as follows:

Version x.y.z

where:

- x the first digit:
 - 1 presented to TSG for information;
 - 2 presented to TSG for approval;
 - 3 or greater indicates TSG approved document under change control.
- y the second digit is incremented for all changes of substance, i.e. technical enhancements, corrections, updates, etc.
- z the third digit is incremented when editorial only changes have been incorporated in the document.

1 Scope

The present document ~~describes~~ specifies the Radio Resource Control protocol for the UE-UTRAN radio interface.

The scope of this specification ~~contains also~~ includes:

- the information to be transported in a transparent container between source RNC and target RNC in connection ~~to~~ with SRNC relocation;
- the information to be transported in a transparent container between a target RNC and another system.

2 References

The following documents contain provisions which, through reference in this text, constitute provisions of the present document.

- References are either specific (identified by date of publication, edition number, version number, etc.) or non-specific.
- For a specific reference, subsequent revisions do not apply.
- For a non-specific reference, the latest version applies.

- [1] 3GPP TR 21.905: "Vocabulary for 3GPP Specifications".
- [2] 3GPP TS 25.301: "Radio Interface Protocol Architecture".
- [3] 3GPP TS 25.303: "Interlayer Procedures in Connected Mode".
- [4] 3GPP TS 25.304: "UE Procedures in Idle Mode and Procedures for Cell Reselection in Connected Mode".
- [5] 3GPP TS 24.008: "Mobile radio interface layer 3 specification, Core Network Protocols - Stage 3".
- [6] 3GPP TS 25.103: "RF Parameters in Support of RRM".
- [7] 3GPP TS 25.215: "Physical layer – Measurements (FDD)".
- [8] 3GPP TS 25.225: "Physical layer – Measurements (TDD)".
- [9] 3GPP TS 25.401: "UTRAN overall description".
- [10] 3GPP TS 25.402: "Synchronization in UTRAN, stage 2".
- [11] 3GPP TS 23.003: "Numbering, addressing and identification".
- [12] ICD-GPS-200: "Navstar GPS Space Segment/Navigation User Interface".
- [13] RTCM-SC104: "RTCM Recommended Standards for Differential GNSS Service (v.2.2)".
- [14] 3GPP TR 25.921: "Guidelines and Principles for protocol description and error handling".
- [15] 3GPP TS 25.321: "MAC protocol specification".
- [16] 3GPP TS 25.322: "RLC Protocol Specification".
- [17] 3GPP TS 24.007: "Mobile radio interface signalling layer 3 General Aspects".
- [18] 3GPP TS 25.305: "Stage 2 Functional Specification of Location Services in UTRAN".

3 Definitions and abbreviations

3.1 Definitions

For the purposes of the present document, the terms and definitions given in [1] apply.

3.2 Abbreviations

For the purposes of the present document, the following abbreviations apply:

ACK	Acknowledgement
AICH	Acquisition Indicator CHannel
AM	Acknowledged Mode
AS	Access Stratum
<u>ASC</u>	<u>Access Service Class</u>
ASN.1	Abstract Syntax Notation.1
BCCH	Broadcast Control Channel
BCFE	Broadcast Control Functional Entity
BER	Bit Error Rate
BLER	Block Error Rate
BSS	Base Station Sub-system
CH	Conditional on history
CV	Conditional on value
CCPCH	Common Control Physical CHannel
CCCH	Common Control Channel
CN	Core Network
CM	Connection Management
CPCH	Common Packet CHannel
C-RNTI	Cell RNTI
<u>CTCH</u>	<u>Common Traffic CHannel</u>
<u>CTFC</u>	<u>Calculated Transport Format Combination</u>
DCA	Dynamic Channel Allocation
DCCH	Dedicated Control Channel
DCFE	Dedicated Control Functional Entity
DCH	Dedicated Channel
DC-SAP	Dedicated Control SAP
<u>DGPS</u>	<u>Differential Global Positioning System</u>
DL	Downlink
DRAC	Dynamic Resource Allocation Control
DSCH	Downlink Shared Channel
DTCH	Dedicated Traffic Channel
FACH	Forward Access Channel
<u>FAUSCH</u>	<u>Fast Uplink Signalling Channel</u>
FDD	Frequency Division Duplex
FFS	For Further Study
GC-SAP	General Control SAP
HCS	Hierarchical Cell Structure
<u>HFN</u>	<u>Hyper Frame Number</u>
ID	Identifier
IETF	Internet Engineering Task Force
IMEI	International Mobile Equipment Identity
IMSI	International Mobile Subscriber Identity
IE	Information element
IP	Internet Protocol
ISCP	Interference on Signal Code Power
LAI	Location Area Identity
L1	Layer 1
L2	Layer 2
L3	Layer 3

MD	Mandatory default
MP	Mandatory present
MAC	Media Access Control
MCC	Mobile Country Code
MM	Mobility Management
MNC	Mobile Network Code
MS	Mobile Station
NAS	Non Access Stratum
Nt-SAP	Notification SAP
NW	Network
OP	Optional
ODMA	Opportunity Driven Multiple Access
PCCH	Paging Control Channel
PCH	Paging Channel
PDCP	Packet Data Convergence Protocol
PDSCH	Physical Downlink Shared Channel
PDU	Protocol Data Unit
PLMN	Public Land Mobile Network
PNFE	Paging and Notification Control Functional Entity
PRACH	Physical Random Access CHannel
P-TMSI	Packet Temporary Mobile Subscriber Identity
PUSCH	Physical Uplink Shared Channel
QoS	Quality of Service
RAB	Radio access bearer
RB	Radio Bearer
RAI	Routing Area Identity
RACH	Random Access CHannel
<u>RAT</u>	<u>Radio Access Technology</u>
RB	Radio Bearer
RFE	Routing Functional Entity
RL	Radio Link
RLC	Radio Link Control
RNTI	Radio Network Temporary Identifier
RNC	Radio Network Controller
RRC	Radio Resource Control
RSCP	Received Signal Code Power
RSSI	Received Signal Strength Indicator
SAP	Service Access Point
SCFE	Shared Control Function Entity
SF	Spreading Factor
SHCCH	Shared Control Channel
SIR	Signal to Interference Ratio
SSDT	Site Selection Diversity Transmission
S-RNTI	SRNC - RNTI
TDD	Time Division Duplex
TF	Transport Format
TFCS	Transport Format Combination Set
TFS	Transport Format Set
<u>TM</u>	<u>Transparent Mode</u>
TME	Transfer Mode Entity
TMSI	Temporary Mobile Subscriber Identity
Tr	Transparent
Tx	Transmission
UE	User Equipment
UL	Uplink
UM	Unacknowledged Mode
UMTS	Universal Mobile Telecommunications System
URA	UTRAN Registration Area
U-RNTI	UTRAN-RNTI
USCH	Uplink Shared Channel
UTRAN	UMTS <u>Universal</u> Terrestrial Radio Access Network

4 General

The functional entities of the RRC layer are described below:

- Routing of higher layer messages to different MM/CM entities (UE side) or different core network domains (UTRAN side) is handled by the Routing Function Entity (RFE)
- Broadcast functions are handled in the broadcast control function entity (BCFE). The BCFE is used to deliver the RRC services, which are required at the GC-SAP. The BCFE can use the lower layer services provided by the Tr-SAP and UM-SAP.
- Paging of UEs that do not have an RRC connection is controlled by the paging and notification control function entity (PNFE). The PNFE is used to deliver the RRC services that are required at the Nt-SAP. The PNFE can use the lower layer services provided by the Tr-SAP and UM-SAP.
- The Dedicated Control Function Entity (DCFE) handles all functions specific to one UE. The DCFE is used to deliver the RRC services which are required at the DC-SAP and can use lower layer services of UM/AM-SAP and Tr-SAP depending on the message to be sent and on the current UE service state.
- In TDD mode, the DCFE is assisted by the Shared Control Function Entity (SCFE) location in the C-RNC, which controls the allocation of the PDSCH and PUSCH using lower layers services of UM-SAP and Tr-SAP.
- The Transfer Mode Entity (TME) handles the mapping between the different entities inside the RRC layer and the SAPs provided by RLC.

NOTE: Logical information exchange is necessary also between the RRC sublayer functional entities. Most of that is implementation dependent and not necessary to present in detail in a specification.

Figure 1 shows the RRC model for the UE side and Figure 2 and Figure 3 show the RRC model for the UTRAN side.

NOTE: The figure shows only the types of SAPs that are used. Multiple instances of Tr-SAP, UM-SAP and AM-SAP are possible. Especially, different functional entities usually use different instances of SAP types.

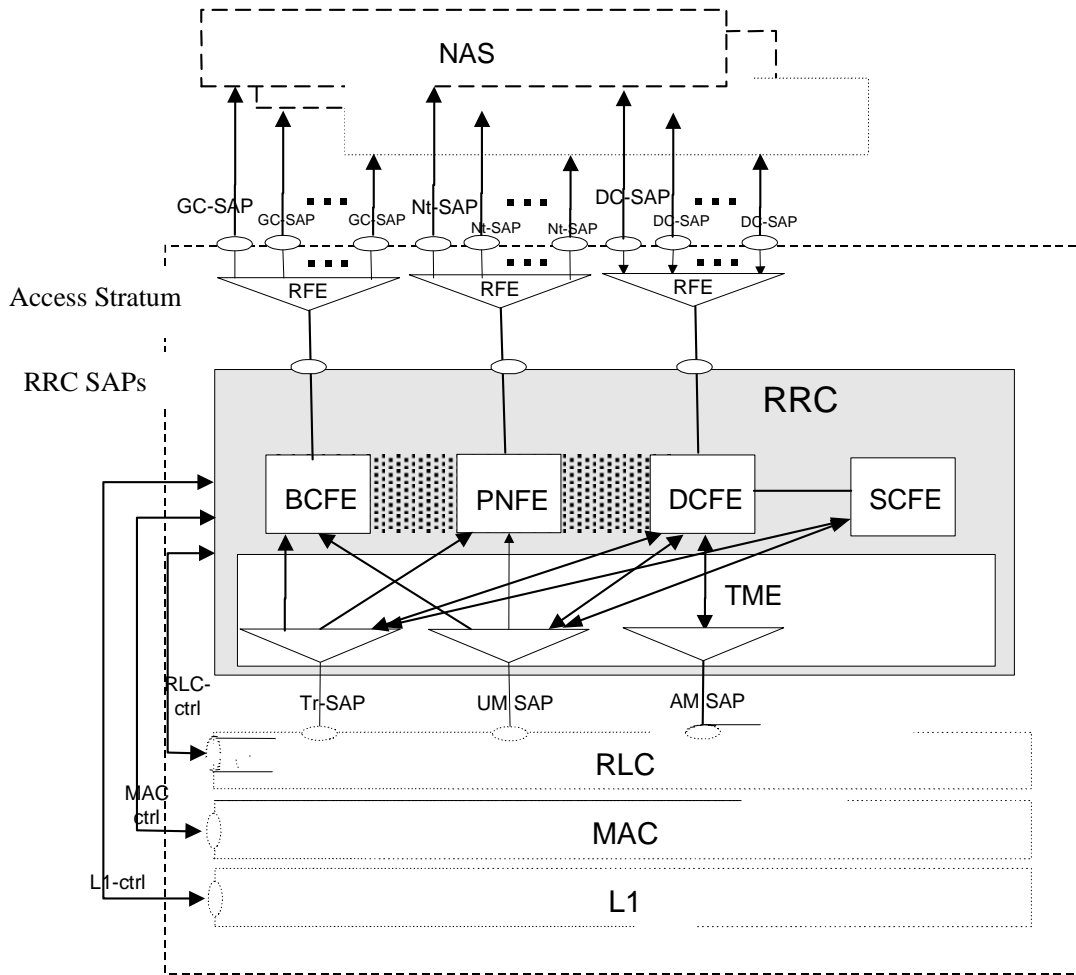

Figure 1: UE side model of RRC

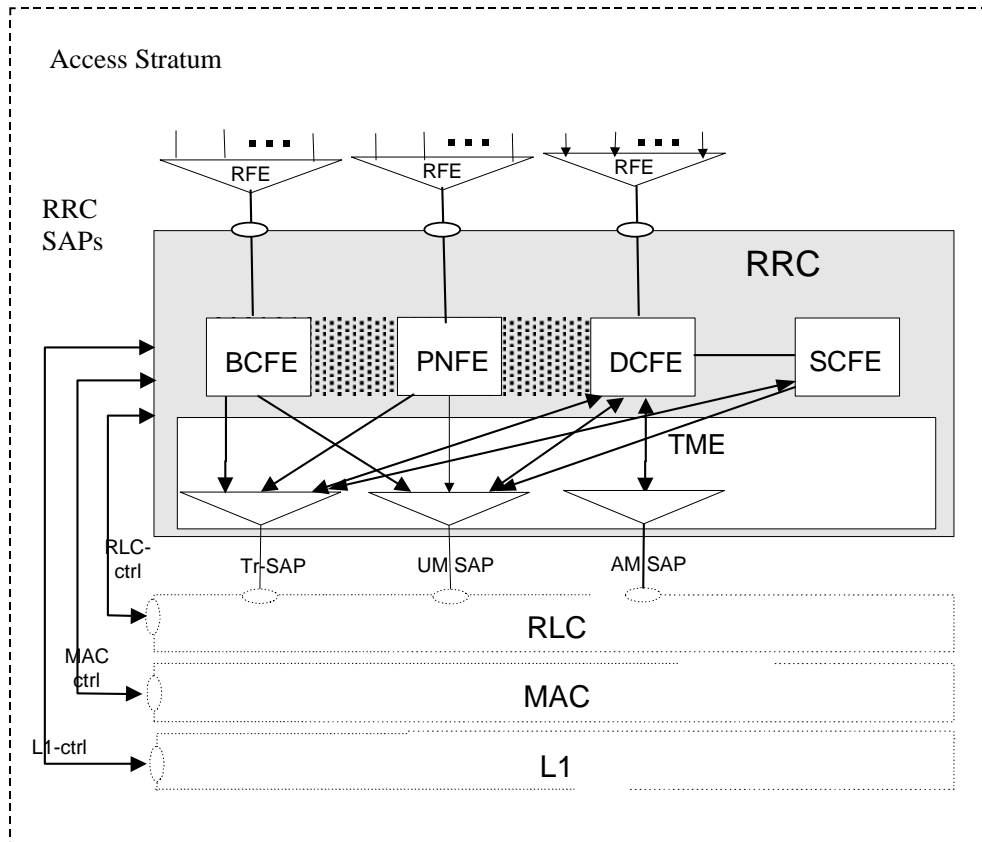

Figure 2: UTRAN side RRC model (DS-MAP system)

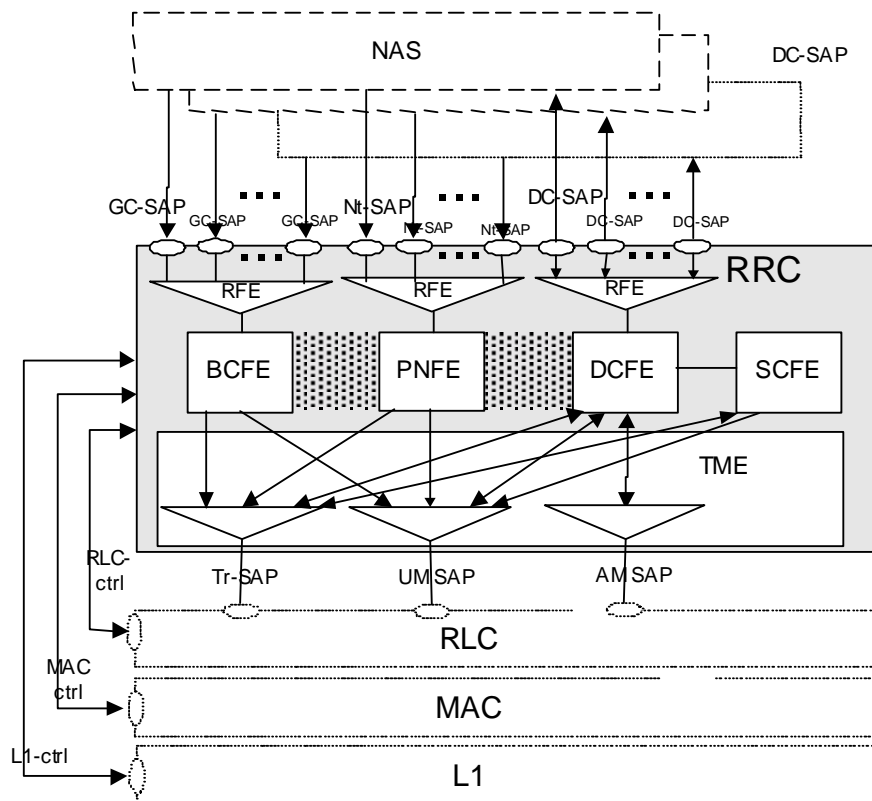

Figure 3: UTRAN side RRC model (DS-41 System)

5 RRC Services provided to upper layers

The RRC offers the following services to upper layers, a description and primitives of these services are provided in [2], [17].

- General Control;
- Notification;
- Dedicated control.

6 Services expected from lower layers

6.1 Services expected from Layer 2

The services provided by layer 2 are described in [2], [15] and [16].

6.2 Services expected from Layer 1

The services provided by layer 1 are described in [2].

7 Functions of RRC

The RRC performs the functions listed below. A more detailed description of these functions is provided in 3GPP TS 25.301:

- Broadcast of information provided by the non-access stratum (Core Network);
- Broadcast of information related to the access stratum;
- Establishment, maintenance and release of an RRC connection between the UE and UTRAN;
- Establishment, reconfiguration and release of Radio Bearers;
- Assignment, reconfiguration and release of radio resources for the RRC connection;
- RRC connection mobility functions;
- Routing of higher layer PDUs;
- Control of requested QoS;
- UE measurement reporting and control of the reporting;
- Outer loop power control;
- Control of ciphering;
- Slow DCA;
- Paging;
- Initial cell selection and re-selection;
- Arbitration of radio resources on uplink DCH;
- RRC message integrity protection;
- Timing advance (TDD mode);

- CBS control.

8 RRC procedures

On receiving a message the UE shall first apply integrity check as appropriate and then proceed with error handling as specified in clause 9 before continuing on with the procedure as specified in the relevant subclause. The RRC entity in the UE shall consider PDUs to have been transmitted when they are submitted to the lower layers. In the UE, timers ~~Timers~~ are started when the PDUs are sent on the radio interface in the case of the ~~Ue~~ transmission using the CCCH.

8.1 RRC Connection Management Procedures

8.1.2 Paging

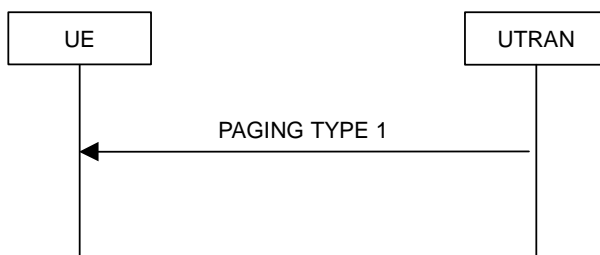

Figure 6: Paging

8.1.2.1 General

This procedure is used to transmit paging information to selected UEs in idle mode, CELL_PCH or URA_PCH state using the paging control channel (PCCH). Upper layers in the network may request paging, to e.g. establish a signalling connection. UTRAN may initiate paging in CELL_PCH or URA_PCH state, to trigger a UE state transition. In addition, UTRAN may initiate paging in idle mode, CELL_PCH and URA_PCH state to trigger reading of updated system information.

8.1.2.2 Initiation

UTRAN initiates the paging procedure by transmitting a PAGING TYPE 1 message on an appropriate paging occasion on the PCCH.

UTRAN may repeat transmission of a PAGING TYPE 1 message to a UE in several paging occasions to increase the probability of proper reception of a page.

UTRAN may page several UEs in the same paging occasion by including one IE "Paging record" for each UE in the PAGING TYPE 1 message. UTRAN may also indicate that system information has been updated, by including the value tag of the master information block in the IE "BCCH modification information" in the PAGING TYPE 1 message. In this case, UTRAN may omit the IEs "Paging record".

8.1.2.3 Reception of an PAGING TYPE 1 message by the UE

The UE shall in idle mode, CELL_PCH state and URA_PCH state receive the paging information for all its monitored paging occasions. For an UE in idle mode, the paging occasions are specified in TS 25.304 and depend on the IE "CN domain specific DRX cycle length coefficient", as specified in 8.6.1.1. For an UE in CELL_PCH state and URA_PCH state the paging occasions depend also on the IE "UTRAN DRX Cycle length coefficient" and the IE "~~DRX indicator~~RRC State Indicator", as specified in subclauses 8.6.3.2 and 8.6.3.3 respectively.

When the UE receives a PAGING TYPE 1 message, it shall check each occurrence of the IE "Paging record"

For each included paging record the UE shall compare the included identity with the identity of the UE according to the following:

An idle mode UE shall:

- if the IE "paging originator" is CN:
 - compare the included identities of type CN UE identity with all of its allocated CN UE identities;
- if at least one match is found:
 - forward the identity and paging cause to the upper layer entity indicated by the IE "CN domain identity";
- if the IE "paging originator" is UTRAN:
 - ignore that paging record.

A connected mode UE shall:

- if the IE "paging originator" is UTRAN:
 - compare the included identities of type "UTRAN originator" with its allocated U-RNTI;
- if at least one match is found:
 - perform a cell update procedure with cause "paging response" as specified in subclause 8.3.1.2;
- if the IE "paging originator" is CN:
 - ignore that paging record.

If the IE "BCCH modification info" is included, the UE shall perform the actions as specified in subclause 8.1.1.

8.1.3 RRC connection establishment

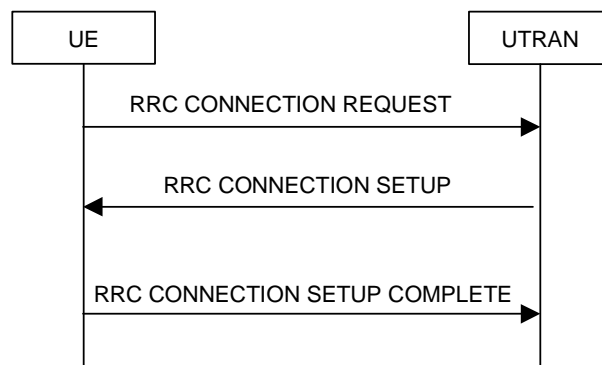

Figure 7: RRC Connection Establishment, network accepts RRC connection

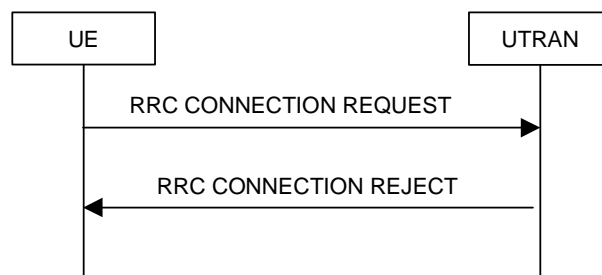

Figure 8: RRC Connection Establishment, network rejects RRC connection

8.1.3.1 General

The purpose of this procedure is to establish an RRC connection.

8.1.3.2 Initiation

The UE shall initiate the procedure when ~~the non-access stratum in the UE may request~~ the establishment of a signalling connection and the UE is in idle mode ~~at most one~~ (no RRC connection exists), as specified in subclause 8.1.8.

Upon initiation of the procedure, the UE shall:

- ~~perform the mapping of the Access Class to an Access Service Class as specified in subclause 8.5.15, and shall provide the necessary configuration information to the lower layers to be applied for accessing on the RACH~~
- set the variable `PROTOCOL_ERROR_INDICATOR` to FALSE;
- set the IE "Initial UE identity" in the variable `INITIAL_UE_IDENTITY` according to subclause 8.5.1;
- set the contents of the RRC CONNECTION REQUEST message according to subclause 8.1.3.2a;
- set CFN in relation to SFN of current cell according to 8.5.17; **Note to Hans: indentation changed to B1**
- ~~perform the mapping of the Access Class to an Access Service Class as specified in subclause 8.5.15, and apply the given Access Service Class when accessing the RACH;~~
- ~~transmit~~ ~~an~~ ~~submit~~ the RRC CONNECTION REQUEST message ~~for transmission on the uplink CCCH;~~
- reset counter V300, and;
- ~~start timer T300 when the MAC layer indicates success or failure to transmit the message;~~
- ~~perform the mapping of the Access Class to an Access Service Class as specified in subclause 8.5.15, and shall apply the given Access Service Class when accessing the RACH;~~

8.1.3.2a RRC CONNECTION REQUEST message contents to set

The UE shall, in the transmitted RRC CONNECTION REQUEST message:

- set the IE "Establishment cause" to the value of the variable `ESTABLISHMENT_CAUSE` reflecting the cause of establishment in the upper layers;
 - set the IE "Initial UE identity" to the value of the variable `INITIAL_UE_IDENTITY` according to subclause 8.5.1;
 - set the IE "Protocol error indicator" to the value of the variable `PROTOCOL_ERROR_INDICATOR`;
 - include a measurement report in the IE "Measured results on RACH", as specified in the IE "Intra-frequency reporting quantity for RACH reporting" and the IE "Maximum number of reported cells on RACH" in system information block type 11.
- ~~submit the RRC CONNECTION REQUEST message to the lower layers for transmission on the uplink CCCH;~~
- ~~reset counter V300 and start timer T300 when the RRC CONNECTION REQUEST message is sent on the radio interface.~~
- NOTE: what happens here if the transmission cannot succeed in lower layers (no positive AICH)?

8.1.3.3 Reception of an RRC CONNECTION REQUEST message by the UTRAN

Upon receiving an RRC CONNECTION REQUEST message, UTRAN should either:

- ~~transmits~~ ~~submit~~ an RRC CONNECTION SETUP message to the lower layers for transmission on the downlink CCCH; or
- ~~transmit~~ ~~submit~~ an RRC CONNECTION REJECT message on the downlink CCCH. In the RRC CONNECTION REJECT message, the UTRAN may direct the UE to another UTRA carrier or to another

system. After the RRC CONNECTION REJECT message has been sent, all context information for the UE may be deleted in UTRAN.

8.1.3.3a Cell re-selection or T300 timeout

If

- the UE has not yet received an RRC CONNECTION SETUP message with the value of the IE "Initial UE identity" equal to the value of the variable INITIAL_UE_IDENTITY, and;
- cell re-selection or expiry of timer T300 occurs;

the UE shall:

- check the value of V300, and:
 - if V300 is equal to or smaller than N300:
 - if cell re-selection occurred, set CFN in relation to SFN of current cell according to subclause 8.5.17;
 - set the IEs in the RRC CONNECTION REQUEST message according to subclause 8.1.3.2a;
 - perform the mapping of the Access Class to an Access Service Class as specified in subclause 8.5.15, and apply the given Access Service Class when accessing the RACH;
 - submit a new RRC CONNECTION REQUEST message to lower layers for transmission on the uplink CCCH;
 - increment counter V300;
 - restart timer T300 when the MAC layer indicates success or failure to transmit the message;
 - if V300 is greater than N300:
 - enter idle mode;:-
 - ~~The procedure ends and~~ a connection failure may be indicated to the non-access stratum;:-
 - ~~Other actions the UE shall perform when entering idle mode from connected mode are specified in~~ subclause 8.5.2;:-
 - ~~the procedure ends.~~

8.1.3.4 Reception of an RRC CONNECTION SETUP message by the UE

~~Hans, Identification has been changed in entire subclause 8.1.3.4 highlighted in magenta~~ The UE shall compare the value of the IE "Initial UE identity" in the received RRC CONNECTION SETUP message with the value of the variable INITIAL_UE_IDENTITY ~~IE "Initial UE identity" in the most recent RRC CONNECTION REQUEST message sent by the UE.~~

If the values are different, the UE shall:

- ignore the rest of the message;

If the values are identical, the UE shall:

- stop timer T300, and act upon all received information elements as specified in subclause 8.6, unless specified otherwise in the following:
 - store the value of the IE "New-U-RNTI";
 - initiate the signalling link parameters according to the IE "RB-mapping info";
 - if neither the IE "PRACH info (for RACH)", nor the IE "Uplink DPCH info" is included:
 - if the UE will be in the CELL_FACH state at the conclusion of this procedure:

- let the physical channel of type PRACH that is given in system information to be the default in uplink to which the RACH is mapped to;
- select PRACH according to subclause 8.6.6.2;
- select Secondary CCPCH according to subclause 8.6.6.4;
- if the contents of the variable C_RNTI is empty:
 - perform a cell update procedure according to subclause 8.3.1 and then continue with the procedure as indicated in the following;
- if neither the IE "Secondary CCPCH info", nor the IE "Downlink DPCH info" is included:
 - start to receive the physical channel of type Secondary CCPCH that is given in system information to be used as default by FACH;
- enter a state according to subclause 8.5.7;
- transmit ~~submit~~ an RRC CONNECTION SETUP COMPLETE message to the lower layers on the uplink DCCH after successful state transition per subclause 8.5.7, with the contents set as specified below:
 - set the IE "RRC transaction identifier" to
 - the value of "RRC transaction identifier" in the entry for the RRC CONNECTION SETUP message in the table "Accepted transactions" in the variable TRANSACTIONS, and;
 - clear that entry.
 - include ~~calculate~~ START [3GPP TS 33.102] values to be used in ciphering and integrity protection for each CN domain according to subclause 8.5.11 and include the result in the IE "START list";
 - if requested in the IE "Capability update requirement" sent in the RRC CONNECTION SETUP message:
 - include its UTRAN-specific capabilities in the IE "UE radio access capability";
 - if requested in the IE "Capability update requirement" sent in the RRC CONNECTION SETUP message:
 - include its inter-system capabilities in the IE "UE system specific capability".

When the successful delivery of the RRC CONNECTION SETUP COMPLETE message has been confirmed by RLC ~~submitted~~ to lower layers for transmission the UE shall:

- if the UE has entered CELL_FACH state:
 - start timer T305 if periodical cell update has been requested in system information block type 1;
- update its variable UE_CAPABILITY_TRANSFERRED which UE capabilities it has transmitted to the UTRAN;
- set the "Status" in the variable INTEGRITY_PROTECTION_INFO to "Not started";

and the procedure ends.

8.1.3.5 Physical channel failure or ~~or cell re-selection~~ T300 timeout

Upon expiry of timer T300 ~~or, if~~

- the UE failed to establish, per subclause 8.5.4, the physical channel(s) according to subclause 8.5.4 indicated in the RRC CONNECTION SETUP message, ~~or, the UE shall:~~
- the UE performs cell re-selection;
- after received an RRC CONNECTION SETUP message with the value of the IE "Initial UE identity" equal to the value of the variable INITIAL_UE_IDENTITY, and;
- before the RRC CONNECTION SETUP COMPLETE message is delivered to lower layers for transmission;

the UE shall:

- check the value of V300, and:
 - if V300 is equal to or smaller than N300:
 - set CFN in relation to SFN of current cell according to subclause 8.5.17;
 - set the IEs in the RRC CONNECTION REQUEST message according to subclause 8.1.3.2a;
 - perform the mapping of the Access Class to an Access Service Class as specified in subclause 8.5.15, and apply the given Access Service Class when accessing the RACH;
 - ~~transmit~~ submit a new RRC CONNECTION REQUEST message to the lower layers for transmission on the uplink CCCH;
 - increment counter V300, and ;
 - restart timer T300 when the MAC layer indicates success or failure to transmit the message;
 - ~~increase counter V300;~~
 - ~~set the IEs in the RRC CONNECTION REQUEST message according to subclause 8.1.3.2;~~
 - if V300 is greater than N300:
 - ~~enter idle mode. The procedure ends and a connection failure may be indicated to the non-access stratum. Other actions the UE shall perform when entering idle mode from connected mode are specified in subclause 8.5.2.~~
 - perform the actions specified in subclause 8.5.2 when entering idle mode from connected mode;
 - ~~The procedure ends and a connection failure may be indicated to the non-access stratum;~~
 - the procedure ends.

8.1.3.6 Invalid RRC CONNECTION SETUP message

If the UE receives an RRC CONNECTION SETUP message which contains an IE "Initial UE identity" with a value which is identical to the value of the variable INITIAL_UE_IDENTITY ~~IE "Initial UE identity" in the most recent RRC CONNECTION REQUEST message sent by the UE,~~ but the RRC CONNECTION SETUP message contains a protocol error causing the variable PROTOCOL_ERROR_REJECT to be set to TRUE according to clause 16, the UE shall perform procedure specific error handling as follows:

The UE shall check the value of V300, and

- if V300 is equal to or smaller than N300:
 - set the variable PROTOCOL_ERROR_INDICATOR to TRUE;
 - set the IEs in the RRC CONNECTION REQUEST message according to subclause 8.1.3.2a;
 - perform the mapping of the Access Class to an Access Service Class as specified in subclause 8.5.15, and apply the given Access Service Class when accessing the RACH;
 - ~~transmit~~ submit a new RRC CONNECTION REQUEST message to the lower layers for transmission on the uplink CCCH;
 - ~~set the variable PROTOCOL_ERROR_INDICATOR to TRUE;~~
 - increment counter V300, and;
 - restart timer T300 when the MAC layer indicates success or failure in ~~to~~ transmitting the message;
 - ~~increase counter V300;~~
 - ~~set the IEs in the RRC CONNECTION REQUEST message according to subclause 8.1.3.2;~~

- if V300 is greater than N300:
 - ~~enter idle mode, and the procedure ends and a connection failure may be indicated to the non-access stratum. Other actions the UE shall perform when entering idle mode from connected mode are specified in subclause 8.5.2.~~
 - perform the actions specified in subclause 8.5.2 when entering idle mode from connected mode;
 - ~~The procedure ends and a connection failure may be indicated to the non-access stratum;~~
 - the procedure ends.

8.1.3.7 Reception of an RRC CONNECTION REJECT message by the UE

When the UE receives an RRC CONNECTION REJECT message on the downlink CCCH, it shall compare the value of the IE "Initial UE identity" in the received RRC CONNECTION REJECT message with the value of the ~~IE "Initial UE identity" in the last RRC CONNECTION REQUEST message sent by the UE~~variable INITIAL_UE_IDENTITY:

If the values are different, the UE shall ignore the rest of the message;

If the values are identical, the UE shall stop timer T300 and:

- if the IE "wait time" \neq '0', and
 - if the IE "frequency info" is present and:
 - if V300 is equal to or smaller than N300:
 - initiate cell selection on the designated UTRA carrier;
 - after having selected and camped on a cell:
 - set CFN in relation to SFN of current cell according to subclause 8.5.17;
 - set the contents of the RRC CONNECTION REQUEST message according to subclause 8.1.3.2a;
 - perform the mapping of the Access Class to an Access Service Class as specified in subclause 8.5.15, and apply the given Access Service Class when accessing the RACH;
 - transmit an RRC CONNECTION REQUEST message on the uplink CCCH;
 - reset counter V300;
 - start timer T300 when the MAC layer indicates success or failure to transmit the message;~~re-initiate the RRC connection establishment procedure;~~
 - ~~delay/disable~~ cell reselection to original carrier until the time stated in the IE "wait time" has elapsed;
 - if a cell selection on the designated carrier fails:
 - wait for the time stated in the IE "wait time";
 - set CFN in relation to SFN of current cell according to subclause 8.5.17;
 - set the IEs in the RRC CONNECTION REQUEST message according to subclause 8.1.3.2a;
 - perform the mapping of the Access Class to an Access Service Class as specified in subclause 8.5.15, and apply the given Access Service Class when accessing the RACH;
 - ~~then transmit-submit~~ a new RRC CONNECTION REQUEST message to the lower layers for transmission on the uplink CCCH of the original serving cell;
 - increment counter V300; and
 - restart timer T300 when the MAC layer indicates success or failure to transmit the message~~when the new RRC CONNECTION REQUEST message is sent on the radio interface;~~

- ~~— increase counter V300;~~
 - ~~— set the IEs in the RRC CONNECTION REQUEST message according to subclause 8.1.3.2;~~
- if V300 is greater than N300:
 - ~~enter idle mode. The procedure ends and a connection failure may be indicated to the non-access stratum. Other actions the UE shall perform when entering idle mode from connected mode are specified in subclause 8.5.2.~~
 - ~~perform the actions specified in subclause 8.5.2 when entering idle mode from connected mode.;~~
 - ~~The procedure ends and a connection failure may be indicated to the non-access stratum.;~~
 - ~~the procedure ends.~~
- if the IE "inter-system info" is present and:
 - if V300 is equal to or smaller than N300:
 - perform cell selection in the designated system;
 - delay cell reselection to the original system until the time stated in the IE "wait time" has elapsed.
 - if cell selection in the designated system fails:
 - wait at least the time stated in the IE "wait time";
 - ~~set CFN in relation to SFN of current cell according to subclause 8.5.17;~~
 - ~~set the IEs in the RRC CONNECTION REQUEST message according to subclause 8.1.3.2.~~
 - ~~perform the mapping of the Access Class to an Access Service Class as specified in subclause 8.5.15, and apply the given Access Service Class when accessing the RACH;~~
 - ~~then transmit a new RRC CONNECTION REQUEST message to the lower layers for transmission on the uplink CCCH;~~
 - ~~increment counter V300; and~~
 - ~~restart timer T300 when the MAC layer indicates success or failure to transmit the message when the new RRC CONNECTION REQUEST message is sent on the radio interface.~~
 - ~~— increase counter V300;~~
 - ~~— set the IEs in the RRC CONNECTION REQUEST message according to subclause 8.1.3.2.~~
- if V300 is greater than N300:
 - ~~enter idle mode.;~~
 - ~~perform the actions specified in subclause 8.5.2 when entering idle mode from connected mode.;~~
 - ~~The procedure ends and a connection failure may be indicated to the non-access stratum.~~
 - ~~The procedure ends. The procedure ends and a connection failure may be indicated to the non-access stratum. Other actions the UE shall perform when entering idle mode from connected mode are specified in subclause 8.5.2;~~
- If neither the IEs "frequency info" nor "inter-system info" are present and:
 - if V300 is equal to or smaller than N300:
 - wait at least the time stated in the IE "wait time";
 - ~~set the IEs in the RRC CONNECTION REQUEST message according to subclause 8.1.3.2;~~

- ~~perform the mapping of the Access Class to an Access Service Class as specified in subclause 8.5.15, and apply the given Access Service Class when accessing the RACH;~~
- ~~transmit-submit a new RRC CONNECTION REQUEST message to the lower layers for transmission on the uplink CCCH;~~
- ~~increment counter V300 ;and~~
- ~~restart timer T300 when the MAC layer indicates success or failure to transmit the message when the new RRC CONNECTION REQUEST message is sent on the radio interface;~~
- ~~increase counter V300;~~
- ~~set the IEs in the RRC CONNECTION REQUEST message according to subclause 8.1.3.2;~~
- if V300 is greater than N300:
 - ~~enter idle mode;;~~
 - ~~perform the actions specified in subclause 8.5.2 when entering idle mode from connected mode;;~~
 - ~~The procedure ends and a connection failure may be indicated to the non-access stratum~~
 - ~~the procedure ends..The procedure ends and a connection failure may be indicated to the non-access stratum. Other actions the UE shall perform when entering idle mode from connected mode are specified in subclause 8.5.2;~~
- if the IE "wait time" = '0':
 - ~~enter idle mode;; The procedure ends and a connection failure may be indicated to the non-access stratum. Other actions the UE shall perform when entering idle mode from connected mode are specified in subclause 8.5.2.~~
 - ~~perform the actions specified in subclause 8.5.2 when entering idle mode from connected mode;;~~
 - ~~The procedure ends and a connection failure may be indicated to the non-access stratum;;~~
 - ~~the procedure ends.~~

8.1.3.8 Invalid RRC CONNECTION REJECT message

If the UE receives an RRC CONNECTION REJECT message which contains an IE "Initial UE identity" with a value which is identical to the value of the IE "Initial UE identity" in the most recent RRC CONNECTION REQUEST message sent by the UE; but the RRC CONNECTION REJECT message contains a protocol error causing the variable PROTOCOL_ERROR_REJECT to be set to TRUE according to clause 16, the UE shall perform procedure specific error handling as follows:

The UE shall:

- if the IE "wait time" is ≤ 0 , and:
 - if V300 is equal to or smaller than N300:
 - wait for the time stated in the IE "wait time";
 - ~~set the variable PROTOCOL_ERROR_INDICATOR to TRUE;~~
 - ~~set the IEs in the RRC CONNECTION REQUEST message according to subclause 8.1.3.2a;;except for the IE "Protocol error indicator" which shall be set to TRUE.~~
 - ~~perform the mapping of the Access Class to an Access Service Class as specified in subclause 8.5.15, and apply the given Access Service Class when accessing the RACH;~~
 - ~~transmit-submit a new RRC CONNECTION REQUEST message to the lower layers for transmission on the uplink CCCH, restart timer T300;~~
 - ~~increase-increment counter V300;and~~

- restart timer T300 when the MAC layer indicates success or failure to transmit the message when the new RRC CONNECTION REQUEST message is sent on the radio interface;
- set the IEs in the RRC CONNECTION REQUEST message according to subclause 8.1.3.2, except for the IE "Protocol error indicator" which shall be set to TRUE.
- if V300 is greater than N300:
 - enter idle mode; The procedure ends and a connection failure may be indicated to the non-access stratum. Other actions the UE shall perform when entering idle mode from connected mode are specified in subclause 8.5.2;
 - perform the actions specified in subclause 8.5.2 when entering idle mode from connected mode;
 - The procedure ends and a connection failure may be indicated to the non-access stratum;
 - the procedure ends.
- if the IE "wait time" is = 0:
 - enter idle mode; The procedure ends and a connection failure may be indicated to the non-access stratum. Other actions the UE shall perform when entering idle mode from connected mode are specified in subclause 8.5.2.
 - perform the actions specified in subclause 8.5.2 when entering idle mode from connected mode;
 - The procedure ends and a connection failure may be indicated to the non-access stratum;
 - the procedure ends.

8.1.3.9 Reception of an RRC CONNECTION SETUP COMPLETE message by the UTRAN

When UTRAN has received the RRC CONNECTION SETUP COMPLETE message, the procedure ends on the UTRAN side.

8.1.4 RRC connection release

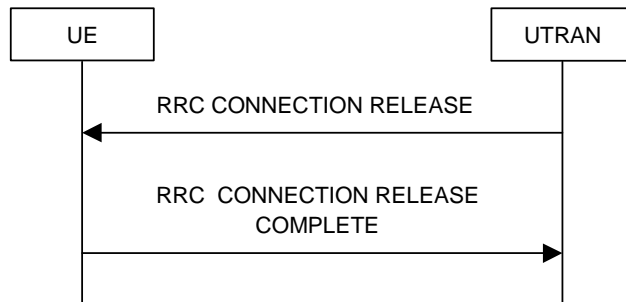

Figure 9: RRC Connection Release procedure on the DCCH



Figure 10: RRC Connection Release procedure on the CCCH

8.1.4.1 General

The purpose of this procedure is to release the RRC connection including the signalling link and all radio bearers between the UE and the UTRAN. By doing so, all established signalling flows and signalling connections will be released.

8.1.4.2 Initiation

When the UE is in state CELL_DCH or CELL_FACH, the UTRAN may at anytime initiate an RRC connection release by transmitting an RRC CONNECTION RELEASE message using UM RLC.

When UTRAN transmits an RRC CONNECTION RELEASE message ~~as in response to a received RRC CONNECTION RE-ESTABLISHMENT REQUEST (subclause 8.1.5), CELL UPDATE (subclause 8.3.1) or URA UPDATE (subclause 8.3.2) message from the UE, UTRAN should use the downlink CCCH to transmit the message. In all other cases the downlink DCCH should be used, although the downlink CCCH may be used as well.~~

UTRAN may transmit several RRC CONNECTION RELEASE messages to increase the probability of proper reception of the message by the UE. The number of repeated messages and the interval between the messages is a network option.

8.1.4.3 Reception of an RRC CONNECTION RELEASE message by the UE

The UE shall receive and act on an RRC CONNECTION RELEASE message in states CELL_DCH and CELL_FACH. Furthermore this procedure can interrupt any ongoing procedures with the UE in the above listed states.

When the UE receives the first RRC CONNECTION RELEASE message, it shall:

- in state CELL_DCH:
 - ~~initialise the counter V308 with the value of the IE "Number of RRC Message Transmissions", to zero which indicates the number of times the RRC CONNECTION RELEASE COMPLETE message shall be sent;~~
 - ~~set the IE "RRC transaction identifier" in the RRC CONNECTION RELEASE COMPLETE message to~~
 - the value of "RRC transaction identifier" in the entry for the RRC CONNECTION RELEASE message in the table "Accepted transactions" in the variable TRANSACTIONS, and;
 - ~~clear that entry.~~
 - ~~transmit-submit an RRC CONNECTION RELEASE COMPLETE message to the lower layers for transmission using UM RLC on the DCCH to the UTRAN;~~
 - ~~start timer T308 when the RRC CONNECTION RELEASE COMPLETE message is sent on the radio interface.~~
- in state CELL_FACH and
 - ~~if the RRC CONNECTION RELEASE message was received on the DCCH~~
 - ~~set the IE "RRC transaction identifier" in the RRC CONNECTION RELEASE COMPLETE message to~~
 - the value of "RRC transaction identifier" in the entry for the RRC CONNECTION RELEASE message in the table "Accepted transactions" in the variable TRANSACTIONS, and;
 - ~~clear that entry.~~
 - ~~transmit-submit an RRC CONNECTION RELEASE COMPLETE message to the lower layers for transmission using AM RLC on the DCCH to the UTRAN.~~
 - ~~when the successful transmission of the RRC CONNECTION RELEASE message has been confirmed by the lower layers:~~
 - ~~release all its radio resources, and~~

- indicate the release of all signalling connections and established radio access bearers in the variable ESTABLISHED_RABS to the non-access stratum, and
- pass the value of the IE "Release cause" received in the RRC CONNECTION RELEASE message to the non-access stratum;
- and the procedure ends.

When in state CELL_FACH and

- if the RRC CONNECTION RELEASE message was received on the CCCH,
 - release all its radio resources, and indicate the release of all signalling connections and established radio access bearers in the variable ESTABLISHED_RABS to the non-access stratum and pass the value of the IE "Release cause" received in the RRC CONNECTION RELEASE message to the non-access stratum
 - enter idle mode
 - perform the actions specified in subclause 8.5.2 when entering idle mode,
 - and the procedure ends.

~~the UE shall not transmit an RRC CONNECTION RELEASE COMPLETE message.~~

~~Any succeeding RRC CONNECTION RELEASE messages that are received by the UE shall be ignored.~~

~~The UE shall indicate release of all current signalling flows connections and established radio access bearers in the variable ESTABLISHED_RABS to the non-access stratum and pass the value of the IE "Release cause" received in the RRC CONNECTION RELEASE message to the non-access stratum.~~

~~From the time of the indication of release to the non-access stratum until the UE has entered idle mode, any non-access stratum request to establish a new RRC signalling connection shall be queued. This new request may be processed only after the UE has entered idle mode.~~

~~When in state CELL_FACH and if the RRC CONNECTION RELEASE message was received on the CCCH, the UE shall release all its radio resources, enter idle mode and the procedure ends on the UE side. Actions the UE shall perform when entering idle mode are given in subclause 8.5.2.~~

8.1.4.4 Invalid RRC CONNECTION RELEASE message

If the RRC CONNECTION RELEASE message contains a protocol error causing the variable PROTOCOL_ERROR_REJECT to be set to TRUE according to clause 16, and if the "protocol error cause" in PROTOCOL_ERROR_INFORMATION is set to any cause value except "ASN.1 violation or encoding error", the UE shall perform procedure specific error handling as follows:

The UE shall:

- ignore any IE(s) causing the error but treat the rest of the RRC CONNECTION RELEASE message as normal according to subclause 8.1.4.3, with an addition of the following actions;
- **if the RRC CONNECTION RELEASE message was received on the DCCH:**
 - set the IE "RRC transaction identifier" in the RRC CONNECTION RELEASE COMPLETE message to
 - the value of "RRC transaction identifier" in the entry for the RRC CONNECTION RELEASE message in the table "Rejected transactions" in the variable TRANSACTIONS, and;
 - clear that entry.
 - **include the IE "Error indication" in the RRC CONNECTION RELEASE COMPLETE message with:**
 - **the IE "Failure cause" set to the cause value "Protocol error" and**
 - **the IE "Protocol error information" set to the value of the variable PROTOCOL_ERROR_INFORMATION;**

8.1.4.4a Cell re-selection or radio link failure

~~If the UE performs cell re-selection or the radio link failure criteria according to subclause 8.5.6 is met at any time during the RRC connection release procedure and the UE has not yet entered idle mode, the UE shall perform a cell update procedure according to subclause 8.3.1.~~

8.1.4.5 Expiry of timer T308, unacknowledged mode transmission

When in state CELL_DCH and the timer T308 expires, the UE shall:

- ~~decrease increment V308 by one;~~
- if V308 is equal to or smaller than N308:
 - retransmit the RRC CONNECTION RELEASE COMPLETE message;
- if V308 is greater than N308:
 - release all its radio resources;
 - ~~enter idle mode;~~ and the procedure ends on the UE side. Actions the UE shall perform when entering idle mode are given in subclause 8.5.2.
 - ~~perform the actions specified in subclause 8.5.2 when entering idle mode;~~
 - ~~and the procedure ends.~~

8.1.4.6 Successful transmission of the RRC CONNECTION RELEASE COMPLETE message, acknowledged mode transmission

When acknowledged mode was used and RLC has confirmed the transmission of the RRC CONNECTION RELEASE COMPLETE message the UE shall:

- release all its radio resources;
- ~~enter idle mode;~~ and the procedure ends on the UE side. Actions the UE shall perform when entering idle mode are given in subclause 8.5.2.
- ~~perform the actions specified in subclause 8.5.2 when entering idle mode;~~
- ~~and the procedure ends.~~

8.1.4.7 Reception of an RRC CONNECTION RELEASE COMPLETE message by UTRAN

When UTRAN receives an RRC CONNECTION RELEASE COMPLETE message from the UE, it should:

- release all UE dedicated resources and the procedure ends on the UTRAN side.

8.1.4.8 Unsuccessful transmission of the RRC CONNECTION RELEASE COMPLETE message, acknowledged mode transmission

When acknowledged mode was used and RLC does not succeed in transmitting the RRC CONNECTION RELEASE COMPLETE message, the UE shall:

- release all its radio resources;
- ~~enter idle mode;~~ and the procedure ends on the UE side.
- ~~perform the actions specified in subclause 8.5.2 when entering idle mode;~~
- ~~and the procedure ends.~~

~~Actions the UE shall perform when entering idle mode are given in subclause 8.5.2.~~

8.1.4.9 Detection of loss of dedicated physical channel by UTRAN in CELL_DCH state

If the release is performed from the state CELL_DCH, and UTRAN detects loss of the dedicated physical channel according to subclause 8.5.6, UTRAN may release all UE dedicated resources, even if no RRC CONNECTION RELEASE COMPLETE message has been received.

8.1.4.10 ~~No reception of~~ Failure to receive an RRC CONNECTION RELEASE COMPLETE message by UTRAN

If UTRAN does not receive any RRC CONNECTION RELEASE COMPLETE message, it should release all UE dedicated resources.

8.1.5 RRC connection re-establishment

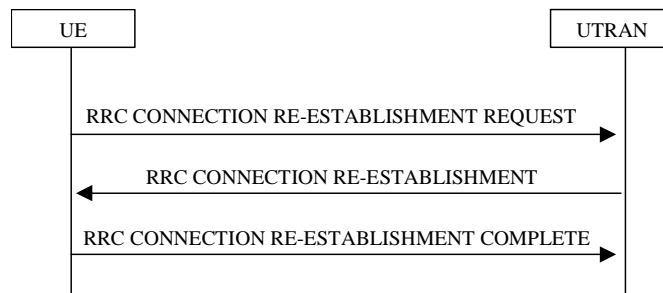

Figure 11: RRC Connection Re-establishment, successful case

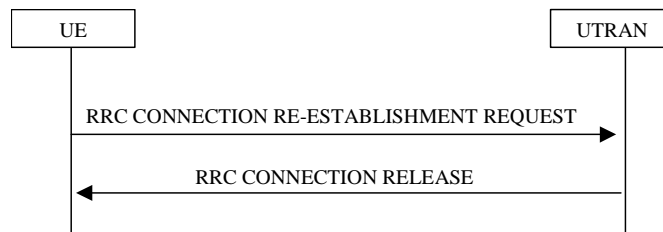

Figure 12: RRC Connection Re-establishment, failure case

8.1.5.1 General

The purpose of this procedure is to act on a lost RRC connection.

8.1.5.2 Initiation

When a UE loses the radio connection in CELL_DCH due to e.g. radio link failure (see subclause 8.5.6), detection of RLC unrecoverable error (amount of the retransmission of RESET PDU reaches the value of Max DAT and receives no ACK), the UE may initiate a new cell selection by transiting to CELL_FACH state.

If timer T314=0 and timer T315=0 the UE shall:

- Enter idle mode. The procedure ends and a connection failure may be indicated to the non-access stratum. Other actions the UE shall
- perform other actions when entering idle mode from connected mode are as specified in subclause 8.5.2.
- The procedure ends and a connection failure may be indicated to the non-access stratum.

If timer T314=0 the UE shall:

- Release locally all radio bearers, except Signalling Radio Bearers, which are associated with T314. An indication may be sent to the non-access stratum.

If timer T315=0 the UE shall:

- Release locally all radio bearers which are associated with T315. An indication may be sent to the non-access stratum.

If T314>0, the UE shall re-start timer T314.

If T315>0, the UE shall re-start timer T315.

Upon initiation of the procedure, the UE shall set the variable `PROTOCOL_ERROR_INDICATOR` to FALSE.

The IE "AM_RLC error indication (for c-plane)" shall be set when the UE detects unrecoverable error (amount of the retransmission of RESET PDU reaches the value of Max DAT and receives no ACK) in an AM RLC entity for the signalling link. The IE "AM_RLC error indication (for u-plane)" shall be set when the UE detects unrecoverable error in an AM RLC entity (for u-plane) for u-plane link.

UE shall include the START values from each CN domain in RRC CONNECTION RE-ESTABLISHMENT REQUEST message.

UE shall set CFN in relation to SFN of current cell according to 8.5.17.

8.1.5.3 Detection of "in service area"

If the UE detects "in service area"(see subclause 8.5.9), it shall:

- set the IE "U-RNTI" to the value stored in the UE;
- if the value of the variable `PROTOCOL_ERROR_INDICATOR` is TRUE:
 - set the IE "Protocol error indicator" to TRUE;
 - set the IE "Protocol error information" set to the value of the variable `PROTOCOL_ERROR_INFORMATION`;
- if the value of the variable `PROTOCOL_ERROR_INDICATOR` is FALSE;
 - set the IE "Protocol error indicator" to FALSE;
- include an IE "Measured Results on RACH", as specified in the IE "Intra-frequency reporting quantity for RACH reporting" and the IE "Maximum number of reported cells on RACH" in system information block type 12;
- transmit an RRC CONNECTION RE-ESTABLISHMENT REQUEST message on the uplink CCCH and start timer T301.

8.1.5.4 Reception of an RRC CONNECTION RE-ESTABLISHMENT REQUEST message by the UTRAN

UTRAN may either:

- initiate the RRC connection re-establishment procedure and transmit an RRC CONNECTION RE-ESTABLISHMENT message on the downlink DCCH on FACH or CCCH; or
- initiate the RRC connection release procedure (see subclause 8.1.4) by transmitting an RRC CONNECTION RELEASE message on the downlink CCCH on FACH.

When the UTRAN detects AM_RLC unrecoverable error (amount of the retransmission of RESET PDU reaches the value of Max DAT and receives no ACK), it waits for RRC CONNECTION RE-ESTABLISHMENT REQUEST message from the UE and when the UTRAN receives it, UTRAN commands the UE to reset all AM_RLC entities by sending RRC CONNECTION RE-ESTABLISHMENT message.

8.1.5.5 Reception of an RRC CONNECTION RE-ESTABLISHMENT message by the UE

Upon reception of the RRC CONNECTION RE-ESTABLISHMENT message the UE shall stop timer T301, and use the contents of the RRC CONNECTION RE-ESTABLISHMENT message as specified in subclause 8.6, unless specified otherwise in the following:

- For each reconfigured radio bearer use the mapping option applicable for the transport channels used according to the IE "RB mapping info";
- Configure MAC multiplexing if that is needed in order to use appropriate transport channel(s);
- Use MAC logical channel priority when selecting TFC in MAC.

If neither the IEs "PRACH info" nor "Uplink DPCH info" is included, the UE shall:

- let the physical channel of type PRACH that is given in system information Block Type 6 be the default in uplink;
- if system information block type 6 is not present in the cell:
 - let the physical channel of type PRACH given in system information block type 5 be the default in uplink.

If neither the IEs "Secondary CCPCH info" nor "Downlink DPCH info" is included, the UE shall:

- start to receive the physical channel of type Secondary CCPCH that is given in system information.

The UE shall use the transport channel(s) applicable for the physical channel types that is used. If the IE "TFS" is neither included nor previously stored in the UE for that transport channel(s), the UE shall:

- use the TFS given in system information.

If none of the TFS stored is compatible with the physical channel, the UE shall:

- delete the stored TFS;
- use the TFS given in system information.

If the IE "New C-RNTI" is included, the UE shall:

- use that C-RNTI when using common transport channels of type RACH, FACH and CPCH in the current cell.

If the IE "New U-RNTI" is included, the UE shall:

- update its identity.

If the IEs "CN domain identity" and "NAS system information" are included, the UE shall:

- forward the content of the IE to the non-access stratum entity of the UE indicated by the IE "CN domain identity".

The UE shall enter a state according to 8.5.7.

After successful state transition, the UE shall:

- check if the variable RB_UPLINK_CIPHERING_ACTIVATION_TIME_INFO is set;
- if the variable is set:
 - include and set the IE "Radio bearer uplink ciphering activation time info" to the value of that variable;
- transmit an RRC CONNECTION RE-ESTABLISHMENT COMPLETE message on the uplink DCCH using AM RLC.

When the successful delivery of the RRC CONNECTION RE-ESTABLISHMENT COMPLETE message has been confirmed by RLC, the UE shall clear the variable RB_UPLINK_CIPHERING_ACTIVATION_TIME_INFO and the procedure ends.

8.1.5.6 T314 timeout

Upon expiry of timer T314 the UE shall:

- if timer T301 is running:
 - continue awaiting response message from UTRAN;
- if timer T301 is not running and timer T315 is running:
 - release locally all radio bearers (except Signalling Radio Bearers) which are associated with T314. An indication may be sent to the non-access stratum;
- if timers T301 and T315 are not running:
 - enter idle mode.
 - perform actions specified in subclause 8.5.2 when entering idle mode from connected mode as.
 - The procedure ends and a connection failure may be indicated to the non-access stratum. The procedure ends and a connection failure may be indicated to the non-access stratum. Other actions the UE shall perform when entering idle mode from connected mode are specified in subclause 8.5.2.

8.1.5.7 T315 timeout

Upon expiry of timer T315 the UE shall:

- if timer T301 is running:
 - continue awaiting response message from UTRAN;
- if timer T301 is not running and timer T314 is running:
 - release locally all radio bearers (except Signalling Radio Bearers) which are associated with T315. An indication may be sent to the non-access stratum;
- if timers T301 and T314 are not running:
 - enter idle mode.
 - perform actions specified in subclause 8.5.2 when entering idle mode from connected mode as.
 - The procedure ends and a connection failure may be indicated to the non-access stratum. Other actions the UE shall perform when entering idle mode from connected mode are specified in subclause 8.5.2.

8.1.5.8 Invalid RRC CONNECTION RE-ESTABLISHMENT message

If the UE receives an RRC CONNECTION RE-ESTABLISHMENT message, which contains a protocol error causing the variable `PROTOCOL_ERROR_REJECT` to be set to `TRUE` according to clause 16, the UE shall perform procedure specific error handling as follows:

The UE shall check the value of `V301`, and

- if `V301` is equal to or smaller than `N301`:
 - set the variable `PROTOCOL_ERROR_INDICATOR` to `TRUE`;
 - transmit a new RRC CONNECTION RE-ESTABLISHMENT REQUEST message on the uplink CCCH;
 - restart timer T301;
 - increase counter `V301`;

- set the IEs in the RRC CONNECTION RE-ESTABLISHMENT REQUEST message according to subclause 8.1.5.2.;
- if V301 is greater than N301:
 - enter idle mode.
 - perform actions specified in subclause 8.5.2 when entering idle mode from connected mode as.
 - The procedure ends and a connection failure may be indicated to the non-access stratum. The procedure ends and a connection failure may be indicated to the non-access stratum. Other actions the UE shall perform when entering idle mode from connected mode are specified in subclause 8.5.2.

8.1.5.9 T301 timeout or DPCH failure

Upon expiry of timer T301, or if the UE failed to re-establish the RRC Connection indicated in the RRC CONNECTION RE-ESTABLISHMENT message the UE shall:

- if timers T314 and T315 are not running:
 - enter idle mode.
 - perform actions specified in subclause 8.5.2 when entering idle mode from connected mode as.
 - The procedure ends and a connection failure may be indicated to the non-access stratum. The procedure ends and a connection failure may be indicated to the non-access stratum. Other actions the UE shall perform when entering idle mode from connected mode are specified in subclause 8.5.2;
- if timer T314 has expired during the last T301 cycle and T315 is still running:
 - release locally all radio bearers (except Signalling Radio Bearers) which are associated with T314. An indication may be sent to the non-access stratum;
- if timer T315 has expired during the last T301 cycle and T314 is still running,
 - release locally all radio bearers (except Signalling Radio Bearers) which are associated with T315. An indication may be sent to the non-access stratum;

The UE shall re-check whether it is still in "in service area" (see 8.5.9).

If the UE detects "in service area", it shall perform procedure specific error handling as follows:

- check the value of V301;
- if V301 is equal to or smaller than N301:
 - set the IEs in the RRC CONNECTION RE-ESTABLISHMENT REQUEST message according to subclause 8.1.5.3;
 - transmit a new RRC CONNECTION RE-ESTABLISHMENT REQUEST message on the uplink CCCH and restart timer T301;
- if V301 is greater than N301:
 - enter idle mode. The procedure ends and a connection failure may be indicated to the non-access stratum. Other actions the UE shall perform when entering idle mode from connected mode are specified in subclause 8.5.2;

If the UE does not detect "in service area", it shall:

- continue searching for "in service area".

8.1.5.10 Reception of an RRC CONNECTION RE-ESTABLISHMENT COMPLETE message by the UTRAN

When UTRAN has received the RRC CONNECTION RE-ESTABLISHMENT COMPLETE message, the procedure ends on the UTRAN side.

8.1.6 Transmission of UE capability information

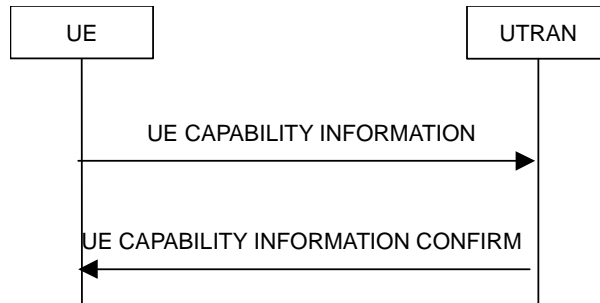

Figure 13: Transmission of UE capability information, normal flow

8.1.6.1 General

The UE capability update procedure is used by the UE to convey UE specific capability information to the UTRAN.

8.1.6.2 Initiation

The UE shall initiate the UE capability update procedure in the following situations:

- ~~After the UE has received~~receives a UE CAPABILITY ENQUIRY message from the UTRAN;
- ~~If while in RRC connected state the UE capabilities change compared to those stored in the variable UE_CAPABILITY_TRANSFERRED change during the RRC connection.~~

~~The UE transmits the UE CAPABILITY INFORMATION message on the uplink DCCH using UM RLC, starts timer T304 and resets counter V304.~~

If the UE CAPABILITY INFORMATION message is sent in response to a UE CAPABILITY ENQUIRY message, the UE shall:

- ~~include the IE "RRC transaction identifier", and;~~
- ~~set it to the value of "RRC transaction identifier" in the entry for the UE CAPABILITY ENQUIRY message in the table "Accepted transactions" in the variable TRANSACTIONS, and;~~
- ~~clear that entry.~~
- include the UTRAN-specific UE capability information elements into the IE "UE radio capability", according to the requirement given in the IE "Capability update requirement" in the UE CAPABILITY ENQUIRY message;
- include one or more inter-system classmarks into the IE "UE system specific capability", according to the requirement given in the IE "Capability update requirement" in the UE CAPABILITY ENQUIRY message.

~~If the UE CAPABILITY INFORMATION message is sent because one or more of the UE capabilities change compared to those stored in the variable UE_CAPABILITY_TRANSFERRED has changed while in RRC connected state, the UE shall include the information elements associated with the capabilities that have changed in the UE CAPABILITY INFORMATION message.~~

~~If the UE is in CELL_PCH or URA_PCH state, it shall first perform a cell update procedure using the cause "uplink data transmission", see subclause 8.3.1.~~

The UE RRC shall submit the UE CAPABILITY INFORMATION message to the lower layers for transmission on the uplink DCCH using AM RLC. When the message has been sent on the radio interface the UE RRC shall start timer T304 and reset counter V304.

8.1.6.3 Reception of an UE CAPABILITY INFORMATION message by the UTRAN

Upon reception of a UE CAPABILITY INFORMATION message, the UTRAN should transmit a UE CAPABILITY INFORMATION CONFIRM message on the downlink DCCH using UM or AM RLC. After the UE CAPABILITY INFORMATION CONFIRM message has been ~~sent~~submitted to the lower layers for transmission, the procedure is complete.

8.1.6.4 Reception of the UE CAPABILITY INFORMATION CONFIRM message by the UE

Upon reception of a UE CAPABILITY INFORMATION CONFIRM message, the UE shall:

- stop timer T304;
- update its variable UE_CAPABILITY_TRANSFERRED ~~which with the UE capabilities it has last transmitted to the UTRAN during the current RRC connection.~~

8.1.6.5 Invalid UE CAPABILITY INFORMATION CONFIRM message

If the UE receives a UE CAPABILITY INFORMATION CONFIRM message, which contains a protocol error causing the variable PROTOCOL_ERROR_REJECT to be set to TRUE according to clause 16, the UE shall perform procedure specific error handling as follows:

- stop timer T304;
- transmit an RRC STATUS message on the uplink DCCH using AM RLC ~~and include the IE "Protocol error information" with contents set to the value of the variable PROTOCOL_ERROR_INFORMATION;~~
- ~~include the IE "Identification of received message", and;~~
 - ~~set the IE "Received message type" to UE CAPABILITY INFORMATION CONFIRM;~~
 - ~~set the IE "RRC transaction identifier" to the value of "RRC transaction identifier" in the entry for the UE UE CAPABILITY INFORMATION CONFIRM message in the table "Rejected transactions" in the variable TRANSACTIONS, and;~~
 - ~~clear that entry;~~
- ~~include the IE "Protocol error information" with contents set to the value of the variable PROTOCOL_ERROR_INFORMATION;~~
- ~~when the successful delivery of the RRC STATUS message has been confirmed by RLC submitted to lower layers for transmission:~~
 - restart timer T304 and resume normal operation as if the invalid UE CAPABILITY INFORMATION CONFIRM message has not been received.

8.1.6.6 T304 timeout

Upon expiry of timer T304, the UE shall check the value of V304 and:

- if V304 is smaller than or equal to N304:
 - retransmit a UE CAPABILITY INFORMATION message with the IEs as set in the last unsuccessful attempt;
 - restart timer T304;
 - ~~increase increment~~ counter V304;

- if V304 is greater than N304:
- assume that radio link failure has occurred;
- initiate the RRC connection re-establishment procedure.

8.1.7 UE capability enquiry

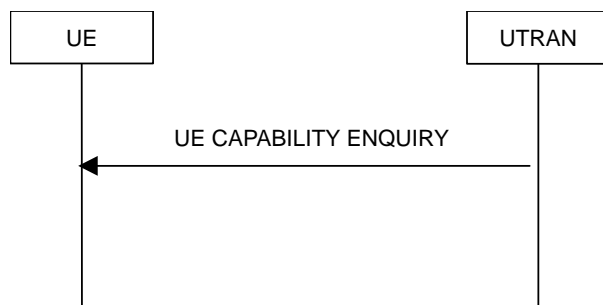

Figure 14: UE capability enquiry procedure, normal flow

8.1.7.1 General

The UE capability enquiry can be used to request the UE to transmit its capability information related to any radio access network that is supported by the UE.

8.1.7.2 Initiation

The UE capability enquiry procedure is initiated by UTRAN by transmitting a UE CAPABILITY ENQUIRY message on the DCCH using UM or AM RLC.

8.1.7.3 Reception of an UE CAPABILITY ENQUIRY message by the UE

Upon reception of an UE CAPABILITY ENQUIRY message, the UE shall initiate the transmission of UE capability information procedure, which is specified in subclause 8.1.6.

8.1.7.4 Invalid UE CAPABILITY ENQUIRY message

If the UE receives a UE CAPABILITY ENQUIRY message, which contains a protocol error causing the variable `PROTOCOL_ERROR_REJECT` to be set to `TRUE` according to clause 16, the UE shall perform procedure specific error handling as follows:

- transmit an RRC STATUS message on the uplink DCCH using AM RLC;
- include the IE "Identification of received message", and;
 - set the IE "Received message type" to UE CAPABILITY ENQUIRY;
 - set the IE "RRC transaction identifier" to the value of "RRC transaction identifier" in the entry for the UE CAPABILITY ENQUIRY message in the table "Rejected transactions" in the variable TRANSACTIONS, and;
 - clear that entry.
- include the IE "Protocol error information" with contents set to the value of the variable `PROTOCOL_ERROR_INFORMATION`;
- when the successful delivery of the RRC STATUS message has been confirmed by RLC submitted to lower layers for transmission:
 - resume normal operation as if the invalid UE CAPABILITY ENQUIRY message has not been received.

8.1.8 Initial Direct transfer

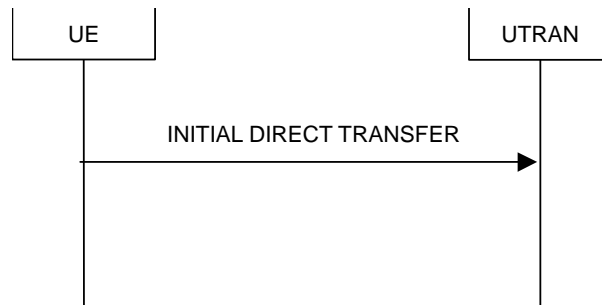

Figure 15: Initial Direct transfer in the uplink, normal flow

8.1.8.1 General

The initial direct transfer procedure is used in the uplink to establish signalling connections and signalling flows. It is also used to carry the initial higher layer (NAS) messages over the radio interface.

A signalling connection comprises one or several signalling flows. This procedure requests the establishment of a new flow, and triggers, depending on the routing and if no signalling connection exists for the chosen route for the flow, the establishment of a signalling connection.

8.1.8.2 Initiation of Initial direct transfer procedure in the UE

In the UE, the initial direct transfer procedure shall be initiated, when the upper layers request the initialization of a new flow. This request also includes a request for the transfer of a NAS message. When not stated otherwise elsewhere, the UE may also initiate the initial direct transfer procedure when another procedure is ongoing, and in that case the state of the latter procedure shall not be affected. The UE shall transmit the INITIAL DIRECT TRANSFER message on the uplink DCCH using AM RLC on RB 3.

A new signalling connection request may be received from the non-access stratum subsequent to the indication of the release of a previously established signalling connection to the non-access stratum. From the time of the indication of release to the non-access stratum until the UE has entered idle mode, any such non-access stratum request to establish a new signalling connection shall be queued. This request shall be processed after the UE has entered idle mode.

The System Information Block Type 1 and 13 may contain CN NAS information which the upper layers in the UE can use in choosing the value to set the IE "CN Domain Identity" to. If available the UE shall use this CN NAS information as well as user preference and subscription information in setting the value of IE "CN Domain Identity" to indicate which CN node the NAS message is destined to. If the upper layers in the UE have not set a value for the IE "CN Domain Identity" RRC shall set it to the value "don't care". In addition the UE shall set the IE "Service Descriptor" and the IE "Flow Identifier" to the value allocated by the UE for that particular flow.

In CELL_FACH state, the UE shall include IE "Measured results on RACH" into the INITIAL DIRECT TRANSFER message if RACH measurement reporting has been requested in the IE "Intra-frequency reporting quantity for RACH reporting" and the IE "Maximum number of reported cells on RACH" in "system information block type 12" (or "system information block type 11" if "system information block type 12" is not being broadcast).

When the successful delivery of the INITIAL DIRECT TRANSFER message has been confirmed by RLC the procedure ends.

8.1.8.3 Reception of INITIAL DIRECT TRANSFER message by the UTRAN

On reception of the INITIAL DIRECT TRANSFER message the NAS message should be routed using the IE "CN Domain Identity" and the IE "Service Descriptor". The UTRAN should use the UE context to store the contents of the IE "Flow Identifier" for that particular flow.

If no signalling connection exists towards the chosen node, then a signalling connection is established.

If the IE "Measured results on RACH" is present in the message, the UTRAN should extract the contents to be used for radio resource control.

When the UTRAN receives an INITIAL DIRECT TRANSFER message, it shall not affect the state of any other ongoing RRC procedures, when not stated otherwise elsewhere.

8.1.9 Downlink Direct transfer



Figure 16: Downlink Direct transfer, normal flow

8.1.9.1 General

The downlink direct transfer procedure is used in the downlink direction to carry higher layer (NAS) messages over the radio interface.

8.1.9.2 Initiation of downlink direct transfer procedure in the UTRAN

In the UTRAN, the direct transfer procedure is initiated when the upper layers request the transfer of a NAS message after the initial signalling connection is established. The UTRAN may also initiate the downlink direct transfer procedure when another RRC procedure is ongoing, and in that case the state of the latter procedure shall not be affected. The UTRAN shall transmit the DOWNLINK DIRECT TRANSFER message on the downlink DCCH using AM RLC on RB 3 or RB 4. The UTRAN should select the RB according to the following:

- If the non-access stratum indicates "low priority" for this message, RB 4 should be selected, if available. Specifically, for a GSM-MAP based CN, RB 4 should, if available, be selected when "SAPI 3" is requested. RB 3 should be selected when RB 4 is not available.
- If the non-access stratum indicates "high priority" for this message, RB 3 should be selected. Specifically, for a GSM-MAP based CN, RB 3 should be selected when "SAPI 0" is requested.

The UTRAN sets the IE "CN Domain Identity" to indicate, which CN domain the NAS message is originated from.

8.1.9.3 Reception of a DOWNLINK DIRECT TRANSFER message by the UE

Upon reception of the DOWNLINK DIRECT TRANSFER message, the UE RRC shall, using the IE "CN Domain Identity", route the contents of the higher layer PDU and the value of the IE "CN Domain Identity" to the correct higher layer entity.

The UE shall clear the entry for the DOWNLINK DIRECT TRANSFER message in the table "Accepted transactions" in the variable TRANSACTIONS.

When the UE receives a DOWNLINK DIRECT TRANSFER message, it shall not affect the state of any other ongoing RRC procedures when not stated otherwise elsewhere.

8.1.9.4 Invalid DOWNLINK DIRECT TRANSFER message

If the UE receives a DOWNLINK DIRECT TRANSFER message, which contains a protocol error causing the variable `PROTOCOL_ERROR_REJECT` to be set to `TRUE` according to clause 16, the UE shall perform procedure specific error handling as follows:

- transmit an RRC STATUS message on the uplink DCCH using AM RLC;
- include the IE "Identification of received message", and;
 - set the IE "Received message type" to DOWNLINK DIRECT TRANSFER;
 - set the IE "RRC transaction identifier" to the value of "RRC transaction identifier" in the entry for the DOWNLINK DIRECT TRANSFER message in the table "Rejected transactions" in the variable TRANSACTIONS, and;
 - clear that entry.
- include the IE "Protocol error information" with contents set to the value of the variable PROTOCOL_ERROR_INFORMATION.

When ~~the successful delivery of the RRC STATUS message has been confirmed by RLC~~submitted to lower layers for transmission, the UE shall resume normal operation as if the invalid DOWNLINK DIRECT TRANSFER message has not been received.

8.1.10 Uplink Direct transfer

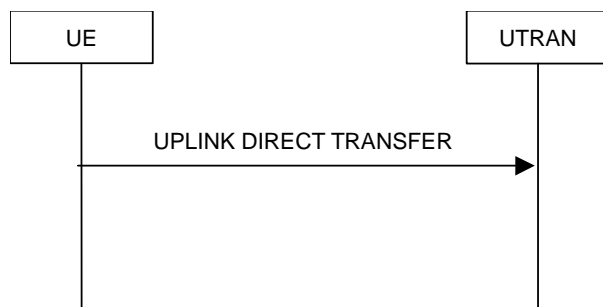

Figure 17: Uplink Direct transfer, normal flow

8.1.10.1 General

The uplink direct transfer procedure is used in the uplink direction to carry all subsequent higher layer (NAS) messages over the radio interface belonging to a signalling flow.

8.1.10.2 Initiation of uplink direct transfer procedure in the UE

In the UE, the uplink direct transfer procedure shall be initiated when the upper layers request a transfer of a NAS message after the initial signalling connection is established and upper layer indication is provided indicating that the NAS message belongs to an on-going signalling flow. When not stated otherwise elsewhere, the UE may initiate the uplink direct transfer procedure when another procedure is ongoing, and in that case the state of the latter procedure shall not be affected. The UE shall transmit the UPLINK DIRECT TRANSFER message on the uplink DCCH using AM RLC on RB 3 or RB 4. The UE shall select the RB according to the following:

- if the non-access stratum indicates "low priority" for this message, RB 4 shall be selected, if available. Specifically, for a GSM-MAP based CN, RB 4 shall, if available, be selected when "SAPI 3" is requested. RB 3 shall be selected when RB 4 is not available.
- if the non-access stratum indicates "high priority" for this message, RB 3 shall be selected. Specifically, for a GSM-MAP based CN, RB 3 shall be selected when "SAPI 0" is requested.

The UE shall set the IE "Flow Identifier" to the same value as that allocated to that particular flow when transmitting the INITIAL DIRECT TRANSFER message for that flow.

8.1.10.3 Reception of UPLINK DIRECT TRANSFER message by the UTRAN

On reception of the UPLINK DIRECT TRANSFER message the NAS message should be routed using the value indicated in the IE "Flow Identifier".

If the IE "Measured results on RACH" is present in the message, the UTRAN should extract the contents to be used for radio resource control.

When the UTRAN receives an UPLINK DIRECT TRANSFER message, it shall not affect the state of any other ongoing RRC procedures, when not stated otherwise elsewhere.

8.1.11 UE dedicated paging

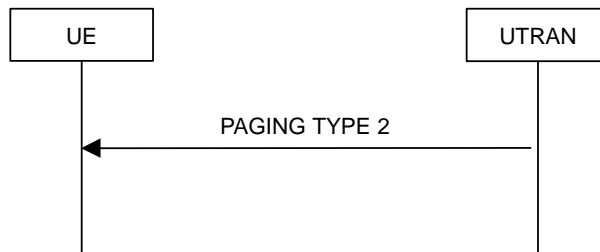

Figure 18: UE dedicated paging

8.1.11.1 General

This procedure is used to transmit dedicated paging information to one UE in connected mode in states CELL_DCH and CELL_FACH. Upper layers in the network may request initiation of paging.

8.1.11.2 Initiation

For an UE in states CELL_DCH or CELL_FACH, UTRAN initiates the procedure by transmitting a PAGING TYPE 2 message on the DCCH using AM RLC. When not stated otherwise elsewhere, the UTRAN may initiate the UE dedicated paging procedure also when another RRC procedure is ongoing, and in that case the state of the latter procedure shall not be affected.

8.1.11.3 Reception of an PAGING TYPE 2 message by the UE

When the UE receives a PAGING TYPE 2 message, it shall not affect the state of any other ongoing RRC procedures, when not stated otherwise elsewhere.

The UE shall indicate that a Paging message has been received and forward the paging cause and the paging record type identifier to the upper layer entity indicated by the CN domain identity.

The UE shall clear the entry for the PAGING TYPE 2 message in the table "Accepted transactions" in the variable TRANSACTIONS.

8.1.11.4 Invalid PAGING TYPE 2 message

If the UE receives a PAGING TYPE 2 message, which contains a protocol error causing the variable PROTOCOL_ERROR_REJECT to be set to TRUE according to clause 16, the UE shall perform procedure specific error handling as follows:

- transmit an RRC STATUS message on the uplink DCCH using AM RLC;
- include the IE "Identification of received message", and;
 - set the IE "Received message type" to PAGING TYPE 2;
 - set the IE "RRC transaction identifier" to the value of "RRC transaction identifier" in the entry for the PAGING TYPE 2 message in the table "Rejected transactions" in the variable TRANSACTIONS, and;
 - clear that entry.
- include the IE "Protocol error information" with contents set to the value of the variable PROTOCOL_ERROR_INFORMATION.
- when the successful delivery of the RRC STATUS message has been confirmed by RLC submitted to lower layers for transmission, the UE shall resume normal operation as if the invalid PAGING TYPE 2 message has not been received.

8.1.12 Security mode control

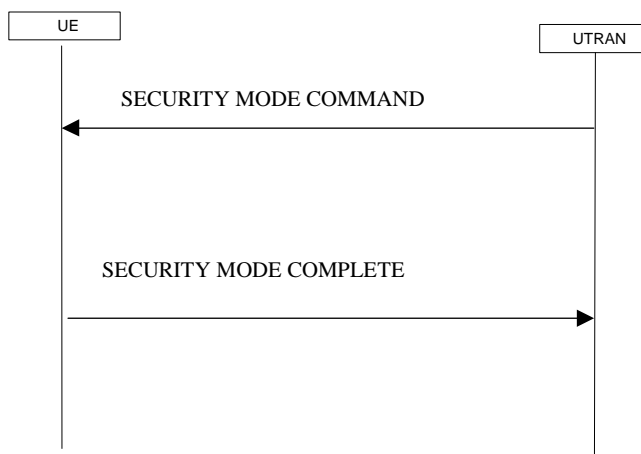

Figure 19: Security mode control procedure

8.1.12.1 General

The purpose of this procedure is to trigger the stop or start of ciphering or to command the restart of the ciphering with the new ciphering configuration, both for the signalling link and for any of the radio bearers.

It is also used to start integrity protection or to modify the integrity protection configuration for uplink and downlink signalling.

8.1.12.2 Initiation

8.1.12.2.1 Ciphering configuration change

To stop or start/restart ciphering, UTRAN sends a SECURITY MODE COMMAND message on the downlink DCCH in AM RLC using the old ciphering configuration. If no old ciphering configuration exists then the SECURITY MODE COMMAND is not ciphered.

Prior to sending the SECURITY MODE COMMAND, and for the CN domain as indicated in the IE "CN domain identity" in the SECURITY MODE COMMAND, UTRAN should:

- suspend all radio bearers using RLC-AM and RLC-UM;
- suspend all signalling radio bearers using RLC-AM and RLC-UM, except the signalling radio bearer used to send the SECURITY MODE COMMAND message on the downlink DCCH in RLC-AM;
- set, for the signalling radio bearer used to send the SECURITY MODE COMMAND, the "RLC send sequence number" in IE "Radio bearer downlink ciphering activation time info" in the IE "Ciphering mode info", at which time the new ciphering configuration shall be applied;
- set, for each suspended radio bearer and signalling radio bearer, the "RLC send sequence number" in IE "Radio bearer downlink ciphering activation time info" in the IE "Ciphering mode info", at which time the new ciphering configuration shall be applied.

While suspended, radio bearers and signalling radio bearers shall not deliver RLC PDUs with sequence number greater than or equal to the number in IE "Radio bearer downlink ciphering activation time info".

When the successful delivery of the SECURITY MODE COMMAND has been confirmed by RLC, UTRAN shall:

- resume all the suspended radio bearers and signalling radio bearers. The old ciphering configuration shall be applied for the transmission of RLC PDUs with RLC sequence number less than the number indicated in the IE "Radio bearer downlink ciphering activation time info", as sent to the UE. The new ciphering configuration shall

be applied for the transmission of RLC PDUs with RLC sequence number greater than or equal to the number indicated in IE "Radio bearer downlink ciphering activation time info", sent to the UE.

8.1.12.2 Integrity protection configuration change

To start or modify integrity protection, UTRAN sends a SECURITY MODE COMMAND message on the downlink DCCH in AM RLC using the new integrity protection configuration.

8.1.12.3 Reception of SECURITY MODE COMMAND message by the UE

Upon reception of the SECURITY MODE COMMAND message, the UE shall perform the actions for the received information elements according to 8.6.

If the IE "Security capability" is the same as indicated by variable UE_CAPABILITY_TRANSFERRED, the UE shall:

- suspend all radio bearers and signalling radio bearers (except the signalling radio bearer used to receive the SECURITY MODE COMMAND message on the downlink DCCH in RLC-AM) using RLC-AM or RLC-UM that belong to the CN domain indicated in the IE "CN domain identity", with RLC sequence number greater than or equal to the number in IE "Radio bearer downlink ciphering activation time info" in the IE "Ciphering mode info";
- set the IE "RRC transaction identifier" in the SECURITY MODE COMPLETE message to
 - the value of "RRC transaction identifier" in the entry for the SECURITY MODE CONTROL message in the table "Accepted transactions" in the variable TRANSACTIONS, and;
 - clear that entry;
- if the variable RB_UPLINK_CIPHERING_ACTIVATION_TIME_INFO is set:
 - include and set the IE "Radio bearer uplink ciphering activation time info" to the value of that variable, for the respective radio bearer and signalling radio bearer;
- when the radio bearers and signalling radio bearers have been suspended:
 - send a SECURITY MODE COMPLETE message on the uplink DCCH in AM RLC, using the old ciphering and the new integrity protection configuration;
- when the successful delivery of the SECURITY MODE COMPLETE message has been confirmed by RLC:
 - resume data transmission on any suspended radio bearer and signalling radio bearer mapped on RLC-AM or RLC-UM;
 - clear the variable RB_UPLINK_CIPHERING_ACTIVATION_TIME_INFO and the procedure ends. If a RLC reset occurs after the SECURITY MODE COMPLETE message has been confirmed by RLC, but before the activation time for when the new ciphering configuration shall be applied has elapsed, RRC in the UE configures RLC in the UE with the activation times as indicated in the SECURITY MODE COMPLETE, after the RLC reset.

For radio bearers and signalling radio bearers used by the CN indicated in the IE "CN domain identity", the UE shall:

- if a new integrity protection key has been received:
 - in the downlink:
 - use the new key;
 - set the HFN component of the downlink COUNT-I to zero at the RRC sequence number indicated in IE "Downlink integrity protection activation info" included in the IE "Integrity protection mode info";
 - in the uplink:
 - use the new key;
 - set the HFN component of the uplink COUNT-I to zero at the RRC sequence number indicated in IE "Uplink integrity protection activation info" included in the IE "Integrity protection mode info";

- if a new ciphering key is available:
 - in the downlink:
 - use the new key;
 - set the HFN component of the downlink COUNT-C to zero at the RLC sequence number indicated in IE "Radio bearer downlink ciphering activation time info" in the IE "Ciphering mode info";
 - in the uplink:
 - use the new key;
 - set the HFN component of the uplink COUNT-C to zero at the RLC sequence number indicated in IE "Radio bearer uplink ciphering activation time info".

If the IE "Security capability" is not the same as indicated by the variable UE_CAPABILITY_TRANSFERRED, the UE shall release all its radio resources, enter idle mode and the procedure ends on the UE side. Actions the UE shall perform when entering idle mode are given in subclause 8.5.2.

8.1.12.4 Cipher activation time too short

If the time specified by the IE "Activation time for DPCH" or the IE "Radio bearer downlink ciphering activation time info" contained in the IE "Ciphering mode info" has elapsed, the UE shall switch immediately to the new ciphering configuration.

8.1.12.5 Reception of SECURITY MODE COMPLETE message by the UTRAN

UTRAN should apply integrity protection on the received SECURITY MODE COMPLETE message and all subsequent messages with the new integrity protection configuration, if changed. When UTRAN has received a SECURITY MODE COMPLETE message and the integrity protection has successfully been applied, UTRAN shall ~~use~~

- for radio bearers using RLC-AM or RLC-UM:
 - ~~use~~ the old ciphering configuration for received RLC PDUs with RLC sequence number less than the RLC sequence number indicated in the IE "Radio bearer uplink ciphering activation time info" sent by the UE;
 - ~~use~~ the new ciphering configuration for received RLC PDUs with RLC sequence number greater than or equal to the RLC sequence number indicated in the IE "Radio bearer uplink ciphering activation time info" sent by the UE;
 - if an RLC reset occurs after the SECURITY MODE COMPLETE message has been received by UTRAN, but before the activation time for new ciphering key has been reached, ~~RRC in UTRAN~~ configures RLC in UTRAN with the new ciphering key and activation time after the RLC reset;
- for radio bearers using RLC-TM:
 - ~~use~~ the new ciphering configuration for the received RLC PDUs at the CFN as indicated in the IE "Activation time for DPCH" in the IE "Ciphering mode info";
- and the procedure ends.

8.1.12.6 Invalid SECURITY MODE COMMAND message

If the SECURITY MODE COMMAND message contains a protocol error causing the variable PROTOCOL_ERROR_REJECT to be set to TRUE according to clause 16, the UE shall perform procedure specific error handling as follows:

- transmit a SECURITY MODE FAILURE message on the uplink DCCH using AM RLC;
- ~~set the IE "RRC transaction identifier" in the SECURITY MODE FAILURE message to~~
- ~~the value of "RRC transaction identifier" in the entry for the SECURITY MODE CONTROL message in the table "Rejected transactions" in the variable TRANSACTIONS, and;~~

- clear that entry;
- set the IE "failure cause" to the cause value "protocol error";
- include the IE "Protocol error information" with contents set to the value of the variable `PROTOCOL_ERROR_INFORMATION`.
- when the successful delivery of the SECURITY MODE FAILURE message has been confirmed by RLC:
 - resume normal operation as if the invalid SECURITY MODE COMMAND message has not been received and the procedure ends.

8.1.13 Signalling flow release procedure

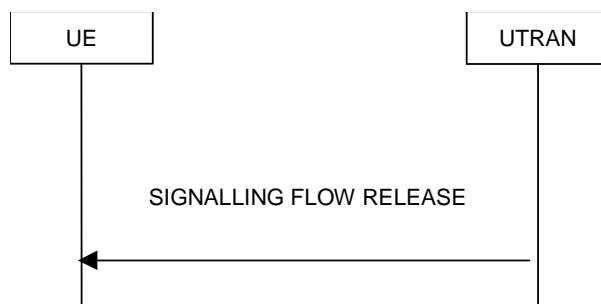

Figure 20: Signalling flow release procedure, normal case

8.1.13.1 General

The signalling connection release procedure is used to notify to the UE that one or more of its signalling flows of its ongoing signalling connections has been released. The procedure does not initiate the release of the RRC connection.

8.1.13.2 Initiation of SIGNALLING CONNECTION RELEASE by the UTRAN

The UTRAN may initiate the release of one or more signalling flows.

To initiate the procedure, the UTRAN transmits a SIGNALLING FLOW RELEASE message on DCCH using AM RLC.

The UTRAN should identify the signalling flows to be released using the IE "Flow Identifier".

8.1.13.3 Reception of SIGNALLING FLOW RELEASE by the UE

Upon reception of a SIGNALLING FLOW RELEASE message, the UE shall indicate the release of the signalling flows identified by the values of the IE "Flow identifier" to the corresponding higher layer entities.

8.1.13.4 Invalid SIGNALLING FLOW RELEASE message

If the UE receives a SIGNALLING FLOW RELEASE message, which contains a protocol error causing the variable `PROTOCOL_ERROR_REJECT` to be set to TRUE according to clause 16, the UE shall perform procedure specific error handling as follows:

- transmit an RRC STATUS message on the uplink DCCH using AM RLC;
- include the IE "Protocol error information" with contents set to the value of the variable `PROTOCOL_ERROR_INFORMATION`;
- when the successful delivery of the RRC STATUS message has been confirmed by RLC:

- resume normal operation as if the invalid SIGNALLING CONNECTION RELEASE message has not been received.

8.1.14 Signalling connection release request procedure

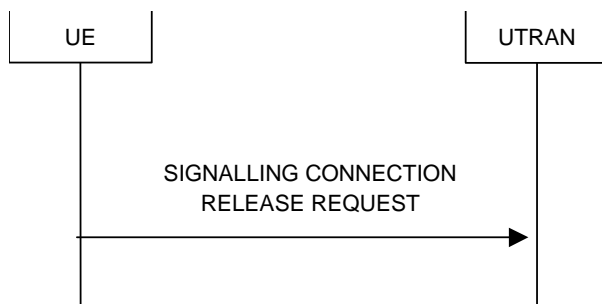

Figure 21: Signalling connection release request procedure, normal case

8.1.14.1 General

The signalling connection release request procedure is used by the UE to request from the UTRAN that one of its signalling connections should be released. The procedure may in turn initiate the signalling flow release or RRC connection release procedure.

8.1.14.2 Initiation

The UE shall initiate the signalling connection release request procedure on receiving a request from higher layers.

To initiate the procedure, the UE transmits a SIGNALLING CONNECTION RELEASE REQUEST message on DCCH using AM RLC. When the successful delivery of SIGNALLING CONNECTION RELEASE REQUEST message has been confirmed by RLC, the UE shall delete the released flow identifier(s).

The IE "Flow Identifier" indicates the signalling flow identity which is requested to be released.

8.1.14.3 Reception of SIGNALLING CONNECTION RELEASE REQUEST by the UTRAN

Upon reception of a SIGNALLING CONNECTION RELEASE REQUEST message, the UTRAN may initiate the RRC connection release procedure, if the UE has requested the release of all its remaining signalling connections. If all remaining signalling connections are not requested to be released, the UTRAN should initiate the signalling flow release procedure. In the latter case the UTRAN should include all the signalling flows identified by the "Flow identifiers", associated with the signalling connection being released.

8.1.15 Counter check

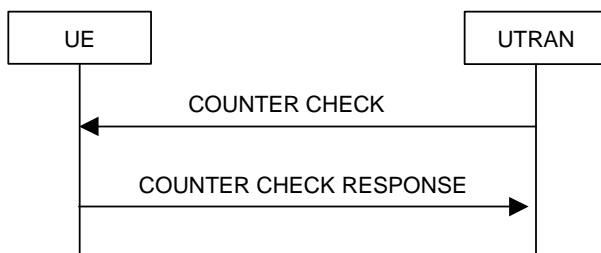

Figure 22: Counter check procedure

8.1.15.1 General

The counter check procedure is used by the UTRAN to perform a local authentication. The purpose of the procedure is to check that the amount of data sent in both directions (uplink/downlink) during the RRC connection is identical at the UTRAN and at the UE (to prevent a possible intruder – a 'man-in-the-middle' – to operate). It should be noted that this requires that the COUNT-C values for each radio bearer are maintained even if ciphering is not used. This procedure is only applicable to radio bearers using UM or AM mode of RLC. In Release 99, this procedure is not applied for radio bearers using transparent mode RLC.

8.1.15.2 Initiation

The UTRAN monitors the COUNT-C value associated with each radio bearer using UM or AM RLC. The procedure is triggered whenever any of these values reaches a critical checking value. The granularity of these checking values and the values themselves are defined to the UTRAN by the visited network. The UTRAN initiates the procedure by sending a COUNTER CHECK message on the downlink DCCH.

8.1.15.3 Reception of a COUNTER CHECK message by the UE

When the UE receives a COUNTER CHECK message it shall compare the COUNT-C MSB values received in the COUNTER CHECK message to the COUNT-C MSB values of the corresponding radio bearers.

If the number of radio bearers using UM or AM RLC mode or any of the COUNT-C MSB values is different the mismatched COUNT-C values shall be included in a COUNTER CHECK RESPONSE message.

The UE shall

- set the IE "RRC transaction identifier" in the COUNTER CHECK RESPONSE message to
- the value of "RRC transaction identifier" in the entry for the COUNTER CHECK message in the table "Accepted transactions" in the variable TRANSACTIONS, and;
- clear that entry.

The UE shall send the COUNTER CHECK RESPONSE message on the uplink DCCH using AM RLC. When the COUNTER CHECK RESPONSE message has been submitted to lower layers for transmission the procedure ends.

8.1.15.4 Reception of the COUNTER CHECK RESPONSE message by UTRAN

If the UTRAN receives a COUNTER CHECK RESPONSE message that does not contain any COUNT-C values, the procedure ends.

If the UTRAN receives a COUNTER CHECK RESPONSE message that contains one or several COUNT-C values, it should compare the COUNT-C values in the message to the COUNT-C values which were used in forming the COUNTER CHECK message.

If there is no difference or if the difference is acceptable, the procedure ends. The limits for an acceptable difference are defined to the UTRAN by the visited network.

If there is a difference that is not acceptable, UTRAN should initiate the release of the RRC connection.

8.1.15.4a Cell re-selection

If the UE performs cell re-selection anytime during this procedure it shall, without interrupting the procedure, initiate the cell update procedure according to subclause 8.3.1.

8.1.15.5 Invalid COUNTER CHECK message

If the UE receives a COUNTER CHECK message which contains a protocol error causing the variable `PROTOCOL_ERROR_REJECT` to be set to `TRUE` according to clause 16, the UE shall perform procedure specific error handling as follows:

- ~~Transmit an RRC STATUS message on the uplink DCCH using AM RLC_s and include the IE "Protocol error information" with contents set to the value of the variable PROTOCOL_ERROR_INFORMATION.~~
- ~~include the IE "Identification of received message", and;~~
 - ~~set the IE "Received message type" to COUNTER CHECK;~~
 - ~~set the IE "RRC transaction identifier" to the value of "RRC transaction identifier" in the entry for the UE COUNTER CHECK message in the table "Rejected transactions" in the variable TRANSACTIONS, and;~~
 - ~~clear that entry;~~
- ~~include the IE "Protocol error information" with contents set to the value of the variable PROTOCOL_ERROR_INFORMATION;~~
- **When the successful delivery of the RRC STATUS message has been confirmed by RLC submitted to lower layers for transmission, the UE shall resume normal operation as if the invalid COUNTER CHECK message has not been received.**

8.2.8 PUSCH capacity request [TDD only]

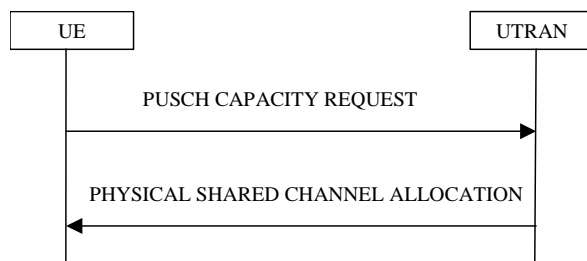

Figure 36: PUSCH Capacity request procedure

8.2.8.1 General

With this procedure, the UE transmits its request for PUSCH resources to the UTRAN. In the normal case, the UTRAN responds with a PHYSICAL SHARED CHANNEL ALLOCATION message, which either allocates the requested PUSCH resources, and/or allocates a PDSCH resource, or may just serve as an acknowledgement, indicating that PUSCH allocation is pending.

This procedure can also be used to acknowledge the reception of a PHYSICAL SHARED CHANNEL ALLOCATION message, or to indicate a protocol error in that message.

With the PUSCH CAPACITY REQUEST message, the UE can request capacity for one or more USCH.

8.2.8.2 Initiation

The UE is in the CELL_FACH or CELL_DCH state, and at least one RB using USCH has been established. The RRC in the UE sees the requirement to request physical resources (PUSCH) for an USCH channel or there is the need to reply to a PHYSICAL SHARED CHANNEL ALLOCATION message as described in clause 8.2.7 (i.e. to confirm the reception of a message, if requested to do so, or to indicate a protocol error).

The RRC decides to send a PUSCH capacity request on the SHCCH. This is possible if:

- Timer T311 is not running.
- The timer T310 (capacity request repetition timer) is not running.

So the UE sends a PUSCH CAPACITY REQUEST message on the uplink SHCCH, resets counter V310, and starts timer T310.

With one PUSCH CAPACITY REQUEST message, capacity for one or more USCH can be requested. It shall include these information elements:

- C-RNTI to be used as UE identity if the message is sent on RACH;
- Traffic volume measured results for each radio bearer satisfying the reporting criteria as specified in the MEASUREMENT CONTROL procedure (if no radio bearer satisfies the reporting criteria, traffic volume measured results shall not be included). These results shall include:
 - Radio Bearer ID of the Radio Bearer being reported;
 - RLC buffer payload for these radio bearers, as specified by the MEASUREMENT CONTROL procedure;
- If the message is sent to confirm the reception of a PHYSICAL SHARED CHANNEL ALLOCATION message, the CHOICE "Allocation confirmation" shall be included, as specified in the PHYSICAL SHARED CHANNEL ALLOCATION procedure.
- If the variable PROTOCOL_ERROR_REJECT is set to TRUE, the UE shall:
 - set the IE "protocol error indicator" to TRUE;

- include the IE "Protocol error information" with contents set to the value of the variable PROTOCOL_ERROR_INFORMATION.

As an option, the message may include "Timeslot ISCP" and "Primary CCPCH RSCP".

The timeslots for which "Timeslot ISCP" may be reported shall have been configured with a previous PHYSICAL SHARED CHANNEL ALLOCATION message.

8.2.8.3 Reception of a PUSCH CAPACITY REQUEST message by the UTRAN

Upon receiving a PUSCH CAPACITY REQUEST message with traffic volume measurement included for at least one radio bearer, the UTRAN should initiate the PHYSICAL SHARED CHANNEL ALLOCATION procedure, either for allocating PUSCH or PDSCH resources as required, or just as an acknowledgement, announcing a pending PUSCH allocation, as described in 8.2.7.

8.2.8.4 T310 time out

Upon expiry of timer T310, the UE shall

- if V310 is smaller than N310:
 - transmit a new PUSCH CAPACITY REQUEST message on the Uplink SHCCH;
 - restart timer T310;
 - ~~increase~~increment counter V310;
 - set the IEs in the PUSCH CAPACITY REQUEST message as specified above;
- if V310 is greater than or equal to N310:
 - stop the procedure.

8.3 RRC connection mobility procedures

8.3.1 Cell update

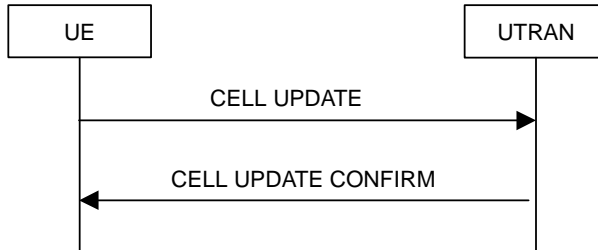

Figure 40: Cell update procedure, basic flow

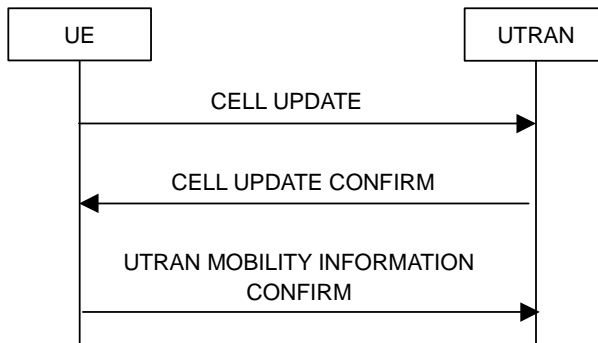

Figure 41: Cell update procedure with update of UTRAN mobility information

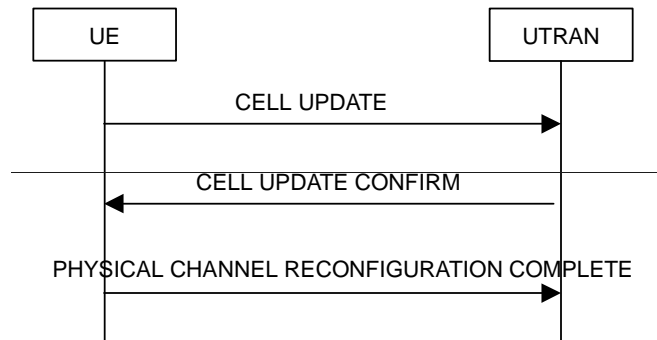

Figure 42: Cell update procedure with physical channel reconfiguration

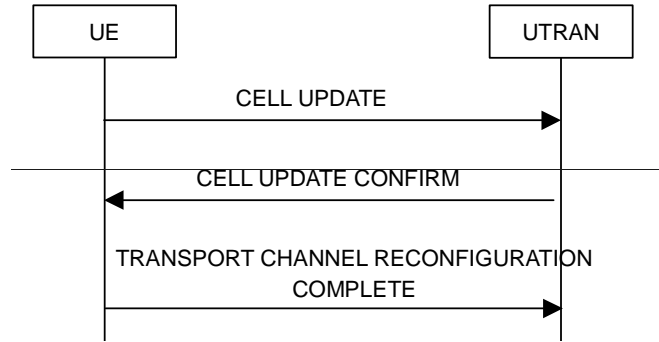

Figure 43: Cell update procedure with transport channel reconfiguration

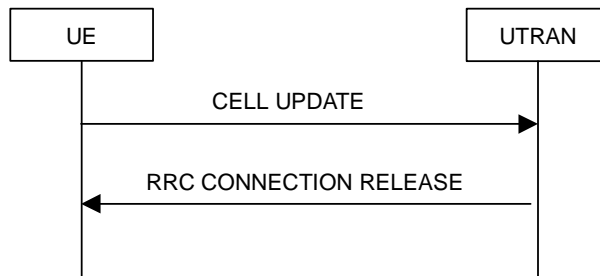

Figure 44: Cell update procedure, failure case

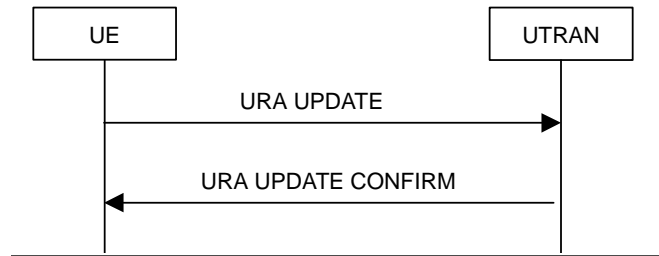

Figure 45: URA update procedure, basic flow

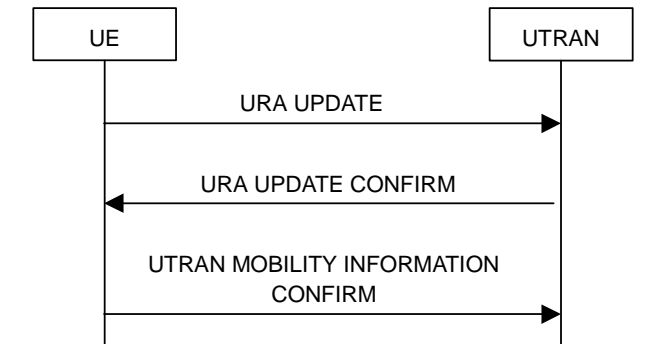

Figure 46: URA update procedure with update of UTRAN mobility information

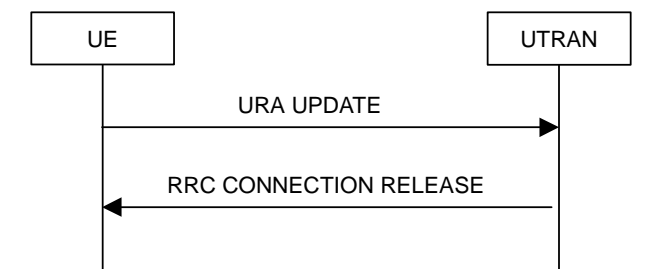

Figure 47: URA update procedure, failure case

8.3.1.1 General

The URA update and cell update procedures serves several main purposes:

- to notify UTRAN after re-entering service area in the URA_PCH or CELL_PCH state;
- to update UTRAN with the current cell the UE is camping on after cell reselection or after re-entering service area in the CELL_FACH or CELL_PCH states;
- to act on a radio link failure in the CELL_DCH state;
- to notify UTRAN of an RLC unrecoverable error on an AM RLC entity;
- to be used as a supervision mechanism in the CELL_FACH or CELL_PCH and CELL_PCH states by means of periodical cell update;
- triggered in the CELL_PCH or URA_PCH states, to notify UTRAN a transition to the CELL_FACH state due to reception of UTRAN originated paging or due to request to transmit uplink data.

The URA update procedure serves also the purpose:

- to retrieve a new URA identity after cell re-selection to a cell not belonging to the current URA assigned to the UE in URA_PCH state;

The cell update procedure serves also the purposes:

- to update UTRAN with the current cell the UE is camping on after cell reselection;
- triggered in the URA_PCH or CELL_PCH state, to notify UTRAN a transition to the CELL_FACH state due to reception of UTRAN originated paging or due to request to transmit uplink data.

The URA update and cell update procedures may include:

- a reset of AM RLC entities;
- an update of mobility related information in the UE;
- a radio bearer release, radio bearer reconfiguration, transport channel reconfiguration or physical channel reconfiguration;
- a state transition from the CELL_FACH state to the CELL_DCH, CELL_PCH or URA_PCH states or idle mode.

The cell update procedure may also include:

- a reset of AM RLC entities;

The main purpose of the cell update procedure is to update UTRAN with the current cell of the UE after cell reselection in CELL_FACH or CELL_PCH state. Secondly, the procedure may be used by the UE to indicate to the UTRAN a transition from URA_PCH or CELL_PCH state to CELL_FACH state prior to transmitting uplink data. Thirdly, the procedure may also be used for supervision of the RRC connection, even if no cell reselection takes place. The cell

update procedure can include the resetting of the AM RLC entities for the signalling link and the u-plane link. The UE can use a CELL UPDATE message to notify the unrecoverable error (Amount of the retransmission of RESET PDU reaches the value of Max DAT and receives no ACK) in an AM RLC entity for the signalling link.

NOTE: ~~PHYSICAL/TRANSPORT CHANNEL RECONFIGURATION COMPLETE~~ message is only used when common channels are configured (doesn't apply to dedicated channels)

8.3.1.2 Initiation

A UE shall initiate the cell update procedure in the following cases:

- Uplink data transmission:
 - If the UE is in URA_PCH or CELL_PCH state, and;
 - the UE has uplink data or a signalling message on RB 1 or upwards to transmit;
 - it shall perform cell update using the cause "uplink data transmission".
- Paging response:
 - If the criteria for performing cell update with the cause as specified above in the current subclause is not met, and;
 - the UE in URA_PCH or CELL_PCH and URA_PCH state, receives a PAGING TYPE 1 message fulfilling the conditions for initiating a cell update procedure specified in subclause 8.1.2.3;
 - it shall perform cell update using the cause "paging response".
- Re-entering service area:
 - If none of the criteria for performing cell update with the causes as specified above in the current subclause is met, and;
 - the UE is in CELL_FACH or CELL_PCH state, and;
 - the UE has been out of service area and re-enters service area before T307 or T317 expires;
 - it shall perform cell update using the cause "re-entering service area".
- RLC unrecoverable error:
 - If none of the criteria for performing cell update with the causes as specified above in the current subclause is met, and;
 - the UE detects RLC unrecoverable error in an AM RLC entity;
 - it shall perform cell update using the cause "RLC unrecoverable error".
- Cell reselection:
 - If none of the criteria for performing cell update with the causes as specified above in the current subclause is met, and;
 - if the UE is in CELL_FACH or CELL_PCH state, and;
 - the UE performs cell re-selection;
 - it shall perform cell update using the cause "cell reselection".
- Periodical cell update:
 - If none of the criteria for performing cell update with the causes as specified above in the current subclause is met, and;
 - the UE is in CELL_FACH or CELL_PCH state, and;

- ~~the timer T305 expires, and;~~
- ~~the criteria for "in service area" as specified in 8.5.5.28-5.9 is fulfilled, and;~~
- ~~periodic cell updating has been requested in system information block type 1;~~
- ~~it shall perform cell update using the cause "periodical cell update".~~

A UE in URA_PCH state shall initiate the URA update procedure in the following cases:

- URA reselection:
 - If the criteria for performing URA update with the cause as specified above is not met, and;
 - If the UE detects that the current URA assigned to the UE, stored in the variable URA_IDENTITY, is not present in the list of URA identities in system information block type 2;
 - the UE shall perform URA update using the cause "URA reselection".
- Periodic URA update:
 - If none of the criteria for performing cell update with the causes as specified above is met, and;
 - if the timer T305 expires
 - while the UE is in the service area, and;
 - periodic URA updating has been requested in system information block type 1;
 - the UE shall perform URA update using the cause "periodic URA update".

When initiating the URA update or cell update procedure, the UE shall :

- in the variable RB_TIMER_INDICATOR, set the IE "T314 expired" and the IE "T315 expired" to FALSE;
- stop timer T306305;
- set the variables PROTOCOL_ERROR_INDICATOR, FAILURE_INDICATOR, UNSUPPORTED_CONFIGURATION and INVALID_CONFIGURATION to FALSE;
- move to CELL_FACH state, if not already in that state;
- if the UE ~~made~~ performs cell re-selection, clear the variable C_RNTI and remove any C-RNTI from MAC;
- set CFN in relation to SFN of current cell according to 8.5.17;
- set the content of the CELL_UPDATE / URA_UPDATE message according to subclause 8.3.1.2a;
- submit the CELL_UPDATE / URA_UPDATE message for transmission on the uplink CCCH;
- reset counter V302;
- start timer T302 when the MAC layer indicates success or failure ~~to~~in transmitting the message;

8.3.1.2a CELL_UPDATE / URA_UPDATE message content to set

In case of cell update procedure the UE shall transmit a CELL_UPDATE message.

In case of URA update procedure the UE shall transmit a URA_UPDATE message.

The UE shall set the IEs in the CELL_UPDATE as follows:

- set the IE "Cell update cause" corresponding to which cause as specified in subclause 8.3.1.2 that is valid when the CELL_UPDATE message is delivered to lower layers for transmission;

NOTE: During the time period starting from when a cell update procedure is initiated by the UE until when the procedure ends, different causes may be used in different individually transmitted CELL_UPDATE messages by the UE.

- set the IE "U-RNTI" to the value of the variable U_RNTI;
- if the value of the variable PROTOCOL_ERROR_INDICATOR is TRUE:
 - include the IE "RRC transaction identifier", and;
 - set it to the value of "RRC transaction identifier" in the entry for the CELL_UPDATE_CONFIRM message in the table "Rejected transactions" in the variable TRANSACTIONS;
 - include and set the IE "failure cause" to the cause value "protocol error";
 - set the IE "Protocol error information" set to the value of the variable PROTOCOL_ERROR_INFORMATION;
- if the value of the variable FAILURE_INDICATOR is TRUE:
 - include the IE "RRC transaction identifier", and;
 - set it to the value of "RRC transaction identifier" in the entry for the CELL_UPDATE_CONFIRM message in the table "Accepted transactions" in the variable TRANSACTIONS;
 - include and set the IE "failure cause" to the value or the variable FAILURE_CAUSE;
- include the START values for each CN domain, calculated according to subclause 8.5.11;
- if an unrecoverable error in any of the AM RLC entities for the RB 2 or 3 is detected:
 - set the IE "AM_RLC error indication (for c-plane)" to TRUE;
 - otherwise set the IE "AM_RLC error indication (for c-plane)" to FALSE;
- if an unrecoverable error in any of the AM RLC entities for the RB 5 or upwards is detected:
 - set the IE "AM_RLC error indication (for u-plane)" to TRUE;
 - otherwise set the IE "AM_RLC error indication (for u-plane)" to FALSE;
- include an intra-frequency measurement report in the IE "Measured results on RACH", as specified in the IE "Intra-frequency reporting quantity for RACH reporting" and the IE "Maximum number of reported cells on RACH" in system information block type 12 (or type 11, if system information block type 12 is not being broadcast).

The UE shall set the IEs in the URA UPDATE message as follows:

- set the IE "U-RNTI" to the value of the variable U_RNTI;
- set the IE "URA update cause" corresponding to which cause as specified in subclause 8.3.2.2 that is valid when the URA UPDATE message is delivered to lower layers for transmission;

NOTE: During the time period starting from when a URA update procedure is initiated by the UE until when the procedure ends, different causes may be used in different individually transmitted URA UPDATE messages by the UE, depending on which causes are valid for the respective URA UPDATE message.

- if the value of the variable PROTOCOL_ERROR_INDICATOR is TRUE:
 - include the IE "RRC transaction identifier", and;
 - set it to the value of "RRC transaction identifier" in the entry for the URA_UPDATE_CONFIRM message in the table "Rejected transactions" in the variable TRANSACTIONS;
 - set the IE "Protocol error indicator" to TRUE;
 - include the IE "Protocol error information" set to the value of the variable PROTOCOL_ERROR_INFORMATION.
- if the value of the variable PROTOCOL_ERROR_INDICATOR is FALSE:
 - set the IE "Protocol error indicator" to FALSE.

A UE in CELL_FACH, CELL_PCH or URA_PCH state shall initiate the cell update procedure in the following cases:

- Cell reselection: In CELL_FACH or CELL_PCH state, the UE selects another cell.
- Periodic cell update: In CELL_FACH and CELL_PCH state, the timer T305 expires while the UE detects "in the service area" (as specified in 8.5.9) and periodic cell updating has been required in IE "Information for periodical cell and URA update" in System Information Block Type 2.
- RB control response: The UE receives an RB control message initiating a transition from CELL_DCH to CELL_FACH state, but the message does not indicate which cell to camp on. Consequently the UE selects a cell autonomously.
- UL data transmission: In CELL_PCH state and URA_PCH state, the UE makes a state transition to CELL_FACH state in order to transmit UL data.
- Paging response: In CELL_PCH and URA_PCH state, the UE receives a PAGING TYPE 1 message as in subclause 8.1.2.3.
- Re-entering service area: In URA_PCH state, the UE has been out of service area and re-enters service area before T307 expires.

In order to initiate the cell update procedure, the UE shall:

- set the variable `PROTOCOL_ERROR_INDICATOR` to FALSE;
- move to CELL_FACH state, if not already in that state;
- consider the stored C-RNTI to be invalid until CELL UPDATE CONFIRM message is received when UE detects a new cell;
- suspend data transmission on RB 3 and upward, if RLC-AM or RLC-UM is used on those radio bearers;
- transmit a CELL UPDATE message on the uplink CCCH;
- start timer T302 and reset counter V302.

The UE shall set the IEs in the CELL UPDATE as follows:

- indicate the reason for CELL update in the IE "CELL update cause" corresponding to the initiation cause as listed above;
- if the value of the variable `PROTOCOL_ERROR_INDICATOR` is TRUE, the UE shall set the IE "Protocol error indicator" to TRUE and include the IE "Protocol error information" set to the value of the variable `PROTOCOL_ERROR_INFORMATION`.
- if the value of the variable `PROTOCOL_ERROR_INDICATOR` is FALSE, the UE shall set the IE "Protocol error indicator" to FALSE.
- If the UE detects unrecoverable error (amount of the retransmission of RESET PDU reaches the value of Max DAT and receives no ACK) in an AM RLC entity for the signalling link, the UE shall set the IE "AM_RLC error indication". If the UE detects unrecoverable error in an AM RLC entity (for u-plane) for u-plane link, the UE shall set the IE "AM_RLC error indication (for u-plane)".
- The UE shall include the START values from each CN domain in CELL UPDATE message.

The UE shall include an intra-frequency measurement report in IE "Measured results on RACH", as specified in the IE "Intra-frequency reporting quantity for RACH reporting" and the IE "Maximum number of reported cells on RACH" in system information block type 12 (or type 11, if system information block type 12 is not being broadcast).

8.3.1.3 T305 expiry and the UE detects that it is out of service area

When the T305 expires and the UE detects that it is "out of service area" as specified in subclause 8.5.5, the UE shall

- start timer T307;
- re-select to a new cell, as described in [4].

8.3.1.3.1 Re-entering of service area

If the UE detects "in service area" according to subclause 8.5.5.28-5-9 and timer T307 or T317 is running. When the UE detects that it is no longer "out of service area" before the expiry of T307, the UE shall check the value of V302 and:

- if V302 is equal to or smaller than N302:
 - set the contents of the CELL UPDATE / URA UPDATE message according to subclause 8.3.1.2a; [Editor's note: style changed to B2]
 - ~~transmit~~ submit a the CELL UPDATE / URA UPDATE message for transmission on the uplink CCCH; [Editor's note: style changed to B2]
 - increment counter V302; [Editor's note: style changed to B2]
 - restart timer T302 when the MAC layer indicates success or failure to transmit the message; [Editor's note: style changed to B2]
- If V302 is greater than N302:
 - clear the variable RB UPLINK CIPHERING ACTIVATION TIME INFO;
 - clear the entry for the CELL UPDATE CONFIRM / URA UPDATE CONFIRM message in the table "Rejected transactions" in the variable TRANSACTIONS;
 - release all its radio resources;
 - enter idle mode;
 - a connection failure may be indicated to the non-access stratum;
 - other actions the UE shall perform when entering idle mode from connected mode are specified in subclause 8.5.2;
 - the procedure ends.

8.3.1.3.2 Expiry of timer T307

When the T307 expires, the UE shall:

- move to idle mode;
- release all dedicated resources;
- indicate an RRC connection failure to the non-access stratum.

Other actions the UE shall perform when entering idle mode from connected mode are specified in subclause 8.5.2.

8.3.1.4 Reception of an CELL UPDATE / URA UPDATE message by the UTRAN

When the UTRAN receives a CELL UPDATE / URA UPDATE message, it may either:

- in case the procedure was triggered by reception of a CELL UPDATE, transmit a CELL UPDATE CONFIRM message on the downlink DCCH or optionally on the CCCH but only if ciphering is not required; or
- in case the procedure was triggered by reception of a URA UPDATE, transmit a URA UPDATE CONFIRM message to the lower layers for transmission on the downlink CCCH or DCCH in which case the UTRAN should include the IE "URA identity" in the URA UPDATE CONFIRM message in a cell where multiple URA identifiers are broadcast; or
- initiate an RRC connection release procedure (see subclause 8.1.4) by transmitting an RRC CONNECTION RELEASE message on the downlink CCCH.

When the UTRAN detects AM_RLC unrecoverable error (Amount of the retransmission of RESET PDU reaches the value of Max DAT and receives no ACK), it waits for CELL UPDATE message from the UE and when the UTRAN receives it, UTRAN commands the UE to reset AM_RLC by sending CELL UPDATE CONFIRM message. This

~~procedure can be used not only in the case of AM_RLC unrecoverable error but also in the case that UTRAN wants to reset AM_RLC for other reasons such as in the case when SRNC Relocation is initiated without keeping RLC status (current counters) from old SRNC to new SRNC.~~

8.3.1.5 Reception of the CELL UPDATE CONFIRM / URA UPDATE CONFIRM message by the UE

~~Upon~~ When the UE receives ~~ing the a~~ CELL UPDATE CONFIRM / URA UPDATE CONFIRM message, and :

- ~~- the message is received on the CCCH, and IE "U-RNTI" is present and has the same value as the variable U_RNTI, or;~~
- ~~- the message is received on DCCH; (old C-RNTI or U-RNTI may be used for MAC header),~~

the UE shall:

- ~~- stop timer T302;~~
- ~~- act upon all received information elements as specified in 8.6, unless specified otherwise in the following:~~
 - ~~- if the CELL UPDATE CONFIRM message includes the IE "RLC reset indicator (for C-plane)" the UE shall reset the RLC entities for RB 2, RB 3 and, if present, RB 4.~~
 - ~~- if the CELL UPDATE CONFIRM message includes the IE "RLC reset indicator (for U-plane)" the UE shall reset the AM RLC entities for RB 5 and upwards.~~
- ~~- enter a state according to subclause 8.5.7 applied on the CELL UPDATE CONFIRM / URA UPDATE CONFIRM message.~~

If the UE after state transition remains CELL_FACH state, it shall

- ~~- start the timer T305 if timer T305 is not running and periodical cell update has been requested in system information block type 1;~~
- ~~- select PRACH according to subclause 8.6.6.2;~~
- ~~- select Secondary CCPCH according to subclause 8.6.6.4.~~
- ~~- if the IE "UTRAN DRX cycle length coefficient" is included in the same message:~~
 - ~~- ignore that IE and stop using DRX;~~

If the UE after state transition enters URA_PCH or CELL_PCH state, it shall

- ~~- remove any C-RNTI from MAC;~~
- ~~- clear the variable C_RNTI;~~
- ~~- start the timer T305 if timer T305 is not running and periodical URA update or cell update has been requested in system information block type 1;~~
- ~~- select Secondary CCPCH according to subclause 8.6.6.4.~~
- ~~- if the IE "UTRAN DRX cycle length coefficient" is included in the same message, use the value in the IE "UTRAN DRX Cycle length coefficient" for calculating Paging Occasion and PICH Monitoring Occasion as specified in 8.6.3.2 in CELL_PCH state.~~

If the UE after state transition enters URA_PCH state, it shall

- ~~- remove any C-RNTI from MAC;~~
- ~~- clear the variable C_RNTI;~~
- ~~- start the timer T306 if timer T306 is not running and periodical URA update has been requested in system information block type 1;~~
- ~~- select Secondary CCPCH according to subclause 8.6.6.4.~~

If

- the UE after the state transition remains in CELL_FACH state and;
- the contents of the variable C_RNTI is empty;

it shall check the value of V302 and

- If V302 is equal to or smaller than N302:
 - set the content of the CELL_UPDATE / URA_UPDATE message according to subclause 8.3.1.2a;
 - submit the CELL_UPDATE / URA_UPDATE message for transmission on the uplink CCCH;
 - increment counter V302;
 - restart timer T302 when the MAC layer indicates success or failure to transmit the message;
- If V302 is greater than N302:
 - clear the variable RB_UPLINK_CIPHERING_ACTIVATION_TIME_INFO;
 - clear the entry for the CELL_UPDATE_CONFIRM / URA_UPDATE_CONFIRM message in the table "Rejected transactions" in the variable TRANSACTIONS;
 - release all its radio resources;
 - enter idle mode.;
 - ~~The procedure ends and~~ a connection failure may be indicated to the non-access stratum.;
 - ~~Other actions the UE shall perform when entering idle mode from connected mode are specified in~~ subclause 8.5.2.;
 - the procedure ends.

If

- the UE after the state transition remains in CELL_FACH state and a C-RNTI is stored in the variable C_RNTI,
or;
- the UE after the state transition moves to another state than the CELL_FACH state;

the UE shall:

- if the variable RB_UPLINK_CIPHERING_ACTIVATION_TIME_INFO is set:
 - include and set the IE "Radio bearer uplink ciphering activation time info" in any response message transmitted below to the value of that variable;
- set the IE "RRC transaction identifier" in any response message transmitted below to:
 - the value of "RRC transaction identifier" in the entry for the CELL_UPDATE_CONFIRM message in the table "Accepted transactions" in the variable TRANSACTIONS, and;
 - clear that entry.
- if the variable PDCP_SN_INFO is non-empty:
 - include the IE "RB with PDCP information list" in any response message transmitted below and set it to the value of the variable PDCP_SN_INFO;
 - transmit a possible response message as specified in subclause 8.3.1.5a;
 - clear the variable PDCP_SN_INFO;
 - clear the variable RB_UPLINK_CIPHERING_ACTIVATION_TIME_INFO;

- clear the entry for the CELL UPDATE CONFIRM / URA UPDATE CONFIRM message in the table "Rejected transactions" in the variable TRANSACTIONS.

The procedure ends.

8.3.1.5a Transmission of a possible-response message to UTRAN

If the CELL UPDATE CONFIRM message:

- includes "CN information elements", or;
- includes the IE "New C-RNTI", or;
- includes the IE "New U-RNTI";

the UE shall

- transmit a UTRAN MOBILITY INFORMATION CONFIRM as response message using AM RLC.

If the CELL UPDATE CONFIRM message:

- does not include "CN information elements", and;
- does not include the IE "New C-RNTI", and;
- does not include the IE "New U-RNTI";

the UE shall

- transmit no response message.

If the URA UPDATE CONFIRM message:

- includes any one or both of the IEs "New C-RNTI" and "New U-RNTI";

the UE shall:

- transmit a UTRAN MOBILITY INFORMATION CONFIRM as response message using AM RLC.

If the new state is CELL_FACH, the response message shall be transmitted using the new configuration after the state transition., and:

- if the variable PDCP_SN_INFO is empty:
 - if the variable RB_UPLINK_CIPHERING_ACTIVATION_TIME_INFO is set:
 - when RLC has confirmed the successful transmission of the response message:
 - continue with the remainder of the procedure.
 - if the variable RB_UPLINK_CIPHERING_ACTIVATION_TIME_INFO is not set:
 - when RLC has been requested to transmit the response message,
 - continue with the remainder of the procedure.
- if the variable PDCP_SN_INFO non-empty:
 - when RLC has confirmed the successful transmission of the response message:
 - for each radio bearer in the variable PDCP_SN_INFO:
 - if the IE "RB started" in the variable ESTABLISHED_RABS is set to "started":
 - configure the RLC entity to "continue" for that radio bearer;
 - continue with the remainder of the procedure.

If the new state is CELL_PCH or URA_PCH, the response message shall be transmitted in CELL_FACH state, and:

- when RLC has confirmed the successful transmission of the response message:
- for each radio bearer in the variable PDCP_SN_INFO:
 - if the IE "RB started" in the variable ESTABLISHED_RABS is set to "started":
 - configure the RLC entity to "continue" for that radio bearer;
- the UE shall enter the new state (CELL_PCH or URA_PCH, respectively);
- continue with the remainder of the procedure.

In case the new state is CELL_DCH or CELL_FACH, the response message shall be transmitted using the new configuration after the state transition.

In case the new state is CELL_PCH or URA_PCH, the response message shall be transmitted using the old configuration before the state transition. When the successful delivery of the response message has been confirmed by RLC, the UE shall enter the new state (CELL_PCH or URA_PCH, respectively).

8.3.1.5ab Unsupported configuration by the UE

If the UE does not support the configuration in the CELL_UPDATE_CONFIRM message and/or the variable UNSUPPORTED_CONFIGURATION is set to TRUE, the UE shall:

- if V302 is equal to or smaller than N302, the UE shall:
 - set the variable FAILURE_INDICATOR to TRUE;
 - set the variable FAILURE_CAUSE to "Unsupported configuration";
 - set the content of the CELL_UPDATE message according to subclause 8.3.1.2a;
 - submit the CELL_UPDATE message for transmission on the uplink CCCH;
 - increment counter V302;
 - restart timer T302 when the MAC layer indicates success or failure to transmit the message;
- if V302 is greater than N302, the UE shall:
 - clear the variable RB_UPLINK_CIPHERING_ACTIVATION_TIME_INFO;
 - clear the variable PDCP_SN_INFO;
 - clear the entry for the CELL_UPDATE_CONFIRM message in the table "Rejected transactions" in the variable TRANSACTIONS;
 - release all its radio resources;
 - enter idle mode.
 - The procedure ends and a connection failure may be indicated to the non-access stratum;
 - Other actions the UE shall perform when entering idle mode from connected mode are specified in subclause 8.5.2;
 - the procedure ends.

8.3.1.5b Invalid configuration

If the variable INVALID_CONFIGURATION is set to TRUE, the UE shall:

- if V302 is equal to or smaller than N302, the UE shall:
 - set the variable FAILURE_INDICATOR to TRUE;

- set the variable FAILURE_CAUSE to "Invalid configuration";
- set the content of the CELL_UPDATE message according to subclause 8.3.1.2a;
- submit the CELL_UPDATE message for transmission on the uplink CCCH;
- increment counter V302;
- restart timer T302 when the MAC layer indicates success or failure to transmit the message;
- if V302 is greater than N302, the UE shall:
 - clear the variable RB_UPLINK_CIPHERING_ACTIVATION_TIME_INFO;
 - clear the variable PDCP_SN_INFO;
 - clear the entry for the CELL_UPDATE_CONFIRM message in the table "Rejected transactions" in the variable TRANSACTIONS;
 - release all its radio resources;
 - enter idle mode.;
 - The procedure ends and a connection failure may be indicated to the non-access stratum.;
 - Other actions the UE shall perform when entering idle mode from connected mode are specified in subclause 8.5.2.;
 - the procedure ends.

The UE shall delete old C-RNTI when a new C-RNTI is allocated. If not allocated, the UE shall use old C-RNTI as a valid C-RNTI.

The UE shall act upon all received information elements as specified in 8.6, unless specified otherwise in the following:

- if the CELL_UPDATE_CONFIRM message includes the IE "CN domain identity" and the IE "NAS system information", the UE shall forward the content of the IE "NAS system information" to the non-access stratum entity of the UE identified by the IE "CN domain identity".
- if the CELL_UPDATE_CONFIRM message includes the IE "URA-Id" the UE shall store this URA identity.
- if IE "DRX indicator" in the CELL_UPDATE_CONFIRM message is not set to "no-DRX", no RRC response message is sent to the UTRAN.
- if the CELL_UPDATE_CONFIRM message does not include IE "new C-RNTI", IE "new U-RNTI", IE "PRACH info" nor IE "Secondary CCPCH info", following actions are taken:
 - if cell update is due to "periodical cell update", no RRC response message is sent to the UTRAN.
 - if cell update is due to "UL data transmission" or "paging response" and if there is no difference in TFS and/or TFCS stored in UE compared to that for the PRACH/SCCPCH indicated in the broadcast system information, PHYSICAL_CHANNEL_RECONFIGURATION_COMPLETE message is sent to the UTRAN using the PRACH indicated in the broadcast system information.
 - if cell update is due to "UL data transmission" or "paging response" and if there is a difference in TFS and/or TFCS stored in UE compared to PRACH/SCCPCH indicated in the broadcast system information,, TRANSPORT_CHANNEL_RECONFIGURATION_COMPLETE message is sent to the UTRAN using the PRACH indicated in the broadcast system information.
 - no case for cell update due to "cell reselection" or "RB control response".
- if the CELL_UPDATE_CONFIRM message includes the IE "new C-RNTI" and optionally the IE "new U-RNTI" but does not include IE "PRACH info" or IE "Secondary CCPCH info", the UE shall update its identities and following actions are taken:
 - if cell update is due to "periodical cell update", transmit a UTRAN_MOBILITY_INFORMATION_CONFIRM message on the uplink DCCH using the PRACH stored in the UE.

- if cell update is due to "cell reselection", "UL data transmission" or "paging response" and if there is no difference in TFS and/or TFCS stored in UE compared to PRACH/SCCPCH indicated in the broadcast system information, PHYSICAL CHANNEL RECONFIGURATION COMPLETE message is sent to the UTRAN using the PRACH indicated in the broadcast system information.
- if cell update is due to "UL data transmission" or "paging response" and if there is a difference in TFS and/or TFCS stored in UE compared to PRACH/SCCPCH indicated in the broadcast system information,, TRANSPORT CHANNEL RECONFIGURATION COMPLETE message is sent to the UTRAN using the PRACH indicated in the broadcast system information.
- if cell update is due to "RB control response", transmit a RB control response message on the uplink DCCH using the PRACH indicated in the broadcast system information.
- if the CELL UPDATE CONFIRM message includes the IE "RLC reset indicator (for C-plane)" the UE shall reset the AM RLC entities on C-plane.
- if the CELL UPDATE CONFIRM message includes the IE "RLC reset indicator (for U-plane)" the UE shall reset the AM RLC entities on U-plane.
- if the CELL UPDATE CONFIRM message includes the IE "PRACH info" and/or the IE "Secondary CCPCH info", the UE shall
 - perform the actions stated in subclauses 8.6.6.2 and 8.6.6.3.
 - update its identities if the CELL UPDATE CONFIRM message includes the IE "new C-RNTI" and optionally the IE "new U-RNTI".
 - if cell update is due to "periodical cell update", "cell reselection", "UL data transmission" or "paging response", transmit a PHYSICAL CHANNEL RECONFIGURATION COMPLETE message on the uplink DCCH using the PRACH indicated in CELL UPDATE CONFIRM message.
 - if cell update is due to "RB control response", transmit a RB control response message on the uplink DCCH using the PRACH indicated in the broadcast system information.

The UE shall enter a state according to subclause 8.5.7 applied on the CELL UPDATE CONFIRM message.

In case the UE transits to CELL_FACH or CELL_PCH state and periodic cell updating is configured, it shall reset timer T305.

In case the UE does not transit to CELL_FACH state, it shall delete its C-RNTI and PRACH/SCCPCH information.

If the UE remains in CELL_FACH state and the CELL UPDATE CONFIRM message includes the IE "New C-RNTI" the UE shall then resume data transmission on RB 3 and upward, if RLC-AM or RLC-UM is used on those radio bearers:

8.3.1.X Confirmation error of URA ID list

If the URA UPDATE CONFIRM message causes a confirmation error of URA identity list as specified in subclause 8.6.2.1 the UE shall check the value of V302, and:

- if V302 is smaller or equal than N302:
 - set the IEs in the URA UPDATE message according to subclause 8.3.2.2a;
 - submit the URA UPDATE message for transmission on the uplink CCCH;
 - increment counter V302;
 - restart timer T302 when the MAC layer indicates success or failure to transmit the message;
- if V302 is greater than N302:
 - enter idle mode;
 - perform the actions specified in subclause 8.5.2 when entering idle mode from connected mode;

- a connection failure may be indicated to the non-access stratum;
- the procedure ends.

8.3.1.6 Invalid CELL UPDATE CONFIRM / URA UPDATE CONFIRM message

If the UE receives an CELL UPDATE CONFIRM / URA UPDATE CONFIRM message, which contains a protocol error causing the variable `PROTOCOL_ERROR_REJECT` to be set to TRUE according to clause 16, the UE shall perform procedure specific error handling as follows:

- If V302 is equal to or smaller than N302, the UE shall:
 - set the variable `PROTOCOL_ERROR_INDICATOR` to TRUE,
 - set the content of the CELL UPDATE / URA UPDATE message according to subclause 8.3.1.2a;
 - submit the CELL UPDATE message for transmission on the uplink CCCH;
 - increment counter V302;
 - restart timer T302 when the MAC layer indicates success or failure to transmit the message;
- if V302 is greater than N302, the UE shall:
 - clear the variable `RB_UPLINK_CIPHERING_ACTIVATION_TIME_INFO`;
 - clear the entry for the CELL UPDATE CONFIRM / URA UPDATE CONFIRM message in the table "Rejected transactions" in the variable `TRANSACTIONS`;
 - release all its radio resources;
 - enter idle mode.;
 - The procedure ends and a connection failure may be indicated to the non-access stratum.;
 - Other actions the UE shall perform when entering idle mode from connected mode are specified in subclause 8.5.2.;
- the procedure ends.

The UE shall check the value of V302 and

- If V302 is equal to or smaller than N302, the UE shall set the variable `PROTOCOL_ERROR_INDICATOR` to TRUE, retransmit a CELL UPDATE message on the uplink CCCH, restart timer T302 and increase counter V302. The IE "Cell update cause" shall be set to the event causing the transmission of the CELL UPDATE message, see subclause 8.3.1.2.
- If V302 is greater than N302, the UE shall enter idle mode. The procedure ends and a connection failure may be indicated to the non-access stratum. Other actions the UE shall perform when entering idle mode from connected mode are specified in subclause 8.5.2.

8.3.1.7 T302 expiry, or URA reselection, cell reselection

If any or several of the following conditions are true:

- expiry of timer T302;
- reselection to another UTRA cell (including the previously serving cell) when waiting for the CELL UPDATE CONFIRM / URA UPDATE CONFIRM message,
- the UE failed to establish the dedicated channel according to the CELL UPDATE CONFIRM message,

the UE shall re-check whether it is still in "in service area" (see 8.5.5.2).

Upon expiry of timer T302; and/or upon reselection to another UTRA cell (including the previously serving cell) when waiting for the CELL UPDATE CONFIRM message, and/or if the UE failed to establish the dedicated channel

~~according to the CELL UPDATE CONFIRM message, the UE shall re-check whether it is still in "in service area" (see 8.5.9).~~

~~If the UE detects "in service area", and:~~

- ~~- if V302 is equal to or smaller than N302, the UE shall~~
 - ~~- if the UE made cell re-selection, delete its C-RNTI;~~
 - ~~- set the contents of the CELL UPDATE / URA UPDATE message according to subclause 8.3.1.2a;~~
 - ~~- submit the CELL UPDATE / URA UPDATE message for transmission on the uplink CCCH;~~
 - ~~- increment counter V302;~~
 - ~~- restart timer T302 when the MAC layer indicates success or failure to transmit the message;~~
- ~~- if V302 is greater than N302, the UE shall:~~
 - ~~- clear the variable RB_UPLINK_CIPHERING_ACTIVATION_TIME_INFO;~~
 - ~~- clear the variable PDCP_SN_INFO;~~
 - ~~- clear the entry for the CELL UPDATE CONFIRM / URA UPDATE CONFIRM message in the table "Rejected transactions" in the variable TRANSACTIONS;~~
 - ~~- release all its radio resources;~~
 - ~~- enter idle mode;~~
 - ~~- The procedure ends and a connection failure may be indicated to the non-access stratum;~~
 - ~~- Other actions the UE shall perform when entering idle mode from connected mode are specified in subclause 8.5.2;~~
 - ~~- the procedure ends.~~

~~If the UE does not detect "in service area", it shall:~~

- ~~- continue searching for "in service area".~~

~~the UE shall check the value of V302 and:~~

- ~~— if V302 is equal to or smaller than N302, the UE shall retransmit a CELL UPDATE message on the uplink CCCH, restart timer T302 and increase counter V302. The IE "Cell update cause" shall be set to the event causing the transmission of the CELL UPDATE message, see subclause 8.3.1.2.~~
- ~~— if V302 is greater than N302, the UE shall enter idle mode. The procedure ends and a connection failure may be indicated to the non-access stratum. Other actions the UE shall perform when entering idle mode from connected mode are specified in subclause 8.5.2~~

8.3.1.8 Reception of the UTRAN MOBILITY INFORMATION CONFIRM message by the UTRAN

See subclause 8.3.3.4.

~~8.3.1.9 Reception of the PHYSICAL CHANNEL RECONFIGURATION COMPLETE message by the UTRAN~~

~~When the UTRAN receives PHYSICAL CHANNEL RECONFIGURATION message, the procedure ends.~~

~~8.3.1.10 Reception of the TRANSPORT CHANNEL RECONFIGURATION COMPLETE message by the UTRAN~~

~~When the UTRAN receives TRANSPORT CHANNEL RECONFIGURATION message, the procedure ends.~~

8.3.2 URA update

See subclause 8.3.1.

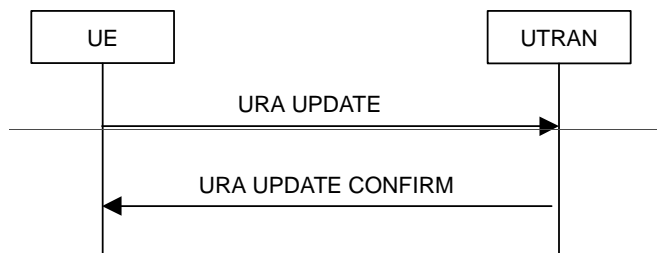

Figure 45: URA update procedure, basic flow

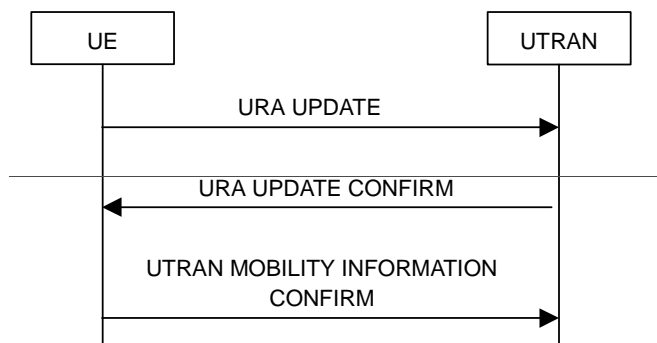

Figure 46: URA update procedure with update of UTRAN mobility information update

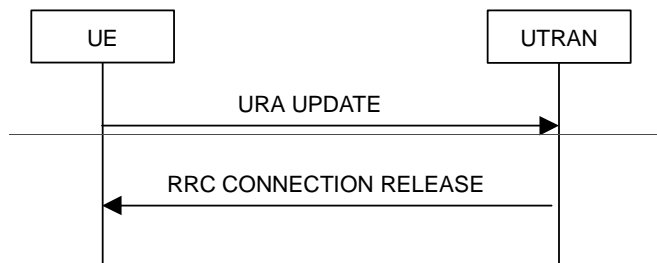

Figure 47: URA update procedure, failure case

8.3.2.1 General

The URA update procedure serves several main purposes:

- to retrieve a new URA identity after cell re-selection to a cell not belonging to the current URA assigned to the UE in URA_PCH state;
- to notify UTRAN after re-entering service area in the URA_PCH state;
- to notify UTRAN of an RLC unrecoverable error on an AM RLC entity;
- to be used as a supervision mechanism in the URA_PCH states by means of periodical URA update;

The cell update procedure may include:

- an update of mobility related information in the UE;
- a state transition from the CELL_FACH state to the CELL_PCH or URA_PCH states or idle mode.

The main purpose of the URA update procedure is to update ~~the UTRAN UE~~ with the current URA of the UE after URA reselection in URA_PCH state. It may also be used for supervision of the RRC connection, even if no URA reselection takes place ~~[how, not part of triggers listed below? Periodical URA update]~~. UTRAN registration areas may be hierarchical ~~configured in an overlapping fashion to avoid excessive signalling~~. This means that several URA identifiers may be broadcast in one cell and that different UEs in one cell may reside in different URAs. A UE in URA_PCH state shall always have one and only one valid URA. The URA UPDATE CONFIRM message may also contain new NAS system information.

8.3.2.2 ~~Initiation~~

A UE in URA_PCH state shall initiate the URA update procedure in the following cases:

- ~~— Re-entering service area:~~
 - ~~— If the UE has been out of service area and re-enters service area before T307 expires;~~
 - ~~— the UE shall perform URA update using the cause “re-entering service area”;~~
- ~~— URA reselection:~~
 - ~~— If the criteria for performing URA update with the cause as specified above is not met, and;~~
 - ~~— If the UE detects that the current URA assigned to the UE, stored in the variable URA_IDENTITY, is not present in the list of URA identities in system information block type 2;~~
 - ~~— the UE shall perform URA update using the cause “URA reselection”;~~
- ~~— Periodic URA update:~~
 - ~~— If none of the criteria for performing cell update with the causes as specified above is met, and;~~
 - ~~— if the timer T306 expires~~
 - ~~— while the UE is in the service area, and;~~
 - ~~— periodic URA updating has been requested in system information block type 1;~~
 - ~~— the UE shall perform URA update using the cause “periodic URA update”;~~
- ~~— URA reselection: In URA_PCH state, the UE detects that the current URA assigned to the UE is not present in the list of URA IDs broadcast in a cell.~~
- ~~— Periodic URA update: In URA_PCH state, the timer T306 expires while the UE is in the service area and periodic URA updating has been required in the IE "Information for periodical cell and URA update" in System Information Block Type 2. The UE shall initially start timer T306 upon entering URA_PCH state.~~
- ~~— Re-entering service area: In URA_PCH state, the UE has been out of service area and re-enters service area before T307 expires.~~

In order to initiate the URA update ~~procedure~~ procedure, the UE shall:

- ~~— set the variable PROTOCOL_ERROR_INDICATOR to FALSE;~~
- ~~— move to CELL_FACH state;~~
- ~~— set CFN in relation to SFN of current cell according to 8.5.17;~~
- ~~— set the content of the URA UPDATE message according to subclause 8.3.2.2a;~~
- ~~— submit a URA UPDATE message to the lower layers for transmission on the uplink CCCH;~~
- ~~— transmit a URA UPDATE message on the uplink CCCH;~~
- ~~— reset counter V303;~~
- ~~— start timer T303 when the MAC layer indicates success or failure to transmit the message;~~

— start timer T303 and reset counter V303.

8.3.2.2a URA UPDATE message content to set

The UE shall set the IEs in the URA UPDATE message as follows:

— set the IE "U-RNTI" to the value of the variable U-RNTI;

— set the IE "URA update cause" corresponding to which cause as specified in subclause 8.3.2.2 that is valid when the URA UPDATE message is delivered to lower layers for transmission;

NOTE: During the time period starting from when a URA update procedure is initiated by the UE until when the procedure ends, different causes may be used in different individually transmitted URA UPDATE messages by the UE, depending on which causes that are valid for the individual respective URA UPDATE messages.

— indicate the reason for URA update in the IE "URA update cause" corresponding to the initiation cause as listed above in this subclause;

— if the value of the variable PROTOCOL_ERROR_INDICATOR is TRUE:

— include the IE "RRC transaction identifier", and;

— set it to the value of "RRC transaction identifier" in the entry for the URA UPDATE CONFIRM message in the table "Rejected transactions" in the variable TRANSACTIONS;

— set the IE "Protocol error indicator" to TRUE;

— include the IE "Protocol error information" set to the value of the variable PROTOCOL_ERROR_INFORMATION;

— if the value of the variable PROTOCOL_ERROR_INDICATOR is FALSE:

— set the IE "Protocol error indicator" to FALSE.

— submit a URA UPDATE message to the lower layers for transmission on the uplink CCCH;

— reset counter V303 and start timer T303 when the URA UPDATE message is sent on the radio interface.

8.3.2.3 T306 expiry and the UE detects that it is out of service area

When the T306 expires and the UE detects that it is out of service area, which is as specified in subclause 8.5.5, the UE shall:

— start timer T307;

— perform cell reselection, as described in [4];

— re-select to a new cell, as described in [4]. 8.3.2.3.1 Re-entering of service area

8.3.2.3.1 Re-entering of service area

When the UE detects that it is no longer out of service area as specified in subclause 8.5.5 and before the expiry of T307 has not expired, the UE shall:

— set the IEs in the URA UPDATE message according to subclause 8.3.2.2a;

— transmit submit a URA UPDATE message to the lower layers for transmission on the uplink CCCH;

— reset counter V303;

— start timer T303 when the MAC layer indicates success or failure to transmit the message;

— reset counter V303 and start timer T303 when the URA UPDATE message is sent on the radio interface

8.3.2.3.2 Expiry of timer T307

When the T307 expires, the UE shall:

- move to idle state; mode;
- release all dedicated resources;
- indicate an RRC connection failure to the non-access stratum;
- perform actions specified in subclause 8.5.2 when entering idle mode from connected mode.

Other actions the UE shall perform when entering idle mode from connected mode are specified in subclause 8.5.2.

8.3.2.4 Reception of an URA UPDATE message by the UTRAN

When the UTRAN receives a URA UPDATE message, it may either

- transmit submit a URA UPDATE CONFIRM message to the lower layers for transmission on the downlink CCCH or DCCH. Thein which case the UTRAN should include the IE "URA identity" in the URA UPDATE CONFIRM message in a cell where multiple URA identifiers are valid broadcast; or
- initiate an RRC connection release procedure (see subclause 8.1.4) by transmitting submitting an RRC CONNECTION RELEASE message to the lower layers for transmission on the downlink CCCH.

8.3.2.5 Reception of an URA UPDATE CONFIRM message by the UE

[Hans, Indentation changes] Upon If the UE receivesing the an URA UPDATE CONFIRM message, and;

- the message is received on the CCCH, and IE "U-RNTI" is present and has the same value as the variable U-RNTI, or;
- the message is received on DCCH;

the UE shall;

- stop timer T303 and restart timer T306;

act on received information elements according to subclause 8.6;

. If if the URA UPDATE CONFIRM message includes any one of the following:

- the IEs "new C-RNTI"
- and optionally the IE "new U-RNTI",
- or both the IEs "new C-RNTI" and "new U-RNTI", the UE shall:
 - update its identities[ERA1];
 - set the IE "RRC transaction identifier" in the UTRAN MOBILITY INFORMATION CONFIRM message to
 - the value of "RRC transaction identifier" in the entry for the URA UPDATE CONFIRM message in the table "Accepted transactions" in the variable TRANSACTIONS, and;
 - clear that entry;
 - if the variable RB-UPLINK-CIPHERING-ACTIVATION-TIME-INFO is set:
 - include and set the IE "Radio bearer uplink ciphering activation time info" in the UTRAN MOBILITY INFORMATION CONFIRM message to the value of that variable;
 - if the variable PDCP-SN-INFO is non-empty;

- ~~— include the IE “RB with PDCP information list” in the UTRAN MOBILITY INFORMATION CONFIRM message and set it to the value of the variable PDCP_SN_INFO;~~
- ~~— transmit and submit a UTRAN MOBILITY INFORMATION CONFIRM message to the lower layers for transmission on the uplink DCCH using the PRACH indicated in the broadcast system information.~~
- ~~— If if the URA UPDATE CONFIRM message includes the IEs “CN domain identity” and “NAS system information”, the UE shall forward the content of the IE to the non-access stratum entity of the UE indicated by the IE “CN domain identity”.~~
- ~~— The UE shall enter a state [when? after receiving RLC confirm for UTRAN MOBILITY INFORMATION CONFIRM?] according to subclause 8.5.7 applied on the URA UPDATE CONFIRM message;, unless otherwise specified below:~~
 - ~~— If the new state is CELL_FACH:~~
 - ~~— if the variable PDCP_SN_INFO is empty, and;~~
 - ~~— if the variable RB_UPLINK_CIPHERING_ACTIVATION_TIME_INFO is set:~~
 - ~~— when RLC has confirmed the successful transmission of the UTRAN MOBILITY INFORMATION CONFIRM message, perform the actions below:~~
 - ~~— if the variable RB_UPLINK_CIPHERING_ACTIVATION_TIME_INFO is not set:~~
 - ~~— when RLC has been requested to transmit the UTRAN MOBILITY INFORMATION CONFIRM message, perform the actions below:~~
 - ~~— if the variable PDCP_SN_INFO non-empty:~~
 - ~~— when RLC has confirmed the successful transmission of the UTRAN MOBILITY INFORMATION CONFIRM message:~~
 - ~~— for each radio bearer in the variable PDCP_SN_INFO:~~
 - ~~— if the IE “RB started” in the variable ESTABLISHED_RABS is set to “started”:~~
 - ~~— configure the RLC entity for that radio bearer to continue;~~
 - ~~— stop timer T306;~~
 - ~~— if the new state is CELL_PCH:~~
 - ~~— transmit the UTRAN MOBILITY INFORMATION CONFIRM message in CELL_FACH state;~~
 - ~~— when the successful delivery of the UTRAN MOBILITY INFORMATION CONFIRM message has been confirmed by lower layers:~~
 - ~~— for each radio bearer in the variable PDCP_SN_INFO:~~
 - ~~— if the IE “RB started” in the variable ESTABLISHED_RABS is set to “started”:~~
 - ~~— configure the RLC entity for that radio bearer to continue;~~
 - ~~— remove any C-RNTI from MAC;~~
 - ~~— clear the variable C-RNTI;~~
 - ~~— select Secondary CCPCH according to subclause 8.6.6.4;~~
 - ~~— transit to CELL_PCH state;~~
 - ~~— stop timer T306;~~
 - ~~— start timer T305 if timer T305 is not running;~~
- ~~— If if the UE transits back to new state is URA_PCH state, the UE shall:~~

- ~~— transmit the UTRAN MOBILITY INFORMATION message in CELL_FACH state;~~
- ~~— when the successful delivery of the UTRAN MOBILITY INFORMATION message has been confirmed by lower layers:~~
 - ~~— for each radio bearer in the variable PDCP_SN_INFO:~~
 - ~~— if the IE “RB started” in the variable ESTABLISHED_RABS is set to “started”;~~
 - ~~— configure the RLC entity for that radio bearer to continue;~~
 - ~~— retrieve secondary CCPCH info (for the selected PCH) from the SYSTEM INFORMATION broadcast from the new cell;~~
 - ~~— delete itsremove any C-RNTI from MAC;~~
 - ~~— clear the variable C_RNTI; and~~
 - ~~— select Secondary CCPCH according to subclause 8.6.6.4;~~
 - ~~— transit to URA_PCH state;~~
 - ~~— start timer T306 if timer T306 is not running and periodical URA update has been requested in system information block type 1;~~
- ~~— clear the variable PDCP_SN_INFO;~~
- ~~— clear the variable RB_UPLINK_CIPHERING_ACTIVATION_TIME_INFO;~~
- ~~— clear the entry for the URA_UPDATE_CONFIRM message in the table “Rejected transactions” in the variable TRANSACTIONS;~~
- ~~— The procedure ends.~~

8.3.2.6 ~~Confirmation error of URA ID list~~

If the URA_UPDATE_CONFIRM message causes a confirmation error of URA identity list as specified in subclause 8.6.2.1 the UE shall check the value of V303, and:

- ~~— if V303 is smaller or equal than N303:~~
 - ~~— set the IEs in the URA_UPDATE message according to subclause 8.3.2.2a;~~
 - ~~— retransmit submit thea URA_UPDATE message for transmission on the uplink CCCH;~~
 - ~~— increment counter V303; and~~
 - ~~— restart timer T303 when the MAC layer indicates success or failure to transmit the message;~~
 - ~~— increase counter V303;~~
 - ~~— set the IEs in the URA_UPDATE message according to subclause 8.3.2.2.~~
- ~~— if V303 is greater than N303:~~
 - ~~— enter idle mode;. The procedure ends and a connection failure may be indicated to the non-access stratum. Other actions the UE shall perform when entering idle mode from connected mode are specified in subclause 8.5.2~~
 - ~~— perform the actions specified in subclause 8.5.2 when entering idle mode from connected mode.;~~
 - ~~— The procedure ends and a connection failure may be indicated to the non-access stratum.;~~
 - ~~— the procedure ends.~~

8.3.2.7 Invalid URA UPDATE CONFIRM message

If the UE receives an URA UPDATE CONFIRM message, which contains a protocol error causing the variable `PROTOCOL_ERROR_REJECT` to be set to `TRUE` according to clause 16, the UE shall perform procedure specific error handling as follows:

The UE shall check the value of `V303` and:

- if `V303` is smaller or equal than `N303`:
 - set the variable `PROTOCOL_ERROR_INDICATOR` to `TRUE`;
 - set the IEs in the URA UPDATE message according to subclause 8.3.2.2a;
 - retransmit submit at the URA UPDATE message for transmission on the uplink CCCH;
 - increment counter `V303`; and
 - restart timer `T303` when the MAC layer indicates success or failure to transmit the message when the new URA UPDATE message is sent on the radio interface.;
 - increase counter `V303`;
 - update the IEs in the URA UPDATE message according to subclause 8.3.2.2.
- If `V303` is greater than `N303`:
 - enter idle mode;. The procedure ends and a connection failure may be indicated to the non-access stratum. Other actions the UE shall perform when entering idle mode from connected mode are specified in subclause 8.5.2.
 - perform the actions specified in subclause 8.5.2 when entering idle mode from connected mode.;
 - The procedure ends and a connection failure may be indicated to the non-access stratum.;
 - the procedure ends

8.3.2.8 T303 expiry or URA reselection

- Upon expiry of timer `T303`; and/or
- upon reselection to another UTRA cell (including the previously serving cell) when waiting for the URA UPDATE CONFIRM message,

If any or both of the following conditions are true:

- expiry of timer `T303` and/or
- reselection to another UTRA cell (including the previously serving cell) when waiting for the URA UPDATE CONFIRM message,

the UE shall check the value of `V303` and:

- if `V303` is smaller or equal than `N303`:
 - set the IEs in the URA UPDATE message according to subclause 8.3.2.2a;
 - retransmit submit the URA UPDATE message for transmission on the uplink CCCH;
 - increment counter `V303`; and
 - restart timer `T303` when the MAC layer indicates success or failure to transmit the message when the new URA UPDATE message is sent on the radio interface.;
 - increase counter `V303`;
 - set the IEs in the URA UPDATE message according to subclause 8.3.2.2.

- ~~— if V303 is greater than N303:~~
- ~~— enter idle mode₁. The procedure ends and a connection failure may be indicated to the non-access stratum. Other actions the UE shall perform when entering idle mode from connected mode are specified in subclause 8.5.2₁.~~
- ~~— perform the actions specified in subclause 8.5.2 when entering idle mode from connected mode.~~
- ~~— The procedure ends and a connection failure may be indicated to the non-access stratum.~~
- ~~— the procedure ends.~~

~~8.3.2.9 Reception of the UTRAN MOBILITY INFORMATION CONFIRM message by the UTRAN~~

See subclause 8.3.3.4.

8.3.3 UTRAN mobility information

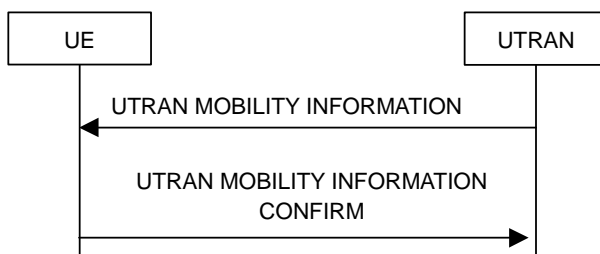

Figure 48: UTRAN mobility information procedure, normal flow

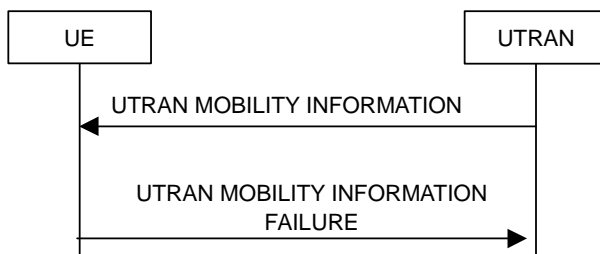

Figure 49: UTRAN mobility information procedure, failure case

8.3.3.1 General

The purpose of this procedure is to allocate any one or a combination of the following to a UE in connected mode:

- ~~- a new C-RNTI₁~~
- ~~- and/or a new U-RNTI~~
- ~~- and other UTRAN mobility related information to an UE in connected mode.~~

8.3.3.2 Initiation

To initiate the procedure UTRAN transmits a UTRAN MOBILITY INFORMATION message to the UE on the downlink DCCH.

8.3.3.3 Reception of UTRAN MOBILITY INFORMATION message by the UE

When the UE receives a UTRAN MOBILITY INFORMATION message, it shall: ~~take the following actions and then transmit a UTRAN MOBILITY INFORMATION CONFIRM message on the uplink DCCH.~~

- ~~act on received information elements as specified in subclause 8.6;~~
- ~~set the IE "RRC transaction identifier" in the UTRAN MOBILITY INFORMATION CONFIRM message to~~
 - ~~the value of "RRC transaction identifier" in the entry for the UTRAN MOBILITY INFORMATION message in the table "Accepted transactions" in the variable TRANSACTIONS, and;~~
 - ~~clear that entry.~~
- ~~if the variable RB UPLINK CIPHERING ACTIVATION TIME INFO is set:~~
 - ~~include and set the IE "Radio bearer uplink ciphering activation time info" in the UTRAN MOBILITY INFORMATION CONFIRM message to the value of that variable;~~
- ~~if the variable PDCP_SN_INFO is non-empty:~~
 - ~~include the IE "RB with PDCP information list" in the UTRAN MOBILITY INFORMATION CONFIRM message and set it to the value of the variable PDCP_SN_INFO;~~
- ~~transmit a UTRAN MOBILITY INFORMATION CONFIRM message on the uplink DCCH using AM RLC~~
- ~~transmit a UTRAN MOBILITY INFORMATION CONFIRM message on the uplink DCCH using AM RLC;~~
- ~~if the variable PDCP_SN_INFO is empty, and:~~
 - ~~if the variable RB UPLINK CIPHERING ACTIVATION TIME INFO is set:~~
 - ~~when RLC has confirmed the successful transmission of the UTRAN MOBILITY INFORMATION CONFIRM message, perform the actions below.~~
 - ~~if the variable RB UPLINK CIPHERING ACTIVATION TIME INFO is not set:~~
 - ~~when RLC has been requested to transmit the UTRAN MOBILITY INFORMATION CONFIRM message, perform the actions below.~~
 - ~~if the variable PDCP_SN_INFO non-empty:~~
 - ~~when RLC has confirmed the successful transmission of the UTRAN MOBILITY INFORMATION CONFIRM message:~~
 - ~~for each radio bearer in the variable PDCP_SN_INFO:~~
 - ~~if the IE "RB started" in the variable ESTABLISHED_RABS is set to "started":~~
 - ~~configure the RLC entity for that radio bearer to "continue";~~

~~The procedure ends when the successful delivery of the UTRAN MOBILITY INFORMATION CONFIRM message has been confirmed by RLC submitted to lower layers for transmission.~~

~~If the IE "new U-RNTI" is present, the UE shall store and start to use the values of these IEs as the current U-RNTI.~~

~~If the IE "new C-RNTI" is present, the UE shall store and start to use the value of this IE.~~

~~If neither IE "new U-RNTI" nor IE "new C-RNTI" are present, the UE shall retain previously allocated U-RNTI and C-RNTI values.~~

~~Other information elements are handled as specified in section 8.6.~~

8.3.3.4 Reception of an UTRAN MOBILITY INFORMATION CONFIRM message by the UTRAN

When the network receives UTRAN MOBILITY INFORMATION CONFIRM message, UTRAN may delete any old C-RNTI and old U-RNTI. The procedure ends.

8.3.3.4a Cell re-selection

If the UE performs cell re-selection, the UE shall:

- initiate a cell update procedure according to subclause 8.3.1;
- if the UTRAN MOBILITY INFORMATION message contains the IE "New C-RNTI", and;
 - if the UE has not yet submitted the UTRAN MOBILITY INFORMATION CONFIRM message to lower layers for transmission;
 - transmit a UTRAN MOBILITY INFORMATION FAILURE message on the uplink DCCH using AM RLC;
 - set the IE "RRC transaction identifier" in the UTRAN MOBILITY INFORMATION FAILURE message to
 - the value of "RRC transaction identifier" in the entry for the UTRAN MOBILITY INFORMATION message in the table "Accepted transactions" in the variable TRANSACTIONS, and;
 - clear that entry.
 - set the IE "failure cause" to the cause value "cell reselection";
 - when the UTRAN MOBILITY INFORMATION FAILURE message has been submitted to lower layers for transmission:
 - resume normal operation as if the invalid UTRAN MOBILITY INFORMATION message has not been received and the procedure ends.
- otherwise;
 - continue the procedure normally.

8.3.3.5 Invalid UTRAN MOBILITY INFORMATION message

If the UTRAN MOBILITY INFORMATION message contains a protocol error causing the variable PROTOCOL_ERROR_REJECT to be set to TRUE according to clause 16, the UE shall perform procedure specific error handling as follows:

- transmit a UTRAN MOBILITY INFORMATION FAILURE message on the uplink DCCH using AM RLC;
- set the IE "RRC transaction identifier" in the UTRAN MOBILITY INFORMATION FAILURE message to
 - the value of "RRC transaction identifier" in the entry for the UTRAN MOBILITY INFORMATION message in the table "Rejected transactions" in the variable TRANSACTIONS, and;
 - clear that entry.
- set the IE "failure cause" to the cause value "protocol error";
- include the IE "Protocol error information" with contents set to the value of the variable PROTOCOL_ERROR_INFORMATION;
- when the successful delivery of the UTRAN MOBILITY INFORMATION FAILURE message has been confirmed by RLC submitted to lower layers for transmission:
 - resume normal operation as if the invalid UTRAN MOBILITY INFORMATION message has not been received and the procedure ends.

8.3.4 Active set update

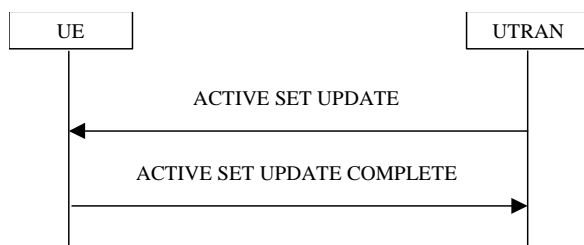

Figure 50: Active Set Update procedure, successful case

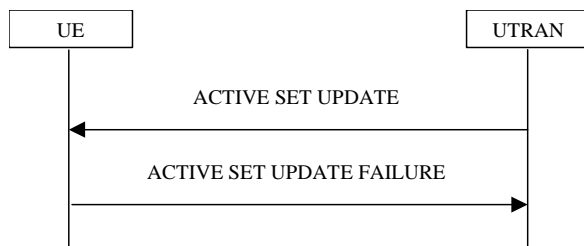

Figure 51: Active Set Update procedure, failure case

8.3.4.1 General

The purpose of the active set update procedure is to update the active set of the connection between the UE and UTRAN. This procedure shall be used in CELL_DCH state. The UE should keep on using the old RLS while configuring the new RLS. Also the UE should keep the transmitter turned on during the procedure. This procedure is only used in FDD mode.

8.3.4.2 Initiation

The procedure is initiated when UTRAN orders a UE in CELL_DCH state, to make the following modifications of the active set of the connection:

- a) Radio link addition;
- b) Radio link removal;
- c) Combined radio link addition and removal.

In case a) and c), UTRAN should:

- prepare new additional radio link(s) in the UTRAN prior to the command to the UE.

In all cases, UTRAN should:

- send an ACTIVE SET UPDATE message on downlink DCCH using AM or UM RLC.

UTRAN should include the following information:

- IE "Radio Link Addition Information": Downlink DPCH information and other optional parameters relevant for the ~~additional~~ radio links to be added along with the IE "Primary CPICH info" used for the reference ID to indicate which radio link to add. This IE is needed in cases a) and c) listed above;
- IE "Radio Link Removal Information": IE "Primary CPICH info" used for the reference ID to indicate which radio link to remove. This IE is needed in cases b) and c) listed above.

If SRNS relocation is performed simultaneously during active set update procedure when all radio links are replaced simultaneously, the UTRAN shall include the IE "U-RNTI" and IE "CN domain identity" and IE "NAS system information" in the ACTIVE SET UPDATE messages.

8.3.4.3 Reception of an ACTIVE SET UPDATE message by the UE

- Upon reception of an ACTIVE SET UPDATE message the UE shall ~~store~~ store the received IE "Radio Link Addition Information" and the IE "Radio Link Removal Information" to the variable ORDERED_ASU.

The UE shall act upon all received information elements as specified in 8.6, unless specified otherwise in the following. The UE shall:

- first add the RLS indicated in the IE "Radio Link Addition Information";
- remove the RLS indicated in the IE "Radio Link Removal Information". If the UE active set is full or becomes full, an RL, which is included in the IE "Radio Link Removal Information" for removal, shall be removed before adding RL, which is included in the IE "Radio Link Addition Information" for addition;
- if the ACTIVE SET UPDATE message includes the IE "U-RNTI":
 - update its identity;
- if the ACTIVE SET UPDATE message includes the IE "CN domain identity" and the IE "NAS system information":
 - forward the content of the IE to the non-access stratum entity of the UE indicated by the IE "CN domain identity";
- if the ACTIVE SET UPDATE message includes the IE 'TFCI combining indicator' associated with a radio link to be added:
 - configure Layer 1 to soft combine TFCI (field 2) of this new link with those links already in the TFCI (field 2) combining set;
- transmit an ACTIVE SET UPDATE COMPLETE message on the uplink DCCH using AM RLC without waiting for the Physical Layer synchronization;
- set the IE "RRC transaction identifier" in the ACTIVE SET UPDATE COMPLETE message to
 - the value of "RRC transaction identifier" in the entry for the ACTIVE SET UPDATE message in the table "Accepted transactions" in the variable TRANSACTIONS, and;
 - clear that entry.
- if the variable RB_UPLINK_CIPHERING_ACTIVATION_TIME_INFO is set:
 - include and set the IE "Radio bearer uplink ciphering activation time info" to the value of that variable;
- ~~when the successful delivery of the ACTIVE SET UPDATE COMPLETE message has been submitted to lower layers for transmission~~ confirmed by RLC:
 - clear the contents of the variable ORDERED_ASU;
 - clear the variable RB_UPLINK_CIPHERING_ACTIVATION_TIME_INFO and the procedure ends on the UE side.

8.3.4.4 ~~Abnormal case:~~ Unsupported configuration in the UE

If UTRAN instructs the UE to use a configuration that it does not support; ~~or if a radio link in the IE "Radio Link Removal Information" in the ACTIVE SET UPDATE message is not part of the active set,~~ the UE shall:

- keep the active set and the contents of the variable ORDERED_ASU, as it was before the ACTIVE SET UPDATE message was received;
- transmit an ACTIVE SET UPDATE FAILURE message on the DCCH using AM RLC;
- set the IE "RRC transaction identifier" in the ACTIVE SET UPDATE FAILURE message to
 - the value of "RRC transaction identifier" in the entry for the ACTIVE SET UPDATE message in the table "Accepted transactions" in the variable TRANSACTIONS, and;

- ~~clear that entry.~~
- set the IE "failure cause" to "configuration unacceptable";
- ~~when the successful delivery of the ACTIVE SET UPDATE FAILURE message has been confirmed by RLC submitted to lower layers for transmission the procedure ends on the UE side.~~

8.3.4.4a Invalid configuration

If any of the following conditions are valid:

- ~~a radio link indicated by the IE "Downlink DPCH info for each RL" in the IE "Radio link addition information" has a different spreading factor than the spreading factor for the radio links at the time indicated by the IE "Activation time", and/or;~~
- ~~a radio link in the IE "Radio Link Removal Information" in the ACTIVE SET UPDATE message is not part of the active set at the time indicated by the IE "Activation time", and/or~~
- ~~the variable INVALID_CONFIGURATION is set to TRUE;~~

the UE shall:

- ~~keep the active set and the contents of the variable ORDERED_ASU, as it was before the ACTIVE SET UPDATE message was received;~~
- ~~transmit an ACTIVE SET UPDATE FAILURE message on the DCCH using AM RLC;~~
- ~~set the IE "RRC transaction identifier" in the ACTIVE SET UPDATE FAILURE message to~~
 - ~~the value of "RRC transaction identifier" in the entry for the ACTIVE SET UPDATE message in the table "Accepted transactions" in the variable TRANSACTIONS, and;~~
 - ~~clear that entry.~~
- ~~set the IE "failure cause" to "Invalid configuration";~~
- ~~when the ACTIVE SET UPDATE FAILURE message has been delivered to lower layers for transmission the procedure ends on the UE side.~~

8.3.4.5 Reception of the ACTIVE SET UPDATE COMPLETE message by the UTRAN

When the UTRAN has received the ACTIVE SET UPDATE COMPLETE message,

- the UTRAN may remove radio link(s) that are indicated to remove to the UE in case b) and c); and
- the procedure ends on the UTRAN side.

8.3.4.6 Reception of the ACTIVE SET UPDATE FAILURE message by the UTRAN

When the UTRAN has received the ACTIVE SET UPDATE FAILURE message, the UTRAN may delete radio links that were included in the IE "Radio Link Addition Information" for addition. The procedure ends on the UTRAN side.

8.3.4.7 ~~Subsequently received ACTIVE SET UPDATE messages~~

If the variable ORDERED_CONFIG is set because of an ACTIVE SET UPDATE message previously received, the UE shall

- ~~ignore the subsequently received ACTIVE SET UPDATE message~~
- ~~keep the configuration as before the subsequent ACTIVE SET UPDATE message was received.~~

8.3.4.8 ~~Compatible simultaneous reconfiguration~~

If any of the variables ORDERED_CONFIG or ORDERED_ASU are set because of any message other than ACTIVE SET UPDATE, the UE shall:

- ~~— transmit an ACTIVE SET UPDATE FAILURE message on the DCCH using AM RLC;~~
- ~~— set the IE "failure cause" to "incompatible simultaneous reconfiguration";~~
- ~~— when the successful delivery of the ACTIVE SET UPDATE FAILURE message has been confirmed by RLC:~~
 - ~~— keep the active set and the contents of the variable ORDERED_ASU, as it was before the ACTIVE SET UPDATE message was received and the procedure ends.~~

8.3.4.9 Invalid ACTIVE SET UPDATE message

If none of the variables ORDERED_CONFIG or ORDERED_ASU are set and the ACTIVE SET UPDATE message contains a protocol error causing the variable PROTOCOL_ERROR_REJECT to be set to TRUE according to clause 16, the UE shall perform procedure specific error handling as follows:

- transmit a ACTIVE SET UPDATE FAILURE message on the uplink DCCH using AM RLC;
- set the IE "RRC transaction identifier" in the ACTIVE SET UPDATE FAILURE message to
 - the value of "RRC transaction identifier" in the entry for the ACTIVE SET UPDATE message in the table "Rejected transactions" in the variable TRANSACTIONS, and;
 - clear that entry.
- set the IE "failure cause" to the cause value "protocol error";
- include the IE "Protocol error information" with contents set to the value of the variable PROTOCOL_ERROR_INFORMATION;
- ~~when the successful delivery of the ACTIVE SET UPDATE FAILURE message has been confirmed by RLC delivered to lower layers for transmission:~~
 - resume normal operation as if the invalid ACTIVE SET UPDATE message has not been received and the procedure ends.

8.3.5 Hard handover

8.3.5.1 ~~Non-synchronised CFN discontinuous Timing re-initialized~~ hard handover

8.3.5.1.1 General

The purpose of the ~~CFN discontinuous timing re-initialized non-synchronised~~ hard handover procedure is to remove all the RL(s) in the active set and establish new RL(s) along with changing a change in the UL transmission timing and the CFN in the UE according to the SFN of the target cell. (see subclause 8.5.17-CFN calculation).

This procedure is initiated when UTRAN does not know the target SFN timing before hard handover.

8.3.5.1.2 Initiation

~~CFN discontinuous Timing re-initialized Non-synchronised~~ hard handover initiated by the network UTRAN is normally performed by using the procedure "Physical channel reconfiguration" (subclause 8.2.6), but may also be performed by using either one of the following the procedures:

- "radio bearer establishment" (subclause 8.2.1),
- "Radio bearer reconfiguration" (subclause 8.2.2),
- "Radio bearer release" (subclause 8.2.3) or

- ___ "Transport channel reconfiguration" (subclause 8.2.4).

If IE "Timing indication" has the value "initialise", UE shall ~~initiate~~ ~~execute~~ ~~CFN discontinuous~~ ~~the Timing Re-~~ ~~initialized non-synchronised hard handover~~ procedure by following the procedure indicated in the subclause relevant to the procedure chosen by the UTRAN.

8.3.5.2 ~~CFN continuous~~Timing-maintained Synchronised hard handover

8.3.5.2.1 General

The purpose of the ~~CFN continuous~~Timing Maintained synchronised hard handover procedure is to remove all the RL(s) in the active set and establish new RL(s) while maintaining the UL transmission timing and the CFN in the UE.

This procedure can be initiated only if UTRAN knows the target SFN timing before hard handover. The target SFN timing can be known by UTRAN in the following 2 cases:

- UE reads SFN when measuring "CFN-SFN observed time difference" and sends it to the UTRAN in MEASUREMENT REPORT message.
- UTRAN internally knows the time difference between the cells.

8.3.5.2.2 Initiation

~~CFN continuous~~Timing maintained Synchronised hard handover initiated by the network is normally performed by using the procedure "Physical channel reconfiguration" (subclause 8.2.6), but may also be performed by using either one of the following the-procedures:

- ___ ~~radio-Radio~~ bearer establishment" (subclause 8.2.1),
- ___ "Radio bearer reconfiguration" (subcaluse 8.2.2),
- ___ "Radio bearer release" (subcaluse 8.2.3) or
- ___ "Transport channel reconfiguration" (subclause 8.2.4).

If IE "Timing indication" has the value "maintain", UE shall initiate ~~CFN continuous~~the Timing Maintained synchronised hard handover procedure by following the procedure indicated in the subclause relevant to the procedure chosen by the UTRAN.

8.3.6 Inter-system handover to UTRAN

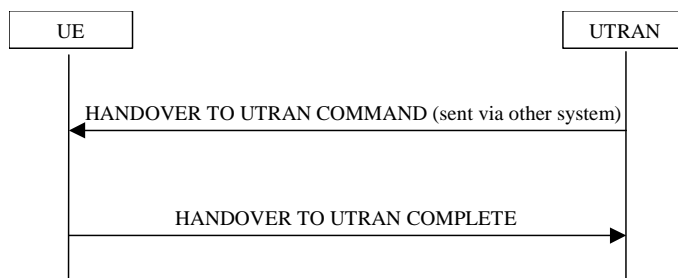

Figure 52: Inter system handover to UTRAN, successful case

8.3.6.1 General

The purpose of the inter system handover procedure is to, under the control of the network, transfer a connection between the UE and another radio access technology (e.g. GSM) to UTRAN.

8.3.6.2 Initiation

The procedure is initiated when a radio access technology other than UTRAN, e.g. GSM, using system specific procedures, orders the UE to make a handover to UTRAN.

A Handover to UTRAN command message is sent to the UE via the radio access technology from which inter-system handover is performed.

UTRAN should include the following information in the Handover to UTRAN command message.

- the IE "U-RNTI" to be assigned;
- the IE "Predefined radio configuration identity", to indicate which pre-defined configuration of RB, traffic channel and physical channel parameters shall be used;
- PhyCH information elements.

NOTE: During handover to UTRAN, UTRAN can only assign values of IEs "U-RNTI" and "scrambling code" that are within the special subranges defined exclusively for this procedure. UTRAN may re-assign other values after completion of the handover procedure.

8.3.6.3 Reception of Handover to UTRAN command message by the UE

The UE shall be able to receive a HANDOVER TO UTRAN COMMAND message and perform an inter-system handover, even if no prior UE measurements have been performed on the target UTRAN cell and/or frequency.

The UE shall act upon all received information elements as specified in 8.6, unless specified otherwise in the following. The UE shall:

- store the value of the IE "U-RNTI"; and[ERA2]
- initiate the signalling link, the RB(s) and traffic channel(s) in accordance with the predefined parameters identified by the IE "Predefined radio configuration identity";
- initiate the physical channels in accordance with the predefined parameters identified by the IE "Predefined radio configuration identity" and the received physical channel information elements;
- perform an open loop estimation to determine the UL transmission power, taking into account the received IE "Maximum allowed UL TX power" and move to CELL_DCH state;
- apply the same ciphering (ciphered/ unciphered, algorithm) as prior to inter system handover, unless a change of algorithm is requested by means of the "Ciphering algorithm".

If the UE succeeds in establishing the connection to UTRAN, it shall:

- transmit a HANDOVER TO UTRAN COMPLETE message on the uplink DCCH;
- when the successful delivery of the HANDOVER TO UTRAN COMPLETE message has been submitted to lower layers for transmission~~confirmed by RLC~~, the procedure ends.

8.3.6.4 Invalid Handover to UTRAN command message

If the UE receives a Handover to UTRAN command message, which contains a protocol error causing the variable PROTOCOL_ERROR_REJECT to be set to TRUE according to clause 16, the UE shall perform procedure specific error handling as follows:

- Resume the connection used before the handover to the source radio access technology;
- Indicate a failure to the source radio access technology, using "protocol error" as cause for the failure;
- If allowed by the source RAT~~If possible~~, transmit an RRC STATUS message to the other-source~~other~~ radio access technology, and include the IE "Protocol error information" with contents set to the value of the variable PROTOCOL_ERROR_INFORMATION;
- Other details may be specified-provided in the specifications related to the source radio access technology.

8.3.6.5 UE fails to perform handover

If the UE does not succeed ~~to~~in establishing the connection to UTRAN, it shall terminate the procedure including release of the associated resources, resume the connection used before the handover and indicate the failure to the other radio access technology.

Upon receiving an indication about the failure from the other radio access technology, UTRAN should release the associated resources and the context information concerning this UE.

8.3.6.6 Reception of message HANDOVER TO UTRAN COMPLETE by the UTRAN

Upon receiving a HANDOVER TO UTRAN COMPLETE message, UTRAN should consider the inter- system handover procedure as completed successfully and indicate this to the CN.

8.3.7 Inter-system handover from UTRAN

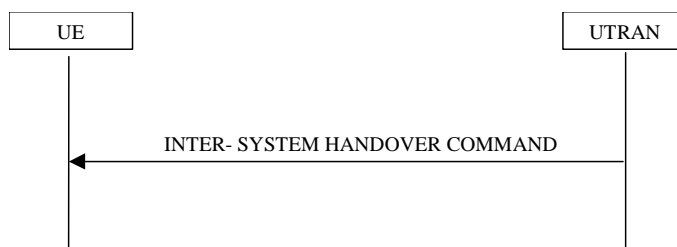

Figure 53: Inter system handover from UTRAN, successful case

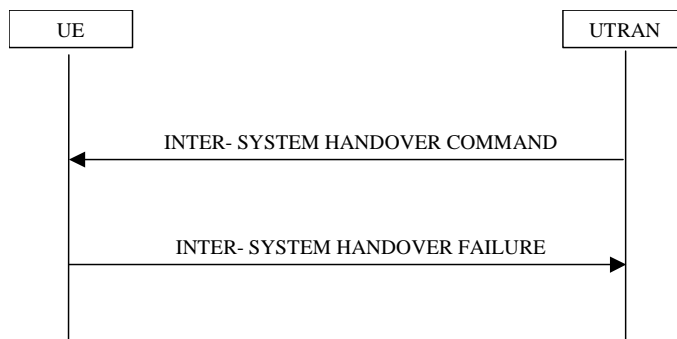

Figure 54: Inter system handover from UTRAN, failure case

8.3.7.1 General

The purpose of the inter system handover procedure is to, under the control of the network, transfer a connection between the UE and UTRAN to another radio access technology (e.g. GSM). This procedure may be used in CELL_DCH and CELL_FACH state.

8.3.7.2 Initiation

The procedure is initiated when UTRAN orders a UE in CELL_DCH or CELL_FACH state, to make a handover to a radio access technology other than UTRAN, e.g. GSM.

To initiate the procedure, UTRAN sends an INTER- SYSTEM HANDOVER COMMAND message.

8.3.7.3 Reception of an INTER- SYSTEM HANDOVER COMMAND message by the UE

The UE shall take the following actions:

- establish the connection to the other radio access technology, by using the contents of the IE "Inter system message". This IE contains a message specified in some other standard, as indicated by the IE "System type", and carries information about the candidate/ target cell identifier(s) and radio parameters relevant for the other radio access technology. The correspondence between the value of the IE "System type" and the standard to apply is the following:

Value of the IE "System type"	Standard to apply
GSM except PCS 1900 band	GSM 04.18, version 8.5.0 or later, as if the message was sent on any frequency except in the 1900 bandwidth
PCS 1900 band	GSM 04.18, version 8.5.0 or later, as if the message was sent was in the 1900 bandwidth
cdma2000	TIA/EIA/IS-2000 or later, TIA/EIA/IS-833 or later, TIA/EI/IS-834 or later

- for each IE "Remaining radio access bearer", associate the radio access bearer given by the IE "RAB info" to the radio resources in the target radio access technology given by the IE "Inter system message". Other information for making the association may be included in the IE "Inter system message" and requirements may be stated in the specifications relevant for the target system-~~[FFS]~~.
- switch the current connection to the other radio access technology.

NOTE 1: Requirements concerning the establishment of the radio connection towards the other radio access technology and the signalling procedure are outside the scope of this specification.

NOTE 2: The release of the UMTS radio resources is initiated by the other radio access technology.

NOTE 3: Currently only one radio access bearer can be associated with the IE "Inter-system message", and this association is limited to the radio access bearers in the CS domain. It is assumed that all the radio access bearers in the PS domain, if any, remain after the handover.

8.3.7.4 Successful completion of the inter-system handover

Upon successfully completing the handover, UTRAN should release the radio connection and remove all context information for the concerned UE.

8.3.7.5 UE fails to complete requested handover

If the UE does not succeed to establish the connection to the other radio access technology, it shall

- resume the connection to UTRAN using the resources used before receiving the INTER-SYSTEM HANDOVER COMMAND message; and
- set the IE "RRC transaction identifier" in the INTER-SYSTEM HANDOVER FAILURE message to
 - the value of "RRC transaction identifier" in the entry for the INTER-SYSTEM HANDOVER COMMAND message in the table "Accepted transactions" in the variable TRANSACTIONS, and;
 - clear that entry;
- transmit the INTER-SYSTEM HANDOVER FAILURE message on uplink DCCH using AM RLC. When the successful delivery of the INTER-SYSTEM FAILURE message has been confirmed by RLC submitted to lower layers for transmission, the procedure ends.

8.3.7.6 Invalid INTER-SYSTEM HANDOVER COMMAND message

If the INTER-SYSTEM HANDOVER COMMAND message contains a protocol error causing the variable PROTOCOL_ERROR_REJECT to be set to TRUE according to clause 16, the UE shall perform procedure specific error handling as follows:

- transmit a INTER-SYSTEM HANDOVER FAILURE message on the uplink DCCH using AM RLC;
- set the IE "RRC transaction identifier" in the INTER-SYSTEM HANDOVER FAILURE message to

- the value of "RRC transaction identifier" in the entry for the INTER-SYSTEM HANDOVER COMMAND message in the table "Rejected transactions" in the variable TRANSACTIONS, and;
- clear that entry;
- set the IE "failure cause" to the cause value "protocol error";
- include the IE "Protocol error information" with contents set to the value of the variable PROTOCOL_ERROR_INFORMATION;
- ~~when the successful delivery of the INTER-SYSTEM HANDOVER FAILURE message has been confirmed by RLC~~submitted to lower layers for transmission:
 - resume normal operation as if the invalid INTER-SYSTEM HANDOVER COMMAND message has not been received and the procedure ends.

8.3.7.7 Reception of an INTER-SYSTEM HANDOVER FAILURE message by UTRAN

Upon receiving an INTER-SYSTEM HANDOVER FAILURE message, UTRAN may release the resources in the other radio access technology.

8.3.8 Inter-system cell reselection to UTRAN

8.3.8.1 General

The purpose of the inter system cell reselection procedure to UTRAN is to, under the control of the UE and to some extent the other radio access technology, transfer a connection between the UE and another radio access technology (e.g. GSM/GPRS) to UTRAN.

8.3.8.2 Initiation

When the UE makes an inter-system cell reselection to UTRAN according to the criteria specified in TS 25.304, it shall initiate this procedure. The inter-system cell reselection made by the UE may use system information broadcast from the other radio access technology or UE dedicated information.

The UE shall initiate an RRC connection establishment procedure as specified in subclause 8.1.3 except that the IE "establishment cause" in the RRC CONNECTION REQUEST message shall be set to "Inter-system cell reselection". After initiating an RRC connection establishment, the UE shall release all resources specific to the other radio access technology.

8.3.8.3 UE fails to complete an inter-system cell reselection

If the inter-system cell reselection fails before the UE has initiated the RRC connection establishment the UE may return back to the other radio access technology.

If the RRC connection establishment fails the UE shall enter idle mode.

8.3.9 Inter-system cell reselection from UTRAN

8.3.9.1 General

The purpose of the inter system cell reselection procedure from UTRAN is to, under the control of the UE and to some extent the network, transfer a connection between the UE and UTRAN to another radio access technology (e.g. GSM/GPRS).

8.3.9.2 Initiation

This procedure ~~may be initiated~~is applicable in states CELL_FACH, CELL_PCH or URA_PCH.

When the UE based on received system information makes a cell reselection to a radio access technology other than UTRAN, e.g. GSM/GPRS, according to the criteria specified in [TS3GPP TS 25.304](#), the UE shall.

- start timer T309;
- initiate the establishment of a connection to the other radio access technology according to its specifications.

8.3.9.3 Successful cell reselection

When the UE has succeeded in reselecting a cell in the other radio access technology and has initiated an establishment of a connection, it shall stop timer T309 and release all UTRAN specific resources.

UTRAN should release all UE dedicated resources upon indication that the UE has completed a connection establishment to the other radio access technology.

8.3.9.4 Expiry of timer T309

If the timer T309 expires before the UE succeeds to initiate an establishment of a connection to the other radio access technology, the UE shall resume the connection to UTRAN using the resources used before initiating the inter system cell reselection procedure.

8.4 Measurement procedures

The UE measurements are grouped into 6 different categories, according to what the UE should measure.

The different types of measurements are:

- Intra-frequency measurements: measurements on downlink physical channels at the same frequency as the active set. Detailed description is found in subclause 14.1.
- Inter-frequency measurements: measurements on downlink physical channels at frequencies that differ from the frequency of the active set. Detailed description is found in subclause 14.2.
- Inter-system measurements: measurements on downlink physical channels belonging to another radio access technology than UTRAN, e.g. PDC or GSM. Detailed description is found in subclause 14.3.
- Traffic volume measurements: measurements on uplink traffic volume. Detailed description is found in subclause 14.4.
- Quality measurements: Measurements of quality parameters, e.g. downlink transport block error rate.
- Internal measurements: Measurements of UE transmission power and UE received signal level. Detailed description is found in subclause 14.5.

The same type of measurements may be used as input to different functions in UTRAN. The UE shall support a number of measurements running in parallel. The UE shall also support that each measurement is controlled and reported independently of every other measurement.

Cells that the UE is monitoring (e.g. for handover measurements) are grouped in the UE into three different categories:

1. Cells, which belong to the active set. User information is sent from all these cells and they are simultaneously demodulated and coherently combined. In FDD, these cells are involved in soft handover. In TDD the active set always comprises of one cell only.
2. Cells, which are not included in the active set, but are monitored according to a neighbour list assigned by the UTRAN belong to the monitored set.
3. Cells, which are not included in the active set, and are detected by the UE without receiving a neighbour list from the UTRAN belong to the detected set. Intra-frequency measurements of the unlisted set is required only of UEs in CELL_DCH state.

NOTE: The cells of the monitored set are not excluded from the detected set.

UTRAN may start a measurement in the UE by transmitting a MEASUREMENT CONTROL message. This message includes the following measurement control information:

1. Measurement type: One of the types listed above describing what the UE shall measure.
2. Measurement identity number: A reference number that should be used by the UTRAN when modifying or releasing the measurement and by the UE in the measurement report.
3. Measurement command: One out of three different measurement commands.
 - Setup: Setup a new measurement.
 - Modify: Modify a previously defined measurement, e.g. to change the reporting criteria.
 - Release: Stop a measurement and clear all information in the UE that are related to that measurement.
4. Measurement objects: The objects the UE shall measure on, and corresponding object information.
5. Measurement quantity: The quantity the UE shall measure. This also includes the filtering of the measurements.
6. Reporting quantities: The quantities the UE shall include in the report in addition to the quantities that are mandatory to report for the specific event.
7. Measurement reporting criteria: The triggering of the measurement report, e.g. periodical or event-triggered reporting. The events are described for each measurement type in clause 14.
8. Reporting mode: This specifies whether the UE shall transmit the measurement report using AM or UM RLC.

All these measurement parameters depend on the measurement type and are described in more detail in clause 14.

When the reporting criteria are fulfilled, i.e. a specified event occurred or the time since last report indicated for periodical reporting has elapsed, the UE shall send a MEASUREMENT REPORT message to UTRAN.

In idle mode, the UE shall perform measurements according to the measurement control information included in System Information Block Type 11, which is transmitted on the BCCH.

In CELL_FACH, CELL_PCH or URA_PCH state, the UE shall perform measurements according to the measurement control information included in System Information Block Type 12, which is transmitted on the BCCH. If the UE has not received System Information Block Type 12, it shall perform measurements according to the measurement control information included in System Information Block Type 11, which is transmitted on the BCCH.

In CELL_DCH state, the UE shall report radio link related measurements to the UTRAN with a MEASUREMENT REPORT message. The UE may also be requested by the UTRAN to report unlisted cells, which it has detected. The triggering event for the UE to send a MEASUREMENT REPORT message is that a detected cell exceeds an absolute threshold.

In order to receive information for the establishment of immediate macrodiversity (FDD) or to support the DCA algorithm (TDD), the UTRAN may also request the UE to append radio link related measurement reports to the following messages sent on the RACH:

- RRC CONNECTION REQUEST message sent to establish an RRC connection;
- RRC CONNECTION RE-ESTABLISHMENT REQUEST message sent to re-establish an RRC connection;
- INITIAL DIRECT TRANSFER message sent uplink to establish a signalling connection;
- CELL UPDATE message sent to respond to a UTRAN originated page;
- MEASUREMENT REPORT message sent to report uplink traffic volume;
- CAPACITY REQUEST message sent to request PUSCH capacity (TDD only).

NOTE: Whether or not measured results can be appended to other messages and in other scenarios is FFS.

8.4.1 Measurement control



Figure 55: Measurement Control, normal case

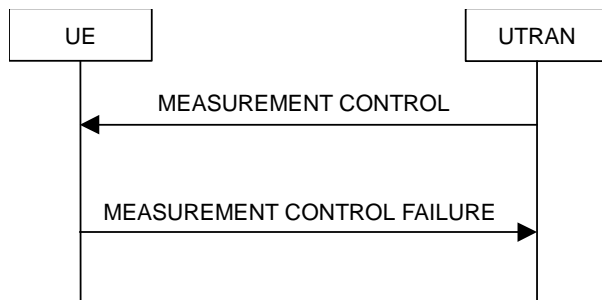

Figure 56: Measurement Control, UE reverts to old measurements

8.4.1.1 General

The purpose of the measurement control procedure is to Setup, modify or release a measurement in the UE.

8.4.1.2 Initiation

The UTRAN may request a measurement by the UE to be setup, modified or released with a MEASUREMENT CONTROL message, which is transmitted on the downlink DCCH using AM RLC.

When a new measurement is setup, UTRAN should set the IE "Measurement identity number" to a value, which is not used for other measurements. UTRAN may use several "Measurement identity number" within a same "Measurement type". In case of setting several "Measurement identity numbers" within a same "Measurement type", "Measurement object" can be set differently for each measurement with different "Measurement identity numbers". If no "Measurement object" is indicated for additional measurement within a same "Measurement type" in case of "Measurement type" = "Intra-frequency", it implies that only active set cells are the "Measurement objects".

When a current measurement is modified or released, UTRAN should set the IE "Measurement identity number" to a value, which is used for the current measurement. In case of modifying IEs within a "Measurement identity number", it is not needed for UTRAN to indicate the IEs other than modifying IEs, and the UE continuously uses the current values of the IEs which are not modified.

UTRAN should take the UE capabilities into account when a measurement is assigned to the UE.

8.4.1.3 Reception of MEASUREMENT CONTROL by the UE

Upon reception of a MEASUREMENT CONTROL message the UE shall perform actions specified in 8.6 unless otherwise specified below.

The UE shall:

- read the IE "Measurement command";
- if the IE "measurement command" has the value "setup":
 - store this measurement in the variable MEASUREMENT_IDENTITY according to the IE "measurement identity number";

- store into the variable MEASUREMENT_IDENTITY the control information defined by IE "Measurement object", the IE "Measurement quantity", the IE "Reporting quantity", the IE "Measurement reporting criteria", the IE "Measurement validity", the IE "Reporting mode" and if present all IEs "Additional measurement identity number", which are valid for this measurement type; and
- for measurement types "inter-system measurement" or "inter-frequency measurement":
- begin measurements according to the stored control information for this measurement identity number optionally with the use of compressed mode if at least one compressed mode pattern sequence is simultaneously activated with inclusion of the IE "DPCH compressed mode status info"; or
- for any other measurement type:
- begin measurements according to the stored control information for this measurement identity number.
- if the IE "Measurement command" has the value "modify":
 - retrieve the stored measurement information associated with the identity indicated in the IE "measurement identity number";
 - if any of the IEs "measurement object", IE "measurement quantity", IE "reporting quantity", IE "measurement reporting criteria", IE "measurement validity", IE "reporting mode" or IE "Additional measurement identity number" are present in the MEASUREMENT CONTROL message, the control information defined by that IE shall replace the corresponding stored information;
 - store the new set of IEs and associate them with the measurement identity number;
 - resume the measurements according to the new stored measurement control information.
 - if the IE "measurement command has the value "release":
 - terminate the measurement associated with the identity given in the IE "measurement identity number";
 - clear all stored measurement control information related associated to this measurement identity number.
 - if the IE "DPCH Compressed Mode Status Info" is present, the UE shall:
 - activate the pattern sequence stored in variable TGPS_IDENTITY corresponding to each IE "TGPSI" for which the "TGPS status flag" is set to "activate" and begin the inter-frequency and/or inter-system measurements corresponding to the pattern sequence measurement purpose of each activated pattern sequence;
 - deactivate the pattern sequence stored in variable TGPS_IDENTITY corresponding to each IE "TGPSI" for which the "TGPS status flag" is set to "deactivate" and terminate the inter-frequency and/or inter-system measurements corresponding to the pattern sequence measurement purpose of each deactivated pattern sequence;

After the above actions have been performed, the procedure ends.

8.4.1.4 Unsupported measurement in the UE

If UTRAN instructs the UE to perform a measurement that is not supported by the UE, the UE shall:

- retain the measurement configuration that was valid before the MEASUREMENT CONTROL message was received;
- transmit a MEASUREMENT CONTROL FAILURE message on the DCCH using AM RLC.
- set the IE "RRC transaction identifier" in the MEASUREMENT CONTROL FAILURE message to
 - the value of "RRC transaction identifier" in the entry for the MEASUREMENT CONTROL message in the table "Accepted transactions" in the variable TRANSACTIONS, and;
 - clear that entry;
- The UE shall set the cause value in IE "failure cause" to "unsupported measurement";

- when the MEASUREMENT CONTROL FAILURE message has been delivered to lower layers for transmission:
- resume normal operation as if the invalid MEASUREMENT CONTROL message has not been received and the procedure ends.

8.4.1.5 Invalid MEASUREMENT CONTROL message

If the MEASUREMENT CONTROL message contains a protocol error causing the variable PROTOCOL_ERROR_REJECT to be set to TRUE according to clause 16, the UE shall perform procedure specific error handling as follows:

- transmit a MEASUREMENT CONTROL FAILURE message on the uplink DCCH using AM RLC;
- set the IE "RRC transaction identifier" in the MEASUREMENT CONTROL FAILURE message to
 - the value of "RRC transaction identifier" in the entry for the MEASUREMENT CONTROL message in the table "Rejected transactions" in the variable TRANSACTIONS, and;
 - clear that entry;
- set the IE "failure cause" to the cause value "protocol error";
- include the IE "Protocol error information" with contents set to the value of the variable PROTOCOL_ERROR_INFORMATION;
- when the successful delivery of the MEASUREMENT CONTROL FAILURE message has been submitted to lower layers for transmission confirmed by RLC:
 - resume normal operation as if the invalid MEASUREMENT CONTROL message has not been received and the procedure ends.

8.4.1.6 Reception of the MEASUREMENT CONTROL FAILURE message by the UTRAN

When the UTRAN receives a MEASUREMENT CONTROL FAILURE message the procedure ends.

8.4.1.7 Measurements after transition from CELL_DCH to CELL_FACH state

The UE shall obey the follow rules for different measurement types after transiting from CELL_DCH to CELL_FACH state:

Intra-frequency measurement

The UE shall stop intra-frequency type measurement reporting assigned in a MEASUREMENT CONTROL message.

After transition to CELL_FACH state, the UE shall begin monitoring neighbouring cells listed in the "intra-frequency cell info" received in "System Information Block 12" (or "System Information Block 11").

If the UE has no previously assigned, valid intra-frequency measurement for CELL_DCH state, the UE shall store "intra-frequency measurement reporting criteria", from "System Information Block 12" (or "System Information Block 11"), for use after a subsequent transition to CELL_DCH state.

If the UE receives the "Intra-frequency reporting quantity for RACH Reporting" and "Maximum number of Reported cells on RACH" IEs from "System Information Block 12" (or "System Information Block 11"), the UE use this information for reporting measured results in RACH messages.

Inter-frequency measurement

The UE shall stop the inter-frequency type measurement reporting assigned in a MEASUREMENT CONTROL message.

After transition to CELL_FACH state, the UE shall begin monitoring neighbouring cells listed in the "inter-frequency cell info" received in "System Information Block 12" (or "System Information Block 11").

The UE shall not measure on other frequencies except at the measurement occasions given in 8.5.12.

Inter-system measurement

The UE shall stop the inter-system type measurement reporting assigned in a MEASUREMENT CONTROL message.

After transition to CELL_FACH state, the UE shall begin monitoring neighbouring cells listed in the "inter-system" cell info" received in "System Information Block 12" (or "System Information Block 11").

The UE shall not measure on other systems except at the measurement occasions given in 8.5.12.

Quality measurement

The UE shall stop the quality type measurement reporting assigned in a MEASUREMENT CONTROL message after transition from CELL_DCH to CELL_FACH state.

UE internal measurement

The UE shall stop the UE internal measurement reporting type of measurement assigned in a MEASUREMENT CONTROL message.

Traffic volume measurement

The UE shall stop or continue traffic volume type measurement reporting assigned in a MEASUREMENT CONTROL message according to the following rules:

- if the IE "measurement validity" for this measurement has been assigned to value "release":
 - delete the measurement associated with the variable MEASUREMENT IDENTITY.
- if the IE "measurement validity" for the measurement has been assigned to value "resume", and the IE "UE state for reporting" has been assigned to value "CELL_DCH":
 - stop measurement reporting;
 - save the measurement associated with the variable MEASUREMENT IDENTITY to be used after the next transition to CELL_DCH state.
- if the IE "measurement validity" for the measurement has been assigned to value "resume", and the IE "UE state for reporting" has been assigned to value "all states":
 - continue measurement reporting.
- if the UE has previously stored a measurement, for which the IE "measurement validity" has been assigned to value "resume" and for which the IE "UE state for reporting" has been assigned to value "all states except CELL_DCH":
 - resume this measurement and associated reporting.

If no traffic volume type measurement has been assigned to the UE with a MEASUREMENT CONTROL message when transiting to CELL_FACH state, the UE shall begin a traffic volume type measurement according to traffic volume measurement type information received in "System Information Block 12" (or "System Information Block 11").

8.4.1.8 Measurements after transition from CELL_FACH to CELL_DCH state

The UE shall obey the follow rules for different measurement types after transiting from CELL_FACH to CELL_DCH state:

Intra-frequency measurement

If the UE has previously in CELL_DCH state stored an intra-frequency measurement, for which the IE "measurement validity" has been assigned to value "resume" and for which the IE "UE state for reporting" has been assigned to value "CELL_DCH", the UE shall resume this measurement and associated reporting. If the UE has performed cell reselection whilst out of CELL_DCH state, the UE shall not resume the measurement.

If the UE has no previously assigned measurement, it shall continue monitoring the list of neighbouring cells assigned in the "intra-frequency cell info" IE in "System Information Block 12" (or "System Information Block 11"). If the "intra-frequency measurement reporting criteria" IE was included in "System Information Block 12" (or "System Information Block 11"), the UE shall send the MEASUREMENT REPORT message when reporting criteria are fulfilled. When the UE receives a MEASUREMENT CONTROL message including an intra-frequency measurement type assignment, the UE shall stop monitoring and measurement reporting for the list of neighbouring cells assigned in the "intra-frequency cell info" IE in "System Information Block 12" (or "System Information Block 11"). It shall also delete the measurement reporting criteria received in "System Information Block 12" (or "System Information Block 11").

Inter-frequency measurement

The UE shall stop monitoring the list of neighbouring cells assigned in the "inter-frequency cell info" IE in "System Information Block 12" (or "System Information Block 11"). If the UE has previously stored an inter-frequency measurement, for which the IE "measurement validity" has been assigned to value "resume" and for which the IE "UE state for reporting" has been assigned to value "CELL_DCH", the UE shall resume this measurement and associated reporting.

Inter-system measurement

The UE shall stop monitoring the list of neighbouring cells assigned in the "inter-frequency system info" IE in "System Information Block 12" (or "System Information Block 11"). If the UE has previously stored an inter-system measurement, for which the IE "measurement validity" has been assigned to value "resume" and for which the IE "UE state for reporting" has been assigned to value "CELL_DCH", the UE shall resume this measurement and associated reporting.

Traffic volume measurement

The UE shall stop or continue traffic volume type measurement reporting assigned in a MEASUREMENT CONTROL message sent on the FACH according to the following rules:

- If the IE "measurement validity" for this measurement has been assigned to value "release", the UE shall delete the measurement associated with the variable MEASUREMENT IDENTITY.
- If the IE "measurement validity" for the measurement has been assigned to value "resume", and the IE "UE state for reporting" has been assigned to value "CELL_FACH", the UE shall stop measurement reporting and save the measurement associated with the variable MEASUREMENT IDENTITY to be used after the next transition to CELL_FACH state.
- If the IE "measurement validity" for the measurement has been assigned to value "resume", and the IE "UE state for reporting" has been assigned to value "all states", the UE shall continue measurement reporting.

If the UE has previously stored a measurement, for which the IE "measurement validity" has been assigned to value "resume" and for which the IE "UE state for reporting" has been assigned to value "CELL_DCH", the UE shall resume this measurement and associated reporting.

If no traffic volume type measurement has been assigned to the UE with a MEASUREMENT CONTROL message when transiting to CELL_DCH state, the UE shall continue an ongoing traffic volume type measurement, which was assigned in "System Information Block 12" (or "System Information Block 11")

Traffic volume type measurement control parameters assigned in a MEASUREMENT CONTROL message shall always supersede parameters conveyed in "System Information Block 12" (or "System Information Block 11"). If the UE receives a MEASUREMENT CONTROL message including an traffic volume measurement type assignment, the UE shall delete the traffic volume measurement control information received in "System Information Block 12" (or "System Information Block 11").

8.4.1.9 Measurements after transition from idle mode to CELL_DCH state

The UE shall obey the follow rules for different measurement types after transiting from idle mode to CELL_DCH state:

Intra-frequency measurement

The UE shall continue monitoring the list of neighbouring cells assigned in the "intra-frequency cell info" IE in "System Information Block 12" (or "System Information Block 11"). If the "intra-frequency measurement reporting criteria" IE was included in "System Information Block 12" (or "System Information Block 11"), the UE shall send the MEASUREMENT REPORT message when reporting criteria are fulfilled.

When the UE receives a MEASUREMENT CONTROL message including an intra-frequency measurement type assignment, the UE shall stop monitoring and measurement reporting for the list of neighbouring cells assigned in the "intra-frequency cell info" IE in "System Information Block 12" (or "System Information Block 11"). It shall also delete the measurement reporting criteria received in "System Information Block 12" (or "System Information Block 11").

Inter-frequency measurement

The UE shall stop monitoring the list of neighbouring cells assigned in the "inter-frequency cell info" IE in "System Information Block 12" (or "System Information Block 11").

Inter-system measurement

The UE shall stop monitoring the list of neighbouring cells assigned in the "inter-frequency system info" IE in "System Information Block 12" (or "System Information Block 11").

Traffic volume measurement

The UE shall begin a traffic volume type measurement, which was assigned in "System Information Block 12" (or "System Information Block 11").

8.4.1.10 Measurements after transition from idle mode to CELL_FACH state

The UE shall obey the follow rules for different measurement types after transiting from idle mode to CELL_FACH state:

Intra-frequency measurement

The UE shall begin monitoring neighbouring cells listed in the "intra-frequency cell info" received in "System Information Block 12" (or "System Information Block 11").

If the UE receives "intra-frequency measurement reporting criteria", from "System Information Block 12" (or "System Information Block 11"), the UE shall store this information to use after a subsequent transition to CELL_DCH state.

If the UE receives the "Intra-frequency reporting quantity for RACH Reporting" and "Maximum number of Reported cells on RACH" IEs from "System Information Block 12" (or "System Information Block 11"), the UE use this information for reporting measured results in RACH messages.

Inter-frequency measurement

The UE shall begin monitoring neighbouring cells listed in the "inter-frequency cell info" received in "System Information Block 12" (or "System Information Block 11").

The UE shall not measure on other frequencies except at the measurement occasions given in 8.5.12.

Inter-system measurement

The UE shall begin monitoring neighbouring cells listed in the "inter-system" cell info" received in "System Information Block 12" (or "System Information Block 11").

The UE shall not measure on other systems except at the measurement occasions given in 8.5.12.

Traffic volume measurement

The UE shall begin a traffic volume type measurement according to traffic volume measurement type information received in "System Information Block 12" (or "System Information Block 11").

8.4.1.11 Measurements when measurement object is no longer valid

Traffic volume measurement

If UE is no longer using the transport channel that is specified in "traffic volume measurement object", UE shall ignore any measurements that are assigned to that transport channel. If none of the transport channels that are specified in "traffic volume measurement object" is being used, UE shall release that particular measurement and its measurement ID.

8.4.2 Measurement report



Figure 57: Measurement report, normal case

8.4.2.1 General

The purpose of the measurement reporting procedure is to transfer measurement results from the UE to UTRAN.

8.4.2.2 Initiation

In CELL_DCH state, the UE shall transmit a MEASUREMENT REPORT message on the uplink DCCH when the reporting criteria stored in variable MEASUREMENT_IDENTITY are fulfilled for any ongoing measurements that are being performed in the UE.

In CELL_FACH state, the UE shall transmit a MEASUREMENT REPORT message on the uplink DCCH when the reporting criteria stored in variable MEASUREMENT_IDENTITY are fulfilled for an ongoing traffic volume measurement which is being performed in the UE.

If the Radio Bearer associated with the MEASUREMENT_IDENTITY fulfilling the reporting criteria for an ongoing traffic volume measurement is mapped on transport channel of type USCH, the UE shall initiate the "PUSCH CAPACITY REQUEST" procedure instead of transmitting a MEASUREMENT REPORT (TDD Only).

In CELL_PCH or URA_PCH state, the UE shall first perform the cell update procedure in order to transit to CELL_FACH state and then transmit a MEASUREMENT REPORT message on the uplink DCCH when the reporting criteria stored in variable MEASUREMENT_IDENTITY are fulfilled for an ongoing traffic volume measurement which is being performed in the UE.

The reporting criteria are fulfilled if either:

- the time indicated in the stored IE "Periodical reporting" has elapsed for a given measurement that was either initiated or since the last measurement report related to this measurement was transmitted; or
- an event in stored IE "Measurement reporting criteria" was triggered. Events and triggering of reports for different measurement types are described in detail in clause 14.

The UE shall transmit the MEASUREMENT REPORT message using either AM or UM RLC according to the stored IE "measurement reporting mode" associated with the measurement identity number that triggered the report.

For the measurement, which triggered the MEASUREMENT REPORT message, the UE shall:

- Set the IE "measurement identity number" to the measurement identity number which is associated with that measurement in variable MEASUREMENT_IDENTITY.
- Set the IE "measured results" to include measurements according to the IE "reporting quantity" of that measurement stored in variable MEASUREMENT_IDENTITY.
- Set the IE "Measured results" in the IE "Additional measured results" according to the IE "reporting quantity" for all measurements associated with the measurement identities included in the IE "additional measurements" stored in variable MEASUREMENT_IDENTITY of the measurement that triggered the measurement report. If

several additional measured results are to be included, the UE shall sort them in ascending order according to their IE "measurement identity number" in the MEASUREMENT REPORT message.

If the MEASUREMENT REPORT message was triggered by an event (i.e. not a periodical report), the UE shall:

- Set the measurement event results according to the event that triggered the report.

8.4.2.3 Reception of a MEASUREMENT REPORT message by the UTRAN

When the UTRAN receives the MEASUREMENT REPORT message, the measurement reporting procedure ends.

8.5 General procedures

8.5.1 Selection of initial UE identity

The purpose of the IE "Initial UE identity" is to provide a unique UE identification at the establishment of an RRC connection. The type of identity shall be selected by the UE according to the following.

Upper layers shall set the variable SELECTED_PLMN. If the variable SELECTED_PLMN in the UE ~~has the value~~indicates "GSM-MAP", the UE shall choose "UE id type" in the IE "Initial UE identity" with the following priority:

1. TMSI (GSM-MAP): The TMSI (GSM-MAP) shall be chosen if available. The IE "LAI" in the IE "Initial UE identity" shall also be present when TMSI (GSM-MAP) is used, for making it unique.
2. P-TMSI (GSM-MAP): The P-TMSI (GSM-MAP) shall be chosen if available and no TMSI (GSM-MAP) is available. The IE "RAI" in the IE "Initial UE identity" shall in this case also be present when P-TMSI (GSM-MAP) is used, for making it unique.
3. IMSI (GSM-MAP): The IMSI (GSM-MAP) shall be chosen if available and no TMSI (GSM-MAP) or P-TMSI is available.
4. IMEI: The IMEI shall be chosen when none of the above three conditions are fulfilled.

When being used, the IEs "TMSI (GSM-MAP)", "P-TMSI (GSM-MAP)", "IMSI (GSM-MAP)", "LAI" and "RAI" shall be set equal to the values of the corresponding identities stored in the USIM or SIM.

If the variable SELECTED_PLMN in the UE ~~has the value~~indicates "ANSI-41", the UE shall choose "UE id type" in the IE "Initial UE identity" according to the procedure specified in the 3GPP2 document "3GPP2 C.P0004-A".

8.5.2 Actions when entering idle mode from connected mode

When entering idle mode from connected mode, the UE shall attempt to select a suitable cell to camp on. The UE shall perform cell selection when leaving connected mode according to 3GPP TS 25.304.

While camping on a cell, the UE shall acquire system information according to the system information procedure in subclause 8.1, perform measurements according to the measurement control procedure specified in subclause 8.4 and, if registered, be prepared to receive paging messages according to the paging procedure in subclause 8.2.

If IE "PLMN identity" within variable SELECTED_PLMN has the value "GSM-MAP", the UE shall delete any NAS system information received in connected mode, acquire the NAS system information in system information block type 1, and proceed according to 8.6.1.2.

When entering idle mode the current START value for every CN domain is stored in the USIM.

8.5.3 Open loop power control upon establishment of DPCCH

This procedure is used in FDD mode only.

When establishing the first DPCCH the UE shall start the UL inner loop power control at a power level according to:

- $DPCCH_Initial_power = DPCCH_Power_offset - CPICH_RSCP$

Where

DPCCH_Power_offset shall have the value of IE "DPCCH Power offset" in IE "Uplink DPCH power control info"

The value for the CPICH_RSCP shall be measured by the UE.

8.5.4 Physical channel establishment criteria

When a physical dedicated channel establishment is initiated by the UE, the UE shall start a timer T312 and wait for layer 1 to indicate N312 successive "in sync" indications. On receiving N312 successive "in sync" indications, the physical channel is considered established and the timer T312 is stopped and reset.

If the timer T312 expires before the physical channel is established, the UE shall consider this as a "physical channel establishment failure".

8.5.5 Actions in "out of service area" and "in service area"

This subclause specifies the general actions the UE shall perform when detects "out of service" or "in service" area. The UE behavior when it detects "out of service" or "in service" area and periodical cell update or periodical URA update has been configured is specified in subclause 8.3.1.

8.5.5.1 Detection of out of service area

When a suitable cell is not found based on the description in subclause 5.2.2.1 of TS 25.304, the UE considers it as an "out of service area".

8.5.5.2 Detection of in service area

When a suitable cell is found based on the description in 3GPP TS 25.304, the UE considers it as having detected "in service area".

8.5.5.3 Detection of out of service area in URA_PCH or CELL_PCH state

If the UE detects the "out of service area" and the UE is in URA_PCH or CELL_PCH state it shall perform the following actions:

- start timer T316
- perform processes described in subclause 7.2.2.;

8.5.5.4 Re-entering in service area in URA_PCH or CELL_PCH state

If the UE re-enters "in service area" before T316 expiry the UE shall perform the following actions:

- stop T316;
- perform processes described in subclause 7.2.2.;

8.5.5.5 T316 expiry

On T316 expiry the UE shall perform the following actions:

- start timer T317;
- initiate the cell update procedure using as cause "Re-entering service area" as specified in subclause 8.3.1.;

8.5.5.9 Detection of out of service area in CELL_FACH state

If the UE detects the "out of service area" and the UE is in CELL_FACH state it shall perform the following actions:

- start timer T317 if not already running;
- perform processes described in subclause 7.2.2.;

8.5.5.10 Re-entering in service area in CELL_FACH state

If the UE detects "in service area" before T317 expiry the UE shall perform the following actions:

- stop T317;
- initiate the cell update procedure using as cause "Re-entering service area" as specified in subclause 8.3.1.;
- perform processes described in subclause 7.2.2.;

8.5.5.11 T317 expiry

When the T317 expires, the UE shall:

- move to idle mode;
- release all dedicated resources;
- indicate an RRC connection failure to the non-access stratum.
- perform actions specified in subclause 8.5.2 when entering idle mode from connected mode.

8.5.6 Radio link failure criteria

In CELL_DCH State the UE shall start timer T313 after receiving N313 consecutive "out of sync" indications for the established DPCH physical channel from layer 1. The UE shall stop and reset timer T313 upon receiving successive N315 "in sync" indications from layer 1 and upon change of UE state. If T313 expires, the UE shall consider it as a "Radio link failure".

8.5.7 Generic state transition rules depending on received information elements

The state the UE shall move to depends on the presence of a number of IEs as follows:

~~IF IE "Uplink DPCH info" OR IE "Downlink DPCH info" is included THEN~~

~~The UE shall move to CELL_DCH state~~

~~ELSE IF "DRX indicatorRRC State Indicator" is set to "DRX with Cell updating" THEN~~

~~The UE shall move to CELL_PCH state~~

~~ELSE IF "DRX indicatorRRC State Indicator" is set to "DRX with URA updating" THEN~~

~~The UE shall move to URA_PCH state~~

~~ELSE IF "DRX indicatorRRC State Indicator" is set to "noDRX" OR "DRX indicatorRRC State Indicator" does not exist in message THEN~~

~~The UE shall move to CELL_FACH state~~

~~END~~

The IE "RRC State Indicator" indicates the state the UE shall enter. If the IE "RRC State Indicator" in the received message has the value:

- "CELL_FACH" the UE shall enter CELL_FACH state as dictated by the procedure governing the message received.

- "CELL_DCH" " the UE shall enter CELL_DCH state as dictated by the procedure governing the message received.
- "CELL_PCH" " the UE shall enter CELL_PCH state as dictated by the procedure governing the message received.
- "URA_PCH" " the UE shall enter URA_PCH state as dictated by the procedure governing the message received.

8.5.8 Open loop power control

For FDD and prior to PRACH or PCPCH transmission the UE shall calculate the power for the first preamble as:

$$\text{Preamble_Initial_Power} = \text{Primary CPICH DL TX power} - \text{CPICH_RSCP} + \text{UL interference} + \text{Constant Value}$$

Where

Primary CPICH DL TX power shall have the value of IE "Primary CPICH DL TX power",

UL interference shall have the value of IE "UL interference"; and

Constant Value shall have the value of IE "Constant Value".

The IEs "Primary CPICH DL TX power", "UL interference" and "Constant value" shall be read on system information in system information block 6 (or system information block type 5, if system information block type 6 is not being broadcast) and system information block 7.

The value for the CPICH_RSCP shall be measured by the UE.

As long as the physical layer is configured for PRACH or PCPCH transmission, the UE shall continuously recalculate the Preamble_Initial_Power when any of the broadcast parameters used in the above formula changes. The new Preamble_Initial_Power shall then be resubmitted to the physical layer.

For TDD the UE shall calculate the UL transmit power according to the following formulas for the PRACH, DPCH and USCH continuously while the physical channel is active:

- $\text{PPRACH} = \text{LPCCPCH} + \text{IBTS} + \text{RACH Constant value}$

NOTE: For the case where RACH Spreading Factor = 8, 3dB is added to RACH Constant Value

And for uplink dedicated physical channels:

- $\text{PDPCH} = \alpha \text{LPCCPCH} + (1-\alpha) \text{L0} + \text{IBTS} + \text{SIRTARGET} + \text{DPCH Constant value}$

And for uplink shared physical channels:

- $\text{PUSCH} = \alpha \text{LPCCPCH} + (1-\alpha) \text{L0} + \text{IBTS} + \text{SIRTARGET} + \text{USCH Constant value}$

Where:

- PPRACH, PDPCH, & PUSCH: Transmitter power level in dBm,
- LPCCPCH: Measurement representing path loss in dB (reference transmit power "Primary CCPCH Tx Power" is broadcast on BCH in system information blocks 5 & 6, or individually signalled to each UE in the IE "Uplink DPCH Power Control").
- L0: Long term average of path loss in dB
- IBTS: Interference signal power level at cell's receiver in dBm ("UL Interference" is broadcast on BCH in system information block 14 or individually signalled to each UE in the IE "Uplink DPCH Power Control" for each active uplink timeslot).
- α : α is a weighting parameter, which represents the quality of path loss measurements. α may be a function of the time delay between the uplink time slot and the most recent down link PCCPCH time slot. α is calculated at the UE.

- SIRTARGET: Target SNR in dB. This value is individually signalled to UEs in UL DPCH Power Control Info and PUSCH Power Control Info IEs.
- RACH Constant value: This value is broadcast on BCH and shall be read on system information blocks 5 & 6.
- DPCH Constant value: This value is broadcast on BCH and shall be read on system information blocks 5 & 6, or individually signalled to each UE in the IE "Uplink DPCH Power Control".
- USCH Constant Value: This value is broadcast on BCH and shall be read on system information blocks 5 & 6.

The UE shall:

- if in the IE "Uplink DPCH Power Control" the "CHOICE UL OL PC info" has the value "Broadcast UL OL PC info":
 - acquire Reference Power, Constant Values from SIBs 5 & 6, and IBTS for all active UL timeslots from SIB 14 on the BCH;
- otherwise:
 - acquire Reference Power, Constant Values and IBTS for all active UL timeslots from the IE "Uplink DPCH Power Control".

For PUSCH and PRACH power control the UE shall acquire Reference Power, Constant Values and IBTS for all active UL timeslots from SIBs 5,6 & 14 on the BCH.

~~8.5.9~~ — ~~Detection of in service area~~

~~When a suitable cell is found based on the description in 3GPP TS 25.304, the UE considers it as having detected "in service area".~~

8.5.10 Hyper Frame Numbers

The hyper frame numbers (HFN) are used as MSBs of both the ciphering sequence number (COUNT-C) and the integrity sequence number (COUNT-I) for the ciphering and integrity protection algorithms, respectively. For non-transparent mode radio bearers there is an uplink and downlink COUNT-C per radio bearer and an uplink and downlink COUNT-I per signalling radio bearer. For all transparent mode radio bearers there is a common uplink and a common downlink COUNT-C and a common uplink and a common downlink COUNT-I. COUNT-C and COUNT-I are defined in Security Architecture, 3GPP TS 33.102.

The following hyper frame numbers are defined:

MAC-d HFN	24 bits	MSB of COUNT-C for data sent over RLC TM
RLC UM HFN	25 bits	MSB of COUNT-C for data sent over RLC UM
RLC AM HFN	20 bits	MSB of COUNT-C for data sent over RLC AM
RRC HFN	28 bits	MSB of COUNT-I

The START value is used to initialise the 20 most significant bits of all the hyper frame numbers and the remaining bits of the hyper frame numbers are set equal to zero.

8.5.11 START

In connected mode, the START value for CN domain 'X' is calculated as

$$\text{STARTX} = \text{MSB}_{20} (\text{MAX} \{ \text{COUNT-C}, \text{COUNT-I} \mid \text{all logical channels protected with CKX and IKX} \}) + 1.$$

The STARTX value is used to initialise the 20 most significant bits of all hyper frame numbers in CN domain 'X'.

When entering idle mode the current START value for every CN domain is stored in the USIM.

8.5.12 Integrity protection

Integrity protection shall be performed on all RRC messages, with the following exceptions:

HANDOVER TO UTRAN COMPLETE

Paging Type 1

PUSCH CAPACITY REQUEST

PHYSICAL SHARED CHANNEL ALLOCATION

RRC Connection Request

RRC Connection Setup

RRC Connection Setup Complete

RRC Connection Reject

SYSTEM INFORMATION (BROADCAST INFORMATION)

SYSTEM INFORMATION CHANGE INDICATION

TRANSPORT FORMAT COMBINATION CONTROL

NOTE: MEASUREMENT REPORT needs to be studied when used on UM as in some cases there could be synchronization problems with the RRC SN.

For CCCH and each signalling radio bearer, the UE shall use two RRC hyper frame numbers,

- "Uplink RRC HFN";
- "Downlink RRC HFN".

and two message sequence numbers,

- "Uplink RRC Message sequence number";
- "Downlink RRC Message sequence number".

The above information is stored in the variable INTEGRITY_PROTECTION_INFO per CCCH and signalling radio bearer (RB 0-4).

The RRC message sequence number (RRC SN) is incremented for every integrity protected RRC message. If the same RRC message is sent repeatedly (e.g. RRC CONNECTION RELEASE, RRC CONNECTION RELEASE COMPLETE) the corresponding RRC SN is not incremented.

8.5.12.1 Integrity protection in downlink

If the UE receives an RRC message on signalling radio bearer with RB identity *n*, the "Status" in the variable INTEGRITY_PROTECTION_INFO has the value "Started" and the IE 'Integrity check info' is present the UE shall:

- check the value of the IE "RRC message sequence number" included in the IE "Integrity check info". If the RRC message sequence number is lower than or equal to the "Downlink RRC Message sequence number" for RB#*n* in the variable INTEGRITY_PROTECTION_INFO, the UE shall increment "Downlink RRC HFN" for RB#*n* in the variable INTEGRITY_PROTECTION_INFO with one.
- calculate an expected message authentication code in accordance with subclause 8.5.12.3.
- compare the expected message authentication code with the value of the received IE "message authentication code" contained in the IE 'Integrity check info'.
- If the expected message authentication code and the received message authentication code are the same, the integrity check is successful.

- If the calculated expected message authentication code and the received message authentication code differ, the message shall be discarded.

If the UE receives an RRC message on signalling radio bearer with identity n, the "Status" in the variable INTEGRITY_PROTECTION_INFO has the value "Started" and the IE 'Integrity check info' is not present the UE shall discard the message.

8.5.12.2 Integrity protection in uplink

Upon transmitting an RRC message using the signalling radio bearer with radio bearer identity n, and the "Status" in the variable INTEGRITY_PROTECTION_INFO has the value "Started" the UE shall:

- increment "Uplink RRC Message sequence number" for RB#n in the variable INTEGRITY_PROTECTION_INFO with 1. When "Uplink RRC Message sequence number" for RB#n in the variable INTEGRITY_PROTECTION_INFO becomes 0, the UE shall increment "Uplink RRC HFN" for RB#n in the variable INTEGRITY_PROTECTION_INFO with 1
- calculate the message authentication code in accordance with subclause 8.5.12.3
- replace the "Message authentication code" in the IE "Integrity check info" in the message with the calculated message authentication code.
- replace the "RRC Message sequence number" in the IE "Integrity check info" in the message with contents set to the new value of the "Uplink RRC Message sequence number" for RB#n in the variable INTEGRITY_PROTECTION_INFO

8.5.12.3 Calculation of message authentication code

The UE shall calculate the message authentication code in accordance with 3GPP TS 33.102. The input parameter MESSAGE (3GPP TS 33.102) for the integrity algorithm shall be constructed by:

- setting the "Message authentication code" in the IE "Integrity check info" in the message to the signalling radio bearer identity
- setting the "RRC Message sequence number" in the IE "Integrity check info" in the message to zero
- encoding the message
- appending RRC padding (if any) as a bitstring to the encoded bitstring as the least significant bits

8.5.13 Measurement occasion calculation

When in CELL_FACH state the UE shall perform inter-frequency and inter system measurements during the frame with the SFN value fulfilling the following equation:

$$((\text{SFN div } N) \bmod M_REP = C_RNTI \bmod M_REP)$$

where

- N is the TTI of FACH div 10ms
- $M_REP = 2k$
- $k = k_UTRA - k_Inter_RAT_tot$

where,

- $k_Inter_RAT_tot$ is the sum of all the k_Inter_RAT values corresponding to a system that the UE supports in addition to UTRA, and that have neighbours present in the measurement control message on system information sent from the current cell.
- C_RNTI is the C-RNTI value of the UE

- k_UTRA and k_Inter_RAT are read on system information in "System Information Block Type 11" or "System Information Block Type 12" in the IE "FACH measurement occasion info".

The UE is allowed to measure on other occasions in case the UE moves "out of service" area or in case it can simultaneously perform the ordered measurements.

8.5.14 Establishment of Access Service Classes

The PRACH resources (i.e. access slots and preamble signatures for FDD), timeslot (with specific frame allocation and channelization code for TDD) may be divided between different Access Service Classes in order to provide different priorities of RACH usage. It is possible for more than one ASC or for all ASCs to be assigned to the same access slot/signature space in FDD or frame allocation in TDD.

Access Service Classes shall be numbered in the range $0 \leq i \leq \text{NumASC} \leq 7$ (i.e. the maximum number of ASCs is "NumASC+1" = 8). An ASC is defined by an identifier, i , that defines a certain partition of the PRACH resources and an associated persistence value P_i . A set of ASC parameters consists of "NumASC+1" such parameters (i, P_i), $i = 0, \dots, \text{NumASC}$.

PRACH partitions shall be established using the information element "PRACH partition". The persistence values P_i to be associated with each ASC shall be derived from the dynamic persistence level $N = 1, \dots, 8$ which is broadcast in SIB 7, and the persistence scaling factors s_i , broadcast in System Information Block Type 5 and possibly also in System Information Block Type 6, as follows:

$$P(N) = 2^{-(N-1)}$$

ASC # i	0	1	2	3	4	5	6	7
P_i	1	$P(N)$	$s_2 P(N)$	$s_3 P(N)$	$s_4 P(N)$	$s_5 P(N)$	$s_6 P(N)$	$s_7 P(N)$

Scaling factors s_i are provided optionally for $i = 2, \dots, \text{NumASC}$, where NumASC+1 is the number of ASCs as defined by PRACH partitioning. If no scaling factors are broadcast, default value 1 shall be used if NumASC ≥ 2 .

If $k \geq 1$ scaling factors are broadcast and NumASC $\geq k+2$ then the last scaling factor s_{k+1} shall be used as default for the ASCs where $i > k+1$.

The set of ASC parameters is provided to MAC with the CMAC-Config-REQ primitive (see TS 25.321), the PRACH partitioning is provided to PHY using the CPHY-TrCH-Config-REQ primitive (see TS 25.302).

The ASC enumeration shall be such that it corresponds to the order of priority (ASC 0 = highest priority, ASC 7 = lowest priority). ASC 0 shall be used in case of Emergency Call or for reasons with equivalent priority.

At radio bearer setup/reconfiguration each involved logical channel is assigned a MAC Logical channel Priority (MLP) in the range 1, ..., 8. When the MAC sublayer is configured for RACH transmission in the UE, these MLP levels shall be employed for ASC selection on MAC.

8.5.15 Mapping of Access Classes to Access Service Classes

Access Classes shall only be applied at initial access, i.e. when sending an RRC CONNECTION REQUEST message. A mapping between Access Class (AC) and Access Service Class (ASC) shall be indicated by the information element "AC-to-ASC mapping" in SIB 5. The correspondence between AC and ASC shall be indicated as follows.

AC	0 - 9	10	11	12	13	14	15
ASC	1st IE	2nd IE	3rd IE	4th IE	5th IE	6th IE	7th IE

In the table, "nth IE" designates an ASC number i in the range 0 - 7 to AC.

For the random access, the parameters implied by the respective ASC shall be employed. In case the UE is member of several ACs it shall select the ASC for the highest AC number. In connected mode, AC shall not be applied.

8.5.16 PLMN Type Selection

The UE shall perform PLMN selection and reselection as stated in 3GPP TS 25.304 and store the identifier of the chosen PLMN in the variable `SELECTED_PLMN` as follows:

- If a GSM-MAP type of PLMN is selected, the UE shall set the "PLMN Type" in the variable `SELECTED_PLMN` to "GSM-MAP" and store the PLMN identity of that PLMN.
- If an ANSI-41 type of PLMN is selected, the UE shall set the "PLMN Type" in the variable `SELECTED_PLMN` to "ANSI-41" and store the System identification (SID) of that PLMN.

8.5.17 CFN calculation

8.5.17.1 Initialization in CELL_DCH state on transiting from CELL_FACH state

When the UE changes from CELL_FACH state to CELL_DCH state CFN shall be calculated according to the following formula:

- for FDD:

$$\text{CFN} = ((\text{SFN} * 38400 - \text{DOFF} * 512) \text{ div } 38400) \text{ mod } 256$$

- for TDD:

$$\text{CFN} = (\text{SFN} - \text{DOFF}) \text{ mod } 256$$

8.5.17.2 Initialization in CELL_DCH state at hard handover

When the UE is in CELL_DCH state and receives any of the messages causing the UE to perform a hard handover, the UE shall check the IE "Timing indication" in that message.

- if IE "Timing indication" has the value "initialise" (i.e. non-synchronised hard handover), CFN shall be calculated according to the following formula:
 - for FDD:
 - $\text{CFN} = ((\text{SFN} * 38400 - \text{DOFF} * 512) \text{ div } 38400) \text{ mod } 256;$
 - for TDD:
 - $\text{CFN} = (\text{SFN} - \text{DOFF}) \text{ mod } 256;$
- if IE "CFN-targetSFN frame offset" is included in the message causing the UE to perform a non-synchronised hard handover, CFN shall be calculated according to the following formula:
 - for FDD:
 - $\text{CFN}_{\text{new}} = (\text{CFN}_{\text{old}} * 38400 + \text{COFF} * 38400 - \text{DOFF} * 512) \text{ div } 38400) \text{ mod } 256$
 - for TDD:
 - $\text{CFN}_{\text{new}} = (\text{CFN}_{\text{old}} + \text{COFF} - \text{DOFF}) \text{ mod } 256$
 - where COFF is the value of "CFN-targetSFN frame offset".
- if IE "CFN-targetSFN frame offset" is not included the UE shall read SFN on target cell.

NOTE: $\text{CFN-targetSFN frame offset} = (\text{TargetSFN} - \text{CFN}) \text{ mod } 256$

- if IE "Timing indication" has the value "maintain" (i.e. synchronised hard handover), the UE shall keep CFN with no change due to the hard handover, and only increase CFN (mod 256) by 1 every frame.

8.5.17.3 Initialization for CELL_FACH

When the UE performs cell selection, re-selection or changes to CELL_FACH state the UE shall set CFN for all common or shared channels according to:

- $CFN = SFN \bmod 256$

After the initialization, the CFN in the UE is increased (mod 256) by 1 every frame.

8.5.18 Unrecoverable RLC error

8.6 Generic actions on receipt and absence of an information element

8.6.1 CN information elements

8.6.1.1 CN domain specific DRX cycle length coefficient

The UE updates CN domain specific DRX cycle length coefficient as specified in [4]. The UE shall use it to calculate the CN domain specific DRX cycle length, according to the following:

- set k to the value of the IE "CN domain specific DRX cycle length coefficient".
- store the result of $2k * PBP$, where PBP is the Paging Block Periodicity, as the CN domain specific DRX cycle length for the CN domain indicated by the IE "CN domain identity". For FDD PBP=1.

The UE shall determine its idle mode paging occasions and PICH monitoring occasions for that CN domain, according to TS 25.304, based on the stored CN domain specific DRX cycle length, when using DRX in idle mode.

8.6.1.2 ~~NAS system~~ CN information info

If the IE "CN information info" is "~~CN domain identity~~" and the IE "~~NAS system information~~" are present in a message, the UE shall

- if present, forward the content of the IE "PLMN identity" to upper layer entities of all CN domains
- if present, forward the content of the IE "CN common GSM-MAP NAS system information" to upper layer entities of all CN domains
- if the IE "CN domain related information" is present, forward the content of the IE "CN domain specific GSM-MAP NAS system info ~~NAS system information~~" to the non-access stratum entity of the UE indicated by the IE "CN domain identity".

8.6.2 UTRAN mobility information elements

8.6.2.1 URA identity

The UE shall:

- if the IE "URA identity" is included in a received message:
- if the IE "~~DRX indicator~~ RRC State Indicator" is included and set to "DRX with URA updating":
 - store this URA identity in the variable URA_IDENTITY;
- after sending a possible message to UTRAN and entering URA_PCH state as specified elsewhere, read system information block type 2 in the selected cell;

- if the stored URA identity in the variable URA_IDENTITY is not included in the list of URA identities in system information block type 2 in the selected cell, a confirmation error of URA identity list has occurred:
 - if no URA update procedure is ongoing:
 - initiate a URA update procedure after entering URA_PCH state, see subclause 8.3.2.2.
 - if a URA update procedure is ongoing:
 - take actions as specified in subclause 8.3.2.6.
- if the IE "URA identity" is not included in a received message:
 - the IE "~~DRX indicator~~RRC State Indicator" is included and set to "DRX with URA updating":
 - after sending a possible message to UTRAN and entering URA_PCH state as specified elsewhere, read system information block type 2 in the selected cell;
 - if system information block type 2 in the selected cell contains a single URA identity:
 - store this URA identity in the variable URA_IDENTITY;
 - if system information block type 2 of the selected cell contains more than one URA identity, a confirmation error of URA identity list has occurred:
 - if no URA update procedure is ongoing:
 - initiate a URA update procedure after entering URA_PCH state, see subclause 8.3.2.2.
 - if a URA update procedure is ongoing:
 - take actions as specified in subclause 8.3.2.6.

8.6.3 UE information elements

8.6.3.1 Activation time

If the IE "Activation time" is present, the UE shall:

- activate the new configuration present in the same message as this IE at the indicated time.

NOTE: The new configuration is typically a dedicated physical channel present in the same message as the IE "Activation time".

8.6.3.2 UTRAN DRX Cycle length coefficient

If the IE "UTRAN DRX cycle length coefficient" is present, the UE shall use it to calculate the UTRAN DRX cycle length, according to the following:

- set k to the value of the IE "UTRAN DRX cycle length coefficient";
- store the result of $2k * PBP$, where PBP is the Paging Block Periodicity, as the DRX cycle length.

The UE shall determine its connected mode paging occasions and PICH monitoring occasions in the same way as for idle mode, according to TS 25.304.

The DRX cycle length to use in connected mode is the shorter of the following two parameters:

- UTRAN DRX cycle length;
- CN domain specific DRX cycle length stored for any CN domain, when using Discontinuous Reception (DRX) in CELL_PCH and URA_PCH state.

The CN domain specific DRX cycle length stored for any CN domain is only used in Cell_PCH state and URA_PCH state if the UE is registered to that CN domain and no signalling connection exists to that CN domain.

8.6.3.3 DRX Indicator RRC State Indicator

If the IE "DRX Indicator RRC State Indicator" is set to 'DRX with cell updating', the UE shall:

- if the IE "UTRAN DRX cycle length coefficient" is included in the same message, use the value in the IE "UTRAN DRX Cycle length coefficient" for calculating Paging Occasion and PICH Monitoring Occasion as specified in 8.6.3.2 in CELL_PCH state.

If the IE "DRX Indicator RRC State Indicator" is set to 'DRX with URA updating', the UE shall:

- if the IE "UTRAN DRX cycle length coefficient" is included in the same message, use the value in the IE "UTRAN DRX Cycle length coefficient" for calculating Paging occasion and PICH Monitoring Occasion as specified in 8.6.3.2 in URA_PCH state.

If the IE "DRX Indicator RRC State Indicator" set to 'no DRX' the UE shall:

- if the IE "UTRAN DRX cycle length coefficient" is included in the same message:
 - ignore that IE;
- stop using DRX.

If:

- the IE "RRC State Indicator" is set to CELL_DCH but no DPCH is assigned the UE shall set the variable INVALID_CONFIGURATION to TRUE, or
- the received message is RRC CONNECTION SETUP and IE "RRC State Indicator" is set to CELL_PCH or URA_PCH, the UE shall transmit a new RRC CONNECTION SETUP REQUEST message as per subclause 8.1.3.6.

8.6.3.4 Ciphering mode info

The IE "Ciphering mode info" defines the new ciphering configuration. If the IE "Ciphering mode info" is present, the UE shall check the IE "Ciphering mode command" as part of the IE "Ciphering mode info", and perform the following:

- if IE "Ciphering mode command" has the value "start/restart", the UE shall:
 - start or restart ciphering, using the ciphering algorithm (UEA [3GPP TS 33.102]) indicated by the IE "Ciphering algorithm" as part of the new ciphering configuration. The new ciphering configuration shall be applied as specified below.
 - set the variable CIPHERING_STATUS to "Started".
- if the IE "Ciphering mode command" has the value "stop", the UE shall
 - stop ciphering. The new ciphering configuration shall be applied as specified below
 - set the variable CIPHERING_STATUS to "Not started".
- in case the IE "Ciphering mode command" has the value "start/restart" or "stop", the new ciphering configuration shall be applied as follows:
 - if the IE "Activation time for DPCH" is present in the IE "Ciphering mode info", the UE shall apply the new configuration at that time for radio bearers using RLC-TM.
 - if the IE "Radio bearer downlink ciphering activation time info" is present in the IE "Ciphering mode info", the UE shall apply the following procedure for each radio bearer using RLC-AM and RLC-UM indicated by the IE "RB identity":
 - suspend data transmission on the radio bearer
 - store the "RLC send sequence number" for that radio bearer in the variable RB_UPLINK_CIPHERING_ACTIVATION_TIME_INFO, at which time the new ciphering configuration shall be applied.

- when the data transmission of that radio bearer is resumed, the UE shall switch to the new ciphering configuration according to the following:
 - use the old ciphering configuration for the transmitted and received RLC PDUs with RLC sequence number smaller than the corresponding RLC sequence number indicated in the IE "Radio bearer uplink ciphering activation time info" sent to UTRAN respectively in the received IE "Radio bearer downlink ciphering activation time info" received from UTRAN.
 - use the new ciphering configuration for the transmitted and received RLC PDUs with RLC sequence number greater than or equal to the corresponding RLC sequence number indicated in the IE "Radio bearer uplink ciphering activation time info" sent to UTRAN respectively in the received IE "Radio bearer downlink ciphering activation time info" received from UTRAN
 - for a radio bearer using RLC-AM, when the RLC sequence number indicated in the IE "Radio bearer downlink ciphering activation time info" is not included in the RLC transmission window, the UE may release the old ciphering configuration for that radio bearer.

If the IE "Ciphering mode info" is not present, the UE shall not change the ciphering configuration.

8.6.3.5 Integrity protection mode info

The IE "Integrity protection mode info" defines the new integrity protection configuration. If the IE "Integrity protection mode info" is present, the UE shall check the IE "Integrity protection mode command" as part of the IE "Integrity protection mode info", and perform the following:

- if IE "Integrity protection mode command" has the value "start" and the "Status" in the variable INTEGRITY_PROTECTION_INFO has the value "Not started", the UE shall:
 - set the "Status" in the variable INTEGRITY_PROTECTION_INFO to the value "Started";
 - perform integrity protection on the received message as described in subclause 8.5.12.1;
 - use the algorithm (UIA [3GPP TS 33.102]) indicated by the IE "Integrity protection algorithm" contained in the IE "Integrity protection mode info";
 - use the IE "Integrity protection initialization number", contained in the IE "Integrity protection mode info" as the value of FRESH [3GPP TS 33.102].
- if IE "Integrity protection mode command" has the value "modified" and the "Status" in the variable INTEGRITY_PROTECTION_INFO has the value "Started", the UE shall:
 - use the new integrity protection configuration in the downlink at the RRC sequence number indicated by the IE "Downlink integrity protection activation info", included in the IE "Integrity protection mode info";
 - perform integrity protection on the received message as described in subclause 8.5.12.1;
 - if present, use the algorithm indicated by the IE "Integrity protection algorithm" (UIA [TS 33.102]);
 - set the values of the IE "Uplink integrity protection activation info";

If the IE "Integrity protection mode info" is not present, the UE shall not change the integrity protection configuration.

8.6.3.6 Configuration of CTCH occasions

The CTCH, carrying CBS data is mapped onto only one S-CCPCH. If more than one CTCH is defined, the first CTCH that is configured in the list of S-CCPCHs is the one that is used for CBS data.

The CTCH occasions are identified by the first radio frame of the TTI which can contain CTCH data. The CTCH occasions are fixed on the system frame number cycle 0 .. 4095 (i.e. no modulo calculation) and thus repeated cyclically.

The CTCH occasions are determined by a set of parameters.

MTTI: number of radio frames within the TTI of the FACH used for CTCH

N: period of CTCH allocation on S-CCPCH, integer number of radio frames,
 $MTTI \leq N \leq \text{MaxSFN} - K$, where N is a multiple of MTTI (see 3GPP TS 25.212 and 3GPP TS 25.222).

MaxSFN: maximum system frame number = ~~4096~~ 4095 (see 3GPP TS 25.402).

K: CBS frame offset, integer number of radio frames $0 \leq K \leq N-1$ where K is a multiple of MTTI .

The CTCH occasions are calculated as follows:

$\text{SFN} = (K + m N)$, $m = 0, 1, \dots, M$, M chosen that $K + MN \leq \text{MaxSFN}$.

The parameters N and K are broadcast as system information.

8.6.3.7 UL Timing Advance

If the IE "UL Timing Advance Control" is present, the UE shall:

- if IE "Uplink Timing Advance Control" has the value "disabled":
 - reset timing advance to 0;
 - disable calculated timing advance following handover;
 - in case of handover start uplink transmissions in the target cell without applying timing advance;
- if IE "Uplink Timing Advance Control" has the value "enabled":
 - evaluate and apply the timing advance value for uplink transmission as indicated in IE "Uplink Timing Advance" at the CFN indicated in the IE "Activation Time";
 - enable UE autonomous timing advance calculation for handover;
 - update uplink timing advance as indicated in IE "Uplink Timing Advance" in advance of the UE autonomous timing advance calculation

8.6.3.8 Integrity check info

If the IE "Integrity check info" is present the UE shall act as described in subclause 8.5.12.1.

8.6.3.9 New C-RNTI

If the IE "New C-RNTI" is included, the UE shall:

- store the value in the variable C_RNTI, replacing any old stored value;
- use that C-RNTI when using common transport channels of type RACH, FACH and CPCH in the current cell.

8.6.3.10 New U-RNTI

If the IE "New U-RNTI" is included in an received message, the UE shall:

- store the value in the variable U_RNTI, replacing any old stored value.

8.6.3.11 RRC transaction identifier

If the IE "RRC transaction identifier" is included in a received message, the UE shall:

- If the IE "Message Type" of the received message is not present in the table "Accepted transactions" in the variable TRANSACTIONS, and;
- if the received message does not contain a protocol error according to clause 16 and the variable PROTOCOL_ERROR_REJECT is set to FALSE;
- accept the transaction, and;

- store the IE "Message type" and the IE "RRC transaction identifier" of the received message in the table "Accepted transactions" in the variable TRANSACTIONS;
- else if the IE "Message Type" of the received message is present in the table "Accepted transactions" in the variable TRANSACTIONS, or;
- if the received message contains a protocol error according to clause 16 causing the variable `PROTOCOL_ERROR_REJECT` to be set to TRUE;
- if the IE "RRC transaction identifier" of the received message is identical to the "RRC transaction identifier" stored for the "Message Type" in the table "Accepted transactions" in the variable TRANSACTIONS;
 - ignore the transaction, and;
 - resume normal operation as the message was not received and end the procedure;
- else if the IE "RRC transaction identifier" of the received message is different from the "RRC transaction identifier" stored for the "Message Type" in the table "Accepted transactions" in the variable TRANSACTIONS;
 - reject the transaction, and;
 - if the IE "Message Type" of the received message is not present in the table "Rejected transactions" in the variable TRANSACTIONS;
 - store the IE "Message type" and the IE "RRC transaction identifier" of the received message in the table "Rejected transactions" in the variable TRANSACTIONS;

8.6.4 Radio bearer information elements

8.6.4.1 RB mapping info

If the IE "RB identity" and the IE "RB mapping info" are included, the UE shall:

- for each RB:
 - delete all previously stored multiplexing options for that radio bearer;
 - store each new multiplexing option for that radio bearer;
- use the multiplexing options applicable for the transport channels to be used;
- configure MAC multiplexing if that is needed in order to use those transport channels;
- use "MAC logical channel priority" when selecting TFC in MAC.

8.6.4.2 RLC Info

If the IE "RB identity" and the IE "RLC Info" are included, the UE shall:

- Configure the transmitting and receiving RLC entities in the UE for that radio bearer accordingly.

8.6.4.3 PDCP Info

If the IEs "RB identity" and "PDCP info" are included, the UE shall:

- Configure the PDCP entity for that radio bearer accordingly.

8.6.4.4 Signalling RB information to setup

If the IE "Signalling RB information to setup" is included the UE shall:

- use the value of the IE "RB identity" as the identity of the signalling radio bearer to setup;

~~perform the actions for the IE "RLC info" as specified in subclause 8.6.4.2, applied for that signalling radio bearer;~~

~~perform the actions for the IE "RB mapping info" as specified in subclause 8.6.4.1, applied for that signalling radio bearer.~~

8.6.4.54 Signalling RB information to setup list

If the IE "Signalling RB information to setup list" is included the UE shall:

- ~~for each occurrence of the IE "Signalling RB information to setup", apply the following actions according to subclause 8.6.4.4.:~~
- ~~use the value of the IE "RB identity" as the identity of the signalling radio bearer to setup;~~
- ~~perform the actions for the IE "RLC info" as specified in subclause 8.6.4.2, applied for that signalling radio bearer;~~
- ~~perform the actions for the IE "RB mapping info" as specified in subclause 8.6.4.1, applied for that signalling radio bearer.~~
- ~~apply a default value of the IE "RB identity" equal to 1 for the first IE "Signalling RB information to setup" and increase the default value by 1 for each occurrence~~

8.6.5 Transport channel information elements

8.6.5.1 Transport Format Set

If the IE "transport channel identity" and the IE "Transport format set" is included, the UE shall:

- store the transport format set for that transport channel.

If the IE "Transport format Set" has the choice "Transport channel type" set to "Dedicated transport channel", the UE shall:

- Calculate the transport block size for all transport formats in the TFS using the following

$$\text{TB size} = \text{RLC PDU size} + \text{MAC header size},$$

where:

- MAC header size is calculated according to 3GPP TS 25.321 if MAC multiplexing is used. Otherwise it is 0 bits.

8.6.5.2 Transport format combination set

If the IE "Transport format combination set" is included, the UE shall for that direction (uplink or downlink):

- remove a previously stored transport format combination set if this exists;
- store the new transport format combination set present in the IE "Transport format combination set";
- start to respect those transport format combinations.

For downlink CCTrCHs if no TFCS is stored in the UE the UE shall consider all possible transport format combinations and calculate the possible TFCI values according to the IE transport format combination set.

For downlink CCTrCHs if a TFCS is stored in the UE and

- if the IE "Transport format combination set" is not included and transport channels are deleted in the message, the UE shall:
 - remove the affected transport format combinations from the transport format combination set, recalculate the TFCI values and start to respect those transport format combinations

- if the IE "Transport format combination set" is not included and transport channels are added in the message, the UE shall:
 - consider all possible new combinations to be valid and recalculate the TFCI values and start to respect those transport format combinations. In TDD the new transport format combinations are considered to belong to the TFCS with the ID 1 of DCH type.
- if the IE "Transport format combination set" is not included and transport channels are replaced the UE shall:
 - consider all possible transport format combinations to be valid and calculate the TFCI values accordingly.

If the IE "Transport format combination set" is not included, the TFCI ordering shall correspond to the CTFC ordering.

8.6.5.3 Transport format combination subset

If the IE "Transport format combination subset" is included, the UE shall:

- restrict the transport format combination set in the uplink to that transport format combination subset. If the transport format combination subset indicates the "full transport format combination set" any restriction on transport format combination set is released and the UE may use the full transport format combination set.

8.6.6 Physical channel information elements

8.6.6.1 Frequency info

If the IE "Frequency info" is included the UE shall:

- Store that frequency as the active frequency; and
- Tune to that frequency.

If the IE "Frequency info" is not included and the UE has a stored active frequency, the UE shall

- Continue to use the stored active frequency.

8.6.6.2 PRACH info and PRACH selection

The UE shall select a PRACH according to the following rule. The UE shall:

- if the IE "PRACH info" is included in a dedicated message (in Connected Mode only):
 - release any active dedicated physical channels in the uplink;
 - let the PRACH be the default in the uplink for RACH;
- if the IE "PRACH info" is not included in a dedicated message:
 - select a default PRACH from the ones indicated in the IE "PRACH info" in System Information Block type 5 (applicable in Idle Mode and Connected Mode) and System Information Block type 6 (applicable in Connected Mode only), as follows:
 - if both RACH with 10 ms and 20 ms TTI are indicated in SIB 5 and SIB 6:
 - select the appropriate TTI based on power requirements, as specified in subclause 8.5.7.6.3/8.6.6.3;
 - select a RACH randomly from the ones listed in SIB 5 and SIB 6 as follows:

"Index of selected PRACH" = floor (rand * K)

where K is equal to the number of listed PRACHs which carry an RACH with the above selected TTI, "rand" is a random number uniformly distributed in the range 0,...,1, and "floor" refers to rounding down to nearest integer. RACHs with 10 and 20 ms TTI shall be counted separately. These RACHs shall be indexed from 0 to K-1 in the order of their occurrence in SIB 5 and SIB 6, where RACHs listed in SIB 5 shall be counted first. The random number generator is left to implementation. The scheme shall be

implemented such that one of the available RACHs is randomly selected with uniform probability. At startup of the random number generator in the UE the seed shall be dependent on the IMSI of the UE or time, thereby avoiding that all UEs select the same RACH;

- reselect the default PRACH when a new cell is selected. RACH reselection may also be performed after each transmission of a Transport Block Set on RACH;
- for emergency call, the UE is allowed to select any of the available RACHs.

8.6.6.3 Selection of RACH TTI

In FDD mode, a RACH may employ either 10 or 20 ms TTI. The supported TTI is indicated as a semi-static parameter of the RACH Transport Format in system information. If in one cell RACHs for both 10 and 20 ms TTI are supported, the UE shall select an appropriate RACH according to the following rule:

The UE shall first check whether a RACH Transport Format is available which is suitable for the transmission of the current transport Block Set for both 10 and 20 ms TTI. The UE shall:

- if the required transport format is available only for one particular TTI:
 - select this TTI;
 - identify the corresponding RACHs;
 - proceed with RACH selection as specified in subclause ~~8.5.7.6.2~~8.6.6.2.
- if the required transport format is available on both types of RACH, 10 and 20 ms TTI:
 - perform TTI selection as follows:
 - when the UE calculates the initial preamble transmit power ("Preamble_Initial_Power") as specified in subclause ~~8.5.98.5.8~~8.5.8:
 - calculate a transmit power margin,

$$\text{Margin} = \{ \min(\text{Maximum allowed UL tx power, P_MAX}) - \max(\text{Preamble_Initial_Power, Preamble_Initial_Power} + \Delta P_{p-m} + 10 \cdot \log_{10}(1 + (\beta_d / \beta_c)^2) \}$$

where "Maximum allowed UL tx power" is the maximum allowed uplink transmit power indicated in system information (in dBm), and P_MAX is the maximum RF output power of the UE (dBm). The margin shall be calculated for 10 ms TTI RACH message gain factors β_d and β_c .

NOTE: the expression $\text{Preamble_Initial_Power} + \Delta P_{p-m} + 10 \cdot \log_{10}(1 + (\beta_d / \beta_c)^2)$ represents the total RACH message power if the message would be sent after the initial preamble.

- if the value of "Margin" calculated for RACH with 10 ms TTI is less than 6 dB:
 - decide for RACH with 20 ms TTI, and proceed as specified in subclause ~~8.6.6.28.5.7.6.~~
- perform reselection of the RACH TTI only after successful transmission of one Transport Block Set. However in case L1 message transmission on PRACH has failed at least once while using 10 ms TTI, the UE may use the 20 ms TTI RACH for the retransmission. Handling of RACH Message transmission failure is part of general error handling procedure.

8.6.6.3a Downlink information for each radio link

If the IE "Downlink information for each radio link" is included in a received message, the UE shall:

- if the UE would enter CELL_DCH state according to subclause 8.5.7 applied on the received message:
 - if the IE "Secondary CCPCH info" is included, and:
 - the UE is not capable of simultaneous reception of DPCH and Secondary CCPCH:
 - set the variable UNSUPPORTED_CONFIGURATION to TRUE;

- else if the UE is capable of simultaneous reception of DPCH and SCCPCH:
- start to receive the indicated Secondary CCPCH;
- act on the other IEs contained in the IE "Downlink information for each radio link" as specified in subclause 8.6.
- if the UE would enter either the CELL_FACH, CELL_PCH or URA_PCH state according to subclause 8.5.7 applied on the received message:
- set the variable INVALID_CONFIGURATION to TRUE.

8.6.6.4 Secondary CCPCH info

In UTRAN Connected mode, the UE shall select the Secondary CCPCH according to the following rules:

- in Cell_DCH state:
 - if the IE "Secondary CCPCH info" is included within a message sent on DCCH, the UE shall start to receive the indicated Secondary CCPCH in the downlink select Secondary CCPCH according to subclause 8.6.6.3a;
- in Cell_FACH state:
 - select an SCCPCH from the SCCPCHs listed in System Information Block types 5 and 6 (SIB 5 and SIB 6) based on U-RNTI as follows:

"Index of selected SCCPCH" = U-RNTI mod K,

where K is equal to the number of listed SCCPCHs which carry a FACH (i.e., SCCPCHs carrying PCH only shall not be counted). These SCCPCHs shall be indexed from 0 to K-1 in the order of their occurrence in SIB 5 and SIB 6, and "Index of selected SCCPCH" identifies the selected SCCPCH. SCCPCHs included in SIB 5 shall be indexed first.

in Cell_PCH and URA_PCH states:

- select an SCCPCH from the SCCPCHs listed in SIB 5 and SIB 6 based on U-RNTI as follows:

"Index of selected SCCPCH" = U-RNTI mod K,

where K is equal to the number of listed SCCPCHs which carry a PCH (i.e., SCCPCHs carrying FACH only shall not be counted). These SCCPCHs shall be indexed in the order of their occurrence in system information from 0 to K-1, and "Index of selected SCCPCH" identifies the selected SCCPCH.

UE shall set CFN in relation to SFN of current cell according to 8.5.17.

8.6.6.5 Uplink DPCH info

If the IE "Uplink DPCH info" is included, the UE shall:

- release any active uplink physical channels and activate the given physical channels.

8.6.6.6 Downlink DPCH info

If the IE "Downlink DPCH info" is included, the UE shall:

- activate the dedicated physical channels indicated by that IE.

If the IE "Downlink DPCH info" is included in a message used to establish the first RL(s) for a UE or perform a non-synchronised hard handover, the UE shall, after having activated the dedicated physical channels indicated by that IE:

- set CFN in relation to SFN of the first RL (cell) listed in that message, according to subclause 8.5.17;

If the IE "Downlink DPCH info" is included in a message used to perform a non-synchronised hard handover, and ciphering is active for any radio bearer using RLC-TM, the UE shall, after having activated the dedicated physical channels indicated by that IE:

- increment HFN for RLC-TM by '1';

If the IE "Downlink DPCH info" is included in a message used to perform a synchronised hard handover, UE shall, after having activated the dedicated physical channels indicated by that IE:

- increase CFN (mod 256) by 1 every frame and maintain UL transmission timing.

8.6.6.7 Maximum allowed UL TX power

If the IE "Maximum allowed UL TX power" is included, the UE shall:

- keep the UE uplink transmit power below the indicated power value. If the current UE uplink transmit power is above the indicated power value, the UE shall decrease the power to a level below the power value.

The maximum UE transmitter power is defined as the lower of the maximum output power of the UE power class and the maximum allowed UL TX power indicated in this IE. The maximum UE transmitter power shall not be exceeded.

8.6.6.8 PDSCH with SHO DCH Info (FDD only)

If the IE "PDSCH with SHO DCH Info" is included, the UE shall:

- configure itself such that when an allocation on the DSCH is made it will receive the PDSCH from the specified BS within the active set;

and in cases where the TFCI for the user in question has a 'hard' split (meaning that TFCI(field 1) and TFCI (field 2) have their own individual block coding):

- configure the Layer 1 to only soft combine the DPCCCH TFCI(field 2) of the radio links within the associated DCH active set which are specified;
- infer that the set of radio links for which TFCI (field 2) should be soft combined will include all radio links within the active set if the IE "TFCI combining set" is not included and the sending of the message in which the IE "PDSCH with SHO DCH Info" is being used will result in a transport channel switch from a state in which the DSCH transport channel was not available to a state in which it is available.

8.6.6.9 PDSCH code mapping (FDD only)

If the IE "PDSCH code mapping" is included, the UE shall:

- Configure Layer 1 to support the mapping of TFCI(field 2) values to PDSCH channelization codes as specified in the IE.

8.6.6.10 Uplink DPCH power control info

The UE shall:

- in FDD:
 - if the IE "Uplink DPCH power control info" is included:
 - calculate and set an initial uplink transmission power;
 - start inner loop power control as specified in 8.5.3;
 - for the UL inner loop power control:
 - use the parameters specified in the IE.
- in TDD:
 - if the IE "Uplink DPCH power control info" is included:
 - use the parameters specified in the IE for open loop power control as defined in 8.5.8.
- both in FDD and TDD;

- if the IE "Uplink DPCH power control info" is not included:
 - use the current uplink transmission power.

8.6.6.11 Secondary CPICH info

If the IE Secondary CPICH info is included, the UE:

- May use the channelization code according to IE "channelization code", with scrambling code according to IE "DL scrambling code" in the IE "Secondary CPICH info", for channel estimation of that radio link;
- May use the pilot bits on DPCCH for channel estimation.

8.6.6.12 Primary CPICH usage for channel estimation

If the IE "Primary CPICH usage for channel estimation" is included and has the value "Primary CPICH may be used" the UE:

- may use the Primary CPICH for channel estimation;
- may use the pilot bits on DPCCH for channel estimation.

If the IE "Primary CPICH usage for channel estimation" is included and has the value "Primary CPICH shall not be used" the UE:

- shall not use the Primary CPICH for channel estimation;
- may use the Secondary CPICH for channel estimation
- may use the pilot bits on DPCCH for channel estimation.

8.6.6.13 DPCH frame offset

If the IE "DPCH frame offset" is included the UE shall:

- use its value to determine the beginning of the DPCH frame

8.6.6.14 DPCH Compressed mode info

If the IE "DPCH compressed mode info" is included, and if the IE group "transmission gap pattern sequence configuration parameters" are included, the UE shall:

- delete all previously stored compressed mode pattern sequences;
- store each pattern sequence to the variable TGPS_IDENTITY according to the IE "TGPSI";
- store into the variable TGPS_IDENTITY the configuration information defined by IE group "transmission gap pattern sequence configuration parameters";
- activate the stored pattern sequence corresponding to each IE "TGPSI" for which the "TGPS status flag" is set to "activate" and begin the inter-frequency and/or inter-system measurements corresponding to the pattern sequence measurement purpose of each activated pattern sequence;
- monitor if the parallel transmission gap pattern sequences create an illegal overlap, and in case of overlap, take actions as specified in 8.2.11.2;

If the IE "DPCH compressed mode info" is included, and if the IE group "transmission gap pattern sequence configuration parameters" is not included, the UE shall:

- activate the stored pattern sequence corresponding to each IE "TGPSI" for which the "TGPS status flag" is set to "activate" and begin the inter-frequency and/or inter-system measurements corresponding to the pattern sequence measurement purpose of each activated pattern sequence;

- deactivate the stored pattern sequence corresponding to each IE "TGPSI" for which the "TGPS status flag" is set to "deactivate" and terminate the inter-frequency and/or inter-system measurements corresponding to the pattern sequence measurement purpose of each deactivated pattern sequence;

8.6.6.15 Repetition period, Repetition length, Offset

The following description applies to TDD only.

The frame allocation can be derived by following rules:

If no IE "Offset" is explicitly given, the parameter "Offset" to be used is calculated by the following equation:

$$\text{Activation time mod Repetition period} = \text{Offset.}$$

Frames from CFN CFN_{off} to CFN_{off} + Repetition length belong to the allocation with CFN_{off} fulfilling the following equation:

$$\text{CFN}_{\text{off}} \text{ mod Repetition period} = \text{Offset.}$$

Repetition length is always a multiple of the largest TTI within the CCTrCH fulfilling the following equation:

$$(\text{largest TTI within CCTrCH}) * X = \text{Repetition Length}$$

Example of usage:

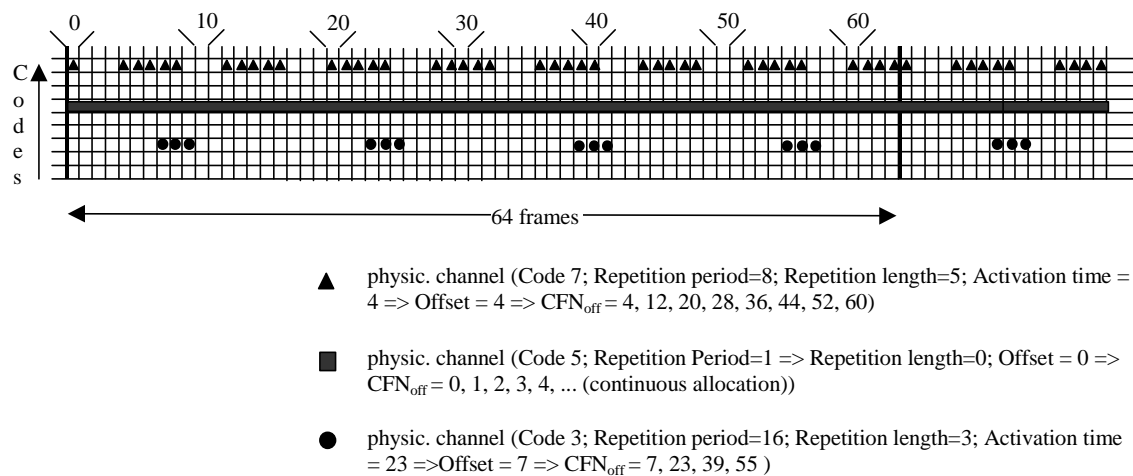

Figure 58: Examples for frame allocations in TDD

8.6.6.16 Primary CCPCH info

If the IE "Primary CCPCH info" in TDD and the IE "New C-RNTI" are included and the message including these IEs is used to initiate a state transition to CELL_FACH, the UE shall:

- select the cell indicated by the IE "Primary CCPCH info";
- use the given C-RNTI when using common transport channels of type RACH, FACH and CPCH in that given cell after having completed the transition to that cell.

8.6.6.17 Primary CPICH info

If the IE "Primary CPICH info" in FDD and the IE "New C-RNTI" are included and the message including these IEs is used to initiate a state transition to CELL_FACH, the UE shall:

- select the cell indicated by the IE "Primary CPICH info";

- use the given C-RNTI when using common transport channels of type RACH, FACH and CPCH in that given cell after having completed the transition to that cell.

8.6.6.18 CPCH SET Info (FDD only)

If the UE has the capability to use CPCH, the UE shall use the following general procedures:

- if an IE "CPCH SET Info" is included in a dedicated message:
 - read the "CPCH set ID" included in the IE;
 - store the IE using the "CPCH set ID" as an address tag;
 - release any active dedicated physical channels in the uplink;
 - let the PCPCHs listed in the CPCH set be the default in the uplink for CPCH;
- if an IE "CPCH SET Info" is included in a System Information message:
 - read the "CPCH set ID" included in the IE;
 - store the IE using the "CPCH set ID" as an address tag.

8.6.6.19 CPCH set ID (FDD only)

If the UE has the capability to use CPCH, the UE shall use the following general procedures:

- If an IE "CPCH set ID" is included in a dedicated message and not as part of IE "CPCH SET Info":
 - use the IE as an address tag to retrieve the corresponding stored "CPCH SET Info";
 - release any active dedicated physical channels in the uplink;
 - let the PCPCHs listed in the CPCH set be the default in the uplink for CPCH.
- if an IE "CPCH set ID" is included in a dedicated message and not as part of IE "CPCH SET Info", and if there is no corresponding stored "CPCH SET Info":
 - release any active dedicated physical channels in the uplink;
 - let the last assigned PRACH be the default in the uplink for RACH;
 - obtain current System Information on SCCPCH to obtain and store the "CPCH SET info" IE(s);
 - upon receipt of a "CPCH SET Info" which corresponds to the "CPCH set ID" IE:
 - let the PCPCHs listed in that CPCH set be the default in the uplink for CPCH.

8.6.6.20 Default DPCH Offset Value

The UE shall:

- if the IE "Default DPCH Offset Value" is included:
 - use its value to determine Frame Offset and Chip Offset from the SFN timing in a cell;
- if the IE "Default DPCH Offset Value" is not included:
 - use the previously received value stored in variable DOFF. If there is no previously received value stored in DOFF, the UE should use the value 0.

After transition from CELL_DCH state to other states, the UE shall erase the value stored in variable DOFF.

8.6.6.21 Secondary Scrambling Code, Code Number

The following description applies to FDD.

Code Number can be assigned by following rules:

- When more than one DL DPDCH is assigned per RL, the segmented physical channel shall be mapped on to DL DPDCHs according to 3GPP TS 25.212. When p number of DL DPDCHs are assigned to each RL, the first pair of Secondary Scrambling Code and Code Number corresponds to "PhCH number 1", the second to "PhCH number 2", and so on until the pth to "PhCH number p".

8.6.7 Measurement information elements

8.6.7.1 Measurement validity

If the IE "measurement validity" for a given measurement has been assigned to value "release", the UE shall delete the measurement associated with the variable MEASUREMENT IDENTITY after the UE makes a transition to a new state.

If the IE "measurement validity" for this measurement has been assigned to value "resume", the UE shall save the measurement associated with the variable MEASUREMENT IDENTITY. The IE "UE state" defines the scope of resuming the measurement.

If the "UE state" is defined as "all states", the UE shall continue the measurement after making a transition to a new state. This scope is assigned only for traffic volume type measurements.

If the "UE state" is defined as "all states except CELL_DCH", the UE shall store the measurement to be resumed after a subsequent transition from CELL_DCH state to any of the other states in connected mode. This scope is assigned only for traffic volume type measurements.

If the "UE state" is defined as "CELL_DCH", the UE shall store the measurement to be resumed after a subsequent transition to CELL_DCH state. After cell re-selection, the UE shall delete any ongoing measurement intra-frequency or inter-frequency and inter-system type measurement associated with the variable MEASUREMENT IDENTITY. Other measurement types shall, however, be continued regardless of cell reselection.

8.6.7.2 Filter coefficient

If the IE "Filter coefficient" is received the UE shall apply filtering of the measurements for that measurement quantity according to the formula below. This filtering shall be performed by the UE before UE event evaluation. The UE shall also filter the measurements reported in the IE "Measured results" or the IE "Measurement results on RACH". The filtering shall not be performed for cell-reselection in connected or idle mode.

The filtering shall be performed according to the following formula.

$$F_n = (1 - a) \cdot F_{n-1} + a \cdot M_n$$

The variables in the formula are defined as follows:

F_n is the updated filtered measurement result

F_{n-1} is the old filtered measurement result

M_n is the latest received measurement result from physical layer measurements, the unit used for M_n is the same unit as the reported unit in the MEASUREMENT REPORT message or the unit used in the event evaluation.

$a = 1/2(k/2)$, where k is the parameter received in the IE "Filter coefficient".

NOTE: if a is set to 1 that will mean no layer 3 filtering.

In order to initialise the averaging filter, F_0 is set to M_1 when the first measurement result from the physical layer measurement is received.

The physical layer measurement results are sampled once every measurement period. The measurement period and the accuracy for a certain measurement is defined in 3GPP TS 25.133.

8.6.7.3 Intra-frequency/Inter-frequency/Inter-system cell info list

If one of these IEs is received, and "Removed ***** cells" or/and "New ***** cells" is present in the received IE, UE shall update measurement objects for that measurement accordingly.

If one of these IEs is included, but neither "Removed ***** cells" nor "New ***** cells" is included, UE shall not change the information on that measurement object. (This case is applied only when Measurement Command = "Modify".)

If one of these IEs is not received when IE is absent, UE shall re-order same measurement type by measurement ID in ascending order, and use the preceding ID's measurement object information. (For example, suppose UE is assigned 3 measurement IDs (suppose they were ID10, 11, and 15) for intra-frequency measurement, and UE did not receive "Intra-frequency cell info" for Measurement ID 15. When performing the measurement assigned with 15, UE shall use the measurement object information associated with Measurement ID 11).

8.6.7.4 Inter-system measurement quantity

If the IE "Inter-system measurement quantity" is received and CHOICE system is GSM, the UE shall check the parameter "BSIC verification required".

If BSIC verification required is set to "required" the UE shall only report measurement quantities for GSM cells with a "verified" BSIC.

If BSIC verification required is set to "not required" the UE shall report measurement quantities for GSM cells both with "verified" and "non-verified" BSIC.

The requirements for a cell to be considered "verified" or "non-verified" can be found in TS 25.133.

8.6.7.5 Cell Reporting Quantities

If the IE "Cell Reporting Quantities" is received by the UE, the UE shall store the content of the IE "Cell Reporting Quantities" to the variable MEASUREMENT_IDENTITY.

The UE shall include measured results in MEASUREMENT REPORT as specified in the IE "Cell Reporting Quantity", except for the following case:

If the IE "Cell Identity" is set to TRUE, the UE shall:

- in CELL_FACH state:
 - report the IE "Cell Identity" that is given in System Information Block type 4 (or type 3, if System Information Block type4 is not being broadcast).
- in CELL_DCH state:
 - treat the IE as if the IE "Cell Identity" is set to FALSE.

8.6.7.6 Reporting Cell Status

If the IE "Reporting Cell Status" is received, the UE shall set the IE "Measured Results" in MEASUREMENT REPORT as follows:

- for intra-frequency measurement and inter-frequency measurement:
 - include the IE "Cell Measured Results" for cells that satisfy the condition (such as "within active set cells") specified in "Reporting Cell Status", in descending order by the measurement quantity.
 - the maximum number of the IE "Cell Measured Results" to be included in the IE "Measured Results" is the number specified in "Reporting Cell Status".

If the IE "Reporting Cell Status" is not received for intra-frequency or inter-frequency measurement, the UE shall:

- exclude the IE "cell measured results" for any cell in MEASUREMENT REPORT.

8.6.8 Other information elements

8.6.8.1 RAB NAS Synchronization Indicator

If the IE "NAS Synchronization Indicator" is present in a message, the UE shall forward the content to the non-access stratum entity for the associated RAB.

10 Message and information element functional definition and content

10.1 General

The function of each Radio Resource Control message together with message contents in the form of a list of information elements is defined in subclause 10.2.

Functional definitions of the information elements are then described in subclause 10.3.

Information elements are marked as either MP- Mandatory present, MD - Mandatory with default value, OP - Optional, CV - Conditional on value or CH -Conditional on history (see Table 10.1 with information extracted from [14]).

Table 10.1: Meaning of abbreviations used in RRC messages and information elements

Abbreviation	Meaning
MP	Mandatory present A value for that information is always needed, and no information is provided about a particular default value. If ever the transfer syntax allows absence (e.g., due to extension), then absence leads to an error diagnosis.
MD	Mandatory with default value A value for that information is always needed, and a particular default value is mentioned (in the 'Semantical information' column). This opens the possibility for the transfer syntax to use absence or a special pattern to encode the default value.
CV	Conditional on value A value for that information is needed (presence needed) or unacceptable (absence needed) when some conditions are met that can be evaluated on the sole basis of the content of the message. If conditions for presence needed are specified, the transfer syntax must allow for the presence of the information. If the transfer syntax allows absence, absence when the conditions for presence are met leads to an error diagnosis. If conditions for absence needed are specified, the transfer syntax must allow to encode the absence. If the information is present and the conditions for absence are met, an error is diagnosed. When neither conditions for presence or absence are met, the information is treated as optional, as described for 'OP'.
CH	Conditional on history A value for that information is needed (presence needed) or unacceptable (absence needed) when some conditions are met that must be evaluated on the basis of information obtained in the past (e.g., from messages received in the past from the other party). If conditions for presence needed are specified, the transfer syntax must allow for the presence of the information. If the transfer syntax allows absence, absence when the conditions for presence are met leads to an error diagnosis. If conditions for absence needed are specified, the transfer syntax must allow to encode the absence. If the information is present and the conditions for absence are met, an error is diagnosed. When neither conditions for presence or absence are met, the information is treated as optional, as described for 'OP'.
OP	Optional

Abbreviation	Meaning
	The presence or absence is significant and modifies the behaviour of the receiver. However whether the information is present or not does not lead to an error diagnosis.

10.1.1 Protocol extensions

In this specification, two kind of protocol extensions are distinguished:

- extension of an information element with additional values or choices;
- extension of a message with additional information elements.

This standard fully specifies the behaviour of the UE, conforming to this revision of the standard, upon receiving a not comprehended future extension. The details of this error handling behaviour are provided in clause 16.

NOTE: By avoiding the need for partial decoding (skipping uncomprehended IEs to continue decoding the remainder of the message), the RRC protocol extension mechanism also avoids the overhead of length determinants for extensions.

10.1.1.1 Extension of an information element with additional values or choices

In future releases of this protocol, some of the value ranges and choices may be extended. For these value ranges and choices, one or more additional values are reserved. The size of the encoded information element shall not depend on whether or not the values reserved for extension are used. Information elements applicable to choices reserved for future releases of the protocol, shall be added to the end of the message.

For each of the values and choices reserved for future extension, the behaviour of a UE conforming to this revision of the standard is defined within the message and information element specifications provided in subclause 10.1 and 10.2. The UE may either apply a defined value, ignore the information element and/ or reject the request entire message. Which action applies is indicated within the "semantics" column of the tables specifying the messages and information elements as the "criticality" ("default", "ignore" or "reject").

10.1.1.2 Extension of a message with additional information elements

In future releases of this protocol, RRC messages may be extended with new information elements. These additional information elements shall always be included at the end of the message.

UTRAN is able to control the behaviour of a UE receiving a message extended with a not comprehended additional information element by indicating for each extension the "criticality" which may be "ignore" or "reject". Therefore UTRAN indicates the criticality for extensions provided in all messages it sends towards the UE, with the exception of broadcast messages. In the direction from UE to UTRAN, not criticality information is included for protocol extensions added at the end of a message. This is shown in the following table. Furthermore, the table indicates at which level extensions are included for the SYSTEM INFORMATION message.

Type	Message
Extensions and criticality	ACTIVE SET UPDATE 10.2.1 CELL UPDATE CONFIRM 10.2.5 DOWNLINK DIRECT TRANSFER 10.2.8 DOWNLINK OUTER LOOP CONTROL 10.2.9 HANDOVER TO UTRAN COMMAND 10.2.10 INTER SYSTEM HANDOVER COMMAND 10.2.13 MEASUREMENT CONTROL 10.2.15 PAGING TYPE 1 10.2.18 PAGING TYPE 2 10.2.19 PHYSICAL CHANNEL RECONFIGURATION 10.2.20 PHYSICAL SHARED CHANNEL ALLOCATION 10.2.23 RADIO BEARER RECONFIGURATION 10.2.25 RADIO BEARER RELEASE 10.2.28 RADIO BEARER SETUP 10.2.31 RRC CONNECTION RE-ESTABLISHMENT 10.2.34 RRC CONNECTION REJECT 10.2.37 RRC CONNECTION RELEASE 10.2.38 RRC CONNECTION SETUP 10.2.41 SECURITY MODE COMMAND 10.2.44 SIGNALLING CONNECTION RELEASE 10.2.47 SIGNALLING CONNECTION RELEASE REQUEST 10.2.48 TRANSPORT CHANNEL RECONFIGURATION 10.2.51 TRANSPORT FORMAT COMBINATION CONTROL 10.2.54 UE CAPABILITY ENQUIRY 10.2.56 UE CAPABILITY INFORMATION CONFIRM 10.2.58 UPLINK PHYSICAL CHANNEL CONTROL 10.2.60 URA UPDATE CONFIRM 10.2.62 UTRAN MOBILITY INFORMATION 10.2.63
Extensions	ACTIVE SET UPDATE COMPLETE 10.2.2 ACTIVE SET UPDATE FAILURE 10.2.3 CELL UPDATE 10.2.4 INITIAL DIRECT TRANSFER 10.2.12 INTER SYSTEM HANDOVER FAILURE 10.2.14 MEASUREMENT CONTROL FAILURE 10.2.16 MEASUREMENT REPORT 10.2.17 PHYSICAL CHANNEL RECONFIGURATION COMPLETE 10.2.21 PHYSICAL CHANNEL RECONFIGURATION FAILURE 10.2.22 PUSCH CAPACITY REQUEST 10.2.24 RADIO BEARER RECONFIGURATION COMPLETE 10.2.26 RADIO BEARER RECONFIGURATION FAILURE 10.2.27 RADIO BEARER RELEASE COMPLETE 10.2.29 RADIO BEARER RELEASE FAILURE 10.2.30 RADIO BEARER SETUP COMPLETE 10.2.32 RADIO BEARER SETUP FAILURE 10.2.33 RRC CONNECTION RE-ESTABLISHMENT COMPLETE 10.2.35 RRC CONNECTION RE-ESTABLISHMENT REQUEST 10.2.36 RRC CONNECTION RE-ESTABLISHMENT REJECT 10.2.37 RRC CONNECTION RELEASE COMPLETE 10.2.39 RRC CONNECTION REQUEST 10.2.40 RRC CONNECTION SETUP COMPLETE 10.2.42 RRC STATUS 10.2.43 SECURITY MODE COMPLETE 10.2.45 SECURITY MODE FAILURE 10.2.46 Master Information Block 10.2.49.8.1 System Information Block type 1 to System Information Block type 16 10.2.49.8.2 to 10.2.49.8.18 SYSTEM INFORMATION CHANGE INDICATION 10.2.50 TRANSPORT CHANNEL RECONFIGURATION COMPLETE 10.2.52 TRANSPORT CHANNEL RECONFIGURATION FAILURE 10.2.53 TRANSPORT FORMAT COMBINATION CONTROL FAILURE 10.2.55 UE CAPABILITY INFORMATION 10.2.57 UPLINK DIRECT TRANSFER 10.2.59 URA UPDATE 10.2.61 UTRAN MOBILITY INFORMATION CONFIRM 10.2.64 UTRAN MOBILITY INFORMATION FAILURE 10.2.65
None	SYSTEM INFORMATION 10.2.49 First Segment 10.2.49.1

Type	Message
	Subsequent or last Segment 10.2.49.3 Complete SIB 10.2.49.5 SIB content 10.2.49.8.1

NOTE 1: For the SYSTEM INFORMATION message protocol extensions are only possible at the level of system information blocks. If extension is needed at the level of SYSTEM INFORMATION, another message should be defined.

The "Extensions and criticality" may include both critical and non-critical extensions. Within the encoded message, the critical extensions shall always appear before non-critical extensions.

NOTE 2: The above implies that a UE may stop decoding upon the first not comprehended IE it encounters.

The UE shall comprehend all information elements within a message upto the revision of the protocol it supports for the concerned message.

10.2 Radio Resource Control messages

In connected mode, RB 0, 1, 2, 3 and optionally 4 are available for usage by RRC messages using RLC-TM, RLC-UM and RLC-AM on the DCCH and CCCH. The UE and UTRAN shall select radio bearer for RRC messages using RLC-TM, RLC-UM or RLC-AM on the DCCH and CCCH, according to the following:

- RB 0 shall be used for all messages sent on the CCCH.
- RB 1 shall be used for all messages sent on the DCCH, when using RLC unacknowledged mode (RLC-UM).
- RB 2 shall be used for all messages sent on the DCCH, when using RLC acknowledged mode (RLC-AM), except for the INITIAL DIRECT TRANSFER, DOWNLINK DIRECT TRANSFER and UPLINK DIRECT TRANSFER messages.
- RB 3 or 4 shall be used by the INITIAL DIRECT TRANSFER (RB 3), DOWNLINK DIRECT TRANSFER and UPLINK DIRECT TRANSFER messages sent on the DCCH in RLC acknowledged mode (RLC-AM), as specified in subclause 8.1.8., 8.1.9 and 8.1.10.
- For RRC messages on the DCCH using RLC transparent mode (RLC-TM), the transparent signalling DCCH shall be used.
- RRC messages on the SHCCH are mapped either on RACH or on the USCH with the lowest assigned Transport Channel Id in the uplink and either on FACH or on the DSCH with the lowest assigned Transport Channel Id using RLC-TM.
These messages are only specified for TDD mode.

When an RRC message is transmitted in DL on CCCH or SHCCH using RLC UM, RRC should indicate to RLC that a special RLC length indicator should be used [16]. The UE shall assume that this indication has been given. The special length indicator indicates that an RLC SDU begins in the beginning of an RLC PDU.

10.2.1 ACTIVE SET UPDATE

NOTE: Only for FDD.

This message is used by UTRAN to add, replace or delete radio links in the active set of the UE.

RLC-SAP: AM

Logical channel: DCCH

Direction: UTRAN → UE

Information Element/Group name	Need	Multi	Type and reference	Semantics description
Message Type	MP		Message Type	
UE information elements				
<u>RRC transaction identifier</u>	<u>MP</u>		<u>RRC transaction identifier</u> 10.3.3.34a	
Integrity check info	CH		Integrity check info 10.3.3.14	
Integrity protection mode info	OP		Integrity protection mode info 10.3.3.17	
Ciphering mode info	OP		Ciphering mode info 10.3.3.5	
Activation time	MD		Activation time 10.3.3.1	Default value is "now".
New U-RNTI	OP		U-RNTI 10.3.3.45	
CN information elements				
CN Information info	OP		CN Information info 10.3.1.3	
RB information elements				
RB with PDCP information list	OP	1 to <maxRBall RABs>		This IE is needed for each RB having PDCP in the case of lossless SRNS relocation
>RB with PDCP information	MP		RB with PDCP information 10.3.4.22	
Phy CH information elements				
Uplink radio resources				
Maximum allowed UL TX power	MD		Maximum allowed UL TX power 10.3.6.38	Default value is the existing "maximum UL TX power."
Downlink radio resources				
Radio link addition information	OP	1 to <maxRL-1>		Radio link addition information required for each RL to add
>Radio link addition information	MP		Radio link addition information 10.3.6.67	
Radio link removal information	OP	1 to <maxRL-1>		Radio link removal information required for each RL to remove
> Radio link removal information	MP		Radio link removal information 10.3.6.68	
TX Diversity Mode	MD		TX Diversity Mode 10.3.6.84	Default value is the existing TX diversity mode.
SSDT information	OP		SSDT information	

Information Element/Group name	Need	Multi	Type and reference	Semantics description
			10.3.6.76	

10.2.2 ACTIVE SET UPDATE COMPLETE

NOTE: For FDD only.

This message is sent by UE when active set update has been completed.

RLC-SAP: AM

Logical channel: DCCH

Direction: UE→UTRAN

Information Element/Group name	Need	Multi	Type and reference	Semantics description
Message Type	MP		Message Type	
UE information elements				
<u>RRC transaction identifier</u>	<u>MP</u>		<u>RRC transaction identifier</u> 10.3.3.34a	
Integrity check info	CH		Integrity check info 10.3.3.14	
Uplink integrity protection activation info	OP		Integrity protection activation info 10.3.3.15	
RB Information elements				
Radio bearer uplink ciphering activation time info	OP		RB activation time info 10.3.4.13	
RB with PDCP information list	OP	1 to <maxRBall RABs>		This IE is needed for each RB having PDCP in the case of lossless SRNS relocation
>RB with PDCP information	MP		RB with PDCP information 10.3.4.22	

10.2.3 ACTIVE SET UPDATE FAILURE

NOTE: Only for FDD.

This message is sent by UE if the update of the active set has failed, e.g. because the radio link is not a part of the active set.

RLC-SAP: AM

Logical channel: DCCH

Direction: UE→UTRAN

Information Element/Group name	Need	Multi	Type and reference	Semantics description
Message Type	MP		Message Type	
UE information elements				
<u>RRC transaction identifier</u>	<u>MP</u>		<u>RRC transaction identifier</u> 10.3.3.34a	
Integrity check info	CH		Integrity check info 10.3.3.14	
Failure cause	MP		Failure cause and error information 10.3.3.12	

10.2.4 CELL UPDATE

This message is used by the UE to initiate a cell update procedure.

RLC-SAP: TM

Logical channel: CCCH

Direction: UE→UTRAN

Information Element/Group name	Need	Multi	Type and reference	Semantics description
Message Type	MP		Message Type	
UE information elements				
U-RNTI	MP		U-RNTI 10.3.3.45	
<u>RRC transaction identifier</u>	<u>CV-Failure</u>		<u>RRC transaction identifier</u> 10.3.3.34a	
Integrity check info	CH		Integrity check info 10.3.3.14	
START list	MP	1 to <maxCNdomains>		START [TS 33.102] values for all CN domains.
>CN domain identity	MP		CN domain identity 10.3.1.1	
>START	MP		START 10.3.3.36	START value to be used in this CN domain.
AM_RLC error indication(for c-plane)	MP		Boolean	TRUE indicates AM_RLC unrecoverable error occurred on c-plane in the UE
AM_RLC error indication(for u-plane)	MP		Boolean	TRUE indicates AM_RLC unrecoverable error occurred on u-plane in the UE
Cell update cause	MP		Cell update cause 10.3.3.3	
<u>Failure cause</u>	<u>OP</u>		<u>Failure cause and error information</u> 10.3.3.12	
Protocol error indicator	MD		Protocol error indicator 10.3.3.27	Default value is FALSE
Measurement information elements				
Measured results on RACH	OP		Measured results on RACH 10.3.7.70	
Other information elements				
Protocol error information	CV-ProtErr		Protocol error information 10.3.8.10	

Condition	Explanation
<u>FailureProtErr</u>	If the IE "Protocol error indicator <u>Failure cause</u> " has the value "TRUE" is present

10.2.5 CELL UPDATE CONFIRM

This message confirms the cell update procedure and can be used to reallocate new RNTI information for the UE valid in the new cell.

RLC-SAP: UM

Logical channel: CCCH or DCCH

Direction: UTRAN→UE

Information Element/Group name	Need	Multi	Type and reference	Semantics description
Message Type	MP		Message Type	
UE Information Elements				
U-RNTI	CV-CCCH		U-RNTI 10.3.3.45	
<u>RRC transaction identifier</u>	<u>MP</u>		<u>RRC transaction identifier</u> 10.3.3.34a	
Integrity check info	CH		Integrity check info 10.3.3.14	
Integrity protection mode info	OP		Integrity protection mode info 10.3.3.17	
Ciphering mode info	OP		Ciphering mode info 10.3.3.5	
<u>Activation time</u>	<u>MD</u>		<u>Activation time</u> 10.3.3.1	<u>Default value is "now"</u>
New U-RNTI	OP		U-RNTI 10.3.3.45	
New C-RNTI	OP		C-RNTI 10.3.3.8	
<u>DRX Indicator</u> <u>RRC State Indicator</u>	MP		<u>DRX Indicator</u> <u>RR C State Indicator</u> 10.3.3.10	
UTRAN DRX cycle length coefficient	MD		UTRAN DRX cycle length coefficient 10.3.3.47	Default value is the existing DRX cycle length coefficient
RLC reset indicator (for C-plane)	MD		RLC reset indicator 10.3.3.34	
RLC reset indicator (for U-plane)	MD		RLC reset indicator 10.3.3.34	
CN Information Elements				
CN Information info	OP		CN Information info 10.3.1.3	
UTRAN Information Elements				
URA identity	OP		URA identity 10.3.2.6	
RB information elements				
RB with PDCP information list	OP	1 to <maxRBall RABs>		This IE is needed for each RB having PDCP in the case of lossless SRNS relocation
>RB with PDCP information	MP		RB with PDCP information	

Information Element/Group name	Need	Multi	Type and reference	Semantics description
			10.3.4.22	
PhyCH information elements				
Frequency info	MD		Frequency info 10.3.6.35	Default value is the existing value of frequency information
Uplink radio resources				
Maximum allowed UL TX power	MD		Maximum allowed UL TX power 10.3.6.38	Default value is the existing maximum UL TX power
PRACH Info (for RACH)	OP		PRACH Info (for RACH) 10.3.6.54	
Downlink radio resources				
Downlink information for one radio link	OP		Downlink information for each radio link 10.3.6.26	

Condition	Explanation
CCCH	This IE is only sent when CCCH is used and ciphering is not required

10.2.6 COUNTER CHECK

This message is used by the UTRAN to indicate the current COUNT-C MSB values associated to each radio bearer utilising UM or AM RLC mode and to request the UE to compare these to its COUNT-C MSB values and to report the comparison results to UTRAN.

RLC-SAP: AM

Logical channel: DCCH

Direction: UTRAN→UE

Information Element/Group name	Presence	Multi	IE type and reference	Semantics description
Message Type	MP			
UE information elements				
<u>RRC transaction identifier</u>	<u>MP</u>		<u>RRC transaction identifier</u> 10.3.3.34a	
Integrity check info	MP		Integrity check info 10.3.3.14	
RB information elements				
RB COUNT-C MSB information	MP	1 to < maxRBallR ABs >		For each RB (excluding SRBs) using UM or AM RLC.
>RB COUNT-C MSB information	MP		RB COUNT-C MSB information 10.3.4.14	

10.2.7 COUNTER CHECK RESPONSE

This message is used by the UE to respond to a COUNTER CHECK message.

RLC-SAP: AM

Logical channel: DCCH

Direction: UE→UTRAN

Information Element/Group name	Presence	Multi	IE type and reference	Semantics description
Message Type	MP			
UE information elements				
<u>RRC transaction identifier</u>	<u>MP</u>		<u>RRC transaction identifier</u> 10.3.3.34a	
Integrity check info	MP		Integrity check info 10.3.3.14	
RB information elements				
RB COUNT-C information	OP	1 to < maxRBAllR ABs >		For each RB (excluding SRBs) using UM or AM RLC whose COUNT-C MSB values did not match with the values received from the UTRAN.
>RB COUNT-C information	MP		RB COUNT-C information 10.3.4.15	

10.2.8 DOWNLINK DIRECT TRANSFER

This message is sent by UTRAN to transfer higher layer messages.

RLC-SAP: AM

Logical channel: DCCH

Direction: UTRAN -> UE

Information Element/Group name	Need	Multi	Type and reference	Semantics description
Message Type	MP		Message Type	
UE information elements				
<u>RRC transaction identifier</u>	<u>MP</u>		<u>RRC transaction identifier</u> 10.3.3.34a	
Integrity check info	CH		Integrity check info 10.3.3.14	
CN information elements				
CN Domain Identity	MP		Core Network Domain Identity 10.3.1.1	
NAS message	MP		NAS message 10.3.1.8	

10.2.9 DOWNLINK OUTER LOOP CONTROL

This message is sent to suspend and resume the setting of the SIR target value for downlink outer loop power control.

RLC-SAP: AM or UM

Logical channel: DCCH

Direction: UTRAN→UE

Information Element/Group name	Need	Multi	Type and reference	Semantics description
Message Type	MP		Message Type	
UE information elements				
<u>RRC transaction identifier</u>	<u>MP</u>		<u>RRC transaction identifier</u> 10.3.3.34a	
Integrity check info	CH		Integrity check info 10.3.3.14	
PhyCH information elements				
Downlink Outer Loop Control	MP		Downlink Outer Loop Control 10.3.6.28	Indicates whether the UE is allowed or not to increase its SIR-target value above its current value
Downlink DPCH power control information	MD		Downlink DPCH power control information 10.3.6.22	Default value is the existing "Downlink DPCH power control information"

10.2.10 HANDOVER TO UTRAN COMMAND

This message is sent to the UE via other system to make a handover to UTRAN.

RLC-SAP: N/A (Sent through a different RAT)

Logical channel: N/A (Sent through a different RAT)

Direction: UTRAN → UE

Information Element/Group name	Need	Multi	Type and reference	Semantics description
New U-RNTI	MP		U-RNTI Short 10.3.3.46	
Activation time	MD		Activation time 10.3.3.1	Default value is "now"
Ciphering algorithm	OP		Ciphering algorithm 10.3.3.4	
RAB info	MP		RAB info short 10.3.4.9	One RAB is established
CHOICE specification mode	MP			
>Complete specification				
UE information elements				
>>Re-establishment timer	MP		Re- establishe ment timer 10.3.3.29	
RB information elements				
>>Signalling RB information to setup list	MP	1 to <maxSRBs etup>		For each signalling radio bearer established
>>>Signalling RB information to setup	MP		Signalling RB information to setup 10.3.4.24	
>>RB information to setup list	MP	1 to <maxRBpe rRAB>		
>>>RB information to setup	MP		RB information to setup 10.3.4.20	
Uplink transport channels				
>>UL Transport channel information common for all transport channels	MP		UL Transport channel information common for all transport channels 10.3.5.24	
>>Added or Reconfigured TrCH information	MP	1 to <maxTrCH >		
>>>Added or Reconfigured UL TrCH information	MP		Added or Reconfigure d UL TrCH information 10.3.5.2	
Downlink transport channels				
>>DL Transport channel information common for all transport channels	MP		DL Transport channel information common for all transport channels 10.3.5.6	
>>Added or Reconfigured TrCH	MP	1 to		

Information Element/Group name	Need	Multi	Type and reference	Semantics description
information		<maxTrCH >		
>>>Added or Reconfigured DL TrCH information	MP		Added or Reconfigured DL TrCH information 10.3.5.1	
Uplink radio resources				
>>Uplink DPCH info	MP		Uplink DPCH info 10.3.6.86	
>>CPCH SET Info	OP		CPCH SET Info 10.3.6.12	
Downlink radio resources				
>>CHOICE mode	MP			
>>>FDD				
>>>>Downlink PDSCH information	OP		Downlink PDSCH information 10.3.6.29	
>>>TDD				(no data)
>>Downlink information common for all radio links	MP		Downlink information common for all radio links 10.3.6.23	
>>Downlink information per radio link	MP	1 to <maxRL>		
>>>Downlink information for each radio link	MP		Downlink information for each radio link 10.3.6.26	
>Preconfiguration				
>>Predefined configuration identity	MP		Predefined configuration identity 10.3.4.5	
>>Uplink DPCH info	MP		Uplink DPCH info Post 10.3.6.87	
Downlink radio resources				
>>CHOICE mode				
>>>FDD				
>>>>Downlink information common for all radio links			Downlink information common for all radio links Post 10.3.6.24	
>>>TDD				(no data)
>>Downlink information per radio link	MP	1 to <maxRL>		Send downlink information for each radio link to be set-up. In TDD MaxRL is 1.
>>>Downlink information for each radio link	MP		Downlink information for each radio link Post 10.3.6.27	
Frequency info	MP		Frequency info 10.3.6.35	

Information Element/Group name	Need	Multi	Type and reference	Semantics description
Maximum allowed UL TX power	MP		Maximum allowed UL TX power 10.3.6.38	
CHOICE mode	MP			
>FDD				(no data)
>TDD				
>>Primary CCPCH Tx Power	MP		Primary CCPCH Tx Power 10.3.6.58	

10.2.11 HANDOVER TO UTRAN COMPLETE

This message is sent by the UE when a handover to UTRAN has been completed.

RLC-SAP: AM

Logical channel: DCCH

Direction: UE → UTRAN

Information Element/Group name	Need	Multi	Type and reference	Semantics description
Message Type	MP		Message Type	
START list	CH	1 to <maxCNdo mains>		START [TS 33.102] values for all CN domains. The IE is mandatory if it has not been transferred prior to the handover.
>CN domain identity	MP		CN domain identity 10.3.1.1	
>START	MP		START 10.3.3.36	

10.2.12 INITIAL DIRECT TRANSFER

This message is used to initiate a signalling connection or to establish a new signalling flow based on indication from the upper layers, and to transfer NAS messages.

RLC-SAP: AM

Logical channel: DCCH

Direction: UE -> UTRAN

Information Element/Group name	Need	Multi	Type and reference	Semantics description
Message Type	MP		Message Type	
UE information elements				
Integrity check info	CH		Integrity check info 10.3.3.14	
CN information elements				
Service Descriptor	MP		Service Descriptor 10.3.1.17	
Flow Identifier	MP		Flow Identifier 10.3.1.4	Allocated by UE for a particular flow
CN domain identity	MP		CN domain identity 10.3.1.1	
NAS message	MP		NAS message 10.3.1.8	
Measurement information elements				
Measured results on RACH	OP		Measured results on RACH 10.3.7.70	

10.2.13 INTER-SYSTEM HANDOVER COMMAND

This message is used for handover from UMTS to another system e.g. GSM. One or several messages from the other system can be included in the Inter-System message information element in this message. These messages are structured and coded according to that systems specification.

RLC-SAP: AM

Logical channel: DCCH

Direction: UTRAN→UE

Information Element/Group name	Need	Multi	Type and reference	Semantics description
Message Type	MP		Message Type	
UE information elements				
RRC transaction identifier	MP		RRC transaction identifier 10.3.3.34a	
Integrity check info	CH		Integrity check info 10.3.3.14	
Activation time	MD		Activation time 10.3.3.1	Default value is "now"
RB information elements				
RAB info	OP		RAB info 10.3.4.8	Remaining radio access bearer if any
Other information elements				
Inter-System message	MP		Inter-System message 10.3.8.6	

10.2.14 INTER-SYSTEM HANDOVER FAILURE

This message is sent on the RRC connection used before the Inter-System Handover was executed. The message indicates that the UE has failed to seize the new channel in the other system.

RLC-SAP: AM

Logical channel: DCCH

Direction: UE→UTRAN

Information Element/Group name	Need	Multi	Type and reference	Semantics description
Message Type	MP		Message Type	
UE information elements				
<u>RRC transaction identifier</u>	<u>MP</u>		<u>RRC transaction identifier</u> 10.3.3.34a	
Integrity check info	CH		Integrity check info 10.3.3.14	
Other information elements				
Inter-System handover failure	OP		Inter-System handover failure 10.3.8.5	

10.2.15 MEASUREMENT CONTROL

This message is sent by UTRAN to setup, modify or release a measurement in the UE.

RLC-SAP: AM

Logical channel: DCCH

Direction: UTRAN→UE

Information Element/Group name	Need	Multi	Type and reference	Semantics description
Message Type	MP		Message Type	
UE information elements				
<u>RRC transaction identifier</u>	<u>MP</u>		<u>RRC transaction identifier</u> 10.3.3.34a	
Integrity check info	CH		Integrity check info 10.3.3.14	
Measurement Information elements				
Measurement Identity Number	MP		Measurement Identity Number 10.3.7.73	
Measurement Command	MP		Measurement Command 10.3.7.71	
Measurement Reporting Mode	OP		Measurement Reporting Mode 10.3.7.74	
Additional measurements list	OP		Additional measurements list 10.3.7.1	
CHOICE Measurement type	CV command			
>Intra-frequency measurement			Intra-frequency measurement 10.3.7.36	
>Inter-frequency measurement			Inter-frequency measurement 10.3.7.16	
>Inter-system measurement			Inter-system measurement 10.3.7.27	
>LCS measurement			LCS measurement 10.3.7.57	
>Traffic Volume measurement			Traffic Volume measurement 10.3.7.93	
>Quality measurement			Quality measurement 10.3.7.81	
>UE internal measurement			UE internal measurement 10.3.7.102	
Physical channel information elements				
DPCH compressed mode status info	OP		DPCH compressed mode status info 10.3.6.33	

Condition	Explanation
Command	The IE is mandatory if the "Measurement command" IE is set to "Setup", optional if the "Measurement command" IE is set to "modify", otherwise the IE is not needed.

10.2.16 MEASUREMENT CONTROL FAILURE

This message is sent by UE, if it can not initiate a measurement as instructed by UTRAN.

RLC-SAP: AM

Logical channel: DCCH

Direction: UE→UTRAN

Information Element/Group name	Need	Multi	Type and reference	Semantics description
Message Type	MP		Message Type	
UE information elements				
<u>RRC transaction identifier</u>	<u>MP</u>		<u>RRC transaction identifier</u> 10.3.3.34a	
Integrity check info	CH		Integrity check info 10.3.3.14	
Failure cause	MP		Failure cause and error information 10.3.3.12	

10.2.17 MEASUREMENT REPORT

This message is used by UE to transfer measurement results to the UTRAN.

RLC-SAP: AM or UM

Logical channel: DCCH

Direction: UE→UTRAN

Information Element/Group name	Need	Multi	Type and reference	Semantics description
Message Type	MP		Message Type	
UE information elements				
Integrity check info	CH		Integrity check info 10.3.3.14	
Measurement Information Elements				
Measurement identity number	MP		Measurement identity number 10.3.7.73	
Measured Results	OP		Measured Results 10.3.7.69	
Additional Measured results	OP	1 to <maxAdditionalMeas>		
>Measured Results	MP		Measured Results 10.3.7.69	
Event results	OP		Event results 10.3.7.7	

10.2.18 PAGING TYPE 1

This message is used to send information on the paging channel. One or several UEs, in idle or connected mode, can be paged in one message, which also can contain other information.

RLC-SAP: TM

Logical channel: PCCH

Direction: UTRAN → UE

Information Element/Group name	Need	Multi	Type and reference	Semantics description
Message Type	MP		Message Type	
UE Information elements				
Paging record list	OP	1 to <maxPage 1>		
>Paging record	MP		Paging record 10.3.3.23	
Other information elements				
BCCH modification info	OP		BCCH modification info 10.3.8.1	

If the encoded message does not fill a transport block, the RRC layer shall add padding according to subclause 12.1.

10.2.19 PAGING TYPE 2

This message is used to page an UE in connected mode, when using the DCCH for CN originated paging.

RLC-SAP: AM

Logical channel: DCCH

Direction: UTRAN → UE

Information Element/Group name	Need	Multi	Type and reference	Semantics description
Message Type	MP		Message Type	
UE information elements				
<u>RRC transaction identifier</u>	<u>MP</u>		<u>RRC transaction identifier</u> 10.3.3.34a	
Integrity check info	CH		Integrity check info 10.3.3.14	
Paging cause	MP		Paging cause 10.3.3.22	
CN Information elements				
CN domain identity	MP		CN domain identity 10.3.1.1	
Paging Record Type Identifier	MP		Paging Record Type Identifier 10.3.1.10	

10.2.20 PHYSICAL CHANNEL RECONFIGURATION

This message is used by UTRAN to assign, replace or release a set of physical channels used by a UE.

RLC-SAP: AM or UM

Logical channel: DCCH

Direction: UTRAN → UE

Information Element/Group name	Need	Multi	Type and reference	Semantics description
Message Type	MP		Message Type	
UE Information Elements				
<u>RRC transaction identifier</u>	<u>MP</u>		<u>RRC transaction identifier</u> 10.3.3.34a	
Integrity check info	CH		Integrity check info 10.3.3.1415	
Integrity protection mode info	OP		Integrity protection mode info 10.3.3.17	
Ciphering mode info	OP		Ciphering mode info 10.3.3.5	
Activation time	MD		Activation time 10.3.3.1	Default value is "now"
New U-RNTI	OP		U-RNTI 10.3.3.45	
New C-RNTI	OP		C-RNTI 10.3.3.8	
<u>DRX Indicator</u> <u>RRC State Indicator</u>	<u>MP</u>		<u>DRX Indicator</u> <u>RR C State Indicator</u> 10.3.3.10	
UTRAN DRX cycle length coefficient	MD		UTRAN DRX cycle length coefficient 10.3.3.47	Default value is the existing value of UTRAN DRX cycle length coefficient
CN Information Elements				
CN Information info	OP		CN Information info 10.3.1.3	
UTRAN mobility information elements				
URA identity	OP		URA identity 10.3.2.6	
RB information elements				
RB with PDCP information list	OP	1 to <maxRBall RABs>		This IE is needed for each RB having PDCP in the case of lossless SRNS relocation
>RB with PDCP information	MP		RB with PDCP information 10.3.4.22	
PhyCH information elements				
Frequency info	MD		Frequency info 10.3.6.35	Default value is the existing value of frequency information
Uplink radio resources				
Maximum allowed UL TX power	MD		Maximum allowed UL	Default value is the existing value of the maximum allowed

Information Element/Group name	Need	Multi	Type and reference	Semantics description
			TX power 10.3.6.38	UL TX power
CHOICE channel requirement	OP			At least one criticality=reject spare value needed for future extension
>Uplink DPCH info			Uplink DPCH info 10.3.6.86	
>PRACH Info (for RACH)			PRACH Info (for RACH) 10.3.6.54	
>CPCH SET Info			CPCH SET Info 10.3.6.12	
>CPCH set ID			CPCH set ID 10.3.5.3	
Downlink radio resources				
CHOICE mode	MP			
>FDD				
>>Downlink PDSCH information	OP		Downlink PDSCH information 10.3.6.29	
> TDD				(no data)
Downlink information common for all radio links	OP		Downlink information common for all radio links 10.3.6.23	
Downlink information per radio link list	OP	1 to <maxRL>		Send downlink information for each radio link
>Downlink information for each radio link	MP		Downlink information for each radio link 10.3.6.26	

10.2.21 PHYSICAL CHANNEL RECONFIGURATION COMPLETE

This message is sent from the UE when a physical channel reconfiguration has been done.

RLC-SAP: AM

Logical channel: DCCH

Direction: UE → UTRAN

Information Element/Group name	Need	Multi	Type and reference	Semantics description
Message Type	MP		Message Type	
UE information elements				
<u>RRC transaction identifier</u>	<u>MP</u>		<u>RRC transaction identifier</u> 10.3.3.34a	
Integrity check info	CH		Integrity check info 10.3.3.14	
Uplink integrity protection activation info	OP		Integrity protection activation info 10.3.3.15	
CHOICE mode	MP			
>FDD				(no data)
>TDD				
>>Uplink Timing Advance	OP		Uplink Timing Advance 10.3.6.93	This information element shall be present in case of handover procedure if timing advance is enabled. Calculated timing advance value for the new cell after handover in a synchronous TDD network
RB Information elements				
Radio bearer uplink ciphering activation time info	OP		RB activation time info 10.3.4.13	
RB with PDCP information list	OP	1 to <maxRBall RABs>		This IE is needed for each RB having PDCP in the case of lossless SRNS relocation
>RB with PDCP information	MP		RB with PDCP information 10.3.4.22	

10.2.22 PHYSICAL CHANNEL RECONFIGURATION FAILURE

This message is sent by UE if the configuration given by UTRAN is unacceptable or if the UE failed to assign, replace or release a set of physical channel(s).

RLC-SAP: AM

Logical channel: DCCH

Direction: UE→UTRAN

Information Element/Group name	Need	Multi	Type and reference	Semantics description
Message type	MP		Message type	
UE information elements				
<u>RRC transaction identifier</u>	<u>OP</u>		<u>RRC transaction identifier</u> 10.3.3.34a	
Integrity check info	CH		Integrity check info 10.3.3.14	
Failure cause	MP		Failure cause and error information 10.3.3.12	

10.2.23 PHYSICAL SHARED CHANNEL ALLOCATION

NOTE: Only for TDD.

This message is used by UTRAN to assign physical resources to USCH/DSCH transport channels in TDD, for temporary usage by the UE.

RLC-SAP: UM on SHCCH, UM on DCCH

Logical channel: SHCCH or DCCH

Direction: UTRAN → UE

Information Element/Group name	Need	Multi	Type and reference	Semantics description
Message Type	MP		Message type	
C-RNTI	OP		C-RNTI 10.3.3.8	
<u>RRC transaction identifier</u>	<u>MP</u>		<u>RRC transaction identifier</u> 10.3.3.34a	
Uplink timing advance Control	MD		Uplink Timing Advance Control 10.3.6.94	Default value is the existing value for uplink timing advance
PUSCH capacity allocation info	OP		PUSCH Capacity Allocation info 10.3.6.63	
PDSCH capacity allocation info	OP		PDSCH Capacity Allocation info 10.3.6.41	
Confirm request	MD		Enumerated(No Confirm, Confirm PDSCH, Confirm PUSCH)	Default value is No Confirm
ISCP Timeslot list	OP	1 to maxTS		
>Timeslot number	MP		Timeslot number 10.3.6.81	Timeslot numbers, for which the UE shall report the timeslot ISCP in PUSCH CAPACITY REQUEST message.

10.2.24 PUSCH CAPACITY REQUEST

NOTE: Only for TDD.

This message is used by the UE for request of PUSCH resources to the UTRAN.

RLC-SAP: TM

Logical channel: SHCCH

Direction: UE → UTRAN

Information Element/Group name	Need	Multi	Type and reference	Semantics description
Message Type	MP		Message Type	
C-RNTI	OP		C-RNTI 10.3.3.8	
<u>RRC transaction identifier</u>	<u>CV-ProtErr</u>		<u>RRC transaction identifier</u> 10.3.3.34a	
Traffic Volume	OP		Traffic Volume, measured results list 10.3.7.92	
Timeslot list	OP	1 to maxTS		
>Timeslot number	MP		Timeslot number 10.3.6.81	
>Timeslot ISCP	MP			
Primary CCPCH RSCP	OP			
CHOICE Allocation confirmation	OP			
>PDSCH Confirmation	MP		Integer(1..Hi PDSCHIdentities)	
>PUSCH Confirmation	MP		Integer(1..Hi PUSCHIdentities)	
Protocol error indicator	MD		Protocol error indicator 10.3.3.27	Default value is FALSE
Protocol error information	CV-ProtErr		Protocol error information 10.3.8.10	

Condition	Explanation
ProtErr	If the IE "Protocol error indicator" has the value "TRUE"

10.2.25 RADIO BEARER RECONFIGURATION

This message is sent from UTRAN to reconfigure parameters related to a change of QoS. This procedure can also change the multiplexing of MAC, reconfigure transport channels and physical channels.

RLC-SAP: AM or UM

Logical channel: DCCH

Direction: UTRAN → UE

Information Element/Group name	Need	Multi	Type and reference	Semantics description
Message Type	MP		Message Type	
UE Information elements				
<u>RRC transaction identifier</u>	<u>MP</u>		<u>RRC transaction identifier</u> 10.3.3.34a	
Integrity check info	CH		Integrity check info 10.3.3.14	
Integrity protection mode info	OP		Integrity protection mode info 10.3.3.17	
Ciphering mode info	OP		Ciphering mode info 10.3.3.5	
Activation time	MD		Activation time 10.3.3.1	Default value is "now"
New U-RNTI	OP		U-RNTI 10.3.3.45	
New C-RNTI	OP		C-RNTI 10.3.3.8	
<u>DRX Indicator</u> <u>RRC State Indicator</u>	MP		<u>DRX Indicator</u> <u>RR C State Indicator</u> 10.3.3.10	
UTRAN DRX cycle length coefficient	MD		UTRAN DRX cycle length coefficient 10.3.3.47	Default value is the existing value of UTRAN DRX cycle length coefficient
CN information elements				
CN Information info	OP		CN Information info 10.3.1.3	
UTRAN mobility information elements				
URA identity	OP		URA identity 10.3.2.6	
RB information elements				
RAB information to reconfigure list	OP	1 to <maxRABsetup >		
>RAB information to reconfigure	MP		RAB information to reconfigure 10.3.4.11	
RB information to reconfigure list	OP	1 to <maxRB>		
>RB information to reconfigure	MP		RB information to	

Information Element/Group name	Need	Multi	Type and reference	Semantics description
			reconfigure 10.3.4.18	
RB information to be affected list	OP	1 to <maxRB>		
>RB information to be affected	MP		RB information to be affected 10.3.4.17	
TrCH Information Elements				
Uplink transport channels				
UL Transport channel information common for all transport channels	OP		UL Transport channel information common for all transport channels 10.3.5.24	
Deleted TrCH information list	OP	1 to <maxTrCH >		
> Deleted UL TrCH information	MP		Deleted UL TrCH information 10.3.5.5	
Added or Reconfigured TrCH information list	OP	1 to <maxTrCH >		
>Added or Reconfigured UL TrCH information	MP		Added or Reconfigure d UL TrCH information 10.3.5.2	
CHOICE mode	OP			
>FDD				
>>CPCH set ID	OP		CPCH set ID 10.3.5.3	
>> Added or Reconfigured TrCH information for DRAC list	OP	1 to <maxTrCH >		
>>>DRAC static information	MP		DRAC static information 10.3.5.7	
>TDD				(no data)
Downlink transport channels				
DL Transport channel information common for all transport channels	OP		DL Transport channel information common for all transport channels 10.3.5.6	
Deleted TrCH information list	OP	1 to <maxTrCH >		
>Deleted DL TrCH information	MP		Deleted DL TrCH information 10.3.5.4	
Added or Reconfigured TrCH information list	OP	1 to <maxTrCH >		
>Added or Reconfigured DL TrCH information	MP		Added or Reconfigure d DL TrCH	

Information Element/Group name	Need	Multi	Type and reference	Semantics description
			information 10.3.5.1	
PhyCH information elements				
Frequency info	MD		Frequency info 10.3.6.35	Default value is the existing value of frequency information
Uplink radio resources				
Maximum allowed UL TX power	MD		Maximum allowed UL TX power 10.3.6.38	Default value is the existing maximum UL TX power
CHOICE channel requirement	OP			At least one spare choice (criticality = reject) required
>Uplink DPCH info			Uplink DPCH info 10.3.6.86	
>PRACH Info (for RACH)			PRACH Info (for RACH) 10.3.6.51	
>CPCH SET Info			CPCH SET Info 10.3.6.12	
Downlink radio resources				
CHOICE mode	MP			
>FDD				
>>Downlink PDSCH information	OP		Downlink PDSCH information 10.3.6.29	
>TDD				(no data)
Downlink information common for all radio links	OP		Downlink information common for all radio links 10.3.6.23	
Downlink information per radio link list	OP	1 to <maxRL>		
>Downlink information for each radio link	MP		Downlink information for each radio link 10.3.6.26	

10.2.26 RADIO BEARER RECONFIGURATION COMPLETE

This message is sent from the UE when a RB and signalling link reconfiguration has been done.

RLC-SAP: AM

Logical channel: DCCH

Direction: UE → UTRAN

Information Element/Group name	Need	Multi	Type and reference	Semantics description
Message Type	MP		Message Type	
UE information elements				
<u>RRC transaction identifier</u>	<u>MP</u>		<u>RRC transaction identifier</u> 10.3.3.34a	
Integrity check info	CH		Integrity check info 10.3.3.14	
Uplink integrity protection activation info	OP		Integrity protection activation info 10.3.3.15	
CHOICE mode	MP			
>FDD				(no data)
>TDD				
>>Uplink Timing Advance	OP		Uplink Timing Advance 10.3.6.93	This information element shall be present in case of handover procedure if timing advance is enabled. Calculated timing advance value for the new cell after handover in a synchronous TDD network
RB Information elements				
Radio bearer uplink ciphering activation time info	OP		RB activation time info 10.3.4.13	
RB with PDCP information list	OP	1 to <maxRBall RABs>		This IE is needed for each RB having PDCP in the case of lossless SRNS relocation
>RB with PDCP information	MP		RB with PDCP information 10.3.4.22	

10.2.27 RADIO BEARER RECONFIGURATION FAILURE

This message is sent by UE if the configuration given by UTRAN is unacceptable or if the UE failed to establish the physical channel(s).

RLC-SAP: AM

Logical channel: DCCH

Direction: UE→UTRAN

Information Element/Group name	Need	Multi	Type and reference	Semantics description
Message Type	MP		Message Type	
UE information elements				
<u>RRC transaction identifier</u>	<u>MP</u>		<u>RRC transaction identifier</u> 10.3.3.34a	
Integrity check info	CH		Integrity check info 10.3.3.14	
Failure cause	MP		Failure cause and error information 10.3.3.12	
RB information elements				
Radio bearers for which reconfiguration would have succeeded	OP	1.to.<max RB>	RB identity, 10.3.4.16	

10.2.28 RADIO BEARER RELEASE

This message is used by UTRAN to release a radio bearer. It can also include modifications to the configurations of transport channels and/or physical channels.

RLC-SAP: AM or UM

Logical channel: DCCH

Direction: UTRAN → UE

Information Element/Group name	Need	Multi	Type and reference	Semantics description
Message Type	MP		Message Type	
UE Information Elements				
<u>RRC transaction identifier</u>	<u>MP</u>		<u>RRC transaction identifier</u> 10.3.3.34a	
Integrity check info	CH		Integrity check info 10.3.3.14	
Integrity protection mode info	OP		Integrity protection mode info 10.3.3.17	
Ciphering mode info	OP		Ciphering mode info 10.3.3.5	
Activation time	MD		Activation time 10.3.3.1	Default value is "now"
New U-RNTI	OP		U-RNTI 10.3.3.45	
New C-RNTI	OP		C-RNTI 10.3.3.8	
<u>DRX Indicator</u> <u>RRC State Indicator</u>	MP		<u>DRX Indicator</u> <u>RR C State Indicator</u> 10.3.3.10	
UTRAN DRX cycle length coefficient	MD		UTRAN DRX cycle length coefficient 10.3.3.47	Default value is the existing value of UTRAN DRX cycle length coefficient
CN Information Elements				
CN Information info	OP		CN Information info 10.3.1.3	
UTRAN mobility information elements				
URA identity	OP		URA identity 10.3.2.6	
RB Information Elements				
RAB information to reconfigure list	OP	1 to <maxRABsetup >		
>RAB information to reconfigure	MP		RAB information to reconfigure 10.3.4.11	
RB information to release list	MP	1 to <maxRB>		
>RB information to release	MP		RB information to release 10.3.4.19	
RB information to be affected list	OP	1 to <maxRB>		
>RB information to be affected	MP		RB information	

Information Element/Group name	Need	Multi	Type and reference	Semantics description
			to be affected 10.3.4.17	
TrCH Information Elements				
Uplink transport channels				
UL Transport channel information common for all transport channels	OP		UL Transport channel information common for all transport channels 10.3.5.24	
Deleted TrCH information list	OP	1 to <maxTrCH >		
>Deleted UL TrCH information	MP		Deleted UL TrCH information 10.3.5.5	
Added or Reconfigured TrCH information list	OP	1 to <maxTrCH >		
>Added or Reconfigured UL TrCH information	MP		Added or Reconfigured UL TrCH information 10.3.5.2	
CHOICE mode	OP			
>FDD				
>>CPCH set ID	OP		CPCH set ID 10.3.5.3	
>> Added or Reconfigured TrCH information for DRAC list	OP	1 to <maxTrCH >		
>>>DRAC static information	MP		DRAC static information 10.3.5.7	
>TDD				(no data)
Downlink transport channels				
DL Transport channel information common for all transport channels	OP		DL Transport channel information common for all transport channels 10.3.5.6	
Deleted TrCH information list	OP	1 to <maxTrCH >		
>Deleted DL TrCH information	MP		Deleted DL TrCH information 10.3.5.4	
Added or Reconfigured TrCH information list	OP	1 to <maxTrCH >		
>Added or Reconfigured DL TrCH information	MP		Added or Reconfigured DL TrCH information 10.3.5.1	
PhyCH information elements				
Frequency info	MD		Frequency info 10.3.6.35	Default value is the existing value of frequency information

Information Element/Group name	Need	Multi	Type and reference	Semantics description
Uplink radio resources				
Maximum allowed UL TX power	MD		Maximum allowed UL TX power 10.3.6.38	Default value is the existing maximum UL TX power
CHOICE channel requirement	OP			At least one spare choice (criticality = reject) required
>Uplink DPCH info			Uplink DPCH info 10.3.6.86	
>PRACH Info (for RACH)			PRACH Info (for RACH) 10.3.6.54	
>CPCH SET Info			CPCH SET Info 10.3.6.12	
Downlink radio resources				
CHOICE mode	MP			
>FDD				
>>Downlink PDSCH information	OP		Downlink PDSCH information 10.3.6.29	
>TDD				(no data)
Downlink information common for all radio links	OP		Downlink information common for all radio links 10.3.6.23	
Downlink information per radio link list	OP	1 to <maxRL>		Send downlink information for each radio link to be set-up
>Downlink information for each radio link	MP		Downlink information for each radio link 10.3.6.26	

10.2.29 RADIO BEARER RELEASE COMPLETE

This message is sent from the UE when radio bearer release has been completed.

RLC-SAP: AM

Logical channel: DCCH

Direction: UE → UTRAN

Information Element/Group name	Need	Multi	Type and reference	Semantics description
Message Type	MP		Message Type	
UE information elements				
<u>RRC transaction identifier</u>	<u>MP</u>		<u>RRC transaction identifier</u> 10.3.3.34a	
Integrity check info	CH		Integrity check info 10.3.3.14	Integrity check info is included if integrity protection is applied
Uplink integrity protection activation info	OP		Integrity protection activation info 10.3.3.15	
CHOICE mode	MP			
>FDD				(no data)
>TDD				
>>Uplink Timing Advance	OP		Uplink Timing Advance 10.3.6.93	This information element shall be present in case of handover procedure if timing advance is enabled. Calculated timing advance value for the new cell after handover in a synchronous TDD network
RB Information elements				
Radio bearer uplink ciphering activation time info	OP		RB activation time info 10.3.4.13	

10.2.30 RADIO BEARER RELEASE FAILURE

This message is sent by UE if the configuration given by UTRAN is unacceptable or if radio bearer can not be released.

RLC-SAP: AM

Logical channel: DCCH

Direction: UE→UTRAN

Information Element/Group name	Need	Multi	Type and reference	Semantics description
Message Type	MP		Message Type	
UE information elements				
<u>RRC transaction identifier</u>	<u>MP</u>		<u>RRC transaction identifier</u> 10.3.3.34a	
Integrity check info	CH		Integrity check info 10.3.3.14	
Failure cause	MP		Failure cause and error information 10.3.3.12	
RB information elements				
Radio bearers for which reconfiguration would have succeeded	OP	1.to.<max RB>	RB identity, 10.3.4.16	

10.2.31 RADIO BEARER SETUP

This message is sent by UTRAN to the UE to establish new radio bearer(s). It can also include modifications to the configurations of transport channels and/or physical channels.

RLC-SAP: AM or UM

Logical channel: DCCH

Direction: UTRAN → UE

Information Element/Group name	Need	Multi	Type and reference	Semantics description
Message Type	MP		Message Type	
UE Information Elements				
<u>RRC transaction identifier</u>	<u>MP</u>		<u>RRC transaction identifier</u> 10.3.3.34a	
Integrity check info	CH		Integrity check info 10.3.3.14	
Integrity protection mode info	OP		Integrity protection mode info 10.3.3.17	
Ciphering mode info	OP		Ciphering mode info 10.3.3.5	
Activation time	MD		Activation time 10.3.3.1	Default value is "now"
New U-RNTI	OP		U-RNTI 10.3.3.45	
New C-RNTI	OP		C-RNTI 10.3.3.8	
<u>DRX Indicator</u> <u>RRC State Indicator</u>	MP		<u>DRX Indicator</u> <u>RR C State Indicator</u> 10.3.3.10	
UTRAN DRX cycle length coefficient	MD		UTRAN DRX cycle length coefficient 10.3.3.47	Default value is the existing value of UTRAN DRX cycle length coefficient
CN Information Elements				
CN Information info	OP		CN Information info 10.3.1.3	
UTRAN mobility information elements				
URA identity	OP		URA identity 10.3.2.6	
RB Information Elements				
Signalling RB information to setup list	OP	1 to <maxSRBs etup>		For each signalling radio bearer established
>Signalling RB information to setup	MP		Signalling RB information to setup 10.3.4.24	
RAB information to setup list	OP	1 to <maxRABs etup>		For each RAB established
>RAB information for setup	MP		RAB information for setup 10.3.4.10	
RB information to be affected list	OP	1 to <maxRB>		
>RB information to be affected	MP		RB	

Information Element/Group name	Need	Multi	Type and reference	Semantics description
			information to be affected 10.3.4.17	
TrCH Information Elements				
Uplink transport channels				
UL Transport channel information common for all transport channels	OP		UL Transport channel information common for all transport channels 10.3.5.24	
Deleted TrCH information list	OP	1 to <maxTrCH >		
>Deleted UL TrCH information	MP		Deleted UL TrCH information 10.3.5.5	
Added or Reconfigured TrCH information list	OP	1 to <maxTrCH >		
>Added or Reconfigured UL TrCH information	MP		Added or Reconfigured UL TrCH information 10.3.5.2	
CHOICE mode	OP			
>FDD				
>>CPCH set ID	OP		CPCH set ID 10.3.5.3	
>> Added or Reconfigured TrCH information for DRAC list	OP	1 to <maxTrCH >		
>>>DRAC static information	MP		DRAC static information 10.3.5.7	
>TDD				(no data)
Downlink transport channels				
DL Transport channel information common for all transport channels	OP		DL Transport channel information common for all transport channels 10.3.5.6	
Deleted TrCH information list	OP	1 to <maxTrCH >		
>Deleted DL TrCH information	MP		Deleted DL TrCH information 10.3.5.4	
Added or Reconfigured TrCH information list	OP	1 to <maxTrCH >		
>Added or Reconfigured DL TrCH information	MP		Added or Reconfigured DL TrCH information 10.3.5.1	
PhyCH information elements				
Frequency info	MD		Frequency info	Default value is the existing value of frequency information

Information Element/Group name	Need	Multi	Type and reference	Semantics description
			10.3.6.35	
Uplink radio resources				
Maximum allowed UL TX power	MD		Maximum allowed UL TX power 10.3.6.38	Default value is the existing maximum UL TX power
CHOICE channel requirement	OP			At least one spare choice (criticality = reject) required
>Uplink DPCH info			Uplink DPCH info 10.3.6.86	
>PRACH Info (for RACH)			PRACH Info (for RACH) 10.3.6.54	
>CPCH SET Info			CPCH SET Info 10.3.6.12	
Downlink radio resources				
CHOICE mode	MP			
>FDD				
>>Downlink PDSCH information	OP		Downlink PDSCH information 10.3.6.29	
>TDD				(no data)
Downlink information common for all radio links	OP		Downlink information common for all radio links 10.3.6.23	
Downlink information per radio link list	OP	1 to <maxRL>		Send downlink information for each radio link
>Downlink information for each radio link	MP		Downlink information for each radio link 10.3.6.26	

10.2.32 RADIO BEARER SETUP COMPLETE

This message is sent by UE to confirm the establishment of the radio bearer.

RLC-SAP: AM

Logical channel: DCCH

Direction: UE → UTRAN

Information Element/Group name	Need	Multi	Type and reference	Semantics description
Message Type	MP		Message Type	
UE information elements				
<u>RRC transaction identifier</u>	<u>MP</u>		<u>RRC transaction identifier</u> 10.3.3.34a	
Integrity check info	CH		Integrity check info 10.3.3.14	
Uplink integrity protection activation info	OP		Integrity protection activation info 10.3.3.15	
CHOICE mode	OP			
>FDD				(no data)
>TDD				
>>Uplink Timing Advance	OP		Uplink Timing Advance 10.3.6.93	This information element shall be present in case of handover procedure if timing advance is enabled. Calculated timing advance value for the new cell after handover in a synchronous TDD network
START	OP		START 10.3.3.36	This information element is not needed for transparent mode RBs
RB Information elements				
Radio bearer uplink ciphering activation time info	OP		RB activation time info 10.3.4.13	

10.2.33 RADIO BEARER SETUP FAILURE

This message is sent by UE, if it does not support the configuration given by UTRAN.

RLC-SAP: AM

Logical channel: DCCH

Direction: UE→UTRAN

Information Element/Group name	Need	Multi	Type and reference	Semantics description
Message Type	MP		Message Type	
UE information elements				
<u>RRC transaction identifier</u>	<u>MP</u>		<u>RRC transaction identifier</u> 10.3.3.34a	
Integrity check info	CH		Integrity check info 10.3.3.14	
Failure cause	MP		Failure cause and error information 10.3.3.12	
RB information elements				
Radio bearers for which reconfiguration would have succeeded	OP	1.to.<max RB>	RB identity, 10.3.4.16	

10.2.34 RRC CONNECTION RE-ESTABLISHMENT

This message is sent by UTRAN in order to re-establish an RRC connection.

RLC-SAP: UM

Logical channel: CCCH, DCCH

Direction: UTRAN → UE

Information Element/Group name	Need	Multi	Type and reference	Semantics description
Message Type	MP		Message Type	
UE Information Elements				
U-RNTI	CV-CCCH		U-RNTI 10.3.3.45	
Integrity check info	CH		Integrity check info 10.3.3.14	
Integrity protection mode info	OP		Integrity protection mode info 10.3.3.17	
Ciphering mode info	OP		Ciphering mode info 10.3.3.5	
Activation time	MD		Activation time 10.3.3.1	Default value is "now"
New U-RNTI	OP		U-RNTI 10.3.3.45	
New C-RNTI	OP		C-RNTI 10.3.3.8	
DRX Indicator <u>RRC State Indicator</u>	MP		DRX Indicator <u>RR C State Indicator</u> 10.3.3.10	
UTRAN DRX cycle length coefficient	MD		UTRAN DRX cycle length coefficient 10.3.3.47	Default value is the existing value of UTRAN DRX cycle length coefficient
RLC reset indicator (for C-plane)	MP		RLC reset indicator 10.3.3.35	
RLC reset indicator (for U-plane)	MP		RLC reset indicator 10.3.3.35	
CN Information Elements				
CN Information info	OP		CN Information info 10.3.1.3	
RB Information Elements				
Signalling RB information to setup list	OP	1 to <maxSRBs etup>		For each signalling radio bearer established
>Signalling RB information to setup	MP		Signalling RB information to setup 10.3.4.24	
RAB information for setup list	OP	1 to <maxRABs etup>		For each RAB established
>RAB information for setup	MP		RAB information for setup 10.3.4.10	
RB information to release list	OP	1 to <maxRB>		
>RB information to release	MP		RB	

Information Element/Group name	Need	Multi	Type and reference	Semantics description
			information to release 10.3.4.19	
RB information to reconfigure list	OP	1 to <maxRB>		
>RB information to reconfigure	MP		RB information to reconfigure 10.3.4.18	
RB information to be affected list	OP	1 to <maxRB>		
>RB information to be affected	MP		RB information to be affected 10.3.4.17	
TrCH Information Elements				
Uplink transport channels				
UL Transport channel information common for all transport channels	OP		UL Transport channel information common for all transport channels 10.3.5.24	
Deleted TrCH information list	OP	1 to <maxTrCH >		
>Deleted UL TrCH information	MP		Deleted UL TrCH information 10.3.5.5	
Added or Reconfigured TrCH information list	OP	1 to <maxTrCH >		
>Added or Reconfigured UL TrCH information	MP		Added or Reconfigured UL TrCH information 10.3.5.2	
CHOICE mode	OP			
>FDD				
>>CPCH set ID	OP		CPCH set ID 10.3.5.3	
>> Added or Reconfigured TrCH information for DRAC list	OP	1 to <maxTrCH >		
>>>DRAC static information	MP		DRAC static information 10.3.5.7	
>TDD				(no data)
Downlink transport channels				
DL Transport channel information common for all transport channels	OP		DL Transport channel information common for all transport channels 10.3.5.6	
Deleted TrCH information list	OP	1 to <maxTrCH >		
>Deleted DL TrCH information	MP		Deleted DL TrCH	

Information Element/Group name	Need	Multi	Type and reference	Semantics description
			information 10.3.5.4	
Added or Reconfigured TrCH information list	OP	1 to <maxTrCH >		
>Added or Reconfigured DL TrCH information	MP		Added or Reconfigured DL TrCH information 10.3.5.1	
PhyCH information elements				
Frequency info	MD		Frequency info 10.3.6.35	Default value is the existing value of frequency information
Uplink radio resources				
Maximum allowed UL TX power	MD		Maximum allowed UL TX power 10.3.6.38	Default value is the existing maximum UL TX power
CHOICE channel requirement	OP			At least one spare choice (criticality = reject) required
>Uplink DPCH info			Uplink DPCH info 10.3.6.86.	
>PRACH Info (for RACH)			PRACH Info (for RACH) 10.3.6.51	
>CPCH SET Info			CPCH SET Info 10.3.6.12	
Downlink radio resources				
CHOICE mode				
>FDD				
>>Downlink PDSCH information	OP		Downlink PDSCH information 10.3.6.29	
>TDD				(no data)
Downlink information common for all radio links	OP		Downlink information common for all radio links 10.3.6.23	
Downlink information per radio link list	OP	1 to <maxRL>		Send downlink information for each radio link to be set-up
>Downlink information for each radio link	MP		Downlink information for each radio link 10.3.6.26	

Condition	Explanation
CCCH	This IE is only sent when CCCH is used

10.2.35 RRC CONNECTION RE-ESTABLISHMENT COMPLETE

This message is used by UE to confirm the re-establishment of an RRC connection.

RLC-SAP: AM

Logical channel: DCCH

Direction: UE → UTRAN

Information Element/Group name	Need	Multi	Type and reference	Semantics description
Message Type	MP		Message Type	
UE information elements				
Integrity check info	CH		Integrity check info 10.3.3.14	
Uplink integrity protection activation info	OP		Integrity protection activation info 10.3.3.15	
CHOICE mode	OP			
>FDD				(no data)
>TDD				
>>Uplink Timing Advance	OP		Uplink Timing Advance 10.3.6.93	This information element shall be present in case of handover procedure if timing advance is enabled. Calculated timing advance value for the new cell after handover in a synchronous TDD network
START	OP		START 10.3.3.36	
RB Information elements				
Radio bearer uplink ciphering activation time info	OP		RB activation time info 10.3.4.13	
RB with PDCP information list	OP	1 to <maxRBall RABs>		This IE is needed for each RB having PDCP in the case of lossless SRNS relocation
>RB with PDCP information	MP		RB with PDCP information 10.3.4.22	

10.2.36 RRC CONNECTION RE-ESTABLISHMENT REQUEST

This message is used by UE to request for the re-establishment of an RRC connection.

RLC-SAP: TM

Logical channel: CCCH

Direction: UE → UTRAN

Information Element/Group name	Need	Multi	Type and reference	Semantics description
Message Type	MP		Message Type	
UE information elements				
U-RNTI	MP		U-RNTI 10.3.3.45	
Integrity check info	CH		Integrity check info 10.3.3.14	
START list	MP	1 to <maxCNdomains>		START [TS 33.102] values for all CN domains.
>CN domain identity	MP		CN domain identity 10.3.1.1	
>START	MP		START 10.3.3.36	START value to be used in this CN domain.
AM_RLC error indication(for C-plane)	MP		Boolean	TRUE indicates AM_RLC unrecoverable error occurred on c-plane in the UE
AM_RLC error indication(for U-plane)	MP		Boolean	TRUE indicates AM_RLC unrecoverable error occurred on u-plane in the UE
Protocol error indicator	MD		Protocol error indicator 10.3.3.27	Default value is FALSE
Measurement information elements				
Measured results on RACH	OP		Measured results on RACH 10.3.7.70	
Other information elements				
Protocol error information	CV-ProtErr		Protocol error information 10.3.8.10	

Condition	Explanation
ProtErr	If the IE "Protocol error indicator" has the value "TRUE"

10.2.37 RRC CONNECTION REJECT

The network transmits this message when the requested RRC connection cannot be accepted.

RLC-SAP: UM

Logical channel: CCCH

Direction: UTRAN → UE

Information Element/Group name	Need	Multi	Type and reference	Semantics description
Message Type	MP		Message Type	
UE information elements				
Initial UE identity	MP		Initial UE identity 10.3.3.13	
<u>RRC transaction identifier</u>	<u>MP</u>		<u>RRC transaction identifier</u> 10.3.3.34a	
Rejection cause	MP		Rejection cause 10.3.3.30	
Wait time	MP		Wait time 10.3.3.48	
Redirection info	OP		Redirection info 10.3.3.28	

10.2.38 RRC CONNECTION RELEASE

This message is sent by UTRAN to release the RRC connection. The message also releases the signalling connection and all radio bearers between the UE and UTRAN.

RLC-SAP: UM ~~or TM~~

Logical channel: CCCH or DCCH

Direction: UTRAN→UE

Information Element/Group name	Need	Multi	Type and reference	Semantics description
Message Type	MP		Message Type	
UE information elements				
U-RNTI	CV-CCCH		U-RNTI 10.3.3.45	
<u>RRC transaction identifier</u>	<u>MP</u>		<u>RRC transaction identifier</u> 10.3.3.34a	
Integrity check info	CH		Integrity check info 10.3.3.14	Integrity check info is included if integrity protection is applied
Number of RRC Message Transmissions	CH Cell_DCH		Number of RRC Message Transmissions 10.3.3.21	
Release cause	MP		Release cause 10.3.3.31	

Condition	Explanation
CCCH	This IE is only sent when CCCH is used.
Cell_DCH	This IE is present when UE is in CELL_DCH state.

10.2.39 RRC CONNECTION RELEASE COMPLETE

This message is sent by UE to confirm that the RRC connection has been released.

RLC-SAP: AM or UM ~~or TM~~

Logical channel: ~~CCCH~~ or DCCH

Direction: UE → UTRAN

Information Element/Group name	Need	Multi	Type and reference	Semantics description
Message Type	MP		Message Type	
UE information elements				
U-RNTI	CV-CCCH		U-RNTI 10.3.3.45	
RRC transaction identifier	MP		RRC transaction identifier 10.3.3.34a	
Integrity check info	CH		Integrity check info 10.3.3.14	
Error indication	OP		Failure cause and error information 10.3.3.12	

Condition	Explanation
CCCH	This IE is only sent when CCCH is used.

10.2.40 RRC CONNECTION REQUEST

RRC Connection Request is the first message transmitted by the UE when setting up an RRC Connection to the network.

RLC-SAP: TM

Logical channel: CCCH

Direction: UE → UTRAN

Information Element/Group name	Need	Multi	Type and reference	Semantics description
Message Type	MP		Message Type	
UE information elements				
Initial UE identity	MP		Initial UE identity 10.3.3.13	
Establishment cause	MP		Establishme nt cause 10.3.3.11	
Protocol error indicator	MD		Protocol error indicator 10.3.3.27	Default value is FALSE
Measurement information elements				
Measured results on RACH	OP		Measured results on RACH 10.3.7.70	

If the encoded message does not fill a transport block, the RRC layer shall insert padding according to subclause 12.1.

10.2.41 RRC CONNECTION SETUP

This message is used by the network to accept the establishment of an RRC connection for an UE, including assignment of signalling link information, transport channel information and optionally physical channel information.

RLC-SAP: UM

Logical channel: CCCH

Direction: UTRAN → UE

Information Element/Group name	Need	Multi	Type and reference	Semantics description
Message Type	MP		Message Type	
UE Information Elements				
Initial UE identity	MP		Initial UE identity 10.3.3.13	
<u>RRC transaction identifier</u>	<u>MP</u>		<u>RRC transaction identifier</u> 10.3.3.34a	
Activation time	MD		Activation time 10.3.3.1	Default value is "now"
New U-RNTI	MP		U-RNTI 10.3.3.45	
New C-RNTI	OP		C-RNTI 10.3.3.8	
UTRAN DRX cycle length coefficient	MP		UTRAN DRX cycle length coefficient 10.3.3.47	
Capability update requirement	MD		Capability update requirement 10.3.3.2	Default value is defined in subclause 10.3.3.3
<u>RRC State Indicator</u>			<u>RRC State Indicator</u> 10.3.3.10	<u>Only values CELL_DCH or CELL_FACH can be allocated by UTRAN in this message.</u>
RB Information Elements				
Signalling RB information to setup list	MP	3 to 4		Information for signalling radio bearers, in the order RB 1 up to 4.
>Signalling RB information to setup	MP		Signalling RB information to setup 10.3.4.24	
TrCH Information Elements				
Uplink transport channels				
UL Transport channel information common for all transport channels	OP		UL Transport channel information common for all transport channels 10.3.5.24	
Added or Reconfigured TrCH information list	MP	1 to <maxTrCH >		
>Added or Reconfigured UL TrCH information	MP		Added or Reconfigured UL TrCH information 10.3.5.2	
Downlink transport channels				

Information Element/Group name	Need	Multi	Type and reference	Semantics description
DL Transport channel information common for all transport channels	OP		DL Transport channel information common for all transport channels 10.3.5.6	
Added or Reconfigured TrCH information list	MP	1 to <maxTrCH>		
>Added or Reconfigured DL TrCH information	MP		Added or Reconfigured DL TrCH information 10.3.5.1	
PhyCH information elements				
Frequency info	MD		Frequency info 10.3.6.35	Default value is the existing value of frequency information
Uplink radio resources				
Maximum allowed UL TX power	MD		Maximum allowed UL TX power 10.3.6.38	Default value is the existing maximum UL TX power
CHOICE channel requirement	OP			At least one spare choice (criticality = reject) required
>Uplink DPCH info			Uplink DPCH info 10.3.6.86	
>PRACH Info (for RACH)			PRACH Info (for RACH) 10.3.6.51	
>CPCH SET Info			CPCH SET Info 10.3.6.12	
Downlink radio resources				
Downlink information common for all radio links	OP		Downlink information common for all radio links 10.3.6.23	
Downlink information per radio link list	OP	1 to <MaxRL>		Send downlink information for each radio link to be set-up
>Downlink information for each radio link	MP		Downlink information for each radio link 10.3.6.26	

10.2.42 RRC CONNECTION SETUP COMPLETE

This message confirms the establishment of the RRC Connection by the UE.

RLC-SAP: AM

Logical channel: DCCH

Direction: UE → UTRAN

Information Element/Group name	Need	Multi	Type and reference	Semantics description
Message Type	MP		Message Type	
<u>UE Information Elements</u>				
<u>RRC transaction identifier</u>	<u>MP</u>		<u>RRC transaction identifier</u> 10.3.3.34a	
START list	MP	1 to <maxCNdomains>		START [TS 33.102] values for all CN domains.
>CN domain identity	MP		CN domain identity 10.3.1.1	
>START	MP		START 10.3.3.36	START value to be used in this CN domain.
<u>UE information elements</u>				
UE radio access capability	OP		UE radio access capability 10.3.3.40	
UE system specific capability	OP		Inter-system message 10.3.8.6	

10.2.43 RRC STATUS

This message is sent to indicate a protocol error.

RLC-SAP: AM

Logical channel: DCCH

Direction: UE→UTRAN

Information Element/Group name	Need	Multi	Type and reference	Semantics description
Message Type	MP		Message Type	
<u>UE information elements</u>				
Integrity check info	CH		Integrity check info 10.3.3.14	Integrity check info is included if integrity protection is applied
<u>Identification of received message</u>	<u>CV-Message identified</u>			
> <u>Received message type</u>	<u>MP</u>		<u>Message Type</u>	
> <u>RRC transaction identifier</u>	<u>MP</u>		<u>RRC transaction identifier</u> 10.3.3.34a	
<u>Other information elements</u>				
Protocol error information	MP		Protocol error information 10.3.8.10	

Condition	Explanation
<u>Message identified</u>	If the IE "Protocol error cause" in the IE "Protocol error information" has any other value than "ASN.1 violation or encoding error" or "Message type non-existent or not implemented"

10.2.44 SECURITY MODE COMMAND

This message is sent by UTRAN to start or reconfigure ciphering and/or integrity protection parameters.

RLC-SAP: AM

Logical channel: DCCH

Direction: UTRAN to UE

Information Element/Group name	Need	Multi	Type and reference	Semantics description
Message Type	MP		Message Type	
UE information elements				
<u>RRC transaction identifier</u>	<u>MP</u>		<u>RRC transaction identifier</u> 10.3.3.34a	
Integrity check info	MP		Integrity check info 10.3.3.14	
Security capability	MP		Security capability 10.3.3.36	
Ciphering mode info	OP		Ciphering mode info 10.3.3.5	Only present if ciphering shall be controlled
Integrity protection mode info	OP		Integrity protection mode info 10.3.3.1718	Only present if integrity protection shall be controlled
CN Information elements				
CN domain identity	MP		CN domain identity 10.3.1.1	Indicates which cipher and integrity protection keys are applicable

10.2.45 SECURITY MODE COMPLETE

This message is sent by UE to confirm the reconfiguration of ciphering and/or integrity protection.

RLC-SAP: AM

Logical channel: DCCH

Direction: UE to UTRAN

Information Element/Group name	Need	Multi	Type and reference	Semantics description
Message Type	MP		Message Type	
UE information elements				
<u>RRC transaction identifier</u>	<u>MP</u>		<u>RRC transaction identifier</u> 10.3.3.34a	
Integrity check info	MP		Integrity check info 10.3.3.14	
Uplink integrity protection activation info	OP		Integrity protection activation info 10.3.3.15	
RB Information elements				
Radio bearer uplink ciphering activation time info	OP		RB activation time info 10.3.4.13	

10.2.46 SECURITY MODE FAILURE

This message is sent to indicate a failure to act on a received SECURITY MODE CONTROL message.

RLC-SAP: AM

Logical channel: DCCH

Direction: UE→UTRAN

Information Element/Group name	Need	Multi	Type and reference	Semantics description
Message Type	MP		Message Type	
UE information elements				
<u>RRC transaction identifier</u>	<u>MP</u>		<u>RRC transaction identifier</u> 10.3.3.34a	
Integrity check info	CH		Integrity check info 10.3.3.14	
Failure cause	MP		Failure cause and error information 10.3.3.12	

10.2.47 SIGNALLING CONNECTION RELEASE

This message is used to notify the UE that one of its ongoing signalling connections to a CN domain has been released.

RLC-SAP: AM

Logical channel: DCCH

Direction: UTRAN→UE

Information Element/Group name	Need	Multi	Type and reference	Semantics description
Message Type	MP		Message Type	
UE information elements				
Integrity check info	CH		Integrity check info 10.3.3.14	Integrity check info is included if integrity protection is applied
CN information elements				
Signalling Flow related information list	MP	1 to <maxSignallingFlow>		Flow identifier to be provided for each signalling flow to be released.
>Flow Identifier	MP		Flow Identifier 10.3.1.4	

10.2.48 SIGNALLING CONNECTION RELEASE REQUEST

This message is used by the UE to request for the release of a signalling flow.

RLC-SAP: AM

Logical channel: DCCH

Direction: UE→UTRAN

Information Element/Group name	Need	Multi	IE type and reference	Semantics description
Message Type	MP		Message type	
CN information elements				
Flow Identifier	MP		Flow Identifier 10.3.1.4	Flow identifier of signalling flow to be released by UTRAN.

10.2.49 SYSTEM INFORMATION

Information Element/Group name	Need	Multi	Type and reference	Semantics description
Message type	OP		Message type	The message type is mandatory on the FACH, and absent on the BCH
SFNprime	CV channel		Integer(0..4094 by step of 2)	SFN=SFNprime (for first 10ms frame of 20ms TTI), SFN=SFNprime+1 (for last 10ms frame of 20ms TTI)
CHOICE Segment combination	MP			
>Combination 1				(no data)
>Combination 2				
>>First Segment	MP		First Segment, 10.2.49.1	
>Combination 3				
>>Subsequent Segment	MP		Subsequent Segment, 10.2.49.3	
>Combination 4				
>>Last segment	MP		Last segment (short), 10.2.49.5	
>Combination 5				
>>Last segment	MP		Last Segment (short) 10.2.49.5	
>>First Segment	MP		First Segment (short), 10.2.49.2	
>Combination 6				
>>Last Segment	MP		Last Segment (short), 10.2.49.5	
>>Complete list		1 to maxSIBper Msg		Note 1
>>>Complete			Complete SIB (short), 10.2.49.7	
>Combination 7				
>>Last Segment	MP		Last Segment (short), 10.2.49.5	
>>Complete list	MP	1..16		Note 1
>>>Complete	MP		Complete SIB (short), 10.2.49.7	
>>First Segment	MP		First Segment (short), 10.2.49.2	
>Combination 8				
>>Complete list	MP	1 to maxSIBper Msg		Note 1
>>>Complete	MP		Complete SIB (short), 10.2.49.7	
>Combination 9				

>>Complete list	MP	1..MaxSIB perMsg		Note 1
>>>Complete	MP		Complete SIB (short), 10.2.49.7	
>>First Segment	MP		First Segment (short), 10.2.49.2	
>Combination 10				
>>> Complete SIB of size 215 to 222	MP		Complete SIB, 10.2.49.6	
>Combination 11				
>>Last segment of size 215 to 222	MP		Last segment, 10.2.49.4	

If the encoded message does not fill a transport block, the RRC layer shall insert padding according to subclause 12.1. Padding is needed e.g. if the remaining space is insufficient to start a new First Segment (which requires several bits for SIB type, SEG_COUNT and SIB data).

NOTE 1: If Combination 6 - 9 contains a Master information block Master information shall be located as the first IE in the list.

10.2.49.1 First Segment

This segment type is used to transfer the first segment of a segmented system information block. The IE is used when the first segment fills the entire transport block (Combination 1).

Information Element/Group name	Need	Multi	Type and reference	Semantics description
Other information elements				
SIB type	MP		SIB Type, 10.3.8.17	
SEG_COUNT	MP		SEG COUNT, 10.3.8.13	
SIB data fixed	MP		SIB data fixed, 10.3.8.15	

10.2.49.2 First Segment (short)

This segment type is used to transfer the first segment of a segmented system information block. The IE is used when the first segment is concatenated after other segments in a transport block (Combination 5, 7 and 9).

Information Element/Group name	Need	Multi	Type and reference	Semantics description
Other information elements				
SIB type	MP		SIB Type, 10.3.8.17	
SEG_COUNT	MP		SEG COUNT, 10.3.8.13	
SIB data variable	MP		SIB data variable, 10.3.8.16	

10.2.49.3 Subsequent Segment

This segment type is used to transfer a subsequent segment of a segmented system information block.

Information Element/Group name	Need	Multi	Type and reference	Semantics description
Other information elements				
SIB type	MP		SIB Type, 10.3.8.17	
Segment index	MP		Segment Index, 10.3.8.14	
SIB data fixed	MP		SIB data fixed, 10.3.8.15	

10.2.49.4 Last Segment

This segment type is used to transfer the last segment of a segmented system information block. The IE is used when the last segment has a length, excluding length denominator, from 215 through 222 (Combination 11).

Information Element/Group name	Need	Multi	Type and reference	Semantics description
Other information elements				
SIB type	MP		SIB Type, 10.3.8.17	
Segment index	MP		Segment Index, 10.3.8.14	
SIB data fixed	MP		SIB data fixed, 10.3.8.15	In case the SIB data is less than 222 bits, padding shall be used. The same padding bits shall be used as defined in clause 12.1

10.2.49.5 Last Segment (short)

This segment type is used to transfer the last segment of a segmented system information block. The IE is used when the last segment has a length, excluding length denominator, of upto 214 bits (Combination 4, 5, 6 and 7).

Information Element/Group name	Need	Multi	Type and reference	Semantics description
Other information elements				
SIB type	MP		SIB Type, 10.3.8.17	
Segment index	MP		Segment Index, 10.3.8.14	
SIB data variable	MP		SIB data variable, 10.3.8.15	

10.2.49.6 Complete SIB

This segment type is used to transfer a non-segmented system information block. The IE is used when the complete SIB has a length, excluding length denominator, from 215 through 222 (Combination 10).

Information Element/Group name	Need	Multi	Type and reference	Semantics description
Other information elements				
SIB type	MP		SIB Type, 10.3.8.17	
SIB data fixed	MP		SIB data fixed, 10.3.8.15	In case the SIB data is less than 222 bits, padding shall be used. The same padding bits shall be used as defined in clause 12.1

10.2.49.7 Complete SIB (short)

This segment type is used to transfer a non-segmented system information block. The IE is used when the complete SIB has a length, excluding length denominator, of upto 214 bits (Combination 6, 7, 8, 9 and 10).

Information Element/Group name	Need	Multi	Type and reference	Semantics description
Other information elements				
SIB type	MP		SIB Type, 10.3.8.17	
SIB data variable	MP		10.2.49.6 SIB data variable, 10.3.8.16	

10.2.49.8 System Information Blocks

The IE "SIB data" within the IEs, "First Segment", "Subsequent or last Segment" and "Complete SIB" contains either complete system information block or a segment of a system information block. The actual system information blocks are defined in the following clauses.

10.2.49.8.1 Master Information Block

Information Element/Group name	Need	Multi	Type and reference	Semantics description
Other information elements				
MIB Value tag	MP		MIB Value tag 10.3.8.7	
CN information elements				
Supported PLMN types	MP		PLMN Type 10.3.1.12	
PLMN Identity	CV GSM		PLMN Identity 10.3.1.11	
ANSI-41 information elements				
ANSI-41 Core Network Information	CV ANSI-41		ANSI-41 Core Network Information 10.3.9.1	
References to other system information blocks	MP		References to other system information blocks 10.3.8.11	

Condition	Explanation
GSM	The IE is mandatory if the IE "Supported PLMN Types" is set to 'GSM-MAP' or 'GSM-MAP AND ANSI-41', and not needed otherwise
ANSI-41	The IE is mandatory if the IE "Supported PLMN Types" is set to 'ANSI-41' or 'GSM-MAP AND ANSI-41', and not needed otherwise

10.2.49.8.2 System Information Block type 1

The system information block type 1 contains NAS system information as well as UE timers and counters to be used in idle mode and in CELL_DCH.

Information Element/Group name	Need	Multi	Type and reference	Semantics description
References to other system information blocks	OP		References to other system information blocks 10.3.8.11	Only system information blocks with area scope "PLMN" and update mechanism "value tag" may be referenced.
CN information elements				
CN common GSM-MAP NAS system information	MP		NAS system information (GSM-MAP) 10.3.1.9	
CN domain system information list	MP	1 to <maxCNdomains>		Send CN information for each CN domain.
>CN domain system information	MP		CN domain system information 10.3.1.2	
UE information				
UE Timers and constants in CELL_DCH	MD		UE Timers and constants in CELL_DCH 10.3.3.41	Default value means that for all timers and constants - For parameters with need MD, the defaults specified in 10.3.3.41 apply and - For parameters with need OP, the parameters are absent
UE Timers and constants in idle mode	MD		UE Timers and constants in idle mode 10.3.3.43	Default value means that for all timers and constants - For parameters with need MD, the defaults specified in 10.3.3.43 apply and - For parameters with need OP, the parameters are absent

10.2.49.8.3 System Information Block type 2

The system information block type 2 contains the URA identity and information for periodic cell and URA update. It also includes the UE timers and counters to be used in connected mode.

Information Element/Group name	Need	Multi	Type and reference	Semantics description
References to other system information blocks	OP		References to other system information blocks 10.3.8.11	Only system information blocks with area scope "PLMN" and update mechanism "value tag" may be referenced.
UTRAN mobility information elements				
URA identity list	MP	1 ..<maxURA>		
>URA identity	MP		URA identity 10.3.2.6	
UE information elements				
UE Timers and constants in connected mode	MP		UE Timers and constants in connected mode 10.3.3.42	Default value means that for all timers and constants - For parameters with need MD, the defaults specified in 10.3.3.42 apply and - For parameters with need OP, the parameters are absent

10.2.49.8.4 System Information Block type 3

The system information block type 3 contains parameters for cell selection and re-selection. The block may also contain scheduling information for other system information blocks.

Information Element/Group name	Need	Multi	Type and reference	Semantics description
References to other system information blocks	OP		References to other system information blocks 10.3.8.11	Only system information blocks with area scope "Cell" and update mechanism "value tag" may be referenced.
UTRAN mobility information elements				
Cell identity	MP		Cell identity 10.3.2.2	
Cell selection and re-selection info	MP		Cell selection and re-selection info for SIB3/4 10.3.2.3	
Cell Access Restriction	MP		Cell Access Restriction 10.3.2.1	

10.2.49.8.5 System Information Block type 4

The system information block type 4 contains parameters for cell selection and re-selection to be used in connected mode. The block may also contain scheduling information for other system information blocks.

Information Element/Group name	Need	Multi	Type and reference	Semantics description
References to other system information blocks	OP		References to other system information blocks 10.3.8.11	Only system information blocks with area scope "Cell" and update mechanism "value tag" may be referenced.
UTRAN mobility information elements				
Cell identity	MP		Cell identity 10.3.2.2	
Cell selection and re-selection info	MP		Cell selection and re-selection info for SIB3/4 10.3.2.3	
Cell Access Restriction	MP		Cell Access Restriction 10.3.2.1	

10.2.49.8.6 System Information Block type 5

The system information block type 5 contains parameters for the configuration of the common physical channels in the cell. The block may also contain scheduling information for other system information blocks.

Information Element/Group name	Need	Multi	Type and reference	Semantics description
References to other system information blocks	OP		References to other system information blocks 10.3.8.11	Only system information blocks with area scope "Cell" and update mechanism "value tag" may be referenced.
PhyCH information elements				
CHOICE mode	MP			
>FDD				
>>PICH Power offset	MP		PICH Power offset 10.3.6.49	
>>AICH Power offset	MP		AICH Power offset 10.3.6.3	
>TDD				
>>PUSCH system information	OP		PUSCH system information 10.3.6.65	
>>PDSCH system information	OP		PDSCH system information 10.3.6.45	
>>Midamble configuration	MD		Midamble configuration 10.3.6.39	Default value is defined in 10.3.6.39

>>Primary CCPCH Tx Power	OP		Primary CCPCH Tx Power 10.3.6.58	For path loss calculation
>>PRACH Constant Value	OP		Constant Value 10.3.6.10	Operator controlled PRACH Margin
>>DPCH Constant Value	OP		Constant Value 10.3.6.10	Operator controlled UL DPCH Margin
>>PUSCH Constant Value	OP		Constant Value 10.3.6.10	Operator controlled PUSCH Margin
Primary CCPCH info	OP		Primary CCPCH info 10.3.6.56	Note 1
PRACH system information list	MP		PRACH system information list 10.3.6.54	
Secondary CCPCH system information	MP		Secondary CCPCH system information 10.3.6.71	
CBS DRX Level 1 information	CV CTCH		CBS DRX Level 1 information 10.3.8.3	

NOTE 1: DL scrambling code of the Primary CCPCH is the same as the one for Primary CPICH (FDD only).

Condition	Explanation
CTCH	The IE is mandatory if the IE "CTCH indicator" is equal to TRUE for at least one FACH, otherwise the IE is not needed in the message

10.2.49.8.7 System Information Block type 6

The system information block type 6 contains parameters for the configuration of the common and shared physical channels to be used in connected mode. The block may also contain scheduling information for other system information blocks.

Information Element/Group name	Need	Multi	Type and reference	Semantics description
References to other system information blocks	OP		References to other system information blocks 10.3.8.11	Only system information blocks with area scope "Cell" and update mechanism "value tag" may be referenced.
PhyCH information elements				
CHOICE mode	MP			
>FDD				
>>PICH Power offset	MP		PICH Power offset 10.3.6.49	
>>AICH Power offset	MP		AICH Power offset 10.3.6.3	
>>CSICH Power offset	OP		CSICH Power offset 10.3.6.14	
>TDD				
>>PUSCH system information	OP		PUSCH system information 10.3.6.65	
>>PDSCH system information	OP		PDSCH system information 10.3.6.45	
>>Midamble configuration	MD		Midamble configuration 10.3.6.39	Default value is defined in 10.3.6.39

>>Primary CCPCH Tx Power	OP		Primary CCPCH Tx Power 10.3.6.58	For path loss calculation
>>PRACH Constant Value	OP		Constant Value 10.3.6.10	Operator controlled PRACH Margin for SF 16 case. In the SF 8 case 3dB is added.
>>DPCH Constant Value	OP		Constant Value 10.3.6.10	Operator controlled UL DPCH Margin
>>PUSCH Constant Value	OP		Constant Value 10.3.6.10	Operator controlled PUSCH Margin
Primary CCPCH info	OP		Primary CCPCH info 10.3.6.56	Note 1
PRACH system information list	MP		PRACH system information list 10.3.6.54	
Secondary CCPCH system information	MP		Secondary CCPCH system information 10.3.6.71	
CBS DRX Level 1 information	CV CTCH		CBS DRX Level 1 information 10.3.8.3	

NOTE 1: DL scrambling code of the Primary CCPCH is the same as the one for Primary CPICH (FDD only).

Condition	Explanation
CTCH	The IE is mandatory if the IE "CTCH indicator" is equal to TRUE for at least one FACH, otherwise the IE is not needed

10.2.49.8.8 System Information Block type 7

The system information block type 7 contains the fast changing parameters UL interference and Dynamic persistence level

Information Element/Group name	Need	Multi	Type and reference	Semantics description
References to other system information blocks	OP		References to other system information blocks 10.3.8.11	Only system information blocks with area scope "Cell" and update mechanism "expiration timer" may be referenced.
CHOICE mode	MP			
>FDD				
>>UL interference	MP		UL interference 10.3.6.85	
>TDD				(no data)
PhyCH information elements				
PRACHs listed in system information block type 5	MP	1 to <maxPRACH>		The order of the PRACHs is the same as in system information block type 5.
>Dynamic persistence level	MP		Dynamic persistence level 10.3.6.34	
PRACHs listed in system information block type 6	OP	1 to <maxPRA CH>		The order of the PRACHs is the same as in system information block type 6.
>Dynamic persistence level	MP		Dynamic persistence level 10.3.6.34	

10.2.49.8.9 System Information Block type 8

NOTE: Only for FDD.

The system information block type 8 contains static CPCH information to be used in the cell.

Information Element/Group name	Need	Multi	Type and reference	Semantics description
References to other system information blocks	OP		References to other system information blocks 10.3.8.11	Only system information blocks with area scope "Cell" and update mechanism "value tag" may be referenced.
UE information				
CPCH parameters	MP		CPCH parameters 10.3.3.7	
PhyCH information elements				
CPCH set info list	MP	1 to <maxCPC Hsets>		
>CPCH set info	MP		CPCH set info 10.3.6.12	

10.2.49.8.10 System Information Block type 9

NOTE: Only for FDD.

The system information block type 9 contains CPCH information to be used in the cell.

Information Element/Group name	Need	Multi	Type and reference	Semantics description
References to other system information blocks	OP		References to other system information blocks 10.3.8.11	Only system information blocks with area scope "Cell" and update mechanism "expiration timer" may be referenced.
PhyCH information elements				
CPCH set persistence levels list	MP	..1 to <maxCPC Hsets>		
>CPCH set persistence levels	MP		CPCH persistence levels 10.3.6.11	

10.2.49.8.11 System Information Block type 10

NOTE: Only for FDD.

The system information block type 10 contains information to be used by UEs having their DCH controlled by a DRAC procedure.

Information Element/Group name	Need	Multi	Type and reference	Semantics description
References to other system information blocks	OP		References to other system information blocks 10.3.8.11	Only system information blocks with area scope "Cell" and update mechanism "expiration timer" may be referenced.
UE information				
DRAC system information	MP		DRAC system information 10.3.3.9	DRAC information is sent for each class of terminal

10.2.49.8.12 System Information Block type 11

The system information block type 11 contains measurement control information to be used in the cell. The block may also contain scheduling information for other system information blocks.

Information Element/Group name	Need	Multi	Type and reference	Semantics description
References to other system information blocks	OP		References to other system information blocks 10.3.8.11	Only system information blocks with area scope "Cell" and update mechanism "value tag" may be referenced.
Measurement information elements				
FACH measurement occasion info	OP		FACH measurement occasion info 10.3.7.8	
Measurement control system information	MP		Measurement control system information 10.3.7.72	

10.2.49.8.13 System Information Block type 12

The system information block type 12 contains measurement control information to be used in connected mode.

Information Element/Group name	Need	Multi	Type and reference	Semantics description
References to other system information blocks	OP		References to other system information blocks 10.3.8.11	Only system information blocks with area scope "Cell" and update mechanism "value tag" may be referenced.
Measurement information elements				
FACH measurement occasion info	OP		FACH measurement occasion info 10.3.7.8	
Measurement control system information	MP		Measurement control system information 10.3.7.72	

10.2.49.8.14 System Information Block type 13

The system information block type 13 contains ANSI-41 system information.

Information Element/Group name	Need	Multi	Type and reference	Semantics description
Other information elements				
References to other system information blocks	OP		References to other system information blocks 10.3.8.11	Only system information blocks with area scope "Cell" and update mechanism "value tag" may be referenced.
CN Information Elements				
CN Domain system information list		1 to <maxCNdomains>		Send CN information for each CN domain.
>CN Domain system information			CN Domain system information 10.3.1.2	
UE Information				
UE timers and constants in idle mode	OP		UE timers and constants in idle mode 10.3.3.43	
Capability update requirement	OP		Capability update requirement 10.3.3.2	

10.2.49.8.14.1 System Information Block type 13.1

The system information block type 13.1 contains the ANSI-41 RAND information.

Information Element/Group name	Need	Multi	Type and reference	Semantics description
ANSI-41 information elements				
ANSI-41 RAND information	MP		ANSI-41 RAND information 10.3.9.6	

10.2.49.8.14.2 System Information Block type 13.2

The system information block type 13.2 contains the ANSI-41 User Zone Identification information.

Information Element/Group name	Need	Multi	Type and reference	Semantics description
ANSI-41 information elements				
ANSI-41 User Zone Identification information	MP		ANSI-41 User Zone Identification information 10.3.9.7	

10.2.49.8.14.3 System Information Block type 13.3

The system information block type 13.3 contains the ANSI-41 Private Neighbor/Neighbour List information.

Information Element/Group name	Need	Multi	Type and reference	Semantics description
ANSI-41 information elements				
ANSI-41 Private Neighbor/Neighbour List information	MP		ANSI-41 Private Neighbor/Neighbour List information 10.3.9.5	

10.2.49.8.14.4 System Information Block type 13.4

The system information block type 13.4 contains the ANSI-41 Global Service Redirection information.

Information Element/Group name	Need	Multi	Type and reference	Semantics description
ANSI-41 information elements				
ANSI-41 Global Service Redirection information	MP		ANSI-41 Global Service Redirection information 10.3.9.2	

10.2.49.8.15 System Information Block type 14

NOTE: Only for TDD.

The system information block type 14 contains parameters for common and dedicated physical channel uplink outer loop power control information to be used in both idle and connected mode. The block may also contain scheduling information for other system information blocks.

Information Element/Group name	Need	Multi	Type and reference	Semantics description
Other information elements				
References to other system information blocks	OP		References to other system information blocks 10.3.8.11	Only system information blocks with area scope "Cell" and update mechanism "value tag" may be referenced.
PhyCH information elements				
Individual Timeslot interference list	MP	1 to <maxTS>		
>Individual Timeslot interference	MP		Individual Timeslot interference 10.3.6.37	

10.2.49.8.16 System Information Block type 15

The system information block type 15 contains information useful for LCS. In particular it allows the UE based method to perform localization without dedicated signalling. For the UE assisted methods the signalling is reduced.

Information Element/Group name	Need	Multi	Type and Reference	Semantics description
References to other system information blocks	OP		References to other system information blocks 10.3.8.11	Only system information blocks with area scope "Cell" and update mechanism "value tag" may be referenced.
LCS Cipher GPS Data Indicator	OP		LCS Cipher GPS Data Indicator 10.3.7.43	This is included if the SIB types 15.1, 15.2 & 15.3 are ciphered in accordance with the Data Assistance Ciphering Algorithm specified in [18]
LCS OTDOA assistance for SIB	OP		LCS OTDOA assistance for SIB 10.3.7.61	

10.2.49.8.16.1 System Information Block type 15.1

The system information block type 15.1 contains information useful for LCS DGPS Corrections. The DGPS Corrections message contents are based on a Type-1 message of version 2.2 of the RTCM-SC-104 recommendation for differential service. This format is a standard of the navigation industry and is supported by all DGPS receivers.

Information Element/Group name	Need	Multi	Type and Reference	Semantics description
UTRAN Time Flag	MP		Bitstring(1)	
Node B Clock Drift Flag	MP		Bitstring(1)	
Node B Clock Drift	OP		Real(-0.1..0.1 by a proper step)	This IE provides an estimate of the drift rate of the Node B clock relative to GPS time. It has units of $\mu\text{sec}/\text{sec}$ (ppm) and a range of ± 0.1 . This IE aids the UE in maintaining the relation between GPS and cell timing over a period of time. A positive value for Node B Clock Drift indicates that the Node B clock is running at a greater frequency than desired.
Reference Location	MP		As defined in TS23.032	Provides a prior knowledge of the approximate location of the UE
SFN	OP		Integer(0..4095)	The SFN that occurs at the Reference GPS TOW time
Reference GPS TOW	MP		Integer(0..6047*1011)	GPS Time of Week with scaling factor of 1 usec. This field time-stamps the start of the frame with SFN=0.
Status/Health	MP		Enumerated(UDRE scale 1.0, UDRE scale 0.75, UDRE scale 0.5, UDRE scale 0.3, UDRE scale 0.2, UDRE scale 0.1, no data, invalid data)	This field indicates the status of the differential corrections.
DPGS information	CV-Status	1..<maxSat>		The following fields contain the DPGS corrections. If the Cipher information is included these fields are ciphered.
>SatID	MP		Enumerated (0...63)	The satellite ID number.
>IODE	MP		Integer(0..255)	This IE is the sequence number for the ephemeris for the particular satellite. The MS can use this IE to determine if new ephemeris is used for calculating the corrections that are provided in the broadcast message. This eight-bit IE is incremented for each new set of ephemeris for the satellite and may occupy the numerical range of [0, 239] during normal operations.
>UDRE	MP		Enumerated(UDRE \leq 1.0 m, 1.0m < UDRE \leq	User Differential Range Error. This field provides an estimate of the uncertainty ($1-\sigma$) in the corrections for the particular satellite. The value in this field

Information Element/Group name	Need	Multi	Type and Reference	Semantics description
			UDRE \leq 4.0m, 4.0m < UDRE \leq 8.0m, 8.0m < UDRE)	shall be multiplied by the UDRE Scale Factor in the Status field to determine the final UDRE estimate for the particular satellite.
>PRC	MP		Integer(-2047..2047)	Scaling factor 0.32 meters (different from [13])
>RRC	MP		Integer(-127..127)	Scaling factor 0.032 meters/sec (different from [13])
>Delta PRC2	MP		Integer(-127..127)	The difference in the pseudorange correction between the satellite's ephemeris identified by IODE and the previous ephemeris two issues ago IODE -2.
>Delta RRC2	MP		Integer(-7..7)	The difference in the pseudorange rate-of-change correction between the satellite's ephemeris identified by IODE and IODE-2.

NOTE: Each UDRE value shall be adjusted based on the operation of an Integrity Monitor (IM) function which exists at the network (SRNC, GPS server, or reference GPS receiver itself). Positioning errors derived at the IM which are excessive relative to DGPS expected accuracy levels shall be used to scale the UDRE values to produce consistency.

Condition	Explanation
Status/Health	This IE is mandatory if "status" is not equal to "no data" or "invalid data", otherwise the IE is not needed

10.2.49.8.16.2 System Information Block type 15.2

The system information block type 15.2 contains information useful for ephemeris and clock corrections of a particular satellite. These IE fields are extracted from the subframes 1 to 3 of the GPS navigation message [12].

Information Element/Group name	Need	Multi	Type and Reference	Semantics description
Transmission TOW	MP		Enumerated(0..1048575)	The approximate GPS time-of-week when the message is broadcast
SatID	MP		Enumerated(0..63)	Satellite ID
TLM Message	MP		Bit string(14)	
TLM Revd (C)	MP		Bit string(2)	
HOW	MP		Bit string(22)	
WN	MP		Bit string(10)	
C/A or P on L2	MP		Bit string(2)	
URA Index	MP		Bit string(4)	
SV Health	MP		Bit string(6)	
IODC	MP		Bit string(10(1))	
L2 P Data Flag	MP		Bit string(1)	
SF 1 Reserved	MP		Bit string(87)	
TGD	MP		Bit string(8)	
toc	MP		Bit string(16(1))	
af2	MP		Bit string(8)	
af1	MP		Bit string(16)	
af0	MP		Bit string(22)	
Crs	MP		Bit string(16)	
Δn	MP		Bit string(16)	
M0	MP		Bit string(32)	
Cuc	MP		Bit string(16)	
e	MP		Bit string(32(1))	
Cus	MP		Bit string(16)	
(A)1/2	MP		Bit string(32(1))	
toe	MP		Bit string(16(1))	
Fit Interval Flag	MP		Bit string(1)	
AODO	MP		Bit string(5)	
Cic	MP		Bit string(16)	
OMEGA0	MP		Bit string(32)	
Cis	MP		Bit string(16)	
i0	MP		Bit string(32)	
Crc	MP		Bit string(16)	
ω	MP		Bit string(32)	
OMEGA _{dot}	MP		Bit string(24)	
ldot	MP		Bit string(14)	
Spare/zero fill	MP		Bit string(20)	

10.2.49.8.16.3 System Information Block type 15.3

The system information block type 15.3 contains information useful for ionospheric delay, UTC offset, and Almanac. These IE fields are extracted from the subframes 4 and 5 of the GPS navigation message, excluding the parity bits and other redundant bits [12].

Information Element/Group name	Need	Multi	Type and Reference	Semantics description
Transmission TOW	MP		Enumerated(0..1048575)	The approximate GPS time-of-week when the message is broadcast
SatMask	MP		Bitstring(1..32)	indicates the satellites that contain the pages being broadcast in this data set
LSB TOW	MP		Bit string(8)	
GPS Info	MP	1 to <Max_Dat_rep>		
>SFIO 0	MP		Bit string(1)	Each repetition corresponds to a different page no. as described in the table below
>Data ID	MP		Bit string(2)	
>Page No.	MP		Bit string(6)	
>Word 3	MP		Bit string(16)	
>Word 4	MP		Bit string(24)	
>Word 5	MP		Bit string(24)	
>Word 6	MP		Bit string(24)	
>Word 7	MP		Bit string(24)	
>Word 8	MP		Bit string(24)	
>Word 9	MP		Bit string(24)	
>Word 10	MP		Bit string(22)	
Spare/zero fill	MP		Bit string(5)	

Mapping of Almanac, Health, Iono, and UTC Data to Subframe Number and Page Number

Data Type	Subframe	Page(s)
Almanac Data (SV1 – 24)	5	1 - 24
Almanac Data (SV25 – 32)	4	2, 3, 4, 5, 7, 8, 9, 10
SV Health (SV1 – 24)	5	25
SV Health (SV25 – 32)	4	25
Ionos/UTC Corrections	4	18

Multi Bound	Explanation
Max_Dat_rep	Maximum number of repeats=3

10.2.49.8.17 System Information Block type 16

The system information block type 16 contains radio bearer, transport channel and physical channel parameters to be stored by UE in idle and connected mode for use during handover to UTRAN. The block may also contain scheduling information for other system information blocks.

Information Element/Group name	Need	Multi	Type and Reference	Semantics description
Other information elements				
References to other system information blocks	OP		References to other system information blocks 10.3.8.11	Only system information blocks with area scope "Cell" and update mechanism "value tag" may be referenced.
UE information elements				
Re-establishment timer	MP		Re-establishment timer 10.3.3.29	
RB information elements				
Predefined RB configuration	MP		Predefined RB configuration 10.3.4.7	
TrCH Information Elements				
Predefined TrCH configuration	MP		Predefined TrCH configuration 10.3.5.9	
PhyCH Information Elements				
Predefined PhyCH configuration	MP		Predefined PhyCH configuration 10.3.6.55	

10.2.49.8.18 System Information Block type 17

NOTE: Only for TDD.

The system information block type 17 contains fast changing parameters for the configuration of the shared physical channels to be used in connected mode. The block may also contain scheduling information for other system information blocks.

Information Element/Group name	Need	Multi	Type and reference	Semantics description
References to other system information blocks	OP		References to other system information blocks 10.3.8.11	Only system information blocks with area scope "Cell" and update mechanism "value tag" may be referenced.
PhyCH information elements				
PUSCH system information	OP		PUSCH system information 10.3.6.65	
PDSCH system information	OP		PDSCH system information 10.3.6.45	

10.2.50 SYSTEM INFORMATION CHANGE INDICATION

This message is used to send information on FACH to the UEs in state CELL_FACH about coming modification of the system information.

RLC-SAP: TM

Logical channel: BCCH

Direction: UTRAN → UE

Information Element/Group name	Need	Multi	Type and reference	Semantics description
Message Type	MP		Message Type	
Other information elements				
BCCH modification info	MP		BCCH modification info 10.3.8.1	

If the encoded message does not fill a transport block, the RRC layer shall insert padding according to subclause 12.1.

10.2.51 TRANSPORT CHANNEL RECONFIGURATION

This message is used by UTRAN to configure the transport channel of a UE. This also includes a possible reconfiguration of physical channels. The message can also be used to assign a TFC subset and reconfigure physical channel.

RLC-SAP: AM or UM

Logical channel: DCCH

Direction: UTRAN → UE

Information Element/Group name	Need	Multi	Type and reference	Semantics description
Message Type	MP		Message Type	
UE Information Elements				
<u>RRC transaction identifier</u>	<u>MP</u>		<u>RRC transaction identifier</u> 10.3.3.34a	
Integrity check info	CH		Integrity check info 10.3.3.14	
Integrity protection mode info	OP		Integrity protection mode info 10.3.3.17	
Ciphering mode info	OP		Ciphering mode info 10.3.3.5	
Activation time	MD		Activation time 10.3.3.1	Default value is "now"
New U-RNTI	OP		U-RNTI 10.3.3.45	
New C-RNTI	OP		C-RNTI 10.3.3.8	
<u>DRX Indicator</u> <u>RRC State Indicator</u>	MP		<u>DRX Indicator</u> <u>RR C State Indicator</u> 10.3.3.10	
UTRAN DRX cycle length coefficient	MD		UTRAN DRX cycle length coefficient 10.3.3.47	Default value is the existing value of UTRAN DRX cycle length coefficient
CN Information Elements				
CN Information info	OP		CN Information info 10.3.1.3	
UTRAN mobility information elements				
URA identity	OP		URA identity 10.3.2.6	
RB information elements				
RB with PDCP information list	OP	1 to <maxRBall RABs>		This IE is needed for each RB having PDCP in the case of lossless SRNS relocation
>RB with PDCP information	MP		RB with PDCP information 10.3.4.22	
TrCH Information Elements				
Uplink transport channels				

Information Element/Group name	Need	Multi	Type and reference	Semantics description
UL Transport channel information common for all transport channels	OP		UL Transport channel information common for all transport channels 10.3.5.24	
Added or Reconfigured TrCH information list	MP	1 to <maxTrCH >		
>Added or Reconfigured UL TrCH information	MP		Added or Reconfigured UL TrCH information 10.3.5.2	
CHOICE mode	OP			
>FDD				
>>CPCH set ID	OP		CPCH set ID 10.3.5.3	
>> Added or Reconfigured TrCH information for DRAC list	OP	1 to <maxTrCH >		
>>>DRAC static information	MP		DRAC static information 10.3.5.7	
>TDD				(no data)
Downlink transport channels				
DL Transport channel information common for all transport channels	OP		DL Transport channel information common for all transport channels 10.3.5.6	
Added or Reconfigured TrCH information list	MP	1 to <maxTrCH >		
>Added or Reconfigured DL TrCH information	MP		Added or Reconfigured DL TrCH information 10.3.5.1	
PhyCH information elements				
Frequency info	MD		Frequency info 10.3.6.35	Default value is the existing value of frequency information
Uplink radio resources				
Maximum allowed UL TX power	MD		Maximum allowed UL TX power 10.3.6.38	Default value is the existing maximum UL TX power
CHOICE channel requirement	OP			At least one spare choice (criticality = reject) required
>Uplink DPCH info			Uplink DPCH info 10.3.6.86	
>PRACH Info (for RACH)			PRACH Info (for RACH) 10.3.6.54	
>CPCH SET Info			CPCH SET Info 10.3.6.12	
Downlink radio resources				
CHOICE mode				
>FDD				

Information Element/Group name	Need	Multi	Type and reference	Semantics description
>>Downlink PDSCH information	OP		Downlink PDSCH information 10.3.6.29	
>TDD				(no data)
Downlink information common for all radio links	OP		Downlink information common for all radio links 10.3.6.23	
Downlink information per radio link list	OP	1 to <maxRL>		Send downlink information for each radio link
>Downlink information for each radio link	MP		Downlink information for each radio link 10.3.6.26	

10.2.52 TRANSPORT CHANNEL RECONFIGURATION COMPLETE

This message is sent from the UE when a transport channel reconfiguration has been done.

RLC-SAP: AM

Logical channel: DCCH

Direction: UE → UTRAN

Information Element/Group name	Need	Multi	Type and reference	Semantics description
Message Type	MP		Message Type	
UE information elements				
<u>RRC transaction identifier</u>	<u>MP</u>		<u>RRC transaction identifier</u> 10.3.3.34a	
Integrity check info	CH		Integrity check info 10.3.3.14	
Uplink integrity protection activation info	OP		Integrity protection activation info 10.3.3.15	
CHOICE mode	OP			
>FDD				(no data)
>TDD				
>>Uplink Timing Advance	OP		Uplink Timing Advance 10.3.6.93	This information element shall be present in case of handover procedure if timing advance is enabled. Calculated timing advance value for the new cell after handover in a synchronous TDD network
RB Information elements				
Radio bearer uplink ciphering activation time info	OP		RB activation time info 10.3.4.13	
RB with PDCP information list	OP	1 to <maxRBall RABs>		This IE is needed for each RB having PDCP in the case of lossless SRNS relocation
>RB with PDCP information	MP		RB with PDCP information 10.3.4.22	

10.2.53 TRANSPORT CHANNEL RECONFIGURATION FAILURE

This message is sent by UE if the configuration given by UTRAN is unacceptable or if the UE failed to establish the physical channel(s).

RLC-SAP: AM

Logical channel: DCCH

Direction: UE→UTRAN

Information Element/Group name	Need	Multi	Type and reference	Semantics description
Message Type	MP		Message Type	
UE information elements				
<u>RRC transaction identifier</u>	<u>MP</u>		<u>RRC transaction identifier</u> 10.3.3.34a	
Integrity check info	CH		Integrity check info 10.3.3.14	
Failure cause	MP		Failure cause and error information 10.3.3.12	

10.2.54 TRANSPORT FORMAT COMBINATION CONTROL

This message is sent by UTRAN to control the uplink transport format combination within the allowed transport format combination set.

RLC-SAP: TM, AM or UM

Logical channel: DCCH

Direction: UTRAN→UE

Information Element/Group name	Need	Multi	Type and reference	Semantics description
Message Type	CV-notTM		Message Type	
UE information elements				
<u>RRC transaction identifier</u>	<u>CV-notTMMP</u>		<u>RRC transaction identifier</u> 10.3.3.34a	
Integrity check info	CV-notTM		Integrity check info 10.3.3.14	
TrCH information elements				
CHOICE mode	MP			
>FDD				(no data)
>TDD				
>>TFCS Id	OP		Transport Format Combination Set Identity 10.3.5.21	
DPCH/PUSCH TFCS in uplink	MP		Transport Format Combination subset 10.3.5.22	
TFC Control duration	CV-notTMopt		TFC Control duration 10.3.6.78	

Condition	Explanation
NotTM	The message type is not included when transmitting the message on the transparent mode signalling DCCH
NotTMopt	The information element is not included when transmitting the message on the transparent mode signalling DCCH and is optional otherwise.

If transparent mode signalling is used and the encoded message does not fill a transport block, the RRC layer shall insert padding according to subclause 12.1.

10.2.55 TRANSPORT FORMAT COMBINATION CONTROL FAILURE

This message is sent to indicate that a received TRANSPORT FORMAT COMBINATION CONTROL message could not be handled by the UE.

RLC-SAP: AM

Logical channel: DCCH

Direction: UE→UTRAN

Information Element/Group name	Need	Multi	Type and reference	Semantics description
Message Type	MP		Message Type	
UE information elements				
<u>RRC transaction identifier</u>	<u>MP</u>		<u>RRC transaction identifier</u> 10.3.3.34a	
Integrity check info	CH		Integrity check info 10.3.3.14	
Failure cause	MP		Failure cause and error information 10.3.3.12	

10.2.56 UE CAPABILITY ENQUIRY

The UE CAPABILITY ENQUIRY is used by the UTRAN to enquire inter-system classmarks from the UE.

RLC-SAP: ~~TBD~~AM or UM

Logical channel: DCCH

Direction: UTRAN → UE

Information Element/Group name	Need	Multi	Type and reference	Semantics description
Message Type	MP		Message Type	
UE information elements				
<u>RRC transaction identifier</u>	<u>MP</u>		<u>RRC transaction identifier</u> 10.3.3.34a	
Integrity check info	CH		Integrity check info 10.3.3.14	Integrity check info is included if integrity protection is applied
Capability update requirement	MP		Capability update requirement 10.3.3.2	

10.2.57 UE CAPABILITY INFORMATION

This message is sent by UE to convey UE specific capability information to the UTRAN.

RLC-SAP: AM or UM

Logical channel: DCCH

Direction: UE → UTRAN

Information Element/Group name	Need	Multi	Type and reference	Semantics description
Message Type	MP		Message Type	
UE information elements				
<u>RRC transaction identifier</u>	<u>OP</u>		<u>RRC transaction identifier</u> 10.3.3.34a	
Integrity check info	CH		Integrity check info 10.3.3.14	Integrity check info is included if integrity protection is applied
UE radio access capability	OP		UE radio access capability 10.3.3.40	
Other information elements				
UE system specific capability	OP		Inter-system message 10.3.8.6	Includes inter-system classmark

10.2.58 UE CAPABILITY INFORMATION CONFIRM

This message is sent by UTRAN to confirm that UE capability information has been received.

RLC-SAP: AM or UM

Logical channel: DCCH

Direction: UTRAN → UE

Information Element/Group name	Need	Multi	Type and reference	Semantics description
Message Type	MP		Message Type	
UE information elements				
<u>RRC transaction identifier</u>	<u>MP</u>		<u>RRC transaction identifier</u> 10.3.3.34a	
Integrity check info	CH		Integrity check info 10.3.3.14	Integrity check info is included if integrity protection is applied

10.2.59 UPLINK DIRECT TRANSFER

This message is used to transfer NAS messages for an on-going signalling flow.

RLC-SAP: AM

Logical channel: DCCH

Direction: UE →UTRAN

Information Element/Group name	Need	Multi	Type and reference	Semantics description
Message Type	MP		Message Type	
UE information elements				
Integrity check info	CH		Integrity check info 10.3.3.14	Integrity check info is included if integrity protection is applied
CN information elements				
Flow Identifier	MP		Flow Identifier 10.3.1.4	Allocated by UE for a particular flow
NAS message	MP		NAS message 10.3.1.8	
Measurement information elements				
Measured results on RACH	OP		Measured results on RACH 10.3.7.70	

10.2.60 UPLINK PHYSICAL CHANNEL CONTROL

NOTE: Only for TDD.

~~In TDD this~~ This message is used to transfer uplink physical channel parameters to the UE.

RLC-SAP: AM or UM

Logical channel: DCCH

Direction: UTRAN→UE

Information Element/Group name	Need	Multi	Type and Reference	Semantics description
Message Type	MP		Message Type	
UE information elements				
<u>RRC transaction identifier</u>	<u>MP</u>		<u>RRC transaction identifier</u> 10.3.3.34a	
Integrity check info	OP		Integrity check info 10.3.3.14	
PhyCH information elements				
CCTrCH power control info	OP		CCTrCH power control info 10.3.6.7	Power control information for one CCTrCH
Timing Advance Control	OP		UL Timing Advance Control 10.3.6.94	
PRACH Constant Value	OP		Constant value 10.3.6.10	Operator controlled PRACH Margin
PUSCH Constant Value	OP		Constant value 10.3.6.10	Operator controlled PUSCH Margin

10.2.61 URA UPDATE

This message is used by the UE to initiate a URA update procedure.

RLC-SAP: TM

Logical channel: CCCH

Direction: UE→UTRAN

Information Element/Group name	Need	Multi	Type and reference	Semantics description
Message Type	MP		Message Type	
UE information elements				
U-RNTI	MP		U-RNTI 10.3.3.45	
RRC transaction identifier	CV- ProtErr		RRC transaction identifier 10.3.3.34a	
Integrity check info	CH		Integrity check info 10.3.3.14	
URA update cause	MP		URA update cause 10.3.3.44	
Protocol error indicator	MD		Protocol error indicator 10.3.3.27	Default value is FALSE
Other information elements				
Protocol error information	CV-ProtErr		Protocol error information 10.3.8.10	

Condition	Explanation
ProtErr	If the IE "Protocol error indicator" has the value "TRUE"

10.2.62 URA UPDATE CONFIRM

This message confirms the URA update procedure and can be used to reallocate new RNTI information for the UE valid after the URA update.

RLC-SAP: UM

Logical channel: CCCH or DCCH

Direction: UTRAN→UE

Information Element/Group name	Need	Multi	Type and reference	Semantics description
Message Type	MP		Message Type	
UE information elements				
U-RNTI	CV-CCCH		U-RNTI 10.3.3.45	
<u>RRC transaction identifier</u>	<u>MP</u>		<u>RRC transaction identifier</u> 10.3.3.34a	
Integrity check info	CH		Integrity check info 10.3.3.14	Integrity check info is included if integrity protection is applied
Integrity protection mode info	OP		Integrity protection mode info 10.3.3.17	
Ciphering mode info	OP		Ciphering mode info 10.3.3.5	
New U-RNTI	OP		U-RNTI 10.3.3.45	
New C-RNTI	OP		C-RNTI 10.3.3.8	
<u>DRX Indicator</u> <u>RRC State Indicator</u>	MP		<u>DRX Indicator</u> <u>RR C State Indicator</u> 10.3.3.10	
UTRAN DRX cycle length coefficient	MD		UTRAN DRX cycle length coefficient 10.3.3.47	Default value is the existing value of UTRAN DRX cycle length coefficient
CN Information Elements				
CN Information info	OP		CN Information info 10.3.1.3	
UTRAN mobility information elements				
URA identity	OP		URA identity 10.3.2.6	
RB information elements				
RB with PDCP information list	OP	1 to <maxRBall RABs>		This IE is needed for each RB having PDCP in the case of lossless SRNS relocation
>RB with PDCP information	MP		RB with PDCP information 10.3.4.22	

Condition	Explanation
CCCH	This IE is only sent when CCCH is used

10.2.63 UTRAN MOBILITY INFORMATION

This message is used by UTRAN to allocate a new RNTI and to convey other UTRAN mobility related information to a UE.

RLC-SAP: AM or UM

Logical channel: DCCH

Direction: UTRAN→UE

Information Element/Group name	Need	Multi	Type and reference	Semantics description
Message Type	MP		Message Type	
UE Information Elements				
Integrity check info	CH		Integrity check info 10.3.3.14	
<u>RRC transaction identifier</u>	<u>MP</u>		<u>RRC transaction identifier</u> 10.3.3.34a	
Integrity protection mode info	OP		Integrity protection mode info 10.3.3.17	
Ciphering mode info	OP		Ciphering mode info 10.3.3.5	
New U-RNTI	OP		U-RNTI 10.3.3.45	
New C-RNTI	OP		C-RNTI 10.3.3.8	
<u>DRX Indicator</u> <u>RRC State Indicator</u>	MP		<u>DRX Indicator</u> <u>RR C State Indicator</u> 10.3.3.10	
UTRAN-DRX cycle length coefficient	MD		UTRAN-DRX cycle length coefficient 10.3.3.47	Default value is the existing value of UTRAN-DRX cycle length coefficient
CN Information Elements				
CN Information info	OP		CN Information info 10.3.1.3	
UTRAN Information Elements				
URA identity	OP		URA identity 10.3.2.6	
RB Information elements				
RB with PDCP information list	OP	1 to <maxRBall RABs>		This IE is needed for each RB having PDCP in the case of lossless SRNS relocation
>RB with PDCP information	MP		RB with PDCP information 10.3.4.22	

10.2.64 UTRAN MOBILITY INFORMATION CONFIRM

This message is used to confirm the new UTRAN mobility information for the UE.

RLC-SAP: AM

Logical channel: DCCH

Direction: UE→UTRAN

Information Element/Group name	Need	Multi	Type and reference	Semantics description
Message Type	MP		Message Type	
UE information elements				
<u>RRC transaction identifier</u>	<u>MP</u>		<u>RRC transaction identifier</u> 10.3.3.34a	
Integrity check info	CH		Integrity check info 10.3.3.14	
Uplink integrity protection activation info	OP		Integrity protection activation info 10.3.3.15	
RB Information elements				
Radio bearer uplink ciphering activation time info	OP		RB activation time info 10.3.4.13	
RB with PDCP information list	OP	1 to <maxRBall RABs>		This IE is needed for each RB having PDCP in the case of lossless SRNS relocation
>RB with PDCP information	MP		RB with PDCP information 10.3.4.22	

10.2.65 UTRAN MOBILITY INFORMATION FAILURE

This message is sent to indicate a failure to act on a received UTRAN MOBILITY INFORMATION message.

RLC-SAP: AM

Logical channel: DCCH

Direction: UE→UTRAN

Information Element/Group name	Need	Multi	Type and reference	Semantics description
Message Type	MP		Message Type	
UE information elements				
<u>RRC transaction identifier</u>	<u>MP</u>		<u>RRC transaction identifier</u> 10.3.3.34a	
Integrity check info	CH		Integrity check info 10.3.3.14	
Failure cause	MP		Failure cause and error information 10.3.3.12	

10.3 Information element functional definitions

10.3.1 CN Information elements

10.3.1.1 CN domain identity

Identifies the type of core network domain.

Information Element/Group name	Need	Multi	Type and reference	Semantics description
CN domain identity	MP		Enumerated (CS domain, PS domain, Don't care)	At least 1 spare value needed Criticality: criticality reject is needed

10.3.1.2 CN Domain System Information

Information Element/Group name	Need	Multi	Type and reference	Semantics description
CN domain identity	MP		CN domain identity 10.3.1.1	
CHOICE CN Type	MP			
>GSM-MAP				
>>CN domain specific NAS system information	MP		NAS system information (GSM-MAP) 10.3.1.9	
>ANSI-41				
>>CN domain specific NAS system information	MP		ANSI-41 NAS system information, 10.3.9.4	
CN domain specific DRX cycle length coefficient	MP		CN domain specific DRX cycle length coefficient, 10.3.3.6	

10.3.1.3 CN Information info

Information Element/Group name	Need	Multi	Type and reference	Semantics description
PLMN identity	OP		PLMN identity 10.3.1.11	
CN common GSM-MAP NAS system information	OP		NAS system information (GSM-MAP) 10.3.1.9	
CN domain related information	OP	1 to <maxCNdomains>		
>CN domain identity	MP		CN domain identity 10.3.1.1	
>CN domain specific GSM-MAP NAS system info	MP		NAS system information (GSM-MAP) 10.3.1.9	

NOTE 1: Necessity of PLMN is FFS and for CN domain identity and NAS system information, the confirmation in SA WG2 is needed.

10.3.1.4 Flow Identifier

This IE is allocated by the UE for a particular signalling flow on an indication from the upper layers.

Information Element/Group name	Need	Multi	Type and reference	Semantics description
Flow Identifier	MP		Integer (0..63)	

10.3.1.5 IMEI

This IE contains an International Mobile Equipment Identity. Setting specified in [TS 23.003]

Information Element/Group name	Need	Multi	Type and reference	Semantics description
IMEI	MP	15		
>IMEI digit	MP		INTEGER(0..15)	

10.3.1.6 IMSI (GSM-MAP)

This IE contains an International Mobile Subscriber Identity, used towards a GSM-MAP type of PLMN. Setting specified in [TS 23.003]

Information Element/Group name	Need	Multi	Type and reference	Semantics description
IMSI	MP	6 to 15		
>IMSI digit	MP		INTEGER(0..9)	

10.3.1.7 Location Area Identification

Identifies uniquely a location area for a GSM-MAP type of PLMN. Setting specified in [TS24.008].

Information Element/Group name	Need	Multi	Type and reference	Semantics description
PLMN identity	MP		PLMN identity 10.3.1.11	
LAC	MP		Bit string(16)	

10.3.1.8 NAS message

A non-access stratum message to be transferred transparently through UTRAN.

Information Element/Group name	Need	Multi	Type and reference	Semantics description
NAS message	MP		Octet string (1..4095)	

10.3.1.9 NAS system information (GSM-MAP)

This information element contains system information that belongs to the non-access stratum for a GSM-MAP type of PLMN. This information is transparent to RRC. It may contain either information specific to one CN domain (CS or PS) or information common for both CN domains.

Information Element/Group name	Need	Multi	Type and reference	Semantics description
GSM-MAP NAS system information	MP		Octet string(1..8)	

10.3.1.10 Paging record Type identifier

Information Element/Group name	Need	Multi	Type and reference	Semantics description
Paging Record Type Identifier	MP		Enumerated (IMSI (GSM-MAP), TMSI (GSM-MAP)/P-TMSI, IMSI (DS-41), TMSI (DS-41))	

10.3.1.11 PLMN identity

This information element identifies a Public Land Mobile Network for a GSM-MAP type of PLMN. Setting of digits is defined in [TS 23.003].

Information Element/Group name	Need	Multi	Type and reference	Semantics description
MCC	MP	3		
>MCC digit	MP		INTEGER(0..9)	
MNC	MP	2 to 3		
>MNC digit	MP		INTEGER(0..9)	

10.3.1.12 PLMN Type

Identifies the type of Public Land Mobile Network (PLMN). This IE shall be used to control the interpretation of network dependent messages and information elements in the RRC protocol.

Information Element/Group name	Need	Multi	Type and reference	Semantics description
PLMN Type	MP		Enumerated (GSM-MAP, ANSI-41, GSM-MAP and ANSI-41)	At least 1 spare value needed Criticality: reject is needed

10.3.1.13 P-TMSI (GSM-MAP)

This IE contains a Packet Temporary Mobile Subscriber Identity, used towards a GSM-MAP type of PLMN.

Information Element/Group name	Need	Multi	Type and reference	Semantics description
P-TMSI	MP		Bit string (32)	Setting specified in [TS 23.003]

10.3.1.14 RAB identity

This information element uniquely identifies a radio access bearer within a CN domain.

Information Element/Group name	Need	Multi	Type and reference	Semantics description
CHOICE RAB identity type	MP			
>RAB identity (GSM-MAP)			Bit string (8)	Formatted according to [TS 24.008].
>RAB identity (ANSI-41)			Bit string (8)	

CHOICE NAS binding info type	Condition under which the given RAB identity type is chosen
RAB identity (GSM-MAP)	PLMN is of type GSM-MAP
RAB identity (ANSI-41)	PLMN is of type ANSI-41

10.3.1.15 Routing Area Code

Identifies a routing area within a location area for a GSM-MAP type of PLMN.

Information Element/Group name	Need	Multi	Type and reference	Semantics description
Routing Area Code	MP		Bit string(8)	Setting specified in [TS 23.003]

10.3.1.16 Routing Area Identification

Identifies uniquely a routing area for a GSM-MAP type of PLMN. Setting specified in [TS 23.003].

Information Element/Group name	Need	Multi	Type and reference	Semantics description
LAI	MP		Location area identification 10.3.1.7	
RAC	MP		Routing area code 10.3.1.15	

10.3.1.17 Service Descriptor

Identifies a service and/or a protocol entity in the core network.

Information Element/Group name	Need	Multi	Type and reference	Semantics description
CHOICE Service descriptor type	MP			
>Service Descriptor (GSM-MAP)			Bit string (4)	Protocol Discriminator [TS 24.007] The value of RR in the above reference is reserved for paging response.
>Service Descriptor (ANSI-41)			Bit string(4)	TIA/EIA IS-834

CHOICE Service descriptor type	Condition under which the given Service descriptor type is chosen
Service descriptor (GSM-MAP)	PLMN is of type GSM-MAP
Service descriptor (ANSI-41)	PLMN is of type ANSI-41

10.3.1.18 TMSI (GSM-MAP)

This IE contains a Temporary Mobile Subscriber Identity, used towards a GSM-MAP type of PLMN.

Information Element/Group name	Need	Multi	Type and reference	Semantics description
TMSI (GSM-MAP)	MP		Bit string (32)	Setting specified in [TS 23.003]

10.3.2 UTRAN mobility Information elements

10.3.2.1 Cell Access Restriction

Indicates the restrictions to cell access.

Information Element/Group name	Need	Multi	Type and reference	Semantics description
Cell Barred	MP		Enumerated(not barred, barred)	
Intra-frequency cell re-selection indicator	CV-Barred		Enumerated(not allowed, allowed)	
Tbarred	CV-Barred		Integer (10,20,40,80,160,320,640,1280)	[4] (TS25.304)
Cell Reserved for operator use	MP		Enumerated(reserved, not reserved)	
Cell Reserved for SoLSA exclusive use	MP		Enumerated(reserved, not reserved)	
Access Class Barred list	MD	maxAC		Default is no access class barred is applied. The first instance of the parameter corresponds to Access Class 0, the second to Access Class 1 and so on up to Access Class 15. UE reads this IE of its access class stored in SIM.
>Access Class Barred	MP		Enumerated(not barred, barred)	

Condition	Explanation
Barred	Presence is mandatory if the IE "Cell Barred" has the value "Barred"; otherwise the element is not needed in the message.

10.3.2.2 Cell identity

This information element identifies a cell unambiguously within a PLMN.

Information Element/Group name	Need	Multi	Type and reference	Semantics description
Cell identity	MP		bit string(28)	

10.3.2.3 Cell selection and re-selection info for SIB3/4

Information Element/Group name	Need	Multi	Type and reference	Semantics description
Mapping Info	MD		Mapping info 10.3.2.5	Contains mapping function for quality measurements. Default is an implicit mapping: Qmap = Qmeas,LEV, TS 25.304.
Cell_selection_and_reselection_quality_measure	MP		Enumerated (CPICH Ec/N0, CPICH RSCP)	Choice of measurement (CPICH Ec/N0 or CPICH RSCP) to use as quality measure Q for FDD cells.
CHOICE mode	MP			
>FDD				
>>Sintrasearch	OP		Integer (-32..20 by step of 2)	TS 25.304 [dB]
>>Sintersearch	OP		Integer (-32..20 by step of 2)	TS 25.304 [dB]
>>SsearchHCS	OP		Integer (-105..91 by step of 2)	TS 25.304 [dB]
>>RAT List	OP	1 to <maxOther RAT>		
>>>RAT identifier	MP		Enumerated (GSM, cdma2000)	At least 2 spare values Criticality: reject are needed
>>>Ssearch,RAT	MP		Integer (-105..91 by step of 2)	TS 25.304 [dB]
>>>SHCS,RAT	OP		Integer (-32..20 by step of 2)	TS 25.304 [dB]
>>Slimit,ShearchRAT	OP		Integer (-32..20 by step of 2)	TS 25.304 [dB]
>TDD				
>>Sintrasearch	OP		Integer (-105..91 by step of 2)	TS 25.304 [dB]

>>Sintersearch	OP		Integer (-105..91 by step of 2)	TS 25.304 [dB]
>>SsearchHCS	OP		Integer (-105..91 by step of 2)	TS 25.304 [dB]
>>RAT List	OP	1 to <maxOther RAT>		
>>>RAT identifier	MP		Enumerated (GSM, cdma2000)	At least 2 spare values Criticality: reject are needed
>>>Ssearch,RAT	OP		Integer (-105..91 by step of 2)	TS 25.304 [dB]
>>>SHCS,RAT	OP		Integer (-105..91 by step of 2)	TS 25.304 [dB]
>>>Slimit,ShearchRAT	OP		Integer (-105..91 by step of 2)	TS 25.304 [dB]
Qhyst1s	MP		Integer (0..40 by step of 2)	TS 25.304
Qhyst2s	CV-FDD-Quality-Measure		Integer (0..40 by step of 2)	Default value is Qhyst1s TS 25.304
Treselections	MP		Integer (0..31)	[s]
HCS Serving cell Information	OP		HCS Serving cell information 10.3.7.12	
Maximum allowed UL TX power	MP		Maximum allowed UL TX power 10.3.6.38	[dBm] UE_TXPWR_MAX_RACH in 25.304.
CHOICE mode	MP			
>FDD				
>>Qqualmin	MP		Integer (-20..0)	Ec/N0, [dB]
>>>Qrxlevmin	MP		Integer (-115..-25 by step of 2)	RSCP, [dBm]
>TDD				
>>Qrxlevmin	MP		Integer (-115..-25 by step of 2)	RSCP, [dBm]

Condition	Explanation
CV-FDD-Quality-Measure	Presence is not allowed if the IE "Cell_selection_and_reselection_quality_measure" has the value CPICH RSCP, otherwise the IE is mandatory and has a default value.

10.3.2.4 Cell selection and re-selection info for SIB11/12

Information Element/Group name	Need	Multi	Type and reference	Semantics description
Qoffset1s,n	MD		Real(-50.0..50.0 by step of 1)	Default value is 0.
Qoffset2s,n	CV-FDD-Quality-Measure		Real(-50.0..50.0 by step of 1)	Default value is 0.
Maximum allowed UL TX power	MD		Maximum allowed UL TX power 10.3.6.38	[dBm] UE_TXPWR_MAX_RACH in 25.304. Default is the Maximum allowed UL TX power for the serving cell
HCS neighbouring cell information	OP		HCS Neighbouring cell information 10.3.7.11	
CHOICE mode	MP			
>FDD				
>>Qqualmin	MD		Integer (-20..0)	Ec/N0, [dB] Default value is Qqualmin for the serving cell
>>Qrxlevmin	MD		Integer (-115..-25 by step of 2)	RSCP, [dBm] Default value is Qrxlevmin for the serving cell
>TDD				
>>Qrxlevmin	MD		Integer (-115..-25 by step of 2)	RSCP, [dBm] Default value is Qrxlevmin for the serving cell

Condition	Explanation
FDD-Quality-Measure	Presence is not allowed if the IE "Cell_selection_and_reselection_quality_measure" has the value CPICH RSCP, otherwise the IE is mandatory and has a default value.

10.3.2.5 Mapping Info

Information Element/Group name	Need	Multi	Type and Reference	Semantics description
Mapping List	MP	1 to <MaxRAT>		
>RAT	MP		Enumerated (UTRA FDD, UTRA TDD, GSM, cdma2000)	
>Mapping Function Parameter List	MP	1 to <maxMeas Intervals>		
>> Function type	MP		Enumerated (linear, function type 2, function type 3, function type 4)	Type of the function within the interval.
>>Map_parameter_1	MD		Integer (0..99)	Parameter describing the mapping function between the quality measurement and the representing quality value, see TS 25.304. Default value is zero for the first interval or otherwise the value of Map_parameter_2 of the interval before.
>>Map_parameter_2	MP		Integer (0..99)	Parameter describing the mapping function between the quality measurement and the representing quality value, see TS 25.304.
>>Upper_limit	CV - MaxInt		Integer (1..MaxMeas)	Upper limit of interval for which the Map_parameter_1 and Map_parameter_2 are valid. MaxMeas = 25 if RAT = UTRA FDD / CPICH Ec/N0, MaxMeas = 91 if RAT = UTRA TDD or if RAT = UTRA FDD/ CPICH RSCP, MaxMeas = 63 if RAT = GSM.

Condition	Explanation
MaxInt	This information is only sent if Mapping Function Parameter List has not reached maxMeasIntervals.

10.3.2.6 URA identity

Gives the identity of the UTRAN Registration Area. It can be used to indicate to the UE which URA it shall use in case of overlapping URAs.

Information Element/Group name	Need	Multi	Type and reference	Semantics description
URA identity	MP		bit string(16)	

10.3.3 UE Information elements

10.3.3.1 Activation time

Activation Time defines the frame number/time at which the operation/changes caused by the related message shall be executed. Values between 0 and 255 indicate the absolute value of CFN (Connection Frame Number) of that frame number/time.

Information Element/Group name	Need	Multi	Type and reference	Semantics description
Activation time	MP		Integer(0..255, Now)	CFN [TS 25.402]

10.3.3.2 Capability Update Requirement

This IE indicates to the UE which specific capabilities to transfer to the network.

Information Element/Group name	Need	Multi	Type and reference	Semantics description
UE radio access capability update requirement	MP		Boolean	TRUE indicates update required
System specific capability update requirement list	OP	1 to <maxSystemCapability>		
>System specific capability update requirement	MP		Enumerated (GSM)	At least 15 spare values Criticality: reject are needed

Default value is:

"UE radio capability update requirement" = false

"System specific capability update requirement" not present.

10.3.3.3 Cell update cause

Indicates the cause for cell update.

Information Element/Group name	Need	Multi	Type and reference	Semantics description
Cell update cause	MP		Enumerated (cell reselection, periodic cell update, UL uplink data transmission, paging response, RB control response, re-entered service area, RLC unrecoverable error)	At least 2 spare values, Criticality: reject, are needed

10.3.3.4 Cipherring Algorithm

Information Element/Group name	Need	Multi	Type and reference	Semantics description
Cipherring algorithm	MP		Enumerated (UEA0, UEA1)	14 spare values needed. Criticality: criticality reject is needed.

10.3.3.5 Cipherring mode info

This information element contains the cipherring specific security mode control information.

Information Element/Group name	Need	Multi	Type and reference	Semantics description
Cipherring mode command	MP		Enumerated (start/restart, stop)	
Cipherring algorithm	CV-notStop		Cipherring algorithm 10.3.3.4	
Activation time for DPCH	OP		Activation time 10.3.3.1	Used for radio bearers mapped on RLC-TM
Radio bearer downlink cipherring activation time info	OP		RB activation time info, 10.3.4.13	Used for radio bearers mapped on RLC-AM or RLC-UM

Condition	Explanation
notStop	The IE is mandatory if the IE "Cipherring mode command" has the value "start/restart", otherwise the IE is not needed in the message.

10.3.3.6 CN domain specific DRX cycle length coefficient

A coefficient in the formula to count the paging occasions to be used by a specific UE (specified in 25.304).

Information Element/Group name	Need	Multi	Type and reference	Semantics description
CN domain specific DRX cycle length coefficient	MP		Integer(6...12)	Refers to 'k' in the formula as specified in 25.304, Discontinuous reception

10.3.3.7 CPCH Parameters

NOTE: Only for FDD.

These parameters are used by any UE using any CPCH set allocated to the cell that is broadcasting this system information.

Information Element/Group name	Need	Multi	Type and reference	Semantics description
Initial Priority Delay	OP	1 to maxASC		Initial delays for ASC priority.
>NS_IP	MP		Integer (0...28)	Number of slots for initial fixed delay for each ASC priority level
Backoff control parameters	MP			
>N_ap_retrans_max	MP		Integer (1...64)	Max number of AP transmissions without AP-AICH response, a PHY parameter.
>N_access_fails	MP		Integer (1...64)	Max number of preamble ramping cycles when NAK response received, a MAC parameter.
>NF_bo_no_aich	MP		Integer (0...31)	Number of frames for UE backoff after N ap_retrans_max unsuccessful AP access attempts, a MAC parameter.
>NS_bo_busy	MP		Integer (0...63)	Number of slots for UE fixed backoff after access attempt to busy CPCH, a MAC parameter.
>NF_bo_all_busy	MP		Integer (0...31)	Max number of frames for UE backoff after access attempt to last busy CPCH, a MAC parameter. UE randomly selects backoff value from range (0..NF_bo_all_busy)
>NF_bo_mismatch	MP		Integer (0...127)	Max number of frames for the UE backoff after received mismatch on CD/CA-ICH, a MAC parameter. UE randomly selects backoff value from range (0..NF_bo_mismatch)
>T_CPCH	MP		Enumerated (0, 1)	CPCH channel timing used to determine Tau, a PHY parameter
Power Control Algorithm	MP		Enumerated (algorithm 1, algorithm 2)	Specifies algorithm to be used by UE to interpret TPC commands
TPC step size	CV algo		Integer (1, 2)	In dB
DL DPCCH BER	MP		Integer (0..63)	The BER quality value shall be set in the range $0 \leq \text{DPCCH BER} \leq 1$ in the unit BER_dB where: BER_dB_0: DPCCH BER = 0 BER_dB_1: $-\infty < \text{Log}_{10}(\text{DPCCH BER}) < -4.03$ BER_dB_2: $-4.03 \leq \text{Log}_{10}(\text{DPCCH BER}) < -3.965$ BER_dB_3: $-3.965 \leq \text{Log}_{10}(\text{DPCCH BER}) < -3.9$... BER_dB_61: $-0.195 \leq \text{Log}_{10}(\text{DPCCH BER}) < -0.13$

				BER_dB_62: $-0.13 \leq \text{Log}_{10}(\text{DPCCH BER}) < -0.065$ BER_dB_63: $-0.065 \leq \text{Log}_{10}(\text{DPCCH BER}) \leq 0$
--	--	--	--	---

Condition	Explanation
algo	The IE is mandatory if "Power Control Algorithm" is set to "algorithm 1", otherwise the IE is not needed

10.3.3.8 C-RNTI

The cell RNTI (C-RNTI) identifies an UE having a RRC connection within a cell.

Information Element/Group name	Need	Multi	Type and reference	Semantics description
C-RNTI	MP		bit string(16)	

10.3.3.9 DRAC system information

Information element	Need	Multi	Type and reference	Semantics description
DRAC system information	MP	1 to <maxDRA Cclasses>		DRAC information is sent for each class of terminal
>Transmission probability	MP		Transmission probability 10.3.3.37	
>Maximum bit rate	MP		Maximum bit rate 10.3.3.19	

10.3.3.10 DRX Indicator/RRC State Indicator

Indicates to a UE if DRX shall be used with Cell updating or URA updating or if no DRX at all shall be used.

Information Element/Group name	Need	Multi	Type and reference	Semantics description
DRX indicator/RRC State Indicator	MP		Enumerated(<u>cell-dch</u> , <u>cell-fach</u> , <u>cell-pch</u> , <u>URA-pch</u> CELL DCH, CELL FACH, CELL PCH, URA PCH, DRX, DRX with cell updating, DRX with URA updating)	At least 1 spare value, Criticality: reject, are needed

10.3.3.11 Establishment cause

Cause for an RRC connection establishment request.

Information Element/Group name	Need	Multi	Type and reference	Semantics description
Establishment cause	MP		Enumerated(Originating Conversational Call, Originating Streaming Call, Originating Interactive Call, Originating Background Call, Originating Subscribed traffic Call, Terminating Conversational Call, Terminating Streaming Call, Terminating Interactive Call, Terminating Background Call, Emergency Call, Inter-system cell re-selection, Registration, Detach, SMS, Call re-establishment)	At least 17 spare values, Criticality: reject, are needed

NOTE: These causes shall be aligned with causes received from higher layers.

10.3.3.11a Failure cause

Cause for failure to perform the requested procedure.

<u>Information Element/Group name</u>	<u>Need</u>	<u>Multi</u>	<u>Type and reference</u>	<u>Semantics description</u>
<u>Failure cause</u>	<u>MP</u>		<u>Enumerated (configuration unsupported, physical channel failure, incompatible simultaneous reconfiguration, protocol error, compressed mode runtime error, cell reselection, invalid configuration)</u>	<u>At least 3 spare values, Criticality: reject, are needed</u>

10.3.3.12 Failure cause and error information

Cause for failure to perform the requested procedure and diagnostics information.

<u>Information Element/Group name</u>	<u>Need</u>	<u>Multi</u>	<u>Type and reference</u>	<u>Semantics description</u>
<u>Failure cause</u>	<u>MP</u>		<u>Enumerated (Configuration unsupported, physical channel failure, incompatible simultaneous reconfiguration, protocol error), compressed mode runtime error) Failure cause 10.3.3.11a</u>	<u>At least 3 spare values, Criticality: reject, are needed</u>
<u>Protocol error information</u>	<u>CV-ProtErr</u>		<u>Protocol error information 10.3.8.10</u>	
<u>Deleted TGPSI</u>	<u>CV-CompModeErr</u>		<u>TGPSI 10.3.6.80</u>	

<u>Condition</u>	<u>Explanation</u>
<u>ProtErr</u>	<u>Presence is mandatory if the IE "Failure cause" has the value "Protocol error"; otherwise the element is not needed in the message.</u>
<u>CompModeErr</u>	<u>Presence is mandatory if the IE "Failure cause" has the value "Compressed mode runtime error"; otherwise the element is not needed in the message</u>

10.3.3.13 Initial UE identity

This information element identifies the UE at a request of an RRC connection.

Information Element/Group name	Need	Multi	Type and reference	Semantics description
CHOICE UE id type	MP			At least 8 spare choices, Criticality: reject, is needed
>IMSI (GSM-MAP)			IMSI (GSM-MAP) 10.3.1.6	
>TMSI and LAI (GSM-MAP)				
>>TMSI (GSM-MAP)	MP		TMSI (GSM-MAP) 10.3.1.18	
>>LAI (GSM-MAP)	MP		Location Area Identification 10.3.1.7	
>P-TMSI and RAI (GSM-MAP)				
>>P-TMSI (GSM-MAP)	MP		P-TMSI (GSM-MAP) 10.3.1.13	
>>RAI (GSM-MAP)	MP		Routing Area Identification 10.3.1.16	
>IMEI			IMEI 10.3.1.5	
>ESN (DS-41)			TIA/EIA/IS-2000-4	
>IMSI (DS-41)			TIA/EIA/IS-2000-4	
>IMSI and ESN (DS-41)			TIA/EIA/IS-2000-4	
>TMSI (DS-41)			TIA/EIA/IS-2000-4	

10.3.3.14 Integrity check info

The Integrity check info contains the RRC message sequence number needed in the calculation of XMAC-I [TS 33.102] and the calculated MAC-I.

Information Element/Group name	Need	Multi	Type and reference	Semantics description
Message authentication code	MP		bit string(32)	MAC-I [TS 33.102] The 27 MSB of the IE shall be set to zero and the 5 LSB of the IE shall be set to the used signalling radio bearer identity when the encoded RRC message is used as the MESSAGE parameter in the integrity protection algorithm.
RRC Message sequence number	MP		Integer (0..15)	The local RRC hyper frame number (RRC HFN) is concatenated with the RRC message sequence number to form the input parameter COUNT-I for the integrity protection algorithm. The IE value shall be set to zero when the encoded RRC message is used as the MESSAGE parameter in the integrity protection algorithm.

10.3.3.15 Integrity protection activation info

This IE contains the time, in terms of RRC sequence numbers, when a new integrity protection configuration shall be activated for the signalling radio bearers.

Information Element/Group name	Need	Multi	Type and reference	Semantics description
RRC message sequence number list	MP	4 to 5		The RRC sequence number when a new integrity protection configuration shall be applied, for CCCH (=RB0) and signalling radio bearers in the order RB0, RB1, RB2, RB3, RB4.
>RRC message sequence number	MP		Integer (0..15)	

10.3.3.16 Integrity protection Algorithm

Information Element/Group name	Need	Multi	Type and reference	Semantics description
Integrity protection algorithm	MP		Enumerated (UIA1)	15 spare values needed. Criticality: criticality reject is needed.

10.3.3.17 Integrity protection mode info

Information Element/Group name	Need	Multi	Type and reference	Semantics description
Integrity protection mode command	MP		Enumerated (start, modify)	At least 2 spare values, Criticality: reject, are needed
Downlink integrity protection activation info	CV-modify		Integrity protection activation info 10.3.3.15	
Integrity protection algorithm	OP		Integrity protection algorithm 10.3.3.16	
Integrity protection initialization number	CV-start		Bitstring(32)	FRESH [TS 33.102]

Condition	Explanation
Start	The IE is mandatory if the IE "Integrity protection mode command" has the value "start", otherwise it is not needed in the message.
Modify	The IE is only present if the IE "Integrity protection mode command" has the value "modify"

10.3.3.18 LCS capability

Information Element/Group name	Need	Multi	Type and reference	Semantics description
Standalone location method(s) supported	MP		Boolean	Defines if a UE can measure its location by some means unrelated to UTRAN TRUE means supported
UE based OTDOA supported	MP		Boolean	TRUE means supported
Network Assisted GPS support	MP		Enumerated ('Network based', 'UE based', 'Both', 'None')	Defines if the UE supports network based or UE based GPS methods.
GPS reference time capable	MP		Boolean	Defines if a UE has the capability to measure GPS reference time as defined in 25.215. TRUE means capable
Support for IPDL	MP		Boolean	Defines if a UE has the capability to use IPDL to enhance its 'SFN-SFN observed time difference –type 2' measurement. TRUE means supported

10.3.3.19 Maximum bit rate

NOTE: Only for FDD.

Indicates the maximum user bit rate allowed on a DCH controlled by DRAC procedure for the transmission period (Transmission time validity).

Information Element/Group name	Need	Multi	Type and reference	Semantics description
Maximum bit rate	MP		integer(0..512 by step of 16)	=kbit/s

10.3.3.20 Measurement capability

Information Element/Group name	Need	Multi	Type and reference	Semantics description
Need for downlink compressed mode				
FDD measurements DL	MP		Boolean	TRUE means that the UE requires DL compressed mode in order to perform measurements on FDD
TDD measurements DL	CV tdd_sup		Boolean	TRUE means that the UE requires DL compressed mode in order to perform measurements on TDD
GSM measurements DL	CV gsm_sup			
> GSM 900 DL	MP		Boolean	TRUE means that the UE requires DL compressed mode in order to perform measurements on GSM 900
> DCS 1800 DL	MP		Boolean	TRUE means that the UE requires DL compressed mode in order to perform measurements on DCS 1800
> GSM 1900 DL	MP		Boolean	TRUE means that the UE requires DL compressed mode in order to perform measurements on GSM 1900
Multi-carrier measurement DL	CV mc_sup		Boolean	TRUE means that the UE requires DL compressed mode in order to perform measurements on multi-carrier
Need for uplink compressed mode				
FDD measurements UL	MP		Boolean	TRUE means that the UE requires UL compressed mode in order to perform measurements on FDD
TDD measurements UL	CV tdd_sup		Boolean	TRUE means that the UE requires UL compressed mode in order to perform measurements on TDD
GSM measurements UL	CV gsm_sup			
> GSM 900 UL	MP		Boolean	TRUE means that the UE requires UL compressed mode in order to perform measurements on GSM 900
> DCS 1800 UL	MP		Boolean	TRUE means that the UE requires UL compressed mode in order to perform measurements on DCS 1800
> GSM 1900 UL	MP		Boolean	TRUE means that the UE requires UL compressed mode in order to perform measurements on GSM 1900
Multi-carrier measurement UL	CV mc_sup		Boolean	TRUE means that the UE requires UL compressed mode in order to perform measurements on multi-carrier

Condition	Explanation
tdd_sup	Presence is mandatory if IE Multi-mode capability = TDD. Otherwise this field is not needed in the message.
gsm_sup	Presence is mandatory if IE Multi-RAT capability = GSM. Otherwise this field is not needed in the message.
mc_sup	Presence is mandatory if IE Multi-RAT capability = multi-carrier. Otherwise this field is not needed in the message.

10.3.3.21 Number of RRC Message Transmissions

This IE indicates how many times the receiver of a message containing this IE shall transmit the RRC response message.

Information Element/Group name	Need	Multi	Type and reference	Semantics description
Number of RRC Message Transmissions	MP		Integer(1..8)	

10.3.3.22 Paging cause

Cause for a CN originated page.

Information Element/Group name	Need	Multi	Type and reference	Semantics description
Paging cause	MP		Enumerated(Terminating Conversational Call, Terminating Streaming Call, Terminating Interactive Call, Terminating Background Call, SMS)	At least 3 spare values, Criticality: reject, are needed

NOTE: These causes shall be aligned with causes received from higher layers.

10.3.3.23 Paging record

Information Element/Group name	Need	Multi	Type and reference	Semantics description
CHOICE paging originator	MP			
> CN originator				
>> Paging cause	MP		Paging cause 10.3.3.22	
>> CN domain identity	MP		CN domain identity 10.3.1.1	
>>CHOICE UE Identity	MP			At least 3 spare choice, Criticality: reject, are needed
>>>IMSI (GSM-MAP)			IMSI (GSM-MAP) 10.3.1.6	
>>>TMSI (GSM-MAP)			TMSI (GSM-MAP) 10.3.1.18	
>>>P-TMSI (GSM-MAP)			P-TMSI (GSM-MAP) 10.3.1.13	
>>>IMSI (DS-41)			TIA/EIA/IS-2000-4	
>>>TMSI (DS-41)			TIA/EIA/IS-2000-4	
> UTRAN originator				
>>U-RNTI	MP		U-RNTI 10.3.3.45	

Condition	Explanation
CHOICE Paging originator	Condition under which the given paging originator is chosen
CN Originating	For CN originating pages (idle mode)
UTRAN Originating	For UTRAN originating pages (connected mode)

10.3.3.24 PDCCP capability

Indicates which algorithms and which value range of their parameters are supported by the UE.

Information Element/Group name	Need	Multi	Type and reference	Semantics description
Support for lossless SRNS relocation	MP		Boolean	TRUE means supported
Support for RFC2507	MP		Boolean	TRUE means supported
Max HC context space	CV-hc_sup		Integer(512, 1024, 2048, 4096, 8192)	Maximum header compression context space in bytes supported by the UE At least 3 spare values needed, criticality: reject

Condition	Explanation
hc_sup	Presence is mandatory if IE Support for RFC 2507 = TRUE. Otherwise this field is not needed in the message

10.3.3.25 Physical channel capability

Information Element/Group name	Need	Multi	Type and Reference	Semantics description
Downlink physical channel capability information elements				
CHOICE mode	MP			
>FDD				
>>Maximum number of simultaneous CCTrCH	MP		Integer (1..8)	
>> Max no DPCH/PDSCH codes	MP		Integer (1..8)	Maximum number of DPCH/PDSCH codes to be simultaneously received
>> Max no physical channel bits received	MP		Integer (600, 1200, 2400, 3600, 4800, 7200, 9600, 14400, 19200, 28800, 38400, 48000, 57600, 67200, 76800)	Maximum number of physical channel bits received in any 10 ms interval (DPCH, PDSCH, S-CCPCH) At least 1 spare values needed
>>Support for SF 512	MP		Boolean	TRUE means supported
>>Support of PDSCH	MP		Boolean	TRUE means supported
>>Simultaneous reception of SCCPCH and DPCH	MP		Boolean	TRUE means supported
>>Simultaneous reception of SCCPCH, DPCH and PDSCH	CV-if_sim_rec_pdsch_sup		Boolean	TRUE means supported
>>Max no of S-CCPCH RL	CV-if_sim_rec		Integer(1)	Maximum number of simultaneous S-CCPCH radio links At least 7 spare values needed.
>TDD				
>>Maximum number of simultaneous CCTrCH	MP		Integer (1..8)	
>>Maximum number of timeslots per frame	MP		Integer (1..14)	At least 2 spare values needed.
>>Maximum number of physical channels per frame	MP		Integer (1..224)	At least 32 spare values needed
>>Minimum SF	MP		Integer (1, 16)	
>>Support of PDSCH	MP		Boolean	TRUE means supported
>>Maximum number of physical channels per timeslot	MP		Integer (1..16)	
Uplink physical channel capability information elements				
CHOICE mode	MP			
>FDD				
>>Maximum number of DPDCH bits transmitted per 10 ms	MP		Integer (600, 1200, 2400, 4800, 9600, 19200, 28800, 38400, 48000, 57600)	At least 6 spare values needed
>>Support of PCPCH	MP		Boolean	TRUE means supported
>TDD				
>>Maximum number of simultaneous CCTrCH	MP		Integer (1..8)	
>>Maximum Number of	MP		Integer	At least 2 spare values needed

timeslots per frame			(1..14)	
>>Maximum number of physical channels per timeslot	MP		Integer (1, 2)	
>>Minimum SF	MP		Integer (1, 2, 4, 8, 16)	At least 3 spare values needed
>>Support of PUSCH	MP		Boolean	TRUE means supported

Condition	Explanation
if_sim_rec_pdsch_sup	Presence is mandatory if IE Simultaneous reception of SCCPCH and DPCH = True and IE Support of PDSCH = True. Otherwise this field is not needed in the message.
if_sim_rec	Presence is mandatory if IE capability Simultaneous reception of SCCPCH and DPCH = True. Otherwise this field is not needed in the message.

10.3.3.26 Protocol error cause

This IE indicates the cause for a message or information which was not comprehended.

Information Element/Group name	Need	Multi	Type and reference	Semantics description
Protocol error cause	MP		Enumerated (ASN.1 violation or encoding error, Message type non-existent or not implemented, Message not compatible with receiver state, Information element value not comprehended, Conditional information element error, Message extension not comprehended)	At least 2 spare values are needed.

10.3.3.27 Protocol error indicator

This IE indicates whether a message was transmitted due to a protocol error or not.

Information Element/Group name	Need	Multi	Type and Reference	Semantics description
Protocol error indicator	MP		Boolean	TRUE means a protocol error occurred. FALSE means a protocol error did not occur.

10.3.3.28 Redirection info

This IE is used to redirect the UE to another frequency or other system.

Information Element/Group name	Need	Multi	Type and reference	Semantics description
CHOICE Redirection Information	MP			At least one spare choice, Criticality: reject, is needed.
>Frequency info			Frequency info 10.3.6.35	
>Inter-system info			Inter-system info 10.3.7.25	

10.3.3.29 Re-establishment timer

This information element indicates which timer to associate with RAB. SRBs are associated with T314. IE "T314 value" and IE "T315 value" are used to update timer value stored in the UE. The value of timers shall not be updated in UE locally by decoding SYSTEM INFORMATION during connected mode.

Information Element/Group name	Need	Multi	Type and reference	Semantics description
Re-establishment timer	MP		Enumerated(useT314, useT315)	
CHOICE Timer value	MP			
>T314				
>>T314 value	OP		Integer(0, 2, 4, 6, 8, 12, 16, 20)	
>T315				
>>T315 value	OP		Integer(0, 10, 30, 60, 180, 600, 1200, 1800)	

10.3.3.30 Rejection cause

Cause for rejection of RRC connection establishment request.

Information Element/Group name	Need	Multi	Type and reference	Semantics description
Rejection cause	MP		Enumerated(congestion, unspecified)	At least 2 spare values, Criticality: reject, are needed

10.3.3.31 Release cause

Cause for release of RRC connection.

Information Element/Group name	Need	Multi	Type and reference	Semantics description
Release cause	MP		Enumerated (normal event, unspecified, pre-emptive release, congestion, re-establishment reject, user inactivity), directed signalling connection re-establishment)	At least 9 spare values, Criticality: reject, are needed

10.3.3.32 RF capability

Information Element/Group name	Need	Multi	Type and Reference	Semantics description
CHOICE mode	MP			
>FDD				
>>UE power class	MP		Enumerated(1..4)	as defined in 25.101 subclause 6.2.1
>>Tx/Rx frequency separation	MP		Enumerated(190, 174.8-205.2, 134.8-245.2)	In MHz as defined in 25.101 subclause 5.3. NOTE: Not applicable if UE is not operating in frequency band a (as defined in 25.101). At least 1 spare value needed
>TDD				
>>UE power class	MP		Enumerated (1..4)	as defined in 25.102 subclause 6.2.1
>>Radio frequency bands	MP	1 to <maxFrequencybands >	Enumerated(a, b, c)	as defined in 25.102 subclause 5.2 At least 1 spare value needed
>>Chip rate capability	MP		Enumerated(3.84Mcps, 1.28Mcps)	as defined in 25.102

10.3.3.33 RLC capability

Information Element/Group name	Need	Multi	Type and Reference	Semantics description
Total RLC AM buffer size	MP		Integer (2,10,50,100,150,500,1000)	Total receiving and transmitting RLC AM buffer capability in kBytes At least 1 spare value needed
Maximum RLC AM Window Size	MP		Integer(2047,4095)	Maximum supported RLC TX and RX window in UE
Maximum number of AM entities	MP		Integer (3,4,5,6,8,16,32)	At least 1 spare value needed

10.3.3.34a RRC transaction identifier

This IE contains an identification of the RRC procedure transaction local for the type of the message this IE was included within.

Information Element/Group name	Need	Multi	Type and reference	Semantics description
RRC transaction identifier	MP		Integer (0..3)	

10.3.3.34 RLC reset indicator

This IE is used to re-configure AM RLC on c-plane and u-plane.

Information Element/Group name	Need	Multi	Type and reference	Semantics description
RLC reset indicator	MP		Boolean	TRUE means reset required FALSE means reset not required

10.3.3.35 Security capability

Information Element/Group name	Need	Multi	Type and reference	Semantics description
Ciphering algorithm capability	MP		Bit string(16)	"00000000000000012": UEA0, no encryption supported; "0000000000000102": UEA1, Kasumi supported
Integrity protection algorithm capability	MP		Bit string(16)	"0000000000000102": UIA1, Kasumi supported

NOTE: Each bit is 0 or 1 to indicate support for the corresponding UEAx or UIAx, x=0 to 15. The UE shall support at least one UEAx other than UEA0 and one UIAx. The ciphering algorithm capability bit for UEA0 indicates to UTRAN if the UE accepts unciphered connection(s) after the security mode control procedure.

10.3.3.36 START

There is a START value per CN domain. The START the 20 MSBs of all hyper frame numbers (MAC-d HFN, RLC UM HFN, RLC AM HFN, RRC HFN) for a CN domain.

Information Element/Group name	Need	Multi	Type and Reference	Semantics description
START	MP		Bit string (20)	[TS 33.102]

10.3.3.37 Transmission probability

NOTE: Only for FDD.

Indicates the probability for a mobile to be allowed to transmit on a DCH controlled by DRAC procedure.

Information Element/Group name	Need	Multi	Type and reference	Semantics description
Transmission probability	MP		Real(0.125.. 1.0 by step of 0.125)	probability

10.3.3.38 Transport channel capability

Information Element/Group name	Need	Multi	Type and Reference	Semantics description
Downlink transport channel capability information elements				
Max no of bits received	MP		Integer(640, 1280, 2560, 3840, 5120, 6400, 7680, 8960, 10240, 20480, 40960, 81920, 163840)	Maximum sum of number of bits of all transport blocks received in TTIs that end within the same arbitrary interval of length T<10 ms At least 3 spare values are needed.
Max convolutionally coded bits received	MP		Integer(640, 1280, 2560, 3840, 5120, 6400, 7680, 8960, 10240, 20480, 40960, 81920, 163840)	Maximum sum of number of bits of all convolutionally coded transport blocks received in TTIs that end within the same arbitrary interval of length T<10 ms At least 3 spare values are needed
Max turbo coded bits received	CV turbo_dec_sup		Integer(640, 1280, 2560, 3840, 5120, 6400, 7680, 8960, 10240, 20480, 40960, 81920, 163840)	Maximum sum of number of bits of all turbo coded transport blocks received in TTIs that end within the same arbitrary interval of length T<10 ms At least 3 spare values are needed
Maximum number of simultaneous transport channels	MP		Integer(4, 8, 16, 32)	
Max no of received transport blocks	MP		Integer(4, 8, 16, 32, 48, 64, 96, 128, 256, 512)	Maximum total number of transport blocks received within TTIs that end at within the same 10ms interval At least 6 spare values needed
Maximum number of TFC in the TFCS	MP		Integer(16, 32, 48, 64, 96, 128, 256, 512, 1024)	At least 7 spare values needed
Maximum number of TF	MP		Integer(32, 64, 128, 256, 512, 1024)	At least 2 spare values needed
Support for turbo decoding	MP		Boolean	TRUE means supported
Uplink transport channel capability information elements				
Max no of bits transmitted	MP		Integer(640, 1280, 2560, 3840, 5120, 6400, 7680, 8960, 10240, 20480, 40960, 81920, 163840)	Maximum sum of number of bits of all transport blocks transmitted in TTIs that start at the same time At least 3 spare values needed
Max convolutionally coded bits transmitted	MP		Integer(640, 1280, 2560, 3840, 5120, 6400, 7680, 8960, 10240, 20480, 40960, 81920,	Maximum sum of number of bits of all convolutionally coded transport blocks transmitted in TTIs that start at the same time At least 3 spare values needed

Max turbo coded bits transmitted	CV turbo_enc_ sup		163840) Integer(640, 1280, 2560, 3840, 5120, 6400, 7680, 8960, 10240, 20480, 40960, 81920, 163840)	Maximum sum of number of bits of all turbo coded transport blocks transmitted in TTIs that start at the same time At least 3 spare values needed
Maximum number of simultaneous transport channels	MP		Integer(2, 4, 8, 16, 32)	At least 3 spare values needed
Max no of transmitted transport blocks	MP		Integer(2, 4, 8, 16, 32, 48, 64, 96, 128, 256, 512)	Maximum total number of transport blocks transmitted within TTIs that start at the same time At least 5 spare values needed
Maximum number of TFC in the TFCS	MP		Integer(4, 8, 16, 32, 48, 64, 96, 128, 256, 512, 1024)	At least 5 spare values needed
Maximum number of TF	MP		Integer(32, 64, 128, 256, 512, 1024)	At least 2 spare values needed
Support for turbo encoding	MP		Boolean	TRUE means supported

Condition	Explanation
turbo_dec_sup	Presence is mandatory if IE Support of turbo decoding = True. Otherwise this field is not needed in the message.
turbo_enc_sup	Presence is mandatory if IE Support of turbo encoding = True. Otherwise this field is not needed in the message.

10.3.3.39 UE multi-mode/multi-RAT capability

Information Element/Group name	Need	Multi	Type and Reference	Semantics description
Multi-RAT capability				
Support of GSM	MP		Boolean	
Support of multi-carrier	MP		Boolean	
Multi-mode capability	MP		Enumerated (TDD, FDD, FDD/TDD)	

10.3.3.40 UE radio access capability

Information Element/Group name	Need	Multi	Type and reference	Semantics description
ICS version	MP		Enumerated(R99)	Indicates the release version of TS 34.123-2 (Implementation Conformance Statement (ICS) proforma specification) that is applicable for the UE.. At least 7 spare values needed
PDCP capability	MP		PDCP capability 10.3.3.24	
RLC capability	MP		RLC capability 10.3.3.33	
Transport channel capability	MP		Transport channel capability 10.3.3.38	
RF capability	MP		RF capability 10.3.3.32	
Physical channel capability	MP		Physical channel capability 10.3.3.25	
UE multi-mode/multi-RAT capability	MP		UE multi-mode/multi-RAT capability 10.3.3.39	
Security capability	MP		Security capability 10.3.3.35	
LCS capability	MP		LCS capability 10.3.3.18	
CHOICE mode	MP			
>FDD				
>>Measurement capability	MP		Measurement capability 10.3.3.20	
>TDD				(no data)

10.3.3.41 UE Timers and Constants in CELL_DCH

This information element specifies timer- and constant values used by the UE in state CELL_DCH.

Information Element/Group name	Need	Multi	Type and reference	Semantics description
T304	MD		Integer(100, 200, 400, 1000, 2000)	Value in milliseconds. Default value is 2000. At least 3 spare values are needed Criticality: reject is needed
N304	MD		Integer(0..7)	Default value is 2.
T308	MD		Integer(40, 80, 160, 320)	Value in milliseconds. Default value is 160.
T309	MD		Integer(1..8)	Value in seconds. Default value is 5.
T310	MD		Integer(40 .. 320 by step of 40)	Value in milliseconds. Default value is 160
N310	MD		Integer(0 .. 7)	Default value is 4
T311	MD		Integer(250 .. 2000 by step of 250)	Value in milliseconds. Default value is 2000
T313	MD		Integer (0..15)	Value in seconds. Default value is 3.
N313	MD		Integer (1, 2, 4, 10, 20, 50, 100, 200)	Default value is 20.
T314	MD		Integer (2,4,6,8,12, 16,20)	Value in seconds. Default value is 12.
T315	MD		Integer (0,10, 30, 60, 180, 600, 1200, 1800)	Value in seconds. Default value is 180.
N315	MD		Integer (1, 50, 100, 200, 400, 600, 800, 1000)	Default value is 1.

10.3.3.42 UE Timers and Constants in connected mode

This information element specifies timer- and constants values used by the UE in connected mode.

Information Element/Group name	Need	Multi	Type and reference	Semantics description
T301	MD		Integer(100, 200 .. 2000 by step of 200, 3000, 4000, 6000, 8000)	Value in milliseconds. Default value is 2000.
N301	MD		Integer(0..7)	Default value is 2.
T302	MD		Integer(100, 200... 2000 by step of 200, 3000, 4000, 6000, 8000)	Value in milliseconds. Default value is 4000.
N302	MD		Integer(0..7)	Default value is 3.
T303	MD		Integer(100, 200... 2000 by step of 200, 3000, 4000, 6000, 8000)	Value in milliseconds. Default value is 2000.
N303	MD		Integer(0..7)	Default value is 3.
T304	MD		Integer(100, 200, 400, 1000, 2000)	Value in milliseconds. Default value is the actual value of the equivalent parameter in IE "UE timers and Constants in CELL_DCH" received within SIB1. Note 1. At least 3 spare values are needed Criticality: reject is needed
N304	MD		Integer(0..7)	Default value is the actual value of the equivalent parameter in IE "UE timers and Constants in CELL_DCH" received within SIB1. Note 1.
T305	MD		Integer(5, 10, 30, 60, 120, 360, 720, infinity)	Value in minutes. Default value is 30. Infinity means no update
T306	MD		Integer(5, 10, 30, 60, 120, 360, 720, infinity)	Value in minutes. Default value is 30. Infinity means no update
T307	MD		Integer(5, 10, 15, 20, 30, 40, 50)	Value in seconds. Default value is 30. At least 1 spare value needed Criticality: reject is needed
T308	MD		Integer(40, 80, 160, 320)	Value in milliseconds. Default value is the actual value of the equivalent parameter in IE "UE timers and Constants in CELL_DCH" received within SIB1. Note 1.
T309	MD		Integer(1...8)	Value in seconds. Default value is the actual value of the

				equivalent parameter in IE "UE timers and Constants in CELL_DCH" received within SIB1. Note 1.
T310	MD		Integer(40 .. 320 by step of 40)	Value in milliseconds. Default value is the actual value of the equivalent parameter in IE "UE timers and Constants in CELL_DCH" received within SIB1. Note 1.
N310	MD		Integer(0 .. 7)	Default value is the actual value of the equivalent parameter in IE "UE timers and Constants in CELL_DCH" received within SIB1. Note 1.
T311	MD		Integer(250 .. 2000 by step of 250)	Value in milliseconds. Default value is the actual value of the equivalent parameter in IE "UE timers and Constants in CELL_DCH" received within SIB1. Note 1.
T312	MD		Integer (0..15)	Value in seconds. Default value is 1.
N312	MD		Integer (1, 50, 100, 200, 400, 600, 800, 1000)	Default value is 1.
T313	MD		Integer (0..15)	Value in seconds. Default value is the actual value of the equivalent parameter in IE "UE timers and Constants in CELL_DCH" received within SIB1. Note 1.
N313	MD		Integer (1, 2, 4, 10, 20, 50, 100, 200)	Default value is the actual value of the equivalent parameter in IE "UE timers and Constants in CELL_DCH" received within SIB1. Note 1.
T314	MD		Integer(0, 2, 4, 6, 8, 12, 16, 20)	Value in seconds. Default value is the actual value of the equivalent parameter in IE "UE timers and Constants in CELL_DCH" received within SIB1. Note 1.
T315	MD		Integer (0,10, 30, 60, 180, 600, 1200, 1800)	Value in seconds. Default value is the actual value of the equivalent parameter in IE "UE timers and Constants in CELL_DCH" received within SIB1. Note 1.
N315	MD		Integer (1, 50, 100, 200, 400, 600, 800, 1000)	Default value is the actual value of the equivalent parameter in IE "UE timers and Constants in CELL_DCH" received within SIB1. Note 1.
<u>T316</u>	<u>MD</u>		<u>Integer(0, 10, 20, 30, 40, 50, infinity)</u>	<u>Value in seconds. Default value is XX.</u> <u>At least 1 spare value needed</u> <u>Criticality: reject is needed</u>
<u>T317</u>	<u>MD</u>		<u>Integer (0,10, 30, 60, 180, 600, 1200, 1800)</u>	<u>Value in seconds</u> <u>Default value is XX</u>

NOTE 1: If the value of SIB1 changes, the UE shall re-read SIB1 and use the new value of the parameter, if modified.

10.3.3.43 UE Timers and Constants in idle mode

This information element specifies timer- and constant values used by the UE in idle mode.

Information Element/Group name	Need	Multi	Type and reference	Semantics description
T300	MP		Integer(10 0, 200... 2000 by step of 200, 3000, 4000, 6000, 8000)	Value in milliseconds
N300	MP		Integer(0.. 7)	
T312	MP		Integer(0 .. 15)	Value in seconds
N312	MP		Integer (1, 50, 100, 200, 400, 600, 800, 1000)	

10.3.3.44 URA update cause

Indicates the cause for s URA update.

Information Element/Group name	Need	Multi	Type and reference	Semantics description
URA update cause	MP		Enumerated(cha nge of URA, periodic URA update, re- entered service area)	At least 5 spare values Criticality: reject, are needed

10.3.3.45 U-RNTI

The U-RNTI (UTRAN Radio Network Temporary Identity) is allocated to an UE having a RRC connection and identifies the UE within UTRAN.

Information Element/Group name	Need	Multi	Type and reference	Semantics description
SRNC identity	MP		bit string(12)	
S-RNTI	MP		bit string(20)	

10.3.3.46 U-RNTI Short

The U-RNTI (UTRAN Radio Network Temporary Identity) is allocated to an UE having a RRC connection and identifies the UE within UTRAN.

Information Element/Group name	Need	Multi	Type and reference	Semantics description
SRNC identity	MP		bit string(12)	
S-RNTI 2	MP		bit string(10)	

10.3.3.47 UTRAN DRX cycle length coefficient

A coefficient in the formula to count the paging occasions to be used by a specific UE (specified in 25.304).

Information Element/Group name	Need	Multi	Type and reference	Semantics description
DRX cycle length coefficient	MP		Integer(3..12)	Refers to 'k' in the formula as specified in 25.304, Discontinuous reception

10.3.3.48 Wait time

Wait time defines the time period the UE has to wait before repeating the rejected procedure.

Information Element/Group name	Need	Multi	Type and reference	Semantics description
Wait time	MP		Integer(0..15)	Wait time in seconds The value 0 indicates that repetition is not allowed.

10.3.4 Radio Bearer Information elements

10.3.4.1 Downlink RLC STATUS info

Information Element/Group name	Need	Multi	Type and reference	Semantics description
Timer_Status_Prohibit	OP		Integer(10..50 by step of 10)	Minimum time in ms between STATUS reports At least 16 spare values with criticality reject is needed
Timer_EPC	OP		Integer(50, 60, 70, 80, 90, 100, 120, 140, 160, 180, 200, 300, 400, 500, 700, 900)	Time in ms At least 16 spare values with criticality reject is needed
Missing PU Indicator	MP		Boolean	Value true indicates that UE should send a STATUS report for each missing PU that is detected
Timer_STATUS_periodic	OP		Integer(100, 200, 300, 400, 500, 750, 1000, 2000)	Time in milliseconds

10.3.4.2 PDCP info

The purpose of the PDCP info IE is to indicate which algorithms shall be established and to configure the parameters of each of the algorithms.

Information Element/Group name	Need	Multi	Type and reference	Semantics description
Support for lossless SRNS relocation	CV-LosslessCriteria		Boolean	TRUE means support
Max PDCP SN	CV Lossless		Integer (255, 65535)	Maximum PDCP sequence number. Default value is 65535.
PDCP PDU header	MD		Enumerated (present, absent)	Whether a PDCP PDU header is existent or not. Default value is "present"
Header compression information	OP	1 to <maxPDCPAlgoType >		
>CHOICE algorithm type	MP			7 spare values needed, criticality: reject
>>RFC2507				Header compression according to IETF standard RFC2507
>>>F_MAX_PERIOD	MD		Integer (1..65535)	Largest number of compressed non-TCP headers that may be sent without sending a full header. Default value is 256.
>>>F_MAX_TIME	MD		Integer (1..255)	Compressed headers may not be sent more than F_MAX_TIME seconds after sending last full header. Default value is 5.
>>>MAX_HEADER	MD		Integer (60..65535)	The largest header size in octets that may be compressed. Default value is 168.
>>>TCP_SPACE	MD		Integer (3..255)	Maximum CID value for TCP connections. Default value is 15.
>>>NON_TCP_SPACE	MD		Integer (3..65535)	Maximum CID value for non-TCP connections. Default value is 15.
>>>EXPECT_REORDERING	MD		Enumerated (reordering not expected, reordering expected)	Whether the algorithm shall reorder PDCP SDUs or not. Default value is "reordering not expected".

Condition	Explanation
LosslessCriteria	This IE is present only if the IE "RLC mode" is "Acknowledged" and the IE "In-sequence delivery" is "True".
Lossless	This IE shall be present if the IE "Support for lossless SRNS relocation" is TRUE, otherwise it shall be absent.

10.3.4.3 PDCP SN info

Information Element/Group name	Need	Multi	Type and Reference	Semantics description
Receive PDCP sequence number	MP		Integer(0..65535)	The PDCP sequence number which the sender of the message is expecting next to be received.

10.3.4.4 Polling info

Information Element/Group name	Need	Multi	Type and reference	Semantics description
Timer_poll_prohibit	OP		Integer(50, 60, 70, 80, 90, 100, 120, 140, 160, 180, 200, 300, 400, 500, 700, 900)	Minimum time between polls in ms 16 spare values needed, criticality: reject
Timer_poll	OP		Integer(10..50 by step of 10, 600..1000 by step of 50)	Time in ms. 16 spare values needed, criticality: reject
Poll_PU	OP		Integer(1,2,4,8,16,32,64,128)	Number of PUs, interval between pollings 8 spare values needed, criticality: reject
Poll_SDU	OP		Integer(1,4,16,64)	Number of SDUs, interval between pollings 4 spare values needed, criticality: reject
Last transmission PU poll	MP		Boolean	TRUE indicates that poll is made at last PU in transmission buffer
Last retransmission PU poll	MP		Boolean	TRUE indicates that poll is made at last PU in retransmission buffer
Poll_Window	OP		Integer(50,60,70,80,85,90,95,99)	Percentage of transmission window, threshold for polling 8 spare values needed, criticality: reject
Timer_poll_periodic	OP		Integer(100, 200, 300, 400, 500, 750, 1000, 2000)	Time in milliseconds Timer for periodic polling. 8 spare values needed, criticality: reject

10.3.4.5 Predefined configuration identity

This information element identifies a pre- defined radio parameter configuration.

Information Element/Group name	Need	Multi	Type and reference	Semantics description
Predefined radio configuration identity	MP		Integer (0..15)	

10.3.4.6 Predefined configuration value tag

This information element is used to identify different versions of a radio bearer configuration as may be used within one PLMN e.g. to support different UTRAN implementations.

Information Element/Group name	Need	Multi	Type and Reference	Semantics description
Predefined configuration value tag	MP		Integer(0..15)	

10.3.4.7 Predefined RB configuration

This information element concerns a pre- defined configuration of radio bearer parameters

Information Element/Group name	Need	Multi	Type and Reference	Semantics description
Signalling radio bearer information				
Signalling RB information to setup List	MP	1 to <maxSRBsetups>		For each signalling radio bearer
>Signalling RB information to setup	MP		Signalling RB information to setup 10.3.4.24	
RB information				Only one RAB supported
RB information to setup list	MP	1 to <maxRBcount>		
>RB information to setup	MP		RB information to setup 10.3.4.20	

10.3.4.8 RAB info

This IE contains information used to uniquely identify a radio access bearer.

Information Element/Group name	Need	Multi	Type and reference	Semantics description
RAB identity	MP		RAB identity 10.3.1.14	
CN domain identity	MP		CN domain identity 10.3.1.1	
RAB NAS Synchronization Indicator	OP		RAB NAS Synchronization info 10.3.4.12	
Re-establishment timer	MP		Re-establishment timer 10.3.3.29	

10.3.4.9 RAB info short

This IE contains information used to uniquely identify a radio access bearer.

Information Element/Group name	Need	Multi	Type and reference	Semantics description
RAB identity	MP		RAB identity 10.3.1.14	
CN domain identity	MP		CN domain identity 10.3.1.1	

10.3.4.10 RAB information for setup

Information Element/Group name	Need	Multi	Type and reference	Semantics description
RAB info	MP		RAB info 10.3.4.8	
RB information to setup list	MP	1 to <maxRBpe rRAB>		
>RB information to setup	MP		RB information to setup 10.3.4.20	

10.3.4.11 RAB information to reconfigure

Information Element/Group name	Need	Multi	Type and reference	Semantics description
RAB identity	MP		RAB Identity 10.3.1.14	
RAB NAS synchronization indicator	MP		RAB NAS Synchronizat ion info 10.3.4.12	

10.3.4.12 RAB NAS Synchronization info

This IE contains information used to uniquely identify a radio access bearer.

Information Element/Group name	Need	Multi	Type and reference	Semantics description
NAS Synchronization info	MP		Bitstring(4)	

10.3.4.13 RB activation time info

This IE contains the time, in terms of RLC sequence numbers, when a certain configuration shall be activated, for a number of radio bearers.

Information Element/Group name	Need	Multi	Type and reference	Semantics description
Radio bearer activation time	OP	1 to <maxRB>		
>RB identity	MP		RB identity 10.3.4.16	
>RLC sequence number	MP		Integer (0.. 4095)	RLC SN [TS 25.322]

10.3.4.14 RB COUNT-C MSB information

The MSB of the COUNT-C values of the radio bearer.

Information Element/Group name	Needed	Multi	Type and reference	Semantics description
RB identity	MP		RB identity 10.3.4.16	
COUNT-C-MSB-uplink	MP		Integer (0.. 2 ²⁵ -1)	25 MSBs from COUNT-C associated to this RB
COUNT-C-MSB-downlink	MP		Integer (0.. 2 ²⁵ -1)	25 MSBs from COUNT-C associated to this RB

10.3.4.15 RB COUNT-C information

The COUNT-C values of the radio bearer.

Information Element/Group name	Needed	Multi	Type and reference	Semantics description
RB identity	MP		RB identity 10.3.4.16	
COUNT-C-uplink	MP		Integer (0.. 2 ³² -1)	
COUNT-C-downlink	MP		Integer (0.. 2 ³² -1)	

10.3.4.16 RB identity

An identification number for the radio bearer affected by a certain message.

Information Element/Group name	Need	Multi	Type and reference	Semantics description
RB identity	MP		Integer(0..31 (1..32))	Values 0 ₁₋₄ shall only be used for signalling radio bearers

10.3.4.17 RB information to be affected

Information Element/Group name	Need	Multi	Type and reference	Semantics description
RB identity	MP		RB identity 10.3.4.16	
RB mapping info	MP		RB mapping info 10.3.4.21	

10.3.4.18 RB information to reconfigure

Information Element/Group name	Need	Multi	Type and reference	Semantics description
RB identity	MP		RB identity 10.3.4.16	
PDCP info	OP		PDCP info 10.3.4.2	
PDCP SN info	C PDCP		PDCP SN info 10.3.4.3	PDCP sequence number info from the network. Present only in case of lossless SRNS relocation.
CHOICE RLC info type >RLC info	OP		RLC info 10.3.4.23	
RB mapping info	OP		RB mapping info 10.3.4.21	
RB suspend/resume	OP		Enumerated(suspend, resume)	

Condition	Explanation
PDCP	This IE is optional only if "PDCP info" is present. Otherwise it is absent.

10.3.4.19 RB information to release

Information Element/Group name	Need	Multi	Type and reference	Semantics description
RB identity	MP		RB identity 10.3.4.16	

10.3.4.20 RB information to setup

Information Element/Group name	Need	Multi	Type and reference	Semantics description
RB identity	MP		RB identity 10.3.4.16	
PDCP info	OP		PDCP info 10.3.4.2	
RLC info	MP		RLC info 10.3.4.23	
RB mapping info	MP		RB mapping info 10.3.4.21	

Multi Bound	Explanation
MaxSetupRBcount	The maximum number of RBs to setup.

NOTE This information element is included within IE "Predefined RB configuration"

10.3.4.21 RB mapping info

A multiplexing option for each possible transport channel this RB can be multiplexed on.

Information Element/Group name	Need	Multi	Type and reference	Semantics description
Information for each multiplexing option	MP	1 to <maxRBMUXOptions>		
>RLC logical channel mapping indicator	CV-UL-RLCLogicalChannels		Boolean	TRUE indicates that the first logical channel shall be used for data PDUs and the second logical channel shall be used for control PDUs. FALSE indicates that control and data PDUs can be sent on either of the two logical channels.
>Number of uplink RLC logical channels	CV-UL-RLC info	1 to MaxLoCHperRLC		1 or 2 logical channels per RLC entity or radio bearer RLC [TS 25.322]
>>Uplink transport channel type	MP		Enumerated(DCH,RACH,CPCH,USCH)	CPCH is FDD only USCH is TDD only
>>ULTransport channel identity	CV-UL-DCH/USCH		Transport channel identity 10.3.5.18	This is the ID of a DCH or USCH (TDD only) that this RB could be mapped onto.
>>Logical channel identity	OP		Integer(1..15)	This parameter is used to distinguish logical channels multiplexed by MAC on a transport channel.
>>MAC logical channel priority	MP		Integer(1..8)	This is priority between a user's different RBs (or logical channels). [25.321]
>>Logical channel max loss	MD		Integer(0,5,10,15,20,25,30,35,40,45,50,55,60,65,70,75,80,85,90,95,100)	[see 25.321]. Default value is 0.
>Number of downlink RLC logical channels	CV-DL-RLC info	1 to MaxLoCHperRLC		1 or 2 logical channels per RLC entity or radio bearer RLC [TS 25.322]
>>Downlink transport channel type	MP		Enumerated(DCH,FACH,DSCH)	
>>DL Transport channel identity	CV-DL-DCH/DSCCH		Transport channel identity 10.3.5.18	
>>Logical channel identity	OP		Integer(1..15)	16 is reserved

Condition	Explanation
UL-RLC info	If "CHOICE Uplink RLC mode" in IE "RLC info" is present this IE is MP. Otherwise the IE is not needed.
DL-RLC info	If "CHOICE Downlink RLC mode" in IE "RLC info" is present this IE is MP. Otherwise the IE is not needed.
UL-RLCLogicalChannels	If "Number of uplink RLC logical channels" in IE "RB mapping info" is 2, then this is present. Otherwise this IE is not needed.
UL-DCH/USCH	If IE "Uplink transport channel type" is equal to "DCH" or "USCH" (TDD only) this IE is MP. Otherwise the IE is not needed.
DL-DCH/DSCH	If IE "Downlink transport channel type" is equal to "DCH" or "DSCH" this IE is MP. Otherwise the IE is not needed.

10.3.4.22 RB with PDCP information

Information Element/Group name	Need	Multi	Type and reference	Semantics description
RB identity	MP		RB identity 10.3.4.16	
PDCP SN info	MP		PDCP SN info 10.3.4.3	PDCP sequence number info from the sender of the message for lossless SRNS relocation.

10.3.4.23 RLC info

Information Element/Group name	Need	Multi	Type and reference	Semantics description
CHOICE Uplink RLC mode	OP			Indicates if Acknowledged, Unacknowledged or Transparent mode RLC shall be used. One spare value needed, criticality: reject.
>AM RLC				
>>Transmission RLC discard	MP		Transmission RLC discard 10.3.4.25	
>>Transmission window size	MP		Integer(1,8,16,32,64,128,256,512,768,1024,1536,2047,2560,3072,3584,4095)	Maximum number of RLC PUs sent without getting them acknowledged. This parameter is needed if acknowledged mode is used. UE shall also assume that the UTRAN receiver window is equal to this value.
>>Timer_RST	MP		Integer(50, 100, 150, 200, 250, 300, 350, 400, 450, 500, 550, 600, 700, 800, 900, 1000)	It is used to detect the loss of RESET ACK PDU. 16 spare values needed, criticality: reject
>>Max_RST	MP		Integer(1, 4, 6, 8, 12, 16, 24, 32)	The maximum number of retransmission of RESET PDU. 8 spare values needed, criticality: reject
>> Polling info	OP		Polling info 10.3.4.4	
>UM RLC				
>> Transmission RLC discard	OP		Transmission RLC discard 10.3.4.25	
>TM RLC				
>>Transmission RLC discard	OP		Transmission RLC discard 10.3.4.25	
>>Segmentation indication	MP		Boolean	TRUE indicates that segmentation is performed.
CHOICE Downlink RLC mode	OP			Indicates if Acknowledged, Unacknowledged or Transparent mode RLC shall be used. One spare value needed, criticality: reject.
>AM RLC				
>>In-sequence delivery	MP		Boolean	TRUE indicates that RLC shall preserve the order of higher layer PDUs when these are delivered. FALSE indicates that receiving RLC entity could allow SDUs to be delivered to the higher layer in different order than submitted to RLC sublayer at the transmitting side.
>>Receiving window size	MP		Integer(1,8,16,32,64,128,256,512,768,1024,1536,2047,2560,3072,3584,4095)	Maximum number of RLC PUs allowed to be received. This parameter is needed if acknowledged mode is used. UE shall also assume that the

				UTRAN transmitter window is equal to this value. At least one spare value with criticality reject needed
>>Downlink RLC status Info	MP		Downlink RLC status info 10.3.4.1	
>UM RLC				(No data)
>TM RLC				(No data)
>>Segmentation indication	MP		Boolean	TRUE indicates that segmentation is performed.

NOTE This information element is included within IE "Predefined RB configuration"

10.3.4.24 Signalling RB information to setup

Information Element/Group name	Need	Multi	Type and reference	Semantics description
RB identity	MD		RB identity 10.3.4.16	Default value is the smallest value not yet used as default in the message (e.g., 0, then 1, and so on) specified in subclause 8.6.4.54
CHOICE RLC info type	MP			At least one spare choice needed, critically: reject
>RLC info			RLC info 10.3.4.23	
RB mapping info	MP		RB mapping info 10.3.4.21	

NOTE This information element is included within IE "Predefined RB configuration"

10.3.4.25 Transmission RLC Discard

Information Element/Group name	Need	Multi	Type and reference	Semantics description
CHOICE SDU Discard Mode	MP			Different modes for discharge the RLC buffer on the transmitter side; "Timer based with explicit signalling", "Timer based without explicit signalling", "Discard after Max_DAT retransmissions" or "No_discard". For unacknowledged mode and transparent mode, only Timer based without explicit signalling is applicable. If "No_discard" is used, reset procedure shall be done after Max_DAT retransmissions
>Timer based explicit				
>>Timer_MRW	MP		Integer(50,60, 70, 80, 90, 100, 120, 140, 160, 180, 200, 300, 400, 500, 700, 900)	It is used to trigger the retransmission of a STATUS PDU containing an MRW SUFI field. 16 spare values needed, criticality: reject
>>Timer_discard	MP		Integer(100, 250, 500, 750, 1000, 1250, 1500, 1750, 2000, 2500, 3000, 3500, 4000, 4500, 5000, 7500)	Elapsed time in milliseconds before a SDU is discarded.
>>MaxMRW	MP		Integer(1, 4, 6, 8, 12, 16, 24, 32)	It is the maximum value for the number of retransmissions of a MRW command 8 spare values needed, criticality: ffs
>Timer based no explicit				
>>Timer_discard	MP		Integer(10,20,30,40,50,60,70,80,90,100)	Elapsed time in milliseconds before a SDU is discarded.
>Max DAT retransmissions				
>> Max_DAT	MP		Integer(1, 2, 3, 4, 5, 6, 7, 8, 9, 10, 15, 20, 25, 30, 35, 40)	Number of retransmissions of a PU before a SDU is discarded.
>>Timer_MRW	MP		Integer(50, 60, 70, 80, 90, 100, 120, 140, 160, 180, 200, 300, 400, 500, 700, 900)	It is used to trigger the retransmission of a STATUS PDU containing an MRW SUFI field. 16 spare values needed, criticality: reject
>>MaxMRW	MP		Integer(1, 4, 6, 8, 12, 16, 24, 32)	It is the maximum value for the number of retransmissions of a MRW command 8 spare values needed, criticality: ffs
>No discard				

>> Max_DAT	MP		Integer(1, 2, 3, 4, 5, 6, 7, 8, 9, 10, 15, 20, 25, 30, 35, 40)	Number of retransmissions of a PU before the RLC entity is reset.
------------	----	--	--	---

CHOICE SDU Discard Mode	Condition under which the given SDU Discard Mode is chosen
Timer based explicit	If the modes for discharge of the RLC buffer on the transmitter side is "Timer based with explicit signalling"
Timer based no explicit	If the modes for discharge of the RLC buffer on the transmitter side is "Timer based without explicit signalling" For unacknowledged mode, only Timer based without explicit signalling is applicable.
Max DAT retransmissions	If the modes for discharge of the RLC buffer on the transmitter side is "Discard after Max_DAT retransmissions"
No discard	If the modes for discharge the of RLC buffer on the transmitter side is "Reset procedure shall be done after Max_DAT retransmissions"

10.3.5 Transport CH Information elements

10.3.5.1 Added or Reconfigured DL TrCH information

Information Element/Group name	Need	Multi	Type and reference	Semantics description
DL Transport channel identity	MP		Transport channel identity 10.3.5.18	
CHOICE DL parameters				
>Independent				
>>TFS	MP		Transport Format Set 10.3.5.23	
>SameAsUL				
>>UL TrCH identity	MP		Transport channel identity 10.3.5.18	Same TFS applies as specified for indicated UL TrCH
DCH quality target	OP		Quality target 10.3.5.10	
Transparent mode signalling info	OP		Transparent mode signalling info 10.3.5.17	This IE is not used in RB RELEASE message nor RB RECONFIGURATION message

10.3.5.2 Added or Reconfigured UL TrCH information

Information Element/Group name	Need	Multi	Type and reference	Semantics description
UL Transport channel identity	MP		Transport channel identity 10.3.5.18	
TFS	MP		Transport Format Set 10.3.5.23	

NOTE This information element is included within IE "Predefined RB configuration"

10.3.5.3 CPCH set ID

NOTE: Only for FDD.

This information element indicates that this transport channel may use any of the Physical CPCH channels defined in the CPCH set info which contains the same CPCH set ID. The CPCH set ID associates the transport channel with a set of PCPCH channels defined in a CPCH set info IE and a set of CPCH persistency values. The CPCH set info IE(s) and the CPCH persistency values IE(s) each include the CPCH set ID and are part of the SYSTEM INFORMATION message

Information Element/Group name	Need	Multi	Type and reference	Semantics description
CPCH set ID	MP		Integer(1...maxCPCHsets)	Identifier for CPCH set info and CPCH persistency value messages

10.3.5.4 Deleted DL TrCH information

Information Element/Group name	Need	Multi	Type and reference	Semantics description
DL Transport channel identity	MP		Transport channel identity 10.3.5.18	

10.3.5.5 Deleted UL TrCH information

Information Element/Group name	Need	Multi	Type and reference	Semantics description
UL Transport channel identity	MP		Transport channel identity 10.3.5.18	

10.3.5.6 DL Transport channel information common for all transport channels

Information Element/Group name	Need	Multi	Type and reference	Semantics description
SCCPCH TFCS	OP		Transport Format Combination Set 10.3.5.20	This IE should be absent within IE "Predefined RB configuration"
CHOICE mode	OP			
>FDD				
>>CHOICE DL parameters	MP			
>>>Independent				
>>>>DL DCH TFCS	OP		Transport Format Combination Set 10.3.5.20	
>>>>SameAsUL				(no data)
>TDD				
>>Individual DL CCTrCH information	OP	1 to >maxCCTrCH>		
>>>DL TFCS Identity	MP		Transport format combination set identity 10.3.5.21	Identifies a special CCTrCH for shared or dedicated channels.
>>>>CHOICE DL parameters	MP			
>>>>>Independent				
>>>>>>DL TFCS	MP		Transport format combination set 10.3.5.20	
>>>>>>SameAsUL				
>>>>>>>UL DCH TFCS Identity	MP		Transport format combination set identity 10.3.5.21	Same TFCS applies as specified for the indicated UL DCH TFCS identity except for information applicable for UL only

NOTE This information element is included within IE "Predefined TrCh configuration"

10.3.5.7 DRAC Static Information

NOTE: Only for FDD.

Contains static parameters used by the DRAC procedure. Meaning and use is described in subclause 14.6.

Information Element/Group name	Need	Multi	Type and reference	Semantics description
Transmission Time Validity	MP		Integer(1..256)	number of frames
Time duration before retry	MP		Integer(1..256)	number of frames
DRAC Class Identity	MP		Integer(1..8)	Indicates the class of DRAC parameters to use in SIB10 message

10.3.5.8 Power Offset Information

Information Element/Group name	Need	Multi	Type and reference	Semantics description
CHOICE Gain Factors	MP			
>Signalled Gain Factors				
>>CHOICE mode				
>>>FDD				
>>>>Gain Factor α_c	MP		Integer (0.. 15)	For UL DPCCH or control part of PRACH or PCPCH
>>>TDD				(no data)
>>Gain Factor α_d	MP		Integer (0..15)	For UL DPDCH or data part of PRACH or PCPCH in FDD and all uplink channels in TDD
>>Reference TFC ID	OP		Integer (0..3)	If this TFC is a reference TFC, indicates the reference ID.
>Computed Gain Factors				
>>Reference TFC ID	MP		Integer (0.. 3)	Indicates the reference TFC Id of the TFC to be used to calculate the gain factors for this TFC. In case of using computed gain factors, at least one signalled gain factor is necessary for reference.
CHOICE mode				
>FDD				
>>Power offset P _{p-m}	OP		Integer(-5..10)	In dB. Power offset between the last transmitted preamble and the control part of the message (added to the preamble power to receive the power of the message control part) Needed only for PRACH
>TDD				(no data)

CHOICE Gain Factors	Condition under which the way to signal the Gain Factors is chosen
Signalled Gain Factors	The values for gain factors α_c (only in FDD mode) and α_d are signalled directly for a TFC.
Computed Gain Factors	The gain factors α_c (only in FDD mode) and α_d are computed for a TFC, based on the signalled settings for the associated reference TFC.

10.3.5.9 Predefined TrCH configuration

This information element concerns a pre- defined configuration of transport channel parameters.

Information Element/Group name	Need	Multi	Type and Reference	Semantics description
UL Transport channel information common for all transport channels	MP		UL Transport channel information common for all transport channels 10.3.5.24	
Added or Reconfigured TrCH information				
Added or Reconfigured UL TrCH information	MP	1 to <maxTrCH preconf>		
>Added or Reconfigured UL TrCH information	MP		Added or Reconfigured UL TrCH information 10.3.5.2	
DL Transport channel information common for all transport channels	MP		DL Transport channel information common for all transport channels 10.3.5.6	
Downlink transport channels				
Added or Reconfigured DL TrCH information	MP	1 to <maxTrCH preconf>		
>Added or Reconfigured DL TrCH information	MP		Added or Reconfigured DL TrCH information 10.3.5.1	

10.3.5.10 Quality Target

Information Element/Group name	Need	Multi	Type and reference	Semantics description
BLER Quality value	MP		Real(0.00 ..1.00, by step of 0.02)	In dB= -Log10(Transport channel BLER)

10.3.5.11 Semi-static Transport Format Information

Information Element/Group name	Need	Multi	Type and reference	Semantics description
Transmission time interval	MP		Integer(10, 20, 40, 80, dynamic)	In ms. The value dynamic is only used in TDD mode 3 spare values are needed Criticality reject
Type of channel coding	MP		Enumerated(No coding, Convolutional, Turbo)	
Coding Rate	CV-Coding		Enumerated(1/2, 1/3)	
Rate matching attribute	MP		Integer(1..hi RM)	
CRC size	MP		Integer(0, 8, 12, 16, 24)	in bits

Condition	Explanation
Coding	This IE is only present if IE "Type of channel coding" is "Convolutional"

10.3.5.12 TFCI Field 2 Information

UTRAN has the choice of two methods for signalling the mapping between TFCI (field 2) values and the corresponding TFC:

Method #1 - TFCI range

The mapping is described in terms of a number of groups, each group corresponding to a given transport format combination (value of CTFC(field2)). The CTFC(field2) value specified in the first group applies for all values of TFCI(field 2) between 0 and the specified 'Max TFCI(field2) value'. The CTFC(field2) value specified in the second group applies for all values of TFCI(field 2) between the 'Max TFCI(field2) value' specified in the last group plus one and the specified 'Max TFCI(field2) value' in the second group. The process continues in the same way for the following groups with the TFCI(field 2) value used by the UE in constructing its mapping table starting at the largest value reached in the previous group plus one. A range of TFCI values on the transport channel level can be configured to correspond to a range of codes in PDSCH mapping table.

Method #2 - Explicit

The mapping between TFCI(field 2) value and CTFC(field2) is spelt out explicitly for each value of TFCI (field2).

Information Element/Group name	Need	Multi	IE type and reference	Semantics description
CHOICE Signalling method	MP			
> TFCI range				
>> TFCI(field 2) range	MP	1 to <maxPDSCH-TFCIgroups>		
>>>Max TFCI(field2) value	MP		Integer(1..1023)	This is the Maximum value in the range of TFCI(field2) values for which the specified CTFC(field2) applies
>>>TFCS Information for DSCH (TFCI range method)	MP		TFCS Information for DSCH (TFCI range method) 10.3.5.14	
> Explicit				
>>TFCS explicit configuration	MP		TFCS explicit configuration 10.3.5.13	

CHOICE Signalling method	Condition under which Split type is chosen
TFCI range	
Explicit	

10.3.5.13 TFCS Explicit Configuration

Information Element/Group name	Need	Multi	IE type and reference	Semantics description
CHOICE TFCS representation	MP			
>Complete reconfiguration				
>>TFCS complete reconfiguration information	MP		TFCS Reconfiguration/Addition information 10.3.5.15	
>Addition				
>> TFCS addition information	MP		TFCS Reconfiguration/Addition information 10.3.5.15	
>Removal				
>> TFCS removal information	MP		TFCS Removal	

Information Element/Group name	Need	Multi	IE type and reference	Semantics description
			Information 10.3.5.16	
>Replace				
>> TFCS removal information	MP		TFCS Removal Information 10.3.5.16	
>> TFCS addition information	MP		TFCS Reconfiguration/Addition information 10.3.5.15	

10.3.5.14 TFCS Information for DSCH (TFCI range method)

The CTFC size should be chosen based on the maximum CTFC size for the UE. Integer number calculated according to clause 14. The calculation of CTFC ignores any DCH transport channels which may be assigned.

Information Element/Group name	Need	Multi	IE type and reference	Semantics description
CHOICE CTFC Size	MP			At least one, criticality: reject, spare value needed for future extension
>2 bit CTFC				
>>2bit CTFC	MP		Integer(0..3)	
>4 bit CTFC				
>>4bit CTFC	MP		Integer(0..15)	
>6 bit CTFC				
>>6 bit CTFC	MP		Integer(0..63)	
>8 bit CTFC				
>>8 bit CTFC	MP		Integer(0..255)	
>12 bit CTFC				
>>12 bit CTFC	MP		Integer(0..4095)	
>16 bit CTFC				
>>16 bit CTFC	MP		Integer(0..65535)	
>24 bit CTFC				
>>24 bit CTFC	MP		Integer(0..16777215)	

10.3.5.15 TFCS Reconfiguration/Addition Information

When it is used in TFCI field 1, the calculation of CTFC ignores any DSCH transport channels which may be assigned. When it is used in TFCI field 2, the calculation of CTFC ignores any DCH transport channels.

The CTFC size should be chosen based on the maximum CTFC size for the UE. The first instance of the parameter "CTFC information" corresponds to Transport format combination 0, the second to transport format combination 1 and so on when it is used besides the case of TFCS Addition. Integer number of CTFC calculated according to clause 14.

In case of TFCS Addition, the integer number(s) is the CTFC that is added. The new additional TFC(s) is inserted into the first available position(s) in the TFCI. CTFC size should be same as the size used in Complete reconfiguration.

Information Element/Group name	Need	Multi	IE type and reference	Semantics description
CHOICE CTFC Size	MP			At least one, criticality: reject, spare value needed for future extension
>2 bit CTFC				
>>CTFC information	MP	1 to <maxTFC>		
>>>2bit CTFC	MP		Integer(0..3)	
>>>Power offset Information	OP		Power Offset Information 10.3.5.8	Needed only for uplink physical channels.
>4 bit CTFC				
>>CTFC information	MP	1 to <maxTFC>		
>>>4bit CTFC	MP		Integer(0..15)	
>>>Power offset Information	OP		Power Offset Information 10.3.5.8	Needed only for uplink physical channels.
>6 bit CTFC				
>>CTFC information	MP	1 to <maxTFC>		
>>>6 bit CTFC	MP		Integer(0..63)	
>>>Power offset Information	OP		Power Offset Information 10.3.5.8	Needed only for uplink physical channels.
>8 bit CTFC				
>>CTFC information	MP	1 to <MaxTFC>		
>>>8 bit CTFC	MP		Integer(0..255)	
>>>Power offset Information	OP		Power Offset Information 10.3.5.8	Needed only for uplink physical channels.
>12 bit CTFC				
>>CTFC information	MP	1 to <maxTFC>		
>>>12 bit CTFC	MP		Integer(0..4095)	
>>>Power offset Information	OP		Power Offset Information 10.3.5.8	Needed only for uplink physical channels.
>16 bit CTFC				
>>CTFC information	MP	1 to <maxTFC>		
>>>16 bit CTFC	MP		Integer(0..65535)	
>>>Power offset Information	OP		Power Offset Information 10.3.5.8	Needed only for uplink physical channels.
>24 bit CTFC				
>>CTFC information	MP	1 to <MaxTFC>		
>>>24 bit CTFC	MP		Integer(0..16777215)	
>>>Power offset Information	OP		Power Offset Information 10.3.5.8	Needed only for uplink physical channels.

10.3.5.16 TFCS Removal Information

The integer number(s) is a reference to the transport format combinations to be removed.

Information Element/Group name	Need	Multi	IE type and reference	Semantics description
Removal TFCI information	MP	1 to <maxTFC>		
>TFCI	MP		Integer(0..1023)	

Range Bound	Explanation
MaxDelTFCCcount	Maximum number of Transport Format Combinations to be removed.

10.3.5.17 Transparent mode signalling info

This information element points out a transport channel that is used for transparent mode signalling, and which type of message that is sent on the DCCH mapped on that channel.

There are two modes of this transparent mode signaling. Mode 1 controls all transport channels for one UE. Mode 2 only control a subset of the transport channels for one UE.

Information Element	Need	Multi	Type and reference	Semantics description
Type of message	MP		Enumerated (TRANSPORT FORMAT COMBINATION CONTROL)	Indicates which type of message sent on the transparent mode signalling DCCH At least 1 spare value needed Criticality: criticality reject is needed
CHOICE Transparent signalling mode	MP			
>Mode 1				(no data)
>Mode 2				
>>Controlled transport channels list	MP	1 to <maxTrCH>		The transport channels that are effected by the rate control commands sent on this transparent mode DCCH
>>>UL Controlled transport channels	MP		Transport channel identity, 10.3.5.18	

10.3.5.18 Transport channel identity

This information element is used to distinguish transport channels. Transport channels of different type (RACH, CPCH, USCH, FACH/PCH, DSCH or DCH) have separate series of identities. This also holds for uplink and downlink transport channel identities (i.e. for DCH). Depending on in which context a transport channel identity n that is sent, it will have different meaning

Information Element/Group name	Need	Multi	Type and reference	Semantics description
Transport channel identity	MP		Integer(1..32)	

10.3.5.19 Transport Format Combination (TFC)

Information Element/Group name	Need	Multi	Type and reference	Semantics description
Transport format combination	MP		Integer (0..1023)	

10.3.5.20 Transport Format Combination Set

Indicates the allowed combinations of already defined Transport formats and the mapping between these allowed TFCs and the corresponding TFCI values.

For TDD, different coded composite transport channels have independent transport format combination sets and thus independent TFCI values.

For FDD, Where the UE is assigned access to one or more DSCH transport channels, a TFCI(field2) is used to signal the transport format combination for the DSCH. The following two cases exist:

- Case 1:
Using one TFCI-word on the physical layer. A logical split determines the available number of transport format combinations for DCH and DSCH.
- Case 2:
Using split TFCI on the physical layer. Two TFCI-words, each having a static length of five bits, are used.

Information Element/Group name	Need	Multi	IE type and reference	Semantics description
CHOICE TFCI signalling	MP			'Normal' : meaning no split in the TFCI field (either 'Logical' or 'Hard') 'Split' : meaning there is a split in the TFCI field (either 'Logical' or 'Hard'). This value is only valid for FDD downlink when using DSCH.
> Normal				
>> TFCI Field 1 Information	MP		TFCS explicit Configuration 10.3.5.13	
> Split				
>> Split type	OP		Enumerated ('Hard', 'Logical')	'Hard' : meaning that TFCI (field 1) and TFCI (field 2) are each 5 bits long and each field is block coded separately. 'Logical' : meaning that on the physical layer TFCI (field 1) and TFCI (field 2) are concatenated, field 1 taking the most significant bits and field 2 taking the least significant bits). The whole is then encoded with a single block code.
>> Length of TFCI(field2)	OP		Integer (1..10)	This IE indicates the length measured in number of bits of TFCI(field2)
>> TFCI Field 1 Information	OP		TFCS explicit Configuration 10.3.5.13	
>> TFCI Field 2 Information	OP		TFCI field 2 information 10.3.5.12	

CHOICE TFCI signalling	Condition under which TFCI signalling type is chosen
Normal	It is chosen when no split in the TFCI field.
Split	It is chosen when split in the TFCI field. This value is only valid for FDD downlink when using DSCH.

10.3.5.21 Transport Format Combination Set Identity

NOTE: Only for TDD.

Information Element/Group name	Need	Multi	Type and reference	Semantics description
TFCS ID	MD		Integer (1...8)	Indicates the identity of every TFCS within a UE. Default value is 1.
Shared Channel Indicator	MP		Boolean	TRUE indicates the use of shared channels. Default is false.

10.3.5.22 Transport Format Combination Subset

Indicates which Transport format combinations in the already defined Transport format combination set are allowed.

Information Element/Group name	Need	Multi	Type and reference	Semantics description
CHOICE Subset representation	MP			
>Minimum allowed Transport format combination index	MP		Transport format combination 10.3.5.19	The integer number is a reference to the Transport format combination, which arrived at that position in the Transport Format Combination Set.
>Allowed transport format combination list	MP	1 to <maxTFC>		
>>Allowed transport format combination	MP		Transport format combination 10.3.5.19	The integer number is a reference to the Transport format combination, which arrived at that position in the Transport Format Combination Set.
>Non-allowed transport format combination list	MP	1 to <maxTFC>		
>>Non-allowed transport format combination	MP		Transport format combination 10.3.5.19	The integer number is a reference to the Transport format combination, which arrived at that position in the Transport Format Combination Set.
>Restricted TrCH information	MP	1 to <maxTrCH >		
>>Restricted UL TrCH identity	MP		Transport channel identity 10.3.5.18	The integer number(s) is a reference to the transport channel that is restricted.
>>Allowed TFIs	OP	1 to <maxTF>		
>>>Allowed TFI	MP		Integer(0..31)	The integer number is a reference to the transport format that is allowed. If no elements are given, all transport formats or the TrCH with non-zero rate are restricted.

10.3.5.23 Transport Format Set

Information Element/Group name	Need	Multi	Type and reference	Semantics description
CHOICE Transport channel type	MP			
>Dedicated transport channels				The transport channel that is configured with this TFS is of type DCH
>>Dynamic Transport Format Information	MP	1 to <maxTF>		The first instance of the parameter Dynamic transport format information correspond to Transport format 0 for this transport channel, the second to transport format 1 and so on.
>>>Transmission Time Interval	CV-dynamicTTI		Integer(10,20,40,80)	ms 4 spare values are needed Criticality reject
>>>Number of Transport blocks	MP		Integer(0..512)	Note
>>>RLC Size	MP		Integer(0..4992)	Unit is bits
>>Semi-static Transport Format Information	MP		Semi-static Transport Format Information 10.3.5.11	
>Common transport channels				The transport channel that is configured with this TFS is of a type not equal to DCH
>>Dynamic Transport Format Information	MP	1 to <maxTF>		The first instance of the parameter Dynamic transport format information correspond to Transport format 0 for this transport channel, the second to transport format 1 and so on.
>>>Number of Transport blocks	MP		Integer(0..512)	Note
>>>RLC Size	MP		Integer(0..4992)	Unit is bits
>>>CHOICE mode	MP			
>>>>FDD				(no data)
>>>>TDD				
>>>> Transmission Time Interval	CV-dynamicTTI		Integer(10,20,40,80)	ms 4 spare values needed. Criticality reject
>>Semi-static Transport Format Information	MP		Semi-static Transport Format Information 10.3.5.11	

Condition	Explanation
dynamicTTI	This IE is included if dynamic TTI usage is indicated in IE Transmission Time Interval in Semi-static Transport Format Information. Otherwise it is not needed.

NOTE: The parameter "rate matching attribute" is in line with the RAN WG1 specifications. However, it is not currently in line with the description in 25.302.

NOTE: For dedicated channels, 'RLC size' reflects RLC PDU size. In FDD for common channels 'RLC size' reflects actual TB size. In TDD for common channels since MAC headers are not octet aligned, to calculate TB size the MAC header bit offset is added to the specified size (similar to the dedicated case). Therefore for TDD DCH TrCHs the 4 bit C/T is added if MAC multiplexing is applied, for FACH the 3 bit TCTF offset is added and for RACH the 2 bit TCTF offset is added.

NOTE: If the number of transport blocks $\neq 0$, and Optional IE "CHOICE RLC mode" or "CHOICE Transport block size" is absent, it implies that no RLC PDU data exists but only parity bits exist. If the number of transport blocks = 0, it implies that neither RLC PDU data nor parity bits exist. In order to ensure the possibility of CRC based Blind Transport Format Detection, UTRAN should configure a transport format with number of transport block $\neq 0$, with a zero-size transport block.

10.3.5.24 UL Transport channel information common for all transport channels

Information Element/Group name	Need	Multi	Type and reference	Semantics description
TFC subset	MD		Transport Format Combination Subset 10.3.5.22	Default value is the complete existing set of transport format combinations
PRACH TFCS	OP		Transport format combination set 10.3.5.20	This IE should be absent within IE "Predefined RB configuration"
CHOICE mode	OP			
>FDD				
>>UL DCH TFCS	MP		Transport format combination set 10.3.5.20	
>TDD				
>>Individual UL CCTrCH information	OP	1 to <maxCCTrCH>		
>>>UL TFCS Identity	MP		Transport format combination set identity 10.3.5.21	Identifies a special CCTrCH for shared or dedicated channels.
>>>UL TFCS	MP		Transport format combination set 10.3.5.20	

NOTE This information element is included within IE "Predefined TrCh configuration"

10.3.6 Physical CH Information elements

10.3.6.1 AC-to-ASC mapping

Information Element/Group name	Need	Multi	Type and reference	Semantics description
AC-to-ASC mapping table	MP	maxASCmap		
> AC-to-ASC mapping	MP		Integer(0..7)	Mapping of Access Classes to Access Service Classes (cf. Sec. 8.5.15.)

10.3.6.2 AICH Info

NOTE: Only for FDD.

Information Element/Group name	Need	Multi	Type and reference	Semantics description
Secondary scrambling code	MD		Secondary scrambling code 10.3.6.73	Default is the same scrambling code as for the Primary CPICH
Channelization code	MP		Integer(0..255)	SF is fixed and equal to 256
STTD indicator	MP		STTD Indicator 10.3.6.77	
AICH transmission timing	MP		Enumerated (0, 1)	See parameter AICH_Transmission_Timing in TS 25.211

10.3.6.3 AICH Power offset

NOTE: Only for FDD.

This is the power per transmitted Acquisition Indicator minus power of the Primary CPICH.

Information Element/Group name	Need	Multi	Type and reference	Semantics description
AICH Power offset	MP		Integer(-22..+5)	Offset in dB

10.3.6.4 Allocation period info

NOTE: Only for TDD.

Parameters used by UE to determine period of shared channel allocation.

Information Element/Group name	Need	Multi	Type and reference	Semantics description
Allocation Activation Time	MP		Integer (1..256)	Frame number start of the allocation period.
Allocation Duration	MP		Integer (1..256)	Total number of frames for the allocation period.

10.3.6.5 ASC setting

Information Element/Group name	Need	Multi	Type and reference	Semantics description
Available signature Start Index	MP		Integer(0..15)	
Available signature End Index	MP		Integer(0..15)	
Available sub-channel Start Index	MP		Integer(0..11)	
Available sub-channel End Index	MP		Integer(0..11)	

10.3.6.6 Block STTD indicator

NOTE: Only for TDD

Information Element/Group name	Need	Multi	Type and reference	Semantics description
Block STTD indicator	MP		Boolean	TRUE indicates that block STTD is used

10.3.6.7 CCTrCH power control info

Parameters used by UE to set the SIR target value for uplink open loop power control in TDD.

Information Element/Group name	Need	Multi	Type and Reference	Semantics description
TFCS Identity	OP		Transport Format Combination Set Identity 10.3.5.21	TFCS Identity of this CCTrCH. Default value is 1.
Uplink DPCH power control info	MP		Uplink DPCH power control info 10.3.6.89	

10.3.6.8 Cell parameters Id

Information Element/Group name	Need	Multi	Type and Reference	Semantics description
Cell parameter Id	MP		Integer(0..127)	

10.3.6.9 Common timeslot info

Information Element/Group name	Need	Multi	Type and reference	Semantics description
2nd interleaving mode	MD		Enumerated(Frame, Timeslot)	Frame timeslot related interleaving. Default value is "Frame"
TFCI coding	MD		Integer(4,8,16,32)	Describes the way the TFCI bits are coded in bits. Defaults is no TFCI bit: 4 means 1 TFCI bit is coded with 4 bits. 8 means 2 TFCI bits are coded with 8 bits. 16 means 3 – 5 TFCI bits are coded with 16 bits. 32 means 6 – 10 TFCI bits coded with 32 bits.
Puncturing limit	MP		Real(0.40..1.0 by step of 0.04)	
Repetition period	MD		Integer(1, 2,4,8,16,32,64)	Default is continuous allocation. Value 1 indicate continuous
Repetition length	MP		Integer(1..Repetition period –1)	Note that this is empty if repetition period is set to 1

10.3.6.10 Constant value

This constant value is used by the UE to calculate the initial output power on PRACH according to the Open loop power control procedure. In TDD constant values are used for open loop power control of PRACH, USCH and UL DPCH as defined in section 8.5.8.

Information Element/Group name	Need	Multi	Type and reference	Semantics description
Constant value	MP		Integer (-35..-10)	At least 6 spare values needed Criticality: reject is needed

10.3.6.11 CPCH persistence levels

NOTE: Only for FDD.

This IE is dynamic and is used by RNC for load balancing and congestion control. This is broadcast often in the system information message.

Information Element/Group name	Need	Multi	Type and reference	Semantics description
CPCH set ID	MP		Integer (1 .. <maxCPCHsets>)	Identifier for CPCH set info.
Dynamic persistence level	MP	1 to <maxTF-CPCH>	Dynamic persistence level 10.3.6.34	Persistence level for transport format.

10.3.6.12 CPCH set info

NOTE: Only for FDD.

This IE may be broadcast in the System Information message or assigned by SRNC. It is pseudo-static in a cell.

Information Element/Group name	Need	Multi	Type and reference	Semantics description
CPCH set ID	MP		CPCH set ID 10.3.5.3	Indicates the ID number for a particular CPCH set allocated to a cell.
TFS	MP		Transport Format Set 10.3.5.23	Transport Format Set Information allocated to this CPCH set.
TFCS	MP		Transport Format Combination Set 10.3.5.20	Transport Format Set Information allocated to this CPCH set
AP preamble scrambling code	MP		Integer (0..79)	Preamble scrambling code for AP in UL
AP-AICH scrambling code	MP		Secondary Scrambling Code 10.3.6.73	Default is the same scrambling code as for the primary CPICH.
AP-AICH channelization code	MP		Integer(0..255)	Channelization code for AP-AICH in DL
CD preamble scrambling code	MP		Integer (0..79)	Preamble scrambling code for CD in UL
CD/CA-ICH scrambling code	MD		Secondary Scrambling Code 10.3.6.73	Default is the same scrambling code as for the primary CPICH.
CD/CA-ICH channelization code	MP		Integer (0..255)	Channelization code for CD/CA-ICH in DL
Available CD access slot subchannel	CV-CDSigPresent	1 to <maxPCPCH-CDsubCh>		Lists the set of subchannels to be used for CD access preambles. Note: if not present, all subchannels are to be used without access delays.
>CD access slot subchannel	MP		Integer (0..11)	
Available CD signatures	OP	1 to <maxPCPCH-CDsig>		Signatures for CD preamble in UL. Note: if not present, all signatures are available for use.
>CD signatures	MP		Integer (0..15)	
DeltaPp-m	MP		Integer (-10..10)	In dB. Power offset between the transmitted CD preamble and UL DPCCH of the power control preamble or message part (added to the preamble power to calculate the power of the UL DPCCH)
UL DPCCH Slot Format	MP		Enumerated (0,1,2)	Slot format for UL DPCCH in power control preamble and in message part
N_start_message	MP		Integer (1..8)	Number of Frames for start of message indication
N_EOT	MP		Integer(0..7)	Actual number of appended EOT indicators is T_EOT = N_TTI * ceil(N_EOT/N_TTI), where N_TTI is the number of frames per TTI and "ceil" refers to rounding up to

				nearest integer.
Channel Assignment Active	OP		Boolean	When present, indicates that Node B send a CA message and VCAM mapping rule (14.11) shall be used.
CPCH status indication mode	MP		Enumerated (PCPCH availability, PCPCH availability and minimum available Spreading Factor)	Defines the status information type broadcast on the CPCH Status Indication Channel (CSICH)
PCPCH Channel Info.	MP	1 to <maxPCP CHs>		
> UL scrambling code	MP		Integer (0..79)	For PCPCH message part
> DL channelization code	MP		Integer (0..511)	For DL DPCCH for PCPCH message part
> DL scrambling code	MD		Secondary Scrambling Code 10.3.6.73	Default is the same scrambling code as for the primary CPICH.
> PCP length	MP		Enumerated (0, 8)	Indicates length of power control preamble, 0slots (no preamble used) or 8 slots
> UCSM Info	CV-NCAA			
>>Minimum Spreading Factor	MP		Integer (4,8,16,32,64,128,256)	The UE may use this PCPCH at any Spreading Factor equal to or greater than the indicated minimum Spreading Factor. The Spreading Factor for initial access is the minimum Spreading Factor.
>> NF_max	MP		Integer (1..64)	Maximum number of frames for PCPCH message part
>> Channel request parameters for UCSM	MP	1 to <maxSig>		Required in UE channel selection mode.
>>>Available AP signature	MP	1 to <maxPCP CH-APsig>		AP preamble signature codes for selection of this PCPCH channel.
>>>> AP signature	MP		Integer (0..15)	
>>>>Available AP access slot subchannel	OP	1 to <maxPCP CH-APsubCh>		Lists the set of subchannels to be used for AP access preambles in combination with the above AP signature(s). Note: if not present, all subchannels are to be used without access delays.
>>>> AP access slot subchannel	MP		Integer (0..11)	
VCAM info	CV-CAA			
> Available Minimum Spreading Factor	MP	1 to <maxPCP CH-SF>		
>> Minimum Spreading Factor	MP		Enumerated (4,8,16,32,64,128,256)	
>>NF_max	MP		Integer (1..64)	Maximum number of frames for PCPCH message part
>> Maximum available number of PCPCH	MP		Integer (1..64)	Maximum available number of PCPCH for the indicated

>> Available AP signatures	MP	1 to <maxPCP CH-APsig>		Spreading Factor. Signatures for AP preamble in UL.
>>> AP signature			Integer (0..15)	
>> Available AP sub-channel	OP	1 to <maxPCP CH-APsubCh>		AP sub-channels for the given AP signature in UL. Note: if not present, all subchannels are to be used without access delays.
>>> AP sub-channel	MP		Integer (0..11)	

Condition	Explanation
CDSigPresent	This IE may be included if IE "Available CD signatures" is present.
NCAA	This IE is included if IE "Channel Assignment Active" is not present
CAA	This IE is included if IE "Channel Assignment Active" is present.

10.3.6.13 CPCH Status Indication mode

CPCH Status Indication mode can take 2 values: PCPCH Availability (PA) mode and PCPCH Availability with Minimum Available Spreading Factor (PAMASF) mode. PAMASF mode is used when Channel Assignment is active. PA mode is used when Channel Assignment is not active (UE Channel Selection is active). These two separate modes are described independently in the subclause that follows. TS25.211 defines the Status Indicators (SIs) of the CSICH channel which convey the CPCH status information described here. A CSICH may contain from 3 upto a maximum of 60 Status Indicators.

10.3.6.13.1 PCPCH Availability (PA) mode

In PA mode, CPCH Status Indication conveys the PCPCH Channel Availability value which is a 1 to 16 bit value which indicates the availability of each of the 1 to 16 defined PCPCHs in the CPCH set. PCPCHs are numbered from PCPCH0 through PCPCH15. There is one bit of the PCPCH Channel Availability (PCA) value for each defined PCPCH channel. If there are 2 PCPCHs defined in the CPCH set, then there are 2 bits in the PCA value. And likewise for other numbers of defined PCPCH channels up to 16 maximum CPCH channels per set when UE Channel Selection is active.

The number of SIs (Status Indicators) per frame is a function of the number of defined PCPCH channels.

Number of defined PCPCHs(=K)	Number of SIs per frame(=N)
1, 2, 3	3
4,5	5
6,7,8,9,10,11,12,13,14,15	15
16	30

The value of the SI shall indicate the PCA value for one of the defined PCPCHs, where PCA(n)=1 indicates that the PCPCH is available, and PCA(n)=0 indicates that the PCPCHn is not available. SI(0) shall indicate PCA(0) for PCPCH0, SI(1) shall indicate PCA(1) for PCPCH1, etc., for each defined PCPCH. When the number of SIs per frame exceeds the number of defined PCPCHs (K), the SIs which exceed K shall be set to repeat the PCA values for the defined PCPCHs. In general ,

$$SI(n) = PCA(n \text{ mod } (K)),$$

where PCA(i) is availability of PCPCHi,

and n ranges from 0 to N-1.

10.3.6.13.2 PCPCH Availability with Minimum Available Spreading Factor (PAMASF) mode

In PAMASF mode, CPCH Status Indication conveys two pieces of information. One is the Minimum Available Spreading Factor (MASF) value and the other is the PCPCH Channel Availability (PCA) value.

- MASF is a 3 bit number with bits MASF0 through MASF2 where MASF0 is the MSB of the MASF value and MASF2 is the LSB of the MASF value.

The following table defines MASF(0), MASF(1) and MASF(2) values to convey the MASF. All spreading factors greater than MASF are available

Minimum Available Spreading Factor (MASF)	MASF(0)	MASF(1)	MASF(2)
N/A (No available CPCH resources)	0	0	0
256	0	0	1
128	0	1	0
64	0	1	1
32	1	0	0
16	1	0	1
08	1	1	0
04	1	1	1

The number of SIs (Status Indicators) per frame, N is a function of the number of defined PCPCH channels, K.

Number of defined PCPCHs(K)	Number of SIs per frame(N)
1, 2,	5
3,4,5,6,7,8,9,10,11,12	15
13,14,15,16,17,18,19,20,21,22,23,24,25,26,27	30
28...57	60

PCA(n)=1 indicates that the PCPCHn is available, and PCA(n)=0 indicates that the PCPCHn is not available. PCA value for each PCPCH channel defined in a CPCH set shall be assigned to one SI (Status Indicator), and 3-bit MASF value shall be assigned to SIs as shown in Figure 61.

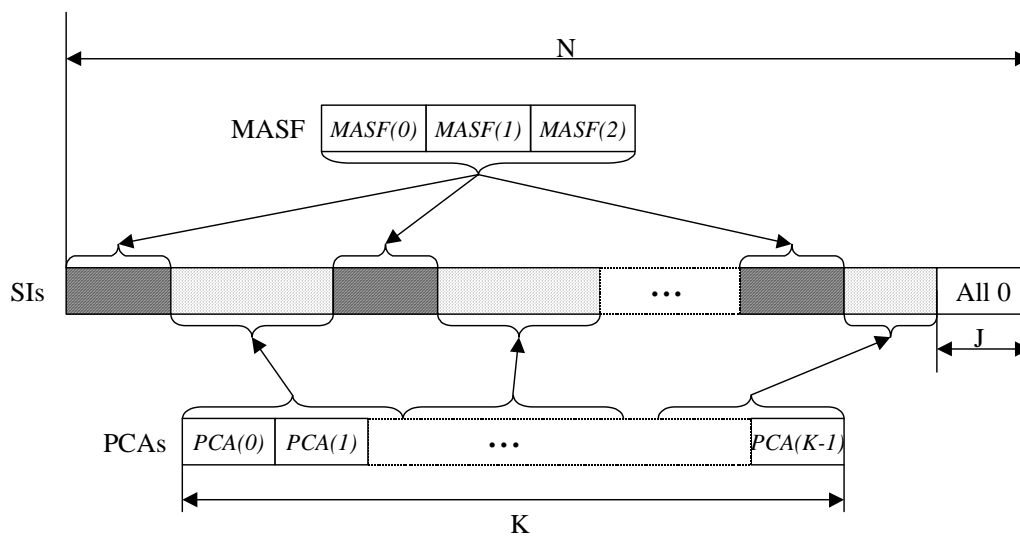

Figure 61: Mapping of MASF and PCAs to SIs in CSICH

The number of repetition that 3-bit MASF values shall be repeated is

$$T = \lfloor (N - K) / 3 \rfloor$$

where $\lfloor x \rfloor$ is largest integer less than or equal to x . Each MASF value i , $MA SF(n)$, shall be mapped to SI as follows.

$$SI_{l(t+4)+i} = MAS F(i), \quad 0 \leq i \leq 2 \quad l = 0, 1, \dots, s-1$$

$$SI_{s+l(t+3)+i} = MAS F(i), \quad 0 \leq i \leq 2 \quad l = s, s+1, \dots, T-1$$

where

$$t = \lfloor K / T \rfloor$$

and

$$s = K - t \cdot T$$

Each PCA value bit, $PCA(n)$, shall be mapped to SI as follows.

$$SI_{l(t+4)+j+3} = PCA(l+l \cdot t + j), \quad 0 \leq j \leq 2 \quad l = 0, 1, \dots, s-1$$

$$SI_{s+l(t+3)+j+3} = PCA(s+l \cdot t + j), \quad 0 \leq j \leq 2 \quad l = s, s+1, \dots, T-1$$

The remaining

$$J = N - (3T + K)$$

SIs shall be set to 0.

10.3.6.14 CSICH Power offset

NOTE: Only for FDD.

This is the power per transmitted CSICH Indicator minus power of the Primary CPICH.

Information Element/Group name	Need	Multi	Type and reference	Semantics description
CSICH Power offset	MP		Integer(-10..+5)	Offset in dB, granularity of 1 dB

10.3.6.15 Default DPCH Offset Value

Indicates the default offset value within interleaving size at a resolution of 512chip (1/5 slot) in FDD and a resolution of one frame in TDD to offset CFN in the UE. This is used to distribute discontinuous transmission periods in time and also to distribute NodeB-RNC transmission traffics in time. Even though the CFN is offset by DOFF, the start timing of the interleaving will be the timing that "CFN mod (interleaving size)"=0 (e.g. interleaving size: 2,4,8) in both UE and SRNC.

Information Element/Group name	Need	Multi	Type and reference	Semantics description
CHOICE mode				
>FDD				
>>Default DPCH Offset Value (DOFF)	MP		Integer (0..306688 by step of 512)	Number of chips=. 0 to 599 time 512 chips, see TS 25.402. At least 424 spare values needed Criticality: reject is needed
>TDD				
>>Default DPCH Offset Value (DOFF)	MP		Integer(0..7)	Number of frames; See TS 25.402

10.3.6.16 Downlink channelization codes

NOTE: Only for TDD

Information Element/Group name	Need	Multi	Type and reference	Semantics description
CHOICE codes representation	MP			
>Consecutive codes				
>>First channelization code	MP		Enumerated ((16/1)...(16/16))	The codes from First channelization code to Last channelization code shall be used in that order by the physical layer in this timeslot. If a TFCI exists in this timeslot, it is mapped in the First channelization code.
>>Last channelization code	MP		Enumerated ((16/1)...(16/16))	If this is the same as First channelization code, only one code is used by the physical layer.
>Bitmap				
>>Channelization codes bitmap	MP		Bitmap(16)	The first bit in this bitmap corresponds to channelization code (16/1) the second to (16/2) and so on. A 1 in the bitmap means that the code is used in this timeslot, a 0 that the code is not used. The codes shall be used in the order from (16/1) to (16/16) by the physical layer.

10.3.6.17 Downlink DPCH info common for all RL

Information Element/Group name	Need	Multi	Type and reference	Semantics description
Timing Indication	MP		Enumerated(Initialise, Maintain)	
CFN-targetSFN frame offset	OP		Integer(0..255)	In frame
CHOICE mode				
>FDD				
>>Downlink DPCH power control information	OP		Downlink DPCH power control information 10.3.6.22	
>>Downlink rate matching restriction information	OP		Downlink rate matching restriction information 10.3.6.30	If this IE is set to "absent", no Transport CH is restricted in TFI.
>>Spreading factor	MP		Integer(4, 8, 16, 32, 64, 128, 256, 512)	
>>Fixed or Flexible Position	MP		Enumerated (Fixed, Flexible)	
>>TFCI existence	MP		Boolean	TRUE indicates that TFCI exists
>>CHOICE SF	MP			
>>> SF = 256				
>>>> Number of bits for Pilot bits	MP		Integer (2,4,8)	In bits
>>> SF = 128				
>>>>Number of bits for Pilot bits	MP		Integer(4,8)	In bits
>>> Otherwise				(no data)
>TDD				
>>Common timeslot info	MD		Common Timeslot Info 10.3.6.9	Default is the current Common timeslot info

CHOICE SF	Condition under which the given SF is chosen
SF=128	"Spreading factor" is set to 128
SF=256	"Spreading factor" is set to 256
Otherwise	"Spreading factor" is set to a value distinct from 128 and 256

10.3.6.18 Downlink DPCH info common for all RL Post

NOTE: Only for FDD

Information Element/Group name	Need	Multi	Type and reference	Semantics description
Timing Indication	MP		Enumerated(Initialise, Maintain)	
CFN-targetSFN frame offset	OP		Integer(0..255)	In frame
Downlink DPCH power control information	OP		Downlink DPCH power control information 10.3.6.22	

10.3.6.19 Downlink DPCH info common for all RL Pre

Information Element/Group name	Need	Multi	Type and reference	Semantics description
CHOICE mode	MP			
>FDD				
>>Timing Indication	MP		Enumerated(Initialise, Maintain)	
>>CFN-targetSFN frame offset	OP		Integer(0..255)	In frame
>>Spreading factor	MP		Integer(4, 8, 16, 32, 64, 128, 256, 512)	Defined in CHOICE SF512-Andpilot with "number of its for pilot bits" in ASN.1
>>Fixed or Flexible Position	MP		Enumerated(Fixed, Flexible)	
>>TFCI existence	MP		Boolean	TRUE indicates that TFCI exists
>>CHOICE SF	MP			
>>> SF = 256				
>>>> Number of bits for Pilot bits	MP		Integer(2,4,8)	In bits
>>> SF = 128				
>>>>Number of bits for Pilot bits	MP		Integer(4,8)	In bits
>>> Otherwise				(no data)
>TDD				
>>Common timeslot info	MP		Common Timeslot Info 10.3.6.9	

CHOICE SF	Condition under which the given SF is chosen
SF=128	"Spreading factor" is set to 128
SF=256	"Spreading factor" is set to 256
Otherwise	"Spreading factor" is set to a value distinct from 128 and 256

10.3.6.20 Downlink DPCH info for each RL

Information Element/Group name	Need	Multi	Type and reference	Semantics description
CHOICE mode	MP			
>FDD				
>>Primary CPICH usage for channel estimation	MP		Primary CPICH usage for channel estimation 10.3.6.61	
>>DPCH frame offset	MP		Integer(0..381 44 by step of 256)	Offset (in number of chips) between the beginning of the P-CCPCH frame and the beginning of the DPCH frame This is called $\tau_{DPCH,n}$ in TS 25.211
>>Secondary CPICH info	OP		Secondary CPICH info 10.3.6.72	
>>DL channelization code	MP	1 to <maxDPC H-DLchan>		SF of the channelization code of the data part for each DPCH
>>>Secondary scrambling code	MD		Secondary scrambling code 10.3.6.73	Default is the same scrambling code as for the Primary CPICH
>>> CHOICE Spreading factor	MP		Integer(4, 8, 16, 32, 64, 128, 256, 512)	Defined in CHOICE SF512-AndCodenumbr with "code number" in ASN.1.
>>>Code number	MP		Integer(0..Spreading factor - 1)	
>>> Scrambling code change	CH SF/2		Enumerated (code change, no code change)	Indicates whether the alternative scrambling code is used for compressed mode method 'SF/2'.
>>TPC combination index	MP		TPC combination index 10.3.6.83	
>>SSDT Cell Identity	OP		SSDT Cell Identity 10.3.6.75	
>>Closed loop timing adjustment mode	CH TxDiversity Mode		Integer(1, 2)	It is present if current TX Diversity Mode in UE is "closed loop mode 1" or "closed loop mode 2". Value in slots
>TDD				
>>DL CCTrCh List	MP	1..<maxCC TrCh>		
>>>TFCS ID	MD		Integer(1..8)	Identity of this CCTrCh. Default value is 1
>>>Time info	MP		Time Info 10.3.6.81	
>>>Downlink DPCH timeslots and codes	MD		Downlink Timeslots and Codes 10.3.6.31	Default is to use the old timeslots and codes.
>>>UL CCTrCH TPC List	MD	1..<maxCC TrCh>		UL CCTrCH identities for TPC commands associated with this DL CCTrCH. Default is previous list or all defined UL CCTrCHs
>>>>UL TPC TFCS Identity	MP		Transport Format	

Information Element/Group name	Need	Multi	Type and reference	Semantics description
			Combination Set Identity 10.3.5.21	

Condition	Explanation
SF/2	The information element is mandatory if the UE has an active compressed mode pattern sequence, which is using compressed mode method "SF/2". Otherwise the IE is not needed.
TxDiversity Mode	This IE is present if current TX Diversity Mode in UE is "closed loop mode 1" or "closed loop mode 2". Otherwise the IE is not needed.

10.3.6.21 Downlink DPCH info for each RL Post

Information Element/Group name	Need	Multi	Type and reference	Semantics description
CHOICE mode	MP			
>FDD				
>>Primary CPICH usage for channel estimation	MP		Primary CPICH usage for channel estimation 10.3.6.61	
>>Secondary scrambling code	MD		Secondary scrambling code 10.3.6.73	Default is the same scrambling code as for the Primary CPICH
>>Code number	MP		Integer(0..max CodeNum)	
>>TPC combination index	MP		TPC combination index 10.3.6.83	
>TDD				
>>Downlink DPCH timeslots and codes	MP		Downlink Timeslots and Codes 10.3.6.31	

10.3.6.22 Downlink DPCH power control information

Information Element/Group name	Need	Multi	Type and reference	Semantics description
CHOICE mode	MP			
>FDD				
>>DPC Mode	MP		Enumerated (Single TPC, TPC triplet in soft)	"Single TPC" is DPC_Mode=0 and "TPC triplet in soft" is DPC_mode=1 in [TS 25.214]
> TDD				
>>TPC Step Size	OP		Integer (1, 2, 3)	In dB

10.3.6.23 Downlink information common for all radio links

Information Element/Group name	Need	Multi	Type and reference	Semantics description
Downlink DPCH info common for all RL	OP		Downlink DPCH info common for all RL 10.3.6.17	
CHOICE mode				
>FDD				
>>DPCH compressed mode info	MD		DPCH compressed mode info 10.3.6.32	Default value is the existing value of DPCH compressed mode information
>>TX Diversity Mode	MD		TX Diversity Mode 10.3.6.84	Default value is the existing value of TX Diversity mode
>>SSDT information	OP		SSDT information 10.3.6.76	
>TDD				(no data)
>>Default DPCH Offset Value	OP		Default DPCH Offset Value, 10.3.6.15	

10.3.6.24 Downlink information common for all radio links Post

NOTE: Only for FDD

Information Element/Group name	Need	Multi	Type and reference	Semantics description
Downlink DPCH info common for all RL	MP		Downlink DPCH info common for all RL Post 10.3.6.18	

10.3.6.25 Downlink information common for all radio links Pre

Information Element/Group name	Need	Multi	Type and reference	Semantics description
Downlink DPCH info common for all RL	MP		Downlink DPCH info common for all RL Pre 10.3.6.19	
Default DPCH Offset Value	OP		Default DPCH Offset Value, 10.3.6.15	

10.3.6.26 Downlink information for each radio link

Information Element/Group name	Need	Multi	Type and reference	Semantics description
Choice mode	MP			
>FDD				
>>Primary CPICH info	MP		Primary CPICH info 10.3.6.59	
>>PDSCH with SHO DCH Info	OP		PDSCH with SHO DCH Info 10.3.6.46	
>>PDSCH code mapping	OP		PDSCH code mapping 10.3.6.42	
>TDD				
>>Primary CCPCH info	OP		Primary CCPCH info 10.3.6.56	
Downlink DPCH info for each RL	OP		Downlink DPCH info for each RL 10.3.6.20	Note 1
Secondary CCPCH info	OP		Secondary CCPCH info 10.3.6.70	
References to system information blocks	OP	1 to <maxSIB-FACH>		Note 1
>Scheduling information	MP		Scheduling information 10.3.8.12	Note 1

NOTE 1: This IE shall not be set in case of CELL_UPDATE_CONFIRM message.

10.3.6.27 Downlink information for each radio link Post

Information Element/Group name	Need	Multi	Type and reference	Semantics description
Choice mode	MP			
>FDD				
>>Primary CPICH info	MP		Primary CPICH info 10.3.6.59	
>TDD				
>>Primary CCPCH info	MP		Primary CCPCH info post 10.3.6.49a	
Downlink DPCH info for each RL	MP		Downlink DPCH info for each RL Post 10.3.6.18	

10.3.6.28 Downlink Outer Loop Control

This information element indicates whether the UE is allowed or not to increase its downlink SIR target value above the current value.

Information Element/Group name	Need	Multi	Type and reference	Semantics description
DL Outer loop control	MP		Enumerated(Increase allowed, Increase not allowed)	

10.3.6.29 Downlink PDSCH information

NOTE: Only for FDD.

Information Element/Group name	Need	Multi	Type and reference	Semantics description
>>PDSCH with SHO DCH Info	OP		PDSCH with SHO DCH Info 10.3.6.46	
>>PDSCH code mapping	OP		PDSCH code mapping 10.3.6.42	

10.3.6.30 Downlink rate matching restriction information

This IE indicates which TrCH is restricted in TFI. DL rate matching should be done based on the TFCS which is the subset of the "DL TFCS with no restricted Transport channel".

Information Element/Group name	Need	Multi	Type and reference	Semantics description
Restricted TrCH information	OP	1 to <maxTrCH >		
>Restricted DL TrCH identity	MP		Transport channel identity 10.3.5.18	
>Allowed TFIs	MP	1 to <maxTF>		
>>Allowed TFI	MP		Integer(0..31)	

10.3.6.31 Downlink Timeslots and Codes

NOTE: Only for TDD

Information Element/Group name	Need	Multi	Type and reference	Semantics description
First Individual timeslot info	MP		Individual timeslot info 10.3.6.36	Individual timeslot info for the first timeslot used by the physical layer.
First timeslot channelization codes	MP		Downlink channelization codes 10.3.6.16	These codes shall be used by the physical layer in the timeslot given in First Individual timeslot info.
CHOICE more timeslots	MP			
>No more timeslots				(no data)
>Consecutive timeslots				
>>Number of additional timeslots	MP		Integer(1..maxTS-1)	The timeslots used by the physical layer shall be timeslots: N mod maxTS (N+1) mod maxTS ... (N+k) mod maxTS in that order, where N is the timeslot number in the First individual timeslot info and k the Number of additional timeslots. The additional timeslots shall use the same parameters (e.g. channelization codes, midamble shifts etc.) as the first timeslot.
>Timeslot list				
>>Additional timeslot list	MP	1 to <maxTS-1>		The first instance of this parameter corresponds to the timeslot that shall be used second by the physical layer, the second to the timeslot that shall be used third and so on.
>>>CHOICE parameters	MP			
>>>>Same as last				
>>>>Timeslot number	MP		Timeslot Number 10.3.6.81	The physical layer shall use the same parameters (e.g. channelization codes, midamble shifts etc.) for this timeslot as for the last one.
>>>>New parameters				
>>>>Individual timeslot info	MP		Individual timeslot info 10.3.6.36	
>>>>Channelization codes	MP		Downlink channelization codes 10.3.6.16	

10.3.6.32 DPCH compressed mode info

NOTE: Only for FDD.

This information element indicates the parameters of the downlink compressed mode to be used by the UE in order to perform inter-frequency measurements.

Information Element/Group name	Need	Multi	Type and reference	Semantics description
Transmission gap pattern sequence		1 to <maxTGPS>		
> TGPSI	MP		TGPSI	

Information Element/Group name	Need	Multi	Type and reference	Semantics description
			10.3.6.80	
>TGPS Status Flag	MP		Enumerated(active, inactive)	This flag indicates the current status of the Transmission Gap Pattern Sequence, whether it shall be activated or deactivated.
>Transmission gap pattern sequence configuration parameters	OP			
>> TGMP	MP		Enumerated(TDD measurement, FDD measurement, GSM measurement, Other)	Transmission Gap pattern sequence Measurement Purpose.
>> TGPRC	MP		Integer (1..63, Infinity)	The number of transmission gap patterns within the Transmission Gap Pattern Sequence.
>> TGCFN	MP		Integer (0..255)	Connection Frame Number of the first frame of the first pattern within the Transmission Gap Pattern Sequence.
>> TGSN	MP		Integer (0..14)	Transmission Gap Starting Slot Number The slot number of the first transmission gap slot within the TGCFN.

Information Element/Group name	Need	Multi	Type and reference	Semantics description
>>TGL1	MP		Integer(1..14)	The length of the first Transmission Gap within the transmission gap pattern expressed in number of slots
>> TGL2	MD		Integer (1..14)	The length of the second Transmission Gap within the transmission gap pattern. If omitted, then TGL2=TGL1.
>>TGD	MP		Integer(15..269, undefined)	Transmission gap distance indicates the number of slots between starting slots of two consecutive transmission gaps within a transmission gap pattern. If there is only one transmission gap in the transmission gap pattern, this parameter shall be set to zero.
>> TGPL1	MP		Integer (1..144)	The duration of transmission gap pattern 1.
>> TGPL2	MD		Integer (1..144)	The duration of transmission gap pattern 2. If omitted, then TGPL2=TGPL1.
>>RPP	MP		Enumerated (mode 0, mode 1).	Recovery Period Power control mode during the frame after the transmission gap within the compressed frame. Indicates whether normal PC mode or compressed PC mode is applied
>>ITP	MP		Enumerated (mode 0, mode 1).	Initial Transmit Power is the uplink power control method to be used to compute the initial transmit power after the compressed mode gap.
>>UL/DL mode	MP		Enumerated (UL only, DL only, UL/DL)	Defines whether only DL, only UL, or combined UL/DL compressed mode is used.
>> Downlink compressed mode method	CV DL		Enumerated (puncturing, SF/2, higher layer scheduling)	Method for generating downlink compressed mode gap
>> Uplink compressed mode method	CV UL		Enumerated (SF/2, higher layer scheduling)	Method for generating uplink compressed mode gap
>>Downlink frame type	MP		Enumerated (A, B)	
>>DeltaSIR1	MP		Real(0..3 by step of 0.1)	Delta in DL SIR target value to be set in the UE during the compressed frames corresponding to the first transmission gap in the transmission gap pattern (without including the effect of the bit-rate increase)
>>DeltaSIRafter1	MP		Real(0..3 by step of 0.1)	Delta in DL SIR target value to be set in the UE one frame after the compressed frames corresponding to the first transmission gap in the transmission gap pattern.
>>DeltaSIR2	OP		Real(0..3 by step of 0.1)	Delta in DL SIR target value to be set in the UE during the compressed frames

Information Element/Group name	Need	Multi	Type and reference	Semantics description
				corresponding to the second transmission gap in the transmission gap pattern (without including the effect of the bit-rate increase) When omitted, DeltaSIR2 = DeltaSIR1.
>>DeltaSIRafter2	OP		Real(0..3 by step of 0.1)	Delta in DL SIR target value to be set in the UE one frame after the compressed frames corresponding to the second transmission gap in the transmission gap pattern. When omitted, DeltaSIRafter2 = DeltaSIRafter1.

Condition	Explanation
UL	This information element is only sent when the value of the "UL/DL mode" IE is "UL only" or "UL/DL".
DL	This information element is only sent when the value of the "UL/DL mode" IE is "DL only" or "UL/DL".

10.3.6.33 DPCH Compressed Mode Status Info

Information Element/Group name	Need	Multi	Type and reference	Semantics description
Transmission gap pattern sequence		1 to <maxTGP S>		
> TGPSI	MP		TGPSI 10.3.6.80	Transmission Gap Pattern Sequence Identifier
> TGPS Status Flag	MP		Enumerated(active, inactive)	This flag indicates the current status of the Transmission Gap Pattern Sequence, whether it shall be active or inactive.

10.3.6.34 Dynamic persistence level

Information Element/Group name	Need	Multi	Type and reference	Semantics description
Dynamic persistence level	MP		Integer(1..8)	Level shall be mapped to a dynamic persistence value in the range 0 .. 1.

10.3.6.35 Frequency info

Information Element/Group name	Need	Multi	Type and reference	Semantics description
CHOICE mode	MP			
>FDD				
>>UARFCN uplink (Nu)	OP		Integer(0..16383)	[25.101] If IE not present, default duplex distance of 190 MHz shall be used.
>>UARFCN downlink (Nd)	MP		Integer(0 .. 16383)	[25.101]
>TDD				
>>UARFCN (Nt)	MP		Integer(0 .. 16383)	[25.102]

10.3.6.36 Individual timeslot info

Information Element/Group name	Need	Multi	Type and reference	Semantics description
Timeslot number	MP		Timeslot number 10.3.6.81	Timeslot within a frame
TFCI existence	MP		Boolean	TRUE indicates that the TFCI exists. It shall be coded in the first physical channel of this timeslot.
Midamble Shift and burst type	MP		Midamble shift and burst type 10.3.6.40	

10.3.6.37 Individual Timeslot interference

Parameters used by the UE for uplink open loop power control in TDD.

Information element	Need	Multi	Type and reference	Semantics description
Timeslot number	MP		Timeslot number 10.3.6.81	
UL Timeslot Interference	MP		ULInterference 10.3.6.85	

10.3.6.38 Maximum allowed UL TX power

This information element indicates the maximum allowed uplink transmit power.

Information Element	Need	Multi	Type and reference	Semantics description
Maximum allowed UL TX power	MP		Integer(-50..33)	In dBm At least 44 spare values are needed Criticality: reject is needed

10.3.6.39 Midamble configuration

NOTE: Only for TDD.

Information Element/Group name	Need	Multi	Type and reference	Semantics description
Midamble burst type 1	MD		Integer(4, 8,16)	Maximum number of midamble shifts for burst type 1. Default value is 8.
Midamble burst type 2	MD		Integer(3, 6)	Maximum number of midamble shifts for bursttype 2. Default value is 3.

Default value is all the subfields set to their default value.

10.3.6.40 Midamble shift and burst type

NOTE: Only for TDD.

This information element indicates burst type and midamble allocation. Three different midamble allocation schemes exist:

- Default midamble: the midamble shift is selected by layer 1 depending on the associated channelization code (DL and UL)
- Common midamble: the midamble shift is chosen by layer 1 depending on the number of channelization codes (possible in DL only)
- UE specific midamble: a UE specific midamble is explicitly assigned (DL and UL).

Information Element/Group name	Need	Multi	Type and reference	Semantics description
CHOICE Burst Type	MP			
>Type 1				
>>Midamble Allocation Mode	MP		Enumerated (Default midamble, Common midamble, UE specific midamble)	At least 1 spare value (criticality = reject) required.
>>Midamble Shift	CV UE		Integer(0..15)	
>Type 2				
>>Midamble Allocation Mode	MP		Enumerated (Default midamble, Common midamble, UE specific midamble)	At least 1 spare value (criticality = reject) required.
>>Midamble Shift	CV UE		Integer(0..5)	
>Type 3				
>>Midamble Allocation Mode	MP		Enumerated (Default midamble, UE specific midamble)	
>>Midamble Shift	CV UE		Integer (0..7)	NOTE: Burst Type 3 is only used in uplink.

Condition	Explanation
UE	This information element is only sent when the value of the "Midamble Allocation Mode" IE is "UE-specific midamble".

10.3.6.41 PDSCH Capacity Allocation info

NOTE: Only for TDD.

Information Element/Group name	Need	Multi	Type and reference	Semantics description
PDSCH allocation period info	MP		Allocation Period Info 10.3.6.4	
TFCS ID	MD		Integer(1..8)	Default is 1.
CHOICE Configuration	MP			
>Old configuration				
>>PDSCH Identity	MP		Integer(1..Hi PDSCHIdentities)	
>New configuration				
>>PDSCH Info	MP		PDSCH Info 10.3.6.43	
>>PDSCH Identity	OP		Integer(1..Hi PDSCHIdentities)	
>>PDSCH power control info	OP		PDSCH power control info 10.3.6.44	

10.3.6.42 PDSCH code mapping

NOTE: Only for FDD.

This IE indicates the association between each possible value of TFCI(field 2) and the corresponding PDSCH channelization code(s). There are three fundamentally different ways that the UTRAN must choose between in order to signal the mapping information, these are described below. The signalling capacity consumed by the different methods will vary depending on the way in which the UTRAN configures usage of the DSCH. A fourth option is also provided which allows the UTRAN to replace individual entries in the TFCI(field 2) to PDSCH code mapping table with new PDSCH code values.

There are four different signalling methods defined. The signalling method shall be selected by the UTRAN.

Method #1 - Using code range

The mapping is described in terms of a number of groups, each group associated with a given spreading factor. The UE maps TFCI(field2) values to PDSCH codes in the following way. The PDSCH code used for TFCI(field 2) = 0, is given by the SF and code number = 'PDSCH code start' of Group = 1. The PDSCH code used for TFCI(field 2) = 1, is given by the SF and code number = 'PDSCH code start' + 1. This continues, with unit increments in the value of TFCI(field 2) mapping to unit increments in code number up until the point that code number = 'PDSCH code stop'. The process continues in the same way for the next group with the TFCI(field 2) value used by the UE when constructing its mapping table starting at the largest value reached in the previous group plus one. In the event that 'PDSCH code start' = 'PDSCH code stop' (as may occur when mapping the PDSCH root code to a TFCI(field 2) value) then this is to be interpreted as defining the mapping between the channelization code and a single TFCI (i.e., TFCI(field 2) should not be incremented twice).

Note that each value of TFCI (field 2) is associated with a given 'code number' and when the 'multi-code info' parameter is greater than 1, then each value of TFCI (field 2) actually maps to a set of PDSCH codes. In this case contiguous codes are assigned, starting at the channelization code denoted by the 'code number' parameter and including all codes with code numbers up to and including 'code number' - 1 + the value given in the parameter 'multi-code info'.

Method #2 - Using TFCI range

The mapping is described in terms of a number of groups, each group corresponding to a given PDSCH channelization code. The PDSCH code specified in the first group applies for all values of TFCI(field 2) between 0 and the specified 'Max TFCI(field2)'. The PDSCH code specified in the second group applies for all values of TFCI(field 2) between the 'Max TFCI(field2) value' specified in the last group plus one and the specified 'Max TFCI(field2)' in the second group. The process continues in the same way for the following groups with the TFCI(field 2) value starting at the largest value reached in the previous group plus one.

Method #3 - Explicit

The mapping between TFCI(field 2) value and PDSCH channelization code is spelt out explicitly for each value of TFCI (field2)

Information Element/Group name	Need	Multi	Type and reference	Semantics description
DL Scrambling Code	MD		Secondary scrambling code 10.3.6.73	Scrambling code on which PDSCH is transmitted. Default is the same scrambling code as for the Primary CPICH
Choice signalling method	MP			
>code range				
>>PDSCH code mapping	MP	1 to < maxPDSC H- TFCI group s >		
>>>Spreading factor	MP		Integer(4, 8, 16, 32, 64, 128, 256)	At least 1 spare value needed Criticality: reject is needed
>>>multi-code info	MP		Integer(1..16)	This parameter indicates the number of PDSCH transmitted to the UE. The PDSCH codes all have the same SF as denoted by the 'Spreading factor' parameter. Contiguous codes are assigned, starting at the channelization code

Information Element/Group name	Need	Multi	Type and reference	Semantics description
				denoted by the spreading factor and code number parameter and including all codes, with code numbers up to and including 'code number' - 1 + 'multi-code info'. Note that 'code number'-1+'multi-code info' will not be allowed to exceed 'Spreading factor - 1'
>>Code number (for PDSCH code start)	MP		Integer(0..Spreading factor-1)	
>>Code number (for PDSCH code stop)	MP		Integer(0..Spreading factor-1)	
>TFCI range				
>>DSCH mapping	MP	1 to < maxPDSC H-TFCIgroups >		
>>>Max TFCI(field2) value	MP		Integer(1..1023)	This is the maximum value in the range of TFCI(field 2) values for which the specified PDSCH code applies
>>>Spreading factor (for PDSCH code)	MP		Integer(4, 8, 16, 32, 64, 128, 256)	At least 1 spare value needed Criticality: reject is needed
>>>Code number (for PDSCH code)	MP		Integer(0..Spreading factor-1)	
>>>multi-code info	MP		Integer(1..16)	Semantics as described for this parameter above
>Explicit				
>>PDSCH code info	MP	1 to < maxTFCI-2-Combs >		The first instance of the parameter PDSCH code corresponds to TFCI (field2) = 0, the second to TFCI(field 2) = 1 and so on.
>>>Spreading factor (for PDSCH code)	MP		Integer(4, 8, 16, 32, 64, 128, 256)	At least 1 spare value needed Criticality: reject is needed
>>>Code number (for PDSCH code)	MP		Integer(0..Spreading factor-1)	
>>>multi-code info	MP		Integer(1..16)	Semantics as described for this parameter above
>Replace				This choice is made if the PDSCH code(s) associated with a given value of TFCI(field 2) is to be replaced.
>>Replaced PDSCH code	MP	1 to < maxTFCI-2-Combs >		Identity of the PDSCH code(s) to be used for the specified value of TFCI(field 2). These code identity(s) replace any that had been specified before
>>>TFCI (field 2)	MP		Integer (0..1023)	Value of TFCI(field 2) for which PDSCH code mapping will be changed
>>>Spreading factor (for PDSCH code)	MP		Integer(4, 8, 16, 32, 64, 128, 256)	
>>>Code number (for PDSCH code)	MP		Integer(0..Spreading factor-1)	

Information Element/Group name	Need	Multi	Type and reference	Semantics description
>>>multi-code info	MP		Integer(1..16)	Semantics as described for this parameter above

10.3.6.43 PDSCH info

NOTE: Only for TDD.

Information Element/Group name	Need	Multi	Type and reference	Semantics description
TFCS ID	MD		Integer(1..8)	TFCS to be used. Default value is 1.
Common timeslot info	OP		Common timeslot info 10.3.6.9	
PDSCH timeslots and codes	OP	1 to <maxTS>	Downlink Timeslots and Codes 10.3.6.31	Default is to use the old timeslots and codes.

10.3.6.44 PDSCH Power Control info

NOTE: Only for TDD.

Information Element/Group name	Need	Multi	Type and reference	Semantics description
TPC Step Size	OP		Integer (1, 2, 3)	In dB
UL CCTrCH TPC List	MD	1..<maxCC TrCH>		UL CCTrCH identities for TPC commands associated with this DL CCTrCH. Default is previous list or all defined UL CCTrCHs
>UL TPC TFCS Identity	MP		Transport Format Combination Set Identity 10.3.5.21	

10.3.6.45 PDSCH system information

NOTE: Only for TDD.

Information Element/Group name	Need	Multi	Type and reference	Semantics description
PDSCH information	MP	1 to <maxPDSCH>		
>PDSCH Identity	MP		Integer(1..Hi PDSCHIdentities)	
>PDSCH info	MP		PDSCH info 10.3.6.43	
>SFN Time Info	CH-Block17		SFN Time Info 10.3.6.74	
>DSCH TFS	OP		Transport format set 10.3.5.23	
>DSCH TFCS	OP		Transport Format Combination Set 10.3.5.20	

Condition	Explanation
Block17	This IE is absent in System Information Block 17. Otherwise it is optional.

10.3.6.46 PDSCH with SHO DCH Info

NOTE: Only for FDD

Information Element/Group name	Need	Multi	Type and reference	Semantics description
DSCH radio link identifier	MP		Integer(0..511)	This parameter indicates on which radio link the user will be allocated resource on the DSCH. The CPICH scrambling code will be used for this purpose.
TFCI Combining set	OP			This is used to indicate which of the downlink TFCI(field 2) transmissions made on the DPCCHs within the active set should be soft combined on the physical layer. This parameter may only be sent if there is a 'hard' split of the TFCI field and in this case the sending of the parameter is optional.
Radio link identifier	OP	1 to <maxRL>		
>Primary CPICH info	MP		Primary CPICH info 10.3.6.59	The CPICH scrambling code is used for this purpose

10.3.6.47 Persistence scaling factors

This IE defines scaling factors associated with ASC 2 – ASC 7 (multiplicity corresponds to the number of PRACH partitions minus 2) to be applied to the dynamic persistence value. This IE shall not be present in system information if only ASC 0 and ASC 1 are defined. If it is not present for ASC >1, default persistence scaling factor 1 shall be used (see Sec. 8.5.14).

Information Element/Group name	Need	Multi	Type and reference	Semantics description
Access Service Class		1 to maxASCpe rsist		
> Persistence scaling factor	MP		Real(0.9..0.2, by step of 0.1)	Scaling factors in the range 0,...,1

10.3.6.48 PICH Info

Information Element/Group name	Need	Multi	Type and reference	Semantics description
CHOICE mode	MP			
>FDD				
>>Secondary scrambling code	MD		Secondary scrambling code 10.3.6.73	Default is the same scrambling code as for the Primary CPICH
>>Channelization code	MP		Integer(0..255)	SF is fixed and equal to 256
>>Number of PI per frame	MP		Integer (18, 36 72 144)	
>>STTD indicator	MP		STTD Indicator 10.3.6.77	
>TDD				
>>Channelization code	MD		Enumerated ((16/1)...(16/16))	Default value is the channelization code used by the SCCPCH carrying the associated PCH.
>>Timeslot	MD		Timeslot number 10.3.6.81	Default value is the timeslot used by the SCCPCH carrying the associated PCH.
>>Burst type	MP		Enumerated (Typ1,Typ2)	
>>Midamble shift	MD		Midamble shift 10.3.6.40	Default value is the midamble shift used by the SCCPCH carrying the associated PCH.
>>Repetition period/length	MD		Enumerated((4/2),(8/2), (8/4),(16/2), (16/4), (32/2),(32/4), (64/2),(64/4))	Default value is "(64/2)".
>>Offset	MP		Integer (0...Repetition period -1)	SFN mod Repetition period = Offset.
>>Paging indicator length	MD		Integer (4, 8, 16)	Indicates the length of one paging indicator in Bits. Default value is 4.
>>NGAP	MD		Integer(2, 4, 8)	Number of frames between the last frame carrying PICH for this Paging Occasion and the first frame carrying paging messages for this Paging Occasion. Default value is 4.
>>NPCH	MD		Integer(1 .. 8)	Number of paging groups. Default value is 2.

10.3.6.49 PICH Power offset

NOTE: Only for FDD.

This is the power transmitted on the PICH minus power of the Primary CPICH.

Information Element/Group name	Need	Multi	Type and reference	Semantics description
PICH Power offset	MP		Integer(-10 .. +5)	Offset in dB

10.3.6.50 PRACH Channelization Code

NOTE: Only for TDD.

Information Element/Group name	Need	Multi	Type and reference	Semantics description
CHOICE SF	MP			
>SF16				
>>Channelization Code List	MP	1 to 8		
>>>Channelization code	MP		Enumerated ((16/1)...(16/16))	1:1 mapping between spreading code and midamble shift
>SF8				
>>Channelization Code List	MP	1 to 8		
>>>Channelization Code	MP		Enumerated((8/1)..(8/8))	

10.3.6.51 PRACH info (for RACH)

Information Element/Group name	Need	Multi	Type and reference	Semantics description
CHOICE mode	MP			
>FDD				
>> Available Signature	MP		Bitstring(16)	(Note1) 0000000000000001:Signature 0 0000000000000010:Signature 1 0000000000000011:Signature 0&1: 1111111111111111:Signature 0to15
>>Available SF	MP		Integer (32,64,128,256)	In chips per symbol Defines the smallest permitted SF (i.e. the maximum rate)
>>Preamble scrambling code number	MP		Integer (0 .. 15)	Identification of scrambling code see TS 25.213
>>Puncturing Limit	MP		Real(0.40..1.00 by step of 0.04)	
>> Available Sub Channel Number	MP		Bitstring(12)	(Note2) 000000000001:SubChNumber 0 000000000010:SubChNumber 1 000000000011:SubChNumber 0&1 ...: 111111111111:SubChNumber 0to11
>TDD				
>>Timeslot	MP		Timeslot number 10.3.6.81	
>>PRACH Channelization Code	MP		PRACH Channelization Code 10.3.6.50	
>>PRACH Midamble	OP		Enumerated (Direct, Direct/Inverted)	Direct or direct and inverted midamble are used for PRACH

NOTE 1: Each bit is 0 or 1 to indicate available signature_x, x= 0 to 15.

NOTE 2: Each bit is 0 or 1 to indicate available sub channel number _x, x= 0 to 11.

10.3.6.52 PRACH partitioning

Information Element/Group name	Need	Multi	Type and reference	Semantics description
CHOICE mode				
>FDD				
>>Access Service class	MP	1 to maxASC		
>>>ASC Setting	MD		ASC setting 10.3.6.5	The default values are same as the previous ASC. If the "default" is used for the first ASC, the default values are all available signatures and "all available sub-channels".
>>TDD				
>>>Access Service class List	MP	1 to maxASC		List of Access Service classes
>>>>Access service class Index	MP		Integer(1..8)	
>>>>Repetition Period	MD		Integer(1, 2, 4, 8)	Default value is continuous. Value 1 indicates continuous allocation
>>>>Offset	MP		Integer(0..Repetition Period - 1)	Note that this is empty if repetition period is set to 1

The following description applies to FDD only.

The list of available signatures is renumbered from signature index 0 to signature index N-1, where N is the number of available signatures, starting with the lowest available signature number and continuing in sequence, in the order of increasing signature numbers.

- List of available signatures : 16 or less signatures are available.
- Ex : only signatures 0, 5, 10 and 15 are available, then :
- Signature 0 is : available signature index 0
- Signature 5 is : available signature index 1
- Signature 10 is : available signature index 2
- Signature 15 is : available signature index 3

The list of available access-slot sub-channels is renumbered from access-slot sub-channel index 0 to access-slot sub-channel index M-1, where M is the number of available access-slot sub-channels, starting with the lowest available access-slot sub-channel number and continuing in sequence, in the order of increasing access-slot sub-channel numbers.

- List of available Access Slot channels : 12 or less sub-channels are available.
- Ex : only sub-channels 0,1; 4,5; 8,9 are present, then :
- Sub-channel 0 is : available sub-channel index 0
- Sub-channel 1 is : available sub-channel index 1
- Sub-channel 4 is : available sub-channel index 2
- Sub-channel 5 is : available sub-channel index 3
- Sub-channel 8 is : available sub-channel index 4
- Sub-channel 9 is : available sub-channel index 5

One ASC has access to all the access-slot sub-channels between the Available sub-channel Start Index and the Available sub-channel End Index, and to all the signatures between the Available signature Start Index and the Available signature End Index.

NOTE: The above text may eventually be moved to a more appropriate location.

10.3.6.53 PRACH power offset

NOTE: Only for FDD.

Information Element/Group name	Need	Multi	Type and reference	Semantics description
Power Ramp Step	MP		Integer (1..8)	Power step when no acquisition indicator is received in dB
Preamble Retrans Max	MP		Integer (1..64)	Maximum number of preambles in one preamble ramping cycle

10.3.6.54 PRACH system information list

Information element	Need	Multi	Type and reference	Semantics description
PRACH system information	MP	1 .. <maxPRACH>		
>PRACH info	MP		PRACH info (for RACH) 10.3.6.51	
>Transport channel identity	MP		Transport channel identity 10.3.5.18	
>RACH TFS	MD		Transport format set 10.3.5.23	Default value is the value of "RACH TFS" for the previous PRACH in the list (note : the first occurrence is then MP)
>RACH TFCS	MD		Transport Format Combination Set 10.3.5.20	Default value is the value of "RACH TFCS" for the previous PRACH in the list (note : the first occurrence is then MP)
>PRACH partitioning	MD		PRACH partitioning 10.3.6.45	Default value is the value of "PRACH partitioning" for the previous PRACH in the list (note : the first occurrence is then MP)
>Persistence scaling factors	OP		Persistence scaling factors 10.3.6.47	If this IE is absent, value is the value of "Persistence scaling factors" for the previous PRACH in the list if value exists
>AC-to-ASC mapping	OP		AC-to-ASC mapping 10.3.6.1	Only present in SIB 5 If this IE is absent, value is the value of "Persistence scaling factors" for the previous PRACH in the list if value exists
>CHOICE mode	MP			
>>FDD				
>>>Primary CPICH TX power	MD		Primary CPICH TX power 10.3.6.60	Default value is the value of "Primary CPICH TX power" for the previous PRACH in the list (note : the first occurrence is then MP)
>>>Constant value	MD		Constant value 10.3.6.10	Default value is the value of "Constant value" for the previous PRACH in the list (note : the first occurrence is then MP)
>>>PRACH power offset	MD		PRACH power offset 10.3.6.53	Default value is the value of "PRACH power offset" for the previous PRACH in the list (note : the first occurrence is then MP)
>>>RACH transmission parameters	MD		RACH transmission parameters 10.3.6.66	Default value is the value of "RACH transmission parameters" for the previous PRACH in the list (note : the first occurrence is then MP)
>>>AICH info	MD		AICH info 10.3.6.2	Default value is the value of "AICH info" for the previous PRACH in the list (note : the first occurrence is then MP)
>>TDD				(no data)

NOTE: If the setting of the PRACH information results in that a combination of a signature, preamble scrambling code and subchannel corresponds to a RACH with a TTI of both 10 ms and 20 ms, then for that combination only the TTI of value 10 ms is valid.

10.3.6.55 Predefined PhyCH configuration

This information element concerns a pre- defined configuration of physical channel parameters.

Information Element/Group name	Need	Multi	Type and Reference	Semantics description
Uplink radio resources				
Uplink DPCH info	MP		Uplink DPCH info Pre 10.3.6.88	
Downlink radio resources				
Downlink information common for all radio links			Downlink information common for all radio links Pre 10.3.6.25	

10.3.6.56 Primary CCPCH info

Information Element/Group name	Need	Multi	Type and reference	Semantics description
CHOICE mode	MP			
>FDD				
>>TX Diversity indicator	MP		Boolean	
>TDD				
>>CHOICE SyncCase	OP			
>>>Sync Case 1				
>>>>Timeslot	MP		Integer (0..14)	PCCPCH timeslot
>>>Sync Case 2				
>>>>Timeslot	MP		Integer(0..6)	
>>Cell parameters ID	OP		Cell parameters Id 10.3.6.8	The Cell parameters ID is described in 25.223.
>>Block STTD indicator	MP		Block STTD indicator 10.3.6.6	

10.3.6.57 Primary CCPCH info post

NOTE: Only for TDD

Information Element/Group name	Need	Multi	Type and reference	Semantics description
CHOICE SyncCase	MP			
>Sync Case 1				
>>Timeslot	MP		Integer (0..14)	PCCPCH timeslot
>Sync Case 2				
>>Timeslot	MP		Integer(0..6)	
Cell parameters ID	MP		Cell parameters Id 10.3.6.8	The Cell parameters ID is described in 25.223.
Block STTD indicator	MP		Block STTD indicator 10.3.6.5	

10.3.6.58 Primary CCPCH TX Power

NOTE: Only for TDD.

Information Element/group name	Need	Multi	Type and reference	Semantics description
Primary CCPCH Tx Power	MP		Integer(6..43)	In dBm

10.3.6.59 Primary CPICH info

NOTE: Only for FDD.

Information Element/Group name	Need	Multi	Type and reference	Semantics description
Primary scrambling code	MP		Integer(0..511)	

10.3.6.60 Primary CPICH Tx power

NOTE: Only for FDD.

Information Element/Group name	Need	Multi	Type and reference	Semantics description
Primary CPICH Tx Power	MP		Integer(-10..50)	At least 3 spare values are needed for future extensions with criticality reject

10.3.6.61 Primary CPICH usage for channel estimation

NOTE: Only for FDD.

Information Element/Group name	Need	Multi	Type and Reference	Semantics description
Primary CPICH usage for channel estimation	MP		Enumerated(Primary CPICH may be used, Primary CPICH shall not be used)	

10.3.6.62 PUSCH info

NOTE: Only for TDD.

Information Element/Group name	Need	Multi	Type and reference	Semantics description
TFCS ID	MD		Integer(1..8)	Default value is 1
Common timeslot info	OP		Common timeslot info 10.3.6.9	
PUSCH timeslots and codes	OP	1 to <maxTS>	Uplink Timeslots and Codes 10.3.6.92	

10.3.6.63 PUSCH Capacity Allocation info

NOTE: Only for TDD.

Information Element/Group name	Need	Multi	Type and reference	Semantics description
CHOICE PUSCH allocation	MP			
>PUSCH allocation pending				(no data)
>PUSCH allocation assignment				
>>PUSCH allocation period info	MP		Allocation Period Info 10.3.6.4	
>>PUSCH power control info	OP		PUSCH power control info 10.3.6.64	
>>TFCS ID	MD		Integer(1..8)	Default is 1.
>>CHOICE Configuration	MP			
>>>Old configuration				
>>>>PUSCH Identity	MP		Integer(1..Hi PUSCHIdentities)	
>>>New configuration				
>>>>PUSCH info	MP		PUSCH info 10.3.6.62	
>>>>PUSCH Identity	OP		Integer(1..maxPDSCHIdentity)	

10.3.6.64 PUSCH power control info

NOTE: Only for TDD.

Interference level measured for a frequency at the UTRAN access point used by UE to set PUSCH output power.

Information Element/Group name	Need	Multi	Type and reference	Semantics description
UL target SIR	MP		Real (-11 .. 20 by step of 0.5)	in dB

10.3.6.65 PUSCH system information

NOTE: Only for TDD.

Information Element/Group name	Need	Multi	Type and reference	Semantics description
PUSCH information	MP	1 to <maxPUSCH>		
>PUSCH Identity	MP		Integer(1..Hi PUSCHIdentities)	
>PUSCH info	MP		PUSCH info 10.3.6.62	
>SFN Time Info	CH-Block17		SFN Time Info 10.3.6.74	
>USCH TFS	OP		Transport format set 10.3.5.23	
>USCH TFCS	MP		Transport Format Combination	

			Set 10.3.5.20	
--	--	--	------------------	--

Condition	Explanation
Block17	This IE is absent in System Information Block 17. Otherwise it is optional.

10.3.6.66 RACH transmission parameters

NOTE: Only for FDD.

Information Element/Group name	Need	Multi	Type and reference	Semantics description
Mmax	MP		Integer(1..32)	Maximum number of preamble cycles
NB01min	MP		Integer(0..50)	Sets lower bound for random back-off
NB01max	MP		Integer(0..50)	Sets upper bound for random back-off

10.3.6.67 Radio link addition information

Information Element/Group name	Need	Multi	Type and reference	Semantics description
Primary CPICH info	MP		Primary CPICH info 10.3.6.59	
Downlink DPCH info for each RL	MP		Downlink DPCH info for each RL 10.3.6.20	
TFCI combining indicator	OP		TFCI combining indicator 10.3.6.79	
SCCPCH Information for FACH	OP		SCCPCH Information for FACH 10.3.6.69	Note 1

NOTE 1: These IEs are present when the UE needs to listen to system information on FACH in CELL_DCH state.

10.3.6.68 Radio link removal information

Information Element/Group name	Need	Multi	Type and reference	Semantics description
Primary CPICH info	MP		Primary CPICH info 10.3.6.59	

10.3.6.69 SCCPCH Information for FACH

Secondary CCPCH info	MP		Secondary CCPCH info 10.3.6.70	
TFCS	MP		Transport format set 10.3.5.23	For FACHs and PCH
FACH/PCH information	MP	1 to <maxFAC HPCH>		
>TFS	MP		Transport format set 10.3.5.23	For each FACHs and PCH
References to system information blocks	MP	1 to <maxSIB-FACH>		
>Scheduling information	MP		Scheduling information 10.3.8.12	

10.3.6.70 Secondary CCPCH info

Information Element/Group name	Need	Multi	Type and reference	Semantics description
CHOICE mode	MP			
>FDD				
>>Primary CPICH usage for channel estimation	MP		Primary CPICH usage for channel estimation 10.3.6.61	
>>Secondary CPICH info	OP		Secondary CPICH info 10.3.6.72	
>>Secondary scrambling code	MD		Secondary scrambling code 10.3.6.73	Default is the same scrambling code as for the Primary CPICH
>>STTD indicator	MD		STTD Indicator 10.3.6.77	Default value is "TRUE"
>>Spreading factor	MP		Integer(4, 8, 16, 32, 64, 128, 256)	
>>Code number	MP		Integer(0..Spreading factor - 1)	
>>Pilot symbol existence	MD		Boolean	TRUE means the existence. Default value is "TRUE"
>>TFCI existence	MD		Boolean	TRUE means the existence. Default value is "TRUE"
>>Fixed or Flexible Position	MD		Enumerated (Fixed, Flexible)	Default value is "Flexible"
>>Timing Offset	MD		Integer(0..38144 by step of 256)	Chip Delay of the Secondary CCPCH relative to the Primary CCPCH. Default value is 0.
>TDD				
>>Offset	MD		Integer (0..Repetition Period -1)	SFN modulo Repetition period = offset. Repetition period is the one indicated in the accompanying Common timeslot info IE
>>Common timeslot info	MP		Common timeslot info 10.3.6.9	
>>Individual timeslot info	MP		Individual timeslot info 10.3.6.36	
>>Code List	MP	1..<maxCode sCount>		
>>>Channelization Code	MP		Enumerated((16/1)..(16/16))	

10.3.6.71 Secondary CCPCH system information

Information element	Need	Multi	Type and reference	Semantics description
Secondary CCPCH system information	MP	1 to <maxSCCPCH>		
>Secondary CCPCH info	MP		Secondary CCPCH info 10.3.6.70	Note 1
>TFCS	MD		Transport format set 10.3.5.23	For FACHs and PCH Default value is the value of "TFCS" for the previous SCCPCH in the list (note : the first occurrence is then MP)
>FACH/PCH information	MD	1 to <maxFACHPCH>		Default value is the value of "FACH/PCH" for the previous SCCPCH in the list (note : the first occurrence is then MP)
>>Transport channel identity	MP		Transport channel identity 10.3.5.18	
>>TFS	MP		Transport format set 10.3.5.23	For each FACH and PCH Note 2
>>CTCH indicator	MP		Boolean	The value "TRUE" indicates that a CTCH is mapped on the FACH, and "FALSE" that no CTCH is mapped.
>PICH info	OP		PICH info 10.3.6.48	PICH info is present only when PCH is multiplexed on Secondary CCPCH

NOTE 1: The secondary CCPCHs carrying a PCH shall be listed first.

NOTE 2: TFS for PCH shall be the first "FACH/PCH information" in the list if a PCH exists for the respective secondary CCPCH.

10.3.6.72 Secondary CPICH info

NOTE: Only for FDD.

Information Element/Group name	Need	Multi	Type and reference	Semantics description
Secondary scrambling code	MD		Secondary scrambling code 10.3.6.73	Default is the same scrambling code as for the Primary CPICH
Channelization code	MP		Integer(0..255)	SF=256

10.3.6.73 Secondary scrambling code

Information Element/Group name	Need	Multi	Type and reference	Semantics description
Secondary scrambling code	MP		Integer(1..15)	At least 1 spare value needed Criticality: reject is needed

10.3.6.74 SFN Time info

Information Element/Group name	Need	Multi	Type and reference	Semantics description
Activation time SFN	MP		Integer (0..4095)	System frame number start of the physical channel existence.
Duration	MP		Integer(1..4096)	Total number of frames the physical channel will exist.

10.3.6.75 SSdT cell identity

NOTE: Only for FDD.

This IE is used to associate a cell identity with a given radio link.

Information Element/Group name	Need	Multi	Type and reference	Semantics description
SSdT cell id	MP		Enumerated (a, b, c, d, e, f, g, h)	

10.3.6.76 SSdT information

NOTE: Only for FDD.

This information element indicates the status (e.g. initiated/terminated) of the Site Selection.

Diversity Transmit power control (SSdT). It is used to change the SSdT status. The parameter 'code word set' indicates how cell identities are coded (using many bits or few, values are long, medium, or short).

Information Element/Group name	Need	Multi	Type and reference	Semantics description
S field	MP		Integer (1, 2)	in bits
Code Word Set	MP		Enumerated (long, medium, short, SSdT off)	

NOTE: These parameters shall be set optionally associated with DL DPCH info but not for each RL.

10.3.6.77 STTD indicator

Indicates whether STTD is used or not.

Information Element/Group name	Need	Multi	Type and reference	Semantics description
STTD Indicator	MP		Boolean	TRUE means that STTD is used

10.3.6.78 TFC Control duration

Information Element/Group name	Need	Multi	Type and reference	Semantics description
TFC Control duration	MP		Integer (1, 2, 4, 8, 16, 24, 32, 48, 64, 128, 192, 256, 512)	Defines the period in multiples of 10 ms frames for which the defined TFC sub-set is to be applied. At least 3 spare values for future extensions with criticality reject are needed.

10.3.6.79 TFCI Combining Indicator

NOTE: Only for FDD.

This IE indicates whether the TFCI (field 2) which will be transmitted on the DPCCCH of a newly added radio link should be soft combined with the others in the TFCI (field 2) combining set. This IE can only be sent when the UE is in CELL_DCH state with a DSCH transport channel assigned and when there is a 'hard' split in the TFCI field (such that TFCI1 and TFCI2 have their own separate block coding).

Information Element/Group name	Need	Multi	Type and reference	Semantics description
TFCI combining indicator	MP		Boolean	TRUE means that TFCI is combined

10.3.6.80 TGPSI

Information Element/Group name	Need	Multi	Type and reference	Semantics description
TGPSI	MP		Integer(1..MaxTGPS)	Transmission Gap Pattern Sequence Identifier Establish a reference to the compressed mode pattern sequence. Up to <MaxTGPS> simultaneous compressed mode pattern sequences can be used.

10.3.6.81 Time info

Information Element/Group name	Need	Multi	Type and reference	Semantics description
Activation time	MD		Activation time 10.3.3.1	Frame number start of the physical channel existence. Default value is "Now"
Duration	MD		Integer(1..4096, infinite)	Total number of frames the physical channel will exist. Default value is "infinite".

10.3.6.82 Timeslot number

Information Element/Group name	Need	Multi	Type and reference	Semantics description
Timeslot number	MP		Integer(0..14)	Timeslot within a frame

10.3.6.83 TPC combination index

NOTE: Only for FDD.

Information Element/Group name	Need	Multi	Type and reference	Semantics description
TPC combination index	MP		Integer(0..5)	Radio links with the same index have TPC bits, which for the UE are known to be the same.

10.3.6.84 TX Diversity Mode

NOTE: Only for FDD.

Information Element/Group name	Need	Multi	Type and reference	Semantics description
Tx diversity Mode	MP		Enumerated (none, STTD, closed loop mode1, closed loop mode2)	

10.3.6.85 UL interference

Information Element/Group name	Need	Multi	Type and reference	Semantics description
UL interference	MP		Integer (-110..-70)	In dBm At least 23 spare values with criticality reject are needed

NOTE: In TDD, this IE is a timeslot specific value.

10.3.6.86 Uplink DPCH info

Information Element/Group name	Need	Multi	Type and reference	Semantics description
Uplink DPCH power control info	OP		Uplink DPCH power control info 10.3.6.89	
CHOICE mode	MP			
>FDD				
>>Scrambling code type	MP		Enumerated (short, long)	
>>Scrambling code number	MP		Integer(0..16777215)	
>>Number of DPDCH	MD		Integer(2..maxDPDCH)	Default value is 1. Number of DPDCH is 1 in HANDOVER TO UTRAN COMMAND
>>Spreading factor	MP		Integer(4, 8, 16, 32, 64, 128, 256)	SF of the channelization code for data part
>>TFCl existence	MD		Boolean	TRUE means existence. Default value is "TRUE"
>>Number of FBI bits	CH		Integer (1, 2)	In bits. Number of FBI bits is needed if SSdT or FB Mode Transmit Signalling is supported.
>>Puncturing Limit	MP		Real(0.40 ..1 by step of 0.04)	
>TDD				
>>Uplink Timing Advance Control	OP		Uplink Timing Advance Control 10.3.6.94	
>>UL CCTrCH List	MP	1 to <maxCCTrCH>		
>>>TFCS ID	MD		Integer(1..8)	Default value is 1.
>>>Time info	MP		Time info 10.3.6.81	
>>>Common timeslot info	MD		Common timeslot info 10.3.6.9	Default is the current Common timeslot info
>>>Uplink DPCH timeslots and codes	MD		Uplink Timeslots and Codes 10.3.6.92	Default is to use the old timeslots and codes.

Condition	Explanation
Single	This IE is included if IE "Number of DPDCH" is "1"

10.3.6.87 Uplink DPCH info Post

Information Element/Group name	Need	Multi	Type and reference	Semantics description
Uplink DPCH power control info	MP		Uplink DPCH power control info Post 10.3.6.90	
CHOICE mode	MP			
>FDD				
>>Scrambling code type	MP		Enumerated(short, long)	
>>Reduced scrambling code number	MP		Integer(0..8191)	Sub-range of values for initial use upon handover to UTRAN.
>>Spreading factor	MP		Integer(4, 8, 16, 32, 64, 128, 256)	SF of the channelization code for data part There is only one DPDCH for this case
>TDD				
>>Uplink Timing Advance Control	OP		Uplink Timing Advance Control 10.3.6.94	
>>Uplink DPCH timeslots and codes	MP		Uplink Timeslots and Codes 10.3.6.92	

10.3.6.88 Uplink DPCH info Pre

Information Element/Group name	Need	Multi	Type and reference	Semantics description
Uplink DPCH power control info	OP		Uplink DPCH power control info Pre 10.3.6.91	
CHOICE mode	MP			
>FDD				
>>TFCI existence	MP		Boolean	TRUE means existence. Default value is "TRUE"
>>Puncturing Limit	MP		Real(0.40 ..1 by step of 0.04)	
>TDD				
>>Common timeslot info	MP		Common Timeslot Info 10.3.6.9	

Condition	Explanation
Single	This IE is included if IE "Number of DPDCH" is "1"

10.3.6.89 Uplink DPCH power control info

Parameters used by UE to set DPCH initial output power and to use for closed-loop power control in FDD and parameters for uplink open loop power control in TDD.

Information Element/Group name	Need	Multi	Type and reference	Semantics description
CHOICE mode	MP			
>FDD				
>>DPCCH Power offset	MP		Integer(-164,...-6 by step of 2)	In dB
>>PC Preamble	MP		Integer (0, 15)	
>>Power Control Algorithm	MP		Enumerated (algorithm 1, algorithm 2)	Specifies algorithm to be used by UE to interpret TPC commands
>>TPC step size	CV algo		Integer (1, 2)	In dB
>TDD				
>>UL target SIR	MP		Real (-11 .. 20 by step of 0.5dB)	In dB
>>CHOICE UL OL PC info	MP			
>>>Broadcast UL OL PC info			Null	No data
>>>Individually Signalled	OP			
>>>>Individual timeslot interference info	MP	1 to <maxTS>		
>>>> Individual timeslot interference	MP		Individual timeslot interference 10.3.6.37	
>>>>DPCH Constant Value	OP		Constant Value 10.3.6.10	Quality Margin
>>>>Primary CCPCH Tx Power	OP		Primary CCPCH Tx Power 10.3.6.58	For Pathloss Calculation

Condition	Explanation
algo	The IE is mandatory if "Power Control Algorithm" is set to "algorithm 1", otherwise the IE is not needed

10.3.6.90 Uplink DPCH power control info Post

Parameters used by UE to set DPCH initial output power and to use for closed-loop power control.

Information Element/Group name	Need	Multi	Type and reference	Semantics description
CHOICE mode	MP			
>FDD				
>>Power Control Algorithm	MP		Enumerated (algorithm 1, algorithm 2)	Specifies algorithm to be used by UE to interpret TPC commands
>>TPC step size	CV algo		Integer (1, 2)	In dB
>TDD				
>>UL target SIR	MP		Real (-11 .. 20 by step of 0.5dB)	In dB
>>UL Timeslot Interference	MP		UL Interference 10.3.6.85	

Condition	Explanation
algo	The IE is mandatory if "Power Control Algorithm" is set to "algorithm 1", otherwise the IE is not needed

10.3.6.91 Uplink DPCH power control info Pre

Parameters used by UE to set DPCH initial output power and to use for closed-loop power control in FDD and parameters for uplink open loop power control in TDD.

Information Element/Group name	Need	Multi	Type and reference	Semantics description
CHOICE mode	MP			
>FDD				
>>DPCCH Power offset	MP		Integer(-164..-6 by step of 2)	In dB
>>PC Preamble	MP		Integer (0, 15)	
>TDD				(No data)
>>DPCH Constant Value	MP		Constant Value 10.3.6.10	Quality Margin

Condition	Explanation
Algo	The IE is mandatory if "Power Control Algorithm" is set to "algorithm 1", otherwise the IE is not needed

10.3.6.92 Uplink Timeslots and Codes

NOTE: Only for TDD

Information Element/Group name	Need	Multi	Type and reference	Semantics description
First Individual timeslot info	MP		Individual timeslot info 10.3.6.36	Individual timeslot info for the first timeslot used by the physical layer.
First timeslot Code List	MP	1..2		Code list used in the timeslot. given in First individual timeslot info.
>Channelization Code	MP		Enumerated((1/1),(2/1),(2/2),(4/1)..(4/4),(8/1)..(8/8),(16/1)..(16/16))	
CHOICE more timeslots	MP			
>No more timeslots				(no data)
>Consecutive timeslots				
>>Number of additional timeslots	MP		Integer(1..maxTS-1)	The timeslots used by the physical layer shall be timeslots: N mod maxTS (N+1) mod maxTS ... (N+k) mod maxTS in that order, where N is the timeslot number in the First individual timeslot info and k the Number of additional timeslots. The additional timeslots shall use the same parameters (e.g. channelization codes, midamble shifts etc.) as the first timeslot.
>Timeslot list				
>>Additional timeslot list	MP	1 to <maxTS-1>		The first instance of this parameter corresponds to the timeslot that shall be used second by the physical layer, the second to the timeslot that shall be used third and so on.
>>>CHOICE parameters	MP			
>>>>Same as last				
>>>>>Timeslot number	MP		Timeslot Number 10.3.6.81	This physical layer shall use the same parameters (e.g. channelization codes, midamble shifts etc.) for this timeslot as for the last one.
>>>>>New parameters				
>>>>>Individual timeslot info	MP		Individual timeslot info 10.3.6.36	
>>>>>Code List	MP	1..2		
>>>>>>Channelization Code	MP		Enumerated((1/1),(2/1),(2/2),(4/1)..(4/4),(8/1)..(8/8),(16/1)..(16/16))	

10.3.6.93 Uplink Timing Advance

NOTE: Only for TDD.

Information Element/Group name	Need	Multi	Type and reference	Semantics description
UL Timing Advance	MP		Integer (0..63)	Absolute timing advance value to be used to avoid large delay spread at the NodeB

10.3.6.94 Uplink Timing Advance Control

NOTE: Only for TDD

Information Element/Group name	Need	Multi	Type and reference	Semantics description
CHOICE Timing Advance	MP			
>Disabled			Null	Indicates that no timing advance is applied
>Enabled				
>>UL Timing Advance	MD		Uplink Timing Advance 10.3.6.93	Absolute timing advance value to be used to avoid large delay spread at the NodeB. Default value is the existing value for uplink timing advance.
>>Activation Time	OP		Activation Time 10.3.3.1	Frame number timing advance is to be applied. This IE is required when a new UL Timing Advance adjustment is specified and Activation Time is not otherwise specified in the RRC message.

10.3.7 Measurement Information elements

10.3.7.1 Additional measurements list

Information Element/Group name	Need	Multi	Type and reference	Semantics description
Additional measurements	MP	1 to <MaxAdditionalMeas>		
>Additional measurement identity	MP		Measurement identity number 10.3.73	

10.3.7.2 Cell info

Includes non-frequency related cell info used in the IE "inter-frequency cell info list" and "intra frequency cell info list".

Information Element/Group name	Need	Multi	Type and reference	Semantics description
Cell individual offset	MD		Real(-10..10 by step of 0.5)	In dB Default value is 0 dB Used to offset measured quantity value
Reference time difference to cell	OP		Reference time difference to cell 10.3.7.85	In chips. This IE is absent for serving cell.
CHOICE mode	MP			
>FDD				
>>Primary CPICH info	OP		Primary CPICH info 10.3.6.59	This IE is absent only if measuring RSSI only (broadband measurement.)
>>Primary CPICH Tx power	OP		Primary CPICH Tx power 10.3.6.60	Required if calculating pathloss.
>>Read SFN indicator	MP		Boolean	TRUE indicates that read of SFN is requested for the target cell
>>TX Diversity Indicator	MP		Boolean	
>TDD				
>>Primary CCPCH info	MP		Primary CCPCH info 10.3.6.56	
>>Primary CCPCH TX power	OP		Primary CCPCH TX power 10.3.6.58	
>> Timeslot list	OP	1 to <maxTS>		The UE shall report Timeslot ISCP values according the order of the listed Timeslot numbers
>>>Timeslot number	MP		Integer (0...14)	Timeslot numbers, for which the UE shall report Timeslot ISCP
>>>Burst Type	MD		Enumerated (Type1, Type2)	Use for Timeslot ISCP measurements only. Default value is "Type1"
Cell Selection and Re-selection Info	CV-BCHopt		Cell Selection and Re-selection for SIB11/12Info 10.3.2.4	Only when sent in system information. This IE is absent for serving cell. For neighbouring cell, if HCS is not used and all the parameters in cell selection and re-selection info are default value, this IE is absent.

10.3.7.3 Cell measured results

Includes non frequency related measured results for a cell.

Information Element/Group name	Need	Multi	Type and reference	Semantics description
Cell Identity	OP		Cell Identity 10.3.2.2	
SFN-SFN observed time difference	OP		SFN-SFN observed time difference 10.3.7.88	
CFN-SFN observed time difference	OP		CFN-SFN observed time difference 10.3.7.6	Note 2
CHOICE mode	MP			
>FDD				
>>Primary CPICH info	MP		Primary CPICH info 10.3.6.59	
>>CPICH Ec/N0	OP		Integer(-20..0)	In dB
>>CPICH RSCP	OP		Integer(-115..-40)	In dBm
>>Pathloss	OP		Integer(46..158)	In dB
>TDD				
>>Cell parameters Id	MP		Cell parameters Id 10.3.6.8	
>>Primary CCPCH RSCP	OP		Primary CCPCH RSCP info 10.3.7.79	
>>Pathloss	OP		Integer(46..158)	In dB
>> Timeslot list	OP	1 to <maxTS>		
>>>Timeslot ISCP	MP		Timeslot ISCP Info 10.3.7.90	The UE shall report the Timeslot ISCP in the same order as indicated in the cell info

NOTE 1: Feasibility of performing these measurements with compressed mode is unclear.

10.3.7.4 Cell measurement event results

Includes non frequency related cell reporting quantities.

Information Element/Group name	Need	Multi	Type and reference	Semantics description
CHOICE mode	MP			
>FDD				
>>Primary CPICH info	MP	1 to <maxCellMeas>	Primary CPICH info 10.3.6.59	
>TDD				
>>Primary CCPCH info	MP	1 to <maxCellMeas>	Primary CCPCH info 10.3.6.56	

10.3.7.5 Cell reporting quantities

Includes non frequency related cell reporting quantities.

For all boolean types TRUE means inclusion in the report is requested.

Information Element/Group name	Need	Multi	Type and reference	Semantics description
SFN-SFN observed time difference	MP		Enumerated(No report, type 1, type 2)	
CFN-SFN observed time difference	MP		Boolean	
Cell Identity	MP		Boolean	
CHOICE mode	MP			
>FDD				
>>CPICH Ec/N0	MP		Boolean	
>>CPICH RSCP	MP		Boolean	
>>Pathloss	MP		Boolean	
>TDD				
>>Timeslot ISCP	MP		Boolean	
>>Primary CCPCH RSCP	MP		Boolean	
>>Pathloss	MP		Boolean	

10.3.7.6 CFN-SFN observed time difference

The measured time difference to cell indicates the time difference that is measured by UE between RLC Transparent Mode COUNT-C in the UE and the SFN of the target neighbouring cell. It is notified to SRNC by Measurement Report message or Measurement Information Element in other RRC messages

Information Element/Group name	Need	Multi	Type and reference	Semantics description
CHOICE mode	MP			
>FDD				
>>CFN-SFN observed time difference	MP		Integer(0..157286399)	Number of chips
>TDD				
>> CFN-SFN observed time difference	MP		Integer(0..4095)	Number of frames

NOTE: This measurement is only used in TDD when cells are not SFN synchronised

10.3.7.7 Event results

Information Element/Group name	Need	Multi	Type and reference	Semantics description
CHOICE event result	MP			
>Intra-frequency measurement event results			Intra-frequency measurement event results 10.3.7.37	
>Inter-frequency measurement event results			Inter-frequency measurement event results 10.3.7.17	
>Inter-system measurement event results			Inter-system measurement event results 10.3.7.28	For IS-2000 results, include fields of the Pilot Strength Measurement Message from subclause 2.7.2.3.2.5 of TIA/EIA/IS-2000.5
>Traffic volume measurement event results			Traffic volume measurement event results 10.3.7.94	
>Quality measurement event results			Quality measurement event results 10.3.7.82	
>UE internal measurement event results			UE internal measurement event results 10.3.7.103	
>LCS measurement event results			LCS measurement event results 10.3.7.58	

CHOICE event result	Condition under which the given event result is chosen
Intra-frequency measurement event results	If measurement type = intra-frequency measurement
Inter-frequency measurement event results	If measurement type = inter-frequency measurement
Inter-system measurement event results	If measurement type = inter-system measurement
Traffic volume measurement event results	If measurement type = traffic volume measurement
Quality measurement event results	If measurement type = Quality measurement
UE internal measurement event results	If measurement type = UE internal measurement
LCS measurement event results	If measurement type = LCS measurement

10.3.7.8 FACH measurement occasion info

This IE is for FDD only.

Information Element/Group name	Need	Multi	Type and reference	Semantics description
k_UTRA	MP		UTRAN DRX cycle length coefficient 10.3.3.47	Default value is the existing value of UTRAN DRX cycle length coefficient
Other RAT present in inter-system cell info	OP	1 to <maxOther RAT>		
>RAT type	MP		Enumerated(GSM, IS2000)	At least 14 spare values, Criticality: Reject, are needed
>k_Inter_Rat	MP		Integer(0..12)	

10.3.7.9 Filter coefficient

Information Element/Group name	Need	Multi	Type and reference	Semantics description
Filter coefficient	MD		Integer(0, 1, 2, 3, 4, 5, 6, 7, 8, 9, 11, 13, 15, 17, 19)	Default value is 0 At least one, criticality: reject, spare value needed for future extension

10.3.7.10 HCS Cell re-selection information

Information Element/Group name	Need	Multi	Type and reference	Semantics description
Penalty_time	MD		Integer(0, 10, 20, 30, 40, 50, 60)	Default value is 0 which means = not used In seconds
Temporary_offsets	CV-Penalty used			
>Temporary_offset1			Integer(10, 20, 30, 40, 50, 60, 70, infinity)	In seconds
>Temporary_offset2	CV-FDD-Quality-Measure		Integer(10, 20, 30, 40, 50, 60, 70, infinity)	Default value is Temporary_offset1

Condition	Explanation
Penalty used	Not allowed if IE Penalty time equals 'not used' else MP
FDD-Quality-Measure	Presence is not allowed if the IE "Cell_selection_and_reselection_quality_measure" has the value CPICH RSCP, otherwise the IE is mandatory and has a default value.

10.3.7.11 HCS neighbouring cell information

Information Element/Group name	Need	Multi	Type and reference	Semantics description
HCS_PRIO	MD		Integer (0..7)	Default value = 0
QHCS	MD		Integer (-0..99)	Default value = 0
HCS Cell Re-selection Information	OP		HCS Cell Re-selection Information 10.3.7.10	

10.3.7.12 HCS Serving cell information

Information Element/Group name	Need	Multi	Type and Reference	Semantics description
HCS_PRIO	MD		Integer (0..7)	Default value = 0
QHCS	MD		Integer(0..99)	Default value = 0
TCRmax	MD		Integer(0, 30, 60, 120, 180, 240)	[s] Default value is 0 which means = not used
NCR	CV-UE speed detector		Integer(1..16)	Default value = 8
TCrmaxHyst	CV-UE speed detector		Integer(0, 10..70 by step of 10)	[s] Default value is 0 which means = not used

Condition	Explanation
UE Speed detector	Not allowed if TCRmax equals 'not used' else MP

10.3.7.13 Inter-frequency cell info list

Contains the measurement object information for an inter-frequency measurement.

Information Element/Group name	Need	Multi	Type and reference	Semantics description
Removed inter-frequency cells	OP	1 .. <maxCellMeas>		
>Inter-frequency cell id	MP		Integer(0 .. <MaxInterCells>)	
New inter-frequency cells	OP	1 to <maxCellMeas>		
>Inter-frequency cell id	MD		Integer(0 .. <MaxInterCells>)	The first inter-frequency cell in the list corresponds to inter-frequency cell id 0, the second corresponds to inter-frequency cell id 1 etc
>Frequency info	MD		Frequency info 10.3.6.35	Default value is the value of the previous "frequency info" in the list (note : the first occurrence is then MP)
>Cell info	MP		Cell info 10.3.7.2	

10.3.7.14 Inter-frequency event identity

Information Element/Group name	Need	Multi	Type and reference	Semantics description
Inter-frequency event identity	MP		Enumerated(2a, 2b, 2c, 2d, 2e, 2f)	

10.3.7.15 Inter-frequency measured results list

Information Element/Group name	Need	Multi	Type and reference	Semantics description
Inter-frequency measurement results	OP	1 to <maxFreq>		
>Frequency info	MD		Frequency info 10.3.6.35	Default value is the value of the previous "frequency info" in the list (note : the first occurrence is then MP)
>UTRA carrier RSSI	OP		Integer(-95..-30)	In dBm
>Inter-frequency cell measurement results	OP	1 to <maxCellMeas>		
>>Cell measured results	MP		Cell measured results 10.3.7.3	

10.3.7.16 Inter-frequency measurement

Information Element/Group name	Need	Multi	Type and reference	Semantics description
Inter-frequency cell info list	MP		Inter-frequency cell info list 10.3.7.13	Measurement object
Inter-frequency measurement quantity	OP		Inter-frequency measurement quantity 10.3.7.18	
Inter-frequency reporting quantity	OP		Inter-frequency reporting quantity 10.3.7.21	
Reporting cell status	CV-reporting		Reporting cell status 10.3.7.86	
Measurement validity	OP		Measurement validity 10.3.7.76	
Inter-frequency set update	OP		Inter-frequency set update 10.3.7.22	
CHOICE report criteria	MP			
>Intra-frequency measurement reporting criteria			Intra-frequency measurement reporting criteria 10.3.7.39	
>Inter-frequency measurement reporting criteria			Inter-frequency measurement reporting criteria 10.3.7.19	
>Periodical reporting criteria			Periodical reporting criteria 10.3.7.78	
>No reporting				(no data) Chosen when this measurement only is used as additional measurement to another measurement

Condition	Explanation
reporting	This IE is optional if the CHOICE "report criteria" is equal to "periodical reporting criteria" or "No reporting", otherwise the IE is not needed

10.3.7.17 Inter-frequency measurement event results

This IE contains the measurement event results that are reported to UTRAN for inter-frequency measurements.

Information Element/Group name	Need	Multi	Type and reference	Semantics description
Inter-frequency event identity	MP		Inter-frequency event identity 10.3.7.34	
Inter-frequency cells	OP	1 to <maxFreq>		
>Frequency info	MP		Frequency info 10.3.6.35	
>Non frequency related measurement event results	MP		Cell measurement event results 10.3.7.4	

10.3.7.18 Inter-frequency measurement quantity

The quantity the UE shall measure in case of inter-frequency measurement. It also includes the filtering of the measurements.

Information Element/Group name	Need	Multi	Type and reference	Semantics description
CHOICE reporting criteria	MP			
>Intra-frequency reporting criteria				
>>Intra-frequency measurement quantity	MP		Intra-frequency measurement quantity 10.3.7.38	
>Inter-frequency reporting criteria				
>>Filter coefficient	MP		Filter coefficient 10.3.7.9	
>>CHOICE mode	MP			
>>>FDD				
>>>>Measurement quantity for frequency quality estimate	MP		Enumerated(CPICH Ec/N0, CPICH RSCP)	
>>>TDD				
>>>>Measurement quantity for frequency quality estimate	MP		Enumerated(Primary CCPCH RSCP)	

10.3.7.19 Inter-frequency measurement reporting criteria

The triggering of the event-triggered reporting for an inter-frequency measurements. All events concerning inter-frequency measurements are labelled 2x where x is a,b,c..

Event 2a: Change of best frequency.

Event 2b: The estimated quality of the currently used frequency is below a certain threshold and the estimated quality of a non-used frequency is above a certain threshold.

Event 2c: The estimated quality of a non-used frequency is above a certain threshold.

Event 2d: The estimated quality of the currently used frequency is below a certain threshold.

Event 2e: The estimated quality of a non-used frequency is below a certain threshold.

Event 2f: The estimated quality of the currently used frequency is above a certain threshold.

Information Element/Group name	Need	Multi	Type and reference	Semantics description
Parameters required for each event	OP	1 to <maxMeas Event>		
>Inter-frequency event identity	MP		Inter-frequency event identity 10.3.7.14	
>Threshold used frequency	CV – clause 0		Integer(-115..0)	Ranges used depend on measurement quantity. CPICH Ec/No -24..0dB CPICH/Primary CCPCH RSCP -115..-25dBm
>W used frequency	CV – clause 0		Real(0, 0.1..2.0 by step of 0.1)	
>Hysteresis	MP		Real(0, 0.5..14.5 by step of 0.5)	In event 2a, 2b, 2c, 2d, 2e, 2f
>Time to trigger	MP		Time to trigger 10.3.7.89	Indicates the period of time between the timing of event detection and the timing of sending Measurement Report. Time in ms.
>Amount of reporting	MP		Integer(1, 2, 4, 8, 16, 32, 64, infinity)	
>Reporting interval	MP		Integer(0, 250, 500, 1000, 2000, 4000, 8000, 16000)	Indicates the interval of periodical reporting when such reporting is triggered by an event. A zero value indicates that event triggered periodical reporting shall not be applied. Interval in milliseconds
>Reporting cell status	OP		Reporting cell status 10.3.7.86	
>Parameters required for each non-used frequency	OP	1 to <maxFreq >		
>>Threshold non used frequency	CV – clause 1		Integer(-115..0)	Ranges used depend on measurement quantity. CPICH Ec/No -24..0dB CPICH/Primary CCPCH RSCP -115..-25dBm
>>W non-used frequency	CV-clause 1		Real(0, 0.1..2.0 by step of 0.1)	

Condition	Explanation
Clause 0	2a,2b, 2d, or 2f, otherwise the IE is not needed
Clause 1	The IE is mandatory in if "inter frequency event identity" is set to 2a, 2b, 2c or 2e, otherwise the IE is not needed

10.3.7.20 Inter-frequency measurement system information

Information Element/Group name	Need	Multi	Type and reference	Semantics description
Inter-frequency measurement identity number	MD		Measurement identity number 10.3.7.73	The inter-frequency measurement identity number has default value 2.
Inter-frequency cell info list	OP		Inter-frequency cell info list 10.3.7.13	
Inter-frequency measurement quantity	OP		Inter-frequency measurement quantity 10.3.7.18	
Inter-frequency measurement reporting criteria	OP		Inter-frequency measurement reporting criteria 10.3.7.19	

10.3.7.21 Inter-frequency reporting quantity

Information Element/Group name	Need	Multi	Type and reference	Semantics description
UTRA Carrier RSSI	MP		Boolean	TRUE means report is requested
Frequency quality estimate	MP		Boolean	TRUE means that report is requested
Non frequency related cell reporting quantities	MP		Cell reporting quantities 10.3.7.5	

10.3.7.22 Inter-frequency SET UPDATE

NOTE: Only for FDD.

Contains the changes of the active set associated with a non-used frequency. This information makes it possible to use events defined for Intra-frequency measurement within the same non-used frequency for Inter-frequency measurement reporting criteria. This information also controls if the UE should use autonomous updating of the active set associated with a non-used frequency.

Information Element/group name	Need	Multi	Type and reference	Semantics description
UE autonomous update mode	MP		Enumerated (On, On with no reporting, Off)	
Non autonomous update mode	CV-Update			
>Radio link addition information	OP	1 to <maxRL>		Radio link addition information required for each RL to add
>>Primary CPICH info	MP		Primary CPICH info 10.3.6.59	Note 1
>Radio link removal information	OP	1 to <MaxRL>		Radio link removal information required for each RL to remove
>>Primary CPICH info	MP		Primary CPICH info 10.3.6.59	Note 1

Condition	Explanation
Update	The IE is mandatory if IE "UE autonomous update mode" is set to "Off", otherwise the IE is not needed.

NOTE 1: If it is assumed that CPICH downlink scrambling code is always allocated with sufficient reuse distances, CPICH downlink scrambling code will be enough for designating the different radio links.

10.3.7.23 Inter-system cell info list

Contains the measurement object information for an inter-system measurement.

Information Element/Group name	Need	Multi	Type and reference	Semantics description
Removed inter-system cells	OP	1 to <maxCellMeas>		
>Inter-system cell id	MP		Integer(0 .. <maxCellMeas> - 1)	
New inter-system cells	OP	1 to <maxCellMeas>		
>Inter-system cell id	MD		Integer(0 .. <maxCellMeas> - 1)	The first inter-system cell in the list corresponds to inter-system cell id 0, the second corresponds to inter-system cell id 1 etc.
>CHOICE Radio Access Technology	MP			At least one spare choice, Criticality: Reject, is needed.
>>GSM				
>>>Qoffsets,n	MD		Integer (-50..50)	Default value if the value of the previous Qoffsets,n in the list (NOTE: the first occurrence is then MP)
>>>HCS Neighbouring cell information	OP		HCS Neighbouring cell information 10.3.7.11	
>>>Qrxlevmin	MP			
>>>Maximum allowed UL TX power	MP		Maximum allowed UL TX power 10.3.6.38	
>>>BSIC	MP		BSIC 10.3.8.2	
>>>BCCH ARFCN	MP		Integer (0..1023)	GSM TS 04.18
>>>Output power	OP			
>>IS-2000				
>>>System specific measurement info			enumerated (frequency, timeslot, colour code, output power, PN offset)	For IS-2000, use fields from TIA/EIA/IS-2000.5, Section 3.7.3.3.2.27, Candidate Frequency NeighborNeighbour List Message

10.3.7.24 Inter-system event identity

Information Element/Group name	Need	Multi	Type and reference	Semantics description
Inter-system event identity	MP		Enumerated (3a, 3b, 3c, 3d)	

10.3.7.25 Inter-system info

Inter-system info defines the target system for redirected cell selection.

Information Element/Group name	Need	Multi	Type and reference	Semantics description
Inter-system info	MP		Enumerated (GSM)	At least 1 spare value, criticality = reject, required

10.3.7.26 Inter-system measured results list

Information Element/Group name	Need	Multi	Type and reference	Semantics description
Inter-system measurement results	OP	1 to <maxOther RAT>		
>CHOICE system				At least one spare value, criticality = reject, required
>>GSM				
>>>Frequency	MP			
>>>GSM carrier RSSI	OP		bit string(6)	RXLEV GSM TS 05.08
>>>Pathloss	OP		Integer(46..158)	In dB
>>>BSIC	OP		BSIC 10.3.8.2	
>>>Observed time difference to GSM cell	OP		Observed time difference to GSM cell 10.3.7.77	

10.3.7.27 Inter-system measurement

Information Element/Group name	Need	Multi	Type and reference	Semantics description
Inter-system cell info list	OP		Inter-system cell info list 10.3.7.23	Measurement object
Inter-system measurement quantity	OP		Inter-system measurement quantity 10.3.7.29	
Inter-system reporting quantity	OP		Inter-system reporting quantity 10.3.7.32	
Reporting cell status	CV-reporting		Reporting cell status 10.3.7.86	
CHOICE report criteria	MP			
>Inter-system measurement reporting criteria			Inter-system measurement reporting criteria 10.3.7.30	
>Periodical reporting criteria			Periodical reporting criteria 10.3.7.78	
>No reporting				(no data) Chosen when this measurement only is used as additional measurement to another measurement

Condition	Explanation
reporting	This IE is optional if the CHOICE "report criteria" is equal to "periodical reporting criteria" or "No reporting", otherwise the IE is not needed

10.3.7.28 Inter-system measurement event results

This IE contains the measurement event results that are reported to UTRAN for inter-system measurements.

Information Element/Group name	Need	Multi	Type and reference	Semantics description
Inter-system event identity	MP		Inter-system event identity 10.3.7.24	
Cells to report	MP	1 to <maxCellMeas>		
>Frequency	MP			
>BSIC	MP		BSIC 10.3.8.2	

10.3.7.29 Inter-system measurement quantity

The quantity the UE shall measure in case of inter-system measurement. It also includes the filtering of the measurements.

Information Element/Group name	Need	Multi	Type and reference	Semantics description
Measurement quantity for UTRAN quality estimate	MP		Intra-frequency measurement quantity 10.3.7.38	
CHOICE system	MP			
>GSM				
>>Measurement quantity	MP		Enumerated(GSM Carrier RSSI, Pathloss)	
>>Filter coefficient	MP		Filter coefficient 10.3.7.9	
>>BSIC verification required	MP		Enumerated(required, not required)	Note 1
>IS2000				
>>TADD Ec/I0	MP		Integer(0..63)	Admission criteria for neighbours, see subclause 2.6.6.2.6 of TIA/EIA/IS-2000.5
>>TCOMP Ec/I0	MP		Integer(0..15)	Admission criteria for neighbours, see subclause 2.6.6.2.5.2 of TIA/EIA/IS-2000.5
>>SOFT SLOPE	OP		Integer(0..63)	Admission criteria for neighbours, see subclause 2.6.6.2.3 and 2.6.6.2.5.2 of TIA/EIA/IS-2000.5
>>ADD_INTERCEPT	OP		Integer(0..63)	Admission criteria for neighbours, see subclause 2.6.6.2.5.2 of TIA/EIA/IS-2000.5

NOTE 1: The possibility to use this IE is dependant on comments from SMG2.

Also, this IE must be set to "required" if IE "Observed time difference to GSM cell" in IE "Inter-system reporting quantity" is set to "true".

10.3.7.30 Inter-system measurement reporting criteria

The triggering of the event-triggered reporting for an inter-system measurement. All events concerning inter-system measurements are labelled 3x where x is a,b,c..

Event 3a: The estimated quality of the currently used UTRAN frequency is below a certain threshold and the estimated quality of the other system is above a certain threshold.

Event 3b: The estimated quality of other system is below a certain threshold.

Event 3c: The estimated quality of other system is above a certain threshold.

Event 3d: Change of best cell in other system.

Information Element/Group name	Need	Multi	Type and reference	Semantics description
Parameters required for each event	OP	1 to <maxMeas Event>		
>Inter-system event identity	MP		Inter-system event identity 10.3.7.24	
>Threshold own system	CV – clause 0			
>W	CV – clause 0			In event 3a
>Threshold other system	CV – clause 1			In event 3a, 3b, 3c
>Hysteresis	MP			
>Time to trigger	MP		Time to trigger 10.3.7.89	Indicates the period of time between the timing of event detection and the timing of sending Measurement Report.
>Amount of reporting	MP			
>Reporting interval	MP			Indicates the interval of periodical reporting when such reporting is triggered by an event. A zero value indicates that event triggered periodical reporting shall not be applied.
>Reporting cell status	OP		Reporting cell status 10.3.7.86	

Condition	Explanation
Clause 0	The IE is mandatory if " Inter-system event identity" is set to "3a", otherwise the IE is not needed
Clause 1	The IE is mandatory if " Inter-system event identity" is set to 3a, 3b or 3c, otherwise the IE is not needed

10.3.7.31 Inter-system measurement system information

Information Element/Group name	Need	Multi	Type and reference	Semantics description
Inter-system measurement identity number	MD		Measurement identity number 10.3.7.73	The inter-system measurement identity number has default value 3.
Inter-system cell info list	OP		Inter-system cell info list 10.3.7.23	
Inter-system measurement quantity	OP		Inter-system measurement quantity 10.3.7.29	

10.3.7.32 Inter-system reporting quantity

For all boolean types TRUE means inclusion in the report is requested.

Information Element/Group name	Need	Multi	Type and reference	Semantics description
UTRAN estimated quality	MP		Boolean	
CHOICE system	MP			At least one spare choice, criticality = reject, required
>GSM				
>>Pathloss	MP		Boolean	
>>Observed time difference to GSM cell	MP		Boolean	
>>GSM Carrier RSSI	MP		Boolean	
>>BSIC	MP		Boolean	

10.3.7.33 Intra-frequency cell info list

Contains the measurement object information for an intra-frequency measurement.

Information Element/Group name	Need	Multi	Type and reference	Semantics description
Removed intra-frequency cells	OP	1 to <maxCellMeas>		
>Intra-frequency cell id	MP		Integer(0 .. <maxCellMeas> - 1)	
New intra-frequency cell	OP	1 to <maxCellMeas>		This information element must be present when "Intra-frequency cell info list" is included in the system information
>Intra-frequency cell id	MD		Integer(0 .. <maxCellMeas> - 1)	The first intra-frequency cell in the list corresponds to intra-frequency cell id 0, the second corresponds to intra-frequency cell id 1 etc.
>Cell info	MP		Cell info 10.3.7.2	

10.3.7.34 Intra-frequency event identity

Information Element/Group name	Need	Multi	Type and reference	Semantics description
Intra-frequency event identity	MP		Enumerated (1a,1b,1c,1d,1e,1f,1g,1h,1i)	

10.3.7.35 Intra-frequency measured results list

Information Element/Group name	Need	Multi	Type and reference	Semantics description
Intra-frequency measured results	OP	1 to <maxCellMeas>		
>Cell measured results	MP		Cell measured results 10.3.7.3	

10.3.7.36 Intra-frequency measurement

Information Element/Group name	Need	Multi	Type and reference	Semantics description
Intra-frequency cell info list	OP		Intra-frequency cell info list 10.3.7.33	Measurement object Not included for measurement of detected set.
Intra-frequency measurement quantity	OP		Intra-frequency measurement quantity 10.3.7.38	
Intra-frequency reporting quantity	OP		Intra-frequency reporting quantity 10.3.7.41	
Reporting cell status	CV-reporting		Reporting cell status 10.3.7.86	
Measurement validity	OP		Measurement validity 10.3.7.76	
CHOICE report criteria	MP			
>Intra-frequency measurement reporting criteria			Intra-frequency measurement reporting criteria 10.3.7.39	
>Periodical reporting criteria			Periodical reporting criteria 10.3.7.78	
>No reporting				(no data) Chosen when this measurement only is used as additional measurement to another measurement

Condition	Explanation
reporting	This IE is optional if the CHOICE "report criteria" is equal to "periodical reporting criteria" or "No reporting", otherwise the IE is not needed

10.3.7.37 Intra-frequency measurement event results

This IE contains the measurement event results that are reported to UTRAN for intra-frequency measurements.

Information Element/Group name	Need	Multi	Type and reference	Semantics description
Intra-frequency event identity	MP		Intra-frequency event identity 10.3.7.34	
Cell measured event results	MP		Cell measured event results 10.3.7.4	

10.3.7.38 Intra-frequency measurement quantity

The quantity the UE shall measure in case of intra-frequency measurement. It also includes the filtering of the measurements.

Information Element/Group name	Need	Multi	Type and reference	Semantics description
Filter coefficient	MP		Filter coefficient 10.3.7.9	
CHOICE mode	MP			
>FDD				
>>Measurement quantity	MP		Enumerated(C PICH Ec/N0, CPICH RSCP, Pathloss, UTRA Carrier RSSI)	Pathloss=Primary CPICH Tx power-CPICH RSCP If used in Inter system measurement quantity only Ec/N0 an RSCP is allowed. If used in inter-frequency measurement quantity RSSI is not allowed.
>TDD				
>>Measurement quantity list	MP	1 to 4		
>>>Measurement quantity	MP		Enumerated(Primary CCPCH RSCP, Pathloss, Timeslot ISCP, UTRA Carrier RSSI)	Pathloss=Primary CCPCH Tx power-Primary CCPCH RSCP If used in inter-frequency measurement quantity RSSI is not allowed.

10.3.7.39 Intra-frequency measurement reporting criteria

The triggering of the event-triggered reporting for an intra-frequency measurement. All events concerning intra-frequency measurements are labelled 1x where x is a, b, c....

Event 1a: A Primary CPICH enters the Reporting Range (FDD only).

Event 1b: A Primary CPICH leaves the Reporting Range (FDD only).

Event 1c: A Non-active Primary CPICH becomes better than an active Primary CPICH (FDD only).

Event 1d: Change of best cell [Note 1] (FDD only).

Event 1e: A Primary CPICH becomes better than an absolute threshold (FDD only).

Event 1f: A Primary CPICH becomes worse than an absolute threshold (FDD only).

Event 1g: Change of best cell in TDD.

Event 1h: Timeslot ISCP below a certain threshold (TDD only).

Event 1i: Timeslot ISCP above a certain threshold (TDD only).

Information Element/Group name	Need	Multi	Type and reference	Semantics description
Parameters required for each event	OP	1 to <maxMeasEvent>		
> Intra-frequency event identity	MP		Intra-frequency event identity 10.3.7.34	
>Triggering condition	CV – clause 0		Enumerated(Active set cells, Monitored set cells, Active set cells and monitored set cells)	Indicates which cells can trigger the event
>Reporting Range	CV – clause 2		Real(0..14.5 by step of 0.5)	In dB. In event 1a,1b.
>Cells forbidden to affect Reporting range	CV – clause 1	1 to <maxCellMeas>		In event 1a,1b
>>CHOICE mode	MP			
>>>FDD				
>>>>Primary CPICH info	MP		Primary CPICH info 10.3.6.59	
>>>TDD				
>>>>Primary CCPCH info	MP		Primary CCPCH info 10.3.6.56	
>W	CV – clause 2		Real(0.0..2.0 by step of 0.1)	
>Hysteresis	MP		Real(0..7.5 by step of 0.5)	In dB.
> Threshold used frequency	CV-clause 3		Integer (-115..165)	Range used depend on measurement quantity. CPICH RSCP -115 .. -40

Information Element/Group name	Need	Multi	Type and reference	Semantics description
				dBm CPICH Ec/No -24..0 dB Pathloss 30..165dB ISCP -115..-25 dBm
>Reporting deactivation threshold	CV – clause 4		Integer(0, 1, 2, 3, 4, 5, 6, 7)	In event 1a Indicates the maximum number of cells allowed in the active set in order for event 1a to occur. 0 means not applicable
>Replacement activation threshold	CV - clause 5		Integer(0, 1, 2, 3, 4, 5, 6, 7)	In event 1c Indicates the minimum number of cells allowed in the active set in order for event 1c to occur. 0 means not applicable
>Time to trigger	MP		Time to trigger 10.3.7.89	Indicates the period of time between the timing of event detection and the timing of sending Measurement Report. Time in ms
>Amount of reporting	MP		Integer(1, 2, 4, 8, 16, 32, 64, Infinity)	Measurement is "released" after the indicated amount of reporting from the UE itself.
>Reporting interval	MP		Integer(0, 250, 500, 1000, 2000, 4000, 8000, 16000)	Indicates the interval of periodical reporting when such reporting is triggered by an event. Interval in milliseconds. 0 means no periodical reporting
>Reporting cell status	OP		Reporting cell status 10.3.7.86	

Condition	Explanation
Clause 0	The IE is mandatory if "Intra-frequency event identity" is set to "1a","1b", "1e" or "1f", otherwise the IE is not needed
Clause 1	The IE is optional if "Intra-frequency event identity" is set to "1a" or "1b", otherwise the IE is not needed
Clause 2	The IE is mandatory if "Intra-frequency event identity" is set to "1a" or "1b", otherwise the IE is not needed
Clause 3	The IE is mandatory if "Intra-frequency event identity" is set to , "1e", "1f", "1h", "1i" or "1j", otherwise the IE is not needed
Clause 4	The IE is mandatory if "Intra-frequency event identity" is set to "1a", otherwise the IE is not needed
Clause 5	The IE is mandatory if "Intra-frequency event identity" is set to "1c", otherwise the IE is not needed
Clause 6	The IE is mandatory if "Intra-frequency event identity" is set to "1e" or "1f".

NOTE 1: When best PCCPCH in active set changes, all active cells are reported.

10.3.7.40 Intra-frequency measurement system information

Information Element/Group name	Need	Multi	Type and reference	Semantics description
Intra-frequency measurement identity number	MD		Measurement identity number 10.3.7.73	The intra-frequency measurement identity number has default value 1.
Intra-frequency cell info list	OP		Intra-frequency cell info list 10.3.7.33	
Intra-frequency measurement quantity	OP		Intra-frequency measurement quantity 10.3.7.38	
Intra-frequency reporting quantity for RACH Reporting	OP		Intra-frequency reporting quantity for RACH Reporting 10.3.7.42	
Maximum number of reported cells on RACH	OP		Maximum number of reported cells on RACH 10.3.7.68	
Reporting information for state CELL_DCH	OP		Reporting information for state CELL_DCH 10.3.7.87	Note 1

NOTE 1: The reporting of intra-frequency measurements is activated when state CELL_DCH is entered.

10.3.7.41 Intra-frequency reporting quantity

Contains the reporting quantity information for an intra-frequency measurement.

Information Element/Group name	Need	Multi	Type and reference	Semantics description
Reporting quantities for active set cells	MP		Cell reporting quantities 10.3.7.5	
Reporting quantities for monitored set cells	MP		Cell reporting quantities 10.3.7.5	
Reporting quantities for detected set cells	OP		Cell reporting quantities 10.3.7.5	

10.3.7.42 Intra-frequency reporting quantity for RACH reporting

Contains the reporting quantity information for an intra-frequency measurement report, which is sent on the RACH.

Information Element/Group name	Need	Multi	Type and reference	Semantics description
SFN-SFN observed time difference	MP		Enumerated(No report, type 1, type 2)	
CHOICE mode	MP			
>FDD				
>>Reporting quantity	MP		Enumerated(CPICH Ec/NO, CPICH RSCP, Pathloss, No report)	
>TDD				
>>Reporting quantity list	MP	1 to 2		
>>>Reporting quantity	MP		Enumerated(Timeslot ISCP, Primary CCPCH RSCP, No report)	

10.3.7.43 LCS Cipher GPS Data Indicator

The LCS Cipher GPS Data Indicator IE contains information for the ciphering of SIB types 15.1, 15.2 and 15.3.

Information Element/Group name	Need	Multi	Type and Reference	Semantics description
Ciphering parameters	OP			
>Ciphering Key Flag	MP		Bitstring(1)	See note 1
>Ciphering Serial Number	MP		Integer(0..65 535)	The serial number used in the DES ciphering algorithm

NOTE 1: The UE always receives two (2) cipher keys during the location update procedure. One of the keys is time-stamped to be current one and the other is time-stamped to be the next one. Thus, the UE always has two cipher keys in memory. The Cipher Key Change Indicator in this broadcast message instructs the UE whether to use current or next cipher key for deciphering the received broadcast message. The UE shall interpret this IE as follows:

- Ciphering Key Flag(previous message) = Ciphering Key Flag(this message) => Deciphering Key not changed
- Ciphering Key Flag(previous message) <> Ciphering Key Flag(this message) => Deciphering Key changed

10.3.7.44 LCS Error

Information Element/Group name	Need	Multi	Type and Reference	Semantics description
Error reason	MP		Enumerated(There were not enough cells to be received when performing mobile based OTDOA-IPDL. There were not enough GPS satellites to be received, when performing UE-based GPS location. Location calculation assistance data missing. Requested method not supported. Undefined error. Location request denied by the user. Location request not processed by the user and timeout.	
Additional Assistance Data	OP		structure and encoding as for the GPS Assistance Data IE in GSM 09.31 excluding the IEI and length octets	This field is optional. Its presence indicates that the target UE will retain assistance data already sent by the SRNC. The SRNC may send further assistance data for any new location attempt but need not resend previous assistance data. The field may contain the following: GPS Assistance Data necessary additional GPS assistance data

10.3.7.45 LCS GPS acquisition assistance

The Acquisition Assistance field of the GPS Assistance Data Information Element contains parameters that enable fast acquisition of the GPS signals in network-based GPS positioning. Essentially, these parameters describe the range and derivatives from respective satellites to the Reference Location at the Reference Time.

Information Element/Group name	Need	Multi	Type and Reference	Semantics description
CHOICE Reference Time				
>UTRAN reference time				GPS Time of Week counted in microseconds, given as GPS TOW in milliseconds and GPS TOW remainder in microseconds, UTRAN reference time = 1000 * GPS TOW msec + GPS TOW rem usec
>>GPS TOW msec	MP		Integer(0..6.048*108-1)	GPS Time of Week in milliseconds (rounded down to the nearest millisecond unit)
>>GPS TOW rem usec	MP		Integer(0..999)	GPS Time of Week in microseconds MOD 1000.
>>SFN	MP		Integer(0..4095)	
>GPS reference time only				
>>GPS TOW	MP		Integer(0..6.048*108-1)	GPS Time of Week in milliseconds (rounded down to the nearest millisecond unit).
Satellite information	MP	1 to <maxSat>		
>SatID	MP		Enumerated(0..63)	Identifies the satellites
>Doppler (0th order term)	MP		Integer(-2048..2047)	Hz, scaling factor 2.5
>Extra Doppler	OP			
>>Doppler (1st order term)	MP		Integer(-42..21)	Scaling factor 1/42
>>Doppler Uncertainty	MP		Real(12.5,25,50,100,200)	Hz
>Code Phase	MP		Integer(0..1022)	Chips, specifies the centre of the search window
>Integer Code Phase	MP		Integer(0..1023)	1023 chip segments
>GPS Bit number	MP		Integer(0..3)	Specifies GPS bit number (20 1023 chip segments)
>Code Phase Search Window	MP		Integer(1023,1,2,3,4,6,8,12,16,24,32,48,64,96,128,192)	Specifies the width of the search window.
>Azimuth and Elevation	OP			
>>Azimuth	MP		Integer(0..31)	Degrees, scale factor 11.25
>>Elevation	MP		Integer(0..7)	Degrees, scale factor 11.25

CHOICE Reference time	Condition under which the given reference time is chosen
UTRAN reference time	The reference time is relating GPS time to UTRAN time (SFN)
GPS reference time only	The time gives the time for which the location estimate is valid

10.3.7.46 LCS GPS almanac

These fields specify the coarse, long-term model of the satellite positions and clocks. With one exception (δ_i), these parameters are a subset of the ephemeris and clock correction parameters in the Navigation Model, although with reduced resolution and accuracy. The almanac model is useful for receiver tasks that require coarse accuracy, such as determining satellite visibility. The model is valid for up to one year, typically. Since it is a long-term model, the field should be provided for all satellites in the GPS constellation.

Information Element/Group name	Need	Multi	Type and Reference	Semantics description
WNa	MP		Bit string(8)	
Satellite information	MP	1 to <maxSat>		
>SatID	MP		Enumerated(0..63)	Satellite ID
>e	MP		Bit string(16)	
>toa	MP		Bit string(8)	
> δ i	MP		Bit string(16)	
>OMEGADOT	MP		Bit string(16)	
>SV Health	MP		Bit string(8)	
>A1/2	MP		Bit string(24)	
>OMEGA0	MP		Bit string(24)	
>M0	MP		Bit string(24)	
> ω	MP		Bit string(24)	
>af0	MP		Bit string(11)	
>af1	MP		Bit string(11)	

10.3.7.47 LCS GPS assistance data

The GPS Assistance Data element contains a single GPS assistance message that supports both UE-assisted and UE-based GPS methods. An Integrity Monitor (IM) shall detect unhealthy (e.g., failed/failing) satellites and also shall inform users of measurement quality in DGPS modes when satellites are healthy. Excessively large pseudo range errors, as evidenced by the magnitude of the corresponding DGPS correction, shall be used to detect failed satellites.

Unhealthy satellites should be detected within 10 seconds of the occurrence of the satellite failure. When unhealthy (e.g., failed/failing) satellites are detected, the assistance and/or DGPS correction data shall not be supplied for these satellites. When the error in the IM computed position is excessive for solutions based upon healthy satellites only, DGPS users shall be informed of measurement quality through the supplied UDRE values.

NOTE: Certain types of GPS Assistance data may be derived, wholly or partially, from other types of GPS Assistance data.

Information Element/Group name	Need	Multi	Type and Reference	Semantics description
LCS GPS reference time	OP		LCS GPS reference time 10.3.7.53	
LCS GPS reference location	OP		Ellipsoid point with altitude defined in 23.032	The Reference Location field contains a 3-D location without uncertainty specified as per 23.032. The purpose of this field is to provide the UE with a priori knowledge of its location in order to improve GPS receiver performance.
LCS GPS DGPS corrections	OP		LCS GPS DGPS corrections 10.3.7.48	
LCS GPS navigation model	OP		LCS GPS navigation model 10.3.7.51	
LCS GPS ionospheric model	OP		LCS GPS ionospheric model 10.3.7.49	
LCS GPS UTC model	OP		LCS GPS UTC model 10.3.7.54	
LCS GPS almanac	OP		LCS GPS almanac 10.3.7.46	
LCS GPS acquisition assistance	OP		LCS GPS acquisition assistance 10.3.7.45	
LCS GPS real-time integrity	OP		LCS GPS real-time integrity 10.3.7.52	

10.3.7.48 LCS GPS DGPS corrections

These fields specify the DGPS corrections to be used by the UE.

Information Element/Group name	Need	Multi	Type and Reference	Semantics description
GPS TOW	MP		Integer(0..604799)	Seconds. This field indicates the baseline time for which the corrections are valid.
Status/Health	MP		Enumerated(UDRE scale 1.0, UDRE scale 0.75, UDRE scale 0.5, UDRE scale 0.3, UDRE scale 0.2, UDRE scale 0.1, no data, invalid data)	This field indicates the status of the differential corrections
Satellite information	MP	1 to <maxSat>		
>SatID	MP		Enumerated(0..63)	Satellite ID
>IODE	MP		Bit string(8)	This IE is the sequence number for the ephemeris for the particular satellite. The UE can use this IE to determine if new ephemeris is used for calculating the corrections that are provided in the broadcast message. This eight-bit IE is incremented for each new set of ephemeris for the satellite and may occupy the numerical range of [0, 239] during normal operations. See [13] for details
>UDRE	MP		Enumerated(UDRE \leq 1.0 m, 1.0m < UDRE \leq 4.0m, 4.0m < UDRE \leq 8.0m, 8.0m < UDRE)	User Differential Range Error. This field provides an estimate of the uncertainty (1- σ) in the corrections for the particular satellite. The value in this field shall be multiplied by the UDRE Scale Factor in the common Corrections Status/Health field to determine the final UDRE estimate for the particular satellite. See [13] for details
>PRC	MP		Integer(-2047..2047)	Scaling factor 0.32 meters See (different from [13])
>RRC	MP		Integer(-127.. 127)	Scaling factor 0.032 meters/sec (different from [13])
>Delta PRC2	MP		Integer(-127..127)	Meters. The difference in the pseudorange correction between the satellite's ephemeris identified by IODE and the previous ephemeris two issues ago IODE -2.
>Delta RRC2	MP		Integer(-7..7)	Scaling factor 0.032 meters/sec. The difference in the rate of the change of the pseudorange correction between the satellite's ephemeris identified by IODE and the previous ephemeris two issues ago IODE -2.

>Delta PRC3	MP		Integer(-127..127)	Meters. The difference in the pseudorange correction between the satellite's ephemeris identified by IODE and the previous ephemeris three issues ago IODE -3.
>Delta RRC3	MP		Integer(-7..7)	Scaling factor 0.032 meters/sec. The difference in the rate of the change of the pseudorange correction between the satellite's ephemeris identified by IODE and the previous ephemeris three issues ago IODE -3.

NOTE: Each UDRE value shall be adjusted based on the operation of an Integrity Monitor (IM) function which exists at the network (SRNC, GPS server, or reference GPS receiver itself). Positioning errors derived at the IM which are excessive relative to DGPS expected accuracy levels shall be used to scale the UDRE values to produce consistency.

10.3.7.49 LCS GPS ionospheric model

The Ionospheric Model contains fields needed to model the propagation delays of the GPS signals through the ionosphere. Proper use of these fields allows a single-frequency GPS receiver to remove approximately 50% of the ionospheric delay from the range measurements. The Ionospheric Model is valid for the entire constellation and changes slowly relative to the Navigation Model.

Information Element/Group name	Need	Multi	Type and Reference	Semantics description
α_0	MP		Bit string(8)	
α_1	MP		Bit string(8)	
α_2	MP		Bit string(8)	
α_3	MP		Bit string(8)	
β_0	MP		Bit string(8)	
β_1	MP		Bit string(8)	
β_2	MP		Bit string(8)	
β_3	MP		Bit string(8)	

10.3.7.50 LCS GPS measurement

The purpose of the GPS Measurement Information element is to provide GPS measurement information from the UE to the SRNC. This information includes the measurements of code phase and Doppler, which enables the network-based GPS method where the position is computed in the SRNC.

Information Element/Group name	Need	Multi	Type and Reference	Semantics description
Reference SFN	OP		Integer(0..4095)	The SFN for which the location is valid
GPS TOW msec	MP		Integer(0..6.048*10 ⁸ -1)	GPS Time of Week in milliseconds (rounded down to the nearest millisecond unit). This time is the GPS TOW measured by the UE. If the Reference SFN field is present it is the ms flank closest to the beginning of that frame. GPS Time of Week in microseconds = 1000 * GPS TOW msec + GPS TOW rem usec
GPS TOW rem usec	CV-capability and request		Integer(0..999)	GPS Time of Week in microseconds MOD 1000.
Measurement Parameters	MP	1 to <maxSat>		
>Satellite ID	MP		Enumerated(0..63)	
>C/No	MP		Integer(0..63)	the estimate of the carrier-to-noise ratio of the received signal from the particular satellite used in the measurement. It is given in whole dBs. Typical levels observed by UE-based GPS units will be in the range of 20 – 50 dB.
>Doppler	MP		Integer(-32768..32768)	Hz, scale factor 0.2.
>Whole GPS Chips	MP		Integer(0..1023)	Unit in GPS chips
>Fractional GPS Chips	MP		Integer(0..(2 ¹⁰ -1))	Scale factor 2-10
>Multipath Indicator	MP		Enumerated(NM, low, medium, high)	See note 1
>Pseudorange RMS Error	MP		Enumerated(range index 0..range index 63)	See note 2

Condition	Explanation
Capability and request	This field is included only if the UE has this capability and if it was requested in the LCS reporting quantity

NOTE 1: The following table gives the mapping of the multipath indicator field.

Value	Multipath Indication
NM	Not measured
Low	MP error < 5m
Medium	5m < MP error < 43m
High	MP error > 43m

NOTE 2: The following table gives the bitmapping of the Pseudorange RMS Error field.

Range Index	Mantissa	Exponent	Floating-Point value, xi	Pseudorange value, P
0	000	000	0.5	$P < 0.5$
1	001	000	0.5625	$0.5 \leq P < 0.5625$
I	X	Y	$0.5 * (1 + x/8) * 2^y$	$x_{i-1} \leq P < x_i$
62	110	111	112	$104 \leq P < 112$
63	111	111	--	$112 \leq P$

10.3.7.51 LCS GPS navigation model

This IE contain information required to manage the transfer of precise navigation data to the GPS-capable UE. This information includes control bit fields as well as satellite ephemeris and clock corrections.

Information Element/Group name	Need	Multi	Type and Reference	Semantics description
N_SAT	MP		Integer(1..16)	The number of satellites included in this IE
Satellite information	MP	1 to <maxSat>		
>SatID	MP		Enumerated(0..63)	Satellite ID
>Satellite Status	MP		Enumerated(NS_NN, ES_SN, ES_NN, REVD)	See note 1
>C/A or P on L2	MP		Bit string(2)	Standard formats as defined in [12]
>URA Index	MP		Bit string(4)	
>SV Health	MP		Bit string(6)	
>IODC	MP		Bit string(10(1))	
>L2 P Data Flag	MP		Bit string(1)	
>SF 1 Reserved	MP		Bit string(87)	
>TGD	MP		Bit string(8)	
>toc	MP		Bit string(16(1))	
>af2	MP		Bit string(8)	
>af1	MP		Bit string(16)	
>af0	MP		Bit string(22)	
>Crs	MP		Bit string(16)	
> Δn	MP		Bit string(16)	
>M0	MP		Bit string(32)	
>Cuc	MP		Bit string(16)	
>e	MP		Bit string(32(1))	
>Cus	MP		Bit string(16)	
>(A)1/2	MP		Bit string(32(1))	
>toe	MP		Bit string(16(1))	
>Fit Interval Flag	MP		Bit string(1)	
>AODO	MP		Bit string(5)	
>Cic	MP		Bit string(16)	
>OMEGA0	MP		Bit string(32)	
>Cis	MP		Bit string(16)	
>i0	MP		Bit string(32)	
>Crc	MP		Bit string(16)	
> ω	MP		Bit string(32)	
>OMEGAdot	MP		Bit string(24)	
>ldot	MP		Bit string(14)	

NOTE 1: The UE shall interpret enumerated symbols as follows.

Symbol	Interpretation
NS_NN	New satellite, new Navigation Model
ES_SN	Existing satellite, same Navigation Model
ES_NN	Existing satellite, new Navigation Model
REVD	Reserved

Condition	Explanation
status	Group Included unless status is ES_SN

10.3.7.52 LCS GPS real-time integrity

Contains parameters that describe the real-time status of the GPS constellation. Primarily intended for non-differential applications, the real-time integrity of the satellite constellation is of importance as there is no differential correction data by which the mobile can determine the soundness of each satellite signal. The Real-Time GPS Satellite Integrity data communicates the health of the constellation to the mobile in real-time. The satellites identified in this IE should not be used for position fixes at the moment.

Information Element/Group name	Need	Multi	Type and Reference	Semantics description
Satellite information	OP	1 to <maxSat >		N_BAD_SAT=the number of bad satellites included in this IE
>BadSatID	MP		Enumerated(0..63)	Satellite ID

10.3.7.53 LCS GPS reference time

Information Element/Group name	Need	Multi	Type and Reference	Semantics description
GPS Week	MP		Integer(0..1023)	
GPS TOW msec	MP		Integer(0..6.048*10 ⁸ -1)	GPS Time of Week in milliseconds (rounded down to the nearest millisecond unit). GPS Time of Week in microseconds = 1000 * GPS TOW msec + GPS TOW rem usec
GPS TOW rem usec	MP		Integer(0..999)	GPS Time of Week in microseconds MOD 1000.
SFN	MP		Integer(0..4095)	The SFN which the GPS TOW time stamps
GPS TOW Assist	OP	1 to <maxSat >		Fields to help the UE with time-recovery (needed to predict satellite signal)
>SatID	MP		Enumerated(0..63)	Identifies the satellite for which the corrections are applicable
>TLM Message	MP		Bit string(14)	A 14-bit value representing the Telemetry Message (TLM) being broadcast by the GPS satellite identified by the particular SatID, with the MSB occurring first in the satellite transmission.
>Anti-Spoof	MP		Boolean	The Anti-Spoof and Alert flags that are being broadcast by the GPS satellite identified by SatID.
>Alert	MP		Boolean	
>TLM Reserved	MP		Bit string(2)	Two reserved bits in the TLM Word being broadcast by the GPS satellite identified by SatID, with the MSB occurring first in the satellite transmission.

10.3.7.54 LCS GPS UTC model

The UTC Model field contains a set of parameters needed to relate GPS time to Universal Time Coordinate (UTC).

Information Element/Group name	Need	Multi	Type and Reference	Semantics description
A1	MP		Bit string(24)	
A0	MP		Bit string(32)	
tot	MP		Bit string(8)	
ΔtLS	MP		Bit string(8)	
WNt	MP		Bit string(8)	
WNLSF	MP		Bit string(8)	
DN	MP		Bit string(8)	
$\Delta tLSF$	MP		Bit string(8)	

10.3.7.55 LCS IPDL parameters

Information Element/Group name	Need	Multi	Type and Reference	Semantics description
IP spacing	MP		Integer(5,7,10,15,20,30,40,50)	The IPs are repeated every IP spacing frame.
IP length	MP		Integer(5,10)	The length in symbols of the idle periods
IP offset	MP		Integer(0..9)	Relates the BFN and SFN, should be same as T _{cell} defined in 25.402
Seed	MP		Integer(0..63)	Seed used to start the random number generator
Burst mode parameters	OP			
>Burst Start	MP		Integer(0..15)	The frame number where the 1st Idle Period Burst occurs within an SFN cycle. Scaling factor 256.
>Burst Length	MP		Integer(10..25)	Number of Idle Periods in a 'burst' of Idle Periods
>Burst freq	MP		Integer(1..16)	Number of 10ms frames between consecutive Idle Period bursts. Scaling factor 256.

The function IP_{position}(x) described below yields the position of the xth Idle Period relative to a) the start of the SFN cycle when continuous mode or b) the start of a burst when in burst mode. The operator "%" denotes the modulo operator. Regardless of mode of operation, the Idle Period pattern is reset at the start of every SFN cycle. Continuous mode can be considered as a specific case of the burst mode with just one burst spanning the whole SFN cycle. Note also that x will be reset to x=1 for the first idle period in a SFN cycle for both continuous and burst modes and will also, in the case of burst mode, be reset for the first Idle Period in every burst.

Max_{dev}=150-IP length

rand(x)= (106.rand(x-1) + 1283)mod6075,

rand(0)=seed

IP_{position}(x) = x*IP_{spacing}*150 + rand(xmod64)modMax_{dev}+IP_{offset}

10.3.7.56 LCS measured results

Information Element/Group name	Need	Multi	Type and reference	Semantics description
LCS Multiple Sets	OP		LCS Multiple Sets 10.3.7.59	
LCS reference cell Identity	OP		Primary CPICH Info 10.3.6.59	
LCS OTDOA measurement	OP		LCS OTDOA measurement 10.3.7.62	
LCS Position	OP		LCS Position 10.3.7.65	
LCS GPS measurement	OP		LCS GPS measurement 10.3.7.50	
LCS error	OP		LCS error 10.3.7.44	Included if LCS error occurred

10.3.7.57 LCS measurement

Information Element/Group name	Need	Multi	Type and reference	Semantics description
LCS reporting quantity	MP		LCS reporting quantity 10.3.7.67	
CHOICE reporting criteria	MP			
>LCS reporting criteria			LCS reporting criteria 10.3.7.66	
>Periodical reporting criteria			Periodical reporting criteria 10.3.7.78	
>No reporting				(no data) Chosen when this measurement only is used as additional measurement to another measurement
LCS OTDOA assistance data	OP		LCS OTDOA assistance data 10.3.7.60	
LCS GPS assistance data	OP		LCS GPS assistance data 10.3.7.47	

10.3.7.58 LCS measurement event results

This IE contains the measurement event results that are reported to UTRAN for LCS measurements.

Information Element/Group name	Need	Multi	Type and Reference	Semantics description
CHOICE Event ID	MP			
>7a				
>>LCS Position	MP		LCS Position 10.3.7.65	
>7b				
>> LCS OTDOA measurement	MP		LCS OTDOA measureme nt 10.3.7.62	
>7c				
>> LCS GPS measurement	MP		LCS GPS measureme nt 10.3.7.50	

10.3.7.59 LCS multiple sets

This element indicates how many OTDOA Measurement Information sets or GPS Measurement Information sets, and Reference cells are included in this element. This element is optional. If this element is absent, a single measurement set is included.

Information Element/Group name	Need	Multi	Type and Reference	Semantics description
Number of OTDOA-IPDL/GPS Measurement Information Sets	MP		Integer(2..3)	
Number of Reference Cells	MP		Integer(1..3)	
Reference Cell relation to Measurement Elements	OP		Enumerated(First reference cell is related to first and second OTDOA-IPDL/GPS Measurement Information Sets, and second reference cell is related to third OTDOA-IPDL/GPS Measurement Information Sets. First reference cell is related to first and third OTDOA-IPDL/GPS Measurement Information Sets, and second reference cell is related to second OTDOA-IPDL/GPS Measurement Information Sets. First reference cell is related to first OTDOA-IPDL/GPS Measurement Information Sets, and second reference cell is related to second and third OTDOA/GPS Measurement Information Sets.)	This field indicates how the reference cells listed in this element relate to measurement sets later in this component. This field is conditional and included only if Number of OTDOA-IPDL/GPS Measurement Information Sets is '3' and Number of Reference cells is '2'. If this field is not included, the relation between reference cell and Number of OTDOA-IPDL/GPS Measurement Information Sets is as follows: If there are three sets and three reference cells -> First reference cell relates to first set, second reference cell relates to second set, and third reference cell relates to third set. If there are two sets and two reference cells -> First reference cell relates to first set, and second reference cell relates to second set. If there is only one reference cell and 1-3 sets -> this reference cell relates to all sets.

10.3.7.60 LCS OTDOA assistance data

Information Element/Group name	Need	Multi	Type and Reference	Semantics description
LCS OTDOA reference cell for assistance data	OP		LCS OTDOA reference cell for assistance data 10.3.7.64	
LCS OTDOA measurement assistance data	OP	1 to <maxCellMeasurements>	LCS OTDOA measurement assistance data 10.3.7.63	
LCS IPDL parameters	OP		LCS IPDL parameters 10.3.7.55	If this element is not included there are no idle periods present

10.3.7.61 LCS OTDOA assistance for SIB

Information Element/Group name	Need	Multi	Type and Reference	Semantics description
Ciphering parameters	OP			Determines if DGPS correction fields are ciphered
>Ciphering Key Flag	MP		Bitstring(1)	See note 1
>Ciphering Serial Number	MP		Integer(0..65535)	The serial number used in the DES ciphering algorithm
Search Window Size	MP		Integer(10, 20, 30, 40, 50, 60, 70, infinity)	Specifies the maximum size of the search window in chips. Infinity means more
Reference Cell Position	MP		Ellipsoid point or Ellipsoid point with altitude as defined in 23.032	The position of the antenna which defines the serving cell. Used for the UE based method.
LCS IPDL parameters	OP		LCS IPDL parameters 10.3.7.55	If this element is not included there are no idle periods present
Cells to measure on	MP	1 to <maxCellMeas>		
>SFN-SFN drift	OP		Real(0,+0.33,+0.66,+1,+1.33,+1.66,+2,+2.5,+3,+4,+5,+7,+9,+11,+13,+15,-0.33,-0.66,-1,-1.33,-1.66,-2,-2.5,-3,-4,-5,-7,-9,-11,-13,-15)	The SFN-SFN drift value indicate the relative time drift in meters per second. Positive and negative values can be indicated as well as no drift value.
>Primary CPICH info	MP		Primary CPICH info 10.3.6.59	
>Frequency info	OP		Frequency info 10.3.6.35	Default the same. Included if different
>SFN-SFN observed time difference	MP		SFN-SFN observed time difference type 1. 10.3.7.88	Gives the relative timing compared to the reference cell
>Fine SFN-SFN	MP		Real(0,0.25,0.5,0.75)	Gives finer resolution for UE-Based In chips
>Cell Position	MD			Default = Same as previous cell
>>Relative North	MP		Integer(-32767..32767)	Seconds, scale factor 0.03. Relative position compared to ref. cell.
>>Relative East	MP		Integer(-32767..32767)	Seconds, scale factor 0.03. Relative position compared to ref. cell.
>>Relative Altitude	MP		Integer(-4095..4095)	Relative altitude in meters compared to ref. cell.

NOTE 1: The UE always receives two (2) cipher keys during the location update procedure. One of the keys is time-stamped to be current one and the other is time-stamped to be the next one. Thus, the UE always has two cipher keys in memory. The Cipher Key Change Indicator in this broadcast message instructs the UE whether to use current or next cipher key for deciphering the received broadcast message. The UE shall interpret this IE as follows:

- Ciphering Key Flag(previous message) = Ciphering Key Flag(this message) => Deciphering Key not changed
- Ciphering Key Flag(previous message) <> Ciphering Key Flag(this message) => Deciphering Key changed

10.3.7.62 LCS OTDOA measurement

The purpose of the OTDOA Measurement Information element is to provide OTDOA measurements of signals sent from the reference and neighbour cells.

Information Element/Group name	Need	Multi	Type and Reference	Semantics description
SFN	MP		Integer(0..4095)	SFN during which the last measurement was performed
UE Rx-Tx time difference	MP		Real(876..1172 by step of 0.25)	The UE Rx-Tx timing can be used to determine the propagation delay in chips
Quality type	OP		Enumerated(STD_10,STD_50,CPICH Ec/N0)	Type of quality in the quality field, default=DEFAULT_QUALITY
CHOICE Quality type	MP			
>STD_10				
>>Reference Quality 10	MP		Integer(10..320 by step of 10)	Std of TOA measurements from the cell
>STD_50				
>>Reference Quality 50	MP		Integer(50..1600 by step of 50)	Std of TOA measurements from the cell
>CPICH Ec/N0				
>>CPICH Ec/N0	MP		Enumerated(<-24, -24 dB ≤ CPICH Ec/No < -23 dB,.. -1 dB ≤ CPICH Ec/No < -0 dB, >=0 dB)	CPICH Ec/N0 for the measurement
>DEFAULT_QUALITY				
>>Reference Quality	MP		Enumerated(0-19 meters, 20-39 meters, 40-79 meters, 80-159 meters, 160-319 meters, 320-639 meters, 640-1319 meters over 1320 meters)	Estimated error in meters.
NeighborNeighbours	MP	0..maxCell Meas		Number of neighborneighbours included in this IE
>NeighborNeighbour Identity	OP		Primary CPICH info 10.3.6.59	If this field is left out it the identity is the same as in the first set of multiple sets.
>NeighborNeighbour Quality	MP		Bit string(depends on Quality type)	Quality of the OTDOA from the neighborneighbour cell.
>SFN-SFN observed time difference	MP		SFN-SFN observed time difference 10.3.7.88	Gives the timing relative to the reference cell. Only type 2 is allowed. Type 2 means that only the slot timing is accounted for

CHOICE Quality type	Condition under which the given quality type is chosen
STD_10	Chosen when the quality type is standard deviation with a step-size of 10 m
STD_50	Chosen when the quality type is standard deviation with a step-size of 50 m
CPICH Ec/N0	Chosen when the quality type is CPICH Ec/N0
Default	Chosen if the quality type field is not included.

10.3.7.63 LCS OTDOA measurement assistance data

This IE gives approximate cell timing in order to decrease the search window.

Information Element/Group name	Need	Multi	Type and Reference	Semantics description
Primary CPICH info	MP		Primary CPICH info 10.3.6.59	
Frequency info	OP		Frequency info 10.3.6.35	Default the same. Included if different
SFN-SFN observed time difference	MP		SFN-SFN observed time difference type 1. 10.3.7.88	Gives the relative timing compared to the reference cell
Fine SFN-SFN	OP		Real(0,0.25, 0.5,0.75)	Gives finer resolution for UE-Based
Search Window Size	MP		Integer(10, 20, 30, 40, 50, 60,70, infinity)	Specifies the maximum size of the search window in chips. Infinity means more
Relative North	OP		Integer(-20000..20000)	Seconds, scale factor 0.03. Relative position compared to ref. cell.
Relative East	OP		Integer(-20000..20000)	Seconds, scale factor 0.03. Relative position compared to ref. cell.
Relative Altitude	OP		Integer(-4000..4000)	Relative altitude in meters compared to ref. cell.

10.3.7.64 LCS OTDOA reference cell for assistance data

This IE defines the cell used for time references in all OTDOA measurements.

Information Element/Group name	Need	Multi	Type and Reference	Semantics description
Primary CPICH info	MP		Primary CPICH info 10.3.6.59	
Frequency info	OP		Frequency info 10.3.6.35	Default the same. Included if different
Cell Position	OP		Ellipsoid point or Ellipsoid point with altitude as defined in 23.032	The position of the antenna which defines the cell. Can be used for the UE based method.

10.3.7.65 LCS position

The purpose of Location Information element is to provide the location estimate from the UE to the network, if the UE is capable of determining its own position.

Information Element/Group name	Need	Multi	Type and Reference	Semantics description
Reference SFN	MP		Integer(0..4095)	The SFN for which the location is valid
GPS TOW msec	CV-Capability and request		Integer(0..6.048*108-1)	GPS Time of Week in milliseconds (rounded down to the nearest millisecond unit). This time-stamps the beginning of the frame defined in Reference SFN GPS Time of Week in microseconds = 1000 * GPS TOW msec + GPS TOW rem usec
GPS TOW rem usec	CV-Capability and request		Integer(0..999)	GPS Time of Week in microseconds MOD 1000.
Position estimate	MP		23.032, allowed types are Ellipsoid Point; Ellipsoid point with uncertainty circle; Ellipsoid point with uncertainty ellipse; Ellipsoid point with altitude; Ellipsoid point with altitude and uncertainty ellipse.	

Condition	Explanation
Capability and request	This field is included only if the UE has this capability and if it was requested in the LCS reporting quantity and if the method was UE-based GPS

10.3.7.66 LCS reporting criteria

The triggering of the event-triggered reporting for an LCS measurement. There are three types of events. The first, 7a, is for UE-based methods and is triggered when the position has changed more than a threshold. The second one, 7b, is primarily for UE assisted methods, but can be used also for UE based. It is triggered when the SFN-SFN measurement has changed more than a certain threshold. The third one, 7c, is triggered when the GPS time and the SFN time has drifted apart more than a certain threshold.

Information Element/Group name	Need	Multi	Type and Reference	Semantics description
Parameters required for each event	OP	1 to <maxMeas Event>		
>Event ID	MP		Enumerated (7a,7b,7c)	7a=Position change 7b=SFN-SFN change, 7c=SFN-GPS TOW change
>Amount of reporting	MP		Integer(1, 2, 4, 8, 16, 32, 64,infinite)	
>Report first fix	MP		Boolean	If true the UE reports the position once the measurement control is received, and then each time an event is triggered.
>Measurement interval	MP		Integer(5,15, 60,300,900,1 800,3600,72 00)	Indicates how often the UE should make the measurement In seconds
>CHOICE Event ID				
>>7a				
>>>Threshold Position Change	MP		Integer(10,2 0,30,40,50,1 00,200,300,5 00,1000,200 0,5000,1000 0,20000,500 00,100000)	Indicated how much the position should change compared to last reported position fix in order to trigger the event.
>>7b				
>>>Threshold SFN-SFN change	MP		Real(0.25,0. 5,1,2,3,4,5,1 0,20,50,100, 200,500,100 0,2000,5000)	Chips. Indicates how much the SFN-SFN measurement of ANY measured cell is allowed to change before the event is triggered.
>>7c				
>>>Threshold SFN-GPS TOW	MP		Integer(1,2,3 ,5,10,20,50,1 00)	Time in ms. When the GPS TOW and SFN timer has drifted apart more than the specified value the event is triggered)

10.3.7.67 LCS reporting quantity

The purpose of the element is to express the allowed/required location method(s), and to provide information required QoS.

Information Element/Group name	Need	Multi	Type and Reference	Semantics description
Method Type	MP		Enumerated(UE assisted, UE based, UE based is preferred but UE assisted is allowed, UE assisted is preferred but UE based is allowed)	
Positioning Methods	MP		Enumerated(OTDOA, GPS OTDOA or GPS)	Indicates which location method or methods should be used. The third option means that both can be reported. OTDOA includes IPDL if idle periods are present.
Response Time	MP		Integer(1,2,4, 8, 16, 32, 64, 128)	Indicates the desired response time in seconds
Accuracy	CV		Bit string(7)	Mandatory in all cases except when Method Type is UE assisted, then it is optional. 23.032
GPS timing of Cell wanted	MP		Boolean	If true the SRNC wants the UE to report the SFN-GPS timing of the reference cell. This is however optional in the UE.
Multiple Sets	MP		Boolean	This field indicates whether UE is requested to send multiple OTDOA/GPS Measurement Information Sets. The maximum number of measurement sets is three. This is field is mandatory. UE is expected to include the current measurement set.
Environment Characterization	OP		Enumerated(possibly heavy multipath and NLOS conditions, no or light multipath and usually LOS conditions, not defined or mixed environment)	The first category correspond to e.g. Urban or Bad Urban channels. The second category corresponds to Rural or Suburban channels

10.3.7.68 Maximum number of reported cells on RACH

Information Element/Group name	Need	Multi	Type and reference	Semantics description
Maximum number of reported cells	MP		Enumerated (no report, current cell, current cell + best neighbour, current cell+2 best neighbours, ..., current cell+6 best neighbours)	

10.3.7.69 Measured results

Contains the measured results of the quantity indicated optionally by Reporting Quantity in Measurement Control. "Measured results" can be used for both event trigger mode and periodical reporting mode. The list should be in the order of the value of the measurement quality (the first cell should be the best cell). The "best" FDD cell has the largest value when the measurement quantity is "Ec/No" or "RSCP". On the other hand, the "best" cell has the smallest value when the measurement quantity is "Pathloss". The "best" TDD cell has the largest value when measurement quantity is "Primary CCPCH RSCP".

Information Element/Group name	Need	Multi	Type and reference	Semantics description
CHOICE Measurement	MP			
>Intra-frequency measured results list			Intra-frequency measured results list 10.3.7.35	
>Inter-frequency measured results list			Inter-frequency measured results list 10.3.7.15	
>Inter-system measured results list			Inter-system measured results list 10.3.7.26	
>Traffic volume measured results list			Traffic volume measured results list 10.3.7.92	
>Quality measured results list			Quality measured results list 10.3.7.80	
>UE Internal measured results			UE Internal measured results 10.3.7.101	
>LCS measured results			LCS measured results 10.3.7.56	

10.3.7.70 Measured results on RACH

Contains the measured results on RACH of the quantity indicated optionally by Reporting Quantity in the system information broadcast on BCH. The list should be in the order of the value of the measurement quality (the first cell should be the best cell). The "best" FDD cell has the largest value when the measurement quantity is "Ec/No" or "RSCP". On the other hand, the "best" cell has the smallest value when the measurement quantity is "Pathloss". The "best" TDD cell has the largest value when measurement quantity is "Primary CCPCH RSCP".

Information Element/group name	Need	Multi	Type and reference	Semantics description
Measurement result for current cell				
CHOICE mode	MP			
>FDD				
>>CHOICE measurement quantity	MP			
>>>CPICH Ec/No			Integer(-20..0)	In dB
>>>CPICH RSCP			Integer(-115..-40)	In dBm
>>>Pathloss			Integer(46..158)	In dB
>TDD				
>>Timeslot List	OP	1 to 14		
>>>Timeslot ISCP	MP		Timeslot ISCP info 10.3.7.90	The UE shall report the Timeslot ISCP in the same order as indicated in the cell info
>>Primary CCPCH RSCP	OP		Primary CCPCH RSCP info 10.3.7.79	
Measurement results for monitored cells	OP	1 to 7		
>SFN-SFN observed time difference	OP		SFN-SFN observed time difference 10.3.7.88	It is absent for current cell
>CHOICE mode	MP			
>>FDD				
>>>Primary CPICH info	MP		Primary CPICH info 10.3.6.59	
>>>CHOICE measurement quantity	OP			It is absent for current cell
>>>>CPICH Ec/No			Integer(-20..0)	In dB
>>>>CPICH RSCP			Integer(-115..-40)	In dBm
>>>>Pathloss			Integer(46..158)	In dB
>>TDD				
>>>Cell parameters Id	MP		Cell parameters Id 10.3.6.8	
>>>Primary CCPCH RSCP	MP		Primary CCPCH RSCP info 10.3.7.79	

NOTE 1: Monitored cells consist of current cell and neighbouring cells.

10.3.7.71 Measurement Command

Information Element/Group name	Need	Multi	Type and reference	Semantics description
Measurement command	MP		Enumerated(Setup,Modify,Release)	

10.3.7.72 Measurement control system information

Information element/Group name	Need	Multi	Type and reference	Semantics description
Use of HCS	MP		Enumerated (Not used, used)	Indicates if the serving cell belongs to a HCS structure
Cell_selection_and_reselection_quality_measure	MP		Enumerated (CPICH Ec/N0, CPICH RSCP)	Choice of measurement (CPICH Ec/N0 or CPICH RSCP) to use as quality measure Q.
Intra-frequency measurement system information	OP		Intra-frequency measurement system information 10.3.7.40	
Inter-frequency measurement system information	OP		Inter-frequency measurement system information 10.3.7.20	
Inter-system measurement system information	OP		Inter-system measurement system information 10.3.7.31	
Traffic volume measurement system information	OP		Traffic volume measurement system information 10.3.7.98	
UE Internal measurement system information	OP		UE Internal measurement system information 10.3.7.106	

NOTE1: The reporting of intra-frequency measurements is activated when state CELL_DCH is entered.

10.3.7.73 Measurement Identity Number

A reference number that is used by the UTRAN at modification and release of the measurement, and by the UE in the measurement report.

Information Element/Group name	Need	Multi	Type and reference	Semantics description
Measurement identity number	MP		Integer(1..16)	

10.3.7.74 Measurement reporting mode

Contains the type of Measurement Report transfer mode and the indication of periodical/event trigger.

Information Element/Group name	Need	Multi	Type and reference	Semantics description
Measurement Report Transfer Mode	MP		enumerated (Acknowledged mode RLC, Unacknowledged mode RLC)	
Periodical Reporting / Event Trigger Reporting Mode	MP		Enumerated (Periodical reporting, Event trigger)	

10.3.7.75 Measurement Type

Information Element/Group name	Need	Multi	Type and reference	Semantics description
Measurement Type	MP		Enumerated (Intra-frequency, Inter-frequency, Inter-system, Traffic volume, Quality, UE internal, LCS)	

10.3.7.76 Measurement validity

Information Element/Group name	Need	Multi	Type and reference	Semantics description
Resume/release	MP		Enumerated ('resume', 'release')	Indicates whether a given measurement identifier should be released after transitions to CELL_DCH and/or transitions from CELL_DCH state.
UE state	CV – Resume		Enumerated (CELL_DCH, all states except CELL_DCH, all states)	Indicates the states, in which measurement reporting shall be conducted. The values 'all states except CELL_DCH' and 'all states' are used for measurement type 'traffic volume reporting'.

Condition	Explanation
Resume	This IE is mandatory if "Resume/Release" = Resume, otherwise the IE is not needed

10.3.7.77 Observed time difference to GSM cell

Information Element/Group name	Need	Multi	Type and reference	Semantics description
Observed time difference to GSM cell	OP		Real(0.0..4095*3060/(4096*13) by step of 3060/(4096*13))	In ms

10.3.7.78 Periodical reporting criteria

Contains the periodical reporting criteria information. It is necessary only in the periodical reporting mode.

Information Element/Group name	Need	Multi	Type and reference	Semantics description
Amount of reporting	MD		Integer(1, 2, 4, 8, 16, 32, 64, Infinity)	Measurement is "released" after the indicated amount of reporting from the UE itself. The default value is infinity.
Reporting interval	MP		Integer(250, 500, 1000, 2000, 3000, 4000, 6000, 8000, 12000, 16000, 20000, 24000, 28000, 32000, 64000)	Indicates the interval of periodical report. Interval in milliseconds

10.3.7.79 Primary CCPCH RSCP info

NOTE: Only for TDD

Information Element/Group name	Need	Multi	IE type and reference	Semantics description
Primary CCPCH RSCP	MP		Enumerated (-115, -114 ... -25)	Granularity 1dB

10.3.7.80 Quality measured results list

Information Element/Group name	Need	Multi	Type and reference	Semantics description
BLER measurement results	OP	1 to <maxTrCH >		
>DL Transport channel identity	MP		Transport channel identity 10.3.5.18	
>DL Transport Channel BLER	OP		Real(0.00 ..1.00, by step of 0.02)	In dB= -Log10(Transport channel BLER)
CHOICE mode				
>FDD				
>>SIR	OP		Integer(-10..20)	In dB
>TDD				
>>SIR measurement results	OP	1 to <MaxCCTrCH>		SIR measurements for DL CCTrCH
>>>TFCS ID	MP		Enumerated (1...8)	
>>>Timeslot list	MP	1 to <maxTS>		for all timeslot on which the CCTrCH is mapped on
>>>>SIR	MP		Integer(-10..20)	the UE shall report in ascending timeslot order

10.3.7.81 Quality measurement

Information Element/Group name	Need	Multi	Type and reference	Semantics description
Quality reporting quantity	OP		Quality reporting quantity 10.3.7.84	
CHOICE report criteria	MP			
>Quality measurement reporting criteria			Quality measurement reporting criteria 10.3.7.83	
>Periodical reporting criteria			Periodical reporting criteria 10.3.7.78	
>No reporting				(no data) Chosen when this measurement only is used as additional measurement to another measurement

10.3.7.82 Quality measurement event results (FFS)

Information Element/Group name	Need	Multi	Type and reference	Semantics description
Transport channels causing the event	OP	1 to <maxTrCH >		
>Transport channel identity	MP		Transport channel identity 10.3.5.18	

10.3.7.83 Quality measurement reporting criteria

Event 5a: Number of bad CRCs on a certain transport channel exceeds a threshold.

Information Element/Group name	Need	Multi	Type and reference	Semantics description
Parameters sent for each transport channel	OP	1 to <maxTrCH >		
>Transport channel identity	MP		Transport channel identity 10.3.5.18	
>Total CRC	MP		Integer(1..512)	Number of CRCs
>Bad CRC	MP		Integer(1..512)	Number of CRCs
>Pending after trigger	MP		Integer(1..512)	Number of CRCs

10.3.7.84 Quality reporting quantity

Information Element/Group name	Need	Multi	Type and reference	Semantics description
DL Transport Channel BLER	MP		Boolean	TRUE means report requested
Transport channels for BLER reporting	CV BLER reporting	1 to <maxTrCH >		The default, if no transport channel identities are present, is that the BLER is reported for all downlink transport channels
>DL Transport channel identity	MP		Transport channel identity 10.3.5.18	
CHOICE mode				
>FDD				
>>SIR	MP		Boolean	TRUE means report requested
>TDD				
>>SIR measurement list	OP	1 to <maxCCTrCH>		SIR measurements shall be reported for all listed TFCS IDs
>>>TFCS ID	MP		Enumerated (1...8)	

Condition	Explanation
BLER reporting	This information element is absent if 'DL Transport Channel BLER' is 'False' and optional, if 'DL Transport Channel BLER' is 'True'

10.3.7.85 Reference time difference to cell

In the System Information message, the reference time difference to cell indicates the SFN-SFN time difference between the primary CCPCH of the current cell and the primary CCPCH of a neighbouring cell..

In the Measurement Control message, the reference time difference to cell indicates the CFN-SFN time difference between UE uplink transmission timing and the primary CCPCH of a neighbouring cell.

Information Element/Group name	Need	Multi	Type and reference	Semantics description
CHOICE accuracy	MP			
>40 chips				
>>Reference time difference	MP		Integer(0..38400 by step of 40)	In chips
>256 chips				
>>Reference time difference	MP		Integer(0..38400 by step of 256)	In chips
>2560 chips				
>>Reference time difference	MP		Integer(0..38400 by step of 2560)	In chips

10.3.7.86 Reporting Cell Status

Indicates maximum allowed number of cells to report and whether active set cells and/or virtual active set cells and/or monitored set cells on used frequency and/or monitored set cells on non used frequency should/should not be included in the IE "Measured results".

Information Element/Group name	Need	Multi	Type and reference	Semantics description
Choice reporting cell	MP			
>Within active set cells				
>> Maximum number of reporting cells type1	MP		Integer(1..6)	
>Within monitored set cells on used frequency				
>> Maximum number of reporting cells type1	MP		Integer(1..6)	
>Within monitored cells on used frequency				
>> Maximum number of reporting cells type1	MP		Integer(1..6)	
>Include all active set cells + within monitored set cells on used frequency				
>> Maximum number of reporting cells type3	MP		Enumerated (virtual/active set cells+1, virtual/active set cells+2,, virtual/active set cells+6)	
>Within virtual active set cells				
>> Maximum number of reporting cells type1	MP		Integer(1..6)	
>Within monitored set cells on non-used frequency				
>> Maximum number of reporting cells type1	MP		Integer(1..6)	
>Within monitored cells on non-used frequency				
>> Maximum number of reporting cells type1	MP		Integer(1..6)	
>Include all virtual active set cells + within monitored set cells on non-used frequency				
>> Maximum number of reporting cells type3	MP		Enumerated (virtual/active set cells+1, virtual/active set cells+2,, virtual/active set cells+6)	
>Within active set cells or within virtual active set cells				
>> Maximum number of reporting cells type2	MP		Integer (1..12)	
>Within monitored cells on used frequency or within monitored cells on non-used frequency				
>> Maximum number of reporting cells type2	MP		Integer(1..12)	

NOTE: Monitored cells consist of active set cells and monitored set cells

10.3.7.87 Reporting information for state CELL_DCH

Information Element/Group name	Need	Multi	Type and reference	Semantics description
Intra-frequency reporting quantity	MP		Intra-frequency reporting quantity 10.3.7.41	
Measurement Reporting Mode	MP		Measurement Reporting Mode 10.3.7.74	
CHOICE report criteria	MP			
>Intra-frequency measurement reporting criteria			Intra-frequency measurement reporting criteria 10.3.7.39	
>Periodical reporting criteria			Periodical reporting criteria 10.3.7.78	

10.3.7.88 SFN-SFN observed time difference

Information Element/Group name	Need	Multi	Type and reference	Semantics description
CHOICE type	MP			
>Type 1			Integer(0..9830399)	Number of chips
>Type 2			Real(-1279.75..1280.0 by step of 0.25)	Number of chips

10.3.7.89 Time to trigger

Information Element/Group name	Need	Multi	Type and reference	Semantics description
Time to trigger	MP		Integer(0, 10, 20, 40, 60, 80, 100, 120, 160, 200, 240, 320, 640, 1280, 2560, 5000)	Indicates the period of time between the timing of event detection and the timing of sending Measurement Report. Time in ms

10.3.7.90 Timeslot ISCP info

NOTE: Only for TDD

Information Element/Group name	Need	Multi	IE type and reference	Semantics description
Timeslot ISCP	MP		Integer (-115... -25)	In dBm

10.3.7.91 Traffic volume event identity

Information Element/Group name	Need	Multi	Type and reference	Semantics description
Traffic volume event identity	MP		Enumerated(4a, 4b)	

10.3.7.92 Traffic volume measured results list

Information Element/Group name	Need	Multi	Type and reference	Semantics description
Traffic volume measurement results	OP	1 to <maxRB >		
>RB Identity	MP		RB Identity 10.3.4.16	
>RLC buffers payload	OP		Enumerated(0, 4, 8, 16, 32, 64, 128, 256, 512, 1024, 2K, 4K, 8K, 16K, 32K, 64K, 128K, 256K, 512K, 1024K)	In bytes And N Kbytes = N*1024 bytes
>Average RLC buffer payload	OP		Enumerated(0, 4, 8, 16, 32, 64, 128, 256, 512, 1024, 2K, 4K, 8K, 16K, 32K, 64K, 128K, 256K, 512K, 1024K)	In bytes And N Kbytes = N*1024 bytes
>Variance of RLC buffer payload	OP		Enumerated(0, 4, 8, 16, 32, 64, 128, 256, 512, 1024, 2K, 4K, 8K, 16K)	In bytes And N Kbytes = N*1024 bytes

10.3.7.93 Traffic volume measurement

Information Element/Group name	Need	Multi	Type and reference	Semantics description
Traffic volume measurement Object	OP		Traffic volume measurement Object 10.3.7.95	
Traffic volume measurement quantity	OP		Traffic volume measurement quantity 10.3.7.96	
Traffic volume reporting quantity	OP		Traffic volume reporting quantity 10.3.7.99	
Measurement validity	OP		Measurement validity 10.3.7.76	
CHOICE report criteria	MP			
>Traffic volume measurement reporting criteria			Traffic volume measurement reporting criteria 10.3.7.97	
>Periodical reporting criteria			Periodical reporting criteria 10.3.7.78	
>No reporting				(no data) Chosen when this measurement only is used as additional measurement to another measurement

10.3.7.94 Traffic volume measurement event results

Contains the event result for a traffic volume measurement.

Information Element/Group name	Need	Multi	Type and reference	Semantics description
UL Transport Channel causing the event	MP		Transport channel identity 10.3.5.18	
Traffic volume event identity	MP		Traffic volume event identity 10.3.7.91	

10.3.7.95 Traffic volume measurement object

Contains the measurement object information for a traffic volume measurement.

Information Element/Group name	Need	Multi	Type and reference	Semantics description
Traffic volume measurement objects	MP	1 to <maxTrCH >		
>UL Target Transport Channel ID	MP		Transport channel identity 10.3.5.18	

10.3.7.96 Traffic volume measurement quantity

Contains the measurement quantity information for a traffic volume measurement.

Information Element/Group name	Need	Multi	Type and reference	Semantics description
Measurement quantity	MP		Enumerated(RLC buffer payload, Average RLC buffer payload, Variance of RLC buffer payload)	
Time Interval to take an average or a vaiance	CV-A/V		Integer(20, 40, ..260, by steps of 20)	In ms At least 3 spare values, Criticality: reject, are needed.

Condition	Explanation
A/V	This IE is present when "Average RLC buffer" or "Variance of RLC buffer payload" is chosen.

10.3.7.97 Traffic volume measurement reporting criteria

Contains the measurement reporting criteria information for a traffic volume measurement.

Event 4a: RLC buffer payload exceeds an absolute threshold.

Event 4b: RLC buffer payload becomes smaller than an absolute threshold.

Information Element/Group name	Need	Multi	Type and reference	Semantics description
Parameters sent for each transport channel	OP	1 to <maxTrCH >		
>UL Transport Channel ID	OP		Transport channel identity 10.3.5.18	If the transport channel identity is not included, the measurement reporting criteria are applied to all transport channels.
>Parameters required for each Event	OP	1 to <maxMeas perEvent>		
>>Traffic volume event identity	MP		Traffic volume event identity 10.3.7.91	
>>Reporting Threshold	MP		Enumerated(8,16,32,64,128,256,512,1024,2K,3K,4K,6K,8K,12K,16K,24K,32K,48K,64K,96K,128K,192K,256K,384K,512K,768K)	Threshold in bytes And N Kbytes = N*1024 bytes
Time to trigger	OP		Time to trigger 10.3.7.89	Indicates the period of time between the timing of event detection and the timing of sending Measurement Report. Time in ms
Pending time after trigger	OP		Integer(250, 500, 1000, 2000, 4000, 8000, 16000)	Time in seconds. Indicates the period of time during which it is forbidden to send any new measurement reports with the same measurement ID even if the triggering condition is fulfilled again. Time in milliseconds
Tx interruption after trigger	OP		Integer (250, 500, 1000, 2000, 4000, 8000, 16000)	Time in milliseconds. Indicates whether or not the UE shall block DTCH transmissions on the RACH after a measurement report is triggered.
Amount of reporting	OP		Integer(1, 2, 4, 8, 16, 32, 64, Infinity)	Measurement is "released" after the indicated amount of reporting from the UE itself.

10.3.7.98 Traffic volume measurement system information

Information Element/Group name	Need	Multi	Type and reference	Semantics description
Traffic volume measurement identity number	MD		Measurement identity number 10.3.7.73	The traffic volume measurement identity number has default value 4.
Traffic volume measurement objects	OP		Traffic volume measurement objects 10.3.7.95	
Traffic volume measurement quantity	OP		Traffic volume measurement quantity 10.3.7.96	
Traffic volume reporting quantity	OP		Traffic volume reporting quantity 10.3.7.99	
Measurement validity	OP		Measurement validity 10.3.7.76	
Measurement Reporting Mode	MP		Measurement Reporting Mode 10.3.7.74	
CHOICE reporting criteria	MP			
>Traffic volume measurement reporting criteria			Traffic volume measurement reporting criteria 10.3.7.97	
>Periodical reporting criteria			Periodical reporting criteria 10.3.7.78	

10.3.7.99 Traffic volume reporting quantity

Contains the reporting quantity information for a traffic volume measurement.

For all boolean types TRUE means inclusion in the report is requested.

Information Element/Group name	Need	Multi	Type and reference	Semantics description
RLC buffer payload for each RB	MP		Boolean	
Average RLC buffer payload for each RB	MP		Boolean	
Variance of RLC buffer payload for each RB	MP		Boolean	

10.3.7.100 UE internal event identity

Information Element/Group name	Need	Multi	Type and reference	Semantics description
UE internal event identity	MP		Enumerated(6a,6b,6c,6d,6e,6f,6g)	

10.3.7.101 UE internal measured results

Information Element/Group name	Need	Multi	Type and reference	Semantics description
CHOICE mode	MP			
>FDD				
>>UE Transmitted Power	OP		Integer(-50..33)	UE transmitted power In dBm
>>UE Rx-Tx report entries	OP	1 to <maxRL >		
>>>Primary CPICH info	MP		Primary CPICH info 10.3.6.59	Primary CPICH info for each cell included in the active set
>>>UE Rx-Tx time difference	MP		UE Rx-Tx time difference 10.3.7.108	UE Rx-Tx time difference in chip for each RL included in the active set
>TDD				
>>UE transmitted Power list	OP	1 to <maxTS >		UE transmitted power for each used uplink timeslot in ascending timeslot number order
>>>UE transmitted power	MP		UE transmitted power info 10.3.7.109	
>>Applied TA	OP		Uplink Timing Advance 10.3.6.93	

10.3.7.102 UE internal measurement

Information Element/Group name	Need	Multi	Type and reference	Semantics description
UE internal measurement quantity	OP		UE internal measurement quantity 10.3.7.104	
UE internal reporting quantity	OP		UE internal reporting quantity 10.3.7.107	
CHOICE report criteria	MP			
>UE internal measurement reporting criteria			UE internal measurement reporting criteria 10.3.7.105	
>Periodical reporting criteria			Periodical reporting criteria 10.3.7.78	
>No reporting				(no data) Chosen when this measurement only is used as additional measurement to another measurement

CHOICE report criteria	Condition under which the given report criteria is chosen
UE internal measurement reporting criteria	Chosen when UE internal measurement event triggering is required
Periodical reporting criteria	Chosen when periodical reporting is required
No reporting	Chosen when this measurement only is used as additional measurement to another measurement

10.3.7.103 UE internal measurement event results

This IE contains the measurement event results that are reported to UTRAN for UE internal measurements.

Information Element/Group name	Need	Multi	Type and reference	Semantics description
UE internal event identity	MP		UE internal event identity 10.3.7.100	
CHOICE mode	MP			
>FDD				
>Primary CPICH info	CV - clause 1		Primary CPICH info 10.3.6.59	
>TDD				(no data)

Condition	Explanation
Clause 1	This IE is mandatory if "UE internal event identity" is set to "6f" or "6g", otherwise the IE is not needed

10.3.7.104 UE internal measurement quantity

The quantity the UE shall measure in case of UE internal measurement.

Information Element/Group name	Need	Multi	Type and reference	Semantics description
CHOICE mode	MP			
>FDD				
>>Measurement quantity	MP		Enumerated(UE Transmitted Power, UTRA Carrier RSSI, UE Rx-Tx time difference)	
>TDD				
>>Measurement quantity	MP		Enumerated(UE Transmitted Power, UTRA Carrier RSSI)	
Filter coefficient	MP		Filter coefficient 10.3.7.9	

10.3.7.105 UE internal measurement reporting criteria

The triggering of the event-triggered reporting for a UE internal measurement. All events concerning UE internal measurements are labelled 6x where x is a, b, c.... In TDD, the events 6a - 6d are measured and reported on timeslot basis.

Event 6a: The UE Transmitted Power becomes larger than an absolute threshold

Event 6b: The UE Transmitted Power becomes less than an absolute threshold

Event 6c: The UE Transmitted Power reaches its minimum value

Event 6d: The UE Transmitted Power reaches its maximum value

Event 6e: The UE RSSI reaches the UEs dynamic receiver range

Event 6f: The UE Rx-Tx time difference for a RL included in the active set becomes larger than an absolute threshold

Event 6g: The UE Rx-Tx time difference for a RL included in the active set becomes less than an absolute threshold

Information Element/Group name	Need	Multi	Type and reference	Semantics description
Parameters sent for each UE internal measurement event	OP	1 to <maxMeas Event>		
> UE internal event identity	MP		UE internal event identity 10.3.7.100	
>Time-to-trigger	MP		Integer(0, 10, 20, 40, 60, 80, 100, 120, 160, 200, 240, 320, 640, 1280, 2560, 5000)	Time in ms. Indicates the period of time between the timing of event detection and the timing of sending Measurement Report.
>UE Transmitted power Tx power threshold	CV - clause 1		Integer(-50..33)	Power in dBm. In event 6a, 6b.
>UE Rx-Tx time difference threshold	CV - clause 2		Integer(769..1280)	Time difference in chip. In event 6f, 6g.

Condition	Explanation
Clause 1	The IE is mandatory if "UE internal event identity" is set to "6a" or "6b", otherwise the IE is not needed
Clause 2	The IE is mandatory if "UE internal event identity" is set to "6f" or "6g", otherwise the IE is not needed

10.3.7.106 UE internal measurement system information

Information Element/Group name	Need	Multi	Type and reference	Semantics description
UE internal measurement identity number	MD		Measurement identity number 10.3.7.73	The UE internal measurement identity number has default value 5.
UE internal measurement quantity	MP		UE internal measurement quantity 10.3.7.104	

10.3.7.107 UE Internal reporting quantity

For all boolean types TRUE means inclusion in the report is requested.

Information Element/Group name	Need	Multi	Type and reference	Semantics description
UE Transmitted Power	MP		Boolean	
CHOICE mode	MP			
>FDD				
>>UE Rx-Tx time difference	MP		Boolean	
>TDD				
>>Applied TA	MP		Boolean	

10.3.7.108 UE Rx-Tx time difference

The difference in time between the UE uplink DPCCH/DPDCH frame transmission and the first significant path, of the downlink DPCH frame from the measured radio link. This measurement is for FDD only.

Information Element/Group name	Need	Multi	Type and reference	Semantics description
UE Rx-Tx time difference	MP		Integer(876..1172)	In chips.

10.3.7.109 UE Transmitted Power info

Information Element/Group name	Need	Multi	IE type and reference	Semantics description
UE Transmitted Power	MP		Integer (-50... 33)	In dB

10.3.8 Other Information elements

10.3.8.1 BCCH modification info

Indicates modification of the System Information on BCCH.

Information Element/Group name	Need	Multi	Type and reference	Semantics description
MIB Value tag	MP		MIB Value tag 10.3.8.7	
BCCH Modification time	OP		Integer (0..8, 16, 24, .. 4088)	All SFN values in which MIB may be mapped are allowed.

10.3.8.2 BSIC

Information Element/Group name	Need	Multi	Type and reference	Semantics description
Base transceiver Station Identity Code (BSIC)	MP			[TS 23.003]
>Network Colour Code (NCC)	MP		bit string(3)	
>Base Station Colour Code (BCC)	MP		bit string(3)	

10.3.8.3 CBS DRX Level 1 information

This information element contains the CBS discontinuous reception information to be broadcast for CBS DRX Level 1 calculations in the UE.

Information Element/Group name	Need	Multi	Type and reference	Semantics description
Period of CTCH allocation (N)	MP		Integer (1..256)	$MTTI \leq N \leq 4096 - K$, N multiple of MTTI
CBS frame offset (K)	MP		Integer (0..255)	$0 \leq K \leq N-1$, K multiple of MTTI

10.3.8.4 Cell Value tag

Information Element/Group name	Need	Multi	Type and reference	Semantics description
Cell Value tag	MP		Integer (1..4)	

10.3.8.5 Inter-System handover failure

Information Element/Group name	Need	Multi	Type and reference	Semantics description
Inter-System handover failure cause	MD		Enumerated(Configuration unacceptable, physical channel failure, protocol error, unspecified)	Default value is "unspecified". At least 3 spare values, criticality = default, are required
Protocol error information	CV-ProtErr		Protocol error information 10.3.8.10	
Inter-System message	OP		Inter-System message 10.3.8.6	

Condition	Explanation
ProtErr	If the IE "Inter-system handover failure cause" has the value "Protocol error"

10.3.8.6 Inter-system message

This Information Element contains one or several messages that are structured and coded according to the specification used for the system type indicated by the first parameter.

Information Element/Group name	Need	Multi	Type and reference	Semantics description
System type	MP		Enumerated (GSM except PCS 1900, PCS 1900, cdma2000)	This IE indicates in particular which specification to apply to decode the transported messages At least 14 spare values, Criticality: reject, are needed
CHOICE system	MP			At least 14 spare choices, Criticality: reject, are needed
>GSM				
>>Message(s)	MP	1.to.<maxlnterSysMessages>	Bitstring (1..512)	Formatted and coded according to GSM specifications
>cdma2000				
>>cdma2000Message	MP	1.to.<maxlnterSysMessages>		
>>>MSG_TYPE(s)	MP		Bitstring (8)	Formatted and coded according to cdma2000 specifications
>>>cdma2000Messagepayload(s)	MP		Bitstring (1..512)	Formatted and coded according to cdma2000 specifications

Condition	Explanation
System	The 'GSM' choice shall be applied when the IE 'System type' is 'GSM except PCS 1900' or 'PCS 1900', and the 'cdma2000' choice shall be applied when the IE 'system type' is 'cdma2000'.

10.3.8.7 MIB Value tag

Information Element/Group name	Need	Multi	Type and reference	Semantics description
MIB Value tag	MP		Integer (1..8)	

10.3.8.8 PLMN Value tag

Information Element/Group name	Need	Multi	Type and reference	Semantics description
PLMN Value tag	MP		Integer (1..256)	

10.3.8.9 Predefined configuration identity and value tag

Information Element/Group name	Need	Multi	Type and reference	Semantics description
Predefined configuration identity	MP		Predefined configuration identity 10.3.4.5	
Predefined configuration value tag	MP		Predefined configuration value tag 10.3.4.6	

10.3.8.10 Protocol error information

This information element contains diagnostics information returned by the receiver of a message that was not completely understood.

Information Element/Group name	Need	Multi	Type and reference	Semantics description
CHOICE diagnostics type	MP			At least one spare choice is needed.
> Protocol error cause			Protocol error cause 10.3.3.26	

10.3.8.11 References to other system information blocks

Information element/Group name	Need	Multi	Type and reference	Semantics description
References to other system information blocks	MP	1 to <maxSIB>		System information blocks for which multiple occurrences are used, may appear more than once in this list
>Scheduling information	MP		Scheduling information, 10.3.8.12	

10.3.8.12 Scheduling information

Information Element/Group name	Need	Multi	Type and reference	Semantics description
SIB type	MP		SIB Type, 10.3.8.17	
CHOICE Value tag	OP			
>PLMN Value tag			PLMN Value tag 10.3.8.8	This IE is included if the following conditions are fulfilled: the area scope for the system information block is set to "PLMN" in table 8.1.1. a value tag is used to indicate changes in the system information block. the SIB type does not equal system information block type 16
>Predefined configuration identity and value tag			Predefined configuration identity and value tag 10.3.8.9	This IE is included if the following conditions are fulfilled: the SIB type equals system information block type 16
>Cell Value tag			Cell Value tag 10.3.8.4	This IE is included if the following conditions are fulfilled: the area scope for the system information block is set to "cell" in table 8.1.1. a value tag is used to indicate changes in the system information block.
Scheduling	MD			see below for default value
>SEG_COUNT	MD		SEG COUNT 10.3.8.13	Default value is 1
>SIB_REP	MP		Integer (4, 8, 16, 32, 64, 128, 256, 512, 1024, 2048, 4096)	Repetition period for the SIB in frames
>SIB_POS	MP		Integer (0 ..Rep-2 by step of 2)	Position of the first segment Rep is the value of the SIB_REP IE
>SIB_POS offset info	MD	1..15		see below for default value
>>SIB_OFF	MP		Integer(2..32 by step of 2)	Offset of subsequent segments

Field	Default value
SIB_POS offset info	The default value is that all segments are consecutive, i.e., that the SIB_OFF = 2 for all segments except when MIB segment/complete MIB is scheduled to be transmitted in between segments from same SIB. In that case, SIB_OFF=4 in between segments which are scheduled to be transmitted at SFN _{prime} = 8 *n-2 and 8*n + 2, and SIB_OFF=2 for the rest of the segments.
Scheduling	The default value is the scheduling of the SIB as specified in another SIB.

10.3.8.13 SEG COUNT

Information Element/Group name	Need	Multi	Type and reference	Semantics description
SEG_COUNT	MP		Integer (1..16)	Number of segments in the system information block

10.3.8.14 Segment index

Each system information segment has an individual segment index.

Information Element/Group name	Need	Multi	Type and reference	Semantics description
Segment index	MP		Integer (0..15)	Segments of a system information block are numbered starting with 0 for the first part.

10.3.8.15 SIB data fixed

Contains the result of a master information block or a system information block after encoding and segmentation. The IE is used for segments with fixed length (segments filling an entire transport block).

Information Element/Group name	Need	Multi	Type and reference	Semantics description
SIB data fixed	MP		Bit string (222)	

10.3.8.16 SIB data variable

Contains either a complete system information block or a segment of a system information block. Contains the result of a master information block or a system information block after encoding and segmentation. The IE is used for segments with variable length. The system information blocks are defined in clauses 10.2.49.8.1 to 10.2.49.8.18.

Information Element/Group name	Need	Multi	Type and reference	Semantics description
SIB data variable	MP		Bit string (1..214)	

10.3.8.17 SIB type

The SIB type identifies a specific system information block.

Information Element/Group name	Need	Multi	Type and reference	Semantics description
SIB type	MP		Enumerated, see below	

The list of values to encode is:

- Master information block,
- System Information Type 1,
- System Information Type 2,
- System Information Type 3,
- System Information Type 4,

System Information Type 5,
 System Information Type 6,
 System Information Type 7,
 System Information Type 8,
 System Information Type 9,
 System Information Type 10,
 System Information Type 11,
 System Information Type 12,
 System Information Type 13,
 System Information Type 13.1,
 System Information Type 13.2,
 System Information Type 13.3,
 System Information Type 13.4,
 System Information Type 14,
 System Information Type 15,
 System Information Type 15.1,
 System Information Type 15.2,
 System Information Type 15.3,
 System Information Type 16,
 System Information Type 17

in addition, at least 7 spare values, criticality: ignore, are needed.

10.3.9 ANSI-41 Information elements

10.3.9.1 ANSI 41 Core Network Information

Information element/Group name	Need	Multi	Type and reference	Semantics description
P_REV	MP		P_REV 10.3.9.10	
MIN_P_REV	MP		MIN_P_REV 10.3.9.8	
SID	MP		SID 10.3.9.11	
NID	MP		NID 10.3.9.9	

10.3.9.2 ANSI-41 Global Service Redirection information

This Information Element contains ANSI-41 Global Service Redirection information.

Information Element/Group name	Need	Multi	Type and reference	Semantics description
ANSI-41 Global Service Redirection information	MP		ANSI-41 NAS parameter, 10.3.9.3	Formatted and coded according to the 3GPP2 document "G3G CDMA DS on ANSI-41"

10.3.9.3 ANSI-41 NAS parameter

This Information Element contains ANSI-41 User Zone Identification information.

Information Element/Group name	Need	Multi	Type and reference	Semantics description
ANSI-41 NAS parameter	MP		Bit string (size (1..2048))	

10.3.9.4 ANSI-41 NAS system information

This Information Element contains ANSI-41 system information.

Information Element/Group name	Need	Multi	Type and reference	Semantics description
NAS (ANSI-41) system information	MP		ANSI-41 NAS parameter, 10.3.9.3	Formatted and coded according to the 3GPP2 document "G3G CDMA DS on ANSI-41"

10.3.9.5 ANSI-41 Private Neighbor/Neighbour List information

This Information Element contains ANSI-41 Private Neighbor/Neighbour List information.

Information Element/Group name	Need	Multi	Type and reference	Semantics description
ANSI-41 Private Neighbor/Neighbour List information	MP		ANSI-41 NAS parameter, 10.3.9.3	Formatted and coded according to the 3GPP2 document "G3G CDMA DS on ANSI-41"

10.3.9.6 ANSI-41 RAND information

This Information Element contains ANSI-41 RAND information.

Information Element/Group name	Need	Multi	Type and reference	Semantics description
ANSI-41 RAND information	MP		ANSI-41 NAS parameter, 10.3.9.3	Formatted and coded according to the 3GPP2 document "G3G CDMA DS on ANSI-41"

10.3.9.7 ANSI-41 User Zone Identification information

This Information Element contains ANSI-41 User Zone Identification information.

Information Element/Group name	Need	Multi	Type and reference	Semantics description
ANSI-41 User Zone Identification information	MP		ANSI-41 NAS parameter, 10.3.9.3	Formatted and coded according to the 3GPP2 document "G3G CDMA DS on ANSI-41"

10.3.9.8 MIN_P_REV

This Information Element contains minimum protocol revision level.

Information Element/Group name	Need	Multi	Type and reference	Semantics description
MIN_P_REV	MP		Bitstring (8)	Minimum protocol revision level

10.3.9.9 NID

This Information Element contains Network identification.

Information Element/Group name	Need	Multi	Type and reference	Semantics description
NID	MP		Bitstring (16)	Network identification

10.3.9.10 P_REV

This Information Element contains protocol revision level.

Information Element/Group name	Need	Multi	Type and reference	Semantics description
P_REV	MP		Bitstring (8)	Protocol revision level

10.3.9.11 SID

This Information Element contains System identification.

Information Element/Group name	Need	Multi	Type and reference	Semantics description
SID	MP		Bitstring (15)	System identification

10.3.10 Multiplicity values and type constraint values

The following table includes constants that are either used as multi bounds (name starting with "max") or as high or low value in a type specification (name starting with "lo" or "hi"). Constants are specified only for values appearing more than once in the RRC specification. In case a constant is related to one or more other constants, an expression is included in the "value" column instead of the actual value.

Constant	Explanation	Value
CN information		
maxCNdomains	Maximum number of CN domains	4
maxSignallingFlow	Maximum number of flow identifiers	16
UTRAN mobility information		
maxRAT	Maximum number of Radio Access Technologies	maxOtherRAT + 1
maxOtherRAT	Maximum number of other Radio Access Technologies	15
maxURA	Maximum number of URAs in a cell	8
maxInterSysMessages	Maximum number of Inter System Messages	4
maxRABsetup	Maximum number of RABs to be established	16
UE information		
maxtransactions	Maximum number of parallel RRC transactions in downlink	25
maxPDCPalgoType	Maximum number of PDCP algorithm types	8
maxDRACclasses	Maximum number of UE classes which would require different DRAC parameters	8
maxFrequencybands	Maximum number of frequency bands supported by the UE as defined in 25.102	4
maxPage1	Number of UEs paged in the Paging Type 1 message	8
maxSystemCapability	Maximum number of system specific capabilities that can be requested in one message.	16
RB information		
maxPredefConfig	Maximum number of predefined configurations	16
maxRB	Maximum number of RBs	32
maxSRBsetup	Maximum number of signalling RBs to be established	8
maxRBperRAB	Maximum number of RBs per RAB	8
maxRBallRABs	Maximum number of non signalling RBs	27
maxRBMuxOptions	Maximum number of RB multiplexing options	8
maxLoCHperRLC	Maximum number of logical channels per RLC entity	2
TrCH information		
maxTrCH	Maximum number of transport channels used in one direction (UL or DL)	32
maxTrCHpreconf	Maximum number of preconfigured Transport channels, per direction	16
maxCCTrCH	Maximum number of CCTrCHs	8
maxTF	Maximum number of different transport formats that can be included in the Transport format set for one transport channel	32
maxTF-CPCH	Maximum number of TFs in a CPCH set	16
maxTFC	Maximum number of Transport Format Combinations	1024
maxTFCI-1-Combs	Maximum number of TF CI (field 1) combinations	512
maxTFCI-2-Combs	Maximum number of TF CI (field 2) combinations	512
maxCPCHsets	Maximum number of CPCH sets per cell	16
maxSIBperMsg	Maximum number of complete system information blocks per SYSTEM INFORMATION message	16
maxSIB	Maximum number of references to other system information blocks.	32
maxSIB-FACH	Maximum number of references to system information blocks on the FACH	8
PhyCH information		
maxSubCh	Maximum number of sub-channels on PRACH	12
maxPCPCH-APsubCH	Maximum number of available sub-channels for AP signature on PCPCH	12
maxPCPCH-CDsubCH	Maximum number of available sub-channels for CD signature on PCPCH	12
maxSig	Maximum number of signatures on PRACH	16
maxPCPCH-APsig	Maximum number of available signatures for AP on PCPCH	16
maxPCPCH-CDsig	Maximum number of available signatures for CD on PCPCH	16
maxAC	Maximum number of access classes	16
maxASC	Maximum number of access service classes	8
maxASCmap	Maximum number of access class to access service classes mappings	7
maxASCpersist	Maximum number of access service classes for which persistence scaling factors are specified	6
maxPRACH	Maximum number of PRACHs in a cell	16
maxFACHPCH	Maximum number of FACHs and PCHs mapped onto one	8

	secondary CCPCHs	
maxRL	Maximum number of radio links	8
maxSCCPCH	Maximum number of secondary CCPCHs per cell	16
maxDPDCH-UL	Maximum number of DPDCHs per cell	6
maxDPCH-DLchan	Maximum number of channelization codes used for DL DPCH	8
maxDPCHcodesPerTS	Maximum number of codes for one timeslots (TDD)	16
maxPUSCH	Maximum number of PUSCHs	(8)
maxPDSCH	Maximum number of PDSCHs	8
maxPDSCHcodes	Maximum number of codes for PDSCH	16
maxPDSCH-TFCIgroups	Maximum number of TFCI groups for PDSCH	256
maxPDSCHcodeGroups	Maximum number of code groups for PDSCH	256
maxPCPCHs	Maximum number of PCPCH channels in a CPCH Set	64
maxPCPCH-SF	Maximum number of available SFs on PCPCH	7
maxTS	Maximum number of timeslots used in one direction (UL or DL)	14
HiPUSCHIdentities	Maximum number of PDSCH Identities	64
HiPDSCHIdentities	Maximum number of PDSCH Identities	64
Measurement information		
maxTGPS	Maximum number of transmission gap pattern sequences	6
maxAdditionalMeas	Maximum number of additional measurements for a given measurement identity	4
maxMeasEvent	Maximum number of events that can be listed in measurement reporting criteria	8
maxMeasParEvent	Maximum number of measurement parameters (e.g. thresholds) per event	2
maxMeasIntervals	Maximum number of intervals that define the mapping function between the measurements for the cell quality Q of a cell and the representing quality value	1
maxCellMeas	Maximum number of cells to measure	32
maxFreq	Maximum number of frequencies to measure	8
maxSat	Maximum number of satellites to measure	16
HiRM	Maximum number that could be set as rate matching attribute for a transport channel	256
Frequency information		
maxFDDFreqList	Maximum number of FDD carrier frequencies to be stored in USIM	4
maxTDDFreqList	Maximum number of TDD carrier frequencies to be stored in USIM	4
maxFDDFreqCellList	Maximum number of neighbouring FDD cells to be stored in USIM	32
maxTDDFreqCellList	Maximum number of neighbouring TDD cells to be stored in USIM	32
maxGSMCellList	Maximum number of GSM cells to be stored in USIM	32

11 Message and Information element abstract syntax
(with ASN.1)

12 Message transfer syntax

Transfer syntax for RRC PDUs is derived from their ASN.1 definitions by use of Packed Encoding Rules, unaligned (X.691), and with adapted final padding. If special encoding is used, it is indicated in the ECN module defined for each ASN.1 module. How special encoding is used is defined in TR 25.921.

12.1 Structure of encoded RRC messages

An RRC PDU, which is the bit string that is exchanged between peer entities/ across the radio interface, is the concatenation of a basic production, an extension and padding, in that order.

Basic production

The 'basic production' is obtained by applying UNALIGNED PER to the abstract syntax value (the ASN.1 description) as specified in X.691, except for the 0 to 7 bits added at the end to produce a multiple of 8 bits. The basic production can have any positive number of bits, not necessarily a multiple of 8 bits.

Extension

Emitters compliant with this version of the specification of the protocol shall, unless indicated otherwise on a PDU type basis, set the extension part empty. Emitters compliant with a later version might send non empty extensions.

Padding

Emitters compliant with this version of the specification of the protocol shall, unless indicated otherwise on a PDU type basis, pad the basic production with the smallest number of bits required to meet the size constraints of the lower layers. Padding bits shall be set to 0.

Receivers compliant with this version of the specification have no need to distinguish the extension and padding parts, and shall, unless indicated otherwise on a PDU type basis, accept RRC PDUs with any bit string in the extension and padding parts.

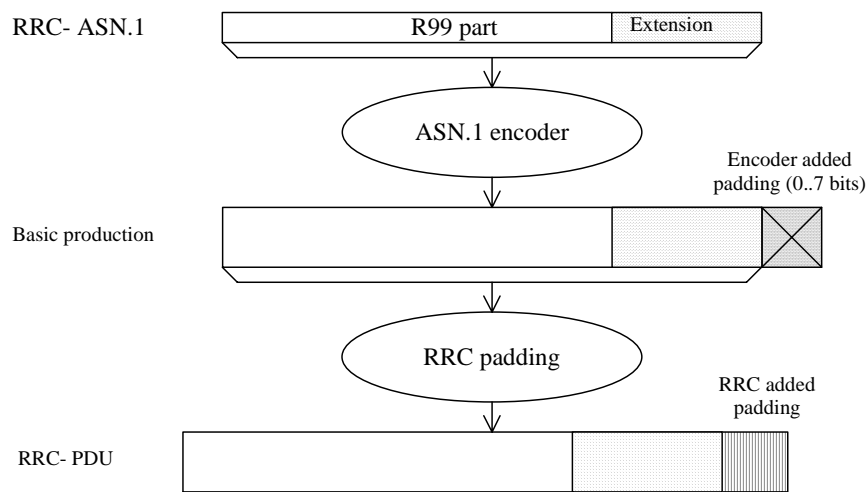

Figure 62: Padding

When using AM or UM mode, RLC requires that the RRC PDU length is a multiple of 8 bits.

When using Tr mode, RLC does neither impose size requirements nor perform padding. This implies that RRC has to take into account the transport format set defined for the transport channel across which the message is to be sent. RRC shall select the smallest transport format that fits the RRC PDU and shall add the lowest number of padding bits required to fit the size specified for the selected transport format.

For system information blocks, building the PDU involves two steps. The first step is the building of the SIBs, in which step padding is not applied (the rules for extension apply). The second step is the building of the RRC PDUs, involving segmentation and concatenation of SIBs, and then padding as described above for Tr mode. The procedure is shown by means of an example as described in Figure 63. The example includes two SIBs, SIBn and SIBn+1, of which only SIBn includes a protocol extension. The two SIBs used in the example don't require segmentation and are concatenated into one SYSTEM INFORMATION message.

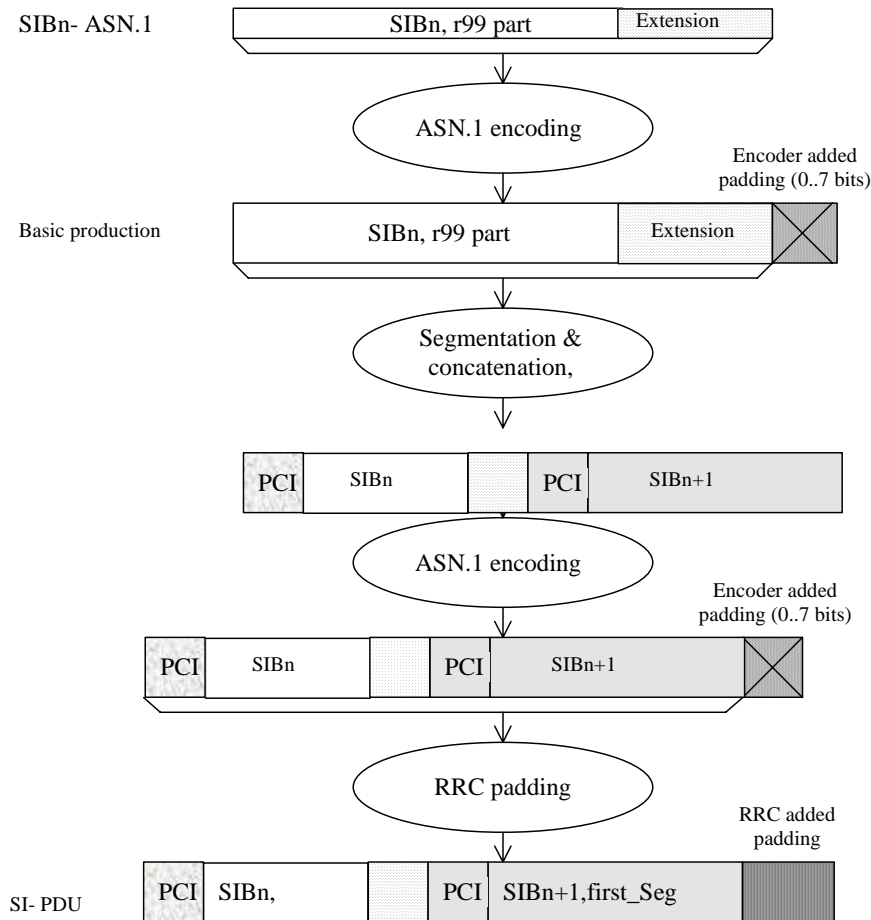

Figure 63: Padding for System Information

PCI: Protocol control information at SYSTEM INFORMATION message level

SI: SYSTEM INFORMATION message

12.2 ECN link module for RRC

```

RRC-ECN-Link-Module LINK-DEFINITIONS ::=
BEGIN
    Class-definitions ENCODED BY perUnaligned WITH Class-definitions-ECN-Module
    PDU-definitions ENCODED BY perUnaligned WITH PDU-definitions-ECN-Module
    CoreNetwork-IEs ENCODED BY perUnaligned WITH CoreNetwork-IEs-ECN-Module
    UTRANMobility-IEs ENCODED BY perUnaligned WITH UTRANMobility-IEs-ECN-Module
    UserEquipment-IEs ENCODED BY perUnaligned WITH UserEquipment-IEs-ECN-Module
    
```

```
RadioBearer-IEs ENCODED BY perUnaligned WITH RadioBearer-IEs-ECN-Module
TransportChannel-IEs ENCODED BY perUnaligned WITH TransportChannel-IEs-ECN-Module
PhysicalChannel-IEs ENCODED BY perUnaligned WITH PhysicalChannel-IEs-ECN-Module
Measurement-IEs ENCODED BY perUnaligned WITH Measurement-IEs-ECN-Module
Other-IEs ENCODED BY perUnaligned WITH Other-IEs-ECN-Module
ANSI-41-IEs ENCODED BY perUnaligned WITH ANSI-41-IEs-ECN-Module
```

END

12.3 ECN modules for RRC

```
Class-definitions-ECN-Module ENCODING-DEFINITIONS ::=
BEGIN
END
```

```
PDU-definitions-ECN-Module ENCODING-DEFINITIONS ::=
BEGIN
END
```

```
Corenetwork-IEs-ECN-Module ENCODING-DEFINITIONS ::=
BEGIN
END
```

```
UTRANMobility-IEs-ECN-Module ENCODING-DEFINITIONS ::=
BEGIN
END
```

```
UserEquipment-IEs-ECN-Module ENCODING-DEFINITIONS ::=
BEGIN
END
```

```
RadioBearer-IEs-ECN-Module ENCODING-DEFINITIONS ::=
BEGIN
END
```

```
TransportChannel-IEs-ECN-Module ENCODING-DEFINITIONS ::=
BEGIN
END
```

```
PhysicalChannel-IEs-ECN-Module ENCODING-DEFINITIONS ::=
BEGIN
END
```

```
Measurement-IEs-ECN-Module ENCODING-DEFINITIONS ::=
BEGIN
END
```

```
Other-IEs-ECN-Module ENCODING-DEFINITIONS ::=
BEGIN
END
```

```
ANSI-41-IEs-ECN-Module ENCODING-DEFINITIONS ::=
BEGIN
END
```

13 Protocol timers, counters and other parameters

The information provided in subclauses 13.1 and 13.2 shall be treated as informative. The normative text is specified in the relevant subclauses in clause 8 and clause 8 shall prevail.

13.1 Timers for UE

Timer	Start	Stop	At expiry
T300	Transmission of RRC CONNECTION REQUEST	Reception of RRC CONNECTION SETUP	Retransmit RRC CONNECTION REQUEST if V300 \leq N300, else go to Idle mode
T301	Transmission of RRC CONNECTION REESTABLISHMENT REQUEST	Reception of RRC CONNECTION REESTABLISHMENT	See subclause 8.1.5.8.
T302	Transmission of CELL UPDATE/ <u>URA UPDATE</u>	Reception of CELL UPDATE CONFIRM / <u>URA UPDATE CONFIRM</u>	Retransmit CELL UPDATE/ <u>URA UPDATE</u> if V302 \leq N302, else, go to Idle mode
T303	Transmission of URA UPDATE	Reception of URA UPDATE CONFIRM	Retransmit URA UPDATE if V303 \leq N303, else go to Idle mode
T304	Transmission of UE CAPABILITY INFORMATION	Reception of UE CAPABILITY INFORMATION CONFIRM	Retransmit UE CAPABILITY INFORMATION if V304 \leq N304, else initiate RRC connection reestablishment
T305	Entering CELL_FACH or URA_PCH or CELL_PCH state. Reception of CELL UPDATE CONFIRM/ <u>URA UPDATE CONFIRM</u> .	Entering another state.	Transmit CELL UPDATE / <u>URA UPDATE</u> if T307 is not activated.
T306	Entering URA_PCH state. Reception of URA UPDATE CONFIRM.	Entering another state.	Transmit URA UPDATE if T307 is not activated.
T307	When the timer T305 or T306 has expired and the UE detects "out of service area".	When the UE detects "in service area".	Transit to idle mode
T308	Transmission of RRC CONNECTION RELEASE COMPLETE	Not stopped	Transmit RRC CONNECTION RELEASE COMPLETE if V308 \leq N308, else go to idle mode.
T309	Upon reselection of a cell belonging to another radio access system from connected mode	Successful establishment of a connection in the new cell	Resume the connection to UTRAN
T310	Transmission of PUSCH CAPACITY REQUEST	Reception of PHYSICAL SHARED CHANNEL ALLOCATION	Transmit PUSCH CAPACITY REQUEST if V310 \leq N310, else procedure stops.
T311	Reception of PHYSICAL SHARED CHANNEL ALLOCATION message with the CHOICE "PUSCH allocation" set to "PUSCH allocation pending".	Reception of PHYSICAL SHARED CHANNEL ALLOCATION message with CHOICE "PUSCH allocation" set to "PUSCH allocation assignment".	UE may initiate a PUSCH capacity request procedure.
T312	When the UE starts to establish dedicated CH	When the UE detects consecutive N312 "in sync" indication from L1.	The criteria for physical channel establishment failure is fulfilled

Timer	Start	Stop	At expiry
T313	When the UE detects consecutive N313 "out of sync" indication from L1.	When the UE detects consecutive N315 "in sync" indication from L1.	The criteria for Radio Link failure is fulfilled
T314	When the criteria for radio link failure are fulfilled. The timer is started only if radio bearer(s) which are associated with T314 exist.	When the RRC Connection Re-establishment procedure has been completed.	See subclause 8.1.5.6
T315	When the criteria for radio link failure are fulfilled. The timer is started only if radio bearer(s) which are associated with T315 exist.	When the RRC Connection Re-establishment procedure has been completed.	See subclause 8.1.5.7
<u>T316</u>	<u>When the UE detects "out of service area" in URA_PCH or CELL_PCH state</u>	<u>When the UE detects "in service area".</u>	<u>Initiate cell update procedure</u>
<u>T317</u>	<u>When the T316 expires and the UE detects "out of service area".</u>	<u>When the UE detects "in service area".</u>	<u>Transit to idle mode</u>

13.2 Counters for UE

Counter	Reset	Incremented	When reaching max value
V300	When initiating the procedure RRC connection establishment	Upon expiry of T300.	When V300 > N300, the UE enters idle mode.
V301	When initiating the procedure RRC connection re-establishment	Upon expiry of T301.	When V301 > N301, the UE enters idle mode.
V302	When initiating the procedure Cell update or URA update	Upon expiry of T302	When V302 > N302 the UE enters idle mode.
<u>V303</u>	<u>When initiating the procedure URA update</u>	<u>Upon expiry of T303</u>	<u>When V302 > N303 the UE enters idle mode.</u>
V304	When sending the first UE CAPABILITY INFORMATION message.	Upon expiry of T304	When V304 > N304 the UE initiates the RRC connection re-establishment procedure
<u>V308</u>	<u>When sending the first RRC CONNECTION RELEASE COMPLETE message in a RRC connection release procedure.</u>	<u>Upon expiry of T308</u>	<u>When V308 > N308 the UE stops re-transmitting the RRC CONNECTION RELEASE COMPLETE message.</u>
<u>V310</u>	<u>When sending the first PUSCH CAPACITY REQUEST message in a PUSCH capacity request procedure</u>	<u>Upon expiry of T310</u>	<u>When V310 > N310 the UE stops re-transmitting the PUSCH CAPACITY REQUEST message.</u>

Counter	Reset	Decrement	When reaching zero
V308	When sending the first RRC CONNECTION RELEASE COMPLETE message in a RRC connection release procedure.	Upon expiry of T308	When V308 > N308 the UE stops retransmitting the RRC CONNECTION RELEASE COMPLETE message.

Counter	Reset	Incremented	When reaching max value
V310	When sending the first PUSCH CAPACITY REQUEST message in a PUSCH capacity request procedure	Upon expiry of T310	When V310 > N310 the UE stops retransmitting the PUSCH CAPACITY REQUEST message.

13.3 UE constants and parameters

Constant	Usage
N300	Maximum number of retransmissions of the RRC CONNECTION REQUEST message
N301	Maximum number of retransmissions of the RRC CONNECTION REESTABLISHMENT REQUEST message
N302	Maximum number of retransmissions of the CELL UPDATE / URA UPDATE message
N303	Maximum number of retransmissions of the URA UPDATE message
N304	Maximum number of retransmissions of the UE CAPABILITY INFORMATION message
N308	Maximum number of retransmissions of the RRC CONNECTION RELEASE COMPLETE message
N310	Maximum number of retransmission of the PUSCH CAPACITY REQUEST message
N312	Maximum number of successive "in sync" received from L1.
N313	Maximum number of successive "out of sync" received from L1.
N315	Maximum number of successive "in sync" received from L1 during T313 is activated.

13.4 UE variables

13.4.1 CIPHERING_STATUS

This variable contains information about the current status of ciphering in the UE.

Information Element/Group name	Need	Multi	Type and reference	Semantics description
Status	MP		Enumerated(Not started, Started)	

13.4.2 COMPRESSED_MODE_ERROR

This variable contains information on whether the received compressed mode configuration from the UTRAN has resulted in an illegal overlap causing a runtime error.

Information Element/Group name	Need	Multi	Type and reference	Semantics description
COMPRESSED_MODE_ERROR	MP		Boolean	

13.4.2a C RNTI

This variable stores the assigned C-RNTI for this UE when in CELL FACH state.

Information Element/Group name	Need	Multi	Type and reference	Semantics description
C-RNTI	OP		C-RNTI 10.3.3.8	

13.4.3 DEFAULT_TFC_SUBSET

This variable contains the TFC subset to go back to when a temporary TFC limitation is released.

Information Element/Group name	Need	Multi	Type and reference	Semantics description
TFC subset	MP		Transport Format Combination Subset 10.3.5.22	

13.4.4 DOFF

This variable contains the default offset value in the UE. See TS 25.402 for details.

Information Element/Group name	Need	Multi	Type and reference	Semantics description
Default DPCH Offset Value (DOFF)	OP		Default DPCH Offset Value, 10.3.6.15	

13.4.5 ESTABLISHED_RABS

This variable is used to store information about the established radio access bearers in the UE.

Information Element/Group name	Need	Multi	Type and reference	Semantics description
RAB information	OP	1 to <maxRABsetup>		For each RAB established
>RAB info	MP		RAB info 10.3.4.8	
>RB information	MP	1 to <maxRBperRAB>		For each RB belonging to the RAB
>>RB identity	MP		RB identity 10.3.4.16	
>>Subflow	MP		Integer(0..<maxSubflowcount>)	Reference to the RAB subflow implemented by this RB

13.4.5a ESTABLISHMENT CAUSE

This variable is used to store the cause for establishment of a signalling connection received by upper layers, to be used at RRC connection establishment.

<u>Information Element/Group name</u>	<u>Need</u>	<u>Multi</u>	<u>Type and reference</u>	<u>Semantics description</u>
<u>Establishment cause</u>	<u>OP</u>		<u>Establishment cause</u> 10.3.3.11	

13.4.5b FAILURE INDICATOR

This variable indicates whether the procedure has failed for a UE initiated procedure.

<u>Information Element/Group name</u>	<u>Need</u>	<u>Multi</u>	<u>Type and reference</u>	<u>Semantics description</u>
<u>Failure indicator</u>	<u>MP</u>		<u>Boolean</u>	<u>TRUE: Procedure has failed</u>

13.4.5c FAILURE CAUSE

This variable contains the cause for failure of a UE initiated procedure, to be reported in a retransmitted message.

<u>Information Element/Group name</u>	<u>Need</u>	<u>Multi</u>	<u>Type and reference</u>	<u>Semantics description</u>
<u>Failure cause</u>	<u>MP</u>		<u>Failure cause</u> 10.3.3.11a	

13.4.5d INITIAL UE IDENTITY

In this variable the identity used by the UE when establishing an RRC connection is stored.

<u>Information Element/Group name</u>	<u>Need</u>	<u>Multi</u>	<u>Type and reference</u>	<u>Semantics description</u>
<u>Initial UE identity</u>	<u>OP</u>		<u>Initial UE identity</u> 10.3.3.13	

13.4.5e INVALID CONFIGURATION

This variable indicates whether a received message contained an invalid configuration, by means of invalid values or invalid combinations of information elements.

<u>Information Element/Group name</u>	<u>Need</u>	<u>Multi</u>	<u>Type and reference</u>	<u>Semantics description</u>
<u>Invalid configuration</u>	<u>MP</u>		<u>Boolean</u>	<u>TRUE: An invalid configuration has been detected</u>

13.4.6 INTEGRITY_PROTECTION_INFO

This variable contains information about the current status of the integrity protection in the UE.

Information Element/Group name	Need	Multi	Type and reference	Semantics description
Status	MP		Enumerated(Not started, Started)	
Signalling radio bearer specific integrity protection information	MP	1 to <maxSRBsetup>		Status information for RB#0-4 in that order
> Uplink RRC HFN	MP		Bitstring (28)	
> Downlink RRC HFN	MP		Bitstring (28)	
> Uplink RRC Message sequence number	MP		Integer (0..15)	
> Downlink RRC Message sequence number	MP		Integer (0..15)	

13.4.7 MEASUREMENT_IDENTITY

This variable stores the measurements configured in the UE. For each configured measurement, the information below shall be stored.

Information Element/Group name	Need	Multi	Type and reference	Semantics description
MEASUREMENT CONTROL	MP		MEASUREMENT CONTROL 10.2.15	Information as contained in this message.

13.4.8 ORDERED_ASU

NOTE: For FDD only.

This variable stores information about an ordered, but not yet executed, update of active set.

Information Element/Group name	Need	Multi	Type and reference	Semantics description
ACTIVE SET UPDATE	MP		ACTIVE SET UPDATE 10.2.1	Information as contained in this message.

13.4.9 ORDERED_CONFIG

This variable stores information about an ordered but not yet executed establishment/release/reconfiguration of radio bearers, and/or transport channels and/or physical channels.

Information Element/Group name	Need	Multi	Type and reference	Semantics description
CHOICE message	MP			Information as contained in one of the following messages
>RADIO BEARER SETUP			RADIO BEARER SETUP 10.2.31	
>RADIO BEARER RECONFIGURATION			RADIO BEARER RECONFIGURATION 10.2.25	
>RADIO BEARER RELEASE			RADIO BEARER RELEASE 10.2.28	
>TRANSPORT CHANNEL RECONFIGURATION			TRANSPORT CHANNEL RECONFIGURATION 10.2.51	
>PHYSICAL CHANNEL RECONFIGURATION			PHYSICAL CHANNEL RECONFIGURATION 10.2.20	

13.4.10 PROTOCOL_ERROR_INDICATOR

This variable indicates whether there exist a protocol error that is to be reported to UTRAN.

Information Element/Group name	Need	Multi	Type and reference	Semantics description
Protocol error indicator	MP		Protocol error indicator 10.3.3.27	

13.4.11 PROTOCOL_ERROR_INFORMATION

This variable contains diagnostics to be reported to UTRAN for a message that was not completely understood.

Information Element/Group name	Need	Multi	Type and reference	Semantics description
Protocol error information	MP		Protocol error information 10.3.8.10	

13.4.12 PROTOCOL_ERROR_REJECT

This variable indicates whether there has occurred a severe protocol error causing the ongoing procedure to fail.

Information Element/Group name	Need	Multi	Type and reference	Semantics description
Protocol error reject	MP		Boolean	TRUE: a severe protocol error has occurred

13.4.13 RB_UPLINK_CIPHERING_ACTIVATION_TIME_INFO

This variable contains information to be sent to UTRAN about when a new ciphering configuration shall be activated in the uplink for radio bearers using RLC-AM or RLC-UM.

Information Element/Group name	Need	Multi	Type and reference	Semantics description
RB uplink ciphering activation time info	MP		RB activation time info 10.3.4.13	

13.4.14 SELECTED_PLMN

This variable contains the type of and identity of the selected PLMN.

Information Element/Group name	Need	Multi	Type and reference	Semantics description
PLMN Type	MP		PLMN Type 10.3.1.12	
CHOICE identity type	MP			
>PLMN identity			PLMN identity 10.3.1.11	
>SID			SID 10.3.9.11	

CHOICE identity type	Condition under which the given identity type is chosen
PLMN identity	PLMN Type is "GSM-MAP"
SID	PLMN Type is "ANSI-41"

13.4.14a START VALUE TO TRANSMIT

This variable contains the value of START for new radio bearer(s) to be transmitted in a response message.

Information Element/Group name	Need	Multi	Type and reference	Semantics description
START	OP		START 10.3.3.36	

13.4.15 TGPS_IDENTITY

This variable contains the configuration parameters of a compressed mode transmission gap pattern sequence

Information Element/Group name	Need	Multi	Type and reference	Semantics description
TGPS_IDENTITY	MP		DPCH compressed mode info 10.3.6.32	Information as contained in the IE group "Transmission gap pattern sequence configuration parameters".

13.4.15a TRANSACTIONS

This variable stores the identifications of the ongoing RRC procedure transactions.

<u>Information Element/Group name</u>	<u>Need</u>	<u>Multi</u>	<u>Type and reference</u>	<u>Semantics description</u>
<u>Accepted transactions</u>	<u>OP</u>	1 to <maxtrans actions>		Maximum one accepted transaction per downlink message type may be stored – each message type may appear only once in the list.
> <u>Message type</u>	<u>MP</u>		<u>Message Type</u>	
> <u>RRC transaction identifier</u>	<u>MP</u>		<u>RRC transaction identifier</u> 10.3.3.34a	
<u>Rejected transactions</u>	<u>OP</u>	1 to <maxtrans actions>		Maximum one rejected transaction per downlink message type may be stored – each message type may appear only once in the list.
> <u>Message type</u>	<u>MP</u>		<u>Message Type</u>	
> <u>RRC transaction identifier</u>	<u>MP</u>		<u>RRC transaction identifier</u> 10.3.3.34a	

13.4.16 UE_CAPABILITY_TRANSFERRED

This variable stores information about which UE capabilities that have been transferred to UTRAN.

<u>Information Element/Group name</u>	<u>Need</u>	<u>Multi</u>	<u>Type and reference</u>	<u>Semantics description</u>
UE radio access capability	OP		UE radio access capability 10.3.3.40	
UE system specific capability	OP		Inter-system message 10.3.8.6	Includes inter-system classmark

13.4.16a UNSUPPORTED_CONFIGURATION

This variable indicates whether a received message contained a configuration, that is not supported by the UE.

<u>Information Element/Group name</u>	<u>Need</u>	<u>Multi</u>	<u>Type and reference</u>	<u>Semantics description</u>
<u>Unsupported configuration</u>	<u>MP</u>		<u>Boolean</u>	TRUE: An unsupported configuration has been detected

13.4.16b URA_IDENTITY

This variable stores the assigned URA identity for this UE when in URA_PCH state.

<u>Information Element/Group name</u>	<u>Need</u>	<u>Multi</u>	<u>Type and reference</u>	<u>Semantics description</u>
<u>URA identity</u>	<u>OP</u>		<u>URA identity</u> 10.3.2.6	

13.4.16c U_RNTI

This variable stores the assigned U-RNTI for this UE.

<u>Information Element/Group name</u>	<u>Need</u>	<u>Multi</u>	<u>Type and reference</u>	<u>Semantics description</u>
<u>U-RNTI</u>	<u>MP</u>		<u>U-RNTI</u> <u>10.3.3.45</u>	

13.4.17 VALUE_TAG

This variable contains information about the value tag for the last received system information block of a given type, for all system information blocks using value tags.

Information Element/Group name	Need	Multi	Type and reference	Semantics description
MIB value tag	MP		MIB value tag 10.3.8.7	Value tag for the master information block
SIB 1 value tag	CV-GSM		PLMN value tag 10.3.8.8	Value tag for the system information block type 1
SIB 2 value tag	MP		PLMN value tag 10.3.8.8	Value tag for the system information block type 2
SIB 3 value tag	MP		Cell value tag 10.3.8.4	Value tag for the system information block type 3
SIB 4 value tag	MP		Cell value tag 10.3.8.4	Value tag for the system information block type 4
SIB 5 value tag	MP		Cell value tag 10.3.8.4	Value tag for the system information block type 5
SIB 6 value tag	MP		Cell value tag 10.3.8.4	Value tag for the system information block type 6
CHOICE mode				
>FDD				
>>SIB 8 value tag	MP		Cell value tag 10.3.8.4	Value tag for the system information block type 8
>TDD				(no data)
SIB 11 value tag	MP		Cell value tag 10.3.8.4	Value tag for the system information block type 11
SIB 12 value tag	MP		Cell value tag 10.3.8.4	Value tag for the system information block type 12
SIB 13 value tag	CV-ANSI		Cell value tag 10.3.8.4	Value tag for the system information block type 13
SIB 13.1 value tag	CV-ANSI		Cell value tag 10.3.8.4	Value tag for the system information block type 13.1
SIB 13.2 value tag	CV-ANSI		Cell value tag 10.3.8.4	Value tag for the system information block type 13.2
SIB 13.3 value tag	CV-ANSI		Cell value tag 10.3.8.4	Value tag for the system information block type 13.3
SIB 13.4 value tag	CV-ANSI		Cell value tag 10.3.8.4	Value tag for the system information block type 13.4
CHOICE mode				
>TDD				
>>SIB 14 value tag	MP		Cell value tag 10.3.8.4	Value tag for the system information block type 14
>FDD				(no data)
SIB 15 value tag	MP		Cell value tag 10.3.8.4	Value tag for the system information block type 15
SIB 15.1 value tag	MP		Cell value tag 10.3.8.4	Value tag for the system information block type 15.1
SIB 15.2 value tag	MP		Cell value tag 10.3.8.4	Value tag for the system information block type 15.2
SIB 15.3 value tag	MP		Cell value tag 10.3.8.4	Value tag for the system information block type 15.3
SIB 16 value tag	MP		PLMN value tag 10.3.8.8	Value tag for the system information block type 16

Condition	Explanation
GSM	This information is only stored when the PLMN Type in the variable SELECTED_PLMN is "GSM-MAP".
ANSI	This information is only stored when the PLMN Type in the variable SELECTED_PLMN is "ANSI-41".

14 Specific functions

14.1 Intra-frequency measurements

14.1.1 Intra-frequency measurement quantities

- 1 Downlink E_c/I_0 (chip energy per total received channel power density).
- 2 Downlink path loss.
- 3 Downlink received signal code power (RSCP) after despreading.
- 4 ISCP measured on Timeslot basis.

14.1.2 Intra-frequency reporting events for FDD

Within the measurement reporting criteria field in the Measurement Control message the UTRAN notifies the UE which events should trigger a measurement report. Examples of intra-frequency reporting events that would be useful for intra-frequency handover evaluation are given below. Note that normally the UEs do not need to report all these events. The listed events are the toolbox from which the UTRAN can choose the reporting events that are needed for the implemented handover evaluation function, or other radio network functions.

All the illustrated events are measured with respect to any of the measurement quantities given in subclause 14.1.1. The measurement objects are the monitored primary common pilot channels (CPICH). The reporting events are marked with vertical arrows in the figures below.

NOTE: The events below are numbered 1A, 1B, 1C,... since all intra-frequency reporting events would be labelled 1X, inter-frequency reporting events would be labelled 2X, and so on for the other measurement types.

14.1.2.1 Reporting event 1A: A Primary CPICH enters the reporting range

When event 1A is ordered by UTRAN in a measurement control message, the UE shall send a measurement report when a primary CPICH enters the reporting range as defined by the following formula:

For pathloss:

$$10 \cdot \text{Log}M_{\text{New}} \geq W \cdot 10 \cdot \text{Log} \left(\sum_{i=1}^{N_A} M_i \right) + (1 - W) \cdot 10 \cdot \text{Log}M_{\text{Best}} + (R + H_{1a}),$$

For all the other measurement quantity:

$$10 \cdot \text{Log}M_{\text{New}} \geq W \cdot 10 \cdot \text{Log} \left(\sum_{i=1}^{N_A} M_i \right) + (1 - W) \cdot 10 \cdot \text{Log}M_{\text{Best}} - (R + H_{1a}),$$

The variables in the formula are defined as follows:

M_{New} is the measurement result of the cell entering the reporting range.

M_i is a measurement result of a cell in the active set.

N_A is the number of cells in the current active set.

M_{Best} is the measurement result of the strongest cell in the active set.

W is a parameter sent from UTRAN to UE.

R is the reporting range

H_{1a} is the hysteresis parameter for the event 1a.

The addition window of cells in event 1A is configured with the reporting range parameter (R) common to many reporting events and an optional hysteresis parameter (H1a), which can be used to distinguish the addition window from reporting windows related to other measurement events.

The occurrence of event 1A is conditional on a report deactivation threshold parameter. This parameter indicates the maximum number of cells allowed in the active set for measurement reports to be triggered by event 1A to be transmitted.

Event 1A may be enhanced with an addition timer, which is configured with the time-to-trigger parameter (see subclause 14.1.5.2). If a time-to-trigger value is used, a cell must continuously stay within the reporting range for the given time period, before the UE shall send a measurement report.

Event 1A may be used for triggering a measurement report, which includes unlisted cells, which the UE has detected.

14.1.2.2 Reporting event 1B: A primary CPICH leaves the reporting range

When this event is ordered by UTRAN in a measurement control message, the UE shall send a measurement report when a primary CPICH leaves the reporting range as defined by the following formula:

For pathloss:

$$10 \cdot \text{Log}M_{New} \leq W \cdot 10 \cdot \text{Log} \left(\sum_{i=1}^{N_A} M_i \right) + (1-W) \cdot 10 \cdot \text{Log}M_{Best} + (R + H_{1a}),$$

For all the other measurement quantity:

$$10 \cdot \text{Log}M_{Old} \leq W \cdot 10 \cdot \text{Log} \left(\sum_{i=1}^{N_A} M_i \right) + (1-W) \cdot 10 \cdot \text{Log}M_{Best} - (R + H_{1b}),$$

The variables in the formula are defined as follows:

M_{Old} is the measurement result of the cell leaving the reporting range.

M_i is a measurement result of a cell in the active set.

N_A is the number of cells in the current active set.

M_{Best} is the measurement result of the strongest cell in the active set.

W is a parameter sent from UTRAN to UE.

R is the reporting range

H_{1b} is the hysteresis parameter for the event 1b.

The drop window of cells in event 1B is configured with the reporting range parameter (R) common to many reporting events and an optional hysteresis parameter (H1b), which can be used to distinguish the drop window from reporting windows related to other measurement events.

Event 1B may be enhanced with a drop timer, which is configured with the time-to-trigger parameter. If the timer is used, the weakening cell must continuously stay below the reporting range for the given time period before the UE may send a measurement report.

14.1.2.3 Reporting event 1C: A non-active primary CPICH becomes better than an active primary CPICH

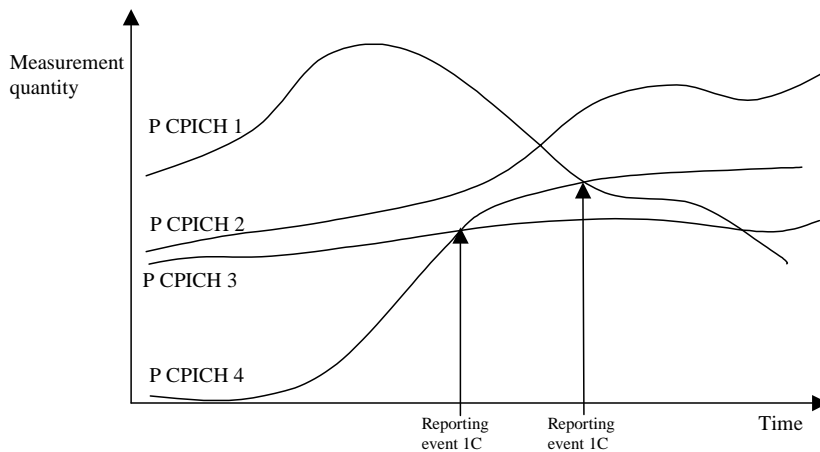

Figure 64: A primary CPICH that is not included in the active set becomes better than a primary CPICH that is in the active set

In this example the cells belonging to primary CPICH 1, 2 and 3 are supposed to be in the active set, but the cell transmitting primary CPICH 4 is not (yet) in the active set.

If a primary CPICH that is not included in the active set becomes better than a primary CPICH that is in the active set, and event 1C has been ordered by UTRAN, this event shall trigger a report to be sent from the UE.

This event may be used for replacing cells in the active set. It is activated if the number of active cells is equal to or greater than a replacement activation threshold parameter that UTRAN signals to the UE in the MEASUREMENT CONTROL message. This parameter indicates the minimum number of cells required in the active set for measurement reports triggered by event 1C to be transmitted.

14.1.2.4 Reporting event 1D: Change of best cell

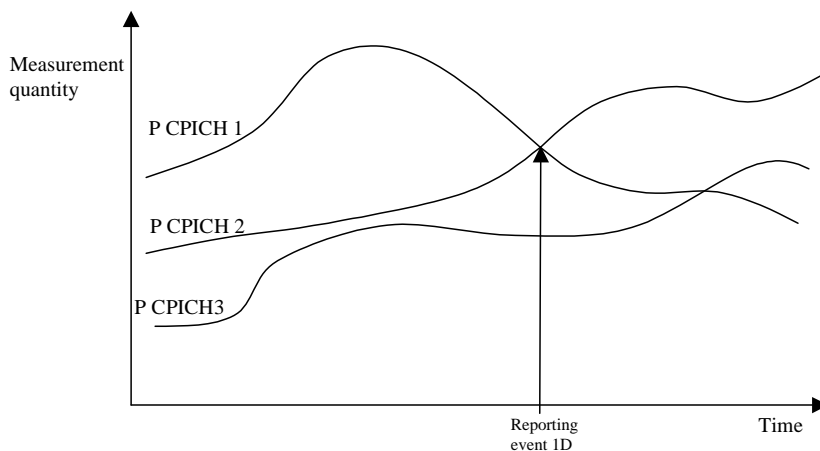

Figure 65: A primary CPICH becomes better than the previously best primary CPICH

If any of the primary CPICHs within the reporting range becomes better than the previously best primary CPICH, and event 1D has been ordered by UTRAN then this event shall trigger a report to be sent from the UE. The corresponding report contains (at least) the new best primary CPICH.

14.1.2.5 Reporting event 1E: A Primary CPICH becomes better than an absolute threshold

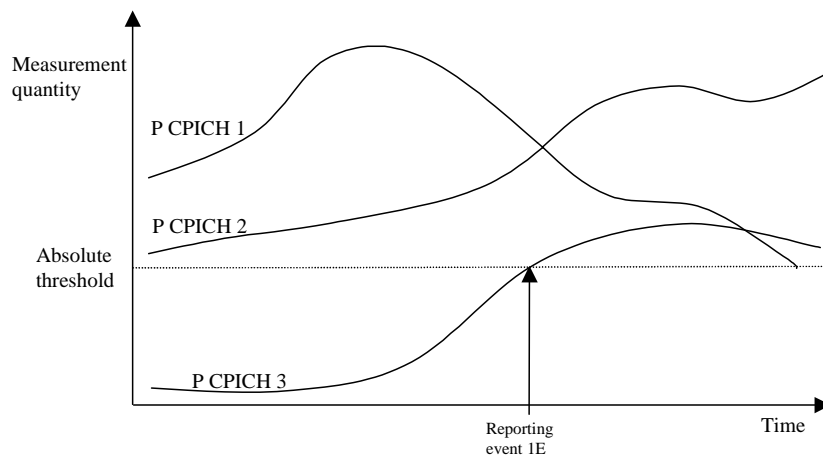

Figure 66: Event-triggered report when a Primary CPICH becomes better than an absolute threshold

When this event is ordered by UTRAN in a measurement control message the UE shall send a report when the Measurement quantity of a Primary CPICH becomes better than an absolute threshold. The corresponding report contains (at least) the involved Primary CPICH.

Event 1E may be used for triggering a measurement report, which includes unlisted cells, which the UE has detected.

14.1.2.6 Reporting event 1F: A Primary CPICH becomes worse than an absolute threshold

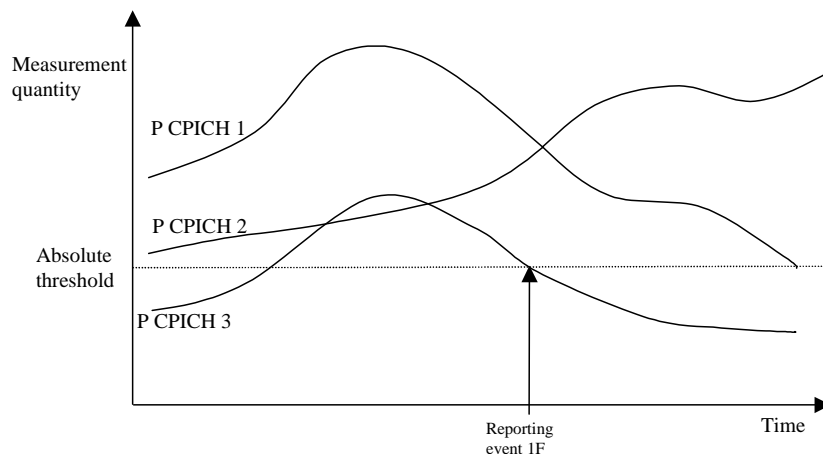

Figure 67: Event-triggered report when a Primary CPICH becomes worse than an absolute threshold

When this event is ordered by the UTRAN in a measurement control message the UE shall send a report when a primary CPICH becomes worse than an absolute threshold. The corresponding report contains (at least) the involved Primary CPICH.

14.1.3 Intra-frequency reporting events for TDD

14.1.3.1 Reporting event 1G: Change of best cell (TDD)

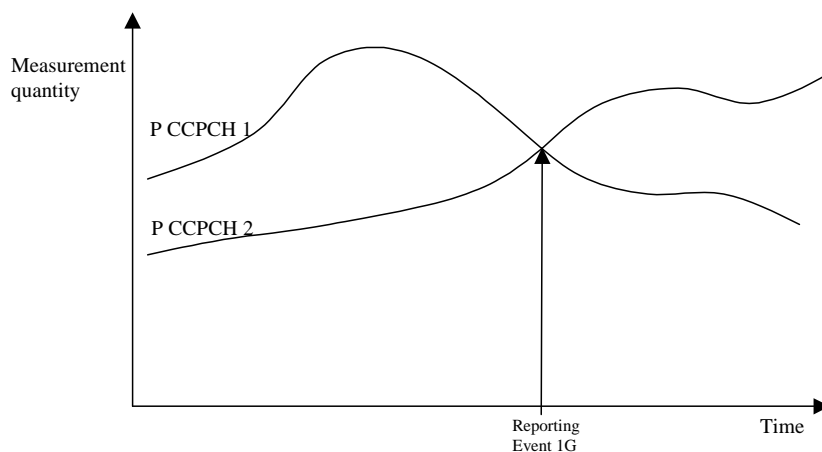

Figure 68: A primary CCPCH becomes better than the previous best primary CCPCH

If any of the primary CCPCHs becomes better than the previously best primary CCPCH, and event 1G has been ordered by UTRAN then this event shall trigger a report to be sent from the UE. The corresponding report contains (at least) the new best primary CCPCH.

14.1.3.2 Reporting event 1H: Timeslot ISCP below a certain threshold (TDD)

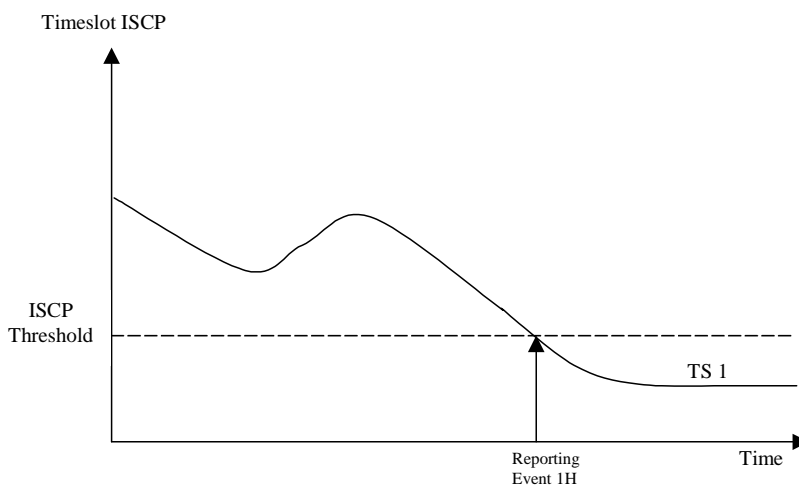

Figure 69: An ISCP value of a timeslot drops below an absolute threshold

When this event is ordered by UTRAN in a measurement control message the UE shall send a report when the Timeslot ISCP drops below an absolute threshold.

14.1.3.3 Reporting event 1I: Timeslot ISCP above a certain threshold (TDD)

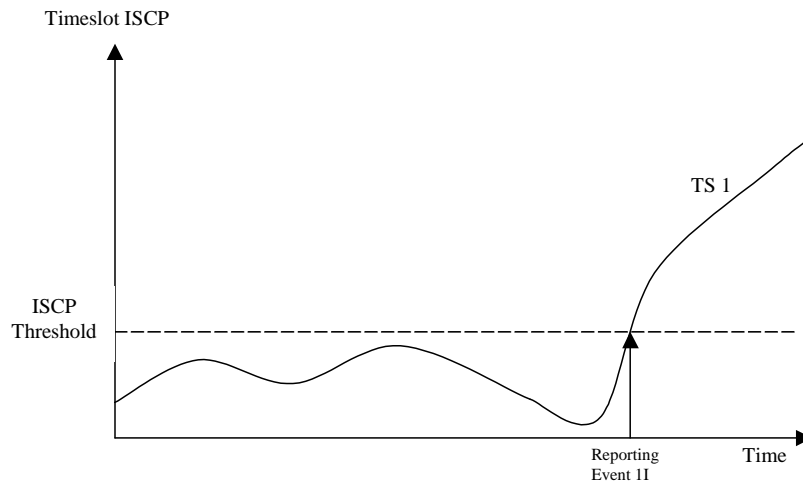

Figure 70: An ISCP value of a timeslot exceeds a certain threshold

When this event is ordered by UTRAN in a measurement control message the UE shall send a report when the Timeslot ISCP exceeds an absolute threshold.

14.1.4 Event-triggered periodic intra-frequency measurement reports

14.1.4.1 Cell addition failure (FDD only)

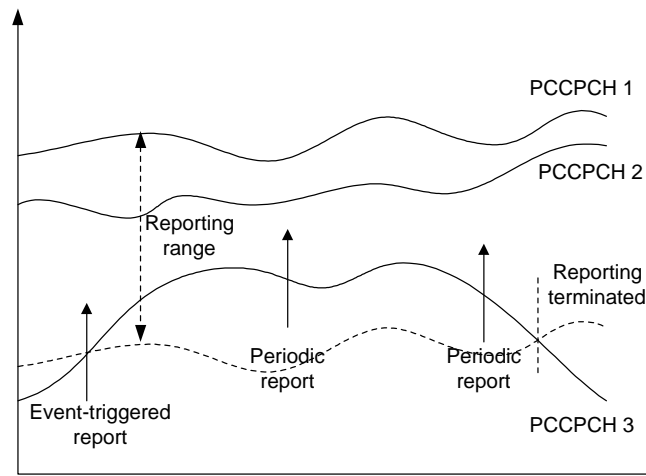

Figure 71: Periodic reporting triggered by event 1A

When a cell enters the reporting range and triggers event 1A, the UE shall transmit a MEASUREMENT REPORT to the UTRAN and typically this may result in an update of the active set. However, in some situations the UTRAN may be unable to add a strong cell to the active set typically due to capacity shortage for example.

The UE shall continue reporting after the initial report by reverting to periodical measurement reporting if the reported cell is not added to the active set. This is illustrated in Figure 71. During periodic reporting the UE shall transmit MEASUREMENT REPORT messages to the UTRAN at predefined intervals. The reports shall include reporting information of the cells in the current active set and of the monitored cell(s) in the reporting range.

Event-triggered periodic measurement reporting shall be terminated either when there are no longer any monitored cell(s) within the reporting range or when the UTRAN has added cells to the active set so that it includes the maximum

number of cells (defined by the reporting deactivation threshold parameter), which are allowed for event 1A to be triggered.

The reporting period is assigned by the UTRAN. If the reporting period is set to zero event-triggered measurement reporting shall not be applied.

NOTE: The figure should be updated to reflect that the measurements are made on the CPICH rather than PCCPCH.

14.1.4.2 Cell replacement failure (FDD only)

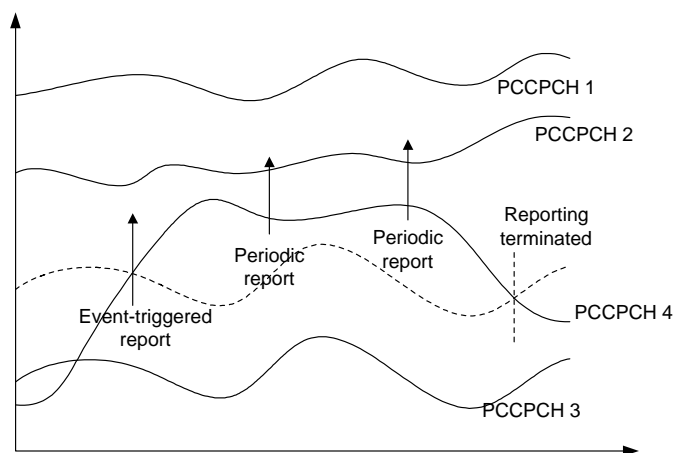

Figure 72: Periodic reporting triggered by event 1C

When a cell enters the replacement range and triggers event 1C, the UE shall transmit a MEASUREMENT REPORT to the UTRAN and typically this may result in the replacement of the weakest active cell. If the UTRAN is unable to replace the cell due to for example capacity shortage, it is beneficial to receive continuous reports in this case as well.

The UE shall revert to periodical measurement reporting if the UTRAN does not update the active set after the transmission of the measurement report. This is illustrated in Figure 72. During periodic reporting the UE shall transmit MEASUREMENT REPORT messages to the UTRAN at predefined intervals. The reports shall include reporting information of the cells in the current active set and of the monitored cell(s) in the replacement range.

Event-triggered periodic measurement reporting shall be terminated either when there are no longer any monitored cell(s) within the replacement range or when the UTRAN has removed cells from the active set so that there are no longer the minimum amount of active cells for event 1C to be triggered (as defined by the replacement activation threshold parameter).

The reporting period is assigned by the UTRAN. If the reporting period is set to zero, event-triggered measurement reporting shall not be applied.

NOTE: The figure should be updated to reflect that the measurements are made on the CPICH rather than PCCPCH.

14.1.5 Mechanisms available for modifying intra-frequency measurement reporting behaviour

14.1.5.1 Hysteresis

To limit the amount of event-triggered reports, a hysteresis parameter may be connected with each reporting event given above. The value of the hysteresis is given to the UE in the Reporting criteria field of the Measurement Control message.

In the example in Figure 73, the hysteresis ensures that the event 1D (FDD) or IG(TDD) (primary CPICH(FDD)/CCPCH(TDD) 2 becomes the best cell) is not reported until the difference is equal to the hysteresis value. The fact that primary CPICH(FDD)/CCPCH(TDD) 1 becomes best afterwards is not reported at all in the

example since the primary CPICH(FDD)/CCPCH(TDD) 1 does not become sufficiently better than the primary CPICH(FDD)/CCPCH(TDD) 2.

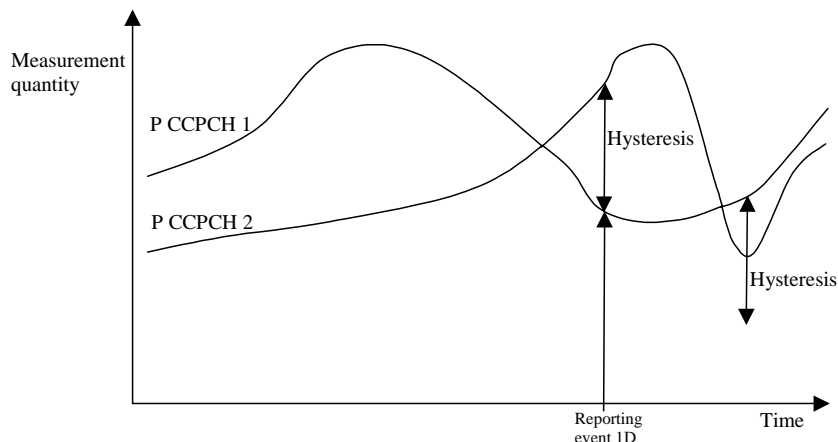

Figure 73: Hysteresis limits the amount of measurement reports

14.1.5.2 Time-to-trigger

To limit the measurement signalling load, a time-to-trigger parameter could be connected with each reporting event given above. The value of the time-to-trigger is given to the UE in the Reporting criteria field of the Measurement Control message.

The effect of the time-to-trigger is that the report is triggered only after the conditions for the event have existed for the specified time-to-trigger. In the following FDD example in Figure 74, the use of time-to-trigger means that the event (primary CPICH 3 enters the reporting range) is not reported until it has been within the range for the time given by the time-to-trigger parameter.

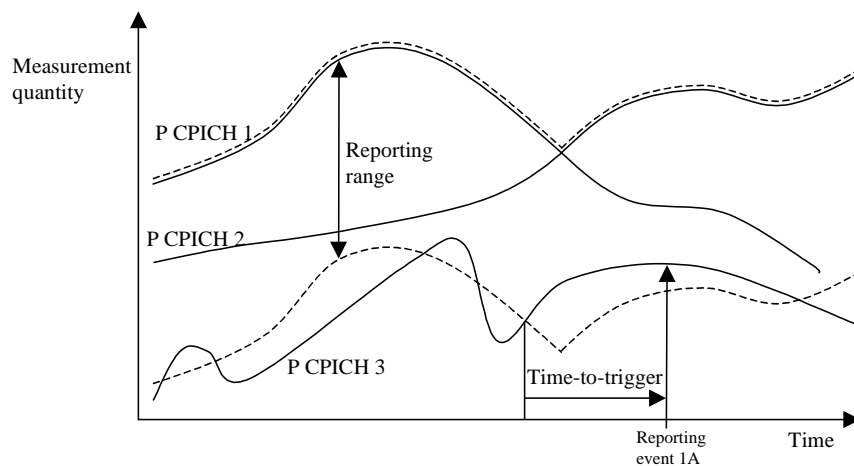

Figure 74: Time-to-trigger limits the amount of measurement reports

In the following TDD example in Figure 75, the use of time-to-trigger means that the event (Timeslot ISCP upon certain threshold) is not reported until it has been upon the threshold for the time given by the time-to-trigger parameter.

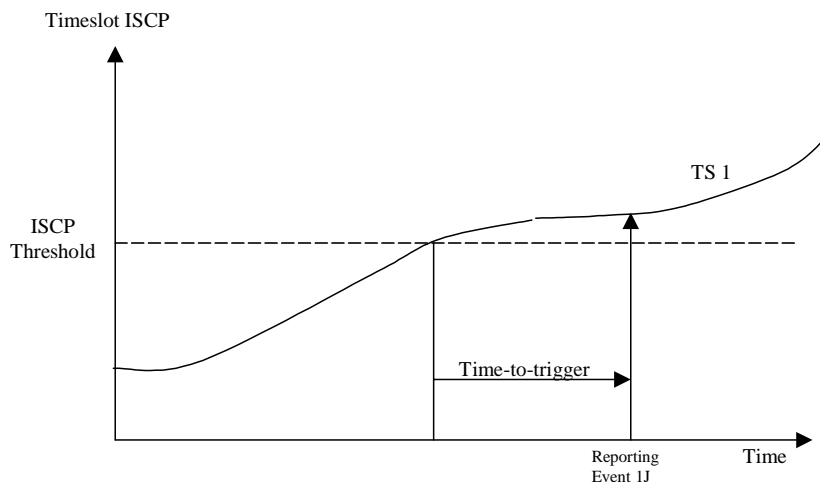

Figure 75: Time-to-trigger limits the amount of measurement reports

Note that the time-to-trigger could be combined with hysteresis, i.e. a hysteresis value is added to the measurement quantity before evaluating if the time-to-trigger timer should be started.

14.1.5.3 Cell individual offsets

For each cell that is monitored, an offset can be assigned with inband signalling. The offset can be either positive or negative. The offset is added to the measurement quantity before the UE evaluates if an event has occurred. The UE receives the cell individual offsets for each primary CPICH(FDD)/CCPCH(TDD) in the measurement object field of the MEASUREMENT CONTROL message.

For the FDD example, in Figure 76, since an offset is added to primary CPICH 3, it is the dotted curve that is used to evaluate if an event occurs. Hence, this means that measurement reports from UE to UTRAN are triggered when primary CPICH plus the corresponding offset, i.e. the dotted curve, leaves and enters the reporting range and when it gets better than primary CPICH 1 (if these events have been ordered by UTRAN). This offset mechanism provides the network with an efficient tool to change the reporting of an individual primary CPICH.

By applying a positive offset, as in Figure 76, the UE will send measurement reports as if the primary CPICH is offset x dB better than what it really is. This could be useful if the operator knows that a specific cell is interesting to monitor more carefully, even though it is not so good for the moment. In the example in Figure 76, the operator might know by experience that in this area primary CPICH 3 can become good very quickly (e.g. due to street corners) and therefore that it is worth reporting more intensively. Depending on the implemented handover evaluation algorithm, this may result in the cell with primary CPICH 3 being included in the active set earlier than would have been the case without the positive offset.

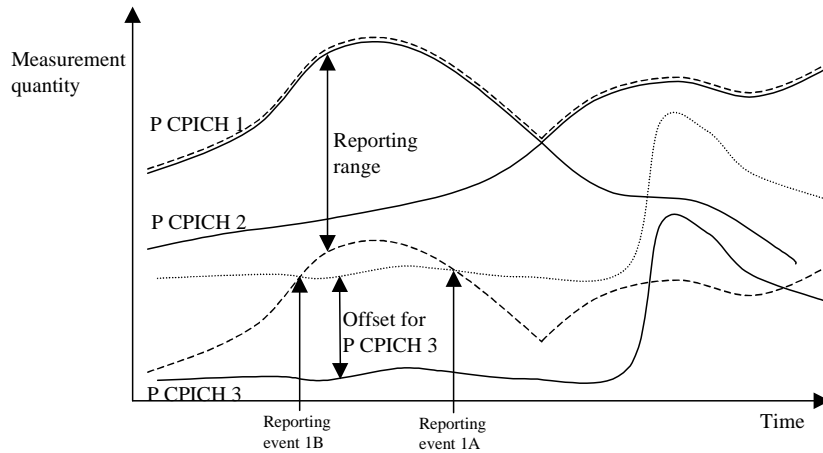

Figure 76: A positive offset is applied to primary CPICH 3 before event evaluation in the UE

For the TDD example, in Figure 77, an offset is added to primary CCPCH2, it is the dotted curve that is used to evaluate if the primary CCPCH2 becomes better than primary CCPCH1 (ordered by the UTRAN).

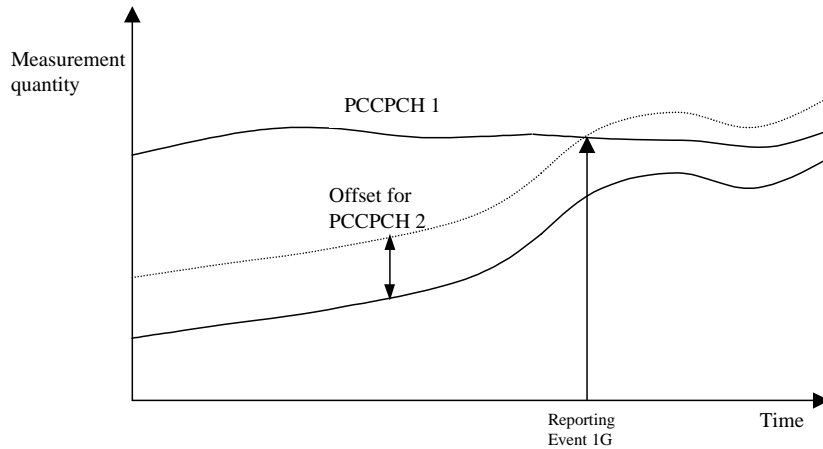

Figure 77: A positive offset is applied to primary CCPCH 2

Correspondingly, the operator can choose to apply a negative offset to a primary CCPCH. Then the reporting on that primary CCPCH is limited and the corresponding cell may be, at least temporarily excluded from the active set or as a target cell for handover.

The cell individual offset can be seen as a tool to move the cell border. It is important to note that the offset is added before triggering events, i.e. the offset is added by the UE before evaluating if a measurement report should be sent as opposed to offsets that are applied in the network and used for the actual handover evaluation.

14.1.5.4 Forbid a Primary CPICH to affect the reporting range (FDD only)

The reporting range affects the reporting events 1A and 1B presented above. The reporting range is defined as a function of all the Primary CPICHs in the active set (see 14.1.2.1 and 14.1.2.2). If the parameter W is set to 0, the reporting range is defined relative to the best Primary CPICH. However, there could be cases where it is good to forbid a specific Primary CPICH to affect the reporting range. For example in Figure 78 the network has requested the UE to not let Primary CPICH 3 affect the reporting range. This mechanism could be effective if the operator knows by experience that the quality of Primary CPICH 3 is very unstable in a specific area and therefore should not affect the reporting of the other Primary CPICHs.

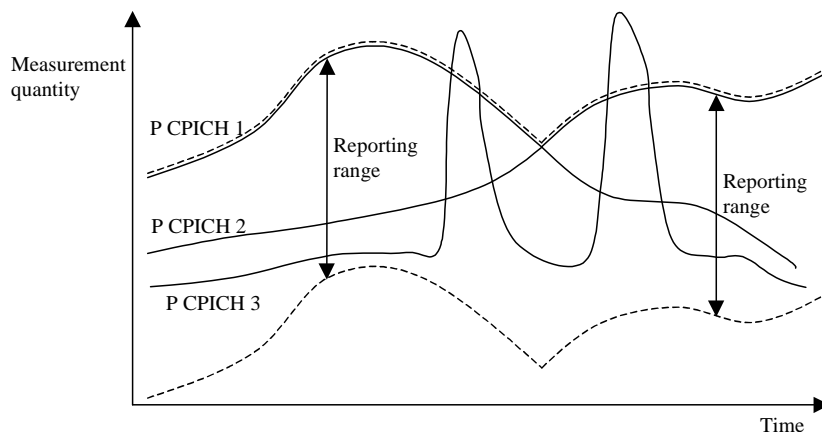

Figure 78: Primary CPICH 3 is forbidden to affect the reporting range

14.1.6 Report quantities

In the event-triggered measurement reports, mandatory information connected to the events is always reported. For instance, at the event "a primary CPICH(FDD)/CCPCH(TDD) enters the reporting range" the corresponding report identifies the primary CPICH(FDD)/CCPCH(TDD) that entered the range.

However, besides this mandatory information, UTRAN should be able to optionally require additional measurement information in the report to support the radio network functions in UTRAN. Furthermore, it will allow the UTRAN to use the UE as a general tool for radio network optimization if necessary.

Examples of report quantities that may be appended to the measurement reports are:

NOTE: This list is general and does also apply for reports of other measurement types than the intra-frequency type. The list is not final.

- Downlink transport channel block error rate.
- Downlink transport channel bit error rate.
- Downlink E_c/I_0 on primary CPICH(FDD)/CCPCH(TDD) (e.g. used for initial DL power setting on new radio links).
- Time difference between the received primary CPICH(FDD)/CCPCH(TDD) frame-timing from the target cell and the earliest received existing DPCH path. [Note: This measurement is identified in 25.211 [2] (denoted T_m in clause 7)].
- UE transmit power.
- UE position (FFS).
- Downlink SIR (RSCP/ISCP) on the traffic channels after RAKE combining (FFS).

14.2 Inter-frequency measurements

The frequency quality estimate used in events 2a, 2b 2c, 2d and 2e is defined as:

$$Q_{carrier j} = 10 \cdot \text{Log} M_{carrier j} = W_j \cdot 10 \cdot \text{Log} \left(\sum_{i=1}^{N_{A_j}} M_{i j} \right) + (1 - W_j) \cdot 10 \cdot \text{Log} M_{Best j} - H,$$

The variables in the formula are defined as follows:

Q_j is the estimated quality of the active set on frequency j

M_j is the estimated quality of the active set on frequency j .

$M_{i,j}$ is a measurement result of cell i in the active set on frequency j .

N_A is the number of cells in the active set on frequency j .

$M_{Best,j}$ is the measurement result of the strongest cell in the active set on frequency j

W_j is a parameter sent from UTRAN to UE and used for frequency j

H is the hysteresis parameter

14.2.1 Inter-frequency reporting events

Within the measurement reporting criteria field in the MEASUREMENT CONTROL message UTRAN notifies the UE which events should trigger the UE to send a MEASUREMENT REPORT message. Examples of inter-frequency reporting events that would be useful for inter-frequency handover evaluation are given below. Note that normally the UEs do not need to report all these events. The listed events are the toolbox from which the UTRAN can choose the reporting events that are needed for the implemented handover evaluation function, or other radio network functions.

All events are evaluated with respect to one of the measurement quantities given in subclause 14.x.x. The measurement objects are the monitored primary common pilot channels (CPICH) in FDD mode and the monitored primary common control channels (PCCPCH) in TDD mode. A "non-used frequency" is a frequency that the UE have been ordered to measure upon but are not used of the active set. A "used frequency" is a frequency that the UE have been ordered to measure upon and is also currently used for the connection.

14.2.1.1 Event 2a: Change of best frequency.

If any of the non- used frequencies quality estimate becomes better than the currently used frequency quality estimate, and event 2a has been ordered by UTRAN then this event shall trigger a report to be sent from the UE when the hysteresis and time to trigger conditions is fulfilled. The corresponding report contains (at least) the best primary CPICH (FDD) or primary CCPCH (TDD) on the non-used frequency that triggered the event.

14.2.1.2 Event 2b: The estimated quality of the currently used frequency is below a certain threshold and the estimated quality of a non-used frequency is above a certain threshold.

When this event is ordered by UTRAN in a MEASUREMENT CONTROL message the UE shall send a report when the estimated quality of the currently used frequency is below the value of the IE "Threshold used frequency" and the estimated quality of a non-used frequency is above the value of the IE "Threshold non-used frequency" and the hysteresis and time to trigger conditions are fulfilled. The corresponding report contains at least the best primary CPICH (FDD) or primary CCPCH (TDD) on the non-used frequency that triggered the event.

14.2.1.3 Event 2c: The estimated quality of a non-used frequency is above a certain threshold

When this event is ordered by UTRAN in a MEASUREMENT CONTROL message the UE shall send a report when the estimated quality of a non-used frequency is above the value of the IE "Threshold non-used frequency" and the hysteresis and time to trigger conditions are fulfilled. The corresponding report contains at least the best primary CPICH (FDD) or primary CCPCH (TDD) on the non-used frequency.

14.2.1.4 Event 2d: The estimated quality of the currently used frequency is below a certain threshold

When this event is ordered by UTRAN in a MEASUREMENT CONTROL message the UE shall send a report when the estimated quality of the currently used frequency is below the value of the IE "Threshold used frequency" and the hysteresis and time to trigger conditions are fulfilled. The corresponding report contains at least the best primary CPICH (FDD) or primary CCPCH (TDD) on the used frequency.

14.2.1.5 Event 2e: The estimated quality of a non-used frequency is below a certain threshold

When this event is ordered by UTRAN in a MEASUREMENT CONTROL message the UE shall send a report when the estimated quality of a non-used frequency is below the value of the IE "Threshold non-used frequency" and the hysteresis and time to trigger conditions are fulfilled. The corresponding report contains at least the best primary CPICH (FDD) or primary CCPCH (TDD) on the non-used frequency.

14.2.1.6 Event 2 f: The estimated quality of the currently used frequency is above a certain threshold

When this event is ordered by UTRAN in a MEASUREMENT CONTROL message the UE shall send a report when the estimated quality of the currently used frequency is above the value of the IE "Threshold used frequency" and the hysteresis and time to trigger conditions are fulfilled. The corresponding report contains at least the best primary CPICH (FDD) or primary CCPCH (TDD) on the used frequency.

14.3 Inter-system measurements

The estimated quality of the active set in UTRAN in events 3a is defined as:

$$Q_{UTRAN} = 10 \cdot \text{Log}M_{UTRAN} = W \cdot 10 \cdot \text{Log} \left(\sum_{i=1}^{N_A} M_i \right) + (1 - W) \cdot 10 \cdot \text{Log}M_{Best}$$

The variables in the formula are defined as follows:

Q_{UTRAN} is the estimated quality of the active set on the currently used UTRAN frequency

M_{UTRAN} is the estimated quality of the active set on currently used UTRAN frequency expressed in another unit.

M_i is a measurement result of cell i in the active set.

N_A is the number of cells in the active set.

M_{Best} is the measurement result of the strongest cell in the active set.

W is a parameter sent from UTRAN to UE.

14.3.1 Inter-System reporting events

Within the measurement reporting criteria field in the MEASUREMENT CONTROL message the UTRAN notifies the UE which events should trigger the UE to send a MEASUREMENT REPORT message. Examples of inter-system reporting events that would be useful for inter-system handover evaluation are given below. Note that normally the UEs do not need to report all these events. The listed events are the toolbox from which the UTRAN can choose the reporting events that are needed for the implemented handover evaluation function, or other radio network functions.

All events are measured with respect to one of the measurement quantities given in subclause 14.x.x. The measurement objects are the monitored primary common pilot channels (CPICH) in FDD mode and the monitored primary common control channels (PCCPCH) in TDD mode for UTRAN and objects specific for other systems. A "used UTRAN frequency" is a frequency that the UE have been ordered to measure upon and is also currently used for the connection to UTRAN. "Other system" is e.g. GSM.

14.3.1.1 Event 3a: The estimated quality of the currently used UTRAN frequency is below a certain threshold and the estimated quality of the other system is above a certain threshold.

When this event is ordered by UTRAN in a MEASUREMENT CONTROL message the UE shall send a report when the estimated quality of the currently used frequency is below the value of the IE "Threshold own system" and the hysteresis and time to trigger conditions are fulfilled and the estimated quality of the other system is above the value of the IE "Threshold other system" and the hysteresis and time to trigger conditions are fulfilled. The corresponding report

contains information specific for the other system and the best primary CPICH (FDD) or primary CCPCH (TDD) on the used frequency.

14.3.1.2 Event 3b: The estimated quality of other system is below a certain threshold

When this event is ordered by UTRAN in a measurement control message the UE shall send a report when the estimated quality of the other system is below the value of the IE " Threshold other system" and the hysteresis and time to trigger conditions are fulfilled. The corresponding report contains information specific for the other system and the best primary CPICH (FDD) or primary CCPCH (TDD) on the non-used frequency.

14.3.1.3 Event 3c: The estimated quality of other system is above a certain threshold

When this event is ordered by UTRAN in a measurement control message the UE shall send a report when the estimated quality of the other system is above the value of the IE " Threshold other system" and the hysteresis and time to trigger conditions are fulfilled. The corresponding report contains information specific for the other system and the best primary CPICH (FDD) or primary CCPCH (TDD) on the non-used frequency.

14.3.1.4 Event 3d: Change of best cell in other system

If any of the quality estimates for the cells in the other system becomes better than the quality estimate for the currently best cell in the other system, and event 3d has been ordered by UTRAN then this event shall trigger a report to be sent from the UE when the hysteresis and time to trigger conditions is fulfilled. The corresponding report contains (at least) information the best cell in the other system.

14.4 Traffic Volume Measurements

14.4.1 Traffic Volume Measurement Quantity

For traffic volume measurements in the UE only one quantity is measured. This quantity is RLC buffer payload in number of bytes. In order to support a large variation of bit rates and RLC buffer size capabilities, a non-linear scale should be used [NOTE: details are FFS]. Since, the expected traffic includes both new and retransmitted RLC payload units all these should be included in the payload measure. It should also be noted that traffic volume measurements are only applicable for acknowledged and unacknowledged mode.

According to what is stated in the Measurement Control message, the UE should support measuring of buffer payload for a specific RB, RBs multiplexed onto the same Transport channel and the total UE buffer payload (the same as one transport channel for a UE that uses RACH).

14.4.2 Traffic Volume reporting events

Traffic volume can be reported in two different ways, periodical and event triggered. For periodical reporting the UE simply measures the number of bytes for the transport channel (i.e. the RLC buffers of the RBs multiplexed onto that transport channel) stated in the measurement control message and reports the traffic volume at the given time instants. Event triggered reporting is performed when a threshold is exceeded.

The reporting quantities that should be included in the report are stated in the measurement control message. This could for example be which RBs or RLC buffers to include when sending the payload to the network.

14.4.2.1 Reporting event 4 A: RLC buffer payload exceeds an absolute threshold

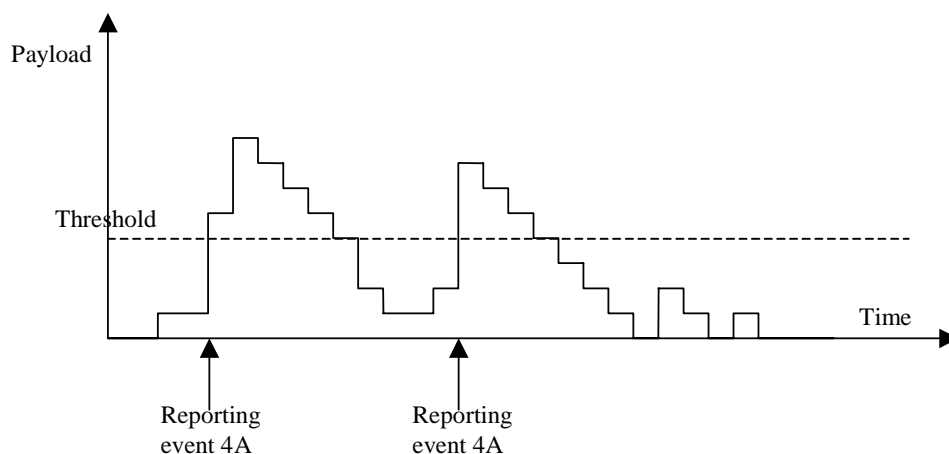

Figure 79: Event triggered report when RLC buffer payload exceeds a certain threshold

If the monitored payload exceeds an absolute threshold, this is an event that could trigger a report. The corresponding report contains at least which transport channel triggered the report.

14.4.2.2 Reporting event 4 B: RLC buffer payload becomes smaller than an absolute threshold

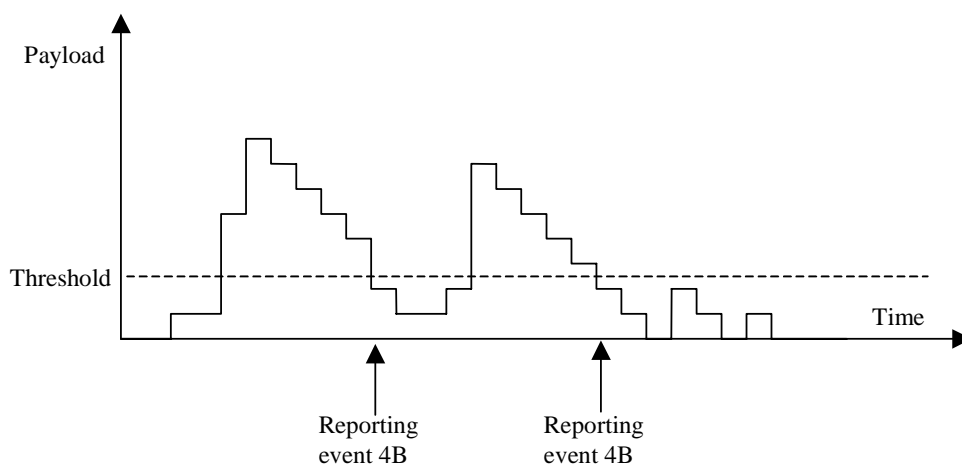

Figure 80: Event triggered report when RLC buffer payload becomes smaller than certain threshold

If the monitored payload becomes smaller than an absolute threshold, this is an event that could trigger a report. The corresponding report contains at least which transport channel triggered the report.

14.4.3 Traffic volume reporting mechanisms

Traffic volume measurement triggering could be associated with both a time-to-trigger and a pending time after trigger. The time-to-trigger is used to get time domain hysteresis, i.e. the condition must be fulfilled during the time-to-trigger time before a report is sent. Pending time after trigger is used to limit consecutive reports when one traffic volume measurement report already has been sent. This is described in detail below.

14.4.3.1 Pending time after trigger

This timer is started in the UE when a measurement report has been triggered. The UE is then forbidden to send any new measurement reports with the same measurement ID during this time period even when the triggering condition is fulfilled again. Instead the UE waits until the timer has suspended. If the payload is still above the threshold when the timer has expired the UE sends a new measurement report. Otherwise it waits for a new triggering.

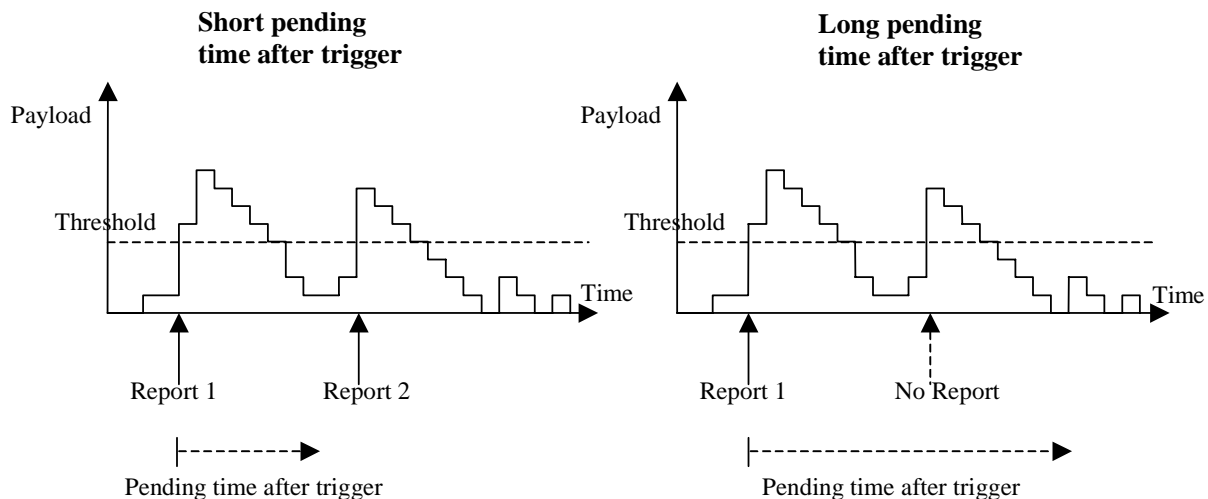

Figure 81: Pending time after trigger limits the amount of consecutive measurement reports

Figure 81 shows that by increasing the pending time after trigger a triggered second event does not result in a measurement report.

14.4.4 Interruption of user data transmission

A UE in CELL_FACH substate may be instructed by the UTRAN to cease transmission of user data on the RACH after a measurement report has been triggered. Before resuming transmission of user data,

- the UE shall receive from the UTRAN either a message allocating a dedicated physical channel, and make a transition to CELL_DCH state; or
- the UE shall receive an individually assigned measurement control message indicating that interruption of user data transmission is not be applied.

The transmission of signalling messages on the signalling bearer shall not be interrupted.

14.5 UE internal measurements

14.5.1 UE internal measurement quantities

For UE internal measurements the following measurement quantities exist:

1. UE transmission (Tx) power, for TDD measured on a timeslot basis.
2. UE received signal strength power (RSSI).
3. UE Rx-Tx time difference.

14.5.2 UE internal measurement reporting events

In the Measurement reporting criteria field in the Measurement Control messages, the UTRAN notifies the UE of which events should trigger a measurement report. UE internal measurement reporting events that can trigger a report are given below. The reporting events are marked with vertical arrows in the figures below. All events can be combined with time-to-trigger. In that case, the measurement report is only sent if the condition for the event has been fulfilled for the time given by the time-to-trigger parameter.

NOTE: The reporting events are numbered 6A, 6B, 6C,.. where 6 denotes that the event belongs to the type UE internal measurements.

14.5.2.1 Reporting event 6A: The UE Tx power becomes larger than an absolute threshold

When this event is ordered by UTRAN in a measurement control message, the UE shall send a measurement report when the UE transmission power (for TDD within a single TS) becomes larger than a predefined threshold. The corresponding report identifies the threshold that was exceeded.

14.5.2.2 Reporting event 6B: The UE Tx power becomes less than an absolute threshold

When this event is ordered by UTRAN in a measurement control message, the UE shall send a measurement report when the UE transmission power (for TDD within a single TS) becomes less than a predefined threshold. The corresponding report identifies the threshold that the UE Tx power went below.

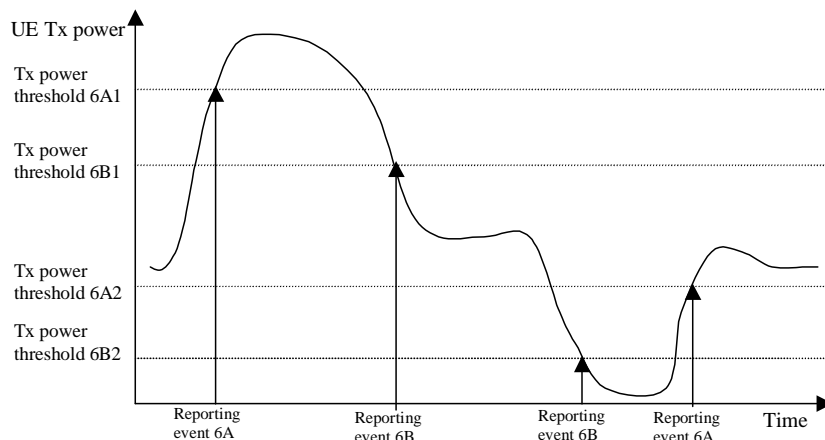

Figure 82: Event-triggered measurement reports when the UE Tx power becomes larger or less than absolute thresholds

14.5.2.3 Reporting event 6C: The UE Tx power reaches its minimum value

When this event is ordered by UTRAN in a measurement control message, the UE shall send a measurement report when the UE Tx power reaches its minimum value, for TDD its minimum value on a single timeslot.

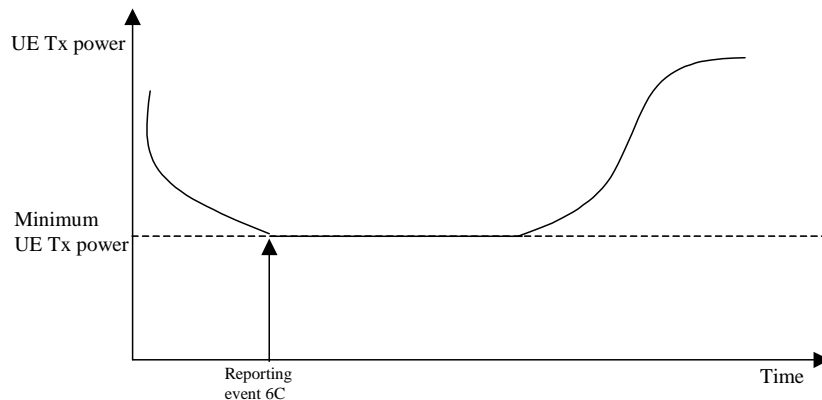

Figure 83: Event-triggered measurement report when the UE Tx power reaches its minimum value

14.5.2.4 Reporting event 6D: The UE Tx power reaches its maximum value

When this event is ordered by UTRAN in a measurement control message, the UE shall send a measurement report when the UE Tx power reaches its maximum value, for TDD its maximum value on a single timeslot.

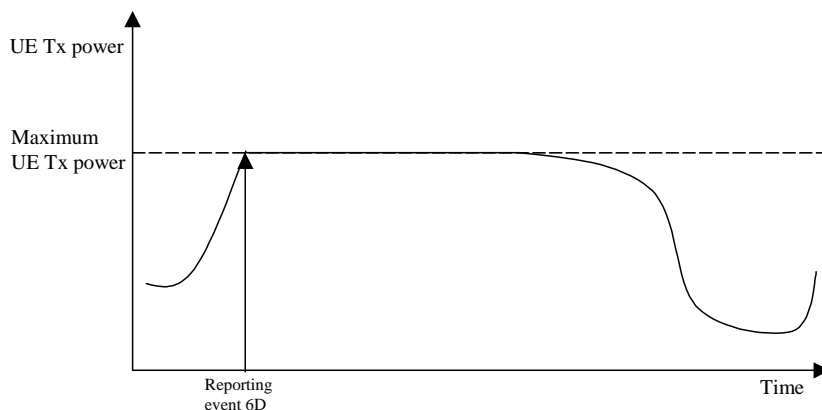

Figure 84: Event-triggered report when the UE Tx power reaches its maximum value

14.5.2.5 Reporting event 6E: The UE RSSI reaches the UE's dynamic receiver range

When this event is ordered by UTRAN in a measurement control message, the UE shall send a measurement report when the UE RSSI reaches the UE's dynamic receiver range.

14.5.2.6 Reporting event 6F: The UE Rx-Tx time difference for a RL included in the active set becomes larger than an absolute threshold

When this event is ordered by UTRAN in a MEASUREMENT CONTROL message, the UE shall send a measurement report message when the UE Rx-Tx time difference becomes larger than the threshold defined by the IE "UE Rx-Tx time difference threshold".

14.5.2.7 Reporting event 6G: The UE Rx-Tx time difference for a RL included in the active set becomes less than an absolute threshold

When this event is ordered by UTRAN in a MEASUREMENT CONTROL message, the UE shall send a measurement report when the UE Rx-Tx time difference becomes less than the threshold defined by the IE "UE Rx-Tx time difference threshold".

14.6 Dynamic Resource Allocation Control of Uplink DCH (FDD only)

The network uses this procedure to dynamically control the allocation of resources on an uplink DCH.

This procedure shall be activated in the UE when it has been allocated an uplink DCH with DRAC static information elements. Such uplink DCHs can be established through RB establishment procedure, RB reconfiguration procedure, RB release procedure or Transport Channel Reconfiguration procedure by setting the DRAC static information elements to indicate that the DCH is controlled by the DRAC procedure.

The UE shall periodically listen to the SIB 10 of each cell in its Active Set. The scheduling information of SIB10 and the SCCPCH info on which the SIB10 is transmitted are provided to the UE when the DCH is set up and when a cell is added in its active set. In case several SIB10 messages from different cells are scheduled at the same time, the UE shall only listen to the SIB10 broadcast in the cell of its Active Set having the best CPICH measurements.

Upon reception of a SYSTEM INFORMATION message comprising a SIB10, the UE shall:

1. Determine and store the most stringent DRAC parameters from the last received values from each cell of its active set (i.e. select the lowest product $ptr \cdot \text{maximum bit rate}$ corresponding to its DRAC class identity)
2. Determine the allowed subset of TFCS according to the selected maximum bit rate value, and store it for later usage.
The allowed subset of TFCS are the ones of the TFCS for which the sum of bit rates of the DCH controlled by DRAC is lower than Maximum Bit Rate IE, i.e.

$$\sum_{\text{DCH}_i \text{ controlled by DRAC}} TBSsize_i / TTI_i < \text{MaximumBitRate}$$

DCH_i controlled by DRAC

After the first SIB10 has been received, the UE shall start the following process:

1. At the start of the next TTI, the UE shall randomly select $p \in [0,1]$.
2. If $p < ptr$, the UE shall transmit on the DCH controlled by DRAC during Tvalidity frames using the last stored allowed subset of TFCS and comes back to step 1, otherwise the UE shall stop transmission on these DCH during Tretry frames and then comes back to step 1.

Transmission time validity (Tvalidity) and Time duration before retry (Tretry) are indicated to the UE at the establishment of a DCH controlled by this procedure and may be changed through RB or transport channel reconfiguration. The UE shall always use the latest received DRAC static parameters.

A UE which supports the simultaneous reception of one SCCPCH and one DPCH shall support the DRAC procedure.

14.7 Downlink power control

14.7.1 Generalities

This function is implemented in the UE in order to set the SIR target value on each CCTrCH used for the downlink power control. This SIR value shall be adjusted according to an autonomous function in the UE in order to achieve the same measured quality as the quality target set by UTRAN. The quality target is set as the transport channel BLER value for each transport channel as signalled by UTRAN. For CPCH the quality target is set as the BER of the DL DPCCH as signalled by UTRAN.

When transport channel BLER is used the UE shall run a quality target control loop such that the quality requirement is met for each transport channel, which has been assigned a BLER target.

When DL DPCCH BER is used the UE shall run a quality target control loop such that the quality requirement is met for each CPCH transport channel, which has been assigned a DL DPCCH BER target.

The UE shall set the SIR target when the physical channel has been set up or reconfigured. It shall not increase the SIR target value before the power control has converged on the current value. The UE may estimate whether the power control has converged on the current value, by comparing the averaged measured SIR to the SIR target value.

If the UE has received a DL outer loop control message from UTRAN indicating that the SIR target value shall not be increased above the current value, it shall record the current value as the maximum allowed value for the power control function, until it receives a new DL outer loop control message from UTRAN indicating that the restriction is removed.

14.7.2 Downlink power control in compressed mode

In compressed mode, the target SIR needs to be changed during compressed frames and one frame after compressed frames (recovery frame), compared to normal mode. For this purpose, four values DeltaSIR1, DeltaSIRafter1, DeltaSIR2 and DeltaSIRafter2 are signalled by the UTRAN to the UE (see section 10.2.9).

For each frame, the target SIR offset during compressed mode, compared to normal mode is:

$$\Delta\text{SIR} = \max(\Delta\text{SIR1_compression}, \dots, \Delta\text{SIRn_compression}) + \Delta\text{SIR_coding}$$

where n is the number of TTI lengths for all TrChs of the CCTrCh, F_i is the length in number of frames of the i-th TTI and where $\Delta\text{SIR_coding}$ fulfils:

- $\Delta\text{SIR_coding} = \text{DeltaSIR1}$ for compressed frames corresponding to the first transmission gap in the transmission gap pattern.
- $\Delta\text{SIR_coding} = \text{DeltaSIRafter1}$ for recovery frames corresponding to the first transmission gap in the transmission gap pattern.
- $\Delta\text{SIR_coding} = \text{DeltaSIR2}$ for compressed frames corresponding to the second transmission gap in the transmission gap pattern.
- $\Delta\text{SIR_coding} = \text{DeltaSIRafter2}$ for recovery frames corresponding to the second transmission gap in the transmission gap pattern.
- $\Delta\text{SIR_coding} = 0$ otherwise.

and $\Delta\text{SIRi_compression}$ is defined by :

- If the frames are compressed by reducing the spreading factor by 2 ("Compressed mode method" IE is equal to "SF/2"):
 - $\Delta\text{SIRi_compression} = 3$ dB for each compressed frame, where TGL is the gap length in number of slots (either from one gap or a sum of gaps) in the frame.
 - $\Delta\text{SIRi_compression} = 0$ otherwise.
- If the frames are compressed by puncturing ("Compressed mode method" IE is equal to "puncturing"):
 - $\Delta\text{SIRi_compression} = 10 \log(15 * F_i / (15 * F_i - \text{TGLi}))$ if there is a transmission gap within the current TTI of length F_i frames, where TGLi is the gap length in number of slots (either from one gap or a sum of gaps) in the current TTI of length F_i frames.
 - $\Delta\text{SIRi_compression} = 0$ otherwise.
- If the frames are compressed by upper layer scheduling ("Compressed mode method" IE is equal to "upper layer scheduling"):
 - $\Delta\text{SIRi_compression} = 0$ for all frames.

In the particular case where a transmission gap overlaps two frames (double-frame method), the second compressed frame (with the second part of the transmission gap) must be considered as the recovery frame ($\Delta\text{SIR_coding} = \text{DeltaSIRafter1}$ or $\Delta\text{SIR_coding} = \text{DeltaSIRafter2}$). Thus, in this case, the first frame following the two consecutive compressed frames is not considered as a recovery frame ($\Delta\text{SIR_coding} = 0$).

Several compressed mode patterns applying to the same frames should be avoided as much as possible.

In particular; several simultaneous patterns by puncturing applying to the same frames shall be considered as a protocol error by the UE. The handling of this error is described in the procedure descriptions in clause 8

In case several compressed mode patterns apply to the same frame or in case a frame is simultaneously a compressed frame in one pattern and a recovery frame in the same pattern or in another pattern, all offsets must be added and the total target SIR offset is applied to the frame.

14.8 Calculated Transport Format Combination

The Calculated Transport Format Combination (CTFC) is a tool for efficient signalling of transport format combinations.

Let I be the number of transport channels that are included in the transport format combination. Each transport channel TrChi , $i = 1, 2, \dots, I$, has L_i transport formats, i.e. the transport format indicator TFI_i can take L_i values,

$$\text{TFI}_i \in \{0, 1, 2, \dots, L_i - 1\}$$

$$P_i = \prod_{j=0}^{i-1} L_j$$

Define P_i , where $i = 1, 2, \dots, I$, and $L_0 = 1$.

Let $\text{TFC}(\text{TFI}_1, \text{TFI}_2, \dots, \text{TFI}_I)$ be the transport format combination for which TrCH1 has transport format TFI_1 , TrCH2 has transport format TFI_2 , etc. The corresponding $\text{CTFC}(\text{TFI}_1, \text{TFI}_2, \dots, \text{TFI}_I)$ is then computed as:

$$\text{CTFC}(\text{TFI}_1, \text{TFI}_2, \dots, \text{TFI}_I) = \sum_{i=1}^I \text{TFI}_i \cdot P_i$$

For downlink common CH, "TrChi" is numbered with ascending integer numbers starting from 1 in the order listed in a **SYSTEM INFORMATION** message.

In all other cases, for each separate TFCI field, "TrChi" is numbered with ascending integer numbers starting from 1 in the ascending order of transport channel identities of the channels mapped to that TFCI field.

14.9 UE autonomous update of active set on non-used frequency (FDD only)

Within the measurement reporting criteria field in the **MEASUREMENT CONTROL** message the UTRAN notifies the UE which events should trigger a measurement report. For inter frequency measurements it is possible to specify intra-frequency measurements reporting events for support of maintenance of a active set associated with a non-used frequency, a "virtual active set". A "non-used frequency" is a frequency that the UE has been ordered to measure upon but are not used by the active set. A "used frequency" is a frequency that the UE has been ordered to measure upon and is also currently used for the connection.

The autonomous update is controlled by the IE "UE autonomous update mode" that can be set to the following values.

- On: Do the autonomous updates of the "virtual active set" according to the described rules below and also report the events that trigger the update of the "virtual active set".
- On with no reporting: Do the autonomous updates of the "virtual active set" according to the described rules below.
- Off: Only report the events and do no updates of the "virtual active set" unless ordered to do so by the IE "Inter-frequency set update".

If the IE "UE autonomous update mode" is set to "on" or "on with no reporting" the UE shall evaluate the following intra-frequency events and update the "virtual active set" associated with the frequency measured upon, according to the following rules:

- Event 1a shall make the UE add the primary CPICH that enters the reporting range to the "virtual active set".
- Event 1b shall make the UE remove a primary CPICH that leaves the reporting range from the "virtual active set".

- Event 1c shall make the UE replace a active primary CPICH in the "virtual active set" with a non-active primary CPICH that have become better than the active primary CPICH.

14.10 Provision and reception of RRC information between network nodes

In certain cases, e.g., when performing handover to UTRAN or when performing SRNC relocation, RRC information may need to be transferred between other RATs and UTRAN or between UTRAN nodes within UTRAN. In the following, the details of the RRC information to be transferred are specified per direction.

14.10.1 RRC Information to target RNC

RRC Information to target RNC may either be sent from source RNC or from another RAT. In case of handover to UTRAN, this information originates from another RAT, while in case of SRNC relocation the RRC information originates from the source RNC. In case of SRNC information, the RRC information transferred specifies the configuration of RRC and the lower layers it controls, e.g., including the radio bearer and transport channel configuration. It is used by the target RNC to initialise RRC and the lower layer protocols to facilitate SRNC relocation in a manner transparent to the UE.

Information Element/Group Name	Need	Multi	Type and reference	Semantics description
Non RRC IEs				
CHOICE case	MP			
>Handover to UTRAN				
>>UE radio access capability	OP		UE radio access capability 10.3.3.40	
>>UE security information	OP		UE security information 14.13.2.2	
>>Pre-defined configuration status information	OP		Pre-defined configuration status information 14.13.2.3	
>SRNC relocation				
>>State of RRC	MP		Enumerated (CELL_DCH, CELL_FACH, CELL_PCH, URA_PCH)	
>>State of RRC procedure	MP		Enumerated (await no RRC message, await RRC Connection Re-establishment Complete, await RB Setup Complete, await RB Reconfiguration Complete, await RB Release Complete, await Transport CH Reconfiguration Complete, await Physical CH Reconfiguration Complete, await Active Set Update Complete, await Handover Complete, send Cell Update Confirm, send URA Update Confirm, send RRC Connection Re-establishment, others)	
Ciphering related information				
>>Ciphering status	MP		Enumerated(Not started, Started)	
>>Calculation time for ciphering related information	CV Ciphering			Time when the ciphering information of the message were calculated, relative to a cell of the target RNC
>>>Cell Identity	MP		Cell Identity 10.3.2.2	Identity of one of the cells under the target RNC and included in the active set of the current call
>>>SFN	MP		Integer(0..4095)	
>>Ciphering info per radio bearer	OP	1 to <maxRB >		
>>>RB identity	MP		RB identity 10.3.4.16	
>>>Downlink START	MP		START 10.3.3.36	
>>>Uplink START	MP		START 10.3.3.36	
Integrity protection related information				

Information Element/Group Name	Need	Multi	Type and reference	Semantics description
>>Integrity protection status	MP		Enumerated(Not started, Started)	
>>Signalling radio bearer specific integrity protection information	CV IP	4 to <maxSR Bsetup>		
RB identity	CV SRB5Plus		RB identity 10.3.4.16	For RB#0-4 the RB identity is not required
>>> Uplink RRC HFN	MP		Bitstring (28)	
>>> Downlink RRC HFN	MP		Bitstring (28)	
>>> Uplink RRC Message sequence number	MP		Integer (0..15)	
>>> Downlink RRC Message sequence number	MP		Integer (0..15)	
>>Implementation specific parameters	OP		Bitstring (1..512)	
RRC IEs				
UE Information elements				
>>U-RNTI	MP		U-RNTI 10.3.3.45	
>>C-RNTI	OP		C-RNTI 10.3.3.8	
>>UE radio access Capability	MP		UE radio access capability 10.3.3.40	
Other Information elements				
>>Inter System message (inter system classmark)	OP		Inter-system message 10.8.6	
UTRAN Mobility Information elements				
>>URA Identifier	OP		URA identity 10.3.2.6	
CN Information Elements				
>>CN common GSM-MAP NAS system information	MP		NAS system information (GSM-MAP) 10.3.1.9	
>>CN domain related information	OP	1 to <MaxCN domains >		CN related information to be provided for each CN domain
>>>CN domain identity	MP			
>>>CN domain specific GSM-MAP NAS system info	MP		NAS system information (GSM-MAP) 10.3.1.9	
Measurement Related Information elements				
>>For each ongoing measurement reporting	OP	1 to <MaxNo OfMeas>		
>>>Measurement Identity Number	MP		Measurement identity number 10.3.7.73	
>>>Measurement Command	MP		Measurement command 10.3.7.71	
>>>Measurement Type	CV Setup		Measurement type 10.3.7.75	
>>>Measurement Reporting Mode	OP		Measurement reporting mode 10.3.7.74	
>>>Additional Measurements list	OP		Additional measurements list 10.3.7.1	

Information Element/Group Name	Need	Multi	Type and reference	Semantics description
>>>CHOICE Measurement	OP			
>>>>Intra-frequency				
>>>>>Intra-frequency cell info	OP		Intra-frequency cell info list 10.3.7.33	
>>>>>Intra-frequency measurement quantity	OP		Intra-frequency measurement quantity 10.3.7.38	
>>>>>Intra-frequency reporting quantity	OP		Intra-frequency reporting quantity 10.3.7.41	
>>>>>Reporting cell status	OP		Reporting cell status 10.3.7.86	
>>>>>Measurement validity	OP		Measurement validity 10.3.7.76	
>>>>>CHOICE report criteria	OP			
>>>>>>Intra-frequency measurement reporting criteria			Intra-frequency measurement reporting criteria 10.3.7.39	
>>>>>>Periodical reporting			Periodical reporting criteria 10.3.7.78	
>>>>>>No reporting			NULL	
>>>>>Inter-frequency				
>>>>>>Inter-frequency cell info	OP		Inter-frequency cell info list 10.3.7.13	
>>>>>>Inter-frequency measurement quantity	OP		Inter-frequency measurement quantity 10.3.7.18	
>>>>>>Inter-frequency reporting quantity	OP		Inter-frequency reporting quantity 10.3.7.21	
>>>>>>Reporting cell status	OP		Reporting cell status 10.3.7.86	
>>>>>>Measurement validity	OP		Measurement validity 10.3.7.76	
>>>>>>CHOICE report criteria	OP			
>>>>>>>Inter-frequency measurement reporting criteria			Inter-frequency measurement reporting criteria 10.3.7.19	
>>>>>>>Periodical reporting			Periodical reporting criteria 10.3.7.78	
>>>>>>>No reporting			NULL	
>>>>>>Inter-system				
>>>>>>>Inter-system cell info	OP		Inter-system cell info list 10.3.7.23	
>>>>>>>Inter-system measurement quantity	OP		Inter-system measurement quantity 10.3.7.29	
>>>>>>>Inter-system reporting quantity	OP		Inter-system reporting quantity 10.3.7.32	
>>>>>>>Reporting cell status	OP		Reporting cell status 10.3.7.86	
>>>>>>>Measurement validity	OP		Measurement validity 10.3.7.76	
>>>>>>>CHOICE report criteria	OP			
>>>>>>>>Inter-system measurement reporting criteria			Inter-system measurement reporting criteria	

Information Element/Group Name	Need	Multi	Type and reference	Semantics description
			10.3.7.30	
>>>>>Periodical reporting			Periodical reporting criteria 10.3.7.78	
>>>>>No reporting			NULL	
>>>>Traffic Volume				
>>>>Traffic volume measurement Object	OP		Traffic volume measurement object 10.3.7.95	
>>>>Traffic volume measurement quantity	OP		Traffic volume measurement quantity 10.3.7.96	
>>>>Traffic volume reporting quantity	OP		Traffic volume reporting quantity 10.3.7.99	
>>>> CHOICE report criteria	OP			
>>>>>Traffic volume measurement reporting criteria			Traffic volume measurement reporting criteria 10.3.7.97	
>>>>>Periodical reporting			Periodical reporting criteria 10.3.7.78	
>>>>>No reporting			NULL	
>>>>Quality				
>>>>Quality measurement Object	OP		Quality measurement object	
>>>> CHOICE report criteria	OP			
>>>>>Quality measurement reporting criteria			Quality measurement reporting criteria 10.3.7.83	
>>>>>Periodical reporting			Periodical reporting criteria 10.3.7.78	
>>>>>No reporting			NULL	
>>>>UE internal				
>>>>>UE internal measurement quantity	OP		UE internal measurement quantity 10.3.7.104	
>>>>>UE internal reporting quantity	OP		UE internal reporting quantity 10.3.7.107	
>>>> CHOICE report criteria	OP			
>>>>>UE internal measurement reporting criteria			UE internal measurement reporting criteria 10.3.7.105	
>>>>>Periodical reporting			Periodical reporting criteria 10.3.7.78	
>>>>>No reporting			NULL	
Radio Bearer Information Elements				
>>Pre-defined configuration status information	OP		Pre-defined configuration status information 14.13.2.3	
>>Signalling RB information list	MP	1 to <maxSR Bsetup>		For each signalling radio bearer
>>>Signalling RB information	MP		Signalling RB information to setup 10.3.4.24	
>>RAB information list	OP	1 to <maxRA Bsetup>		Information for each RAB

Information Element/Group Name	Need	Multi	Type and reference	Semantics description
>>>RAB information	MP		RAB information to setup 10.3.4.10	
Transport Channel Information Elements				
Uplink transport channels				
>>UL Transport channel information common for all transport channels	OP		UL Transport channel information common for all transport channels 10.3.5.24	
>>UL transport channel information list	OP	1 to <MaxTrCH>		
>>>UL transport channel information	MP		Added or reconfigured UL TrCH information 10.3.5.2	
>>CHOICE mode	OP			
>>>FDD				
>>>>CPCH set ID	OP		CPCH set ID 10.3.5.5	
>>>>Transport channel information for DRAC list	OP	1 to <MaxTrCH>		
>>>>DRAC static information	MP		DRAC static information 10.3.5.7	
>>>TDD				(no data)
Downlink transport channels				
>>DL Transport channel information common for all transport channels	OP		DL Transport channel information common for all transport channels 10.3.5.6	
>>DL transport channel information list	OP	1 to <MaxTrCH>		
>>>DL transport channel information	MP		Added or reconfigured DL TrCH information 10.3.5.1	
>>Measurement report	OP		MEASUREMENT REPORT 10.2.17	
>spare				(no data) Criticality: reject

Multi Bound	Explanation
MaxNoOfMeas	Maximum number of active measurements, upper limit 16

Condition	Explanation
Setup	The IE is mandatory when the IE Measurement command has the value "Setup", otherwise the IE is not needed.
Ciphering	The IE is mandatory when the IE Ciphering Status has the value "started" and the ciphering counters need not be reinitialised, otherwise the IE is not needed.
IP	The IE is mandatory when the IE Integrity protection status has the value "started" and the ciphering counters need not be reinitialised, otherwise the IE is not needed.
SRB5Plus	The IE is mandatory when more than 5 signalling radio bearers are included
PDCP	The IE is mandatory when the PDCP Info IE is present, otherwise the IE is not needed.

14.10.2 RRC information, target RNC to source RNC

There are 2 possible cases for RNC relocation:

1. The UE is already under control of target RNC; and
2. The SRNC Relocation with Hard Handover (UE still under control of SRNC), but UE is moving to a location controlled by the target RNC (based on measurement information).

In case 1 the relocation is transparent to the UE and there is no "reverse" direction container. The SRNC just assigns the 'serving' function to the target RNC which then becomes the Serving RNC.

In case 2 the relocation is initiated by SRNC which also provides the RRC Initialization Information to the target RNC. Base on this information, the target RNC prepares the Hard Handover Message ("Physical channel reconfiguration" (subclause 8.2.6), "radio bearer establishment" (subclause 8.2.1), "Radio bearer reconfiguration" (subclause 8.2.2), "Radio bearer release" (subclause 8.2.3) or "Transport channel reconfiguration" (subclause 8.2.4).

The source RNC then transmits the Handover Message to the UE which then performs the handover.

In the successful case, the UE transmits an XXX COMPLETE message, using the new configuration, to the target RNC.

In case of failure, the UE transmits an XXX FAILURE, using the old configuration, to the source RNC and the RRC context remains unchanged (has to be confirmed and checked with the SRNS relocation procedure).

Information Element/Group name	Need	Multi	Type and reference	Semantics description
CHOICE RRC message	MP			
> RADIO BEARER SETUP			RADIO BEARER SETUP 10.2.31	
> RADIO BEARER RECONFIGURATION			RADIO BEARER RECONFIGURATION 10.2.25	
>RADIO BEARER RELEASE			RADIO BEARER RELEASE 10.2.28	
> TRANSPORT CHANNEL RECONFIGURATION			TRANSPORT CHANNEL RECONFIGURATION 10.2.51	
> PHYSICAL CHANNEL RECONFIGURATION			PHYSICAL CHANNEL RECONFIGURATION 10.2.20	

14.10.3 RRC information, target RNC to source system

The RRC information, target RNC to source system is used to transfer information to another RAT, e.g., in case of handover to UTRAN. In this case, the RRC information concerns the "Handover To UTRAN Command" that is compiled by the target RNC but transferred via another RAT towards the UE, as specified in 8.3.6.

Information Element/Group name	Need	Multi	Type and reference	Semantics description
CHOICE case	MP			
>handover to UTRAN			HANDOVER TO UTRAN COMMAND 10.2.10	
>spare				(no data) Criticality: reject

14.11 Versatile Channel Assignment Mode (VCAM) mapping rule (FDD only)

When Versatile Channel Assignment Method (VCAM) is used in the CPCH procedure, the following mapping rules shall be used to specify one PCPCH.

If the number of PCPCHs is less than or equal to 16, there is a one to one mapping between the CA index and the PCPCH index. Thus a suitable AP signature (and/or AP sub-channel) number is transmitted for the required spreading factor based on the broadcast system information, and the assigned PCPCH index (having the requested spreading factor) corresponds to the received CA index.

When the number of PCPCHs is greater than 16, a combination of an AP signature (and/or AP sub-channel) number and a CA signature number specifies one PCPCH as follows:

In VCAM mapping rule, a combination of an AP signature (and/or AP sub-channel) number and a CA signature number specifies one PCPCH. In a CPCH set, there are K available PCPCHs which are numbered $k=0,1,\dots,K-1$, and there are R available Minimum Spreading Factor $A_r, r=0,1,\dots,R-1$, that a UE can request and use. The maximum available number of PCPCHs and the number of available AP signatures (and/or AP sub-channels) for A_r are denoted as P_{0r} and S_r , respectively, for $r=0,1,\dots,R-1$. Let P_r be equal to 16 if P_{0r} is less than 16 and to P_{0r} otherwise. T_r represents the number of CA signatures for A_r which are needed for specifying PCPCH. The default value of T_r is 16.

S_r always satisfies $S_r \geq \min\{s : s \times T_r \geq P_r\}$.

The list of available AP signatures (and/or AP sub-channels) for each A_r is renumbered from signature index 0 to signature index $S_r - 1$, starting with the lowest AP signature (and/or AP sub-channel) number, and continuing in sequence, in the order of increasing signature numbers.

Then for given AP signature (and/or AP sub-channel) number and CA signature number, the number k that signifies the assigned PCPCH is obtained as:

$$k = \{[(i+n) \bmod S_r] + j S_r\} \bmod P_r,$$

where i ($i=0,1,\dots,S_r-1$) is the AP signature (and/or AP sub-channel) index for A_r , j ($j=0,1,\dots,\min(P_r,T_r)-1$) is the CA signature number for A_r and n is a nonnegative integer which satisfies

$$n M_r S_r \leq i + j S_r < (n+1) M_r S_r \text{ where } M_r = \min\{m : (m S_r) \bmod P_r = 0\}.$$

An example of the above mapping rule is shown in subclause 18.1.

14.12 LCS measurements

14.13 RRC information transferred between UE and other systems

This subclause specifies RRC information that is exchanged between other systems and the UE. This information is transferred via another RAT in accordance with the specifications applicable for those systems. This subclause specifies the UTRAN RRC information applicable for the different information flows.

14.13.1 RRC information, another RAT to UE

14.13.1.1 Pre-defined configuration information

Another system may provide the UE with one or more pre- defined UTRAN configurations, comprising of radio bearer, transport channel and physical channel parameters. The UE shall store the information, and use it upon handover to UTRAN if requested to do so within the handover to UTRAN command message. The pre- defined configuration information includes the following RRC information.

Information Element/Group name	Need	Multi	Type and reference	Semantics description
RB information elements				
Predefined radio configurations		1 to <maxPredefConfigCount>		
>Predefined configuration identity	MP		Predefined configuration identity 10.3.4.5	
>Predefined configuration value tag	OP		Predefined configuration value tag 10.3.4.6	
UE information elements				
Re-establishment timer	MP		Re-establishment timer 10.3.3.29	
RB information elements				
>Predefined RB configuration	MP		Predefined RB configuration 10.3.4.7	
TrCH Information Elements				
>Predefined TrCH configuration	MP		Predefined TrCH configuration 10.3.5.9	
PhyCH Information Elements				
>Predefined PhCH configuration	MP		Predefined PhyCH configuration 10.3.6.55	

Multi Bound	Explanation
MaxPredefConfigCount	Maximum number of predefined configurations

14.13.2 RRC information, UE to another RAT

14.13.2.1 UE capability information

Upon receiving a UE information request from another system, the UE shall indicate the requested capabilities. The UE capability information includes the following RRC information.

Information Element/Group name	Need	Multi	Type and reference	Semantics description
UE information elements				
UE radio access capability	OP		UE radio access capability 10.3.3.40	

14.13.2.2 UE security information

Upon receiving a UE information request from another system, the UE shall indicate the requested security information. The UE security information includes the following RRC information.

Information Element/Group name	Need	Multi	Type and reference	Semantics description
UE information elements				
START list	MP	1 to <MaxCNdo mains>		START [TS 33.102] values for all CN domains
>CN domain identity	MP		CN domain identity 10.3.1.1	
>START	MP		START 10.3.3.36	START values to be used in this CN domain.

14.13.2.3 Pre-defined configuration status information

Another system may provide the UE with one or more pre-defined UTRAN configurations, comprising of radio bearer, transport channel and physical channel parameters. If requested, the UE shall indicate the configurations it has stored. The pre-defined configuration status information should include the following RRC information.

Information Element/Group name	Need	Multi	Type and reference	Semantics description
RB information elements				
Predefined configurations		1 to <maxPred efConfigCo unt>		The list is in order of preconfiguration identity
>Predefined configuration value tag	OP		Predefined configuration value tag 10.3.4.6	The UE shall include the value tag if it has stored the concerned configuration

Multi Bound	Explanation
MaxPredefConfigCount	Maximum number of predefined configurations

15 Primitives between RRC and upper layers

The primitives between RRC and the upper layers are described in 3GPP TS 24.007.

16 Handling of unknown, unforeseen and erroneous protocol data

16.1 General

This subclause specifies procedures for the handling of unknown, unforeseen, and erroneous protocol data by the receiving entity. These procedures are called "error handling procedures", but in addition to provide recovery mechanisms for error situations they define a compatibility mechanism for future extensions of the protocol.

The error handling procedures specified in this subclause shall apply to all RRC messages. When there is a specific handling for messages received on different logical channels this is specified.

When the UE receives an RRC message, it shall set the variable `PROTOCOL_ERROR_REJECT` to `FALSE` and then perform the checks in the order as defined below.

The procedures specified in clause 8 are applied only for the messages passing the checks as defined below, except when procedure specific handling is used to recover from the error.

16.2 ASN.1 violation or encoding error

If the UE receives a message on the DCCH for which the encoded message does not result in a valid abstract syntax value, it shall perform the following:

- Set the variable `PROTOCOL_ERROR_REJECT` to `TRUE`.
- Transmit an RRC STATUS message on the uplink DCCH. The IE "Protocol error information" shall contain an IE "Protocol error cause" set to "ASN.1 violation or encoding error".
- ~~When the transmission of the RRC STATUS message has been confirmed by RLC~~ submitted to lower layers for transmission, the UE shall resume normal operation as if the invalid message has not been received.

If the UE receives a message on the BCCH, PCCH, CCCH or SHCCH for which the encoded message does not result in a valid abstract syntax value, it shall ignore the message.

16.3 Unknown or unforeseen message type

If a UE receives an RRC message on the DCCH with a message type reserved for future extension it shall:

- Set the variable `PROTOCOL_ERROR_REJECT` to `TRUE`.
- Transmit an RRC STATUS message on the uplink DCCH. The IE "Protocol error information" shall contain an IE "Protocol error cause" set to "Message type non-existent or not implemented".
- ~~When the transmission of the RRC STATUS message has been confirmed by RLC~~ submitted to lower layers for transmission, the UE shall resume normal operation as if the invalid message has not been received.

If the UE receives a message on the BCCH, PCCH, CCCH or SHCCH with a message type reserved for future extension it shall ignore the message.

16.4 Unknown or unforeseen information element value, mandatory information element

If the UE receives an RRC message on the DCCH, or addressed to the UE on the CCCH or on the SHCCH, with a mandatory IE having a value, including choice, reserved for future extension the UE shall

- If criticality of the IE is defined as "Ignore" and if a default value of the IE is defined, treat the rest of the message using the default value of the IE.
- If criticality of the IE is defined as "Reject" or no default value of the IE is defined:
 - Set the variable `PROTOCOL_ERROR_REJECT` to TRUE.
 - Set the IE "Protocol error cause" in the variable `PROTOCOL_ERROR_INFORMATION` to "Information element value not comprehended".
 - Perform procedure specific error handling according to clause 8.

If the UE receives an RRC message on the BCCH or PCCH with a mandatory IE having a value reserved for future extension it shall

- If criticality of the IE is defined as "Ignore" and if a default value of the IE is defined, treat the rest of the message using the default value of the IE.
- If criticality of the IE is defined as "Reject" or no default value of the IE is defined, ignore the message.

16.5 Conditional information element error

If the UE receives an RRC message on the DCCH, BCCH, PCCH, or addressed to the UE on the CCCH, for which the specified conditions for absence of a conditional IE are met and that IE is present, the UE shall:

- Ignore the IE.
- Treat the rest of the message as if the IE was not present.

If the UE receives an RRC message on the DCCH, or addressed to the UE on the CCCH or on the SHCCH, for which the specified conditions for presence of a conditional IE are met and that IE is absent, the UE shall:

- Set the variable `PROTOCOL_ERROR_REJECT` to TRUE.
- Set the IE "Protocol error cause" in the variable `PROTOCOL_ERROR_INFORMATION` to "Conditional information element error".
- Perform procedure specific error handling according to clause 8.

If the UE receives an RRC message on the BCCH or PCCH for which the specified conditions for presence of a conditional IE are met and that IE is absent, the UE shall ignore the message.

16.6 Unknown or unforeseen information element value, conditional information element

If the UE receives an RRC message on the DCCH, or addressed to the UE on the CCCH or on the SHCCH, for which the specified conditions for presence of a conditional IE are met, that IE is present, and that IE has a value, including choice, reserved for future extension, the UE shall

- If criticality of the IE is defined as "Ignore" and if a default value of the IE is defined, treat the rest of the message using the default value of the IE.
- If criticality of the IE is defined as "Reject" or no default value of the IE is defined:
 - Set the variable `PROTOCOL_ERROR_REJECT` to TRUE.
 - Set the IE "Protocol error cause" in the variable `PROTOCOL_ERROR_INFORMATION` to "Information element value not comprehended".
 - Perform procedure specific error handling according to clause 8.

If the UE receives an RRC message on the BCCH or PCCH for which the specified conditions for presence of a conditional IE are met, that IE is present, and that IE has a value, including choice, reserved for future extension, the UE shall

- If criticality of the IE is defined as "Ignore" and if a default value of the IE is defined, treat the rest of the message using the default value of the IE.
- If criticality of the IE is defined as "Reject" or no default value of the IE is defined, ignore the message.

16.7 Unknown or unforeseen information element value, optional information element

If the UE receives an RRC message on the DCCH, or addressed to the UE on the CCCH or on the SHCCH, with an optional IE having a value, including choice, reserved for future extension and the criticality for that IE is specified as "ignore", it shall:

- Ignore the value of the IE.
- Treat the rest of the message as if the IE was not present.

If the UE receives an RRC message on the DCCH, or addressed to the UE on the CCCH or on the SHCCH, with an optional IE having a value, including choice, reserved for future extension and the criticality for that IE is specified as "reject", it shall:

- Set the variable `PROTOCOL_ERROR_REJECT` to TRUE.
- Set the IE "Protocol error cause" in the variable `PROTOCOL_ERROR_INFORMATION` to "Information element value not comprehended".
- Perform procedure specific error handling according to clause 8.

If the UE receives an RRC message on the BCCH or PCCH with an optional IE having a value, including choice, reserved for future extension it shall:

- Ignore the value of the IE.
- Treat the rest of the message as if the IE was not present.

16.8 Unexpected message extension

If the UE receives a message on the DCCH, or addressed to the UE on the CCCH or on the SHCCH, containing at least one information element in an extension for which a content is not defined, and therefore not expected, the UE shall check the criticality of that extension, if defined.

- If the criticality for the extension is defined and is set to "Ignore", the UE shall ignore the content of the extension and the message contents after the extension, but treat the parts of the message up to the extension normally.
- If the criticality for the extension is defined and is set to "Reject", or if the criticality is not defined, the UE shall:
 - Set the variable `PROTOCOL_ERROR_REJECT` to TRUE.
 - Set the IE "Protocol error cause" in the variable `PROTOCOL_ERROR_INFORMATION` to "Message extension not comprehended".
 - Perform procedure specific error handling according to clause 8.

If the UE receives a message on the BCCH or PCCH, containing at least one information element in an extension for which a content is not defined, and therefore not expected, the UE shall check the criticality of that extension, if defined.

- If the criticality for the extension is defined and is set to "Ignore", the UE shall ignore the content of the extension and the message contents after the extension, but treat the parts of the message up to the extension normally.
- If the criticality for the extension is defined and is set to "Reject", or if the criticality is not defined, the UE shall ignore the message.

~~17~~ ~~SDL~~

~~This subclause describes the functionality of the protocol in descriptive SDL.~~

18 Appendices: Examples of operation

18.1 Example of VCAM mapping rule

Table 18.1.1: Example of Mapping Rule for PCPCH ≥ 16

PCPCH (k)	SF = 128			SF = 256			
0	AP0(AP0), CA0	AP2(AP1), CA7	AP1(AP2), CA14	AP0(AP3), CA0	AP1(AP4), CA5	AP2 (AP5), CA10	AP3(AP6), CA15
1	AP1(AP1), CA0	AP0(AP2), CA7	AP2(AP0), CA14	AP1(AP4), CA0	AP2(AP5), CA5	AP3(AP6), CA10	
2	AP2(AP2), CA0	AP1(AP0), CA7	AP0(AP1), CA14	AP2(AP5), CA0	AP3(AP6), CA5	AP0(AP3), CA11	
3	AP0(AP0), CA1	AP2(AP1), CA8	AP1(AP2), CA15	AP3(AP6), CA0	AP0(AP3), CA6	AP1(AP4), CA11	
4	AP1(AP1), CA1	AP0(AP2), CA8	AP2(AP0), CA15	AP0(AP3), CA1	AP1 (AP4), CA6	AP2(AP5), CA11	
5	AP2(AP2), CA1	AP1(AP0), CA8	AP0(AP1), CA15	AP1(AP4), CA1	AP2(AP5), CA6	AP3(AP6), CA11	
6	AP0(AP0), CA2	AP2(AP1), CA9		AP2(AP5), CA1	AP3(AP6), CA6	AP0(AP3), CA12	
7	AP1(AP1), CA2	AP0(AP2), CA9		AP3(AP6), CA1	AP0(AP3), CA7	AP1(AP4), CA12	
8	AP2(AP2), CA2	AP1(AP0), CA9		AP0(AP3), CA2	AP1(AP4), CA7	AP2(AP5), CA12	
9	AP0(AP0), CA3	AP2(AP1), CA10		AP1(AP4), CA2	AP2(AP5), CA7	AP3(AP6), CA12	
10	AP1(AP1), CA3	AP0(AP2), CA10		AP2(AP5), CA2	AP3(AP6), CA7	AP0(AP3), CA13	
11	AP2(AP2), CA3	AP1(AP0), CA10		AP3(AP6), CA2	AP0(AP3), CA8	AP1(AP4), CA13	
12	AP0(AP0), CA4	AP2(AP1), CA11		AP0(AP3), CA3	AP1(AP4), CA8	AP2(AP5), CA13	
13	AP1(AP1), CA4	AP0(AP2), CA11		AP1(AP4), CA3	AP2(AP5), CA8	AP3(AP6), CA13	
14	AP2(AP2), CA4	AP1(AP0), CA11		AP2(AP5), CA3	AP3(AP6), CA8	AP0(AP3), CA14	
15	AP0(AP0), CA5	AP2(AP1), CA12		AP3(AP6), CA3	AP0(AP3), CA9	AP1(AP4), CA14	
16	AP1(AP1), CA5	AP0(AP2), CA12		AP0(AP3), CA4	AP1(AP4), CA9	AP2(AP5), CA14	
17	AP2(AP2), CA5	AP1(AP0), CA12		AP1(AP4), CA4	AP2(AP5), CA9	AP3(AP6), CA14	
18	AP0(AP0), CA6	AP2(AP1), CA13		AP2(AP5), CA4	AP3(AP6), CA9	AP0(AP3), CA15	
19	AP1(AP1), CA6	AP0(AP2), CA13		AP3(AP6), CA4	AP0(AP3), CA10	AP1(AP4), CA15	
20	AP2(AP2), CA6	AP1(AP0), CA13		AP0(AP3), CA5	AP1(AP4), CA10	AP2(AP5), CA15	

NOTE: —

— SF (A0) = 128, Number of AP (S0) = 3: Re-numbered AP0 = AP0, AP1 = AP1, AP2 = AP2

— SF (A1) = 256, Number of AP (S1) = 4: Re-numbered AP3 = AP0, AP4 = AP1, AP5 = AP2, AP6 = AP3

— P0=P1=21

— T0=T1=16.

— In this example, M0=7, M1=21

Annex A (informative): USIM parameters

A.1 Introduction

This annex contains recommendations about the network-RRC parameters to be stored in the USIM.

A.2 Ciphering information

Information Element/Group name	Need	Multi	Type and reference	Semantics description
Cipher key for each CN domain	MP	<1 to maxCNDomains>		Cipher key is described in 33.102.
> Old CK	MP		Bitstring (128)	
> New CK	MP		Bitstring (128)	
Integrity key for each CN domain	MP	<1 to maxCNDomains>		Integrity key is described in 33.102.
> Old IK	MP		Bitstring (128)	
> New IK	MP		Bitstring (128)	
START value for each CN domain	MP	<1 to maxCNDomains>		START value is described in 33.102.
> Old START	MP		Bitstring (20)	
> New START	MP		Bitstring (20)	
KSI, Key set identifier for each CN domain	MP	<1 to maxCNDomains>		Key set identifier is described in 33.102.
> Old KSI	MP		Bitstring (3)	
> New KSI	MP		Bitstring (3)	

A.3 Frequency information

Neighbour cell list

Information Element/Group name	Need	Multi	Type and reference	Semantics description
FDD cell list	OP	<1 to maxFDDFreqList>		
>UARFCN uplink (Nu)	OP		Integer(0..16383)	[25.101] If IE not present, default duplex distance of 190 MHz shall be used.
>UARFCN downlink (Nd)	MP		Integer(0 .. 16383)	[25.101]
> Primary scrambling code	OP	<1 to maxFDDFreqCellList>	Primary CPICH info 10.3.6.59	
TDD cell list	OP	<1 to maxTDDFreqList>		
>UARFCN (Nt)	MP		Integer(0 .. 16383)	[25.102]
> Cell parameters ID	OP	<1 to maxTDDFreqCellList>	Integer (0..127)	The Cell parameters ID is described in 25.223.
GSM Neighbour cell list	OP			
>GSM neighbour cell info	MP	<1 to maxGSMCellList>		
>> BSIC	MP			
>> BCCH ARFCN	MP			

A.4 Multiplicity values and type constraint values

Constant	Explanation	Value
Ciphering information		
maxCNDomains	Maximum number of CN domains	4
Frequency information		
maxFDDFreqList	Maximum number of FDD carrier frequencies to be stored in USIM	4
maxTDDFreqList	Maximum number of TDD carrier frequencies to be stored in USIM	4
maxFDDFreqCellList	Maximum number of neighbouring FDD cells on one carrier to be stored in USIM	32
maxTDDFreqCellList	Maximum number of neighbouring TDD cells on one carrier to be stored in USIM	32
maxGSMCellList	Maximum number of GSM cells to be stored in USIM	32

Annex B (informative): Change history

Change history					
TSG-RAN#	Version	CR	Tdoc RAN	New Version	Subject/Comment
RAN_05	-	-	RP-99524	3.0.0	(10/99) Approved at TSG-RAN #5 and placed under Change Control
RAN_06	3.0.0	001	RP-99650	3.1.0	(12/99) Modification of RRC procedure specifications
RAN_06	3.0.0	005	RP-99654	3.1.0	Introduction of Information Element for Power Control Algorithm
RAN_06	3.0.0	007	RP-99654	3.1.0	RRC parameters for SSdT
RAN_06	3.0.0	009	RP-99656	3.1.0	Inclusion of information elements for integrity protection
RAN_06	3.0.0	010	RP-99656	3.1.0	Security mode control procedure
RAN_06	3.0.0	011	RP-99656	3.1.0	Updates of the system information procedure
RAN_06	3.0.0	012	RP-99656	3.1.0	Inter-frequency measurements and reporting
RAN_06	3.0.0	013	RP-99656	3.1.0	Inter-system measurements and reporting
RAN_06	3.0.0	014	RP-99656	3.1.0	Additional measurements in RRC measurement messages
RAN_06	3.0.0	015	RP-99656	3.1.0	Value range for Measurement Information Elements
RAN_06	3.0.0	016	RP-99656	3.1.0	Message contents for inter system handover to UTRAN
RAN_06	3.0.0	017	RP-99652	3.1.0	Inclusion of ciphering information elements
RAN_06	3.0.0	018	RP-99651	3.1.0	Corrections and editorial changes
RAN_06	3.0.0	019	RP-99654	3.1.0	Algorithm for CTCF Calculation
RAN_06	3.0.0	025	RP-99651	3.1.0	Logical CH for RRC Connection Re-establishment
RAN_06	3.0.0	026	RP-99719	3.1.0	Gain Factors
RAN_06	3.0.0	027	RP-99654	3.1.0	Parameters for CELL UPDATE CONFIRM message
RAN_06	3.0.0	028	RP-99651	3.1.0	Cell Update Cause
RAN_06	3.0.0	029	RP-99654	3.1.0	RRC Initialization Information
RAN_06	3.0.0	034	RP-99656	3.1.0	Open loop power control for PRACH
RAN_06	3.0.0	038	RP-99652	3.1.0	Addition of the UE controlled AMR mode adaptation
RAN_06	3.0.0	039	RP-99651	3.1.0	Information elements for RLC reset
RAN_06	3.0.0	040	RP-99656	3.1.0	Support for DS-41 Initial UE Identity
RAN_06	3.0.0	042	RP-99656	3.1.0	Integration of Cell Broadcast Service (CBS)
RAN_06	3.0.0	044	RP-99654	3.1.0	Gated transmission of DPCCH
RAN_06	3.0.0	045	RP-99656	3.1.0	Modification to the Transport Format Combination Control message
RAN_06	3.0.0	046	RP-99656	3.1.0	New Information elements and modifications to messages required in order to support configuration and re-configuration of the DSCH in FDD mode
RAN_06	3.0.0	047	RP-99654	3.1.0	Editorial Corrections and Alignments with Layer 1 specifications
RAN_06	3.0.0	048	RP-99654	3.1.0	Information elements for TDD shared channel operation
RAN_06	3.0.0	049	RP-99656	3.1.0	Description of CN dependent IEs in Master Information Block
RAN_06	3.0.0	050	RP-99650	3.1.0	UE capability information elements
RAN_06	3.0.0	051	RP-99656	3.1.0	UTRAN response time to uplink feedback commands of TX diversity control
RAN_06	3.0.0	052	RP-99654	3.1.0	New and corrected CPCH parameters
RAN_06	3.0.0	053	RP-99654	3.1.0	Compressed mode parameters without gating
RAN_06	3.0.0	054	RP-99654	3.1.0	Transport format combination set and transport format combination subset
RAN_06	3.0.0	055	RP-99656	3.1.0	Information elements for cell selection and reselection
RAN_06	3.0.0	056	RP-99654	3.1.0	Corrections and Alignments of the RRC to the L1 for TDD
RAN_06	3.0.0	057	RP-99656	3.1.0	Introduction of a SCCH procedure
RAN_06	3.0.0	061	RP-99656	3.1.0	Support for DS-41 Paging UE Identity
RAN_06	3.0.0	062	RP-99656	3.1.0	Support for cdma2000 Hard Handover
RAN_06	3.0.0	063	RP-99656	3.1.0	Provide necessary signalling to support FDD DSCH
RAN_06	3.0.0	064	RP-99654	3.1.0	RRC procedure interactions
RAN_06	3.0.0	066	RP-99654	3.1.0	Transfer of UE capabilities
RAN_06	3.0.0	067	RP-99654	3.1.0	Selection of initial UE identity

Change history					
TSG-RAN#	Version	CR	Tdoc RAN	New Version	Subject/Comment
RAN_06	3.0.0	069	RP-99657	3.1.0	UE capability verification in the security mode control procedure
RAN_06	3.0.0	070	RP-99657	3.1.0	DPCH initial power
RAN_06	3.0.0	071	RP-99657	3.1.0	Actions when entering idle mode
RAN_06	3.0.0	072	RP-99657	3.1.0	Specification of inter-frequency and inter-system reporting events for FDD
RAN_06	3.0.0	073	RP-99657	3.1.0	Signalling radio bearers
RAN_06	3.0.0	074	RP-99654	3.1.0	CN information elements
RAN_06	3.0.0	076	RP-99654	3.1.0	UE information elements
RAN_06	3.0.0	077	RP-99657	3.1.0	Radio bearer, transport channel and physical channel information elements
RAN_06	3.0.0	078	RP-99654	3.1.0	Other information elements
RAN_06	3.0.0	079	RP-99657	3.1.0	RRC signalling for PDCP
RAN_06	3.0.0	080	RP-99654	3.1.0	Content of Measurement Control Messages
RAN_06	3.0.0	081	RP-99654	3.1.0	RRC Information Elements to support Block STTD transmission diversity in TDD
RAN_06	3.0.0	082	RP-99657	3.1.0	Signalling connection release
RAN_06	3.0.0	083	RP-99657	3.1.0	Addition of cell access restriction information elements to System Information
RAN_06	3.0.0	085	RP-99655	3.1.0	RRC Connection Establishment parameters
RAN_06	3.0.0	092	RP-99657	3.1.0	Support of UE autonomous update of a active set on a non-used frequency
RAN_06	3.0.0	095	RP-99657	3.1.0	TPC combining for power control
RAN_06	3.0.0	096	RP-99653	3.1.0	Editorial Modification of IEs in RRC messages
RAN_06	3.0.0	097	RP-99655	3.1.0	Selection of SCCPCH
RAN_06	3.0.0	098	RP-99655	3.1.0	RRC Initialization Information
RAN_06	3.0.0	100	RP-99657	3.1.0	Support of physical channel establishment and failure criteria in the UE
RAN_06	3.0.0	102	RP-99655	3.1.0	RRC Connection Re-establishment
RAN_06	3.0.0	106	RP-99657	3.1.0	System information on FACH
RAN_06	3.0.0	108	RP-99657	3.1.0	SAPs and Primitives for DS-41 mode
RAN_06	3.0.0	109	RP-99655	3.1.0	TX Diversity Mode for Dedicated Channel
RAN_06	3.0.0	110	RP-99657	3.1.0	RACH message length signaling on System Information
RAN_06	3.0.0	113	RP-99657	3.1.0	Routing of NAS messages in UTRAN
RAN_06	3.0.0	116	RP-99655	3.1.0	TBS Identification in TFS
RAN_06	3.0.0	117	RP-99657	3.1.0	Merging the hard handover and some radio bearer control procedures
RAN_06	3.0.0	120	RP-99653	3.1.0	Selected RRC message transfer syntax
RAN_06	3.0.0	121	RP-99657	3.1.0	Efficient rate command signalling
RAN_07	3.1.0	122	RP-000043	3.2.0	(03/00) TDD Mode BCH Reception in Cell DCH State
RAN_07	3.1.0	123	RP-000043	3.2.0	Uplink Outer Loop Power Control in TDD Mode
RAN_07	3.1.0	124	RP-000043	3.2.0	TFS TB Size Calculation with Bit Aligned TDD MAC Headers
RAN_07	3.1.0	125	RP-000043	3.2.0	Grouping of DRAC IEs, and detailed definitions of these IEs
RAN_07	3.1.0	126	RP-000043	3.2.0	Correction of specifications for the 'Dynamic Resource Allocation Control of Uplink DCH' Procedure
RAN_07	3.1.0	131	RP-000043	3.2.0	Clarification of PDCP info and PDCP capability IEs
RAN_07	3.1.0	132	RP-000043	3.2.0	Editorial change to "Specification of system information block characteristics"
RAN_07	3.1.0	133	RP-000043	3.2.0	Additions of CBS related Information Elements
RAN_07	3.1.0	134	RP-000043	3.2.0	Signalling for computed gain factors
RAN_07	3.1.0	137	RP-000043	3.2.0	General error handling procedures
RAN_07	3.1.0	138	RP-000043	3.2.0	RRC message extensions

Change history					
TSG-RAN#	Version	CR	Tdoc RAN	New Version	Subject/Comment
RAN_07	3.1.0	139	RP-000043	3.2.0	Padding of RRC messages using RLC transparent mode
RAN_07	3.1.0	140	RP-000043	3.2.0	UE information elements
RAN_07	3.1.0	141	RP-000043	3.2.0	Other information elements
RAN_07	3.1.0	142	RP-000043	3.2.0	Integrity protection function
RAN_07	3.1.0	143	RP-000043	3.2.0	RAB-RB relations
RAN_07	3.1.0	144	RP-000043	3.2.0	Inter-system handover from UTRAN
RAN_07	3.1.0	145	RP-000043	3.2.0	Handover to UTRAN including procedure for pre-configuration
RAN_07	3.1.0	146	RP-000043	3.2.0	RRC measurement filtering parameters
RAN_07	3.1.0	147	RP-000043	3.2.0	New event "RL out of UE Rx window"
RAN_07	3.1.0	148	RP-000044	3.2.0	Access control on RACH
RAN_07	3.1.0	149	RP-000044	3.2.0	cdma2000 Hard Handover
RAN_07	3.1.0	150	RP-000044	3.2.0	CPCH parameters with corrections
RAN_07	3.1.0	152	RP-000044	3.2.0	U-plane AM RLC reconfiguration by cell update procedure
RAN_07	3.1.0	154	RP-000044	3.2.0	CPCH
RAN_07	3.1.0	155	RP-000044	3.2.0	Information elements for ASC in TDD
RAN_07	3.1.0	156	RP-000044	3.2.0	Addition of timing advance value in handover related messages
RAN_07	3.1.0	157	RP-000044	3.2.0	Physical channel description for TDD
RAN_07	3.1.0	159	RP-000044	3.2.0	Message contents for the intersystem command message to UTRAN operating in TDD mode
RAN_07	3.1.0	160	RP-000044	3.2.0	Corrections on use of PUSCH power control info and minor corrections
RAN_07	3.1.0	162	RP-000044	3.2.0	UE individual DRX cycles in CELL_PCH and URA_PCH states
RAN_07	3.1.0	163	RP-000044	3.2.0	Correction to Transport Format Combination Control procedure
RAN_07	3.1.0	164	RP-000044	3.2.0	Downlink outer loop power control
RAN_07	3.1.0	165	RP-000044	3.2.0	Redirection of RRC connection setup
RAN_07	3.1.0	166	RP-000044	3.2.0	Inter-frequency measurements in CELL_FACH state
RAN_07	3.1.0	167	RP-000044	3.2.0	List of found editorial mistakes in the Dec99 version of 25.331 (V3.1.0)
RAN_07	3.1.0	168	RP-000044	3.2.0	Transport block size
RAN_07	3.1.0	169	RP-000044	3.2.0	Cell Access Restriction
RAN_07	3.1.0	170	RP-000044	3.2.0	Editorial modification
RAN_07	3.1.0	171	RP-000044	3.2.0	Modification of DPCH info
RAN_07	3.1.0	172	RP-000045	3.2.0	Measurement control message
RAN_07	3.1.0	173	RP-000045	3.2.0	Reporting cell status

Change history					
TSG-RAN#	Version	CR	Tdoc RAN	New Version	Subject/Comment
RAN_07	3.1.0	174	RP-000045	3.2.0	Additional IE for RB release
RAN_07	3.1.0	175	RP-000045	3.2.0	Available SF in PRACH info
RAN_07	3.1.0	176	RP-000045	3.2.0	Traffic volume measurement event
RAN_07	3.1.0	177	RP-000045	3.2.0	Report of multiple cells on an event result
RAN_07	3.1.0	178	RP-000045	3.2.0	Editorial modification on Direct Transfer
RAN_07	3.1.0	179	RP-000045	3.2.0	Correction of the Security Mode Control procedure
RAN_07	3.1.0	180	RP-000045	3.2.0	Maximum calculated Transport Format Combination
RAN_07	3.1.0	183	RP-000045	3.2.0	Additional DPCH IEs to align 25.331 with 25.214
RAN_07	3.1.0	184	RP-000045	3.2.0	RB – DCH mapping
RAN_07	3.1.0	188	RP-000045	3.2.0	Modifications related to FDD mode DSCH
RAN_07	3.1.0	189	RP-000045	3.2.0	Identification of Shared Channel Physical Configuration in TDD Mode
RAN_07	3.1.0	192	RP-000045	3.2.0	Uplink Outer Loop Power Control During Hard Handover
RAN_07	3.1.0	193	RP-000045	3.2.0	Support of Multiple CCTrCH's in TDD Mode
RAN_07	3.1.0	194	RP-000045	3.2.0	Uplink Physical Channel Control in TDD Mode
RAN_07	3.1.0	201	RP-000045	3.2.0	Transfer of initial information from UE to target RNC prior to handover to UTRAN
RAN_07	3.1.0	202	RP-000045	3.2.0	CN information elements
RAN_07	3.1.0	203	RP-000045	3.2.0	UTRAN mobility information elements
RAN_07	3.1.0	204	RP-000045	3.2.0	RB information elements
RAN_07	3.1.0	205	RP-000046	3.2.0	Physical channel information elements
RAN_07	3.1.0	206	RP-000046	3.2.0	UE capability information elements
RAN_07	3.1.0	207	RP-000046	3.2.0	UE variables
RAN_07	3.1.0	208	RP-000046	3.2.0	Actions when entering idle mode
RAN_07	3.1.0	209	RP-000046	3.2.0	Usage of pilot bits
RAN_07	3.1.0	210	RP-000046	3.2.0	System information procedure corrections
RAN_07	3.1.0	212	RP-000046	3.2.0	Reconfiguration of ciphering
RAN_07	3.1.0	213	RP-000046	3.2.0	Enhancements to RRC connection re-establishment procedure
RAN_07	3.1.0	215	RP-000046	3.2.0	Updates to RRC Initialization Information transparent container and addition of reverse direction container description
RAN_07	3.1.0	220	RP-000046	3.2.0	Changes in RRC messages to support lossless SRNC relocation
RAN_07	3.1.0	229	RP-000046	3.2.0	Measurements of unlisted neighbouring cells
RAN_07	3.1.0	234	RP-000046	3.2.0	Inclusion of Location Services
RAN_07	3.1.0	236	RP-000046	3.2.0	Application of Access Service Classes and relation to Access Classes

Change history					
TSG-RAN#	Version	CR	Tdoc RAN	New Version	Subject/Comment
RAN_07	3.1.0	252	RP-000046	3.2.0	DRX indicator RRC State Indicator presence and state entering mechanism at the end of a procedure
RAN_07	3.1.0	254	RP-000046	3.2.0	Physical shared channel allocation procedure
RAN_07	3.1.0	255	RP-000046	3.2.0	Corrections to TDD specific parameters in PICH info
RAN_07	3.1.0	256	RP-000046	3.2.0	Editorial modifications
RAN_07	3.1.0	259	RP-000046	3.2.0	Introduction of mapping function information in Cell selection and
RAN_07	3.1.0	263	RP-000046	3.2.0	Ciphering and integrity HFN
RAN_07	3.1.0	267	RP-000046	3.2.0	New SIB for LCS
RAN_07	3.1.0	268	RP-000047	3.2.0	Removal of synchronization Case 3
RAN_07	3.1.0	271	RP-000047	3.2.0	TX Diversity
RAN_07	3.1.0	272	RP-000047	3.2.0	Update of tabular format clause 10
RAN_07	3.1.0	273	RP-000047	3.2.0	ASN.1 description
RAN_08	3.2.0	228	RP-000222	3.3.0	(06/00) Downlink power control in compressed mode
RAN_08	3.2.0	260	RP-000222	3.3.0	Clarification on physical channel allocations in TDD
RAN_08	3.2.0	261	RP-000222	3.3.0	TDD Measurements and Reporting
RAN_08	3.2.0	262	RP-000222	3.3.0	Signalling of IEs related to System Information on FACH
RAN_08	3.2.0	265	RP-000222	3.3.0	Transport Format Combination Control
RAN_08	3.2.0	269	RP-000222	3.3.0	Signalling of partial failure in radio bearer related procedures
RAN_08	3.2.0	275	RP-000222	3.3.0	Clarification on PDCP info
RAN_08	3.2.0	279	RP-000222	3.3.0	Editorial modification on Transport Ch capability
RAN_08	3.2.0	280	RP-000222	3.3.0	Editorial modification on CN IE
RAN_08	3.2.0	281	RP-000222	3.3.0	Editorial modification on Physical CH IE
RAN_08	3.2.0	282	RP-000222	3.3.0	Editorial modification on ASN.1 description
RAN_08	3.2.0	283	RP-000222	3.3.0	IEs on SIB5/6
RAN_08	3.2.0	285	RP-000222	3.3.0	Re-establishment timer
RAN_08	3.2.0	286	RP-000222	3.3.0	CN DRX cycle coefficient
RAN_08	3.2.0	287	RP-000222	3.3.0	Cell Access Restriction
RAN_08	3.2.0	288	RP-000222	3.3.0	Cell selection and re-selection parameters
RAN_08	3.2.0	289	RP-000222	3.3.0	Modification on Measurement IE
RAN_08	3.2.0	291	RP-000222	3.3.0	RACH Transmission parameters
RAN_08	3.2.0	292	RP-000222	3.3.0	SCCPCH System Info
RAN_08	3.2.0	293	RP-000222	3.3.0	Addition of HFN for RRC CONNECTION RE-ESTABLISHMENT COMPLETE

Change history					
TSG-RAN#	Version	CR	Tdoc RAN	New Version	Subject/Comment
RAN_08	3.2.0	294	RP-000223	3.3.0	RLC reconfiguration indicator
RAN_08	3.2.0	296	RP-000223	3.3.0	RLC Info
RAN_08	3.2.0	297	RP-000223	3.3.0	Usage of Transport CH ID
RAN_08	3.2.0	298	RP-000223	3.3.0	Transport format combination set
RAN_08	3.2.0	300	RP-000223	3.3.0	Usage of U-RNTI and C-RNTI in DL DCCH message
RAN_08	3.2.0	301	RP-000223	3.3.0	Description of Cell Update Procedure
RAN_08	3.2.0	304	RP-000223	3.3.0	System information modification procedure
RAN_08	3.2.0	305	RP-000223	3.3.0	Functional descriptions of the RRC messages
RAN_08	3.2.0	306	RP-000223	3.3.0	Clarification of CTFC calculation
RAN_08	3.2.0	307	RP-000223	3.3.0	Compressed mode parameters
RAN_08	3.2.0	309	RP-000223	3.3.0	Signalling procedure for periodic local authentication
RAN_08	3.2.0	310	RP-000223	3.3.0	Editorial corrections on security
RAN_08	3.2.0	311	RP-000223	3.3.0	Security capability
RAN_08	3.2.0	312	RP-000223	3.3.0	Corrections on ASN.1 definitions
RAN_08	3.2.0	313	RP-000223	3.3.0	DRX cycle lower limit
RAN_08	3.2.0	314	RP-000223	3.3.0	Removal of CPICH SIR measurement quantity
RAN_08	3.2.0	315	RP-000223	3.3.0	Signalling connection release request
RAN_08	3.2.0	318	RP-000223	3.3.0	Change to IMEI coding from BCD to hexadecimal
RAN_08	3.2.0	319	RP-000223	3.3.0	Removal of RLC sequence numbers from RRC initialization information
RAN_08	3.2.0	320	RP-000223	3.3.0	Addition of the length of PDCP sequence numbers into PDCP info
RAN_08	3.2.0	323	RP-000224	3.3.0	BSIC verification of GSM cells
RAN_08	3.2.0	324	RP-000224	3.3.0	Reporting cell status
RAN_08	3.2.0	325	RP-000224	3.3.0	RRC measurement filtering parameters
RAN_08	3.2.0	326	RP-000224	3.3.0	Cell-reselection parameter signalling
RAN_08	3.2.0	328	RP-000224	3.3.0	Multiplicity values
RAN_08	3.2.0	329	RP-000224	3.3.0	Quality measurements
RAN_08	3.2.0	330	RP-000224	3.3.0	CPCH Status Indication mode correction
RAN_08	3.2.0	331	RP-000224	3.3.0	End of CPCH transmission
RAN_08	3.2.0	332	RP-000224	3.3.0	Handover to UTRAN procedure
RAN_08	3.2.0	333	RP-000224	3.3.0	Harmonization of access service classes in FDD and TDD
RAN_08	3.2.0	334	RP-000224	3.3.0	Correction to usage of primary CCPCH info and primary CPICH info

Change history					
TSG-RAN#	Version	CR	Tdoc RAN	New Version	Subject/Comment
RAN_08	3.2.0	335	RP-000224	3.3.0	Corrections and clarifications on system information handling
RAN_08	3.2.0	336	RP-000224	3.3.0	Editorial corrections
RAN_08	3.2.0	337	RP-000224	3.3.0	Editorial corrections on uplink timing advance
RAN_08	3.2.0	339	RP-000224	3.3.0	Correction of Transport Format Combination tabular format and ASN.1
RAN_08	3.2.0	340	RP-000224	3.3.0	UE variables
RAN_08	3.2.0	342	RP-000224	3.3.0	General error handling
RAN_08	3.2.0	344	RP-000224	3.3.0	System Information extensibility in ASN.1 definitions
RAN_08	3.2.0	345	RP-000224	3.3.0	Usage of pilot bits
RAN_08	3.2.0	346	RP-000224	3.3.0	RRC connection release procedure
RAN_08	3.2.0	347	RP-000225	3.3.0	Alignment of Section 10.3 on methodology defined in 25.921
RAN_08	3.2.0	348	RP-000225	3.3.0	Modifications of cell (re)selection parameters
RAN_08	3.2.0	350	RP-000225	3.3.0	GPS time-of-week represented as seconds and fractions of seconds
RAN_08	3.2.0	351	RP-000225	3.3.0	CPCH corrections
RAN_08	3.2.0	352	RP-000225	3.3.0	PLMN type selection
RAN_08	3.2.0	353	RP-000225	3.3.0	Paging and establishment cause values
RAN_08	3.2.0	354	RP-000225	3.3.0	Common channel configurations
RAN_08	3.2.0	355	RP-000225	3.3.0	Clarification of prioritization of logical channels in UE
RAN_08	3.2.0	357	RP-000225	3.3.0	UE capability corrections
RAN_08	3.2.0	358	RP-000225	3.3.0	Clarification of HFN
RAN_08	3.2.0	359	RP-000225	3.3.0	Clarification of Integrity Protection
RAN_08	3.2.0	360	RP-000225	3.3.0	RRC message size optimization regarding TrCH parameters
RAN_08	3.2.0	361	RP-000225	3.3.0	Protocol extensions in ASN
RAN_08	3.2.0	362	RP-000225	3.3.0	Downloading of pre- defined configurations via SIB 16
RAN_08	3.2.0	363	RP-000225	3.3.0	Optimization of System Information
RAN_08	3.2.0	364	RP-000225	3.3.0	CPCH gain factor
RAN_08	3.2.0	368	RP-000225	3.3.0	SFN Transmission Rate in TDD Mode
RAN_08	3.2.0	371	RP-000225	3.3.0	Integrity Control
RAN_08	3.2.0	372	RP-000225	3.3.0	Modification to measurement event evaluation
RAN_08	3.2.0	373	RP-000225	3.3.0	System Information related parameters
RAN_08	3.2.0	375	RP-000226	3.3.0	Changes in RB mapping info
RAN_08	3.2.0	377	RP-000226	3.3.0	Editorial corrections to PRACH system information and Cell info

Change history					
TSG-RAN#	Version	CR	Tdoc RAN	New Version	Subject/Comment
RAN_08	3.2.0	378	RP-000226	3.3.0	Editorial Corrections to 25.331 Procedures and Tabular Format
RAN_08	3.2.0	379	RP-000226	3.3.0	Corrections to figures and procedures for the failure cases
RAN_08	3.2.0	380	RP-000226	3.3.0	Corrections on use of ORDERED_CONFIG
RAN_08	3.2.0	382	RP-000226	3.3.0	Corrections to Transport Channel and RB Reconfiguration procedures
RAN_08	3.2.0	383	RP-000226	3.3.0	Corrections to INITIAL DIRECT TRANSFER and UE CAPABILITY INFORMATION CONFIRM procedures
RAN_08	3.2.0	384	RP-000226	3.3.0	Corrections to Transparent mode signalling info Tabular format and ASN.1
RAN_08	3.2.0	385	RP-000226	3.3.0	Corrections to Soft Handover messages and procedures
RAN_08	3.2.0	387	RP-000226	3.3.0	Corrections to RRC CONNECTION REJECT procedures
RAN_08	3.2.0	388	RP-000226	3.3.0	Transport format combination in TDD and Transport channel ID
RAN_08	3.2.0	389	RP-000226	3.3.0	Signalling for dynamic TTI in TDD
RAN_08	3.2.0	390	RP-000226	3.3.0	Usage of DCCH for Shared Channel Allocation message
RAN_08	3.2.0	391	RP-000226	3.3.0	Correction to physical channel IEs in TDD
RAN_08	3.2.0	392	RP-000226	3.3.0	TDD preconfiguration for Handover to UTRAN
RAN_08	3.2.0	393	RP-000226	3.3.0	Corrections to measurement control descriptions and messages
RAN_08	3.2.0	394	RP-000226	3.3.0	Corrections on ASN.1 definitions
RAN_08	3.2.0	395	RP-000226	3.3.0	Addition of the Segmentation indication field for transparent mode RLC in the RLC Info
RAN_08	3.2.0	396	RP-000226	3.3.0	Radio Bearer identity for CCCH
RAN_08	3.2.0	397	RP-000226	3.3.0	ASN.1 definitions for RRC information between network nodes
RAN_08	3.2.0	398	RP-000227	3.3.0	NAS Routing
RAN_08	3.2.0	399	RP-000227	3.3.0	DPCCH power control preamble
RAN_08	3.2.0	400	RP-000227	3.3.0	Modifications of Assisted GPS Messages
RAN_08	3.2.0	401	RP-000227	3.3.0	Choice of Initial UE Identity
RAN_08	3.2.0	402	RP-000227	3.3.0	ANSI-41 information elements
RAN_08	3.2.0	404	RP-000227	3.3.0	RLC value ranges
RAN_08	3.2.0	408	RP-000227	3.3.0	HFN Reset
RAN_08	3.2.0	409	RP-000227	3.3.0	Clarification on ciphering parameters and integrity protection procedure in case of SRNS relocation
RAN_08	3.2.0	410	RP-000227	3.3.0	Clarification of compressed mode activation and configuration failure
RAN_08	3.2.0	412	RP-000227	3.3.0	Modification of the RLC Size IE
RAN_08	3.2.0	414	RP-000227	3.3.0	CPCH DL Power control
RAN_08	3.2.0	415	RP-000227	3.3.0	SFN measurements in TDD
RAN_09	3.3.0	356	RP-000361	3.4.0	(09/00) Clarification on multiplicity of PCH and PICH and S-CCPCH selection

Change history					
TSG-RAN#	Version	CR	Tdoc RAN	New Version	Subject/Comment
RAN_09	3.3.0	403	RP-000361	3.4.0	Parameters to be stored in the USIM
RAN_09	3.3.0	413	RP-000361	3.4.0	Optimization of Inter-system handover message
RAN_09	3.3.0	416	RP-000361	3.4.0	Timing Advance in Handover Procedures
RAN_09	3.3.0	417	RP-000361	3.4.0	Synchronization of Timing Advance and Timing Deviation Measurement
RAN_09	3.3.0	418	RP-000361	3.4.0	Downlink Physical Channels Per Timeslot
RAN_09	3.3.0	419	RP-000361	3.4.0	TDD Mode DCH Reception in Cell DCH State
RAN_09	3.3.0	420	RP-000361	3.4.0	Downlink Power Control During DTX in TDD Mode
RAN_09	3.3.0	421	RP-000361	3.4.0	Paging Indicator Length Definition
RAN_09	3.3.0	422	RP-000361	3.4.0	Updating & alignment of RRC containers & handover to UTRAN information transfer
RAN_09	3.3.0	424	RP-000361	3.4.0	Default values for UE timers and counters
RAN_09	3.3.0	425	RP-000361	3.4.0	Security mode control
RAN_09	3.3.0	426	RP-000361	3.4.0	Corrections and Editorial updates to chapter 8
RAN_09	3.3.0	427	RP-000361	3.4.0	Corrections and editorial updates to chapter 10
RAN_09	3.3.0	428	RP-000361	3.4.0	Transition from CELL_DCH to CELL_PCH and URA_PCH state
RAN_09	3.3.0	430	RP-000361	3.4.0	Assisted GPS Messaging and Procedures
RAN_09	3.3.0	431	RP-000361	3.4.0	Corrections to Activation Time use
RAN_09	3.3.0	432	RP-000361	3.4.0	Editorial Corrections to measurement reporting range
RAN_09	3.3.0	434	RP-000361	3.4.0	Default DPCH offset value and DPCH offset
RAN_09	3.3.0	435	RP-000361	3.4.0	RLC info
RAN_09	3.3.0	437	RP-000362	3.4.0	Clarification of the description of IE semantics in "RB with PDCP information"
RAN_09	3.3.0	438	RP-000362	3.4.0	Editorial corrections on security
RAN_09	3.3.0	439	RP-000362	3.4.0	Editorial correction to RB mapping info
RAN_09	3.3.0	440	RP-000362	3.4.0	Compressed mode configuration failure
RAN_09	3.3.0	441	RP-000362	3.4.0	Gain factors for TDD
RAN_09	3.3.0	442	RP-000362	3.4.0	Introduction of Default DPCH Offset Value in TDD
RAN_09	3.3.0	444	RP-000362	3.4.0	Optimization of handover to UTRAN command
RAN_09	3.3.0	445	RP-000362	3.4.0	Editorial corrections
RAN_09	3.3.0	448	RP-000362	3.4.0	Mapping of channelization code
RAN_09	3.3.0	449	RP-000362	3.4.0	DL TFCS Limitation
RAN_09	3.3.0	450	RP-000362	3.4.0	SIB offset
RAN_09	3.3.0	451	RP-000362	3.4.0	RRC CONNECTION RELEASE cause

Change history					
TSG-RAN#	Version	CR	Tdoc RAN	New Version	Subject/Comment
RAN_09	3.3.0	452	RP-000362	3.4.0	Addition of RACH TFCS
RAN_09	3.3.0	453	RP-000362	3.4.0	Cell Identity
RAN_09	3.3.0	454	RP-000362	3.4.0	Editorial Modifications
RAN_09	3.3.0	455	RP-000362	3.4.0	TDD PRACH Power Control for Spreading Factor 8/16
RAN_09	3.3.0	456	RP-000362	3.4.0	TDD CCTrCH Repetition Length Definition
RAN_09	3.3.0	457	RP-000362	3.4.0	Reporting threshold of traffic volume measurements
RAN_09	3.3.0	459	RP-000362	3.4.0	LCS GPS assistance data for SIB
RAN_09	3.3.0	461	RP-000362	3.4.0	Support of cell update confirm on CCCH
RAN_09	3.3.0	462	RP-000363	3.4.0	Max Window Size in RLC capabilities
RAN_09	3.3.0	463	RP-000363	3.4.0	UE handling of CFN
RAN_09	3.3.0	464	RP-000363	3.4.0	Correction of padding description in clause 12
RAN_09	3.3.0	465	RP-000363	3.4.0	Window size in RLC info
RAN_09	3.3.0	466	RP-000363	3.4.0	TFC Control Duration
RAN_09	3.3.0	467	RP-000363	3.4.0	System Information Block Tabular Information
RAN_09	3.3.0	469	RP-000363	3.4.0	Frequency encoding in inter-system handover messages
RAN_09	3.3.0	470	RP-000363	3.4.0	RRC message size optimization regarding TFS parameters
RAN_09	3.3.0	471	RP-000363	3.4.0	RACH selection
RAN_09	3.3.0	472	RP-000363	3.4.0	DRX cycle lower limit
RAN_09	3.3.0	474	RP-000363	3.4.0	Rx window size in RLC info
RAN_09	3.3.0	476	RP-000363	3.4.0	Corrections & optimizations regarding system information blocks of length 215..221
RAN_09	3.3.0	477	RP-000363	3.4.0	Corrections on 8.1.1 resulting from RRC review at R2#14
RAN_09	3.3.0	478	RP-000363	3.4.0	Corrections to the RRC connection release procedure
RAN_09	3.3.0	479	RP-000363	3.4.0	New release cause for signalling connection re-establishment
RAN_09	3.3.0	480	RP-000363	3.4.0	Correction to IE midamble shift and burst type
RAN_09	3.3.0	481	RP-000363	3.4.0	Correction in RLC info
RAN_09	3.3.0	483	RP-000363	3.4.0	Description of CTCH occasions
RAN_09	3.3.0	485	RP-000363	3.4.0	TDD CCTrCH UL/DL Pairing for Inner Loop Power Control
RAN_09	3.3.0	486	RP-000363	3.4.0	DCCH and BCCH Signaling of TDD UL OL PC Information
RAN_09	3.3.0	487	RP-000364	3.4.0	Broadcast SIBs for TDD UL OL PC Information
RAN_09	3.3.0	490	RP-000364	3.4.0	CPCH corrections
RAN_09	3.3.0	492	RP-000364	3.4.0	Corrections to Security IEs

Change history					
TSG-RAN#	Version	CR	Tdoc RAN	New Version	Subject/Comment
RAN_09	3.3.0	494	RP-000364	3.4.0	Corrections to parameters to be stored in the USIM
RAN_09	3.3.0	496	RP-000364	3.4.0	Editorial corrections
RAN_09	3.3.0	497	RP-000364	3.4.0	Physical Shared Channel Allocation procedure
RAN_09	3.3.0	498	RP-000364	3.4.0	Correction to Transport Format Combination Control Message
RAN_09	3.3.0	499	RP-000364	3.4.0	Usage of Cell Parameter ID
RAN_09	3.3.0	500	RP-000364	3.4.0	RB description for SHCCH
RAN_09	3.3.0	501	RP-000364	3.4.0	Use of LI in UM
RAN_09	3.3.0	502	RP-000364	3.4.0	Minor Corrections to RRC Protocol Specification
RAN_09	3.3.0	503	RP-000364	3.4.0	Correction to Cell Update Cause
RAN_09	3.3.0	504	RP-000364	3.4.0	Correction on T307 definition
RAN_09	3.3.0	505	RP-000364	3.4.0	Corrections to relative priorities in RRC Protocol
RAN_09	3.3.0	506	RP-000364	3.4.0	Unification of Reconfiguration Procedures
RAN_09	3.3.0	507	RP-000364	3.4.0	Changes to section 8.2 proposed at Paris RRC Ad Hoc
RAN_09	3.3.0	508	RP-000364	3.4.0	Establishment Cause
RAN_09	3.3.0	509	RP-000364	3.4.0	PRACH partitioning
RAN_09	3.3.0	510	RP-000364	3.4.0	Editorial Correction on Active Set Update
RAN_09	3.3.0	511	RP-000364	3.4.0	Editorial Correction regarding system information
RAN_09	3.3.0	512	RP-000365	3.4.0	Clarification on Reporting Cell Status
RAN_09	3.3.0	513	RP-000365	3.4.0	Editorial corrections on RRC Connection Establishment and Release procedures NOTE: In subclause 8.1.4.5, the change from "decrease" to "increase" for V308 was decided to be incorrect after discussion on the TSG-RAN WG2 reflector and was not implemented
RAN_09	3.3.0	514	RP-000365	3.4.0	Gated Transmission Control Info
RAN_09	3.3.0	515	RP-000365	3.4.0	Cell selection/reselection parameters for SIB 3/4
RAN_09	3.3.0	516	RP-000365	3.4.0	Implementation of Ec/N0 parameters and optimization of SIB 11/12
RAN_09	3.3.0	517	RP-000365	3.4.0	PRACH Info
RAN_09	3.3.0	518	RP-000365	3.4.0	Uplink DPCH power control info
RAN_09	3.3.0	519	RP-000365	3.4.0	AICH power offset value range
RAN_09	3.3.0	520	RP-000365	3.4.0	Direct paging of RRC connected UE in CELL_PCH/URA_PCH NOTE: This CR was postponed in TSG-RAN #9 and was wrongly included in v3.4.0. This was corrected in v3.4.1
RAN_09	3.3.0	521	RP-000365	3.4.0	Corrections to Sections 1-7
RAN_09	3.3.0	522	RP-000365	3.4.0	Error handling for Uplink Physical Channel Control procedure

Change history					
TSG-RAN#	Version	CR	Tdoc RAN	New Version	Subject/Comment
RAN_09	3.3.0	523	RP-000365	3.4.0	Corrections to downlink outer loop power control in compressed mode
RAN_09	3.3.0	524	RP-000365	3.4.0	Clarification on measurement procedure using compressed mode
RAN_09	3.3.0	525	RP-000365	3.4.0	Updates to cell and URA update procedures based on RRC Ad Hoc
RAN_09	3.3.0	526	RP-000365	3.4.0	Updates to RNTI allocation procedure based on RRC Ad Hoc
RAN_09	3.3.0	528	RP-000365	3.4.0	PRACH constant value
RAN_09	3.3.0	530	RP-000365	3.4.0	Corrections to the paging procedure
RAN_09	3.3.0	532	RP-000365	3.4.0	Moving of text from 25.304
RAN_09	3.3.0	533	RP-000365	3.4.0	Message extensibility
RAN_09	3.3.0	534	RP-000365	3.4.0	Additions to "State of RRC Procedure" in RRC Initialization information, source RNC to target RNC
RAN_09	3.3.0	535	RP-000365	3.4.0	Support of codec negotiation
RAN_09	3.4.0	-	-	3.4.1	Removal of contents of CR 520 from v3.4.0, because it was postponed at TSG-RAN #9 and by accident included anyway.