

**TSG-RAN Meeting #6  
Nice, France, 13 – 15 December 1999**

**TSGRP#6(99)748**

**Title:** Agreed CRs of category "D" (Editorial) to TS 25.415

**Source:** TSG-RAN WG3

**Agenda item:** 5.4.3

<b>Doc #</b>	<b>Status-</b>	<b>Spec</b>	<b>CR</b>	<b>Rev</b>	<b>Subject</b>	<b>Cat</b>	<b>Versio</b>	<b>Versio</b>
R3-99i98	agreed	25.415	002		Editorial corrections and clarifications	D	3.0.0	3.1.0
R3-99i99	agreed	25.415	003		Addition of definitions for transcoder	D	3.0.0	3.1.0

<b>CHANGE REQUEST</b>		<small>Please see embedded help file at the bottom of this page for instructions on how to fill in this form correctly.</small>	
<b>25.415 CR 002</b>		Current Version: <b>3.0.0</b>	
<small>GSM (AA.BB) or 3G (AA.BBB) specification number ↑</small>		<small>↑ CR number as allocated by MCC support team</small>	
For submission to: <b>TSG-RAN #6</b>	for approval <input checked="" type="checkbox"/>	strategic <input type="checkbox"/>	<small>(for SMG use only)</small>
<small>list expected approval meeting # here ↑</small>	for information <input type="checkbox"/>	non-strategic <input type="checkbox"/>	

Form: CR cover sheet, version 2 for 3GPP and SMG      The latest version of this form is available from: <ftp://ftp.3gpp.org/Information/CR-Form-v2.doc>

**Proposed change affects:**      (U)SIM       ME       UTRAN / Radio       Core Network   
(at least one should be marked with an X)

**Source:**      TSG-RAN WG3      **Date:**      27<sup>th</sup> Oct 1999

**Subject:**      Editorial corrections and clarifications

**Work item:**      \_\_\_\_\_

<b>Category:</b>	F Correction <input type="checkbox"/> A Corresponds to a correction in an earlier release <input type="checkbox"/> B Addition of feature <input type="checkbox"/> C Functional modification of feature <input type="checkbox"/> D Editorial modification <input checked="" type="checkbox"/>	<b>Release:</b>	Phase 2 <input type="checkbox"/> Release 96 <input type="checkbox"/> Release 97 <input type="checkbox"/> Release 98 <input type="checkbox"/> Release 99 <input checked="" type="checkbox"/> Release 00 <input type="checkbox"/>
------------------	--	-----------------	--

(only one category shall be marked with an X)

**Reason for change:**      This CR proposes editorial corrections and clarifications to 25.415 v 3.0.0.

**Clauses affected:**      All clauses are effected

<b>Other specs affected:</b>	Other 3G core specifications <input type="checkbox"/> Other GSM core specifications <input type="checkbox"/> MS test specifications <input type="checkbox"/> BSS test specifications <input type="checkbox"/> O&M specifications <input type="checkbox"/>	→ List of CRs: _____ → List of CRs: _____ → List of CRs: _____ → List of CRs: _____ → List of CRs: _____
------------------------------	---	--

**Other comments:**      Was R3-99F78 at RAN3 #8 lu SWG



<----- double-click here for help and instructions on how to create a CR.

# Contents

Intellectual Property Rights .....	7
Foreword .....	7
1 Scope.....	8
2 References .....	8
3 Definitions, symbols and abbreviations.....	8
3.1 Definitions .....	8
3.2 Abbreviations.....	9
3.3 Concepts .....	10
4 General.....	10
4.1 General aspects .....	10
4.2 Operational and Functional aspects .....	11
4.2.1 Iu UP protocol modes of operation .....	11
4.2.2 Transparent mode (TrM).....	11
4.2.3 Support mode .....	12
5 Transparent mode .....	13
5.1 General.....	13
5.1.1 Operation of the Iu UP in Transparent mode .....	13
5.1.2 Interfaces of the Iu UP protocol layer in Transparent mode .....	13
5.2 Iu UP Protocol layer Services in Transparent mode .....	13
5.3 Services Expected from the UP Data Transport layer.....	13
5.4 Elements for Iu UP communication in Transparent mode .....	14
5.4.1 Frames Format for transparent .....	14
6 Support mode .....	14
6.1 General.....	14
6.1.1 Operation of the Iu UP in Support mode.....	14
6.1.2 Interfaces of the Iu UP protocol layer in Support mode .....	14
6.2 Iu UP Protocol layer Services in Support mode.....	15
6.3 Services Expected from the UP Data Transport layer.....	15
6.4 Functions of the Iu UP Protocol Layer in Support mode .....	15
6.4.1 Functional model of the Iu UP Protocol Layer in Support mode .....	15
6.4.2 Frame Handler function.....	16
6.4.3 Procedure Control functions.....	16
6.4.4 Non Access Stratum Data Streams specific function(s) .....	16
6.4.4.1 Frame Quality Classification function .....	16
6.4.4.1.1 General.....	16
6.4.4.1.2 Handling of FQC information .....	17
6.5 Elementary procedures.....	18
6.5.1 General.....	18
6.5.2 Transfer of User Data procedure.....	18
6.5.2.1 Successful operation .....	18
6.5.2.2 Unsuccessful operation.....	19
6.5.3 Initialisation procedure.....	20
6.5.3.1 Successful operation .....	20
6.5.3.2 Unsuccessful operation.....	21
6.5.4 Iu Downlink Rate Control procedure .....	21
6.5.4.1 Successful operation .....	21
6.5.4.2 Unsuccessful operation.....	22
6.5.5 Time Alignment procedure (FFS) .....	22
6.5.6 Handling of Abnormal Event procedure (TBD).....	22
6.5.7 Frame Quality Classification.....	23
6.6 Elements for Iu UP communication in Support mode.....	23
6.6.1 Frames Format for predefined size SDUs .....	23

6.6.1.1	PDU Type 0.....	23
6.6.1.2	PDU Type 1.....	24
6.6.1.3	PDU Type 15.....	24
6.6.1.3.1	General.....	24
6.6.1.3.2	Positive Acknowledgement.....	25
6.6.1.3.3	Negative Acknowledgement .....	26
6.6.1.3.4	Procedures Coding .....	26
6.6.1.3.4.1	Initialization .....	26
6.6.1.3.4.2	Rate Control .....	27
6.6.1.3.4.3	Time Alignment (FFS) .....	28
6.6.1.3.4.4	Abnormal Event (TBD).....	28
6.6.2	Frames content definition and Frames coding.....	28
6.6.2.1	Frame Number.....	28
6.6.2.2	PDU Type 15 Frame Number.....	28
6.6.2.3	PDU Type.....	28
6.6.2.4	RAB sub-Flow Combination Indicator (RFCI).....	28
6.6.2.5	Ack/Nack.....	29
6.6.2.6	Procedure Indicator .....	29
6.6.2.7	PDU type 0 Header CRC.....	29
6.6.2.8	PDU type 0 Payload CRC .....	29
6.6.2.9	PDU type 1 Header CRC.....	29
6.6.2.10	PDU type 15 Header CRC.....	29
6.6.2.11	PDU type 15 Payload Check Sum .....	29
6.6.2.12	Chain Indicator .....	30
6.6.2.13	Number of Subflows.....	30
6.6.2.14	Length Indicator (LI).....	30
6.6.2.15	Number of RFCIs Indicator .....	30
6.6.2.16	RFCI Indicator.....	30
6.6.2.17	Frame Quality Classification (FQC).....	30
6.6.2.18	Cause Indicator.....	30
6.6.3	Timers .....	31
6.7	Handling of unknown, unforeseen and erroneous protocol data.....	31
7	Communication Primitives for the Iu UP protocol layer.....	31
7.1	Modelling Principle .....	31
7.2	Primitives towards the upper layers at the RNL SAP .....	31
7.2.1	General.....	31
7.2.2	Iu-UP-DATA-REQUEST .....	33
7.2.3	Iu-UP-DATA-INDICATION.....	33
7.2.4	Iu-UP-STATUS-REQUEST .....	33
7.2.5	Iu-UP-STATUS-INDICATION.....	33
7.2.6	Iu-UP-UNIT-DATA-REQUEST.....	33
7.2.7	Iu-UP-UNIT-DATA-INDICATION.....	33
7.3	Primitives towards the transport layers at TNL SAP .....	34
7.3.1	General.....	34
7.3.2	Primitives at the TNL-SAP with ATM/AAL2 Transport layer .....	34
7.3.3	AAL2 Service Primitives used by the Iu UP protocol.....	34
7.3.4	Primitives at the TNL-SAP with GTP-U Transport Layer .....	34
7.3.5	Generic Service Primitives used by the Iu UP protocol .....	34
Annex A (Informative):	Illustration of usage of RFCI for AMR speech RAB. ....	36
Annex B (Informative):	Illustration of protocol states in the Iu UP.....	39
B.1	Protocol state model for transparent mode .....	39
B.1.1	Null State.....	40
B.1.2	Transparent Mode Data Transfer Ready State .....	40
B.2	Protocol state model for support mode for predefined SDU sizes.....	41
B.2.1	Null State.....	42
B.2.2	Initialisation State.....	42
B.2.3	Support Mode Data Transfer Ready State.....	43
B.2.4	Abnormal Event State (TBD).....	43

Annex C (Informative): Open Issues of the Iu UP..... 44  
History..... 45

---

## Intellectual Property Rights

IPRs essential or potentially essential to the present deliverable may have been declared to 3GPP and/or its organizational partners. The information pertaining to these essential IPRs, if any, is publicly available for **3GPP members and non-members, free of charge**. This can be found in the latest version of the 3GPP Technical Report:

[reference tbd.]

Pursuant to the 3GPP Interim IPR Policy, no investigation, including IPR searches, has been carried out by 3GPP. No guarantee can be given as to the existence of other IPRs not referenced in the [tbd.], which are, or may be, or may become, essential to the present document.

---

## Foreword

This Technical Specification has been produced by the 3<sup>rd</sup> Generation Partnership Project, Technical Specification Group RAN WG3.

The contents of this TS may be subject to continuing work within the 3GPP and may change following formal TSG approval. Should the TSG modify the contents of this TS, it will be re-released with an identifying change of release date and an increase in version number as follows:

Version m.t.e

where:

- m indicates [major version number]
- x the second digit is incremented for all changes of substance, i.e. technical enhancements, corrections, updates, etc.
- y the third digit is incremented when editorial only changes have been incorporated into the specification.

---

## Scope

This Technical Specification defines the Radio Network Layer user plane protocol being used over the Iu interface.

---

## References

The following documents contain provisions, which, through reference in this text, constitute provisions of the present document.

- References are either specific (identified by date of publication, edition number, version number, etc.) or non-specific.
- For a specific reference, subsequent revisions do not apply.
- For a non-specific reference, the latest version applies.
- A non-specific reference to an ETS shall also be taken to refer to later versions published as an EN with the same number.

- [1] UMTS 25.401, 3<sup>rd</sup> Generation Partnership Project (3GPP) Technical Specification Group (TSG) RAN; UTRAN Overall Description
  - [2] UMTS 25.410, 3<sup>rd</sup> Generation Partnership Project (3GPP) Technical Specification Group (TSG) RAN; UTRAN Iu interface: general Aspects and Principles
  - [3] UMTS 25.413, 3<sup>rd</sup> Generation Partnership Project (3GPP) Technical Specification Group (TSG) RAN; UTRAN Iu interface RANAP protocol
  - [4] UMTS 25.414, 3<sup>rd</sup> Generation Partnership Project (3GPP) Technical Specification Group (TSG) RAN; Iu Interface Data Transport and Transport Signalling
  - [5] UMTS 23.110, 3<sup>rd</sup> Generation Partnership Project (3GPP) Technical Specification Group (TSG) SSA, UMTS Access Stratum, services and functions
  - [6] UMTS 23.121, 3<sup>rd</sup> Generation Partnership Project (3GPP) Technical Specification Group (TSG) SSA, Architectural requirements for Release 99
  - [7] ITU-T Recommendation I.363.2 (1997) - B-ISDN ATM Adaptation Layer type 2 specification
  - [8] ITU-T Recommendation I.366.1 (1998) - Segmentation and reassembly service specific convergence sublayer for the AAL type 2
  - [9] ~~UTRAN Vocabulary~~ [UMTS 25.990, 3<sup>rd</sup> Generation Partnership Project \(3GPP\) Technical Specification Group \(TSG\) RAN; Vocabulary](#)
  - [10] [UMTS 25.321, 3<sup>rd</sup> Generation Partnership Project \(3GPP\) Technical Specification Group \(TSG\) RAN; MAC Protocol Specification](#)
  - [11] [UMTS 25.322, 3<sup>rd</sup> Generation Partnership Project \(3GPP\) Technical Specification Group \(TSG\) RAN; RLC Protocol Specification](#)
- 

## Definitions, symbols and abbreviations

### Definitions

For the purposes of the present document, the following terms and definitions apply.

**Non Access Stratum (NAS) Data Streams:**

Non Access Stratum Data Streams is a generic term to identify ~~in the CN and the Terminal domains~~, these data streams exchanged at the Dedicated Service Access Points between the Non Access Stratum and the Access Stratum.

**RAB sub-flows:** A RAB as defined in [9] is realised by UTRAN through one to several sub-flows. These sub-flows correspond to the NAS service data streams that have QoS characteristics that differ in a predefined manner within a RAB e.g. different reliability classes.

RAB sub-flows characteristics:

1. The sub-flows of a RAB are established and released together at the RAB establishment and release, respectively
2. The sub-flows of a RAB are submitted and delivered together at the RAB SAP
3. The sub-flows of a RAB are carried over the same Iu transmission connection
4. The sub-flows of a RAB are organised in a predefined manner at the RAB SAP and over the Iu interface. The organisation is imposed by the NAS as part of its co-ordination responsibility.

RAB sub-flows numbering (applies to support mode for predefined SDU size only):

1. RAB sub-flows are numbered from 1 to N (N is the number of sub-flows)
2. RAB sub-flow number 1 corresponds to the highest reliability class and the RAB sub-flow number N corresponds to the lowest reliability class.

Note: It is FFS whether numbering of subflows can be based on something else than reliability classes.

3. RAB sub-flows order inside the Iu frame is predefined so that RAB sub-flow number one comes first and the RAB sub-flow number N comes last.

**RAB sub-Flow Combination (RFC):** A RAB sub-flow combination is defined as an authorised combination of the RAB sub-flows variable attributes (e.g. SDU sizes) of currently valid RAB sub-flows that can be submitted simultaneously to the Iu UP for transmission over Iu interface. Each combination is given by the CN and cannot be altered by the SRNC.

**RAB sub-Flow Combination Indicator (RFCI):** This indicator uniquely identifies a RAB sub-flow combination for the duration of the Iu UP peer protocol instances i.e. it is valid until the termination of the call or until a new initialisation is performed. Usage of RFCI applies only to Iu UP protocol operated in support mode for predefined SDU size.

Principles related to RFCI allocation and initialization procedure: :

1. RFCI value is present in every Iu user frame
2. In the ~~Initialization~~Initialisation procedure in Iu UP, the size of every RAB sub-flow SDU for each RFCI is signalled

## Abbreviations

AMR:	Adaptive Multi-Rate codec
AS:	Access Stratum
CN:	Core Network
<u>DTX:</u>	<u>Discontinuous Transmission</u>
NAS:	Non Access Stratum
QoS:	Quality of Service
PDU:	Protocol Data Unit
PCE:	Procedure Control Extension
PME:	Procedure Control Bitmap Extension
RAB:	Radio Access Bearer
RANAP:	Radio Access Network Application Part
RFC:	RAB sub Flow Combination
RFCI:	RFC Indicator
RNL:	Radio Network Layer
SAP:	Service Access Point
<u>SDU</u>	<u>Service Data Unit</u>
SMpSDU:	Support Mode for predefined SDU size
<u>SRNC</u>	<u>Serving RNC</u>
<u>SRNS</u>	<u>Serving RNS</u>



SSSAR: Service Specific Segmentation And Reassembly

TFI: Transport Format Identification

TFO: Tandem Free Operation

TNL: Transport Network Layer

TrFO: Transcoder Free Operation

TrM: Transparent Mode

UP: User Plane

UUI: User to User Information

## Concepts

### Iu UP mode of operation:

One objective of the Iu User Plane (UP) protocol is to remain independent of the CN domain (Circuit Switched or Packet Switched) and to have limited or no dependency with the Transport Network Layer. Meeting this objective provides the flexibility to evolve services regardless of the CN domain and to migrate services across CN domains.

The Iu UP protocol is therefore defined with modes of operation that can be activated on a RAB basis rather than on a CN domain basis or (tele)service basis. The Iu UP mode of operation determines if and which set of features shall be provided to meet e.g. the RAB QoS requirements.

### Iu UP protocol PDU Type:

The Iu UP protocol PDU Types are defined for a given Iu UP mode of operation. An Iu UP PDU Type represents a defined structure of an Iu UP protocol frame. For instance, a frame made of a certain Frame Header mask part and a Frame Payload part would be specified as a certain PDU type valid for a given Iu UP mode of operation.

---

## General

### General aspects

The Iu UP protocol is located in the User plane of the Radio Network layer over the Iu interface: the Iu UP protocol layer.

The Iu UP protocol is used to convey user data associated to Radio Access Bearers.

One Iu UP protocol instance is associated to one RAB and one RAB only. If several RABs are established towards one given UE, then these RABs make use of several Iu UP protocol instances.

Iu UP protocol instances exist at Iu access point as defined [2] i.e. at CN and UTRAN. Whenever a RAB requires transfer of user data in the Iu UP, an Iu UP protocol instance exists at each Iu interface access points. These Iu UP protocol instances are established, relocated and release together with the associated RAB.

Whether these peer protocol instances perform some RAB related function depends on the mode of operation of the Iu UP as defined below.

The following figure illustrates the logical placement of the Iu UP protocol layer and the placement of the Data Streams sources outside of the Access Stratum.

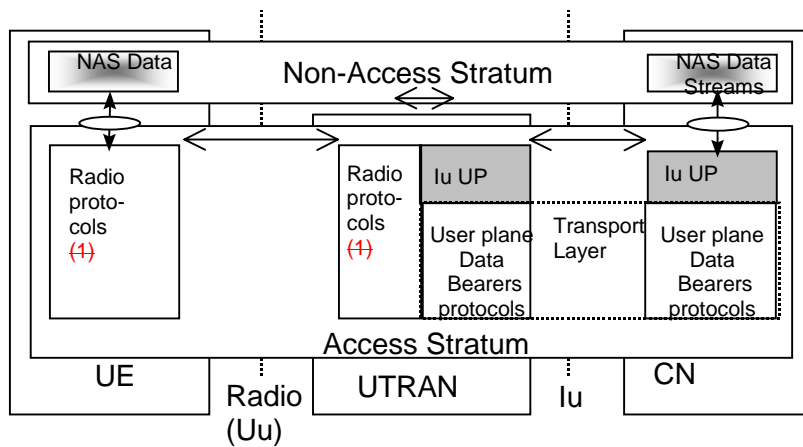

Figure 1: Iu UP protocol layer occurrence in UTRAN overall architecture (User Plane View)

## Operational and Functional aspects

### Iu UP protocol modes of operation

The Iu UP protocol operates in mode according to the concept described in earlier section.

Modes of operation of the protocol are defined:

1. Transparent mode (TrM)
2. Support mode for predefined SDU size (SMpSDU)

Determination of the Iu UP protocol instance mode of operation is a CN decision taken at RAB establishment based on e.g. the RAB characteristics. It is signalled in the Radio Network layer control plane at RAB ~~assignment~~assignment and relocation for each RAB. It is internally indicated to the Iu UP protocol layer at user plane establishment.

The choice of a mode is bound to the nature of the associated RAB and cannot be changed unless the RAB is changed.

### Transparent mode (TrM)

The transparent mode is intended for those RABs that do not require any particular feature from the Iu UP protocol other than transfer of user data.

The following figure illustrates the transparent mode of operation of the Iu UP protocol layer:

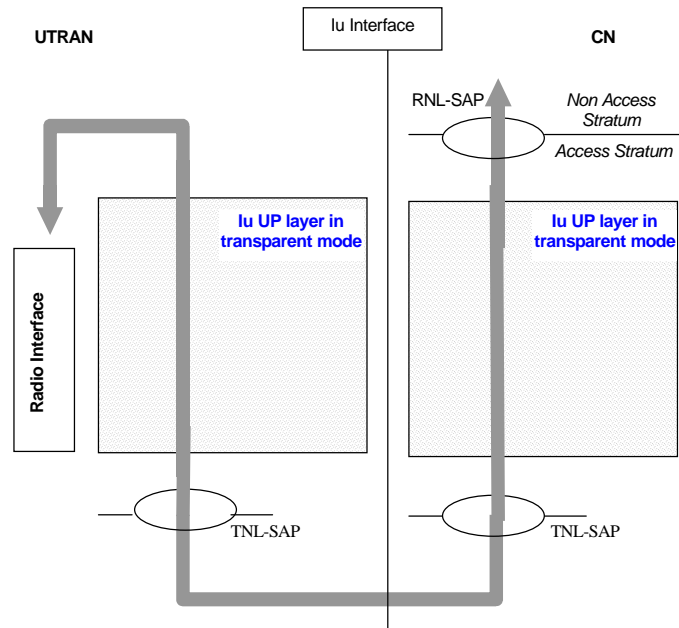

Figure 2: Iu UP protocol layer in transparent mode occurrence over Iu interface

In this mode, the Iu UP protocol instance does not perform any Iu UP protocol information exchange with its peer over the Iu interface: no Iu frame is sent. The Iu UP protocol layer is crossed through by PDUs being ~~exchanged~~ exchanged between upper layers and transport network layer.

For instance, the transfer of GTP-U PDUs or Non Transparent CS data could utilise the transparent mode of the Iu UP protocol.

### Support mode

The support modes are intended for those RABs that do require particular features from the Iu UP protocol in addition to transfer of user data. When operating in a support mode, the peer Iu UP protocol instances exchange Iu UP frames whereas in transparent mode, no Iu UP frames are generated.

The following figure illustrates the functional model of the Iu UP protocol layer in support mode of operation:

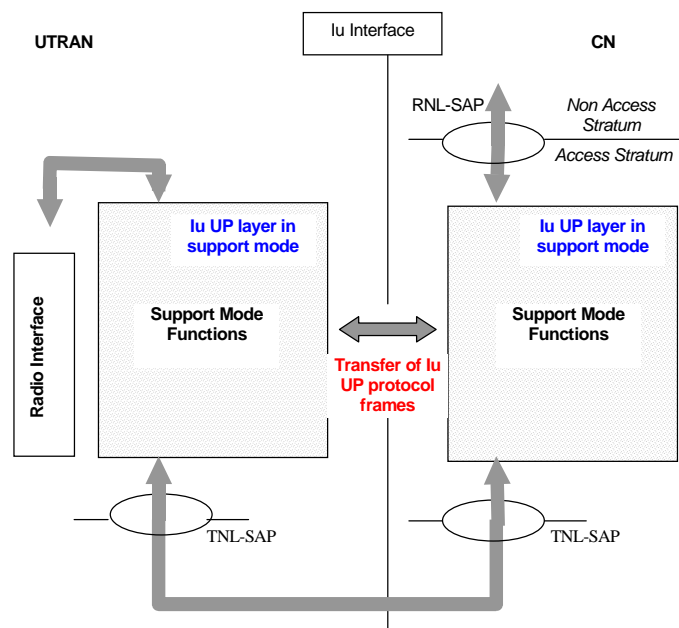

Figure 3: Iu UP protocol layer in support mode occurrence over Iu interface

Some RABs requesting Iu UP protocol support, constrain the Iu UP protocol and possibly the radio interface protocols in specific ways. For instance, certain RABs can have variable predefined rates, ~~while other RABs can have totally variable rates within a range, as signalled in the RNL control plane.~~

~~The Iu UP support and the usage of the radio interface protocols for these kinds of RABs differ significantly. Consequently,~~ The Iu UP support mode is prepared to support variations.

The only ~~support~~ support mode defined here is the:

~~+~~Support mode for predefined SDU size (SMpSDU)

For instance, the transfer of AMR speech PDUs would utilise the support mode for predefined SDU size of the Iu UP protocol because it requires some procedure control functions and some data streams specific functions while the sizes of the user data being transferred can vary in a predefined manner.

~~The choice of a support mode is bound to the nature of the associated RAB and cannot be changed unless the RAB is changed.~~

## 1 Transparent mode

### 1.1 General

#### 1.1.1 Operation of the Iu UP in Transparent mode

The Iu UP layer in Transparent mode is present in the Iu User plane for transferring data transparently over the Iu interface.

The two strata communicate through a Service Access Point for Non Access Stratum (NAS) Data Streams transfer.

#### Interfaces of the Iu UP protocol layer in Transparent mode

Interfaces of the Iu UP protocol layer in transparent mode are the transport network layer and the upper layers. The Iu UP protocol layer in Transparent Mode is an empty layer through which NAS Data Streams PDUs are crossing between the Transport Network Layer and upper layers.

The Iu UP protocol layer in transparent mode is using services of the Transport layers in order to transfer the Iu UP PDUs over the Iu interface.

### Iu UP Protocol layer Services in Transparent mode

The following functions are needed to support this mode:

- Transfer of user data

### Services Expected from the UP Data Transport layer

The Iu UP protocol layer in Transparent mode expects the following services from the Transport Network Layer:

- Transfer of user data

## 1.2 Elements for Iu UP communication in Transparent mode

### 1.2.1 Frames Format for transparent mode

The following shows the format of the PDU crossing the Iu UP protocol layer in transparent mode. This frame is transferred transparently between the Iu UP protocol upper layers and transport network layer (TNL-SAP).

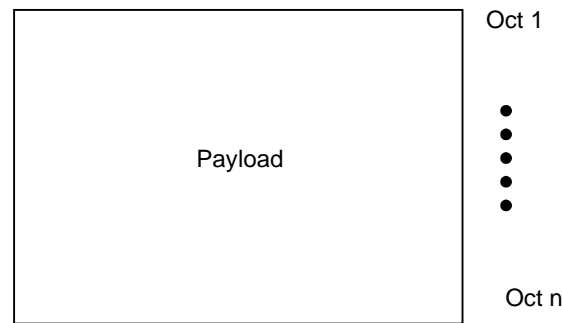

Figure 4: Frame format for transparent mode

This PDU has a variable length of n octets, whose maximum range depends on the type of user data (e.g. IP packet, Non Transparent CS data etc..). No explicit length indication is visible at the Iu UP protocol layer.

## Support mode

### General

#### Operation of the Iu UP in Support mode

The Iu UP protocol layer in Support mode is present for data streams that need frame handling in the UP.

The two strata communicate through a Service Access Point for Non Access Stratum (NAS) Data Streams transfer. There can be one or several data streams towards one Iu UP protocol instance. These non access stratum data streams need to be co-ordinated in the Non Access Stratum.

#### Interfaces of the Iu UP protocol layer in Support mode

As part of the Access Stratum responsibility, the Iu UP protocol layer in support mode provides the services and functions that are necessary to handle non access stratum data streams. The Iu UP protocol layer in support mode is providing these services to the UP upper layers through a Dedicated Service Access Point used for Information Transfer as specified in [5].

The Iu UP protocol layer in support mode is using services of the Transport layers in order to transfer the Iu UP PDUs over the Iu interface.

## Iu UP Protocol layer Services in Support mode

- **Support mode for predefined SDU size Service**

The following functions are needed to support this mode:

- Transfer of user data
- Initialisation
- Rate Control
- Time Alignment (FFS)
- Handling of abnormal event (TBD)
- Frame Quality Classification

## Services Expected from the UP Data Transport layer

The Iu UP protocol layer expects the following services from the Transport Network Layer:

- Transfer of user data

## Functions of the Iu UP Protocol Layer in Support mode

### Functional model of the Iu UP Protocol Layer in Support mode

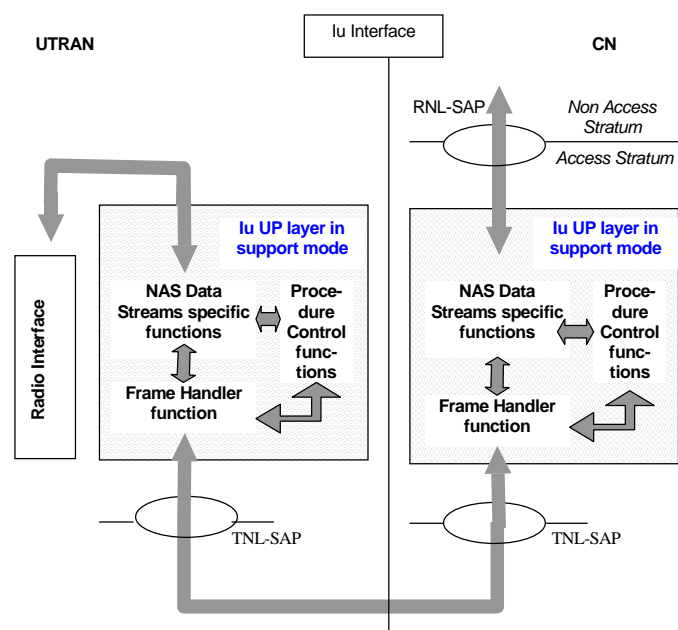

Figure 54: Functional model of the Iu UP protocol layer in Support mode

The Iu UP protocol layer in Support mode is made of three sets of functions:

1. Frame Handler function
2. Procedure Control functions
3. Non Access Stratum Data Streams specific functions.

## Frame Handler function

This function is responsible for framing and de-framing the different parts of an Iu UP protocol frame. This function takes the different parts of the Iu UP protocol frame and sets the control part field to the correct values. It also ensures that the frame control part is semantically correct. This function is responsible for interacting with the Transport layers. This function is also responsible for the CRC check of the Iu UP frame header.

## Procedure Control functions

This set of functions offers the control of a number of procedures handled at the Iu UP protocol level. These functions are responsible for the procedure control part of the Iu UP frames.

Namely, these procedures are:

- **Rate Control:** is the procedure which controls over the Iu UP the set of permitted downlink rates among the rates that can be controlled by UTRAN. The set of rates is represented by an RFCI bitmap. The function controlling this procedure interacts with functions outside of the Iu UP protocol layer.
- **Initialisation:** is the procedure which controls the exchange of initialisation information that is required for operation in support mode for predefined SDU size. Such information can contain the RFCI Set to be used until termination of the connection or until the next initialisation procedure.
- **Time Alignment (FFS):** is the procedure that controls the information exchanged over the Iu related to the sending time of Iu UP frames. The function controlling this procedure interacts with functions outside of the Iu UP protocol layer.
- **Handling of Abnormal Event (TBD):** is the procedure that controls the information exchanged over the Iu related to detection of a fault situation. The function controlling this procedure interacts with functions outside of the Iu UP protocol layer.

## Non Access Stratum Data Streams specific function(s)

These functions are responsible for a “limited” manipulation” of the payload and the consistency check of the frame number. If a frame loss is detected due to a gap in the sequence of the received frame numbers, this shall be reported to the procedure control function. These functions are responsible for the CRC check and calculation of the Iu UP frame payload part. These functions are also responsible for the Frame Quality Classification handling as described below.

These functions interact with the upper layers ~~through a SAP~~ by exchanging Iu data stream blocks of Iu UP frame payload.

These functions interact with the procedure control functions.

These functions provide service access to the upper layers for the procedure control functions.

## Frame Quality Classification function

### General

On the Iu UP in Support Mode the frames are classified with the Frame Quality Classifier (FQC). This classifying is based on the radio frame classification and the setting of the RAB attributes ‘Delivery of erroneous SDUs’. The RAB attribute ‘Delivery of erroneous SDUs’ tells if erroneous frames shall be delivered or not.

Figure 5 below shows the main input and output information for frame quality classification function on the Iu UP.

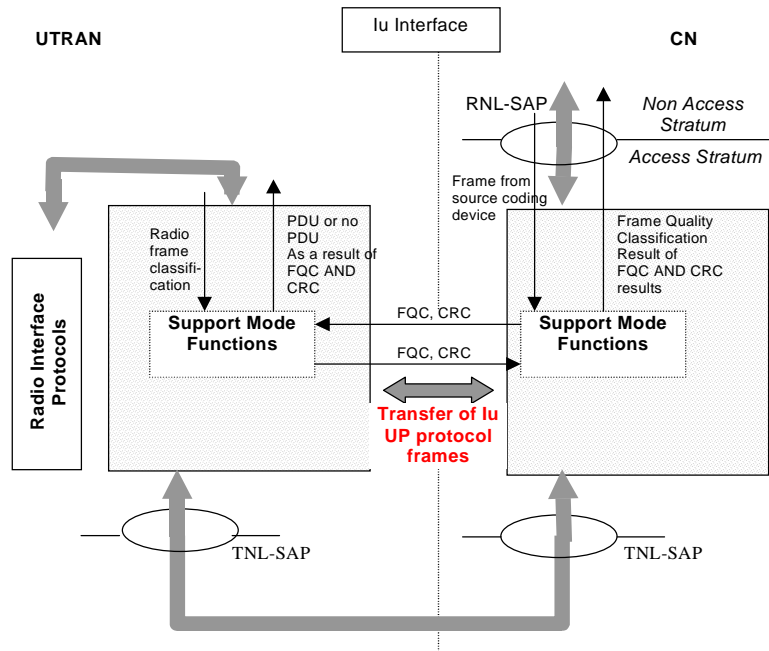

Figure 65: Frame quality classification in Iu UP

### Handling of FQC information

In SRNC on the sending side, the Support Mode Functions takes as input the radio frame quality information together with the frame. Based on this, the FQC is set for the frame, a CRC is added, if needed and the frame is sent to CN. The following table shows the FQC field setting:

INPUT		ACTION
Delivery of erroneous SDUs	Radio Frame Classification	Action taken in SRNC on the sending side
Yes	Bad	Set FQC to 'bad'
No	Bad	Drop frame
Not Applicable	Any value	Set FQC to good
Any value	Good	Set FQC to good

The Support Mode Functions in CN on the receiving side makes a CRC check of the frame payload, if CRC is present and passes the frame and the frame quality classification information through the RNL-SAP.



INPUT		ACTION
Delivery of erroneous SDUs	Payload CRC check result	Actions taken at CN on the receiving side
Yes	Not OK	Frame forwarded with FQC set to 'bad'
No	Not OK	Drop frame, send Iu-UP-Status primitive indicating 'No data' at the RNL-SAP
Not Applicable	Any result	Frame forwarded with FQC as set by UTRAN
Any value	OK	Frame forwarded with FQC as set by UTRAN

The Support Mode Functions in CN on the sending side adds a CRC, if necessary to the frame payload and passes it together with the FQC (in the transcoded case always set to good).

The Support Mode Functions in SRNC then makes a CRC-check, if CRC present. Based on the received FQC and eventually the CRC check, decision is made whether to deliver the frame or not.

INPUT			ACTION
Delivery of erroneous SDUs	FQC	CRC check (if payload CRC present)	Actions taken at SRNC on the receiving side
Yes	Bad	Any result	Drop frame
No	Bad	Any result	Drop frame
Yes	Any value	Not OK	Drop frame
No	Any value	Not OK	Drop frame
N/A	Any value	Any result	Pass the frame to radio interface protocols
Any value	Good	OK	Pass the frame to radio interface protocols

**Note:** The case where SRNC receives a frame with the FQC set to bad, corresponds to a TFO or TrFO case. The frame is then trashed by the receiving RNC since there is currently no means to pass down to the UE the frame quality indicator.

## Elementary procedures

### 6.5.1 General

~~It shall be possible to perform any of the control procedures regardless of the user data transmission.~~

### 6.5.2 Transfer of User Data procedure

#### 6.5.2.1 Successful operation

The purpose of the transfer of user data procedure is to transfer Iu UP frames between the two Iu UP protocol layers at both ends of the Iu interface. Since an Iu UP instance is associated to a RAB and a RAB only, the user data being transferred only relate to the associated RAB.

The procedure is controlled at both ends of the Iu UP instance i.e. SRNC and the CN.

The transfer of user data procedure is invoked whenever user data for that particular RAB needs to be sent ~~across~~ across the Iu interface.

The procedure is invoked by the Iu UP upper layers upon reception of the upper layer PDU and associated control information: RFCI.

In SRNC, the upper layers may deliver a frame quality classification information together with the RFCI.

The NAS Data streams functions perform, if needed, CRC calculation of the ~~upper~~ upper layer PDU and passes down to the frame handler together with the RFCI.

The frame handler function retrieves the frame number from its internal memory, format the frame header and frame payload into the appropriate PDU Type and sends the Iu UP frame PDU to the lower layers for transfer across the Iu interface.

Upon reception of a user data frame, the Iu UP protocol layer checks the consistency of the Iu UP frame as follows:

- The Frame handler checks the consistency of the frame header. If correct, the frame handler stores the frame number and passes the Iu UP frame payload and associated CRC, if any to the NAS Data Streams functions. The received RFCI is passed to the Procedure Control Function.
- The NAS Data Streams functions check the payload CRC, if any. If the RFCI is correct and matches the Iu UP frame payload as indicated by the Procedure Control functions, the NAS Data Streams forwards to the upper layers RFCI and Iu UP frame payload.

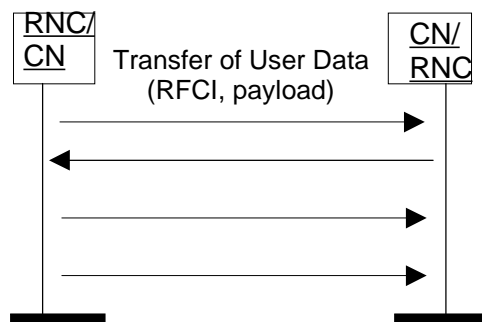

Figure 76. Successful Transfers of User Data

### 6.5.2.2 Unsuccessful operation

If the Iu UP frame carrying the user data is ~~incorrectly~~ incorrectly formatted or cannot be correctly treated by the receiving Iu UP protocol layer, the Iu UP protocol layer shall either discard the frame or pass it to the upper layers with a frame classification indicating a corrupted frame. This decision is based on configuration data of the Iu UP instance for that particular RAB (i.e. if the RAB requests delivery of corrupted frame)..

If the Iu UP protocol layer detects a frame loss because of a gap in the received frame number sequence while the frame number does not relate to time (see section Time Alignment), the receiving Iu UP protocol layer shall report ~~this~~ this to the procedure control function.

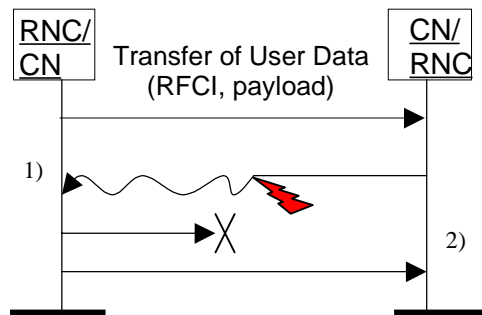

Figure 87. Unsuccessful Transfers of User Data: 1) Corrupted Frame, 2) Detection of Frame loss

## 6.5.3 Initialisation procedure

### 6.5.3.1 Successful operation

This procedure is mandatory for RABs using the support mode for predefined SDU size. The purpose of the initialisation procedure is to configure both termination points of the Iu UP with the RFCIs and associated RAB Sub Flows SDU sizes necessary during the transfer of user data phase. Additional parameters may also be passed.

The initialisation procedure is always controlled by the entity in charge of establishing the Radio Network Layer User Plane i.e. SRNC.

The initialisation procedure is invoked whenever indicated by the Iu UP Procedure Control function e.g. as a result of a relocation of SRNS or at RAB establishment over Iu.

When this procedure is invoked all other Iu UP procedures are suspended until termination of the initialisation procedure.

The SRNC allocates an RAB sub-Flow Combination indicator (RFCI) to each RAB sub-Flow Combination (RFCI). The association of indicators to RAB Flow Combinations is valid in the Iu UP until a new initialisation procedure is performed or the connection is terminated.

The procedure control function may also generate additional Iu UP protocol parameters necessary for the RAB service to operate properly over Iu.

To each RAB sub-Flow combination indicator is associated the size of each RAB sub-Flow SDU of that combination. The list of RAB Flow Combination Indicators and their respective SDU sizes constitutes the RAB sub-Flow Combination set passed over the Iu UP in the initialisation frame i.e. into an appropriate Iu UP PDU Type.

The first RAB sub-Flow Combination proposed in the list of RAB sub-Flow Combination indicates the initial RAB sub-Flow Combination i.e. the first RAB sub-Flow Combination to be used when starting the communication phase i.e. the transfer of user data procedure.

The complete set of information is framed by the Iu UP Frame Handler function and transferred in an Iu UP initialisation frame. If needed, the initialisation frame CRC is calculated and set accordingly in the respective frame field.

A supervision timer  $T_{INIT}$  is started after sending the Iu UP initialisation frame. This timer supervises the reception of the initialisation acknowledgmentacknowledgement frame.

Upon reception of a frame indicating that an initialisation control procedure is active in the peer Iu UP entity, the Iu UP protocol layer forwards to the upper layers the RAB sub-Flow Combination set to be used by the Control procedure function. It also stores the RAB sub-Flow Combination set in order to control during the transfer of user data, that the Iu UP payload is correctly formatted (e.g. RFCI matches the expected Iu UP frame payload total length).

If the initialisation frame is correctly formatted and treated by the receiving Iu UP protocol layer, this latter sends an initialisation acknowledgmentacknowledgement frame.

Upon reception of an initialisation acknowledgmentacknowledgement frame, the Iu UP protocol layer in the SRNC stops the supervision timer  $T_{INIT}$ .

If the initialisation procedure requires that several frames are to be sent, each frame shall be acknowledged individually.

If several initialisation frames are used for the initialisation procedure, the next frame shall wait for the acknowledgement of the previous frame to be received before sending. The supervision timer is used individually for each frame in a chain.

The frame number is always set to zero for the first frame in a chain and it shall be incremented in the sending direction for each sent frame. The acknowledgement or negative acknowledgement carries the frame number of the frame being acknowledged.

Upon reception of an initialisation negative acknowledgmentacknowledgement frame or at timer  $T_{INIT}$  expiry, the Iu UP protocol layer in the SRNC shall reset and restart the  $T_{INIT}$  supervision timer and repeat an initialisation frame. The repetition can be performed  $n$  times,  $n$  being chosen by the operator (default  $n=3$ ).

Consequently, when in the communication phase (as indicated by internal functions in the Radio Network layer), the frame transmission starts in downlink in the initial RFCI.

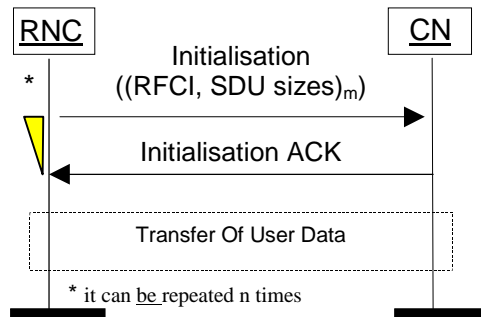

Figure 98: Successful Initialisation of Iu UP for m RFCIs

### 6.5.3.2 Unsuccessful operation

If the initialisation frame is **incorrectly** formatted and cannot be correctly treated by the receiving Iu UP protocol layer, this latter sends an initialisation negative **acknowledgement** frame.

If after n repetition, the initialisation procedure is **unsuccessfully** terminated (because of n negative **acknowledgement** or timer  $T_{INIT}$  **expires**), the Iu UP protocol layers (sending and receiving) take the appropriate actions (Abnormal Event is TBD).

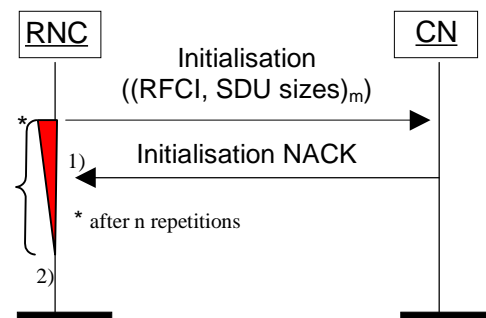

Figure 109: **Unsuccessful** initialisation of Iu UP: 1) n negative **acknowledgement** or 2) n timer **expires**

**Note of the editor:** The case where an SRNC receives an Iu frame indicating that an initialisation procedure is active at the other end of the Iu UP could be related to a TFO or TrFO negotiation. How TFO or TrFO protocol and codec negotiation is performed is FFS.

## 6.5.4 Iu Downlink Rate Control procedure

### 6.5.4.1 Successful operation

The purpose of the rate control procedure is to signal in the uplink direction to the peer Iu UP protocol layer the permitted rate(s) over Iu in the downlink direction.

The rate control procedure over Iu UP is controlled by the entity controlling the rate control over UTRAN i.e. SRNC.

The Iu downlink rate control procedure is invoked whenever the SRNC decides that the set of downlink permitted rates over Iu shall be modified. This set can be made of only one permitted rate among the rates that are permitted for rate control or several rates among the rates that can be rate controlled by the SRNC.

The rates that can be controlled by the SRNC are indicated to the Iu UP at establishment in addition to the rates that cannot be controlled by the RNC e.g. such as DTX rates for certain RABs.

The procedure can be signalled at any time when transfer of user data is not suspended by another control procedure.

The Procedure control function upon request of upper layer prepares the RFCI bitmap of downlink permitted rates.

The frame handler function calculates the frame CRC, formats the frame header into the appropriate PDU Type and sends the Iu UP frame PDU to the lower layers for ~~transfer~~transfer across the Iu interface.

Upon reception of a rate control frame, the Iu UP protocol layer checks the consistency of the Iu UP frame as follows:

- The Frame handler checks the consistency of the frame header and associated CRC. If correct, the frame handler passes procedure control part to the procedure control functions.
- The procedure control functions check that the new downlink permitted rate(s) are consistent with the RFCI set received at initialisation. They also verify that non-rate controllable rates are still permitted. If the whole rate control information is correct, the procedure control functions passes the rate control information to the NAS Data Streams specific functions.
- The NAS data streams specific functions forward to the rate control information in a Iu-UP-Status indication primitive.

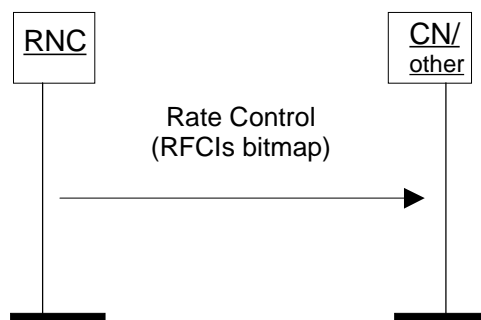

Figure 1140. Successful Rate Control

### 6.5.4.2 Unsuccessful operation

If the Iu UP in the SRNC detects that the rate control command has not been correctly interpreted or received (e.g. the downlink rate is outside the set of permitted downlink rate), the Iu UP shall retrigger a rate control procedure. If after “m” repetitions, the error situation persists, the Iu UP informs the upper layers.

If the Iu UP protocol layer receives a rate control frame that is badly formatted or corrupted, it shall ignore the rate control frame.

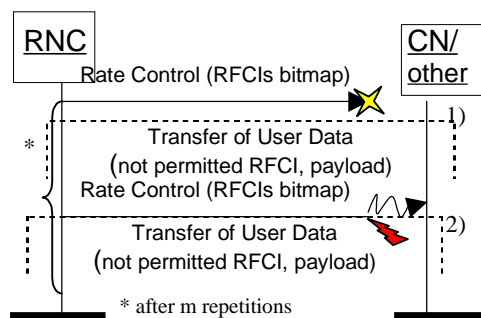

Figure 1244: Unsuccessful Transfers of rate control: 1) Frame loss 2) Corrupted Frame

### 6.5.5 Time Alignment procedure (FFS)

### 6.5.6 Handling of Abnormal Event procedure (TBD)

The details of this procedure are to be defined.

### 6.5.7 Frame Quality Classification

The Frame Quality Classification procedure uses the services of the Transfer of User Data procedure to exchange ~~across~~ the Iu UP interface the Frame Quality Classification information.

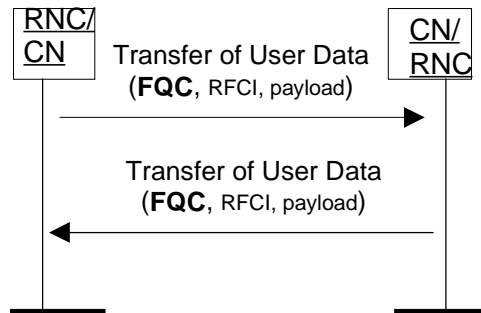

Figure 1342: Successful Transfers of User Data with FQC information

## 1.3 Elements for Iu UP communication in Support mode

### 1.3.1 Frames Formats for predefined size SDUs

#### 1.3.1.1 PDU Type 0

PDU Type 0 is defined to transfer user data over the Iu UP in support mode for pre-defined SDU sizes ~~mode~~. Error detection scheme is provided over the Iu UP for the payload part.

The following shows the Iu frame structure for PDU type 0 of the Iu UP protocol at the SAP towards the transport layers (TNL-SAP):

Bits								Number of Octets	
7	6	5	4	3	2	1	0		
PDU Type				Frame Number				1	Frame Control Part
FQC		RFCI						1	
PDU type 0 Payload CRC		PDU type 0 Header CRC						2	Frame Check Sum Part
PDU type 0 Payload CRC									
Payload Fields								0-n	Frame Payload part

Figure 1443: Iu UP PDU Type 0 Format

The Iu UP PDU Type 0 is made of three parts:

- 1) Iu UP Frame Control part (fixed size)
- 2) Iu UP Frame Check Sum part (fixed size)
- 3) Iu UP Frame Payload part (pre-defined SDU sizes)

The Iu UP Frame Control Part and the Iu UP Frame Check Sum constitute the Iu UP PDU Type 0 Frame Header.

### 1.3.1.2 PDU Type 1

PDU Type 1 is defined to transfer user data over the Iu UP in support mode for pre-defined SDU sizes ~~mode~~ when no payload error detection scheme is necessary over Iu UP (i.e. no payload CRC).

The following shows the Iu frame structure for PDU type 1 of the Iu UP protocol at the SAP towards the transport layers (TNL-SAP):

Bits								Number of Octets	
7	6	5	4	3	2	1	0		
PDU Type				Frame Number				1	Frame Control Part
FQC		RFCI						1	
Spare		PDU type 1 Header CRC						1	Frame Check Sum Part
Payload Fields								0-n	Frame Payload part

Figure 1514: Iu UP PDU Type 1 Format

The Iu UP PDU Type 1 is made of three parts:

- 1) Iu UP Frame Control part (fixed size)
- 2) Iu UP Frame Check Sum part (fixed size)
- 3) Iu UP Frame Payload part (pre-defined SDU sizes)

The Iu UP Frame Control Part and the Iu UP Frame Check Sum constitute the Iu UP PDU Type 1 Frame Header.

### 1.3.1.3 PDU Type 15

#### 1.3.1.3.1 General

PDU Type 15 is defined to perform control procedures over the Iu UP in support mode for pre-defined SDU sizes ~~mode~~. The control procedure is identified by the procedure indicator. The Frame Payload contains the data information related to the control procedure.

Figure 15 below shows the Iu frame structure for PDU Type 15 of the Iu UP protocol at the SAP towards the transport layers (TNL-SAP):

Bits								Number of Octets	
7	6	5	4	3	2	1	0		
PDU Type			Ack/Nack		PDU Type 15 Frame Number			1	Frame Control Part
Spare			Procedure Indicator					1	
PDU type 15 payload CRC		PDU type 15 header CRC						1	Frame Checksum Part
PDU type 15 payload CRC								1	
Reserved for procedure data								0-n	Frame payload part

Figure 1645: Iu UP PDU Type 15 Format for procedure sending

The Iu UP PDU Type 15 is made of three parts:

- 1) Iu UP Frame Control part (fixed size)
- 2) Iu UP Frame Check Sum part (fixed size)
- 3) Iu UP Frame Payload part (variable length, rounded up to octet)

The Iu UP Frame Control Part and the Iu UP Frame Check Sum constitute the Iu UP PDU Type 15 Frame Header.

### 1.3.1.3.2 Positive Acknowledgement

When the PDU Type 15 is used to positively acknowledge a control procedure, the PDU Type 15 takes the following structure at the TNL-SAP:

Bits								Number of Octets	
7	6	5	4	3	2	1	0		
PDU Type			Ack		PDU Type 15 Frame Number			1	Frame Control Part
Spare			Procedure Indicator					1	
Spare		PDU type 15 header CRC						1	Frame Checksum Part
Spare								1	

Figure 1746: Iu UP PDU Type 15 Format for positive ~~acknowledgment~~acknowledgement

The Iu UP PDU Type 15 for positive acknowledgment is made of two parts:

- 1) Iu UP Frame Control part (fixed size)
- 2) Iu UP Frame Check Sum part (fixed size)

The Iu UP Frame Control Part and the Iu UP Frame Check Sum constitute the Iu UP PDU Type 15 Frame Header for positive ~~acknowledgment~~acknowledgement.



### 1.3.1.3.3 Negative Acknowledgement

When the PDU Type 15 is used to negatively acknowledge a control procedure, the PDU Type 15 takes the following structure at the TNL-SAP:

Bits								Number of Octets	
7	6	5	4	3	2	1	0		
PDU Type				Nack		PDU Type 15 Frame Number		1	Frame Control Part
Spare				Procedure Indicator				1	
Spare		PDU type 15 header CRC						1	Frame Checksum Part
Spare								1	
Cause Indicator								1	Frame payload part

Figure 1847: Iu UP PDU Type 15 Format for negative ~~acknowledgment~~acknowledgement

The Iu UP PDU Type 15 for negative acknowledgment is made of three parts:

1. Iu UP Frame Control part (fixed size)
2. Iu UP Frame Check Sum ~~part~~ (fixed size)
3. Iu UP Frame Payload part (fixed size)

The Iu UP Frame Control Part and the Iu UP Frame Check Sum constitute the Iu UP PDU Type 15 Frame Header for negative ~~acknowledgment~~acknowledgement.

### 1.3.1.3.4 Procedures Coding

#### 1.3.1.3.4.1 ~~Initialization~~Initialisation

The Figure below specifies how the ~~initialization~~initialisation procedure is coded.

Bits								Number of Octets	
7	6	5	4	3	2	1	0		
PDU Type (=15)				Ack/Nack		PDU Type 15 Frame Number		1	Frame Control Part
Spare				Procedure Indicator (=0)				1	
PDU type 15 payload CRC		PDU type15 header CRC						2	Frame Checksum part
PDU type15 payload CRC									
Spare				Number of subflows (N)		Chain <del>ind</del> Ind		1	Frame payload part
Spare	LI	1 <sup>st</sup> RFCI						1	
<del>Data of LI</del> Length of subflow 1 <del>for RFCI</del>								1 or 2 (dep. LI)	
<del>Data of LI</del> Length of subflow 2 to N <del>for RFCI</del>								(N-1)x(1 or 2)	
Spare	LI	2 <sup>nd</sup> RFCI						1	
<del>Data of LI</del> Length of subflow 1 <del>for RFCI</del>								1 or 2 (dep. LI)	
<del>Data of LI</del> Length of subflow 2 to N <del>for RFCI</del>								(N-1)x(1 or 2)	
...									

Figure 1918: lu UP PDU Type 15 used for ~~Initialization~~Initialisation

1.3.1.3.4.2 Rate Control

The Figure below specifies how the rate control procedure is coded.

Bits							Number of Octets	
7	6	5	4	3	2	1		
PDU Type			Ack/Nack		PDU Type 15 Frame Number		1	Frame Control Part
Spare			Procedure Indicator				1	
PDU type 15 payload CRC		PDU type 15 header CRC					1	Frame Checksum Part
PDU type 15 payload CRC						1		
Spare		Number of RFCIs Indicator (N)					0-n	Frame payload part
Padding when needed (0)		RFCI N-1 Ind	...	RFCI 2 Ind	RFCI 1 Ind	RFCI 0 Ind		

Figure 2049: Iu UP PDU Type 15 Format used for Rate Control

#### 1.3.1.3.4.3 Time Alignment (FFS)

#### 1.3.1.3.4.4 Abnormal Event (TBD)

This is to be defined

### 1.3.2 Frames content definition and Frames coding

#### Frame Number

The Iu UP frame numbering is handled by a Frame Number. The purpose of the Frame Number is to provide the receiving entity with a mechanism to keep track of lost Iu UP frames. For a given user data connection, there is no relations between the frame numbers of frames sent in the downlink direction and the frame numbers of frames sent in the uplink direction.

The frame number is in bit 0 to bit 3 in the first octet of the frame the value varying from 0 to 15.

#### PDU Type 15 Frame Number

The Iu UP frame numbering is handled by a Frame Number. The purpose of the PDU Type 15 Frame Number is to provide the receiving entity with a mechanism to keep track of lost Iu UP frames.

It is also used to relate the ~~acknowledgment~~ **acknowledgement** frame to the frame being acknowledged i.e. the same PDU Type 15 Frame Number is used in the acknowledgement frame as the one used in the frame being acknowledged.

The value range of the PDU Type 15 Frame number is 0-3.

#### PDU Type

The PDU type indicates the structure of the Iu UP frame. The field takes the value of the PDU Type it identifies: i.e. 0 for PDU Type 0. The PDU type is in bit 4 to bit 7 in the first octet of the frame.

#### RAB sub-Flow Combination Indicator (RFCI)

The RFCI is stored in bit 0 to bit 5 of the second octet of the frame control part. The RFCI can get values ranging from 0 to 62. The value 63 is reserved for indicating that RFCI is not applicable for the current PDU.

## Ack/Nack

The Ack/Nack field tells if the frame is a control procedure frame or an acknowledgement for a control procedure frame.

Value	Definition
0	Procedure sending
1	Ack
2	Nack
3	Spare

## Procedure Indicator

The Procedure Indicator identifies the control procedure in the current frame. The meaning of the Procedure Indicator is given in the table below.

Value	Definition
0	<del>Initialization</del> Initialisation procedure
1	Rate control
2	FFS (Time Alignment)
3	TBD (Abnormal Event)
4-15	Spare

## PDU type 0 Header CRC

This field contains the CRC of all fields in Frame Control Part. The CRC is a 6-bit checksum based on the generator polynomial  $G(D) = D^6 + D^5 + D^3 + D^2 + D^1 + 1$ .

With this CRC all error bursts shorter than 7 bits are detected, as well as all odd number of bits faulty (and two-bit faults) when the protected area is shorter than 24 bits, (max 3 octets).

## PDU type 0 Payload CRC

This field contains the CRC of the Frame Payload. The CRC is a 10-bit checksum based on the generator polynomial  $G(D) = D^{10} + D^9 + D^5 + D^4 + D^1 + 1$ .

With this CRC all error bursts shorter than 11 bits are detected, as well as all odd number of bits faulty (and two-bit faults) when the protected area is shorter than 500 bits (max 62 octets).

## PDU type 1 Header CRC

Same as PDU Type 0 Header CRC.

## PDU type 15 Header CRC

This field contains the CRC of all fields in Frame Control Part. The CRC is a 6-bit checksum based on the generator polynomial  $G(D) = D^6 + D^5 + D^3 + D^2 + D^1 + 1$ .

With this CRC all error bursts shorter than 7 bits are detected, as well as all odd number of bits faulty (and two-bit faults) when the protected area is shorter than 24 bits, (max 3 octets).

## PDU type 15 Payload ~~Check-Sum~~CRC

This field contains the CRC of the Frame Payload part. The CRC is a 10-bit checksum based on the generator polynomial  $G(D) = D^{10} + D^9 + D^5 + D^4 + D^1 + 1$ .

With this CRC all error bursts shorter than 11 bits are detected, as well as all odd number of bits faulty (and two-bit faults) when the protected area is shorter than 500 bits (max 62 octets).

## Chain Indicator

Chain indicator is used to indicate whether the control procedure frame is the last frame related to the control procedure.

The Chain Indicator is set to 0 when this is the last frame.

The Chain Indicator is set to 1 when this is not the last frame.

## Number of Subflows

Number of Subflows field indicates the number of subflows the RAB is made of. It is used to decode the SDU size information data lengths.

The Number of Subflows can range from 1 to 7.

## Length Indicator (LI)

LI: Length Indicator, indicates if 1 (LI=0) or 2 (LI=1) octets is used for the RAB subflow size information.

LI is 1 when more than 255 bits is used for a subflow.

## Number of RFCIs Indicator

Number of RFCI Indicator indicates the number of RFCI Indicators present in the control procedure frame.

Number of RFCI Indicator can range from 0 to 63.

## RFCI Indicator

RFCI Indicator points to an RFCI number e.g. RFCI Indicator 0 points to RFCI 0, RFCI Indicator 1 points to RFCI 1, etc...

RFCI Indicator set to 0 indicates that the corresponding RFCI number is punctured out of the RFCI set.

RFCI Indicator set to 1 indicates that the corresponding RFCI number remains in the RFCI set.

## Frame Quality Classification (FQC)

Frame Quality Classification is used to classify the Iu UP frames depending on whether errors have occurred in the frame or not. Frame Quality Classification is dependent on the RAB attribute 'Delivery of erroneous SDUs'.

The meaning of the FQC field is specified below:

FQC Value	Definition
0	Frame good
1	Frame bad
2	Spare
3	Spare

## Cause Indicator

Cause field is used to indicate the reason for the control procedure execution.

The meaning of the Cause Indicator is given in the table below.

Value	Definition
0	Reserved
1	Frame Format Error
2-15	Spare
16	Unknown field
17-31	Spare
32-255	Spare

### 1.3.3 Timers

$T_{INT}$

This Timer is used to supervise the reception of the initialisation acknowledgement frame from the peer Iu UP instance. This Timer is set by O&M.

## 1.4 Handling of unknown, unforeseen and erroneous protocol data

TBD

---

## Communication Primitives for the Iu UP protocol layer

### Modelling Principle

The principle illustrated by the figure below is used for modelling the primitives towards the protocol layer:

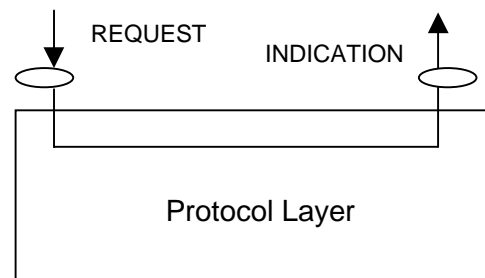

[Figure 21: Modelling principle](#)

## Primitives towards the upper layers at the RNL SAP

### General

The Iu UP protocol layer interacts with upper layers as illustrated in the figure above. The interactions with the upper layers are shown in terms of primitives where the primitives represent the logical exchange of information and control between the upper layer and the Iu UP protocol layer. They do not specify or constraint implementations.

The following primitives are defined:

- Iu-UP-DATA
- Iu-UP-STATUS

- Iu-UP-UNIT-DATA

**Table 1. Iu UP protocol layer service primitives towards the upper layer at the RNL SAP**

Primitive	Type	Parameters	Comments
Iu-UP-DATA	Request	Iu-UP-payload	
		Iu-UP-control	RFCI
	Indication	Iu-UP-payload	
		Iu-UP-control	RFCI FQC
Iu-UP-Status	Indication	Iu-UP-Procedure-Control	Abnormal Event (TBD)
			Initialisation
			RFCI bitmap
		<i>Time Alignment (FFS Note 1)</i>	
Request	Iu-UP-Procedure-Control	Abnormal Event	
		RFCI bitmap	
Iu-UP-UNIT-DATA	Request	Iu-UP-payload	
	Indication	Iu-UP-payload	

Primitive usage is function of the mode of operation of the Iu UP protocol. The following table provides the association between Iu UP primitives towards the upper layers and the Iu UP mode of operation:

**Table 2. Iu UP protocol layer service primitives related to the Iu UP mode of operation and function within the mode of operation:**

Primitive	Type	Mode of Operation
Iu-UP-DATA	Request	SMpSDU
	Indication	SMpSDU
Iu-UP-Status	Request	SMpSDU
	Indication	SMpSDU
Iu-UP-UNIT-DATA	Request	TrM
	Indication	TrM

## Iu-UP-DATA-REQUEST

This primitive is used as a request from the upper layer Iu NAS Data Stream entity to send a RAB SDU on the established transport connection. This primitive also includes the RFCI of the payload information included in the primitive.

The Iu UP Frame protocol layer forms the Iu UP data frame, the Iu Data Stream DU being the payload of the Iu UP frame, and transfers the frame by means of the lower layer services.

## Iu-UP-DATA-INDICATION

This primitive is used as an indication to the upper layer entity to pass the Iu NAS Data Stream User Plane information of a received Iu UP frame.

This primitive also includes the RFCI of the payload information included in the primitive.

At the RNL-SAP, this primitive may include an Frame Quality Classification indication.

This primitive may also include information aiming at informing the upper layers of a faulty situation that relates to the payload included in the primitive.

Note 1: Time Alignment is FFS.

## Iu-UP-STATUS-REQUEST

~~This primitive is used to pass down to the Iu UP, the rate control information necessary for changing the permitted downlink rate(s) over Iu. The rate control information consists of the RFCI bitmap.~~

This primitive is used to report that a fault has been detected.

## Iu-UP-STATUS-INDICATION

This primitive is used to report to the upper layer entity that a fault has been detected. The information concerning that fault is characterised by the Abnormal event information passed to the upper layer.

This primitive is also used in the context of the initialisation control procedure to pass to the upper Iu DS layer e.g. the RFC set and the associated RFCIs to be used in the communication phase.

This primitive is used to indicate to the upper layers the set of permitted rate(s) in the downlink direction over Iu. The set of permitted rate(s) is represented by the RFCI bitmap.

This primitive is also used to indicate when a frame has been dropped as a result of frame quality classification handling.

Note 1: Time Alignment is FFS.

## Iu-UP-UNIT-DATA-REQUEST

This primitive is used as a request from the upper layer to send an Iu UP payload on the established transport connection.

The Iu UP protocol layer transfers the Iu Data Stream DU by means of the lower layer services without adding any protocol header overhead.

## Iu-UP-UNIT-DATA-INDICATION

This primitive is used as an indication to the upper layer entity to pass the Iu UP payload.



## Primitives towards the transport layers at TNL SAP

### General

Access to the Transport network Layer is ~~performed~~performed through a generic SAP: TNL-SAP.

When the Transport Network upper layer consists of AAL2, the TNL SAP maps onto the AAL-SAP through which communication is performed using specific AAL primitives.

When the Transport Network upper layer consists of GTP-U, the TNL SAP maps onto the GTP-U SAP through which communication is performed using generic primitives.

The choice of communication, specific or generic, through the TNL SAP is fixed by the Radio Network Layer control plane logic. This choice is based on the requirements placed by e.g. the RAB characteristics, the CN domain requesting the RAB establishment or other operator's choice.

### ~~Primitives at the TNL-SAP with~~ ATM/AAL2 based Transport layer

#### General

When the Iu UP protocol layer uses the services of an ATM/AAL2 transport, it uses an established AAL2 connection for transferring frames between the peer TNL-SAPs at both end of the Iu User plane access points. The Transport Network Control Plane over Iu handles the signalling to establish and release the AAL2 call connections.

#### ~~7.3.3~~ AAL2 Service Primitives used by the Iu UP protocol

AAL2 services and primitives used at the Service Access Point from the AAL2 layer are shown in the following table:

**Table 3. AAL2 primitives and parameters**

Primitive	Type	Parameters	Comments
SSSAR-UNITDATA	Request	SSSAR-INFO	
		SSSAR-UUI	Not used (Note 1)
SSSAR-UNITDATA	Indication	SSSAR-INFO	
		SSSAR-UUI	Not used (Note 1)

**Note 1: The setting of this field is set to not used i.e. decimal value 26 according to [8].**

The primitives of Table 3 are the standard primitives of [5]. These primitives are intended to be used in the Iu UP.

### ~~7.3.4~~ Primitives at the TNL-SAP with GTP-U based Transport Layer

#### General

When the Iu UP protocol layer uses the services of a GTP-U transport, it uses an established GTP-U tunnel for transferring frames between the- GTP-U tunnel endpoints at both end of the Iu User plane access points. The RANAP Control Plane signalling over Iu handles the signalling to establish and release the GTP-U tunnels.

#### ~~7.3.5~~ Generic Service Primitives used by the Iu UP protocol

Generic primitives are used at the GTP-U SAP. They are shown in the following table:

**Table 4. Generic primitives and parameters to and from GTP-U layer**

<b>Primitive</b>	<b>Type</b>	<b>Parameters</b>	<b>Comments</b>
Iu-UP-UNITDATA	Request	Iu-UP-payload	
Iu-UP-UNITDATA	Indication	Iu-UP-payload	

# Annex A (Informative): Illustration of usage of RFCI for AMR speech RAB.

This annex contains ~~information~~information related to usage of RFCIs in the context of AMR speech RAB.

The following figure illustrates the RFCI allocation and flow throughout the UTRAN.

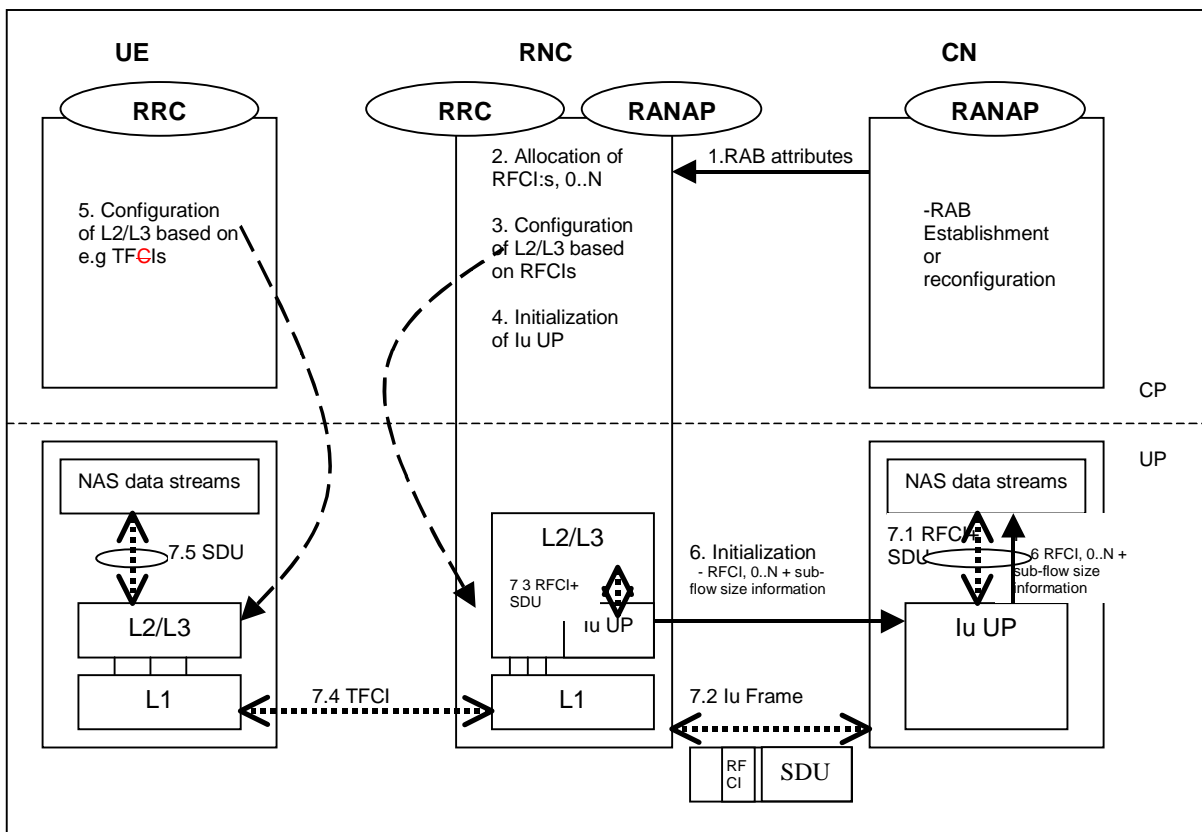

1. **RAB Attributes:** at RAB establishment or reconfiguration, the SDU size information parameter is passed to UTRAN. The SDU information is organised per BER i.e. RAB sub Flow. For instance, 12.2 kbits/s AMR codec is passed as RAB sub flow 1 SDU size: 81 bits –class A bits-, RAB sub flow 2 SDU size: 103 –class B bits-, as RAB sub flow 3 SDU size: 60 –class C-, which makes one RAB sub Flow Combination. This is done for all rates (i.e. all codec modes, DTX also if included). The lu UP is used in support mode for predefined SDU size.
2. **Allocation of RFCIs:** the RNC dynamically allocates an identification (RFCI) to each permitted/possible combinations it can offer. E.g. for 12.2 kbits/s, the RNC allocates RFCI 3 (according to the example table 2)
3. **Configuration of L2/3 based on RFCIs:** RFCIs are used to configure the L23. RLC is used transparently. MAC configures its co ordinated DCHs with the RFCIs and associate one RFCI to one TFCI
4. **Initialization/Initialisation of lu UP:** the RNC reports the permitted combinations it can offer to the transcoder using an inband lu initialisation frame containing the RFCIs and associated RAB sub Flow sizes.
5. **Configuration of L2/3 based on e.g. TFCIs:** idem as 3. L23 ~~will~~may use e.g. TFCI to communicate with the Codec about the RAB sub-Flow structure of the SDU received or to be sent.
6. **RFCIs+ SDU size information:** the RFCIs and associated RAB sub Flow sizes are received within the lu initialisation frame are passed to the Codec for configuration.
7. **Example of DL frame transfer:**
  - 7.1. The Codec encodes a 12.2 kbits/s frame. It sends down to the lu UP and SDU with an ~~asseiated~~associated RFCI equals to 3 (in this example)

- 7.2. The Iu UP packs a frame with a header containing an RFCI set to value 3, and the payload made of the SDU received from the Codec.
- 7.3. The Iu UP passes to L23, the Iu frame payload (the Codec SDU) and the RFCI. The L23 uses this RFCI to break the Iu frame onto the *coordinated-co-ordinated* DCHs corresponding to the different bits protection classes. The corresponding TFCI is selected.
- 7.4. The radio frame is sent with the TFCI chosen by MAC
- 7.5. The L23 receives the SDUs on the *coordinated-co-ordinated* DCHs, combined them back and uses e.g. the TFCI to indicate to the codec the structure of the received frame.

The following table shows RAB sub-flow SDU sizes for a RAB with variable source rate as they are signalled in RAB assignment request in RANAP.

Table 1: Example of SDU sizes for AMR with DTX

RAB sub-flows			Total size of bits/RAB sub-flows combination	Source rate
RAB sub-Flow 1	RAB sub-Flow 2	RAB sub-Flow 3		
39	56	0	95	Source rate 1
49	54	0	103	Source rate 2
55	63	0	118	Source rate 3
55	79	0	134	Source rate 4
61	87	0	148	Source rate 5
75	84	0	159	Source rate 6
65	99	40	204	Source rate 7
81	103	60	244	Source rate 8
39	0	0	39	Source rate 9
⋮	⋮	⋮	⋮	⋮
0	0	0	0	Source rate M

NOTE 1: In the table above the *grayedgreyed* area shows what is signalled in RANAP RAB establishment request.

NOTE 2: In the table above the number of sub-flows is informative only.

SRNC allocates one or more possible/available RAB sub-flow combination(s) and generates RAB sub-flow combination set. RAB sub-flow combination number is dynamically generated by SRNC. This RAB sub-flow combination set is signalled towards CN with user plane signalling as described in [1]. The signalling towards UE is to be defined by TSG-RAN WG2.

#### RAB sub-flow combination set

A RAB sub-flow combination indicator, RFCI, indicates which RAB sub flow combination will be used for the Iu user frames. In the communication phase the RFCI is included in the user frame, and the RFCI state the structure of the user frame.

Table 2 below exemplifies the allocation of 4 different RAB sub-flows combinations for 3 sub-flows and generating of RAB sub-flows combination set.

Table 2: Example of Allocation of RAB sub-flows combination indicator

	RFCI (RAB sub-Flow Combination Indicator)	RAB sub- Flow 1	RAB sub- flow 2	RAB sub- flow 3	Total	Source rate
<b>RAB sub- flows combin ation set</b>	0	0	0	0	0	Source rate 1
	1	39	0	0	39	Source rate 2
	2	39	56	0	95	Source rate 3
	3	81	103	60	244	Source rate 4

NOTE: In the table above the ~~grayed~~ ~~grayed~~ area shows the part that is sent in the ~~initialization~~ ~~initialisation~~ procedure in Lu UP. This is what constitutes the RAB subflow combination set.

# Annex B (Informative): Illustration of protocol states in the Iu UP.

This annex contains ~~information~~information related to possible protocol states for operation of the Iu UP. This annex does not constraint implementation and is for illustration purposes only.

The state model is common for both ends of the Iu UP so that the protocol machines are operating ~~symmetrically~~symmetrically. This approach is taken to facilitate state description for all cases including TFO and TrFO .

Note: Primitive Iu-UP-CONFIG-Req is used by upper layers to configure the Iu UP protocol layer. It is used in this annex for illustrative purposes and therefore it is not defined in chapter 7.

## B.1 Protocol state model for transparent mode

The following figure illustrates the state model for transparent mode Iu UP instances. A transparent mode instance can be in one of following states.

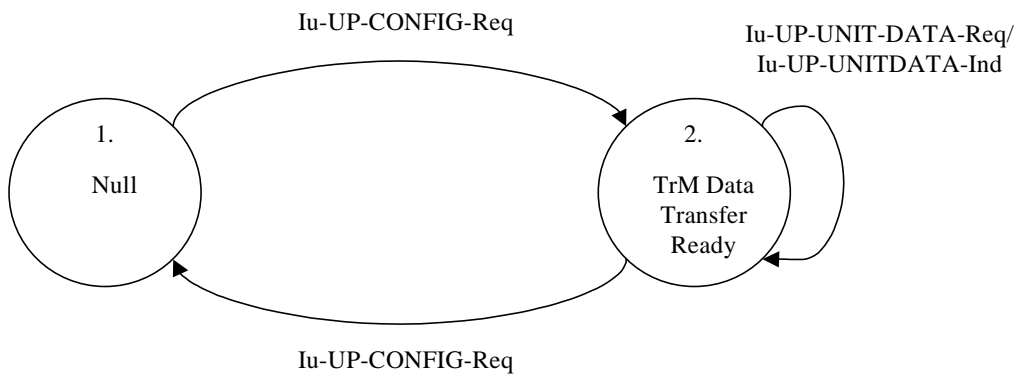

Figure: Protocol state model for transparent mode.

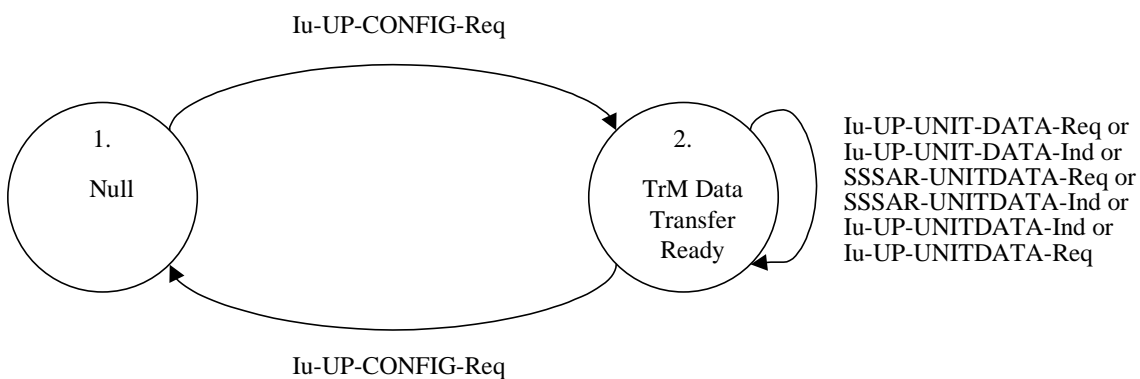

Figure: Protocol state model for transparent mode.

### B.1.1 Null State

In the null state the Iu UP instance does not exist and therefore it is not possible to transfer any data through it.

Upon reception of a Iu-UP-CONFIG-Req from higher layer the Iu UP instance is created and transparent mode data transfer ready state is entered. The mode information is received either through RANAP signalling or directly in the CN node. In the Iu-UP-CONFIG-Req e.g. the following information will be indicated:

- Transparent mode

### B.1.2 Transparent Mode Data Transfer Ready State

In the transparent mode data transfer ready state, transparent mode data can be exchanged between the entities.

Upon reception of Iu-UP-CONFIG-Req indicating release from higher layer, the Iu UP instance is terminated and the null state is entered.

## B.2 Protocol state model for support mode for predefined SDU sizes

The following figure illustrates the state model for support mode Iu UP instances. A support mode instance can be in one of the following states.

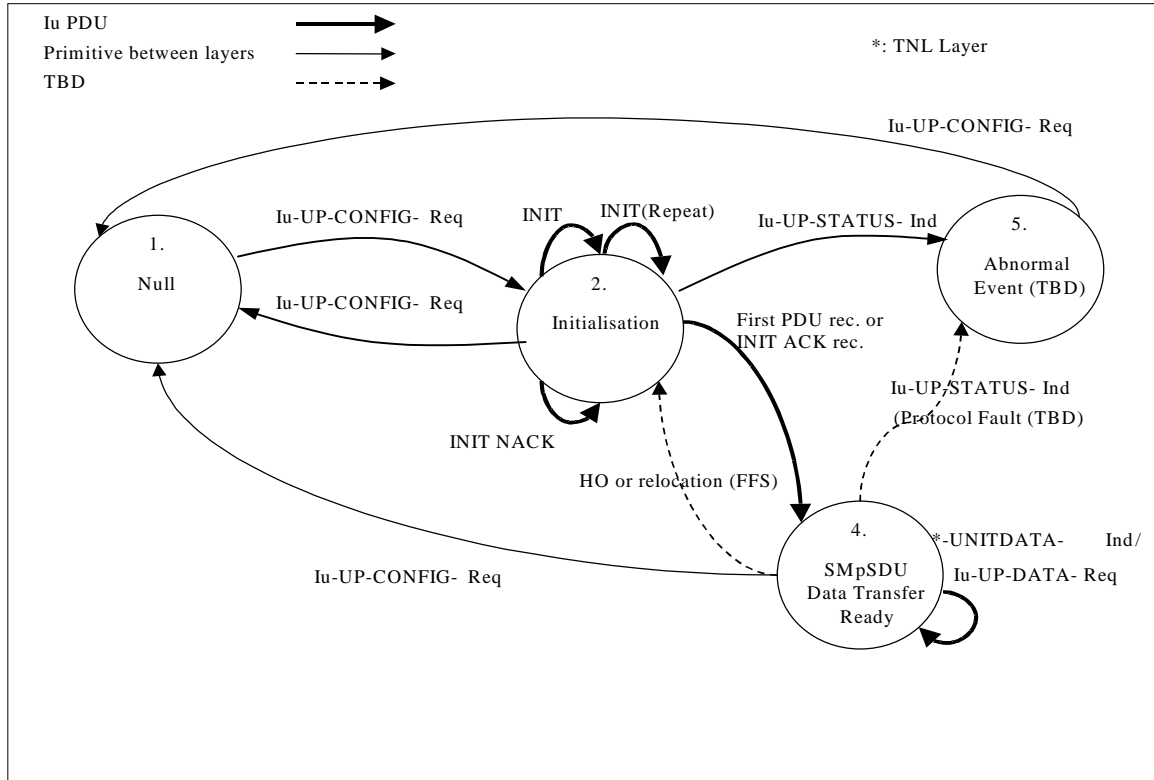

Figure: Protocol state model for support mode



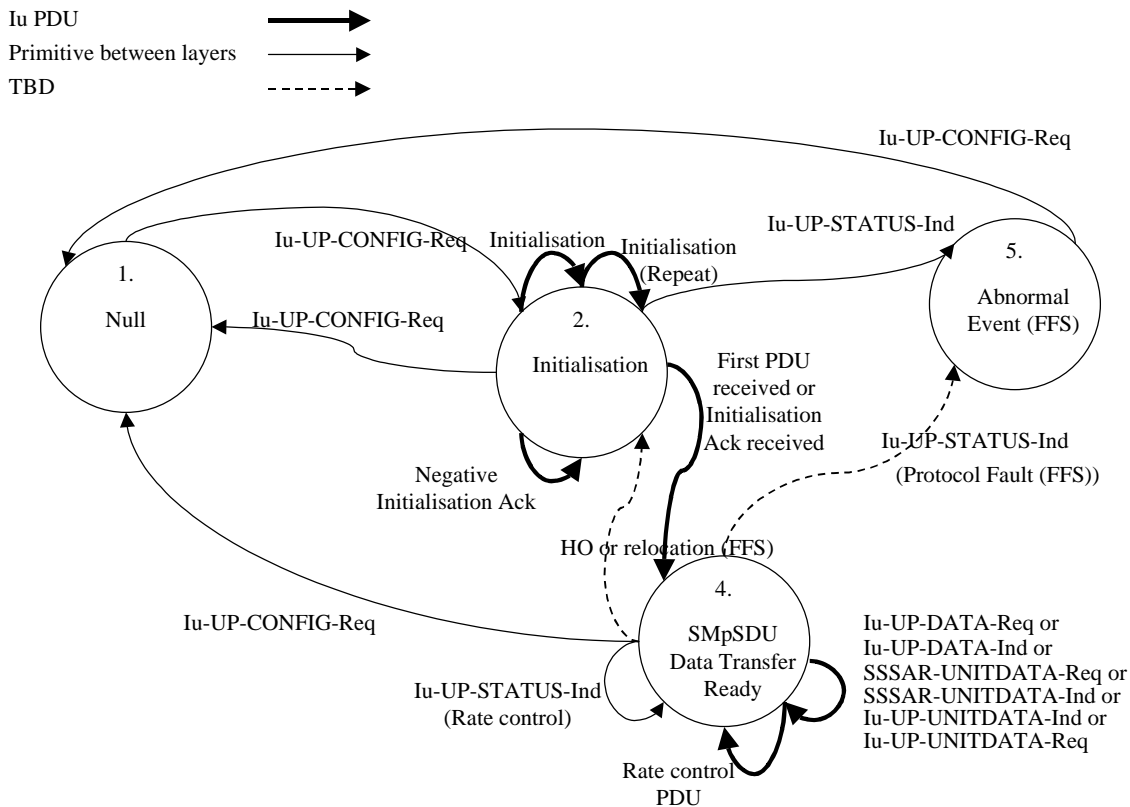

Figure: Protocol state model for support mode.

### B.2.1 Null State

In the null state the Iu UP instance does not exist and therefore it is not possible to transfer any data through it.

Upon reception of a *Iu-UP-CONFIG-Req* from higher layer the Iu UP instance is created and initialisation state is entered. In the *Iu-UP-CONFIG-Req* e.g. the following information could be indicated:

- Support mode for predefined SDU sizes
- Time alignment (FFS)
- Indication of delivery of erroneous SDUs
- Periodicity

### B.2.2 Initialisation State

In the initialisation state the instance exchanges initialisation information with its peer Iu UP instance.

Upon reception of *Iu-UP-CONFIG-Req* indicating release from higher layer, the Iu UP instance is terminated and the null state is entered.

Upon sending or receiving of an initialisation frame (~~INIT~~) the Iu UP instance remains in the Initialisation state. The sending side starts a supervision timer  $T_{INIT}$ . The receiving side acknowledges the ~~INIT~~ initialisation frame with a positive acknowledgement (~~INIT ACK~~) or a negative acknowledgement (~~INIT NACK~~). The Iu UP remains in initialisation state.

Upon reception of an initialisation acknowledgement frame (~~INIT ACK~~), the supervision timer  $T_{INIT}$  is stopped and the Iu UP instance enters SMpSDU data transfer ready state.

Upon reception of a first PDU after sending a positive acknowledgement (~~INIT ACK~~), the Iu UP instance enters SMpSDU data transfer ready state.

Upon reception of an initialisation negative acknowledgement frame (~~INIT-NACK~~) or at the expiry of timer  $T_{\text{INIT}}$ , the initialisation frame is repeated and the timer  $T_{\text{INIT}}$  is restarted. The initialisation frame can be repeated  ~~$\sqrt{T(\text{Init})_n}$~~ -times.

If after  ~~$\sqrt{T(\text{Init})_n}$~~  repetitions, the initialisation procedure is unsuccessfully terminated (due to  ~~$\sqrt{T(\text{Init})_n}$~~ -negative acknowledgements or timer expiries), Iu-UP-Status-Indication primitive is sent to the higher layers and abnormal event state is entered.

### B.2.3 Support Mode Data Transfer Ready State

In the support mode data transfer ready state, support mode data can be exchanged between the peer Iu UP instances.

Upon reception of Iu-UP-DATA-Request ~~from the upper layer -or SSSAR-UNITDATA-Indication~~ or ~~Iu-UP-UNITDATA-Indication~~ from TNL layer, appropriate user data transfer procedures are performed. Iu UP instance remains in the SMpSDU data transfer ready state.

~~Upon sending of Iu-UP-DATA- Indication or SSSAR-UNITDATA-Request or Iu-UP-UNITDATA-Request the Iu UP instance remains in the SMpSDU data transfer ready state.~~

~~Upon sending or receiving of a rate control PDU the Iu UP instance remains in the SMpSDU data transfer ready state.~~

~~Upon sending of a Iu-UP-STATUS-Indication (rate control) the Iu UP instance remains in the SMpSDU data transfer ready state.~~

Upon reception of Iu-UP-CONFIG-Req from higher layer the Iu UP instance is terminated and the null state is entered.

Upon detection of a protocol fault, Iu-UP-STATUS-Indication is sent to upper layer and abnormal event state is entered.

TBD event (FFS): In case of handover or relocation, initialisation procedures may have to be performed and Iu UP instance may have to enter the initialisation state.

### B.2.4 Abnormal Event State (TBD)

Abnormal event state is (TBD). However, an assumption can be made that upon reception of Iu-UP-CONFIG-Req from higher layer the Iu UP instance is terminated and the null state is entered.

~~This timer is used to supervise the reception of the time alignment acknowledgement frame from the peer Iu UP instance.~~

---

## Annex C (Informative): Open Issues of the Iu UP.

This annex contains information related to open issues left in the Iu UP protocol.

1. Handling of Abnormal Event and Error Handling
2. Timing over Iu, including Time Alignment

## History

Document history		
Edition x		Publication
0.0.1	Feb 1999	First draft
0.0.2	March 1999	Revised following RAN WG3#2 meeting: <ul style="list-style-type: none"> <li>- TSG SA S2-99080: Iu UP instances</li> <li>- TSG RAN WG3#2 R3-99195</li> </ul>
0.1.0	April 1999	Prepared for the RAN WG#3 meeting. <ul style="list-style-type: none"> <li>- Document noted TSG SA S2-99080: Iu UP instances</li> </ul>
0.1.1	May 1999	Revised following RAN WG3#3 meeting <ul style="list-style-type: none"> <li>- Editorial additions: abbreviations, corrected references</li> <li>- TSG R3 (99) 281: incorporation of the proposals, inclusion of the frame format, RAB Format Selection and Time Alignment FFS</li> <li>- TSG R3 (99) 368: alignment of the 281 proposals with the co ordinated data streams concepts of 368.</li> <li>- Inclusion of detailed comments of the Iu SWG on TSG R3 (99) 281</li> <li>- Note: <ul style="list-style-type: none"> <li>- <i>TSG R3 (99) 257: provisions for load sharing on Iu between RNC and CN PS, moved to 25.414</i></li> <li>- <i>TSG R3 (99) 276: incorporation of the two parts of proposal 1 (i.e. resulting in creation of appendix A): moved to 25.414</i></li> </ul> </li> </ul>
0.1.2	May 1999	Revised by editor according to WG3#3 closing plenary meeting recommendations <ul style="list-style-type: none"> <li>-Include Appendix A</li> <li>-Include Section 3.4.: Specification status</li> </ul>
0.1.3	June 1999	Revised following RAN WG3#4 meeting. <ul style="list-style-type: none"> <li>- Removal of the temporary appendix containing the GTP-U agreed proposal <i>TSG R3 (99) 276. Proposed in Liaison TSGR3#4 (99) 569</i></li> <li>- Move the <del>specifications</del>specification status <del>abletable</del> to Annex B. Align layout with 25.401 editors proposal</li> <li>- Include TSGR3-99458, TSG R3-99459</li> <li>- Add reference to AAL2 ITU specifications</li> </ul>
0.1.4	June 1999	- Transparent/ Support mode
0.2.0	July 1999	- Approved version with comments proposed in R3-99593

0.2.1	July 1999	<ul style="list-style-type: none"> <li>- Introduction of Mode concept: R3-99717</li> <li>- R3-99718: Changes to 25.415 due to mode concept</li> <li>- R3-99719: Modelling of primitives for the Iu UP layer</li> <li>- R3-99724: Principles related to RAB sub flows</li> <li>- R3-99786, Summary of Iu SWG</li> </ul>
0.2.2	August 1999	<ul style="list-style-type: none"> <li>- Editor's proposal: R3-99339.</li> </ul>
1.0.0.	August 1999	<ul style="list-style-type: none"> <li>- Agreed editor's proposal: v0.2.2</li> </ul>
1.0.1	August 1999	<ul style="list-style-type: none"> <li>- Introduction of changes agreed from: R3-99979: Time alignment procedure without user data transmission R3-99936: Frame coding for PDU type 0 for Support Mode for predefined SDU size R3-99935: Downlink Rate Control over Iu</li> </ul>
1.0.2	September 1999	<ul style="list-style-type: none"> <li>- Editor's proposal: Text font <del>harmonized</del>harmonised at "Times New Roman 10" and few typos, heading level etc.. Clarification of Initialisation procedure Generic Transport Network Layer SAP created. GTP-U SAP is kept (according to latest N2 decision) but uses generic primitives Transfer of User Data procedure described Primitive: Status passes procedure control information Primitive Data passes user data information and frame control information (RFCI, Frame Classification) Removal of RFCI on Uu SAR ca be used: determined based on maximum of SDU at Iu UP establishment UUI is set to decimal value 26 when not used by the AAL2 user. Removal of empty Annex A, replaced by Informative Annex B</li> </ul>
1.0.3	September 1999	<ul style="list-style-type: none"> <li>- Updates from RAN3#7</li> </ul>
1.0.4	September 1999	<ul style="list-style-type: none"> <li>- Updates of Iu SWG RAN3#7 review</li> </ul>
1.0.5	September 1999	<ul style="list-style-type: none"> <li>- Version recommended by Iu SWG for presentation to RAN3#7 plenary</li> </ul>
2.0.0	September 1999	<ul style="list-style-type: none"> <li>- Approved at RAN3#7. Recommended for approval by TSG RAN as version 3.0.0</li> </ul>

Rapporteur for 3GPP RAN 25.415 is:

Alain G. Maupin  
Ericsson Radio Systems

Tel. : +46 8 404 4379

Fax : +46 8 404 3597

Email : [alain.maupin@era.ericsson.se](mailto:alain.maupin@era.ericsson.se)

This document is written in Microsoft Word version 7. 0/97.

## CHANGE REQUEST

**25.415 CR 003**

Current Version: **3.0.0**

GSM (AA.BB) or 3G (AA.BBB) specification number ↑

↑ CR number as allocated by MCC support team

For submission to: **TSG-RAN #6**  
*list expected approval meeting # here ↑*

for approval   
for information

strategic   
non-strategic  *(for SMG use only)*

Form: CR cover sheet, version 2 for 3GPP and SMG The latest version of this form is available from: <ftp://ftp.3gpp.org/Information/CR-Form-v2.doc>

**Proposed change affects:** (U)SIM  ME  UTRAN / Radio  Core Network   
*(at least one should be marked with an X)*

**Source:** TSG-RAN WG3 **Date:** 28<sup>th</sup> Oct 1999

**Subject:** Addition of definitions for transcoder operation

**Work item:**

**Category:** F Correction  **Release:** Phase 2   
*(only one category shall be marked with an X)* A Corresponds to a correction in an earlier release  Release 96   
B Addition of feature  Release 97   
C Functional modification of feature  Release 98   
D Editorial modification  Release 99   
Release 00

**Reason for change:** This CR proposes additional definitions and concepts related to TFO and TrFO.

**Clauses affected:** 3.3

**Other specs affected:** Other 3G core specifications  → List of CRs:  
Other GSM core specifications  → List of CRs:  
MS test specifications  → List of CRs:  
BSS test specifications  → List of CRs:  
O&M specifications  → List of CRs:

**Other comments:** Was R3-99G06 at RAN3 #8 lu SWG

## Concepts

### **Iu UP mode of operation:**

One objective of the Iu User Plane (UP) protocol is to remain independent of the CN domain (Circuit Switched or Packet Switched) and to have limited or no dependency with the Transport Network Layer. Meeting this objective provides the flexibility to evolve services regardless of the CN domain and to migrate services across CN domains.

The Iu UP protocol is therefore defined with modes of operation that can be activated on a RAB basis rather than on a CN domain basis or (tele)service basis. The Iu UP mode of operation determines if and which set of features shall be provided to meet e.g. the RAB QoS requirements.

### **Iu UP protocol PDU Type:**

⚡

The Iu UP protocol PDU Types are defined for a given Iu UP mode of operation. An Iu UP PDU Type represents a defined structure of an Iu UP protocol frame. For instance, a frame made of a certain Frame Header mask part and a Frame Payload part would be specified as a certain PDU type valid for a given Iu UP mode of operation.

### **Tandem Free Operation (TFO):**

Configuration of a Speech or Multimedia call for which Transcoders are physically present in the communication path but transcoding functions are disabled or partially disabled. The Transcoders may perform control and/or protocol conversion functions.

### **Transcoder (TC):**

Physical device present in the network responsible for the transcoding of the speech data between two speech codecs or coding schemes (The Transcoder may also include other functions, i.e. Rate Adaptation in GSM).

### **Transcoder Free Operation (TrFO):**

Configuration of a Speech or Multimedia call for which Transcoders are not present in the communication path.