

TS 25.142 V2.2.0 (1999-12)

**3rd Generation Partnership Project;
Technical Specification Group Radio Access Network;
Working Group 4;
Base station conformance testing (TDD)**



Reference

DTS/TSG<name abbrev>-0<WG no><spec no> U

Keywords

<keyword[, keyword]>

3GPP

Postal address

3GPP support office address

650 Route des Lucioles - Sophia Antipolis
Valbonne - FRANCE
Tel.: +33 4 92 94 42 00 Fax: +33 4 93 65 47 16

Internet

<http://www.3gpp.org>

Contents

| | |
|---|----|
| Intellectual Property Rights | 8 |
| Foreword | 8 |
| 1 Scope..... | 9 |
| 2 References | 9 |
| 3 Definitions, symbols, and abbreviations..... | 9 |
| 4 Frequency bands and channel arrangement..... | 10 |
| 4.1 General..... | 10 |
| 4.2 Frequency bands | 10 |
| 4.3 TX–RX frequency separation | 10 |
| 4.4 Channel arrangement | 11 |
| 4.4.1 Channel spacing | 11 |
| 4.4.2 Channel raster..... | 11 |
| 4.4.3 Channel number | 11 |
| 5 General test conditions and declarations | 12 |
| 5.1 Base station classes..... | 12 |
| 5.2 Output power and determination of power class..... | 12 |
| 5.3 Specified frequency range..... | 12 |
| 5.4 Test environments | 12 |
| 5.4.1 Normal test environment | 12 |
| 5.4.2 Extreme test environment..... | 13 |
| 5.4.2.1 Extreme temperature..... | 13 |
| 5.4.3 Vibration | 14 |
| 5.4.4 Power supply | 14 |
| 5.4.5 Acceptable uncertainty of measurement equipment | 14 |
| 5.5 Interpretation of measurement results | 17 |
| 5.6 Selection of configurations for testing | 18 |
| 5.7 BS Configurations..... | 18 |
| 5.7.1 Receiver diversity..... | 18 |
| 5.7.2 Duplexers | 18 |
| 5.7.3 Power supply options | 18 |
| 5.7.4 Ancillary RF amplifiers..... | 19 |
| 5.7.5 BS using antenna arrays | 19 |
| 5.8 Overview of the conformance test requirements..... | 20 |
| 5.9 Format and interpretation of tests | 22 |
| 6 Transmitter characteristics..... | 22 |
| 6.1 General..... | 22 |
| 6.2 Maximum output power..... | 23 |
| 6.2.1 Definition and applicability..... | 23 |
| 6.2.2 Conformance requirements | 23 |
| 6.2.3 Test purpose | 23 |
| 6.2.4 Method of test | 23 |
| 6.2.4.1 Initial conditions | 23 |
| 6.2.4.2 Procedure..... | 23 |
| 6.2.5 Test requirements | 24 |
| 6.3 Frequency stability..... | 24 |
| 6.3.1 Definition and applicability..... | 24 |
| 6.3.2 Conformance requirements | 24 |
| 6.3.3 Test purpose | 24 |
| 6.3.4 Method of test | 24 |
| 6.3.4.1 Initial conditions | 24 |
| 6.3.4.2 Procedure..... | 25 |

| | | |
|-----------|--|----|
| 6.3.5 | Test requirements | 25 |
| 6.4 | Output power dynamics | 25 |
| 6.4.1 | Inner loop power control | 25 |
| 6.4.2 | Power control steps | 25 |
| 6.4.2.1 | Definition and applicability | 25 |
| 6.4.2.2 | Conformance requirements | 25 |
| 6.4.2.3 | Test purpose | 25 |
| 6.4.2.4 | Method of test..... | 26 |
| 6.4.2.4.1 | Initial conditions | 26 |
| 6.4.2.4.2 | Procedure | 26 |
| 6.4.2.5 | Test requirements | 27 |
| 6.4.3 | Power control dynamic range..... | 27 |
| 6.4.3.1 | Definition and applicability | 27 |
| 6.4.3.2 | Conformance requirements..... | 27 |
| 6.4.3.3 | Test purpose | 27 |
| 6.4.3.4 | Method of test..... | 27 |
| 6.4.3.4.1 | Initial conditions | 27 |
| 6.4.3.4.2 | Procedure | 28 |
| 6.4.3.5 | Test requirements | 28 |
| 6.4.4 | Minimum transmit power | 28 |
| 6.4.4.1 | Definition and applicability | 28 |
| 6.4.4.2 | Conformance requirements..... | 29 |
| 6.4.4.3 | Test purpose | 29 |
| 6.4.4.4 | Method of test..... | 29 |
| 6.4.4.4.1 | Initial conditions | 29 |
| 6.4.4.4.2 | Procedure | 29 |
| 6.4.4.5 | Test requirements | 30 |
| 6.4.5 | Primary CCPCH power..... | 30 |
| 6.4.5.1 | Definition and applicability | 30 |
| 6.4.5.2 | Conformance requirements..... | 30 |
| 6.4.5.3 | Test purpose | 30 |
| 6.4.5.4 | Method of test..... | 30 |
| 6.4.5.4.1 | Initial conditions | 30 |
| 6.4.5.4.2 | Procedure | 31 |
| 6.4.5.5 | Test requirements | 31 |
| 6.5 | Transmit OFF power..... | 31 |
| 6.5.1 | Definition and applicability..... | 31 |
| 6.5.2 | Conformance requirements | 31 |
| 6.5.3 | Test purpose | 31 |
| 6.5.4 | Method of test | 31 |
| 6.5.4.1 | Initial conditions | 31 |
| 6.5.4.2 | Procedure..... | 32 |
| 6.5.5 | Test requirements | 32 |
| 6.6 | Output RF spectrum emissions | 32 |
| 6.6.1 | Occupied bandwidth..... | 32 |
| 6.6.1.1 | Definition and applicability | 32 |
| 6.6.1.2 | Conformance requirements..... | 32 |
| 6.6.1.3 | Test purpose | 32 |
| 6.6.1.4 | Method of test..... | 33 |
| 6.6.1.4.1 | Initial conditions | 33 |
| 6.6.1.4.2 | Procedure | 33 |
| 6.6.1.5 | Test requirements | 33 |
| 6.6.2 | Out of band emission..... | 33 |
| 6.6.2.1 | Spectrum emission mask..... | 33 |
| 6.6.2.1.1 | Test purpose..... | 34 |
| 6.6.2.1.2 | Test case..... | 34 |
| 6.6.2.1.3 | Conformance requirements | 34 |
| 6.6.2.2 | Adjacent Channel Leakage power Ratio (ACLR)..... | 34 |
| 6.6.2.2.1 | Definition and applicability..... | 34 |

| | | |
|-------------|--|----|
| 6.6.2.2.2 | Conformance requirements | 34 |
| 6.6.2.2.3 | Test purpose..... | 34 |
| 6.6.2.2.4 | Method of test | 34 |
| 6.6.2.2.4.1 | Initial conditions..... | 34 |
| 6.6.2.2.4.2 | Procedure | 35 |
| 6.6.2.2.5 | Test requirements..... | 35 |
| 6.6.2.3 | Protection outside a licensee's frequency block..... | 35 |
| 6.6.2.3.1 | Test purpose..... | 35 |
| 6.6.2.3.2 | Test case..... | 35 |
| 6.6.2.3.3 | Conformance requirements | 35 |
| 6.6.3 | Spurious emissions | 36 |
| 6.6.3.1 | Definition and applicability | 36 |
| 6.6.3.2 | Conformance requirements..... | 36 |
| 6.6.3.2.1 | Mandatory requirements | 36 |
| 6.6.3.2.1.1 | Spurious emissions (Category A)..... | 36 |
| 6.6.3.2.1.2 | Spurious emissions (Category B)..... | 36 |
| 6.6.3.2.2 | Co-existence with GSM | 37 |
| 6.6.3.2.2.1 | Operation in the same geographic area..... | 37 |
| 6.6.3.2.2.2 | Co-located base stations | 37 |
| 6.6.3.2.3 | Co-existence with DCS 1800..... | 37 |
| 6.6.3.2.3.1 | Operation in the same geographic area..... | 37 |
| 6.6.3.2.3.2 | Co-located base stations | 38 |
| 6.6.3.3 | Test purpose | 38 |
| 6.6.3.4 | Method of test..... | 38 |
| 6.6.3.4.1 | Initial conditions | 38 |
| 6.6.3.4.2 | Procedure | 38 |
| 6.6.3.5 | Test requirements | 38 |
| 6.7 | Transmit intermodulation..... | 39 |
| 6.7.1 | Definition and applicability..... | 39 |
| 6.7.2 | Conformance requirements | 39 |
| 6.7.3 | Test purpose | 39 |
| 6.7.4 | Method of test | 39 |
| 6.7.4.1 | Initial conditions | 39 |
| 6.7.4.2 | Procedure..... | 40 |
| 6.7.5 | Test requirements | 40 |
| 6.8 | Transmit Modulation | 40 |
| 6.8.1 | Modulation accuracy | 40 |
| 6.8.1.1 | Definition and applicability | 40 |
| 6.8.1.2 | Conformance requirements..... | 41 |
| 6.8.1.3 | Test purpose | 41 |
| 6.8.1.4 | Method of test..... | 41 |
| 6.8.1.4.1 | Initial conditions | 41 |
| 6.8.1.4.2 | Procedure | 41 |
| 6.8.1.5 | Test requirements | 41 |
| 6.8.2 | Peak code domain error..... | 41 |
| 6.8.2.1 | Definition and applicability | 41 |
| 6.8.2.2 | Conformance requirements..... | 41 |
| 6.8.2.3 | Test purpose | 42 |
| 6.8.2.4 | Method of test..... | 42 |
| 6.8.2.4.1 | Initial conditions | 42 |
| 6.8.2.4.2 | Procedure | 42 |
| 6.8.2.5 | Test requirements | 42 |
| 7 | Receiver characteristics | 43 |
| 7.1 | General..... | 43 |
| 7.2 | Reference sensitivity level | 43 |
| 7.2.1 | Definition and applicability..... | 43 |
| 7.2.2 | Conformance requirements | 43 |
| 7.2.3 | Test purpose | 43 |

| | | |
|-----------|--|----|
| 7.2.4 | Method of test | 43 |
| 7.2.4.1 | Initial conditions | 43 |
| 7.2.4.2 | Procedure | 44 |
| 7.2.5 | Test requirements | 44 |
| 7.3 | Dynamic range | 44 |
| 7.3.1 | Definition and applicability | 44 |
| 7.3.2 | Conformance requirements | 44 |
| 7.3.3 | Test purpose | 44 |
| 7.3.4 | Method of test | 44 |
| 7.3.4.1 | Initial conditions | 44 |
| 7.3.4.2 | Procedure | 44 |
| 7.3.5 | Test requirements | 45 |
| 7.4 | Adjacent Channel Selectivity (ACS) | 45 |
| 7.4.1 | Definition and applicability | 45 |
| 7.4.2 | Conformance requirements | 45 |
| 7.4.3 | Test purpose | 45 |
| 7.4.4 | Method of test | 45 |
| 7.4.4.1 | Initial conditions | 45 |
| 7.4.4.2 | Procedure | 46 |
| 7.4.5 | Test requirements | 46 |
| 7.5 | Blocking characteristics | 46 |
| 7.5.1 | Definition and applicability | 46 |
| 7.5.2 | Conformance requirements | 46 |
| 7.5.3 | Test purpose | 46 |
| 7.5.4 | Method of test | 47 |
| 7.5.4.1 | Initial conditions | 47 |
| 7.5.4.2 | Procedure | 47 |
| 7.5.5 | Test requirements | 47 |
| 7.6 | Intermodulation characteristics | 47 |
| 7.6.1 | Definition and applicability | 47 |
| 7.6.2 | Conformance requirements | 48 |
| 7.6.3 | Test purpose | 48 |
| 7.6.4 | Method of test | 48 |
| 7.6.4.1 | Initial conditions | 48 |
| 7.6.4.2 | Procedure | 48 |
| 7.6.5 | Test requirements | 49 |
| 7.7 | Spurious emissions | 49 |
| 7.7.1 | Definition and applicability | 49 |
| 7.7.2 | Conformance requirements | 49 |
| 7.7.3 | Test purpose | 49 |
| 7.7.4 | Method of test | 49 |
| 7.7.4.1 | Initial conditions | 49 |
| 7.7.4.2 | Procedure | 49 |
| 7.7.5 | Test requirements | 50 |
| 8 | Performance requirements | 51 |
| 8.1 | General | 51 |
| 8.2 | Demodulation in static propagation conditions | 51 |
| 8.2.1 | Demodulation of DCH | 51 |
| 8.2.1.1 | Definition and applicability | 51 |
| 8.2.1.2 | Conformance requirements | 51 |
| 8.2.1.3 | Test purpose | 52 |
| 8.2.1.4 | Method of test | 52 |
| 8.2.1.4.1 | Initial conditions | 52 |
| 8.2.1.4.2 | Procedure | 52 |
| 8.2.1.5 | Test requirements | 52 |
| 8.3 | Demodulation of DCH in multipath fading conditions | 52 |
| 8.3.1 | Multipath fading Case 1 | 52 |
| 8.3.1.1 | Definition and applicability | 52 |

| | | |
|---|---|-----------|
| 8.3.1.2 | Conformance requirements | 52 |
| 8.3.1.3 | Test purpose | 53 |
| 8.3.1.4 | Method of test | 53 |
| 8.3.1.4.1 | Initial conditions | 53 |
| 8.3.1.4.2 | Procedure | 53 |
| 8.3.1.5 | Test requirements | 53 |
| 8.3.2 | Multipath fading Case 2 | 53 |
| 8.3.2.1 | Definition and applicability | 53 |
| 8.3.2.2 | Conformance requirements | 54 |
| 8.3.2.3 | Test purpose | 54 |
| 8.3.2.4 | Method of test | 54 |
| 8.3.2.4.1 | Initial conditions | 54 |
| 8.3.2.4.2 | Procedure | 54 |
| 8.3.2.5 | Test requirements | 54 |
| 8.3.3 | Multipath fading Case 3 | 54 |
| 8.3.3.1 | Definition and applicability | 54 |
| 8.3.3.2 | Conformance requirements | 55 |
| 8.3.3.3 | Test purpose | 55 |
| 8.3.3.4 | Method of test | 55 |
| 8.3.3.4.1 | Initial conditions | 55 |
| 8.3.3.4.2 | Procedure | 55 |
| 8.3.3.5 | Test requirements | 55 |
| Annex A (normative): Measurement Channels | | 56 |
| A.1 | General | 56 |
| A.2 | Reference measurement channel | 56 |
| A.2.1 | UL reference measurement channel (12.2 kbps) | 56 |
| A.2.2 | UL reference measurement channel (64 kbps) | 57 |
| A.2.3 | UL reference measurement channel (144 kbps) | 58 |
| A.2.4 | UL reference measurement channel (384 kbps) | 59 |
| A.2.5 | RACH reference measurement channel | 60 |
| A.2.5.1 | RACH mapped to 1 code SF16 | 60 |
| A.2.5.2 | RACH mapped to 1 code SF8 | 61 |
| Annex B (normative): Propagation conditions | | 62 |
| B.1 | Static propagation condition | 62 |
| B.2 | Multi-path fading propagation conditions | 62 |
| Annex C (normative): Global in-channel Tx test | | 63 |
| C.1 | General | 63 |
| C.2 | Definition of the process | 63 |
| C.2.1 | Basic principle | 63 |
| C.2.2 | Output signal of the Tx under test | 63 |
| C.2.3 | Reference signal | 63 |
| C.2.4 | Provisions in case of multi code signals | 64 |
| C.2.5 | Classification of measurement results | 64 |
| C.2.6 | Process definition to achieve results of type 1 | 64 |
| C.2.7 | Process definition to achieve results of type 2 | 65 |
| C.2.7.1 | Error Vector Magnitude | 65 |
| C.2.7.2 | Peak Code Domain Power Error | 66 |
| C.3 | Applications | 67 |
| History | | 68 |

Intellectual Property Rights

IPRs essential or potentially essential to the present deliverable may have been declared to 3GPP and/or its organizational partners. The information pertaining to these essential IPRs, if any, is publicly available for **3GPP members and non-members, free of charge**. This can be found in the latest version of the 3GPP Technical Report:

Pursuant to the 3GPP Interim IPR Policy, no investigation, including IPR searches, has been carried out by 3GPP. No guarantee can be given as to the existence of other IPRs not referenced in the [tbd.], which are, or may be, or may become, essential to the present document.

Foreword

This Technical Specification has been produced by the 3GPP.

The contents of the present document are subject to continuing work within the TSG and may change following formal TSG approval. Should the TSG modify the contents of this TS, it will be re-released by the TSG with an identifying change of release date and an increase in version number as follows:

Version x.y.z

where:

- x the first digit:
 - 1 presented to TSG for information;
 - 2 presented to TSG for approval;
 - 3 Indicates TSG approved document under change control.
- y the second digit is incremented for all changes of substance, i.e. technical enhancements, corrections, updates, etc.
- z the third digit is incremented when editorial only changes have been incorporated in the specification.

1 Scope

The present document specifies the Radio Frequency (RF) test methods and conformance requirements for UTRA Base Stations (BS) operating in the TDD mode. These have been derived from, and are consistent with, the UTRA base station (BS) specifications defined in 3G TS 25.105 [1].

In this TS, the reference point for RF connections (except for the measurement of mean transmitted RF carrier power) is the antenna connector, as defined by the manufacturer. This TS does not apply to repeaters or RF devices which may be connected to an antenna connector of a BS.

2 References

The following documents contain provisions which, through reference in this text, constitute provisions of the present document.

- References are either specific (identified by date of publication, edition number, version number, etc.) or non-specific.
- For a specific reference, subsequent revisions do not apply.
- For a non-specific reference, the latest version applies.
- A non-specific reference to an ETS shall also be taken to refer to later versions published as an EN with the same number.

- [1] 3G TS 25.105: " UTRA (BS) TDD; Radio transmission and Reception ".
- [2] ETR 027: "Methods of measurement for mobile radio equipment".
- [3] IEC 721: "Classification of environmental conditions".
- [4] IEC 68-2: "Basic environmental testing procedures; Part 2: Tests".
- [5] ETR 028: "Uncertainties in the measurement of mobile radio equipment characteristics".
- [6] Recommendation ITU-R SM.329-7: "Spurious emissions".
- [7] Recommendation ITU-R SM.328-9: "Spectra and bandwidth of emissions".
- [8] ETS 300 019-1: "Equipment Engineering (EE); Environmental conditions and environmental tests for telecommunications equipment Part 1-0: Classification of environmental conditions Introduction".

3 Definitions, symbols, and abbreviations

For the purposes of the present document, the following definitions, symbols and abbreviations apply:

| | |
|-------------------------------|---|
| 3GPP | 3rd Generation Partnership Project |
| α | Roll-off factor |
| dB | decibel |
| dBm | decibel relative to 1 milliWatt |
| DPCH _o | Mechanism used to simulate an individual intracell interferer in the cell with one code and a spreading factor of 16 |
| $\frac{DPCH_o - E_c}{I_{or}}$ | Ratio of the average transmit energy per PN chip for the DPCH _o to the total transmit power |
| EVM | spectral density of all users in the cell in one timeslot as measured at the BS antenna connector Error Vector Magnitude |

| | |
|-------------------------|---|
| F | Frequency (of the assigned channel frequency of the wanted signal) |
| F _w | Frequency offset of the unwanted interfering signal from the assigned channel frequency of the wanted signal |
| IMT-2000 | International Mobile Telecommunications 2000 |
| I _{oc} | Power spectral density of a band limited white noise source (simulating interference from other cells) as measured at the BS antenna connector. |
| \hat{I} _{or} | Received power spectral density of all users in the cell in one timeslot as measured at the BS antenna connector |
| IPR | Intellectual Property Rights |
| P | Transmit power |
| P _{out} | Output power |
| P _{max} | Maximum output power |
| RBER | Residual BER |
| REFSENS | Reference Sensitivity Level |
| RMS | Root-Mean Square |
| RRC | Root-Raised Cosine |
| T _c | Chip duration |
| TS | Time Slot |

4 Frequency bands and channel arrangement

4.1 General

The information presented in this section is based on a chip rate of 3,84 Mcps.

NOTE: Other chip rates may be considered in future releases.

4.2 Frequency bands

UTRA/TDD is designed to operate in the following bands:

- a) 1900 – 1920 MHz: Uplink and downlink transmission
2010 – 2025 MHz Uplink and downlink transmission
- b)* 1850 – 1910 MHz: Uplink and downlink transmission
1930 – 1990 MHz: Uplink and downlink transmission
- c)* 1910 – 1930 MHz: Uplink and downlink transmission

* Used in ITU Region 2

Additional allocations in ITU region 2 are FFS.

Deployment in existing and other frequency bands is not precluded.

The co-existence of TDD and FDD in the same bands is still under study in WG4.

4.3 TX–RX frequency separation

No TX-RX frequency separation is required as Time Division Duplex (TDD) is employed. Each TDMA frame consists of 15 timeslots where each timeslot can be allocated to either transmit or receive.

4.4 Channel arrangement

4.4.1 Channel spacing

The nominal channel spacing is 5 MHz, but this can be adjusted to optimize performance in a particular deployment scenario.

4.4.2 Channel raster

The channel raster is 200 kHz, which means that the carrier frequency must be a multiple of 200 kHz.

4.4.3 Channel number

The carrier frequency is designated by the UTRA absolute radio frequency channel number (UARFCN). The value of the UARFCN in the IMT2000 band is defined as follows:

$$N_t = 5 * F \text{ MHz} \quad 0,0 \leq F \leq 3276,6 \text{ MHz} \quad \text{where } F \text{ is the carrier frequency in MHz}$$

5 General test conditions and declarations

The requirements of this clause apply to all tests in this TS, when applicable.

The general conditions during the tests should be according to the relevant parts of ETR 027 [2] (methods of measurement for mobile radio equipment) with the exceptions and additions defined in the individual tests.

Many of the tests in this TS measure a parameter relative to a value which is not fully specified in the UTRA specifications. For these tests, the conformance requirement is determined relative to a nominal value specified by the manufacturer.

Certain functions of a BS are optional in the UTRA specifications.

When specified in a test, the manufacturer shall declare the nominal value of a parameter, or whether an option is supported.

5.1 Base station classes

The requirements in this specification apply to base stations intended for general-purpose applications in co-ordinated network operation.

In future, further classes of base stations may be defined; the requirements for these may be different than for general-purpose applications.

5.2 Output power and determination of power class

The manufacturer shall declare the maximum output power of the base station which is defined as the mean power level per carrier at the antenna connector; see subclause 6.2.

5.3 Specified frequency range

The manufacturer shall declare:

- which of the frequency bands defined in sub-clause 4.2 is supported by the BS.
- the frequency range within the above frequency band(s) supported by the BS. As TDD is employed, the same frequency range is used for transmit and receive operation.

Many tests in this TS are performed with appropriate frequencies in the bottom, middle and top of the operating frequency band of the BS. These are denoted as RF channels B (bottom), M (middle) and T (top).

When a test is performed by a test laboratory, the UARFCNs to be used for RF channels B, M and T shall be specified by the laboratory. The laboratory may consult with operators, the manufacturer or other bodies.

When a test is performed by a manufacturer, the UARFCNs to be used for RF channels B, M and T may be specified by an operator.

5.4 Test environments

For each test in this TS, the environmental conditions under which the BS is to be tested are defined.

5.4.1 Normal test environment

When a normal test environment is specified for a test, the test should be performed under any combination of conditions between the minimum and maximum limits stated in table 5.4.1.1.

Table 5.4.1.1: Limits of conditions for Normal Test Environment

| Condition | Minimum | Maximum |
|---------------------|--|---------|
| Barometric pressure | 86 kPa | 106 kPa |
| Temperature | 15°C | 30°C |
| Relative Humidity | 20 % | 85 % |
| Power supply | Nominal, as declared by the manufacturer | |
| Vibration | Negligible | |

The ranges of barometric pressure, temperature and humidity represent the maximum variation expected in the uncontrolled environment of a test laboratory. If it is not possible to maintain these parameters within the specified limits, the actual values shall be recorded in the test report.

NOTE: This may, for instance, be the case for measurements of radiated emissions performed on an open field test site.

5.4.2 Extreme test environment

The manufacturer shall declare one of the following:

- The equipment class for the equipment under test, as defined in ETS 300 019-1-3, (Equipment Engineering (EE); Environmental conditions and environmental test for telecommunications equipment, Part 1-3: Classification of environmental conditions, Stationary use at weather protected locations).
- The equipment class for the equipment under test, as defined in ETS 300 019-1-4, (Equipment Engineering (EE); Environmental conditions and environmental test for telecommunications equipment, Part 1-4: Classification of environmental conditions, Stationary use at non-weather protected locations).
- For equipment that does not comply to an ETS 300 019-1 [8] class, the relevant classes from IEC 721 [3] documentation for Temperature, Humidity and Vibration shall be declared.

NOTE: Reduced functionality for conditions that fall out side of the standard operational conditions are not tested in this TS. These may be stated and tested separately.

5.4.2.1 Extreme temperature

When an extreme temperature test environment is specified for a test, the test shall be performed at the standard minimum and maximum operating temperatures defined by the manufacturer's declaration for the equipment under test.

Minimum temperature:

The test shall be performed with the environmental test equipment and methods of inducing the required environmental phenomena into the equipment, conforming to the test procedure of IEC 68-2-1 [4], Environmental Testing, Part 2: Tests - Tests A: Cold. The equipment shall be maintained at the stabilized condition for the duration of the test sequence.

Maximum temperature:

The test shall be performed with the environmental test equipment and methods of inducing the required environmental phenomena in to the equipment, conforming to the test procedure of IEC 68-2-2 [4] (Environmental Testing, Part 2: Tests - Tests Bd Dry heat). The equipment shall be maintained at the stabilized condition for the duration of the test sequence.

NOTE: It is recommended that the equipment is made fully operational prior to the equipment being taken to its lower operating temperature.

5.4.3 Vibration

When vibration conditions are specified for a test, the test shall be performed while the equipment is subjected to a vibration sequence as defined by the manufacturers declaration for the equipment under test. This shall use the environmental test equipment and methods of inducing the required environmental phenomena in to the equipment, conforming to the test procedure of IEC 68-2-6 [4], Environmental Testing, Part 2: Tests - Test Fc and guidance: Vibration (Sinusoidal). Other environmental conditions shall be within the ranges specified in subclause 5.4.1, Normal test environment.

NOTE: The higher levels of vibration may induce undue physical stress in to equipment after a prolonged series of tests. The testing body should only vibrate the equipment during the RF measurement process.

5.4.4 Power supply

When extreme power supply conditions are specified for a test, the test shall be performed at the standard upper and lower limits of operating voltage defined by the manufacturer's declaration for the equipment under test.

Upper voltage limit

The equipment shall be supplied with a voltage equal to the upper limit declared by the manufacturer (as measured at the input terminals to the equipment). The tests shall be carried out at a steady state minimum and maximum limit declared by the manufacturer for the equipment, to the methods described in IEC 68-2-1 [4] Test Ab/Ad: Cold and IEC 68-2-2 Test Bb/Bd: Dry Heat.

Lower voltage limit

The equipment shall be supplied with a voltage equal to the lower limit declared by the manufacturer (as measured at the input terminals to the equipment). The tests shall be carried out at a steady state minimum and maximum limit declared by the manufacturer for the equipment, to the methods described in IEC 68-2-1 [4] Test Ab/Ad: Cold and IEC 68-2-2 [4] Test Bb/Bd: Dry Heat.

5.4.5 Acceptable uncertainty of measurement equipment

The maximum acceptable uncertainty of measurement equipment is specified separately for each test, where appropriate. The measurement equipment shall enable the stimulus signals in the test case to be adjusted to within the specified tolerance, and the conformance requirement to be measured with an uncertainty not exceeding the specified values. All tolerances and uncertainties are absolute values, unless otherwise stated.

Subclause 5.4, Test environments:

| | |
|---------------------|-----------------|
| Pressure | ± 5 kPa |
| Temperature | ± 2 degrees |
| Relative Humidity | ± 5 % |
| DC Voltage | $\pm 1,0$ % |
| AC Voltage | $\pm 1,5$ % |
| Vibration | 10 % |
| Vibration frequency | 0,1 Hz |

The above values shall apply unless the test environment is controlled and the specification for the control of the test environment specifies the uncertainty for the parameter.

Transmitter

Subclause 6.2, Base station maximum output power:

Conformance requirement:

RF power, for static power step 0 $\pm 1,0$ dB

Subclause 6.3, Frequency stability:

Conformance requirement:

Frequency ± 10 Hz

Subclause 6.4, Output power dynamics

Conformance requirement:

RF power, for static power steps (minimum and maximum Tx power) $\pm 1,0$ dB

Relative RF Power $\pm 0,7$ dB

Subclause 6.5, Transmit OFF power:

Conformance requirement:

RF power difference

Power difference < 50 dB $\pm 0,7$ dB

Power difference ≥ 50 dB $\pm 1,5$ dB

Subclause 6.6, Output RF spectrum emissions

Conformance requirement:

RF power difference

Power difference < 50 dB $\pm 0,7$ dB

Power difference ≥ 50 dB $\pm 1,5$ dB

Relative RF power:

Table 5.4.5.1: Acceptable uncertainty of relative RF power measurements

| Offset from carrier, MHz | Power difference, dB | Uncertainty of relative power, dB |
|--------------------------|----------------------|-----------------------------------|
| | | |
| | | |
| | | |

Spurious emissions

RF power

- inside the BS transmit band ± 1.5 dB

- outside the BS transmit band:

| | |
|--------------------------|--------------|
| $f \leq 2$ GHz | ± 1.5 dB |
| 2 GHz $< f \leq 4$ GHz | ± 2.0 dB |
| $f > 4$ GHz | ± 4.0 dB |

Subclause 6.7, Transmit intermodulation:

Test case:

Relative RF power (of injected signal) ± 1.5 dB

Conformance requirement (outside RX band):

| | |
|---------------------------------|--------------|
| RF power; absolute limit values | ± 1.5 dB |
| RF power, relative measurements | ± 2.0 dB |

Conformance requirement (inside RX band):

RF power; absolute limit values $+4$ dB -3 dB

NOTE: The positive limit for uncertainty is greater than the negative limit because the measurement result can be increased (but not decreased) due to intermodulation products within the measurement apparatus.

Receiver

Where a measurement uncertainty of $+5$ dB -0 dB is specified for an input signal, the measured value of the input signal should be increased by an amount equal to the uncertainty with which it can be measured. This will ensure that the true value of the input signal is not below the specified nominal.

Subclause 7.2, Reference sensitivity level

Test case:

RF power ± 1.0 dB

Subclause 7.3, Dynamic range:

Test case:

| | |
|-------------------|--------------|
| RF power | ± 1.5 dB |
| Relative RF power | ± 3.0 dB |

Subclause 7.4, Adjacent Channel Selectivity (ACS):

Test case:

| | |
|-------------------|--------------|
| RF power | ± 1.5 dB |
| Relative RF power | ± 3.0 dB |

Subclause 7.5, Blocking characteristics:

Test case:

| | |
|-------------------------------|--------------|
| RF power, wanted signal | ± 1.0 dB |
| RF power, interfering signal; | |
| $f \leq 2$ GHz | ± 0.7 dB |
| 2 GHz $< f \leq 4$ GHz | ± 1.5 dB |
| $f > 4$ GHz | ± 3.0 dB |

Subclause 7.6, Intermodulation characteristics:

Test case:

| | |
|-------------------------------|--------------|
| RF power, wanted signal | ± 1.0 dB |
| RF power, interfering signals | ± 0.7 dB |

Subclause 7.7, Spurious emissions:

Conformance requirement:

| | |
|--------------------------|--------------|
| RF power; | |
| $f \leq 2$ GHz | ± 1.5 dB |
| 2 GHz $< f \leq 4$ GHz | ± 2.0 dB |
| $f > 4$ GHz | ± 4.0 dB |

5.5 Interpretation of measurement results

The requirements given in these specifications are absolute. Compliance with the requirement is determined by comparing the measured value with the specified limit, without making allowance for measurement uncertainty.

The measurement uncertainty for the measurement of each parameter shall be included in the test report.

The recorded value for the measurement uncertainty shall be, for each measurement, equal to or lower than the appropriate figure in subclause 5.4 of this TS.

NOTE: This procedure is recommended in ETR 028 [5].

If the measurement apparatus for a test is known to have a measurement uncertainty greater than that specified in subclause 5.4, it is still permitted to use this apparatus provided that an adjustment is made to the measured value as follows:

The adjustment is made by subtracting the modulus of the specified measurement uncertainty in subclause 4.7 from the measurement uncertainty of the apparatus. The measured value is then increased or decreased by the result of the subtraction, whichever is most unfavourable in relation to the limit.

5.6 Selection of configurations for testing

Most tests in this TS are only performed for a subset of the possible combinations of test conditions. For instance:

- Not all TRXs in the configuration may be specified to be tested.
- Only one RF channel may be specified to be tested.
- Only one timeslot may be specified to be tested.

When a test is performed by a test laboratory, the choice of which combinations are to be tested shall be specified by the laboratory. The laboratory may consult with operators, the manufacturer or other bodies.

When a test is performed by a manufacturer, the choice of which combinations are to be tested may be specified by an operator.

5.7 BS Configurations

This TS has been written to specify tests for the standard configurations of BS which have been assumed in UTRA requirements specifications, in particular TS 25.105 " UTRA (BS) TDD; Radio transmission and Reception " [1]. However, there are other configurations of BS which comply with these specifications, but for which the application of these specifications is not fully defined. For some such configurations there may be alternate ways to apply the requirements of this specification to testing of the configuration, or some variation in the test method may be necessary. It may therefore be necessary for the parties to the testing to reach agreement over the method of testing in advance.

If the BS is supplied in a number of different environmental enclosures or configurations, it may not be necessary to test RF parameters for each environmental configuration, provided that it can be demonstrated that the equipment has been tested at the worst internal environmental conditions.

Where alternative interpretations of this specification are possible for a BS configuration under test, the interpretation which has been adopted in performing the test shall be recorded with the test results.

Where variation in the test method within this TS has been necessary to enable a BS configuration to be tested, the variation in the test method which has been made in performing the test shall be recorded with the test results. Where possible, agreement should be reached in advance about the nature of such a variation with any party who will later receive the test results.

Possible interpretations of this TS for some common configurations are given in the following subclauses.

5.7.1 Receiver diversity

- i) For the tests in clause 7 of this TS, the specified test signals may be applied to one receiver antenna connector, with the remaining receiver antenna connectors being terminated with 50 ohms.

or

- ii) For the tests in clause 7 of this TS, the specified test signals may be simultaneously applied to each of the receiver antenna connectors.

5.7.2 Duplexers

Due to TDD operation, there is no need to use a duplexer in the BS.

5.7.3 Power supply options

If the BS is supplied with a number of different power supply configurations, it may not be necessary to test RF parameters for each of the power supply options, provided that it can be demonstrated that the range of conditions over

which the equipment is tested is at least as great as the range of conditions due to any of the power supply configurations.

This applies particularly if a BS contains a DC rail which can be supplied either externally or from an internal mains power supply. In this case, the conditions of extreme power supply for the mains power supply options can be tested by testing only the external DC supply option. The range of DC input voltages for the test should be sufficient to verify the performance with any of the power supplies, over its range of operating conditions within the BS, including variation of mains input voltage, temperature and output current.

5.7.4 Ancillary RF amplifiers

Ancillary RF amplifier: a piece of equipment, which when connected by RF coaxial cables to the BS, has the primary function to provide amplification between the transmit and/or receive antenna connector of a BS and an antenna without requiring any control signal to fulfil its amplifying function.

The requirements of this TS shall be met with the ancillary RF amplifier fitted. At tests according to clause 6 and 7 for TX and RX respectively, the ancillary amplifier is connected to the BS by a connecting network (including any cable(s), attenuator(s), etc.) with applicable loss to make sure the appropriate operating conditions of the ancillary amplifier and the BS. The applicable connecting network loss range is declared by the manufacturer. Other characteristics and the temperature dependence of the attenuation of the connecting network are neglected. The actual attenuation value of the connecting network is chosen for each test as one of the applicable extreme values. The lowest value is used unless otherwise stated.

Sufficient tests should be repeated with the ancillary amplifier fitted and, if it is optional, without the ancillary RF amplifier to verify that the BS meets the requirements of this TS in both cases.

5.7.5 BS using antenna arrays

A BS may be configured with a multiple antenna port connection for some or all of its TRXs or with an antenna array related to one cell (not one array per TRX). This subclause applies to a BS which meets at least one of the following conditions:

- The transmitter output signals from one or more TRX appear at more than one antenna port, or
- there is more than one receiver antenna port for a TRX or per cell and an input signal is required at more than one port for the correct operation of the receiver (NOTE: diversity reception does not meet this requirement) thus the outputs from the transmitters as well as the inputs to the receivers are directly connected to several antennas (known as "aircombining"), or
- transmitters and receivers are connected via duplexers to more than one antenna

If a BS is used, in normal operation, in conjunction with an antenna system which contains filters or active elements which are necessary to meet the UTRA requirements, the tests of conformance may be performed on a system comprising the BS together with these elements, supplied separately for the purposes of testing. In this case, it must be demonstrated that the performance of the configuration under test is representative of the system in normal operation, and the conformance assessment is only applicable when the BS is used with the antenna system.

For testing of conformance of such a BS, the following procedure may be used:

Receiver tests

For each test, the test signals applied to the receiver antenna connectors shall be such that the sum of the powers of the signals applied equals the power of the test signal(s) specified in the test.

An example of a suitable test configuration is shown in figure 5.7.5.1.

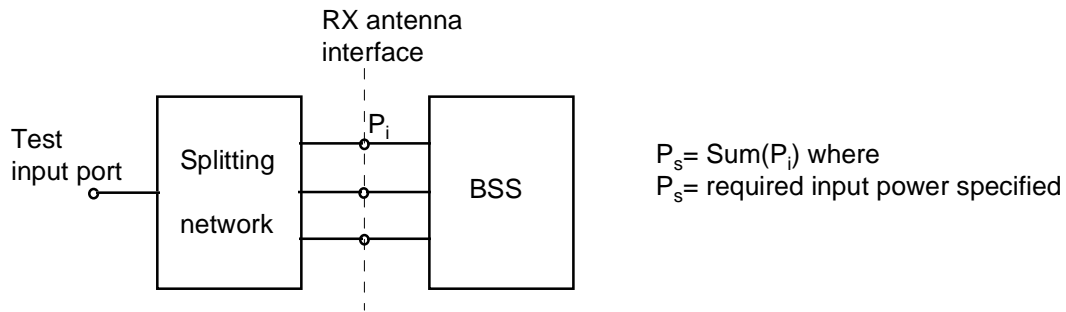

Figure 5.7.5.1: Receiver test setup

For spurious emissions from the receiver antenna connector, the test may be performed separately for each receiver antenna connector.

Transmitter tests

For each test, the conformance requirement shall be met by the sum of the signals emitted by each transmitter antenna connector. This may be assessed by separately measuring the signals emitted by each antenna connector and summing the results, or by combining the signals and performing a single measurement. The characteristics (e.g. amplitude and phase) of the combining network should be such that the power of the combined signal is maximised.

An example of a suitable test configuration is shown in figure 5.7.5.2.

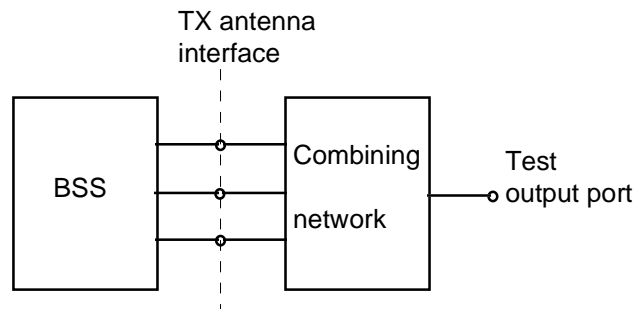

Figure 5.7.5.2: Transmitter test setup

For Intermodulation attenuation, the test may be performed separately for each transmitter antenna connector.

5.8 Overview of the conformance test requirements

Tables 5.8.1, 5.8.2 and 5.8.3 give an overview of the conformance test requirements for the transmitter, the receiver and system performance, respectively.

Table 5.8.1: Overview of the conformance tests requirements for the transmitter

| Requirement specified in reference TS [1] | | Sub-clause of Conformance Test TS |
|---|-------------------|-----------------------------------|
| Name | Sub-clause of [1] | |
| | | |
| Base station output power | 6.2 | |
| Frequency stability | 6.3 | |
| Output power dynamics | 6.4 | |
| Inner loop power control | 6.4.1 | |
| Power control steps | 6.4.2 | |
| Power control dynamic range | 6.4.3 | |
| Minimum transmit power | 6.4.4 | |
| Primary CCPCH power | 6.4.5. | |
| Transmit OFF power | 6.5 | |
| Output RF spectrum emissions | 6.6 | |
| Occupied bandwidth | 6.6.1 | |
| Out-of-band emission | 6.6.2 | |
| Spectrum emission mask | 6.6.2.1 | |
| Adjacent Channel Leakage power Ratio (ACLR) | 6.6.2.2 | |
| Protection outside a licensee's frequency block | 6.6.2.3 | |
| Spurious emissions | 6.6.3 | |
| Mandatory requirements | 6.6.3.1 | |
| Co-existence with GSM 900 | 6.6.3.2 | |
| Co-existence with DCS 1800 | 6.6.3.3 | |
| Transmit intermodulation | 6.7 | |
| Modulation accuracy | 6.8 | |

Table 5.8.2: Overview of the conformance tests requirements for the receiver

| Requirement specified in reference TS [1] | | Sub-clause of Conformance Test TS |
|---|-------------------|-----------------------------------|
| Name | Sub-clause of [1] | |
| | | |
| Reference sensitivity level | 7.2 | |
| | | |
| Dynamic range | 7.3 | |
| Adjacent Channel Selectivity (ACS) | 7.4 | |
| Blocking characteristics | 7.5 | |
| Intermodulation characteristics | 7.6 | |
| Spurious emissions | 7.7 | |
| | | |

Table 5.8.3: Overview of the conformance test requirements for system performance

| Requirement specified in reference TS [1] | | Sub-clause of Conformance Test TS |
|--|-------------------|-----------------------------------|
| Name | Sub-clause of [1] | |
| Demodulation in static propagation conditions | 8.2 | |
| Demodulation of DCH | 8.2.1 | |
| Demodulation of DCH in multipath fading conditions | 8.3 | |
| Multipath fading Case 1 | 8.3.1 | |
| Multipath fading Case 2 | 8.3.2 | |
| Multipath fading Case 3 | 8.3.3 | |
| | | |
| | | |
| | | |

5.9 Format and interpretation of tests

Each test in the following clauses has a standard format:

X Title

X.1 Test purpose

This subclause defines the purpose of the test.

X.2 Test case

This subclause describes the steps necessary to perform the test. The general test conditions described in clause 5 also apply.

X.3 Conformance requirements

This subclause describes the conformance requirements necessary to ensure compatibility and to verify the important aspects of the transmission quality of the system. This subclause is divided into two parts:

Test environment

This subclause describes the test environment or environments under which the test shall be performed. Where more than one test environment is specified, the extent of testing is specified for each environment.

Conformance requirement

This subclause describes the requirement which shall be met for the specified tests.

6 Transmitter characteristics

6.1 General

Unless otherwise stated, all measurements shall be made at the BS antenna connector.

6.2 Maximum output power

6.2.1 Definition and applicability

Output power, P_{out} , of the base station is the power of one carrier delivered to a load with resistance equal to the nominal load impedance, when averaged (in the sense of thermal power) over the useful part of the burst (time slot).

Maximum output power, P_{max} , of the base station is the output power that the manufacturer has declared to be available at the antenna connector.

The requirements in this subclause shall apply to base stations intended for general-purpose applications.

6.2.2 Conformance requirements

In normal conditions, the base station maximum output power shall remain within +2 dB and –2 dB of the available power declared by the manufacturer.

In extreme conditions, the base station maximum output power shall remain within +2,5 dB and –2,5 dB of the available power declared by the manufacturer.

The reference for this requirement is TS 25.105 subclause 6.2.1.1.

6.2.3 Test purpose

The test purpose is to verify the accuracy of the maximum output power across the frequency range and under normal and extreme conditions for all transmitters in the BS.

6.2.4 Method of test

6.2.4.1 Initial conditions

- (1) The transmitter under test and all other transmitters of the base station (if any) are switched on.
- (2) The power of the transmitters not under test (if any) are controlled down.
- (3) Connect the power measuring equipment to the BS antenna connector.
- (4) Set the parameters of the transmitted signal according to table 6.2.4.1.1.

Table 6.2.4.1.1: Parameters of the transmitted signal for maximum output power test

| Parameter | Value/description |
|----------------------------------|---|
| TDD Duty Cycle | TS i ; $i = 0, 1, 2, \dots, 14$: transmit, if i is even; receive, if i is odd. |
| Base Station output power | maximum, according to manufacturer's declaration |
| Number of DPCH in each active TS | 9 |
| Power of each DPCH | 1/9 of Base Station output power |
| Data content of DPCH | real life (sufficient irregular) |

6.2.4.2 Procedure

- (1) Measure thermal power over the 2464 active chips of an even time slot (this excludes the guard periods), and with a measurement bandwidth of at least 5 MHz.

(2) Average over TBD time slots.

(3) Run steps (1) and (2) for RF channels Low / Mid / High.

6.2.5 Test requirements

The value of the measured output power, derived according to subclause 6.2.4.2, shall be within the tolerance defined in subclause 6.2.2.

6.3 Frequency stability

6.3.1 Definition and applicability

Frequency stability is the ability of the BS to transmit at the assigned carrier frequency.

The requirements in this subclause shall apply to base stations intended for general-purpose applications.

6.3.2 Conformance requirements

The BS frequency stability shall be within $\pm 0,05$ ppm.

The reference for this requirement is TS 25.105 subclause 6.3.1.

6.3.3 Test purpose

The test purpose is to verify the accuracy of the carrier frequency across the frequency range and under normal and extreme conditions.

6.3.4 Method of test

6.3.4.1 Initial conditions

- (1) The transmitter under test and all other transmitters of the base station (if any) are switched on.
- (2) The power of the transmitters not under test (if any) are controlled down.
- (3) Connect the tester to the BS antenna connector.
- (4) Set the parameters of the transmitted signal according to table 6.3.4.1.1.

Table 6.3.4.1.1: Parameters of the transmitted signal for frequency stability test

| Parameter | Value/description |
|----------------------------------|---|
| TDD Duty Cycle | TS i ; $i = 0, 1, 2, \dots, 14$: transmit, if i is even; receive, if i is odd. |
| Number of DPCH in each active TS | 1 |
| Base Station output power | maximum, according to manufacturer's declaration |
| Data content of DPCH | real life (sufficient irregular) |

6.3.4.2 Procedure

- (1) Measure the frequency error Δf across one burst (time slot), by applying the global in-channel Tx test method described in Annex C.
- (2) Repeat step (1) for 200 bursts (time slots).
- (3) Run steps (1) and (2) for RF channels Low / Mid / High.

6.3.5 Test requirements

For all measured bursts (time slots), the frequency error, derived according to subclause 6.3.4.2, shall not exceed $0,5 \times 10E-7$.

6.4 Output power dynamics

6.4.1 Inner loop power control

Inner loop power control is the ability of the BS transmitter to adjust its output power in response to the UL received signal.

For inner loop correction on the Downlink Channel, the base station adjusts its mean output power level in response to each valid power control bit received from the UE on the Uplink Channel. Inner loop control is based on SIR measurements at the UE receiver, and the corresponding TPC commands are generated by the UE.

6.4.2 Power control steps

6.4.2.1 Definition and applicability

The power control step is the step change in the DL transmitter output power in response to a TPC message from the UE.

The requirements in this subclause shall apply to base stations intended for general-purpose applications.

6.4.2.2 Conformance requirements

The power control step sizes in the DL shall be 1 dB, 2 dB and 3 dB.

The tolerance of the transmitter output power and the greatest average rate of change in mean power due to the power control step shall be within the range shown in Table 6.4.2.2.1.

Table 6.4.2.2.1: Power control step size tolerance

| Step size | tolerance | Range of average rate of change in mean power per 10 steps | |
|-----------|---------------|--|-------------|
| | | Minimum | maximum |
| 1dB | $\pm 0,5$ dB | ± 8 dB | ± 12 dB |
| 2dB | $\pm 0,75$ dB | ± 16 dB | ± 24 dB |
| 3dB | ± 1 dB | ± 24 dB | ± 36 dB |

The reference for this requirement is TS 25.105 subclause 6.4.2.1.

6.4.2.3 Test purpose

The DL power control is applied to adjust the BS output power to a value that is sufficiently high to generate a SIR at the UE receiver equal to the target SIR, while limiting the intercell interference.

The test purpose is to verify the ability of the BS to interpret received TPC commands in a correct way and to adjust its output power according to these commands with the specified accuracy.

6.4.2.4 Method of test

6.4.2.4.1 Initial conditions

- (1) Connect the BS tester to the antenna connector of the BS under test.
- (2) Disable closed loop power control in the BS under test.
- (3) Set the initial parameters of the BS transmitted signal according to table 6.4.2.4.1.1.
- (4) Set up a call between the BS under test and the BS tester according to the generic call setup procedure.

NOTE: The BS tester used for this test must have the ability

- to analyze the output signal of the BS under test with respect to code domain power, by applying the global in-channel Tx test method described in Annex C;

- to simulate an UE with respect to the generation of TPC commands embedded in a valid UE signal.

Table 6.4.2.4.1.1: Initial parameters of the BS transmitted signal for power control steps test

| Parameter | Value/description |
|----------------------------------|---|
| TDD Duty Cycle | TS i ; $i = 0, 1, 2, \dots, 14$: transmit, if i is even; receive, if i is odd. |
| Number of DPCH in each active TS | 1 |
| DPCH power | Minimum |
| Data content of DPCH | real life (sufficient irregular) |

6.4.2.4.2 Procedure

- (1) Configure the BS transmitter to enable power control steps of size 1 dB.
- (2) Set the BS tester to produce a sequence of TPC commands related to the active DPCH. This sequence shall be transmitted to the BS within the odd time slots TS i (receive time slots of the BS) and shall consist of a series of TPC commands with content "Increase Tx power", followed by a series of TPC commands with content "Decrease Tx power". Each of these series should be sufficiently long so that the transmit output power of the active DPCH is controlled to reach its maximum and its minimum, respectively.
- (3) Measure the power of the active DPCH over the 2464 active chips of each even time slot TS i (-this excludes the guard period), and with a measurement filter that has a RRC filter response with a roll off $\alpha = 0,22$ and a bandwidth equal to the chip rate. The power is determined by calculating the RMS value of the signal samples at the measurement filter output taken at the decision points.
- (4) Based on the measurement made in step (3), calculate the power control step sizes and the average rate of change per 10 steps.
- (5) Configure the BS transmitter to enable power control steps of 2 dB and of 3 dB, respectively, and repeat steps (2) to (4).

NOTE: In case of power control step size 3 dB, the number of power control steps feasible within the power control dynamic range of the BS under test may be lower than 10. In this case, the evaluation of the average rate of change in mean power may be based on less than 10 power control steps.

6.4.2.5 Test requirements

For all measurements, the tolerance of the power control step sizes and the average rate of change per 10 steps shall be within the limits given in Table 6.4.2.2.1.

6.4.3 Power control dynamic range

6.4.3.1 Definition and applicability

The power control dynamic range is the difference between the maximum and the minimum transmit output power for a specified reference condition.

The requirements in this subclause shall apply to base stations intended for general-purpose applications.

6.4.3.2 Conformance requirements

The DL power control dynamic range shall be greater than or equal to 30 dB.

The reference for this requirement is TS 25.105 subclause 6.4.3.1.

6.4.3.3 Test purpose

The test purpose is to verify the ability of the BS to control the power of a single code signal over the specified dynamic range.

6.4.3.4 Method of test

6.4.3.4.1 Initial conditions

- (1) Connect the BS tester to the antenna connector of the BS under test.
- (2) Set the parameters of the BS transmitted signal according to table 6.4.3.4.1.1.
- (3) Set up a call between the BS under test and the BS tester according to the generic call setup procedure.

NOTE: The BS tester used for this test must have the ability

- to analyze the output signal of the BS under test with respect to code domain power, by applying the global in-channel Tx test method described in Annex C;
- to simulate an UE with respect to the generation of TPC commands embedded in a valid UE signal.

Table 6.4.3.4.1.1: Parameters of the BS transmitted signal for power control dynamic range test

| Parameter | Value/description |
|----------------------------------|---|
| TDD Duty Cycle | TS i ; $i = 0, 1, 2, \dots, 14$: transmit, if i is even; receive, if i is odd. |
| Number of DPCH in each active TS | 1 |
| Data content of DPCH | real life (sufficient irregular) |

6.4.3.4.2 Procedure

- (1) Configure the BS transmitter to enable power control steps of size 1 dB.
- (2) Set the BS tester to produce a sequence of TPC commands related to the active DPCH, with content "Increase Tx power". This sequence shall be sufficiently long so that the transmit output power of the active DPCH is controlled to reach its maximum, and shall be transmitted to the BS within the odd time slots TS i (receive time slots of the BS).
- (3) Measure the power of the active DPCH over the 2464 active chips of each even time slot TS i (this excludes the guard period), and with a measurement filter that has a RRC filter response with a roll off $\alpha = 0,22$ and a bandwidth equal to the chip rate. The power is determined by calculating the RMS value of the signal samples at the measurement filter output taken at the decision points.
- (4) Average over TBD time slots.
- (5) Set the BS tester to produce a sequence of TPC commands related to the active DPCH, with content "Decrease Tx power". This sequence shall be sufficiently long so that the transmit output power of the active DPCH is controlled to reach its minimum, and shall be transmitted to the BS within the odd time slots TS i (receive time slots of the BS).
- (6) Measure the power of the active DPCH over the 2464 active chips of each even time slot TS i (this excludes the guard period), and with a measurement filter that has a RRC filter response with a roll off $\alpha = 0,22$ and a bandwidth equal to the chip rate. The power is determined by calculating the RMS value of the signal samples at the measurement filter output taken at the decision points.
- (7) Average over TBD time slots.
- (8) Calculated the power control dynamic range difference between the maximum transmit output power measured in steps (3) and (4) and the minimum transmit output power measured in steps (6) and (7).
- (9) Configure the BS transmitter to enable power control steps of 2 dB and of 3 dB, respectively, and repeat steps (2) to (8).

6.4.3.5 Test requirements

The power control dynamic range derived according to 6.4.3.4.2 shall be in compliance with the requirements in 6.4.3.2.

6.4.4 Minimum transmit power

6.4.4.1 Definition and applicability

The minimum controlled output power of the BS is when the power control setting is set to a minimum value. This is when the power control indicates a minimum transmit output power is required.

The requirements in this subclause shall apply to base stations intended for general-purpose applications.

6.4.4.2 Conformance requirements

The DL minimum transmit power shall be lower than or equal to

Maximum output power – 30 dB.

The reference for this requirement is TS 25.105 subclause 6.4.4.1.

6.4.4.3 Test purpose

The test purpose is to verify the ability of the BS to reduce its output power to a specified value.

6.4.4.4 Method of test

6.4.4.4.1 Initial conditions

- (1) Connect the BS tester to the antenna connector of the BS under test.
- (2) Set the parameters of the BS transmitted signal according to table 6.4.4.4.1.1.
- (3) Set up a call between the BS under test and the BS tester according to the generic call setup procedure.

NOTE: The BS tester used for this test must have the ability

- to analyze the output signal of the BS under test with respect to thermal power;
- to simulate an UE with respect to the generation of TPC commands embedded in a valid UE signal.

Table 6.4.4.4.1.1: Parameters of the BS transmitted signal for minimum transmit power test

| Parameter | Value/description |
|----------------------------------|---|
| TDD Duty Cycle | TS i ; $i = 0, 1, 2, \dots, 14$: transmit, if i is even; receive, if i is odd. |
| Number of DPCH in each active TS | 9 |
| Power of each DPCH | 1/9 of Base Station output power |
| Data content of DPCH | real life (sufficient irregular) |

6.4.4.4.2 Procedure

- (1) Configure the BS transmitter to enable power control steps of size 1 dB.
- (2) Set the BS tester to produce a sequence of TPC commands related to all active DPCH, with content "Decrease Tx power". This sequence shall be sufficiently long so that the transmit output power of all active DPCH is controlled to reach its minimum, and shall be transmitted to the BS within the odd time slots TS i (receive time slots of the BS).
- (3) Measure the power of the BS output signal over the 2464 active chips of each even time slot TS i (this excludes the guard period), and with a measurement filter that has a RRC filter response with a roll off $\alpha = 0,22$ and a bandwidth equal to the chip rate. The power is determined by calculating the RMS value of the signal samples at the measurement filter output taken at the decision points.
- (4) Average over TBD time slots.
- (5) Configure the BS transmitter to enable power control steps of 2 dB and of 3 dB, respectively, and repeat steps (2) to (4).

6.4.4.5 Test requirements

For all measurements, the minimum transmit power derived in step (4) of 6.4.4.2 shall be at least 30 dB below the maximum output power as declared by the manufacturer; see 6.2.

6.4.5 Primary CCPCH power

6.4.5.1 Definition and applicability

Primary CCPCH power is the transmission power of the Primary Common Control Physical Channel averaged over the transmit timeslot. Primary CCPCH power is signaled on the BCH.

The requirements in this subclause shall apply to base stations intended for general-purpose applications.

6.4.5.2 Conformance requirements

In normal conditions, the Primary CCPCH power shall remain within ± 2 dB of the value indicated by the signaling message on the BCH.

In extreme conditions, the Primary CCPCH power shall remain within $\pm 2,5$ dB of the value indicated by the signaling message on the BCH.

The reference for this requirement is TS 25.105 subclause 6.4.5.

6.4.5.3 Test purpose

The power of the Primary CCPCH received by the UE, together with the information on the Primary CCPCH nominal transmit power signaled on the BCH, are used by the UE for path loss estimation and adjustment of its own transmit power. Therefore, deviations of the Primary CCPCH power from its nominal value are transposed by the UE into deviations from the wanted transmit power of the UE.

The test purpose is to verify that the Primary CCPCH power remains within its specified tolerances under normal and extreme conditions.

6.4.5.4 Method of test

6.4.5.4.1 Initial conditions

- (1) Connect the BS tester to the antenna connector of the BS under test. The BS tester must have the ability to analyze the output signal of the BS under test with respect to code domain power, by applying the global in-channel Tx test method described in Annex C.
- (2) Set the parameters of the BS transmitted signal according to table 6.4.5.4.1.1.
- (3) Set the environmental conditions to normal.

Table 6.4.5.4.1.1: Parameters of the BS transmitted signal for Primary CCPCH power testing

| Parameter | Value/description |
|--|---|
| TDD Duty Cycle | TS i ; $i = 0, 1, 2, \dots, 14$: transmit, if i is even; receive, if i is odd. |
| Time slots carrying PCCPCH | TS 0 and TS 8 |
| Number of additional DPCH in TS 0 and TS 8 | 3 |
| Base station output power | Maximum, according to manufacturer's declaration |
| Power of PCCPCH | $\frac{1}{4}$ of BS output power |
| Power of each DPCH in TS 0 and TS 8 | $\frac{1}{4}$ of BS output power |
| Data content of DPCH | Real life (sufficient irregular) |

6.4.5.4.2 Procedure

- (1) Measure the PCCPCH power in TS 0 and TS 8 by applying the global in-channel Tx test method described in Annex C.
- (2) Average over TBD time slots.
- (3) Set the environmental conditions to extreme and repeat steps (1) and (2).

6.4.5.5 Test requirements

The Primary CCPCH power, measured according to subclause 6.4.5.4.2, shall be within the limits defined in subclause 6.4.5.2.

6.5 Transmit OFF power

6.5.1 Definition and applicability

The transmit OFF power is the maximum residual output power within the channel bandwidth when the BS does not transmit.

6.5.2 Conformance requirements

The transmit OFF power shall be less than -33 dBm measured with a filter that has a Root-Raised Cosine (RRC) filter response with a roll-off $\alpha = 0,22$ and a bandwidth equal to the chip rate.

The reference for this requirement is TS 25.105 subclause 6.5.1.

6.5.3 Test purpose

This test verifies the ability of the BS to reduce its transmit OFF power to a value below the specified limit. This ability is needed to minimize the interference for other users receiving on the same frequency.

6.5.4 Method of test

6.5.4.1 Initial conditions

- (1) Connect the power measuring equipment to the BS antenna connector.
- (2) Set the parameters of the transmitted signal according to table 6.5.4.1.1.

Table 6.5.4.1.1 Parameters of the transmitted signal for transmit OFF power test

| Parameter | Value/description |
|----------------------------------|---|
| TDD Duty Cycle | TS i ; $i = 0, 1, 2, \dots, 14$: transmit, if i is even; receive, if i is odd. |
| Base Station output power | Maximum, according to manufacturer's declaration |
| Number of DPCH in each active TS | 9 |
| Power of each DPCH | 1/9 of Base Station output power |
| Data content of DPCH | Real life (sufficient irregular) |

6.5.4.2 Procedure

- (1) Measure the power of the BS output signal over the transmit off power period starting 20 chips before the start of the odd time slots TS i (receive time slots of the BS), and ending 16 chips before the next even time slot (transmit time slot of the BS) starts, and with a measurement filter that has a RRC filter response with a roll off $\alpha = 0,22$ and a bandwidth equal to the chip rate. The power is determined by calculating the RMS value of the signal samples at the measurement filter output taken at the decision points.
- (2) Average over TBD time slots.
- (3) Run steps (1) and (2) for RF channels Low / Mid / High.

6.5.5 Test requirements

The value of the transmit OFF power derived according to subclause 6.5.4.2, shall be below the limit defined in subclause 6.5.2.

6.6 Output RF spectrum emissions

6.6.1 Occupied bandwidth

6.6.1.1 Definition and applicability

Occupied bandwidth is a measure of the bandwidth containing 99% of the total integrated power for transmitted spectrum and is centered on the assigned channel frequency.

The requirements in this subclause shall apply to base stations intended for general-purpose applications.

6.6.1.2 Conformance requirements

The occupied bandwidth shall be less than 5 MHz based on a chip rate of 3,84 Mcps.

The reference for this requirement is TS 25.105 subclause 6.6.1.

6.6.1.3 Test purpose

The occupied bandwidth, defined in the Radio Regulations of the International Telecommunication Union ITU, is a useful concept for specifying the spectral properties of a given emission in the simplest possible manner; see also Recommendation ITU-R SM.328-9 [7]. The test purpose is to verify that the emission of the BS does not occupy an excessive bandwidth for the service to be provided and is, therefore, not likely to create interference to other users of the spectrum beyond undue limits.

6.6.1.4 Method of test

6.6.1.4.1 Initial conditions

- (1) Connect the measuring equipment to the antenna connector of the BS under test.
- (2) Set the parameters of the BS transmitted signal according to table 6.6.1.4.1.1.

Table 6.6.1.4.1.1: Parameters of the BS transmitted signal for occupied bandwidth testing

| Parameter | Value/description |
|----------------------------------|---|
| TDD Duty Cycle | TS i ; $i = 0, 1, 2, \dots, 14$: transmit, if i is even; receive, if i is odd. |
| Base Station output power | Maximum, according to manufacturer's declaration |
| Number of DPCH in each active TS | 9 |
| Power of each DPCH | 1/9 of Base Station output power |
| Data content of DPCH | Real life (sufficient irregular) |

6.6.1.4.2 Procedure

- (1) Measure the power of the transmitted signal with a measurement filter of bandwidth 30 kHz. The characteristic of the filter shall be approximately Gaussian (typical spectrum analyzer filter). The center frequency of the filter shall be stepped in contiguous 30 kHz steps from a minimum frequency, which shall be $(7,5 - 0,015)$ MHz below the assigned channel frequency of the transmitted signal, up to a maximum frequency, which shall be $(7,5 + 0,015)$ MHz above the assigned channel frequency of the transmitted signal. The time duration of each step shall be sufficiently long to capture one active time slot. The measured power shall be recorded for each step.
- (2) Determine the transmitted power within the assigned channel bandwidth by accumulating the recorded power measurements results of all steps with center frequencies from $(2,5 - 0,015)$ MHz below the assigned channel frequency up to $(2,5 + 0,015)$ MHz above the assigned channel frequency.
- (3) Determine the total transmitted power by accumulating the recorded power measurements results of all steps.
- (4) Calculate the ratio

transmitted power within the assigned channel bandwidth acc. to (2) / total transmitted power acc. to (3).

6.6.1.5 Test requirements

The ratio calculated in step (4) of subclause 6.6.1.4.2 shall be 0,99 or greater.

6.6.2 Out of band emission

Out of band emissions are unwanted emissions immediately outside the [channel] bandwidth resulting from the modulation process and non-linearity in the transmitter but excluding spurious emissions. This out of band emission limit can be specified in terms of a spectrum emission mask and adjacent channel power ratio for the transmitter.

6.6.2.1 Spectrum emission mask

< Editor's note: The emission mask of the base station is an item for further study. >

- 6.6.2.1.1 Test purpose
- 6.6.2.1.2 Test case
- 6.6.2.1.3 Conformance requirements

6.6.2.2 Adjacent Channel Leakage power Ratio (ACLR)

6.6.2.2.1 Definition and applicability

Adjacent Channel Leakage power Ratio (ACLR) is the ratio of the transmitted power to the power measured after a receive filter in the adjacent channel(s). Both the transmitted and the received power are measured through a matched filter (root raised cosine and roll-off 0,22) with a noise power bandwidth equal to the chip rate.

The requirements in this subclause shall apply to base stations intended for general-purpose applications.

6.6.2.2.2 Conformance requirements

The ACLR shall be equal to or greater than the limits given in Table 6.6.2.2.2.1.

Table 6.6.2.2.2.1: BS ACLR limits

| BS adjacent channel offset | ACLR limit |
|----------------------------|------------|
| ± 5 MHz | [45] dB |
| ± 10 MHz | [55] dB |

The reference for this requirement is TS 25.105 subclause 6.6.2.2.1.

6.6.2.2.3 Test purpose

The test purpose is to verify the ability of the BS to limit the interference produced by the transmitted signal to other UTRA receivers operating at the first or second adjacent RF channel.

6.6.2.2.4 Method of test

6.6.2.2.4.1 Initial conditions

- (1) Connect the measuring equipment to the antenna connector of the BS under test.
- (2) Set the parameters of the BS transmitted signal according to table 6.6.2.2.4.1.1.

Table 6.6.2.2.4.1.1: Parameters of the BS transmitted signal for ACLR testing

| Parameter | Value/description |
|----------------------------------|---|
| TDD Duty Cycle | TS i ; $i = 0, 1, 2, \dots, 14$: transmit, if i is even; receive, if i is odd. |
| Base Station output power | Maximum, according to Manufacturer's declaration |
| Number of DPCH in each active TS | 9 |
| Power of each DPCH | 1/9 of Base Station output power |
| Data content of DPCH | Real life (sufficient irregular) |

6.6.2.2.4.2 Procedure

- (1) Measure transmitted power over the 2464 active chips of the even time slots TS i (this excludes the guard period), and with a measurement filter that has a RRC filter response with a roll off $\alpha = 0,22$ and a bandwidth equal to the chip rate. The power is determined by calculating the RMS value of the signal samples at the measurement filter output taken at the decision points.
- (2) Average over TBD time slots.
- (3) Measure interference power at the first lower adjacent RF channel (center frequency 5 MHz below the assigned channel frequency of the transmitted signal) over the 2464 active chips of the even time slots TS i (-this excludes the guard period), and with a measurement filter that has a RRC filter response with a roll off $\alpha = 0,22$ and a bandwidth equal to the chip rate. The power is determined by calculating the RMS value of the signal samples at the measurement filter output taken at the decision points.
- (4) Average over TBD time slots.
- (5) Calculate the ACLR by the ratio

$$\text{ACLR} = \text{transmitted power acc. to (2)} / \text{interference power acc. to (4)}.$$
- (6) Repeat steps (3), (4) and (5) for the second lower adjacent RF channel (center frequency 10 MHz below the assigned channel frequency of the transmitted signal) and also for the first and second upper adjacent RF channel (center frequency 5 MHz and 10 MHz above the assigned channel frequency of the transmitted signal, respectively).

6.6.2.2.5 Test requirements

The ACLR calculated in step (5) of subclause 6.6.2.2.4.2 shall be equal or greater than the limits given in Table 6.6.2.2.2.1.

6.6.2.3 Protection outside a licensee's frequency block

6.6.2.3.1 Test purpose

This requirement is applicable if protection is required outside a licensee's defined frequency block.

6.6.2.3.2 Test case

This requirement applies for frequencies outside the licensee's frequency block, up to an offset of [12.5MHz] from a carrier frequency.

Compliance with this provision is based on the use of measurement instrumentation employing a resolution bandwidth of 1 MHz or greater. However, in the 1 MHz bands immediately outside and adjacent to the frequency block a resolution bandwidth of at least one percent of the fundamental emission of the transmitter may be employed. The emission bandwidth is defined as the width of the signal between two points, one below the carrier centre frequency and one above the carrier centre frequency, outside of which all emissions are attenuated at least 26dB below the transmitter power.

When measuring the emission limits, the nominal carrier frequency shall be adjusted as close to the licensee's frequency block edges, both upper and lower, as the design permits.

The measurements of emission power shall be mean power.

6.6.2.3.3 Conformance requirements

The power of any emission shall be attenuated below the transmit power (P) by at least $43 + 10 \log (P)$ dB.

6.6.3 Spurious emissions

6.6.3.1 Definition and applicability

Spurious emissions are emissions which are caused by unwanted transmitter effects such as harmonics emission, parasitic emission, intermodulation products and frequency conversion products, but exclude out of band emissions. This is measured at the base station RF output port.

The requirements in this subclause shall apply to base stations intended for general-purpose applications.

6.6.3.2 Conformance requirements

6.6.3.2.1 Mandatory requirements

The requirements of either subclause 6.6.3.2.1.1 or subclause 6.6.3.2.1.2 shall apply whatever the type of transmitter considered (single carrier or multi-carrier). It applies for all transmission modes foreseen by the manufacturer.

Either requirement applies at frequencies within the specified frequency ranges which are more than 12.5 MHz under the first carrier frequency used or more than 12.5 MHz above the last carrier frequency used.

6.6.3.2.1.1 Spurious emissions (Category A)

The following requirements shall be met in cases where Category A limits for spurious emissions, as defined in ITU-R Recommendation SM.329-7 [6], are applied.

The power of any spurious emission shall not exceed the maximum level given in Table 6.6.3.2.1.1.1.

Table 6.6.3.2.1.1.1: BS Mandatory spurious emissions limits, Category A

| Band | Maximum level | Measurement bandwidth | Note |
|-------------------|---------------|-----------------------|--|
| 9 kHz – 150 kHz | -13 dBm | 1 kHz | Bandwidth as in ITU SM.329-7, s4.1 |
| 150 kHz – 30 MHz | | 10 kHz | Bandwidth as in ITU SM.329-7, s4.1 |
| 30 MHz – 1 GHz | | 100 kHz | Bandwidth as in ITU SM.329-7, s4.1 |
| 1 GHz – 12,75 GHz | | 1 MHz | Upper frequency as in ITU SM.329-7, s2.6 |

The reference for this requirement is TS 25.105 subclause 6.6.3.1.1.1.

6.6.3.2.1.2 Spurious emissions (Category B)

The following requirements shall be met in cases where Category B limits for spurious emissions, as defined in ITU-R Recommendation SM.329-7 [6], are applied.

The power of any spurious emission shall not exceed the maximum levels given in Table 6.6.3.2.1.2.1.

Table 6.6.3.2.1.2.1: BS Mandatory spurious emissions limits, Category B

| Band | Maximum level | Measurement bandwidth | Note |
|-------------------|---------------|-----------------------|--|
| 9 kHz – 150 kHz | -36 dBm | 1 kHz | Bandwidth as in ITU SM.329-7, s4.1 |
| 150 kHz – 30 MHz | -36 dBm | 10 kHz | Bandwidth as in ITU SM.329-7, s4.1 |
| 30 MHz – 1 GHz | -36 dBm | 100 kHz | Bandwidth as in ITU SM.329-7, s4.1 |
| 1 GHz – 12,75 GHz | -30 dBm | 1 MHz | Upper frequency as in ITU SM.329-7, s2.6 |

The reference for this requirement is TS 25.105 subclause 6.6.3.1.2.1.

6.6.3.2.2 Co-existence with GSM

6.6.3.2.2.1 Operation in the same geographic area

This requirement may be applied for the protection of GSM 900 MS in geographic areas in which both GSM 900 and UTRA are deployed.

[This requirement assumes the scenario described in 25.942.] For different scenarios, the manufacturer may declare a different requirement.

The power of any spurious emission shall not exceed the maximum level given in Table 6.6.3.2.2.1.1.

Table 6.6.3.2.2.1.1: BS Spurious emissions limits for BS in geographic coverage area of GSM 900

| Band | Maximum level | Measurement bandwidth | Note |
|-------------------|---------------|-----------------------|------|
| 921 MHz – 960 MHz | -47 dBm | 100 kHz | |

The reference for this requirement is TS 25.105 subclause 6.6.3.2.1.1.

6.6.3.2.2.2 Co-located base stations

This requirement may be applied for the protection of GSM 900 BTS receivers when GSM 900 BTS and UTRA BS are co-located.

[This requirement assumes the scenario described in 25.942.] For different scenarios, the manufacturer may declare a different requirement.

The power of any spurious emission shall not exceed the maximum level given in Table 6.6.3.2.2.2.1.

Table 6.6.3.2.2.2.1: BS Spurious emissions limits for protection of the BS receiver

| Band | Maximum level | Measurement bandwidth | Note |
|-------------------|---------------|-----------------------|------|
| 876 MHz – 915 MHz | -98 dBm | 100 kHz | |

The reference for this requirement is TS 25.105 subclause 6.6.3.2.2.1.

6.6.3.2.3 Co-existence with DCS 1800

6.6.3.2.3.1 Operation in the same geographic area

This requirement may be applied for the protection of DCS 1800 MS in geographic areas in which both DCS 1800 and UTRA are deployed.

[This requirement assumes the scenario described in 25.942.] For different scenarios, the manufacturer may declare a different requirement.

The power of any spurious emission shall not exceed the maximum level given in Table 6.6.3.2.3.1.1.

Table 6.6.3.2.3.1.1: BS Spurious emissions limits for BS in geographic coverage area of DCS 1800

| Band | Maximum level | Measurement bandwidth | Note |
|---------------------|---------------|-----------------------|------|
| 1805 MHz – 1880 MHz | -57 dBm | 100 kHz | |

The reference for this requirement is TS 25.105 subclause 6.6.3.3.1.1.

6.6.3.2.3.2 Co-located base stations

This requirement may be applied for the protection of DCS 1800 BTS receivers when DCS 1800 BTS and UTRA BS are co-located.

[This requirement assumes the scenario described in 25.942.] For different scenarios, the manufacturer may declare a different requirement.

The power of any spurious emission shall not exceed the maximum level given in Table 6.6.3.2.3.2.1.

Table 6.6.3.2.3.2.1: BS Spurious emissions limits for BS co-located with DCS 1800 BTS

| Band | Maximum level | Measurement bandwidth | Note |
|---------------------|---------------|-----------------------|------|
| 1710 MHz – 1785 MHz | -98 dBm | 100 kHz | |

The reference for this requirement is TS 25.105 subclause 6.6.3.3.3.1.

6.6.3.3 Test purpose

The test purpose is to verify the ability of the BS to limit the interference caused by unwanted transmitter effects to other systems operating at frequencies which are more than 12,5 MHz away from of the UTRA band used.

6.6.3.4 Method of test

6.6.3.4.1 Initial conditions

- (1) Connect the measuring equipment to the antenna connector of the BS under test.
- (2) Set the parameters of the BS transmitted signal according to table 6.6.3.4.1.1.

Table 6.6.3.4.1.1: Parameters of the BS transmitted signal for spurious emissions testing

| Parameter | Value/description |
|----------------------------------|---|
| TDD Duty Cycle | TS i ; $i = 0, 1, 2, \dots, 14$: transmit, if i is even; receive, if i is odd. |
| Base Station output power | maximum, according to manufacturer's declaration |
| Number of DPCH in each active TS | 9 |
| Power of each DPCH | 1/9 of Base Station output power |
| Data content of DPCH | real life (sufficient irregular) |

6.6.3.4.2 Procedure

Measure the power of the spurious emissions by applying measurement filters with bandwidths as specified in the relevant tables of 6.6.3.2. The characteristic of the filters shall be approximately Gaussian (typical spectrum analyzer filters). The center frequency of the filter shall be stepped in contiguous steps over the frequency bands as given in the tables. The step width shall be equal to the respective measurement bandwidth. The time duration of each step shall be sufficiently long to capture one active time slot.

6.6.3.5 Test requirements

The spurious emissions measured according to subclause 6.6.3.4.2 shall not exceed the limits specified in the relevant tables of 6.6.3.2.

6.7 Transmit intermodulation

6.7.1 Definition and applicability

The transmit intermodulation performance is a measure of the capability of the transmitter to inhibit the generation of signals in its non linear elements caused by presence of the wanted signal and an interfering signal reaching the transmitter via the antenna.

The transmit intermodulation level is the power of the intermodulation products when a CDMA modulated interference signal is injected into the antenna connector at a level of 30 dB lower than that of the subject signal. The frequency of the interference signal shall be ± 5 MHz, ± 10 MHz and ± 15 MHz offset from the subject signal.

The requirements in this subclause shall apply to base stations intended for general-purpose applications.

6.7.2 Conformance requirements

The transmit intermodulation level shall not exceed the out of band or the spurious emission requirements of subclause 6.6.2 and 6.6.3, respectively.

The reference for this requirement is TS 25.105 subclause 6.7.1.

6.7.3 Test purpose

The test purpose is to verify the ability of the BS transmitter to restrict the generation of intermodulation products in its non linear elements caused by presence of the wanted signal and an interfering signal reaching the transmitter via the antenna to below specified levels.

6.7.4 Method of test

6.7.4.1 Initial conditions

(1) Connect the measuring equipment, the BS under test and the CDMA signal generator as shown in figure 6.7.4.1.1.

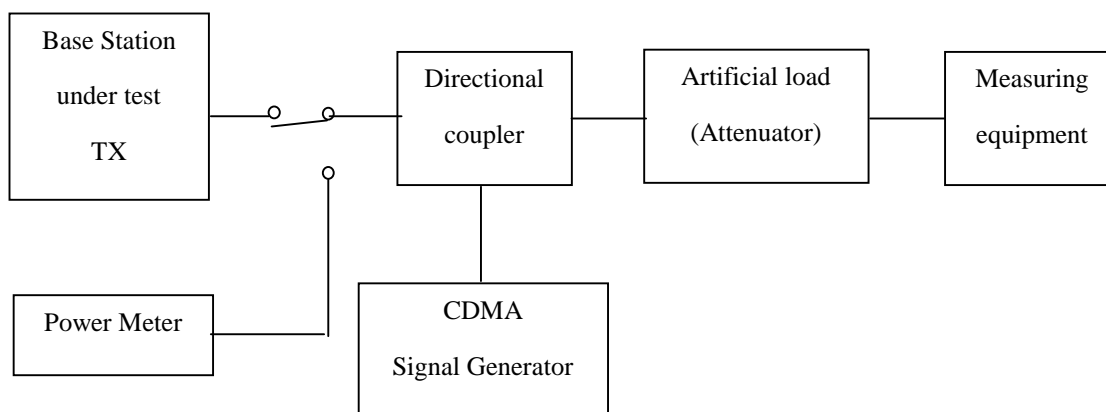

Figure 6.7.4.1.1: Measuring setup for Base Station transmit intermodulation testing

(2) Set the parameters of the BS transmitted signal according to table 6.7.4.1.1.

Table 6.7.4.1.1: Parameters of the BS transmitted signal for transmit intermodulation testing

| Parameter | Value/description |
|----------------------------------|---|
| TDD Duty Cycle | TS i ; $i = 0, 1, 2, \dots, 14$: transmit, if i is odd; receive, if i is even. |
| Base Station output power | maximum, according to manufacturer's declaration |
| Number of DPCH in each active TS | 9 |
| Power of each DPCH | 1/9 of Base Station output power |
| Data content of DPCH | real life (sufficient irregular) |

(3) Configure the CDMA signal generator to produce an interference signal with a level of 30 dB lower than that of the BS transmitted signal. The interference signal shall be like-modulated as the BS transmitted signal, and the active time slots of both signals shall be synchronized. The frequency of the interference signal shall be ± 5 MHz, ± 10 MHz and ± 15 MHz offset from the BS transmitted signal.

6.7.4.2 Procedure

Apply the test procedures for out of band and spurious emissions as described in 6.6.2 and 6.6.3, respectively. The frequency band occupied by the interference signal are excluded from the measurements.

6.7.5 Test requirements

The conformance requirements for out of band and spurious emissions as specified in 6.6.2 and 6.6.3 shall be met.

6.8 Transmit Modulation

6.8.1 Modulation accuracy

6.8.1.1 Definition and applicability

The modulation accuracy is a measure of the difference between the measured waveform and the theoretical modulated waveform (the error vector). A quantitative measure of the modulation accuracy is the error vector magnitude (EVM) which is defined as the square root of the ratio of the mean error vector power to the mean reference signal power expressed as %. The measurement interval is one timeslot.

The requirements in this subclause shall apply to base stations intended for general-purpose applications.

NOTE: The theoretical modulated waveform shall be calculated on the basis that the transmit pulse shaping filter is a root-raised cosine (RRC) with roll-off $\alpha = 0,22$ in the frequency domain. The impulse response of the chip impulse filter $RC_0(t)$ is

$$RC_0(t) = \frac{\sin\left(\pi \frac{t}{T_c} (1-\alpha)\right) + 4\alpha \frac{t}{T_c} \cos\left(\pi \frac{t}{T_c} (1+\alpha)\right)}{\pi \frac{t}{T_c} \left(1 - \left(4\alpha \frac{t}{T_c}\right)^2\right)}$$

Where the roll-off factor $\alpha = 0,22$ and the chip duration $T_c = \frac{1}{\text{chiprate}} \approx 0.26042 \mu\text{s}$.

6.8.1.2 Conformance requirements

The error vector magnitude (EVM) shall not exceed 12,5 %.

The reference for this requirement is TS 25.105 subclause 6.8.2.1.

6.8.1.3 Test purpose

The test purpose is to verify the ability of the BS transmitter to generate a sufficient precise waveform and thus to enable the UE receiver to achieve the specified error performance.

6.8.1.4 Method of test

6.8.1.4.1 Initial conditions

(1) Connect the measuring equipment to the antenna connector of the BS under test.

(2) Set the parameters of the BS transmitted signal according to table 6.8.1.4.1.1.

Table 6.8.1.4.1.1: Parameters of the BS transmitted signal for modulation accuracy testing

| Parameter | Value/description |
|----------------------------------|---|
| TDD Duty Cycle | TS i ; $i = 0, 1, 2, \dots, 14$: transmit, if i is even; receive, if i is odd. |
| Number of DPCH in each active TS | 1 |
| Base station power | maximum, according to manufacturer's declaration |
| Data content of DPCH | real life (sufficient irregular) |

6.8.1.4.2 Procedure

Measure the error vector magnitude (EVM) by applying the global in-channel Tx test method described in Annex C.

6.8.1.5 Test requirements

The error vector magnitude (EVM) measured according to subclause 6.8.1.4.2 shall not exceed 12,5 %.

6.8.2 Peak code domain error

6.8.2.1 Definition and applicability

The code domain error is computed by projecting the error vector power onto the code domain at the maximum spreading factor. The error power for each code is defined as the ratio to the mean power of the reference waveform expressed in dB. And the Peak Code Domain Error is defined as the maximum value for Code Domain Error. The measurement interval is one timeslot.

The requirements in this subclause shall apply to base stations intended for general-purpose applications.

6.8.2.2 Conformance requirements

The peak code domain error shall not exceed -28 dB.

The reference for this requirement is TS 25.105 subclause 6.8.3.1.

6.8.2.3 Test purpose

The test purpose is to verify the ability of the BS transmitter to limit crosstalk among codes and thus to enable the UE receiver to achieve the specified error performance.

6.8.2.4 Method of test

6.8.2.4.1 Initial conditions

- (1) Connect the measuring equipment to the antenna connector of the BS under test.
- (2) Set the parameters of the BS transmitted signal according to table 6.8.2.4.1.1.

Table 6.8.2.4.1.1: Parameters of the BS transmitted signal

| Parameter | Value/description |
|----------------------------------|---|
| TDD Duty Cycle | TS i ; $i = 0, 1, 2, \dots, 14$: transmit, if i is even; receive, if i is odd. |
| Base Station output power | maximum, according to manufacturer's declaration |
| Number of DPCH in each active TS | 9 |
| Power of each DPCH | 1/9 of Base Station output power |
| Data content of DPCH | real life (sufficient irregular) |
| Spreading factor | 16 |

6.8.2.4.2 Procedure

Measure the peak code domain error by applying the global in-channel Tx test method described in Annex C.

6.8.2.5 Test requirements

The peak code domain error measured according to subclause 6.8.2.4.2 shall not exceed -28 dB.

7 Receiver characteristics

7.1 General

All tests unless otherwise stated in this subclause shall be conducted on Base Station Systems fitted with a full complement of Transceivers for the configuration. The manufacturer shall provide appropriate logical or physical test access to perform all tests in this subclause. Measurements shall include any RX multicoupler.

The tests in clause 7 assume that the receiver is not equipped with diversity. For receivers with diversity, the tests may be performed by applying the specified signals to one of the receiver inputs, and terminating or disabling the other(s). The tests and requirements are otherwise unchanged.

For receivers with diversity, testing of conformance shall be performed by applying the specified signals to one of the receiver inputs, and terminating or disabling the other(s).

In all the relevant subclauses in this clause all Bit Error Ratio (BER), Residual BER (RBER) and Frame Erasure Ratio (FER) measurements shall be carried out according to the general rules for statistical testing.

Unless detailed the receiver characteristic are specified at each antenna connector of the BS.

7.2 Reference sensitivity level

7.2.1 Definition and applicability

The reference sensitivity is the minimum receiver input power measured at the antenna connector at which the BER does not exceed the specific value.

The requirements in this subclause shall apply to base stations intended for general-purpose applications.

7.2.2 Conformance requirements

For the measurement channel specified in Annex A.2.1, the reference sensitivity level and performance of the BS shall be as specified in table 7.2.2.1 below.

Table 7.2.2.1: BS reference sensitivity levels

| Data rate | BS reference sensitivity level (dBm) | BER |
|-----------|--------------------------------------|----------------------------|
| 12,2 kbps | -110 dBm | BER shall not exceed 0,001 |

The reference for this requirement is TS 25.105 subclause 7.2.1.

7.2.3 Test purpose

The test purpose is to verify the ability of the BS to receive a prescribed single-code test signal of minimum input power under defined conditions (no interference, no multipath propagation) with a BER not exceeding a specified limit. This test is also used as a reference case for other tests to allow the assessment of degradations due to various sources of interference.

7.2.4 Method of test

7.2.4.1 Initial conditions

- (1) Connect the BS tester (UE simulator) to the antenna connector of one BS Rx port.
- (2) Terminate any other BS Rx port not under test.

- (3) Set up a call between the BS tester and the BS. The characteristics of the call shall be according to the 12,2 kbit/s UL reference measurement channel specified in Annex A.2.1.
- (4) The level of BS tester output signal measured at the BS antenna connector shall be adjusted to -110 dBm.

7.2.4.2 Procedure

- (1) Measure the BER by comparing the bit sequence of the information data transmitted by the BS tester with the bit sequence obtained from the BS receiver.
- (2) Interchange the connections of the BS Rx ports and repeat the measurement according to (1).

7.2.5 Test requirements

For any BS Rx port tested, the measured BER shall not exceed 0,001.

7.3 Dynamic range

7.3.1 Definition and applicability

The receiver dynamic range is the input power range at each BS antenna connector over which the BER does not exceed a specified value.

The requirements in this subclause shall apply to base stations intended for general-purpose applications.

7.3.2 Conformance requirements

The static BER reference performance as specified in subclause 7.2 shall be met over a receiver input range of 30 dB above the specified reference sensitivity level for the 12,2 kbit/s channel.

The reference for this requirement is TS 25.105 subclause 7.3.

7.3.3 Test purpose

The test purpose is to verify the ability of the BS to receive a prescribed single-code test signal of maximum input power under defined conditions (no interference, no multipath) with a BER not exceeding a specified limit.

7.3.4 Method of test

7.3.4.1 Initial conditions

- (1) Connect the BS tester (UE simulator) to the antenna connector of one BS Rx port.
- (2) Terminate any other BS Rx port not under test.
- (3) Set up a call between the BS tester and the BS. The characteristics of the call shall be according to the 12,2 kbit/s UL reference measurement channel specified in Annex A.2.1.
- (4) The level of the BS tester output signal measured at the BS antenna connector shall be adjusted to $(-110 + 30)$ dBm.

7.3.4.2 Procedure

- (1) Measure the BER by comparing the bit sequence of the information data transmitted by the BS tester with the bit sequence obtained from the BS receiver.
- (2) Interchange the connections of the BS Rx ports and repeat the measurement according to (1)

7.3.5 Test requirements

For any BS Rx port tested, the measured BER shall not exceed 0,001.

7.4 Adjacent Channel Selectivity (ACS)

7.4.1 Definition and applicability

Adjacent channel selectivity (ACS) is a measure of the receiver ability to receive a wanted signal at its assigned channel frequency in the presence of an adjacent channel signal at a given frequency offset from the center frequency of the assigned channel.

The requirements in this subclause shall apply to base stations intended for general-purpose applications.

7.4.2 Conformance requirements

The BER, measured on the wanted signal in the presence of an interfering signal, shall not exceed 0,001 for the parameters specified in table 7.4.2.2.1.

Table 7.4.2.2.1: Parameters of the wanted signal and the interfering signal for ACS testing

| Parameter | Level | Unit |
|---|-------|--------|
| Data rate | 12,2 | kbit/s |
| Wanted signal | [] | dBm |
| Interfering signal | [] | dBm |
| F _w (modulated) | 5 | MHz |
| NOTE: F _w is the frequency offset of the unwanted interfering signal from the assigned channel frequency of the wanted signal. | | |

The reference for this requirement is TS 25.105 subclause 7.4.1.

7.4.3 Test purpose

The test purpose is to verify the ability of the BS receiver filter to sufficiently suppress interfering signals in the channels adjacent to the wanted channel.

7.4.4 Method of test

7.4.4.1 Initial conditions

- (1) Connect an UE simulator operating at the assigned channel frequency of the wanted signal and a signal generator used to produce the interfering signal in the adjacent channel to the antenna connector of one Rx port.
- (2) Terminate any other Rx port not under test.
- (3) Set up a call between the UE simulator and the BS tester. The characteristics of the call shall be set according to the UL reference measurement channel (12,2 kbit/s) specified in Annex A.2.1. The level of the UE simulator signal measured at the BS antenna connector shall be adjusted to the value specified in table 7.4.2.2.1.
- (4) Set the signal generator to produce an interfering signal that is equivalent to a continuous wideband CDMA signal with one code of chip frequency 3,84 Mchip/s, filtered by an RRC transmit pulse-shaping filter with roll-off $\alpha = 0,22$. The level of the interfering signal measured at the BS antenna connector shall be adjusted to the value specified in table 7.4.2.2.1.

7.4.4.2 Procedure

- (1) Set the center frequency of the interfering signal to 5 MHz above the assigned channel frequency of the wanted signal.
- (2) Measure the BER of the wanted signal at the BS receiver.
- (3) Set the center frequency of the interfering signal to 5 MHz below the assigned channel frequency of the wanted signal.
- (4) Measure the BER of the wanted signal at the BS receiver.
- (5) Interchange the connections of the BS Rx ports and repeat the measurements according to steps (1) to (4).

7.4.5 Test requirements

The BER measured according subclause 7.4.4.2 to shall not exceed 0,001.

7.5 Blocking characteristics

7.5.1 Definition and applicability

The blocking characteristics is a measure of the receiver ability to receive a wanted signal at its assigned channel frequency in the presence of an unwanted interferer on frequencies other than those of the adjacent channels. The blocking performance shall apply at all frequencies as specified in table 7.5.2.1, using a 1 MHz step size.

The requirements in this subclause shall apply to base stations intended for general-purpose applications.

7.5.2 Conformance requirements

The static reference performance as specified in clause 7.2 should be met with a wanted and an interfering signal coupled to the BS antenna input using the parameters specified in table 7.5.2.1.

Table 7.5.2.1: Blocking requirements

| Center frequency of interfering signal | Interfering signal level | Wanted signal level | Minimum offset of interfering signal | Type of interfering signal |
|---|--------------------------|---------------------|--------------------------------------|----------------------------|
| 1900 – 1920 MHz, 2010 – 2025 MHz | -40 dBm | <REFSENS> + 6 dB | 10 MHz | WCDMA signal with one code |
| 1880 – 1900 MHz, 1990 – 2010 MHz, 2025 – 2045 MHz | -40 dBm | <REFSENS> + 6 dB | 10 MHz | WCDMA signal with one code |
| 1920 – 1980 MHz | -40 dBm | <REFSENS> + 6 dB | 10 MHz | WCDMA signal with one code |
| 1 - 1880 MHz, 1980 – 1990 MHz, 2045 – 12750 MHz | -15 dBm | <REFSENS> + 6 dB | — | CW carrier |

The reference for this requirement is TS 25.105 subclause 7.5.

7.5.3 Test purpose

The test stresses the ability of the BS receiver to withstand high-level interference from unwanted signals at frequency offsets of 10 MHz or more, without undue degradation of its sensitivity.

7.5.4 Method of test

7.5.4.1 Initial conditions

- (1) Connect an UE simulator operating at the assigned channel frequency of the wanted signal and a signal generator to the antenna connector of one Rx port.
- (2) Terminate any other Rx port not under test.
- (3) Set up a call between the UE simulator and the BS tester. The characteristics of the call shall be set according to the UL reference measurement channel (12,2 kbit/s) specified in Annex A.2.1. The level of the UE simulator signal measured at the BS antenna connector shall be set to 6 dB above the reference sensitivity level specified in subclause 7.2.2.

7.5.4.2 Procedure

- (1) Set the signal generator to produce an interfering signal at a frequency offset F_{uw} from the assigned channel frequency of the wanted signal which is given by

$$F_{uw} = \pm (n \times 1 \text{ MHz}),$$

where n shall be increased in integer steps from $n = 10$ up to such a value that the center frequency of the interfering signal covers the range from 1 MHz to 12,75 GHz. The interfering signal level measured at the antenna connector shall be set in dependency of its center frequency, as specified in table 7.5.2.1. The type of the interfering signal is either equivalent to a continuous wideband CDMA signal with one code of chip frequency 3,84 Mchip/s, filtered by an RRC transmit pulse-shaping filter with roll-off $\alpha = 0,22$, or a CW signal; see table 7.5.2.1.

- (2) Measure the BER of the wanted signal at the BS receiver.
- (3) Interchange the connections of the BS Rx ports and repeat the measurements according to steps (1) and (2).

NOTE: The test procedure as defined in steps (1) and (2) requests to carry out more than 10000 BER measurements. To reduce the time needed for these measurements, it may be appropriate to conduct the test in two phases: During phase 1, BER measurements are made on all center frequencies of the interfering signal as requested but with a reduced confidence level, with the aim to identify those frequencies which require more detailed investigation. In phase 2, detailed measurements are made only at those critical frequencies identified before, applying the required confidence level.

7.5.5 Test requirements

In all measurements made according to subclause 7.5.4.2, the BER shall not exceed 0,001.

7.6 Intermodulation characteristics

7.6.1 Definition and applicability

Third and higher order mixing of two interfering RF signals can produce an interfering signal in the band of the desired channel. Intermodulation response rejection is a measure of the capability of the receiver to receive a wanted signal on its assigned channel frequency in the presence of two or more interfering signals which have a specific frequency relationship to the wanted signal.

The requirements in this subclause shall apply to base stations intended for general-purpose applications.

7.6.2 Conformance requirements

The static reference performance as specified in clause 7.2 should be met when the following signals are coupled to the BS antenna input.

- A wanted signal at the assigned channel frequency, 6 dB above the static reference level.
- Two interfering signals with the parameters specified in table 7.6.2.1.

Table 7.6.2.1: Parameters of the interfering signals for intermodulation characteristics testing

| Interfering Signal Level | Offset | Type of Interfering Signal |
|--------------------------|--------|----------------------------|
| - 48 dBm | 10 MHz | CW signal |
| - 48 dBm | 20 MHz | WCDMA signal with one code |

The reference for this requirement is TS 25.105 subclause 7.6.

7.6.3 Test purpose

The test purpose is to verify the ability of the BS receiver to inhibit the generation of intermodulation products in its non-linear elements caused by the presence of two high-level interfering signals at frequencies with a specific relationship to the frequency of the wanted signal.

7.6.4 Method of test

7.6.4.1 Initial conditions

- (1) Connect an UE simulator operating at the assigned channel frequency of the wanted signal and two signal generators to the antenna connector of one Rx port.
- (2) Terminate any other Rx port not under test.
- (3) Set up a call between the UE simulator and the BS tester. The characteristics of the call shall be set according to the UL reference measurement channel (12,2 kbit/s) specified in Annex A.2.1. The level of the UE simulator signal measured at the BS antenna connector shall be set to 6 dB above the reference sensitivity level specified in subclause 7.2.2.
- (4) Set the first signal generator to produce a CW signal with a level measured at the BS antenna connector of - 48 dBm.
- (5) Set the second signal generator to produce an interfering signal equivalent to a wideband CDMA signal with one code of chip frequency 3,84 Mchip/s, filtered by an RRC transmit pulse-shaping filter with roll-off $\alpha = 0,22$. The level of the signal measured at the BS antenna connector shall be set to - 48 dBm.

7.6.4.2 Procedure

- (1) The frequency of the first and the second signal generator shall be set to 10 MHz and 20 MHz, respectively, above the assigned channel frequency of the wanted signal.
- (2) Measure the BER of the wanted signal at the BS receiver.
- (3) The frequency of the first and the second signal generator shall be set to 10 MHz and 20 MHz, respectively, below the assigned channel frequency of the wanted signal.
- (4) Measure the BER of the wanted signal at the BS receiver.
- (5) Interchange the connections of the BS Rx ports and repeat the measurements according to steps (1) to (4).

7.6.5 Test requirements

The BER measured according subclause 7.6.4.2 to shall not exceed 0,001.

7.7 Spurious emissions

7.7.1 Definition and applicability

The spurious emissions power is the power of emissions generated or amplified in a receiver that appear at the BS antenna connector.

The requirements in this subclause shall apply to base stations intended for general-purpose applications.

For base stations equipped with only a single antenna connector for both transmitter and receiver, the requirements of subclause 6.6.3 shall apply to this port, and this test need not be performed.

7.7.2 Conformance requirements

The spurious emission shall be:

- (a) Less than -78 dBm/3.84 MHz at the BS antenna connector, for frequencies within the UTRA/TDD band and the UTRA/FDD BS receive band.
- (b) Less than -57 dBm/100 kHz at the BS antenna connector, for frequencies bands from 9 kHz to 1 GHz.
- (c) Less than -47 dBm/100 kHz at the BS antenna connector, for frequencies bands from 1 GHz to 12,75 GHz.

The reference for this requirement is TS 25.105 subclause 7.7.1.

7.7.3 Test purpose

The test purpose is to verify the ability of the BS to limit the interference caused by receiver spurious emissions to other systems.

7.7.4 Method of test

7.7.4.1 Initial conditions

- (1) Connect the measuring equipment to the antenna connector of one BS Rx port.
- (2) Terminate any other BS Rx port not under test.
- (3) Set the BS receiver to operational mode.

7.7.4.2 Procedure

- (1) Measure the power of the spurious emissions by applying the measuring equipment with the settings as specified in table 7.7.4.2.1. The characteristics of the measurement filter with the bandwidth 3,84 MHz shall be RRC with roll-off $\alpha = 0,22$. The characteristics of the measurement filter with the bandwidth 100 kHz shall be approximately Gaussian (typical spectrum analyzer filter). The center frequency of the filters shall be stepped in contiguous steps over the frequency bands as specified in table 7.7.4.2.1. The time duration of each step shall be sufficiently long to capture one radio frame.
- (2) Interchange the connections of the BS Rx ports and repeat the measurement according to (1).

Table 7.7.4.2.1: Measurement equipment settings

| Stepped frequency range | Measurement bandwidth | Step width | Detection mode |
|---|-----------------------|------------|----------------|
| UTRA TDD band UTRA FDD BS receive band | 3,84 MHz | 200 kHz | true RMS |
| 9 kHz – 1 GHz | 100 kHz | 100 kHz | |
| 1 GHz – 12,75 GHz | 100 kHz | 100 kHz | |

7.7.5 Test requirements

The spurious emissions measured according to subclause 7.7.4.2 shall not exceed the limits specified in subclause 7.7.2.

8 Performance requirements

8.1 General

Performance requirements for the BS are specified for the measurement channels defined in Annex A and the propagation conditions in Annex B. The requirements only apply to those measurement channels that are supported by the base station.

The requirements only apply to a base station with dual receiver antenna diversity. The required \hat{I}_{or}/I_{oc} shall be applied separately at each antenna port.

Table 8.1.1: Summary of Base Station performance targets

| Physical channel | Measurement channel | Static | Multi-path Case 1 | Multi-path Case 2 | Multi-path Case 3 |
|------------------|---------------------|---------------------------|---------------------------|---------------------------|------------------------------------|
| | | Performance metric | | | |
| DCH | 12,2 kbps | BLER < 10^{-2} | BLER < 10^{-2} | BLER < 10^{-2} | BLER < 10^{-2} |
| | 64 kbps | BLER < $10^{-1}, 10^{-2}$ | BLER < $10^{-1}, 10^{-2}$ | BLER < $10^{-1}, 10^{-2}$ | BLER < $10^{-1}, 10^{-2}, 10^{-3}$ |
| | 144 kbps | BLER < $10^{-1}, 10^{-2}$ | BLER < $10^{-1}, 10^{-2}$ | BLER < $10^{-1}, 10^{-2}$ | BLER < $10^{-1}, 10^{-2}, 10^{-3}$ |
| | 384 kbps | BLER < $10^{-1}, 10^{-2}$ | BLER < $10^{-1}, 10^{-2}$ | BLER < $10^{-1}, 10^{-2}$ | BLER < $10^{-1}, 10^{-2}, 10^{-3}$ |
| RACH | | | | | |

8.2 Demodulation in static propagation conditions

8.2.1 Demodulation of DCH

8.2.1.1 Definition and applicability

The performance requirement of DCH in static propagation conditions is determined by the maximum Block Error Ratio (BLER) allowed when the receiver input signal is at a specified \hat{I}_{or}/I_{oc} limit. The BLER is calculated for each of the measurement channels supported by the base station.

The requirements in this subclause shall apply to base stations intended for general-purpose applications.

8.2.1.2 Conformance requirements

For the parameters specified in table 8.2.1.2.1, the BLER should not exceed the piece-wise linear BLER curve specified in table 8.2.1.2.2.

Table 8.21.2.1: Parameters in static propagation conditions

| Parameters | Unit | Test 1 | Test 2 | Test 3 | Test 4 |
|-------------------------------|--------------|--------|--------|--------|--------|
| Number of DPCH _o | | 6 | 4 | 0 | 0 |
| $\frac{DPCH_o - E_c}{I_{or}}$ | dB | -9 | -9,5 | 0 | 0 |
| I | dBm/3,84 MHz | -60 | | | |
| Information Data Rate | kbps | 12,2 | 64 | 144 | 384 |

Table 8.2.1.2.2: Performance requirements in AWGN channel.

| Test Number | $\frac{\hat{I}_{or}}{I_{oc}}$ [dB] | BLER |
|-------------|------------------------------------|-----------|
| 1 | -1,9 | 10^{-2} |
| 2 | -0,3 | 10^{-1} |
| | 0,0 | 10^{-2} |
| 3 | 0,0 | 10^{-1} |
| | 0,2 | 10^{-2} |
| 4 | -0,5 | 10^{-1} |
| | -0,3 | 10^{-2} |

The reference for this requirement is TS 25.105 subclause 8.2.1.

8.2.1.3 Test purpose

The test purpose is to verify the ability of the BS to receive a prescribed test signal under defined conditions with a BLER not exceeding a specified limit.

8.2.1.4 Method of test

8.2.1.4.1 Initial conditions

8.2.1.4.2 Procedure

8.2.1.5 Test requirements

8.3 Demodulation of DCH in multipath fading conditions

8.3.1 Multipath fading Case 1

8.3.1.1 Definition and applicability

The performance requirement of DCH in multipath fading Case 1 is determined by the maximum Block Error Ratio (BLER) allowed when the receiver input signal is at a specified \hat{I}_{or}/I_{oc} limit. The BLER is calculated for each of the measurement channels supported by the base station.

The requirements in this subclause shall apply to base stations intended for general-purpose applications.

8.3.1.2 Conformance requirements

For the parameters specified in table 8.3.1.2.1, the BLER should not exceed the piece-wise linear BLER curve specified in table 8.3.1.2.2.

Table 8.3.1.2.1: Parameters in multipath Case 1 channel

| Parameters | Unit | Test 1 | Test 2 | Test 3 | Test 4 |
|-------------------------------|--------------|--------|--------|--------|--------|
| Number of DPCH _o | | 6 | 4 | 0 | 0 |
| $\frac{DPCH_o - E_c}{I_{or}}$ | DB | -9 | -9,5 | 0 | 0 |
| I | dBm/3,84 MHz | -60 | | | |
| Information Data Rate | kbps | 12,2 | 64 | 144 | 384 |

Table 8.3.1.2.2: Performance requirements in multipath Case 1 channel.

| Test Number | $\frac{\hat{I}_{or}}{I_{oc}}$ [dB] | BLER |
|-------------|------------------------------------|-----------|
| 1 | 6,3 | 10^{-2} |
| 2 | 5,5 | 10^{-1} |
| | 9,4 | 10^{-2} |
| 3 | 5,6 | 10^{-1} |
| | 9,4 | 10^{-2} |
| 4 | 5,5 | 10^{-1} |
| | 8,7 | 10^{-2} |

The reference for this requirement is TS 25.105 subclause 8.3.1.

8.3.1.3 Test purpose

The test purpose is to verify the ability of the BS to receive a prescribed test signal under defined conditions with a BLER not exceeding a specified limit.

8.3.1.4 Method of test

8.3.1.4.1 Initial conditions

8.3.1.4.2 Procedure

8.3.1.5 Test requirements

8.3.2 Multipath fading Case 2

8.3.2.1 Definition and applicability

The performance requirement of DCH in multipath fading Case 2 is determined by the maximum Block Error Ratio (BLER) allowed when the receiver input signal is at a specified \hat{I}_{or}/I_{oc} limit. The BLER is calculated for each of the measurement channels supported by the base station.

The requirements in this subclause shall apply to base stations intended for general-purpose applications.

8.3.2.2 Conformance requirements

For the parameters specified in table 8.3.2.2.1, the BLER should not exceed the piece-wise linear BLER curve specified in table 8.3.2.2.2.

Table 8.3.2.2.1: Parameters in multipath Case 2 channel

| Parameters | Unit | Test 1 | Test 2 | Test 3 | Test 4 |
|-------------------------------|--------------|--------|--------|--------|--------|
| Number of DPCH _o | | 2 | 0 | 0 | 0 |
| $\frac{DPCH_o - E_c}{I_{or}}$ | dB | -6 | 0 | 0 | 0 |
| I | DBm/3,84 MHz | -60 | | | |
| Information Data Rate | kbps | 12,2 | 64 | 144 | 384 |

Table 8.3.2.2.2: Performance requirements in multipath Case 2 channel.

| Test Number | $\frac{\hat{I}_{or}}{I_{oc}}$ [dB] | BLER |
|-------------|------------------------------------|-----------|
| 1 | 0,1 | 10^{-2} |
| 2 | 0,4 | 10^{-1} |
| | 2,8 | 10^{-2} |
| 3 | 3,6 | 10^{-1} |
| | 6,0 | 10^{-2} |
| 4 | 3,0 | 10^{-1} |
| | 5,4 | 10^{-2} |

The reference for this requirement is TS 25.105 subclause 8.3.2.

8.3.2.3 Test purpose

The test purpose is to verify the ability of the BS to receive a prescribed test signal under defined conditions with a BLER not exceeding a specified limit.

8.3.2.4 Method of test

8.3.2.4.1 Initial conditions

8.3.2.4.2 Procedure

8.3.2.5 Test requirements

8.3.3 Multipath fading Case 3

8.3.3.1 Definition and applicability

The performance requirement of DCH in multipath fading Case 3 is determined by the maximum Block Error Ratio (BLER) allowed when the receiver input signal is at a specified \hat{I}_{or}/I_{oc} limit. The BLER is calculated for each of the measurement channels supported by the base station.

The requirements in this subclause shall apply to base stations intended for general-purpose applications.

8.3.3.2 Conformance requirements

For the parameters specified in table 8.3.3.2.1, the BLER should not exceed the piece-wise linear BLER curve specified in Table 8.3.3.2.2.

Table 8.3.3.2.1: Parameters in multipath Case 3 channel

| Parameters | Unit | Test 1 | Test 2 | Test 3 | Test 4 |
|-------------------------------|--------------|--------|--------|--------|--------|
| Number of DPCH _o | | 2 | 0 | 0 | 0 |
| $\frac{DPCH_o - E_c}{I_{or}}$ | dB | -6 | 0 | 0 | 0 |
| I | dBm/3,84 MHz | -60 | | | |
| Information Data Rate | kbps | 12,2 | 64 | 144 | 384 |

Table 8.8: Performance requirements in multipath Case 3 channel.

| Test Number | $\frac{\hat{I}_{or}}{I_{oc}}$ [dB] | BLER |
|-------------|------------------------------------|-----------|
| 1 | -0,6 | 10^{-2} |
| 2 | 0,7 | 10^{-1} |
| | 2,4 | 10^{-2} |
| | 3,8 | 10^{-3} |
| 3 | 3,9 | 10^{-1} |
| | 5,9 | 10^{-2} |
| | 7,3 | 10^{-3} |
| 4 | 2,8 | 10^{-1} |
| | 4,2 | 10^{-2} |
| | 4,8 | 10^{-3} |

The reference for this requirement is TS 25.105 subclause 8.3.3.

8.3.3.3 Test purpose

The test purpose is to verify the ability of the BS to receive a prescribed test signal under defined conditions with a BLER not exceeding a specified limit.

8.3.3.4 Method of test

8.3.3.4.1 Initial conditions

8.3.3.4.2 Procedure

8.3.3.5 Test requirements

Annex A (normative): Measurement Channels

A.1 General

A.2 Reference measurement channel

A.2.1 UL reference measurement channel (12.2 kbps)

| Parameter | |
|--|-------------|
| Information data rate | 12.2 kbps |
| RU's allocated | 2 RU |
| Midamble | 512 chips |
| Interleaving | 20 ms |
| Power control | 2 Bit/user |
| TFCI | 16 Bit/user |
| Inband signalling DCCH | 2 kbps |
| Puncturing level at Code rate 1/3 : DCH / DCCH | 5% / 0% |

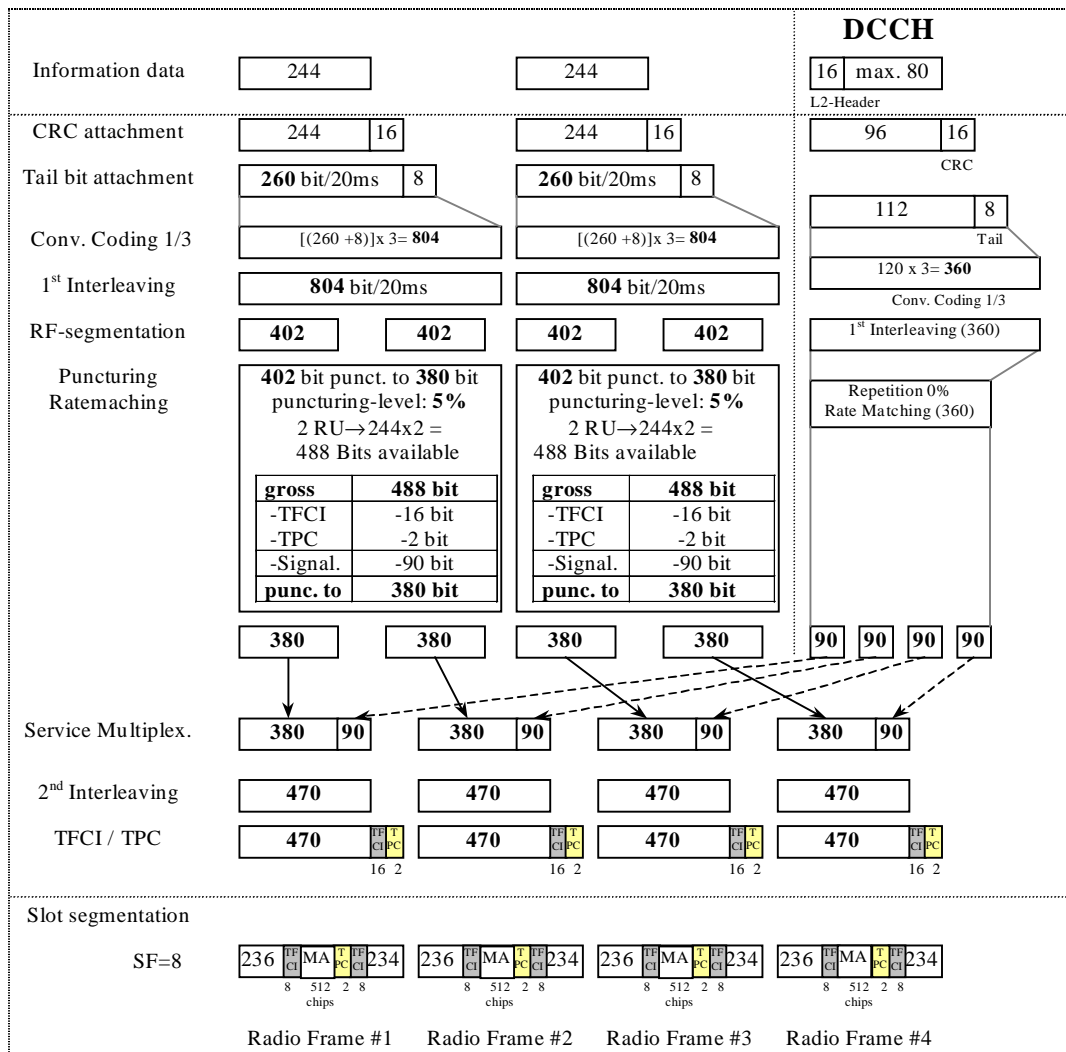

A.2.2 UL reference measurement channel (64 kbps)

| Parameter | |
|--|----------------------|
| Information data rate | 64 kbps |
| RU's allocated | 1 SF4 + 1 SF16 = 5RU |
| Midamble | 512 chips |
| Interleaving | 20 ms |
| Power control | 2 Bit/user |
| TFCI | 16 Bit/user |
| Inband signalling DCCH | 2 kbps |
| Puncturing level at Code rate : 1/3 DCH / 1/2 DCCH | 41.2% / 10% |

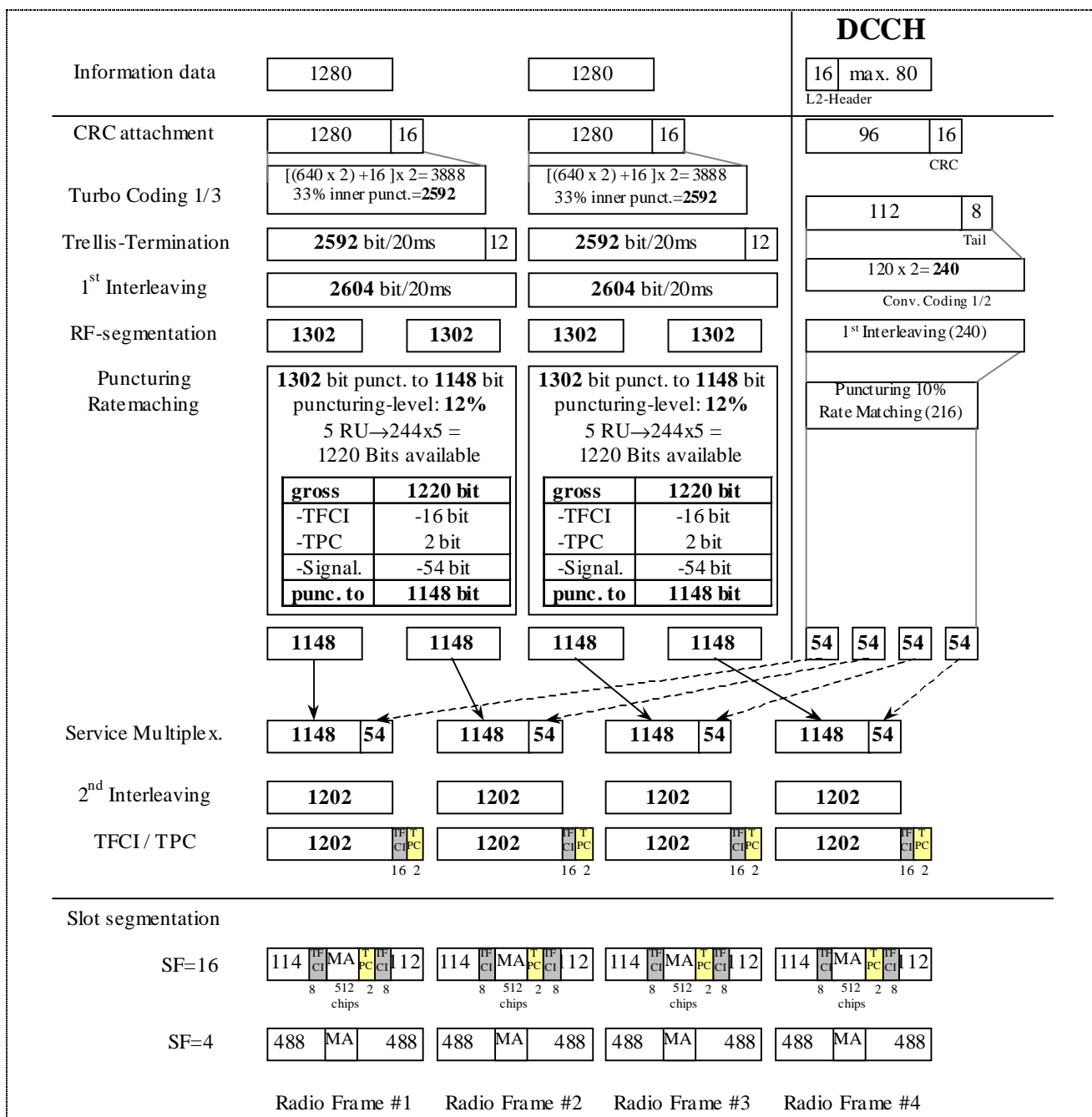

A.2.3 UL reference measurement channel (144 kbps)

| Parameter | |
|--|----------------------|
| Information data rate | 144 kbps |
| RU's allocated | 1 SF2 + 1 SF16 = 9RU |
| Midamble | 256 chips |
| Interleaving | 20 ms |
| Power control | 2 Bit/user |
| TFCI | 16 Bit/user |
| Inband signalling DCCH | 2 kbps |
| Puncturing level at Code rate : 1/3 DCH / 1/2 DCCH | 44.4% / 16.6% |

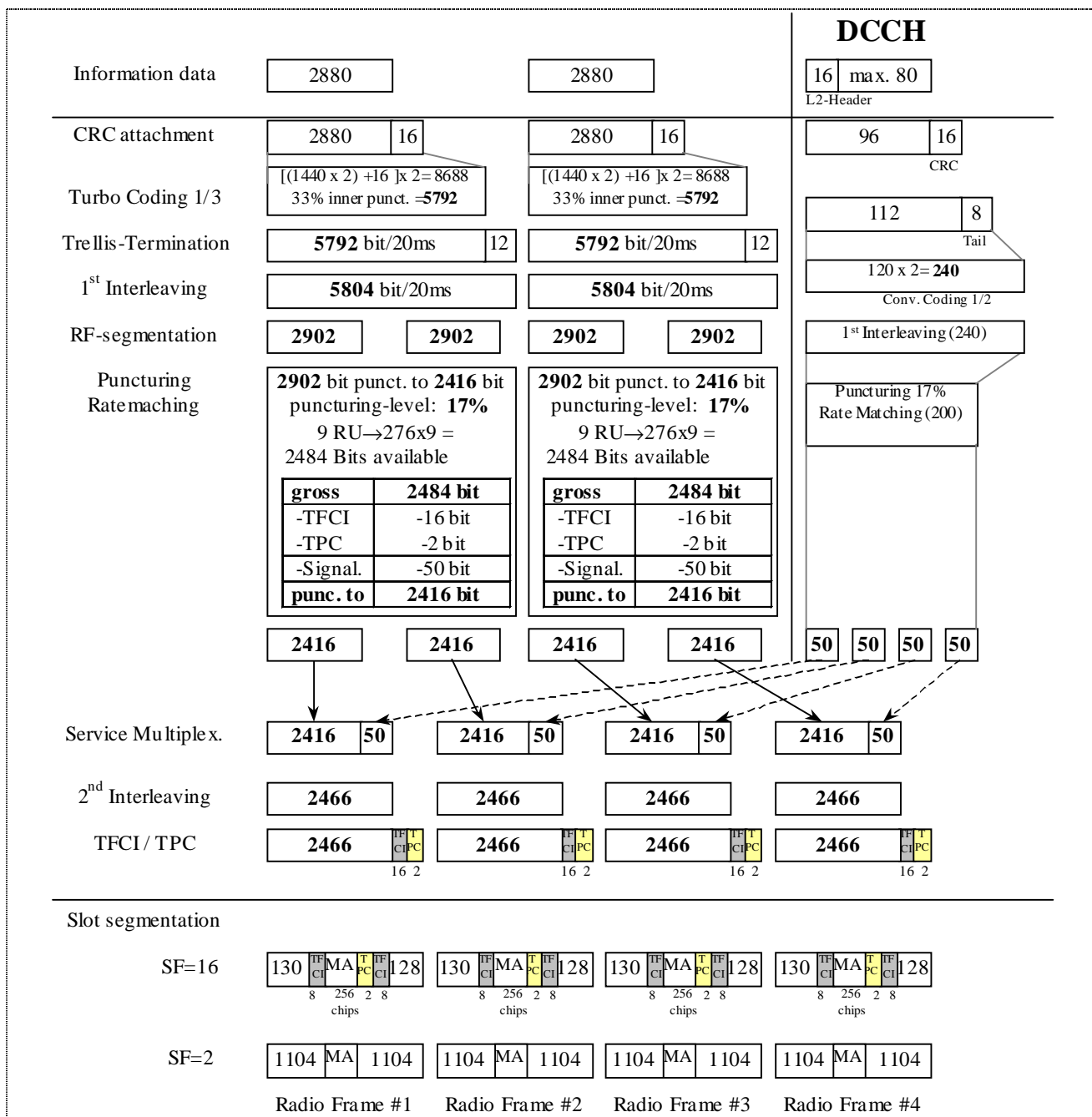

A.2.4 UL reference measurement channel (384 kbps)

| Parameter | |
|--|---------------|
| Information data rate | 384 kbps |
| RU's allocated | 8*3TS = 24RU |
| Midamble | 256 chips |
| Interleaving | 20 ms |
| Power control | 2 Bit/user |
| TFCI | 16 Bit/user |
| Inband signalling DCCH | 2 kbps |
| Puncturing level at Code rate : 1/3 DCH / 1/2 DCCH | 43.4% / 15.3% |

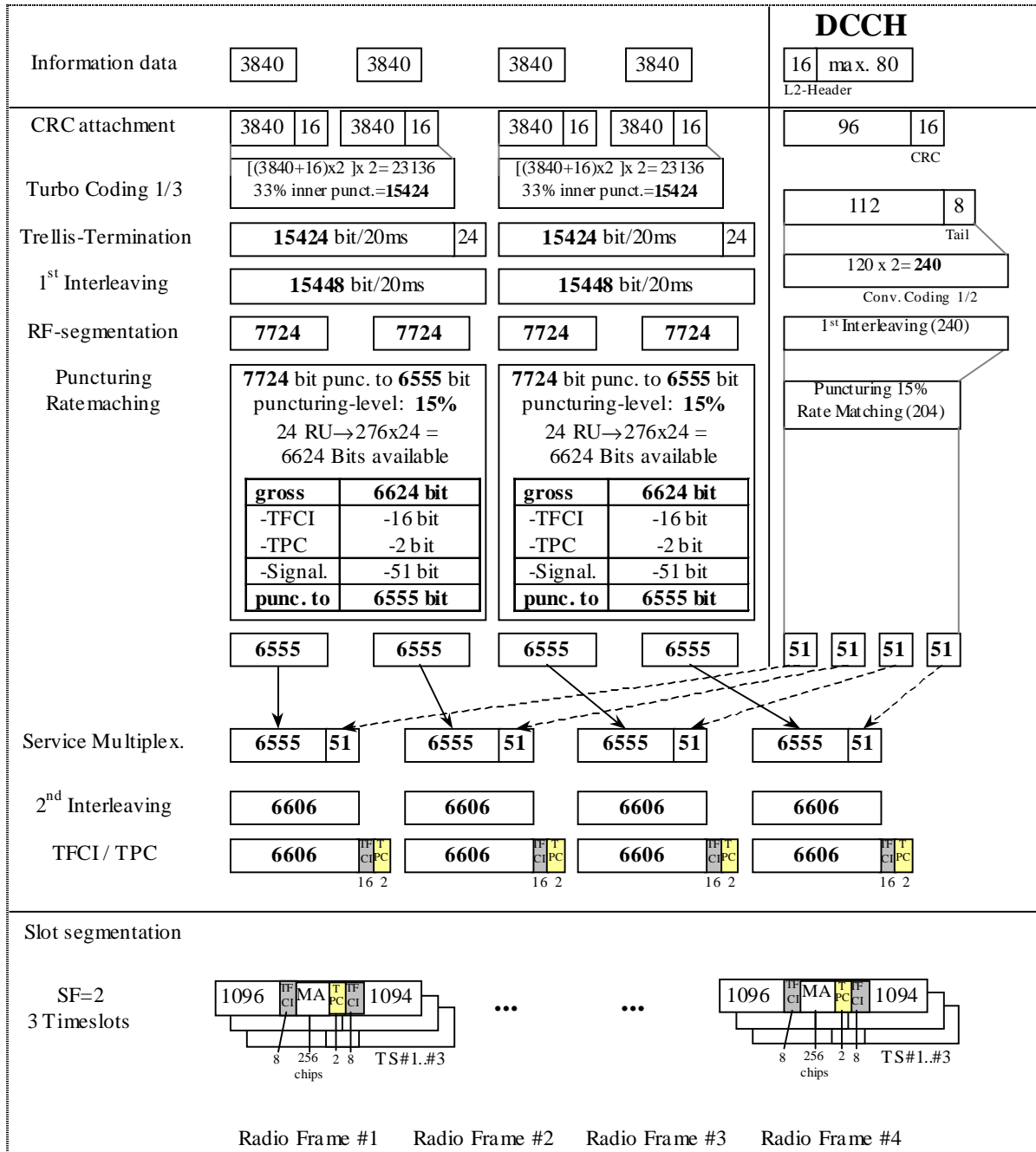

A.2.5 RACH reference measurement channel

| Parameter | |
|---|---------------------------|
| Information data rate e.g. 2 TBs ($B_{RACH}=2$): | |
| SF16: | |
| 0% puncturing rate at CR=1/2 | 46 bits per frame and TB |
| 10% puncturing rate at CR=1/2 | 53 bits per frame and TB |
| $N_{RACH} = \frac{232 + N_{RM} - 8}{B_{RACH}} - 8$ | |
| SF8: | |
| 0% puncturing rate at CR=1/2 | 96 bits per frame and TB |
| 10% puncturing rate at CR=1/2 | 109 bits per frame and TB |
| $N_{RACH} = \frac{464 + N_{RM} - 8}{B_{RACH}} - 16$ | |
| RU's allocated | 1 RU |
| Midamble | 512 chips |
| Power control | 0 bit |
| TFCI | 0 bit |

N_{RACH} = number of bits per TB

B_{RACH} = number of TBs

A.2.5.1 RACH mapped to 1 code SF16

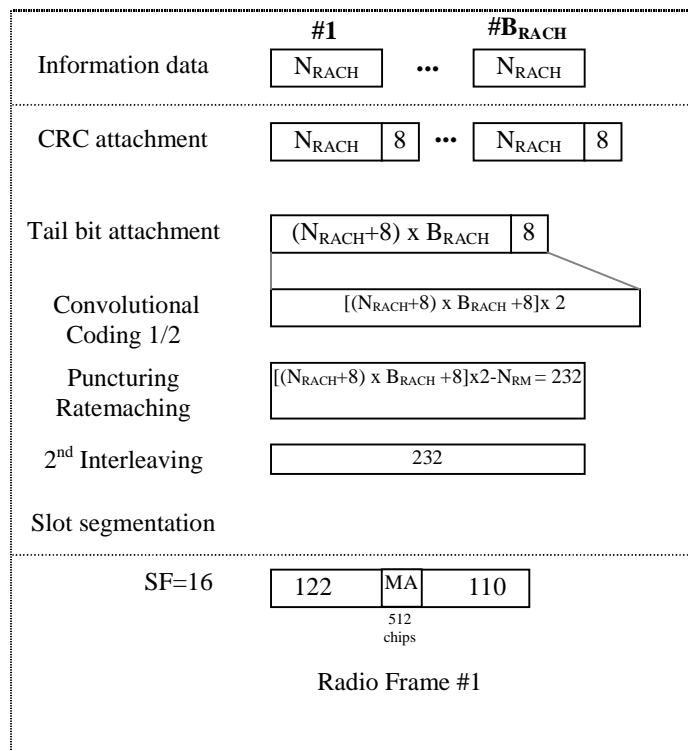

A.2.5.2 RACH mapped to 1 code SF8

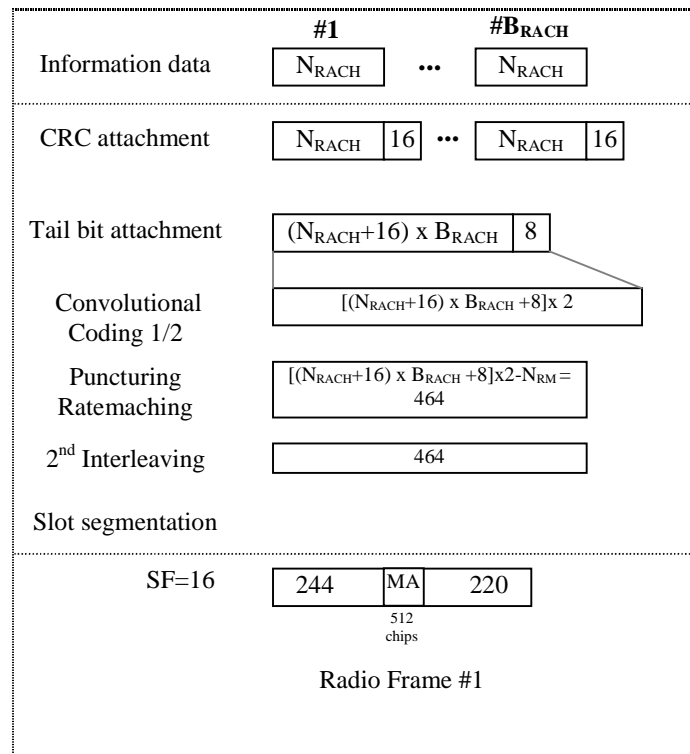

Annex B (normative): Propagation conditions

B.1 Static propagation condition

The propagation for the static performance measurement is an Additive White Gaussian Noise (AWGN) environment. No fading and multi-paths exist for this propagation model.

B.2 Multi-path fading propagation conditions

Table B1 shows propagation conditions that are used for the performance measurements in multi-path fading environment. All taps have classical Doppler spectrum.

Table B1: Propagation Conditions for Multi path Fading Environments

| Case 1, speed 3km/h | | Case 2, speed 3 km/h | | Case 3, 120 km/h | |
|---------------------|--------------------|----------------------|--------------------|---------------------|--------------------|
| Relative Delay [ns] | Average Power [dB] | Relative Delay [ns] | Average Power [dB] | Relative Delay [ns] | Average Power [dB] |
| 0 | 0 | 0 | 0 | 0 | 0 |
| 976 | -10 | 976 | 0 | 260 | -3 |
| | | 12000 | 0 | 521 | -6 |
| | | | | 781 | -9 |

Annex C (normative): Global in-channel Tx test

C.1 General

The global in-channel Tx test enables the measurement of all relevant parameters that describe the in-channel quality of the output signal of the Tx under test in a single measurement process.

C.2 Definition of the process

C.2.1 Basic principle

The process is based on the comparison of the actual **output signal of the Tx under test**, received by an ideal receiver, with a **reference signal**, that is generated by the measuring equipment and represents an ideal error free received signal. All signals are represented as equivalent (generally complex) baseband signals.

C.2.2 Output signal of the Tx under test

The output signal of the Tx under test is recorded through a matched filter (RRC 0.22, correct in shape and in position on the frequency axis) at one sample per chip.

Depending on the parameter to be evaluated, it is appropriate to represent the recorded signal in one of the following two different forms:

Form1 (representing the physical signal in the entire measurement interval):

one vector **Z**, containing $N = n \times m$ complex samples;

with

n : number of symbols in the measurement interval;

m : number of chips per symbol.

Form2 (derived from form 1 by separating the samples into symbol intervals):

n time sequential vectors **z** with m complex samples, where each vector comprises a symbol interval.

C.2.3 Reference signal

The reference signal is constructed by the measuring equipment according to the relevant Tx specifications, filtered by a matched filter and sampled at the Inter-Symbol-Interference-free instants.

Depending of the parameter to be evaluated, it is appropriate to represent the reference set of samples in one of the following three different forms:

Form1 (representing the physical signal in the entire measurement interval):

one vector **R**, containing $N = n \times m$ complex samples;

with

n: number of symbols in the measurement interval;

m: number of chips per symbol.

Form 2 (derived from form 1 by separating the samples into symbol intervals):

n time-sequential vectors \mathbf{r} with m complex samples, where each vector comprises a symbol interval.

(Note: Clarification is needed in case of a multi-code with multi-rate signal)

Form 3 (derived from form 2 by separating the samples into code signals):

n sequential expressions $\sum_{i=1}^k \mathbf{r}\mathbf{c}_i$,

with

k: number of codes;

a single summand $\mathbf{r}\mathbf{c}_i$ representing the vector of one code i, containing m complex samples of the symbol interval

C.2.4 Provisions in case of multi code signals

In case of multi code signals, the code multiplex shall contain only orthogonal codes. (Otherwise non-orthogonal codes must be eliminated (e.g. by time-windowing the measurement interval or switch off).

C.2.5 Classification of measurement results

The measurement results achieved by the global in-channel Tx test can be classified into two types:

Results of type 1, where the error-free parameter has a non-zero magnitude. These parameters are:

RF Frequency

(Chip Frequency)

Power

Code Domain Power (in case of multi code)

Timing (only for MS)

Results of type 2, where the error-free parameter has value zero. These parameters are:

Error Vector Magnitude

Peak Code Domain Power Error

C.2.6 Process definition to achieve results of type 1

The reference signal is varied with respect to the parameters mentioned in subclause C.2.5 under "results of type 1" in order to achieve best fit with the recorded signal under test (output signal of the Tx under test, filtered and sampled

according to subclause C.2.2). Best fit is achieved when the RMS difference value between the signal under test and the varied reference signal is an absolute minimum. The varied reference signal in this best fit case will be called \mathbf{R}' .

The varied parameters leading to \mathbf{R}' represent directly the wanted results of type 1. These measurement parameters are expressed as deviation from the reference value with dimensions same as the reference value.

In case of multi code, the type-1-parameters (frequency, (chip frequency) and timing) are varied commonly for all codes such that the process returns one frequency-error, (one chip-frequency error), one timing error.

(These parameters are not varied on the individual codes signals such that the process returns k frequency errors... (k: number of codes)).

Only the type-1-parameters (code powers) are varied individually such that the process returns k code powers (k: number of codes)

C.2.7 Process definition to achieve results of type 2

The difference between the signal under test (\mathbf{Z} ; see subclause C.2.2) and the reference signal after the minimum process (\mathbf{R}' ; see subclause C.2.6) is the error vector \mathbf{E} versus time:

$$\mathbf{E} = \mathbf{Z} - \mathbf{R}'.$$

Depending on the parameter to be evaluated, it is appropriate to represent \mathbf{E} in one of the following two different forms:

Form 1 (representing the physical error signal in the entire measurement interval):

One vector \mathbf{E} , containing $N = n \times m$ complex samples;

with

n: number of symbols in the measurement interval

m: number of chips per symbol

Form 2 (derived from form 1 by separating the samples into symbol intervals):

n time-sequential vectors \mathbf{e} with m complex samples comprising one symbol interval

\mathbf{E} gives results of type 2 applying the two algorithms defined in subclauses C.2.7.1 and C.2.7.2.

C.2.7.1 Error Vector Magnitude

The Error Vector Magnitude EVM is calculated according to the following steps:

- (1) Take the error vector \mathbf{E} defined in subclause C.2.7 (form 1) and calculate the RMS value of \mathbf{E} chip-wise over the entire measurement interval; the result will be called $\text{RMS}(\mathbf{E})$.
- (2) Take the reference vector \mathbf{R} defined in subclause C.2.3 (form 1) and calculate the RMS value of \mathbf{R} chip-wise over the entire measurement interval; the result will be called $\text{RMS}(\mathbf{R})$
- (3) Calculate EVM according to

$$\text{EVM} = \frac{\text{RMS}(\mathbf{E})}{\text{RMS}(\mathbf{R})} \times 100\%$$

(here, EVM is relative and expressed in %)

C.2.7.2 Peak Code Domain Power Error

The Peak Code Domain Power Error is calculated according to the following steps:

- (1) Take the error vectors \mathbf{e} defined in subclause C.2.7 (form 2) and the reference vectors \mathbf{rc}_i defined in subclause C.2.3 (form 3) and calculate the inner product of \mathbf{e} and \mathbf{rc}_i chip-wise over the symbol duration for all symbols of the measurement interval and for all permitted codes of the code space.

This gives a matrix of format $k \times n$, each value representing an error voltage connected with a specific symbol and a specific code, which can be exploited in a large variety.

k: number of codes

n: number of symbols in the measurement interval

- (2) Calculate k RMS values, each RMS value unifying n symbols within one code.

(This values can be called "absolute Code-EVMs" [Volt].)

- (3) Find the peak value among the k "absolute Code-EVMs".

(This value can be called "absolute Peak-Code-EVM" [Volt].)

- (4) Calculate the following term:

$$10 \lg \frac{(\text{absolute Peak - Code - EVM})^2}{(\text{RMS}(\mathbf{R}))^2} \text{ dB}.$$

This term is called Peak Code Domain Power Error (a relative value in dB).

- (5) If the values $\text{RMS}(\mathbf{r})$ are not constant during the measurement interval, Peak Code Domain Power Error should be expressed absolutely instead by the term:

$$\frac{(\text{absolute Peak - Code - EVM})^2}{50 \text{ Ohm}}$$

This term is called Absolute Peak Code Domain Power Error [Watt or dBm]

C.3 Applications

This process is applicable to the following paragraphs:

- 6.3 Frequency Stability
- 6.4 Output Power Dynamics
- 6.5 Transmit OFF Power
- 6.8 Transmit Modulation
[Chip Frequency]

History

| Document history | | |
|--|------------|---|
| V0.0.1 | 1999-06-14 | First draft, based on text blocks taken from prI-ETS 300 609-1, 3GPP TS 25.141V0.1.0 |
| V0.1.0 | 1999-07-02 | Incorporation of amendments agreed at RAN WG4#5 in Miami |
| V1.0.0 | 1999-07-28 | Document status raised to V1.0.0 at RAN WG4#6 in South Queensferry. Content identical with the previous release V0.1.0. |
| V1.1.0 | 1999-08-26 | Incorporation of amendments agreed at RAN WG4#6 in South Queensferry |
| V2.0.0 | 1999-09-16 | Incorporation of amendments agreed at RAN WG4#7 in Makuhari, Japan |
| V2.0.0 | 1999-10-07 | Endorsed by TSG-RAN#5 |
| V2.1.0 | 1999-11-09 | Incorporation of amendments agreed at RAN WG4#8 in Sophia Antipolis, France |
| V2.2.0 | 1999-12-09 | Incorporation of amendments agreed at RAN WG4#9 in Bath, UK |
| <p>Editor for 3G TS 24.142 (Base station conformance testing (TDD)) is</p> <p>Juergen Meyer</p> <p>Siemens AG</p> <p>Tel.: +49 89 722 42545</p> <p>Fax: +49 89 722 24354</p> <p>E-mail: juergen.meyer@icn.siemens.de</p> <p>This document is written in Microsoft Word 97.</p> | | |