

3GPP TSG CN Plenary Meeting #24
2nd – 4th June 2004 Seoul, KOREA.

NP-040214

Source: TSG CN WG4
Title: Corrections on OoBTC Rel-4
Agenda item: 7.7
Document for: APPROVAL

Spec	CR	Rev	Doc-2nd-Level N4-040	Phase	Subject	Cat	Ver_C
23.153	070	1	718	Rel-4	Correction of Codec Negotiation and supported codec mode configurations	F	4.9.0
23.153	071	1	719	Rel-5	Correction of Codec Negotiation and supported codec mode configurations	A	5.7.0

CR-Form-v7	
CHANGE REQUEST	
⌘ 23.153 CR 072 ⌘ rev - ⌘	Current version: 5.7.0 ⌘

For **HELP** on using this form, see bottom of this page or look at the pop-up text over the ⌘ symbols.

Proposed change affects: UICC apps ME Radio Access Network Core Network

Title:	⌘ Correction to section 6.5 on information flow after UMTS to GSM handover		
Source:	⌘ LM Ericsson		
Work item code:	⌘ OoBTC	Date:	⌘ 27/04/04
Category:	⌘ F	Release:	⌘ Rel-5
	Use <u>one</u> of the following categories: F (correction) A (corresponds to a correction in an earlier release) B (addition of feature), C (functional modification of feature) D (editorial modification) Detailed explanations of the above categories can be found in 3GPP TR 21.900 .		Use <u>one</u> of the following releases: 2 (GSM Phase 2) R96 (Release 1996) R97 (Release 1997) R98 (Release 1998) R99 (Release 1999) Rel-4 (Release 4) Rel-5 (Release 5) Rel-6 (Release 6)

Reason for change:	⌘ Inter-MSC OoBTC signalling has been introduced for handover but there is till text not corrected in section 6.5 that contradicts this. This is an essential correction.
Summary of change:	⌘ Text that states that codec negotiation prior to Inter-MSC handover cannot be performed is corrected.
Consequences if not approved:	⌘ Contradicts text in clause 6.11

Clauses affected:	⌘ 6.5						
Other specs affected:	<table border="1" style="display: inline-table; border-collapse: collapse;"> <tr> <td style="width: 20px; text-align: center;">Y</td> <td style="width: 20px; text-align: center;">N</td> </tr> <tr> <td style="text-align: center;"><input type="checkbox"/></td> <td style="text-align: center;"><input checked="" type="checkbox"/></td> </tr> </table> Other core specifications	Y	N	<input type="checkbox"/>	<input checked="" type="checkbox"/>	⌘	
Y	N						
<input type="checkbox"/>	<input checked="" type="checkbox"/>						
	<table border="1" style="display: inline-table; border-collapse: collapse;"> <tr> <td style="width: 20px; text-align: center;">Y</td> <td style="width: 20px; text-align: center;">N</td> </tr> <tr> <td style="text-align: center;"><input type="checkbox"/></td> <td style="text-align: center;"><input checked="" type="checkbox"/></td> </tr> </table> Test specifications	Y	N	<input type="checkbox"/>	<input checked="" type="checkbox"/>	⌘	
Y	N						
<input type="checkbox"/>	<input checked="" type="checkbox"/>						
	<table border="1" style="display: inline-table; border-collapse: collapse;"> <tr> <td style="width: 20px; text-align: center;">Y</td> <td style="width: 20px; text-align: center;">N</td> </tr> <tr> <td style="text-align: center;"><input type="checkbox"/></td> <td style="text-align: center;"><input checked="" type="checkbox"/></td> </tr> </table> O&M Specifications	Y	N	<input type="checkbox"/>	<input checked="" type="checkbox"/>	⌘	
Y	N						
<input type="checkbox"/>	<input checked="" type="checkbox"/>						
Other comments:	⌘						

How to create CRs using this form:

Comprehensive information and tips about how to create CRs can be found at <http://www.3gpp.org/specs/CR.htm>. Below is a brief summary:

- 1) Fill out the above form. The symbols above marked ⌘ contain pop-up help information about the field that they are closest to.
- 2) Obtain the latest version for the release of the specification to which the change is proposed. Use the MS Word "revision marks" feature (also known as "track changes") when making the changes. All 3GPP specifications can be downloaded from the 3GPP server under <ftp://ftp.3gpp.org/specs/> For the latest version, look for the directory name with the latest date e.g. 2001-03 contains the specifications resulting from the March 2001 TSG meetings.

- 3) With "track changes" disabled, paste the entire CR form (use CTRL-A to select it) into the specification just in front of the clause containing the first piece of changed text. Delete those parts of the specification which are not relevant to the change request.

6.5 Information flow for handover from UMTS to GSM after TrFO establishment

Inter-system handover procedures are described at call control level in [11] and details for bearer independent architecture is described in [8]. For TrFO connected UMTS call, when a handover occurs to GSM radio access, by definition the A-interface to the BSC shall be default PCM. Prior to receipt of Handover Detect the Anchor MGW has one leg (A-interface) stream mode as default PCM and two terminations with compressed voice codec properties. It is recommended that after the Handover Complete procedure, the network property is maintained as compressed. Thus the Anchor MGW inserts a "TFO Partner" transcoder. Thus no modification to the compressed bearer to 64k PCM is required. TFO procedures may then ensure that speech quality is maintained by avoiding transcoding.

In the Intra-MSC case shown in Figure 6.5/1 the MSC controlling the handover has both codec lists for each radio access. The codec negotiation for the UMTS call was performed end to end with UMTS list. If this negotiation resulted in a codec being selected that is also included in the GSM list then at handover the MSC shall indicate this codec as the current speech version to the BSC and TFO can be achieved. If the selected codec is not supported for the GSM radio access but the GSM list contains a codec that is also in the Available Codecs list then the MSC has the option to perform codec modification to ensure TFO can be achieved. The MSC may also perform codec list modification by sending forward the GSM list to update nodes in the network of the change to the Available Codecs List.

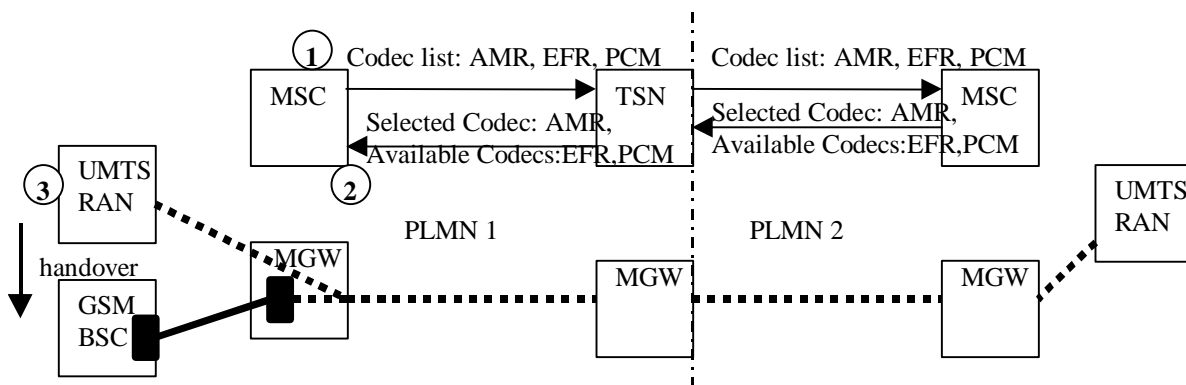

Figure 6.5/1: UMTS to GSM Inter-System Handover

If the Inter-system handover is an inter-MSC handover then the Anchor MSC sends the current speech version and the supported speech versions in the Prepare Handover Request message to the MSC-B. If the current speech version (codec selected for UMTS call) is not included in the GSM list then the MSC-A shall indicate a preferred codec in the current speech version parameter. The speech version for the GSM access that is finally selected by the MSC-B's BSS, is returned to MSC-A in the Prepare Handover Response message. The MSC-A can then decide if codec modification or codec re-negotiation shall be performed as described for the intra-MSC case. ~~The MSC-B shall always assume default PCM across the E-interface, as there is no possibility to perform codec negotiation prior to performing the handover.~~ For further details on the inter-MSC signalling see section 6.11. The connections are shown in Figure 6.5/2.

CR-Form-v7

CHANGE REQUEST

⌘ **23.153 CR 070** ⌘ rev **1** ⌘ Current version: **4.9.0** ⌘

For **HELP** on using this form, see bottom of this page or look at the pop-up text over the ⌘ symbols.

Proposed change affects: UICC apps ME Radio Access Network Core Network

Title:	⌘ Correction of Codec Negotiation and supported codec mode configurations		
Source:	⌘ CN4		
Work item code:	⌘ OoBTC	Date:	⌘ 27/04/2004
Category:	⌘ F	Release:	⌘ Rel-4
	Use <u>one</u> of the following categories:		Use <u>one</u> of the following releases:
	F (correction)		2 (GSM Phase 2)
	A (corresponds to a correction in an earlier release)		R96 (Release 1996)
	B (addition of feature),		R97 (Release 1997)
	C (functional modification of feature)		R98 (Release 1998)
	D (editorial modification)		R99 (Release 1999)
	Detailed explanations of the above categories can be found in 3GPP TR 21.900 .		Rel-4 (Release 4)
			Rel-5 (Release 5)
			Rel-6 (Release 6)

Reason for change:	⌘ Essential correction. Real-world UTRAN implementations support only a limited number of codec mode configurations. This means: - only certain codec mode configurations (sets of codec modes) are supported; - subsets of these sets of codec modes may not be supported; - codec modes supported within a codec mode configuration are not necessarily supported as single mode. In order to increase the chance for the successful setup of a TrFO connection, the originating CN node needs to inform the terminating CN node about the different codec mode configurations supported for the same codec type by including more than one "Single codec" element with the same codec type. Currently the standard does not allow this explicitly. Since within the RNCs the different codec mode configurations are introduced step by step, the correction is needed especially during the introduction phase, i.e. it is imperative for 3GPP Rel-4 and Rel-5.
Summary of change:	⌘ The MSC-S may include more than one "Single codec" element indicating the same codec type, but different configurations, in the codec list.
Consequences if not approved:	⌘ If the specification remains unclear, the following interoperability problem can occur between different implementations: MSC implementation 1 regularly sends a Supported Codec List containing more than one "Single codec" element indicating the same codec type, but different

configurations.

MSC implementation 2 is not prepared to handle a Supported Codec List containing more than one "Single codec" element indicating the same codec type.

As a consequence, dependent on the details of MSC implementation 2, the codec negotiation may fail frequently and TrFO cannot be established or, in the worst case, even the call setup may fail.

If the correction is delayed to 3GPP Rel-6, the interworking with 3GPP Rel-4 and Rel-5 will not work, since the descriptions of the codec handling are different.

Clauses affected: ⌘ 5.6

Other specs affected:

Y	N
<input checked="" type="checkbox"/>	<input type="checkbox"/>
<input checked="" type="checkbox"/>	<input type="checkbox"/>
<input checked="" type="checkbox"/>	<input type="checkbox"/>

Other core specifications

Test specifications

O&M Specifications

Other comments: ⌘

How to create CRs using this form:

Comprehensive information and tips about how to create CRs can be found at <http://www.3gpp.org/specs/CR.htm>.

Below is a brief summary:

- 1) Fill out the above form. The symbols above marked ⌘ contain pop-up help information about the field that they are closest to.
- 2) Obtain the latest version for the release of the specification to which the change is proposed. Use the MS Word "revision marks" feature (also known as "track changes") when making the changes. All 3GPP specifications can be downloaded from the 3GPP server under <ftp://ftp.3gpp.org/specs/> For the latest version, look for the directory name with the latest date e.g. 2001-03 contains the specifications resulting from the March 2001 TSG meetings.
- 3) With "track changes" disabled, paste the entire CR form (use CTRL-A to select it) into the specification just in front of the clause containing the first piece of changed text. Delete those parts of the specification which are not relevant to the change request.

***** FIRST MODIFIED SECTION *****

5.6 CN Node handling of Codec Types & Codec Modes

The supported codec list received by the MSC in DTAP protocol [2] has no priority, whereas the list sent in the OoBTC procedures is sent with a level of preference.

The default Codec Type for “R99 UMTS only” terminals is UMTS_AMR, the default Codec Type for all terminals supporting GSM and UMTS radio access is UMTS_AMR_2, see [5] for the detailed description. The UMTS_AMR_2 is a superset of the UMTS_AMR. It behaves as a FR_AMR codec in the UL and as a UMTS_AMR codec in the DL. This allows UMTS terminals to operate in TFO with GSM terminals. The UMTS_AMR_2 is fully compatible with UMTS_AMR in TFO and TrFO and fully compatible with R99 CN nodes (TC in MGW).

If the UE supports both Codec Types (UMTS_AMR and UMTS_AMR_2), then the MSC shall indicate only the UMTS_AMR_2 in the OoBTC codec negotiation. If no Codec List IE is received and the UE is “UMTS only”, then the MSC shall assume UMTS_AMR as supported Codec Type. If no Codec List IE is received, but the UE is “dual system”, then the MSC shall assume UMTS_AMR_2 as the supported codec type. The MSC shall assume “dual system” support only if the UE indicates at least one GSM speech version in Octet 3a etc. of the Bearer Capability.

When a codec list contains UMTS_AMR_2 and a node in the network participating in the codec negotiation only supports UMTS_AMR then it shall indicate UMTS_AMR back although the codepoints as defined in [5] are different and only the UMTS_AMR_2 codepoint is included in the codec list it shall be allowed to signal back the codepoint for UMTS_AMR as this is a subset of the UMTS_AMR_2 codec and thus its support is implied. Similarly, if a node receives only UMTS_AMR in the codec list but it supports UMTS_AMR_2 it shall reply with the codepoint for UMTS_AMR as this is the subset that is compatible.

[The MSC may include more than one "Single codec" element indicating the same codec type, but different configurations, in the codec list \(see \[5\]\).](#)

[NOTE: This may be necessary if the RNC supports for an adaptive multi-rate codec different sets of codec modes, e.g., \(a, b, c, d\) and \(e, f, g\), which are not subsets of each other, and the RNC does not support combinations of these sets, e.g. \(a, b, c, d, e, f, g\).](#)

[The MSC Server shall know the codec mode configurations supported by the RNC. These configurations shall be considered during the speech codec negotiation and the RAB Assignment.](#)

In order to support interworking with 2G systems it is recommended that MGWs support 2G EFR codecs (GSM_EFR, PDC_EFR, TDMA_EFR). In order to avoid modifications during handover between 2G and 3G systems the MSC nodes may give preference to a suitable 2G codec.

The originating CN node, while performing speech service negotiation with a terminating CN node, shall indicate the maximum number of codec modes that shall be selected during speech codec negotiation. This maximum number of supported codec modes may depend on optimisation strategies applied by the originating CN node. The recommended value is “four” (see [10]).

The terminating CN node receiving this information compares the maximum number of codec modes received by the originating CN with its own one and shall decide on the minimum of both numbers to be applied as result of the negotiation.

The decision about the actual codec modes to be selected as the Active Codec Set (ACS) shall be left to the terminating CN node. In order to provide harmonisation of out of band codec negotiation (TrFO) and inband codec negotiation (TFO) very similar codec selection mechanisms as those being defined for TFO shall be applied for TrFO, see [10]. These rules shall be taken into account when forwarding a codec list from the originating node to proceeding node, both for TrFO and TFO.

Whenever one or several TrFO links have been already established and initialised, the CN node (e.g. the serving CN in case of Call Hold scenarios, the visited CN node in case of Call Forwarding scenarios, etc.) initiating a subsequent codec negotiation, shall give the already negotiated codec type, including its ACS, highest preference to reduce the possibility of performing bearer re-establishment or UP re-initialisation of the already established and initialised TrFO links.

When the MSC node requests a RAB assignment the Subflow Combinations provided shall either all be initialised by the RNC or all rejected with appropriate cause code.

The MSC shall always assume "Discontinuous Transmission (DTX)" as mandatory and shall define "SID" SDUs in addition to the negotiated speech codec modes. This is because for TrFO the RAB requested by one RNC must match that requested by the peer RNC – they are effectively the same RAB. If one MSC requires DTX support then the RAB requested by the far end MSC must also support DTX (even if it is not desired by that MSC). As no Out Of Band negotiation for DTX is supported nor DTX control to the UE, DTX shall be mandatory for TrFO connections.

Once the common ACS has been selected the MSCs shall indicate in the RAB Assignment parameters [3] for the Guaranteed Bitrate the lowest speech mode in the ACS (assuming any SID frames are smaller than the SDU for lowest speech mode, otherwise the Guaranteed Bitrate shall be set to the largest SID frame). The Maximum bitrate shall correspond to the highest mode in the ACS.

CR-Form-v7

CHANGE REQUEST

⌘ 23.153 CR 071 ⌘ rev 1 ⌘ Current version: 5.7.0 ⌘

For **HELP** on using this form, see bottom of this page or look at the pop-up text over the ⌘ symbols.

Proposed change affects: UICC apps ME Radio Access Network Core Network

Title:	⌘ Correction of Codec Negotiation and supported codec mode configurations		
Source:	⌘ CN4		
Work item code:	⌘ OoBTC	Date:	⌘ 27/4/2004
Category:	⌘ A	Release:	⌘ Rel-5
	Use <u>one</u> of the following categories:		Use <u>one</u> of the following releases:
	F (correction)		2 (GSM Phase 2)
	A (corresponds to a correction in an earlier release)		R96 (Release 1996)
	B (addition of feature),		R97 (Release 1997)
	C (functional modification of feature)		R98 (Release 1998)
	D (editorial modification)		R99 (Release 1999)
	Detailed explanations of the above categories can be found in 3GPP TR 21.900 .		Rel-4 (Release 4)
			Rel-5 (Release 5)
			Rel-6 (Release 6)

Reason for change:	⌘ Essential correction. Real-world UTRAN implementations support only a limited number of codec mode configurations. This means: - only certain codec mode configurations (sets of codec modes) are supported; - subsets of these sets of codec modes may not be supported; - codec modes supported within a codec mode configuration are not necessarily supported as single mode. In order to increase the chance for the successful setup of a TrFO connection, the originating CN node needs to inform the terminating CN node about the different codec mode configurations supported for the same codec type by including more than one "Single codec" element with the same codec type. Currently the standard does not allow this explicitly. Since within the RNCs the different codec mode configurations are introduced step by step, the correction is needed especially during the introduction phase, i.e. it is imperative for 3GPP Rel-4 and Rel-5.
Summary of change:	⌘ The MSC-S may include more than one "Single codec" element indicating the same codec type, but different configurations, in the codec list.
Consequences if not approved:	⌘ If the specification remains unclear, the following interoperability problem can occur between different implementations: MSC implementation 1 regularly sends a Supported Codec List containing more than one "Single codec" element indicating the same codec type, but different

configurations.

MSC implementation 2 is not prepared to handle a Supported Codec List containing more than one "Single codec" element indicating the same codec type.

As a consequence, dependent on the details of MSC implementation 2, the codec negotiation may fail frequently and TrFO cannot be established or, in the worst case, even the call setup may fail.

If the correction is delayed to 3GPP Rel-6, the interworking with 3GPP Rel-4 and Rel-5 will not work, since the descriptions of the codec handling are different.

Clauses affected: ⌘ 5.6

Other specs affected:

Y	N
<input checked="" type="checkbox"/>	<input type="checkbox"/>
<input checked="" type="checkbox"/>	<input type="checkbox"/>
<input checked="" type="checkbox"/>	<input type="checkbox"/>

Other core specifications

Test specifications

O&M Specifications

Other comments: ⌘

How to create CRs using this form:

Comprehensive information and tips about how to create CRs can be found at <http://www.3gpp.org/specs/CR.htm>.

Below is a brief summary:

- 1) Fill out the above form. The symbols above marked ⌘ contain pop-up help information about the field that they are closest to.
- 2) Obtain the latest version for the release of the specification to which the change is proposed. Use the MS Word "revision marks" feature (also known as "track changes") when making the changes. All 3GPP specifications can be downloaded from the 3GPP server under <ftp://ftp.3gpp.org/specs/> For the latest version, look for the directory name with the latest date e.g. 2001-03 contains the specifications resulting from the March 2001 TSG meetings.
- 3) With "track changes" disabled, paste the entire CR form (use CTRL-A to select it) into the specification just in front of the clause containing the first piece of changed text. Delete those parts of the specification which are not relevant to the change request.

***** FIRST MODIFIED SECTION *****

5.6 CN Node handling of Codec Types & Codec Modes

The supported codec list received by the MSC in DTAP protocol [2] has no priority, whereas the list sent in the OoBTC procedures is sent with a level of preference.

The default Codec Type for “R99 UMTS only” terminals is UMTS_AMR, the default Codec Type for all terminals supporting GSM and UMTS radio access is UMTS_AMR_2, see [5] for the detailed description. The UMTS_AMR_2 is a superset of the UMTS_AMR. It behaves as a FR_AMR codec in the UL and as a UMTS_AMR codec in the DL. This allows UMTS terminals to operate in TFO with GSM terminals. The UMTS_AMR_2 is fully compatible with UMTS_AMR in TFO and TrFO and fully compatible with R99 CN nodes (TC in MGW).

If the UE supports both Codec Types (UMTS_AMR and UMTS_AMR_2), then the MSC shall indicate only the UMTS_AMR_2 in the OoBTC codec negotiation. If no Codec List IE is received and the UE is “UMTS only”, then the MSC shall assume UMTS_AMR as supported Codec Type. If no Codec List IE is received, but the UE is “dual system”, then the MSC shall assume UMTS_AMR_2 as the supported codec type. The MSC shall assume “dual system” support only if the UE indicates at least one GSM speech version in Octet 3a etc. of the Bearer Capability.

When a codec list contains UMTS_AMR_2 and a node in the network participating in the codec negotiation only supports UMTS_AMR then it shall indicate UMTS_AMR back. although the codepoints as defined in [5] are different and only the UMTS_AMR_2 codepoint is included in the codec list it shall be allowed to signal back the codepoint for UMTS_AMR as this is a subset of the UMTS_AMR_2 codec and thus its support is implied. Similarly, if a node receives only UMTS_AMR in the codec list but it supports UMTS_AMR_2 it shall reply with the codepoint for UMTS_AMR as this is the subset that is compatible.

The MSC may include more than one "Single codec" element indicating the same codec type, but different configurations, in the codec list (see [5]).

NOTE: This may be necessary if the RNC supports for an adaptive multi-rate codec different sets of codec modes, e.g., (a, b, c, d) and (e, f, g), which are not subsets of each other, and the RNC does not support combinations of these sets, e.g. (a, b, c, d, e, f, g).

The MSC Server shall know the codec mode configurations supported by the RNC. These configurations shall be considered during the speech codec negotiation and the RAB Assignment.

In order to support interworking with 2G systems it is recommended that MGWs support 2G EFR codecs (GSM_EFR, PDC_EFR, TDMA_EFR). In order to avoid modifications during handover between 2G and 3G systems the MSC nodes may give preference to a suitable 2G codec.

For GERAN Iu-mode the MSC Server receives a list of codec types (for definition see [15]) as well as the supported codec modes (for an adaptive multi-rate codec type) within the RANAP INITIAL UE MESSAGE, indicating the GERAN capabilities, which will be available at the RAB establishment procedure. With this information the MSC Server shall puncture out (i.e. delete) those codec types and codec modes (for an adaptive multi-rate codec type) from the supported codec list (for definition see [5]) taking into account the GERAN classmark and the MS capabilities which are not supported by the GERAN. This possibly reduced list shall be used by the MSC Server during the negotiation procedure as described in clause 5.1. The value of the maximum number of supported codec modes shall be set to "four" (see [10]).

The originating CN node, while performing speech service negotiation with a terminating CN node, shall indicate the maximum number of codec modes that shall be selected during speech codec negotiation. This maximum number of supported codec modes may depend on optimisation strategies applied by the originating CN node. The recommended value is “four” (see [10]).

The terminating CN node receiving this information compares the maximum number of codec modes received by the originating CN with its own one and shall decide on the minimum of both numbers to be applied as result of the negotiation.

The decision about the actual codec modes to be selected as the Active Codec Set (ACS) shall be left to the terminating CN node. In order to provide harmonisation of out of band codec negotiation (TrFO) and inband codec negotiation (TFO) very similar codec selection mechanisms as those being defined for TFO shall be applied for TrFO, see [10]. These rules shall be taken into account when forwarding a codec list from the originating node to proceeding node, both for TrFO and TFO.

Whenever one or several TrFO links have been already established and initialised, the CN node (e.g. the serving CN in case of Call Hold scenarios, the visited CN node in case of Call Forwarding scenarios, etc.) initiating a subsequent codec negotiation, shall give the already negotiated codec type, including its ACS, highest preference to reduce the possibility of performing bearer re-establishment or UP re-initialisation of the already established and initialised TrFO links.

When the MSC node requests a RAB assignment the Subflow Combinations provided shall either all be initialised by the RNC or all rejected with appropriate cause code.

The MSC shall always assume "Discontinuous Transmission (DTX)" as mandatory and shall define "SID" SDUs in addition to the negotiated speech codec modes. This is because for TrFO the RAB requested by one RNC must match that requested by the peer RNC – they are effectively the same RAB. If one MSC requires DTX support then the RAB requested by the far end MSC must also support DTX (even if it is not desired by that MSC). As no Out Of Band negotiation for DTX is supported nor DTX control to the UE, DTX shall be mandatory for TrFO connections.

Once the common ACS has been selected the MSCs shall indicate in the RAB Assignment parameters [3] for the Guaranteed Bitrate the lowest speech mode in the ACS (assuming any SID frames are smaller than the SDU for lowest speech mode, otherwise the Guaranteed Bitrate shall be set to the largest SID frame). The Maximum bitrate shall correspond to the highest mode in the ACS.