

CHANGE REQUEST

⌘ **33.220 CR 026** ⌘ rev **-** ⌘ Current version: **6.2.0** ⌘

For **HELP** on using this form, see bottom of this page or look at the pop-up text over the ⌘ symbols.

Proposed change affects: | UICC apps ME Radio Access Network Core Network

Title:	⌘ GBA_U: storage of Ks_ext in the UICC		
Source:	⌘ Gemplus, Axalto, Oberthur		
Work item code:	⌘ SEC1-SC	Date:	⌘ 27/09/04
Category:	⌘ C	Release:	⌘ Rel-6
	Use <u>one</u> of the following categories: F (correction) A (corresponds to a correction in an earlier release) B (addition of feature), C (functional modification of feature) D (editorial modification) Detailed explanations of the above categories can be found in 3GPP TR 21.900 .		Use <u>one</u> of the following releases: 2 (GSM Phase 2) R96 (Release 1996) R97 (Release 1997) R98 (Release 1998) R99 (Release 1999) Rel-4 (Release 4) Rel-5 (Release 5) Rel-6 (Release 6)

Reason for change:	⌘ In the current GBA_U description, the location (whether in the UICC or in the ME) of the storage of Ks_ext is ffs. The storage of Ks_ext in the UICC provides a higher level of security and extends Ks_ext key life time. So, the location of Ks_ext has to be the UICC for GBA_U
Summary of change:	⌘ In GBA_U, Ks_ext is stored in the UICC
Consequences if not approved:	⌘ The location of Ks_ext will remain not specified for GBA_U.

Clauses affected:	⌘ 5								
Other specs affected:	<table border="1" style="display: inline-table; border-collapse: collapse;"> <tr> <td style="width: 20px; text-align: center;">Y</td> <td style="width: 20px; text-align: center;">N</td> </tr> <tr> <td style="width: 20px; height: 15px;"></td> <td style="width: 20px; height: 15px;"></td> </tr> <tr> <td style="width: 20px; height: 15px;"></td> <td style="width: 20px; height: 15px;"></td> </tr> </table> Other core specifications ⌘ Test specifications O&M Specifications	Y	N						
Y	N								
Other comments:	⌘								

3 Definitions and abbreviations

3.1 Definitions

For the purposes of the present document, the following terms and definitions apply:

Bootstrapping Server Function: BSF is hosted in a network element under the control of an MNO.

Editor's note: Definition to be completed.

ME-based GBA: in GBA_ME, all GBA-specific functions are carried out in the ME. The UICC is GBA-unaware. If the term GBA is used in this document without any further qualification then always GBA_ME is meant, see clause 4 of this specification.

UICC-based GBA: this is a GBA with UICC-based enhancement. In GBA_U, the GBA-specific functions are split between ME and UICC, see clause 5 of this specification.

Network Application Function: NAF is hosted in a network element under the control of an MNO.

Editor's note: Definition to be completed.

Bootstrapping Transaction Identifier:

Editor's note: Definition to be completed.

3.2 Abbreviations

For the purposes of the present document, the following abbreviations apply:

AK	Anonymity Key
AKA	Authentication and Key Agreement
B-TID	Bootstrapping Transaction Identifier
BSF	Bootstrapping Server Function
CA	Certificate Authority
FQDN	Fully Qualified Domain Name
GAA	Generic Authentication Architecture
GBA	Generic Bootstrapping Architecture
GBA_ME	ME-based GBA
GBA_U	GBA with UICC-based enhancements
HSS	Home Subscriber System
IK	Integrity Key
KDF	Key Derivation Function
Ks_int	Derived key in GBA_U which remains on UICC
Ks_ext	Derived key in GBA_U which remains on UICC
MNO	Mobile Network Operator
NAF	Network Application Function
PKI	Public Key Infrastructure

END OF CHANGE

BEGIN OF CHANGE

5 UICC-based enhancements to Generic Bootstrapping Architecture (GBA_U)

It is assumed that the UICC, BSF, and HSS involved in the procedures specified in this clause are capable of handling the GBA_U specific enhancements. The procedures specified in this clause also apply if NAF is not GBA_U aware, but, of course, in that case there are no benefits of the GBA_U specific enhancements.

5.1 Architecture and reference points for bootstrapping with UICC-based enhancements

The text from clause 4.4 of this specification applies also here, with the addition that the interface between the ME and the UICC, as specified in TS 31.102 [1] and TS 31.103 [10], needs to be enhanced with GBA_U specific commands. The requirements on these commands can be found in clause 5.2.1, details on the procedures are in clause 5.3.

5.2 Requirements and principles for bootstrapping with UICC-based enhancements

The requirements and principles from clause 4.3 also apply here with the following addition:

5.2.1 Requirements on UE

The 3G AKA keys CK and IK resulting from a run of the protocol over the Ub reference point shall not leave the UICC.

The UICC shall be able to distinguish between authentication requests for GBA_U, and authentication requests for other 3G authentication domains.

Upon an authentication request from the ME, which the UICC recognises as related to GBA_U, the UICC shall derive two keys from CK and IK. All 3G MEs are capable of such a request.

Upon request from the ME, the UICC shall be able to derive further NAF-specific keys from the derived key stored on the UICC. Only GBA_U-aware 3G MEs are capable of such a request.

Editors' Note: The location (whether in the UICC or in the ME) of the storage of Ks_ext is ffs.

5.2.2 Requirements on BSF

BSF shall support both GBA_U and GBA_ME bootstrapping procedures. The decision on running one or the other shall be based on subscription information (i.e. UICC capabilities).

The BSF shall be able to acquire the UICC capabilities related to GBA as part of the GBA user security settings received from the HSS.

5.3 Procedures for bootstrapping with UICC-based enhancements

5.3.1 Initiation of bootstrapping

The text from clause 4.5.1 of this document applies also here.

5.3.2 Bootstrapping procedure

The procedure specified in this clause differs from the procedure specified clause 4.5.2 in the local handling of keys and Authentication Vectors in the UE and the BSF. The messages exchanged over the Ub reference point are identical for both procedures.

When a UE wants to interact with a NAF, and it knows that the bootstrapping procedure is needed, it shall first perform a bootstrapping authentication (see figure 5.1). Otherwise, the UE shall perform a bootstrapping authentication only when it has received bootstrapping initiation required message or a bootstrapping renegotiation indication from the NAF, or when the lifetime of the key in UE has expired (see clause 5.3.3).

NOTE: The main steps from the specifications of the AKA protocol in TS 33.102 [2] and the HTTP digest AKA protocol in RFC 3310 [4] are repeated in figure 5.1 for the convenience of the reader. In case of any potential conflict, the specifications in TS 33.102 [2] and RFC 3310 [4] take precedence.

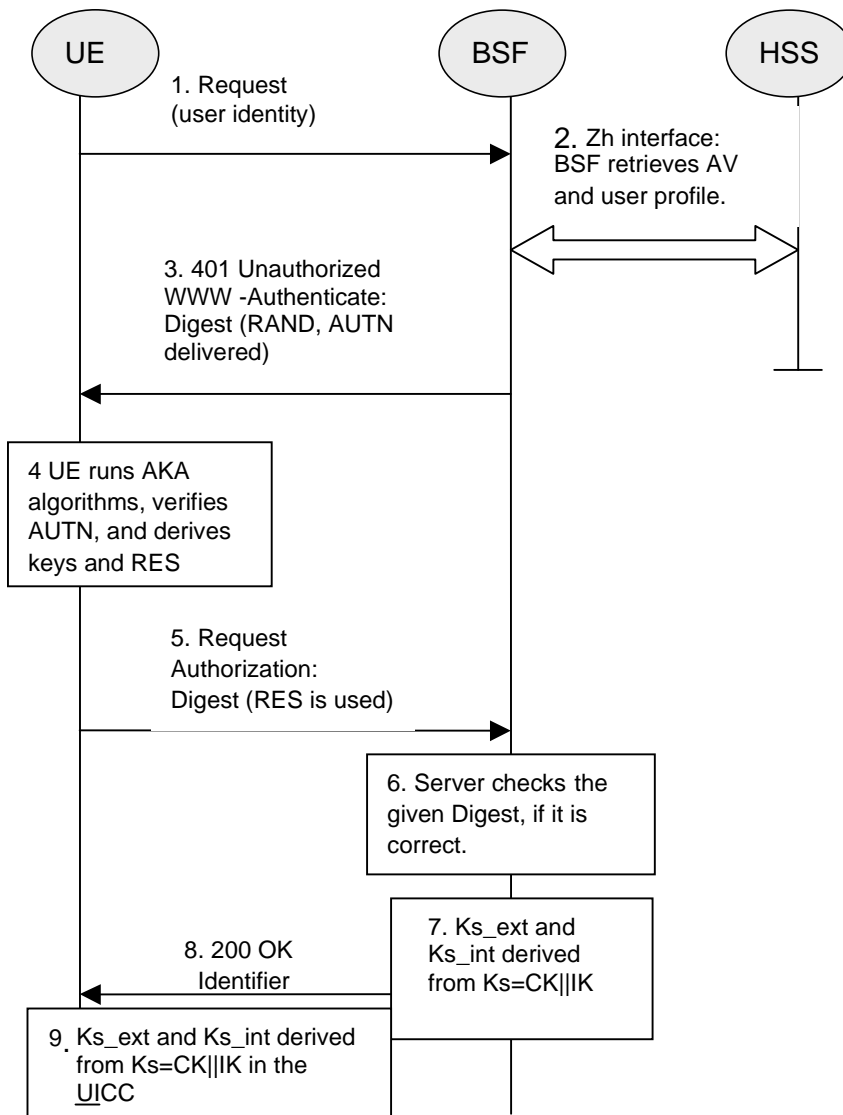

Figure 5.1: The bootstrapping procedure with UICC-based enhancements

1. The ME sends an HTTP request towards the BSF.
2. The BSF retrieves the complete set of GBA user security settings and one or a whole batch of Authentication Vectors (AV, AV = RAND||AUTN||XRES||CK||IK) over the Zh reference point from the HSS. The BSF can then decide to perform GBA_U, based on the user security settings (USSs). In this case, the BSF proceeds in the following way:
 - BSF computes $MAC^* = MAC \text{ SHA-1}(IK1)$ (where $IK = IK1 || IK2$ and * is a exclusive or as described in TS 33.102 [2])

Editor's note: The exact format of the MAC modification function is to be reviewed. The output of SHA-1 needs to be truncated to exact amount of bits needed (64 bits).

The BSF stores the XRES after flipping the least significant bit.

3. Then BSF forwards the RAND and AUTN* (where $AUTN^* = SQN \oplus AK \parallel AMF \parallel MAC^*$) to the UE in the 401 message (without the CK, IK and XRES). This is to demand the UE to authenticate itself.
4. The ME sends RAND and AUTN* to the UICC. The UICC calculates IK and MAC (by performing $MAC = MAC^* \oplus SHA-1(IK \parallel \text{RAND})$). Then the UICC checks AUTN (i.e. $SQN \oplus AK \parallel AMF \parallel MAC$) to verify that the challenge is from an authorised network; the UICC also calculates CK and RES. This will result in session keys CK and IK in both BSF and UICC.
5. The UICC then applies a suitable key derivation function h1 to Ks, which is the concatenation of CK and IK, and possibly further h1-key derivation parameters to obtain two keys, Ks_ext and Ks_int, each of length 128 bit, i.e. $h1(Ks, h1 \text{ key derivation parameters}) = Ks_ext \parallel Ks_int$ (see also figure 5.2). The UICC then transfers RES (after flipping the least significant bit) ~~and Ks_ext to the ME~~ and stores Ks_int/~~ks~~Ks_ext on the UICC.

Editors' Note: The definition of the h1 is left to ETSI SAGE and is to be included in the Annex B of the present specification.

~~Editors' Note: The location (whether in the UICC or in the ME) of the storage of Ks_ext is ffs.~~

- ~~56.~~The ME sends another HTTP request, containing the Digest AKA response (calculated using RES), to the BSF.
- ~~67.~~ The BSF authenticates the UE by verifying the Digest AKA response.
- ~~78.~~ The BSF generates the key Ks by concatenating CK and IK. Then the BSF applies the key derivation function h1 to Ks and possibly further h1-key derivation parameters to obtain two keys, Ks_ext and Ks_int, in the same way as the UICC did in step 5. The B-TID value shall be also generated in format of NAI by taking the base64 encoded [12] RAND value from step 3, and the BSF server name, i.e. $base64encode(RAND)@BSF_servers_domain_name$.
- ~~89.~~ The BSF shall send a 200 OK message, including the B-TID, to the UE to indicate the success of the authentication. In addition, in the 200 OK message, the BSF shall supply the lifetime of the keys Ks_ext and Ks_int, The lifetimes of the keys Ks_ext and Ks_int shall be the same.
- ~~940.~~ The BSF shall use the keys Ks_ext and Ks_int to derive the NAF-specific keys Ks_ext_NAF and Ks_int_NAF, if requested by a NAF over the Zn reference point. Ks_ext_NAF and Ks_int_NAF are used for securing the Ua reference point. The ~~UE-UICC~~ shall use the key Ks_ext to derive the NAF-specific key Ks_ext_NAF, if applicable. The UICC shall use the key Ks_int to derive the NAF-specific key Ks_int_NAF, if applicable.

Ks_ext_NAF is computed in the UICC as $Ks_ext_NAF = h2(Ks_ext, h2\text{-key derivation parameters})$, and Ks_int_NAF is computed in the UICC as $Ks_int_NAF = h2(Ks_int, h2\text{-key derivation parameters})$, where h2 is a suitable key derivation function, and the h2-key derivation parameters include the user's IMPI, the NAF_Id and RAND. The NAF_Id consists of the full DNS name of the NAF.

Editors' Note: The definition of the h2 is left to ETSI SAGE and is to be included in the Annex B of the present specification.

NOTE: The NOTE 2 of clause 4.5.2 also applies here.

~~The ME,~~ The UICC and the BSF store the keys Ks_ext and Ks_int together with the associated B-TID for further use, until the lifetime of Ks_ext and Ks_int has expired, or until the keys Ks_ext and Ks_int are updated.

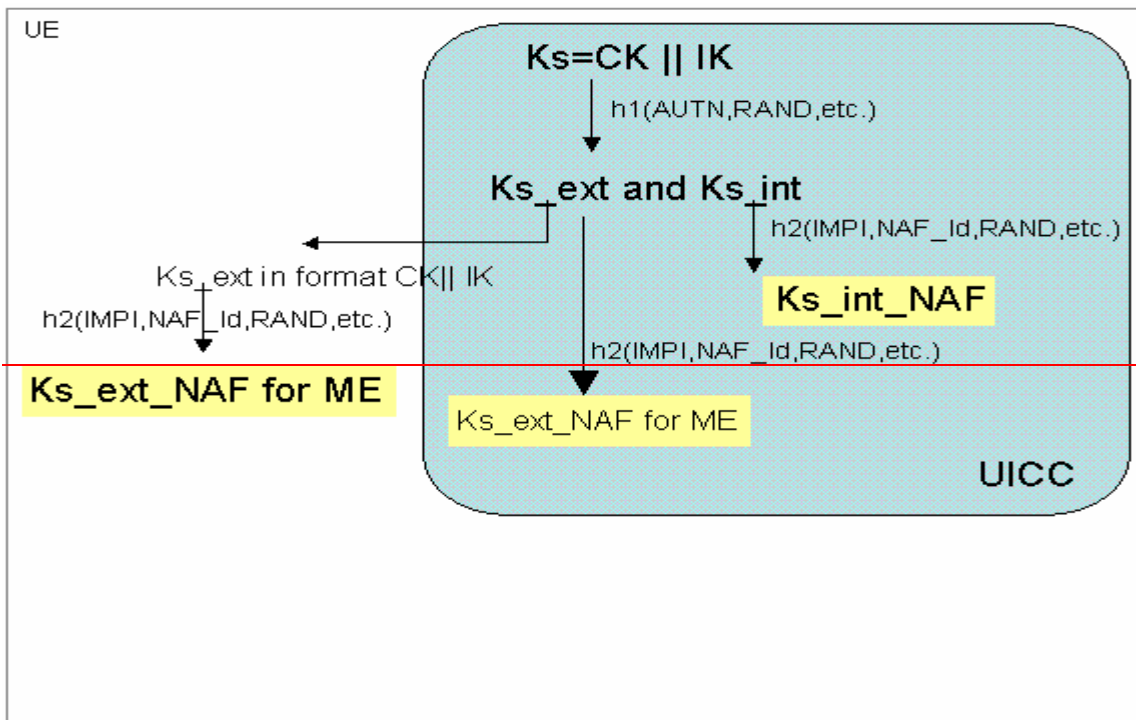

Figure 5.2: Key derivation for GBA-aware UICC when GBA-run was triggered

5.3.3 Procedures using bootstrapped Security Association

Before communication between the UE and the NAF can start, the UE and the NAF first have to agree whether to use shared keys obtained by means of the GBA. If the UE does not know whether to use GBA with this NAF, it uses the Initiation of Bootstrapping procedure described in clause 5.3.1.

Once the UE and the NAF have established that they want to use GBA then every time the UE wants to interact with a NAF the following steps are executed as depicted in figure 5.3.

Next, the UE and the NAF have to agree, which type of keys to use, Ks_ext_NAF or Ks_int_NAF , or both. The default is the use of Ks_ext_NAF only. This use is also supported by MEs and NAFs, which are GBA_U unaware. If Ks_int_NAF , or both Ks_ext and Ks_int are to be used, this use has to be agreed between UE and NAF prior to the

execution of the procedure described in the remainder of this clause 5.3.3. Any such agreement overrules the default use of the keys. How this agreement is reached is application-specific and is not within the scope of this document.

NOTE 1: This agreement may be mandated by the specification, which defines the Ua reference point between UE and NAF, e.g. TS 33.246 for the use of GBA in MBMS, or negotiated by the NAF and the UE over the Ua reference point, or reached by configuration.

Editors' Note: The support of ~~unaware~~-GBA_U-~~unaware~~ MEs, which are GBA_ME aware only is FFS.

In general, UE and NAF will not yet share the key(s) required to protect the Ua reference point. If they do not, the UE proceeds as follows:

- if Ks_ext_NAF is required and a key Ks_ext for the selected UICC application is available in the ~~UE~~UICC, the ~~UE~~ME requests the UICC to derive the key Ks_ext_NAF from Ks_ext, as specified in clause 5.3.2;
- if Ks_int_NAF is required and a key Ks_int for the selected UICC application is available in the UICC, the ME requests the UICC to derive the key Ks_int_NAF from Ks_int, as specified in clause 5.3.2;

NOTE 2: If it is not desired by the UE to use the same Ks_ext/int for the selected UICC application to derive more than one Ks_ext/int_NAF then the UE should first agree on new keys Ks_ext and Ks_int with the BSF over the Ub reference point, as specified in clause 5.3.2, and then proceeds to derive Ks_ext_NAF or Ks_int_NAF, or both, as required.

- if Ks_ext and Ks_int for the selected UICC application are not available in the UE, the UE first agrees on new keys Ks_ext and Ks_int with the BSF over the Ub reference point, as specified in clause 5.3.2, and then proceeds to derive Ks_ext_NAF or Ks_int_NAF, or both, as required;
- if the NAF shares a key with the UE, but the NAF requires an update of that key, it shall send a suitable bootstrapping renegotiation request to the UE and terminate the protocol used over Ua reference point. The form of this indication depends on the particular protocol used over Ua reference point. If the UE receives a bootstrapping renegotiation request, it starts a run of the protocol over Ub, as specified in clause 5.3.2, in order to obtain new keys.

NOTE 3: If the shared keys between UE and NAF become invalid, the NAF can set deletion conditions to the corresponding security association for subsequent removal.

NOTE 4: If it is not desired by the NAF to use the same Ks to derive more than one Ks_int/ext_NAF then the NAF should always reply to the first request sent by a UE by sending a key update request to the UE.

UE and NAF can now start the communication over Ua reference point using the keys Ks_ext_NAF or Ks_int_NAF, or both, as required. They proceed as follows:

- The UE supplies the B-TID to the NAF, as specified in clause 5.3.2, to allow the NAF to retrieve the corresponding keys from the BSF

NOTE 5: To allow for consistent key derivation in BSF and UE, both have to use the same FQDN for derivation (cf. NOTE 2 of clause 4.5.2). For each protocol used over Ua it shall be specified if only cases (1) and (2) of NOTE 2 of clause 4.5.2 are allowed for the NAF or if the protocol used over Ua shall transfer also the FQDN used for key derivation by UE to NAF.

NOTE 6: The UE may adapt the keys Ks_ext_NAF or Ks_int_NAF to the specific needs of the Ua reference point. This adaptation is outside the scope of this specification.

- when the UE is powered down, or when the UICC is removed, any GBA_U keys shall be deleted from storage in the ME. There is no need to delete keys Ks_int and Ks_int_NAF from storage in the UICC;

NOTE 7: After each run of the protocol over the Ub reference point, new keys Ks_ext and Ks_int, associated with a new B-TID, are derived in the UE according to clause 5.3.2, so that it can never happen, that keys Ks_ext and Ks_int with different B-TIDs simultaneously exist in the UE.

- When new keys Ks_ext and Ks_int are agreed over the Ub reference point and new NAF-specific keys need to be derived for one NAF_Id, then both, Ks_ext_NAF and Ks_int_NAF (if present), shall be updated for this NAF_Id, but further keys Ks_ext_NAF or Ks_int_NAF relating to other NAF_Ids, which may be stored on the UE, shall not be affected;

NOTE 8: This rule ensures that the keys Ks_ext_NAF and Ks_int_NAF are always in synch at the UE and the NAF.

NAF now starts communication over the Zn reference point with the BSF.

- The NAF requests from the BSF the keys corresponding to the B-TID, which was supplied by the UE to the NAF over the Ua reference point. If the NAF is GBA_U aware it indicates this by including a corresponding flag in the request. If the NAF has several FQDNs, which may be used in conjunction with this specification, then the NAF shall transfer in the request over Zn the same FQDN, which was used over Ua (see note above on key derivation in this clause).
- The NAF may also request application-specific user security settings for the applications, which the request received over Ua from UE may access;
- With the keys request over the Zn reference point, the NAF shall supply NAF's public hostname that UE has used to access NAF to BSF, and BSF shall be able to verify that NAF is authorized to use that hostname.
- The BSF derives the keys Ks_ext_NAF, and Ks_int_NAF (if additionally required), as specified in clause 5.3.2. If the NAF indicated in its request that it is GBA_U aware, the BSF supplies to NAF both keys, Ks_ext_NAF, and Ks_int_NAF, otherwise the BSF supplies only Ks_ext_NAF. In addition, the BSF supplies the lifetime time of these keys. If the key identified by the B-TID supplied by the NAF is not available at the BSF, the BSF shall indicate this in the reply to the NAF. The NAF then indicates a bootstrapping renegotiation request (See figure 4.5) to the UE;

NOTE: The NAF may adapt the keys Ks_ext_NAF and Ks_int_NAF to the specific needs of the Ua reference point in the same way as the UE did. This adaptation is outside the scope of this specification.

- The BSF may also send the private user identity (IMPI) and requested user security settings to NAF according to the BSF's policy.

The NAF now continues with the protocol used over the Ua reference point with the UE.

Once the run of the protocol used over Ua reference point is completed the purpose of bootstrapping is fulfilled as it enabled the UE and NAF to use Ua reference point in a secure way.

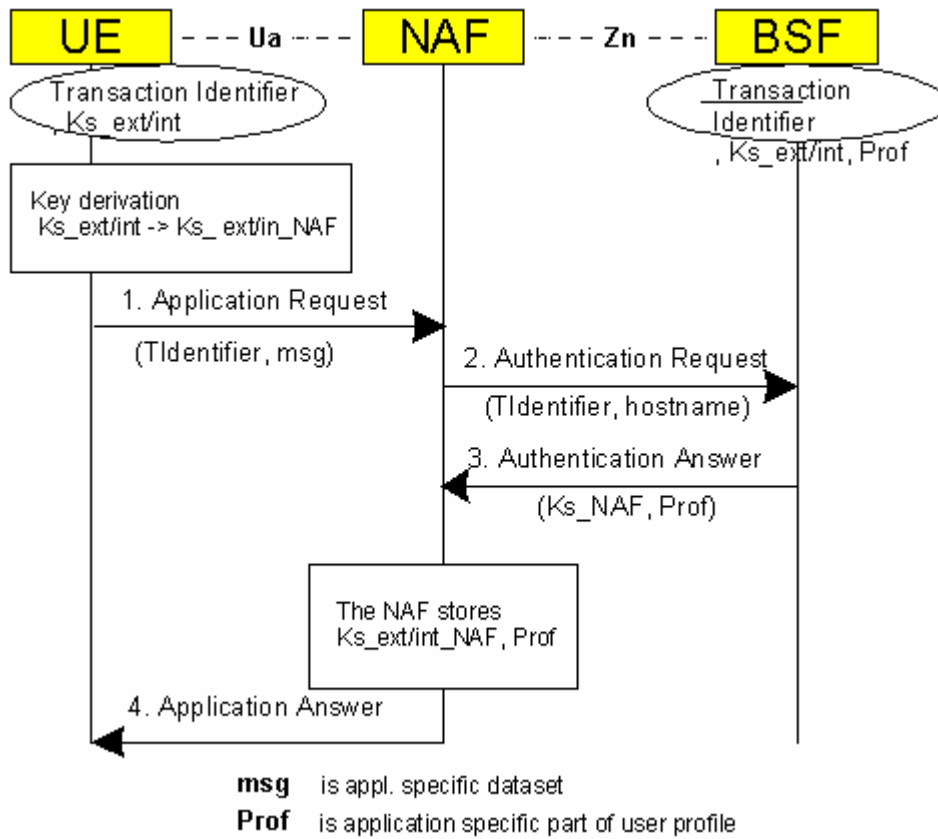

Figure 5.3: The bootstrapping usage procedure with UICC-based enhancements

5.3.4 Procedure related to service discovery

The text from clause 4.5.4 of this document applies also here.