

CR-Form-v7

CHANGE REQUEST

33.234 CR CRNum # rev - # Current version: **6.0.0**

For **HELP** on using this form, see bottom of this page or look at the pop-up text over the # symbols.

Proposed change affects: UICC apps ME Radio Access Network Core Network

Title:	# Identity request procedure clarification		
Source:	# Ericsson		
Work item code:	# WLAN	Date:	# 03/05/2004
Category:	# F	Release:	# Rel-6
	Use <u>one</u> of the following categories:		Use <u>one</u> of the following releases:
	F (correction)		2 (GSM Phase 2)
	A (corresponds to a correction in an earlier release)		R96 (Release 1996)
	B (addition of feature),		R97 (Release 1997)
	C (functional modification of feature)		R98 (Release 1998)
	D (editorial modification)		R99 (Release 1999)
	Detailed explanations of the above categories can be found in 3GPP TR 21.900 .		Rel-4 (Release 4)
			Rel-5 (Release 5)
			Rel-6 (Release 6)

Reason for change:	# The EAP SIM and EAP AKA internet drafts establish that the user identity has to be obtained by the EAP server (in 3GPP, the AAA server) by means of the EAP SIM/AKA specific method, even if the identity was successfully obtained in the EAP response identity message. This CR adds this technical detail to TS 33.234
Summary of change:	# EAP SIM and EAP AKA procedures will be updated with the EAP SIM and EAP AKA specific methods for obtaining user's identity
Consequences if not approved:	# TS 33.234 not aligned with current IETF drafts (EAP SIM and EAP AKA)

Clauses affected:	# 6.1.1 and 6..1.2		
Other specs affected:	#	Y	N
	#	X	<input type="checkbox"/>
	#	<input type="checkbox"/>	X
	#	<input type="checkbox"/>	X
Other comments:	#		

*** BEGIN SET OF CHANGES ***

6.1.1.1 EAP/AKA Procedure

The EAP-AKA authentication mechanism is specified in ref. [4]. The present section describes how this mechanism is used in the WLAN-3GPP interworking scenario.

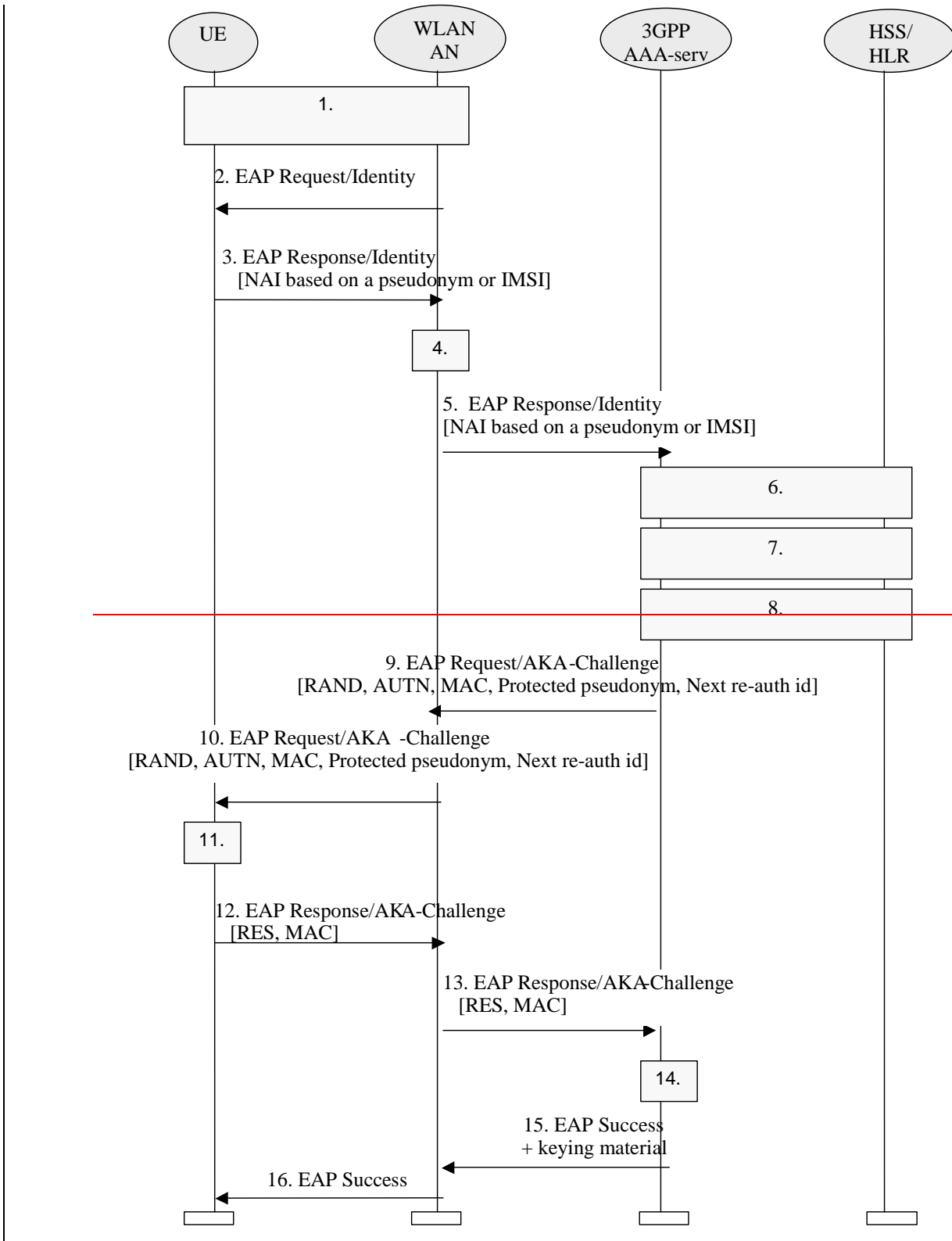

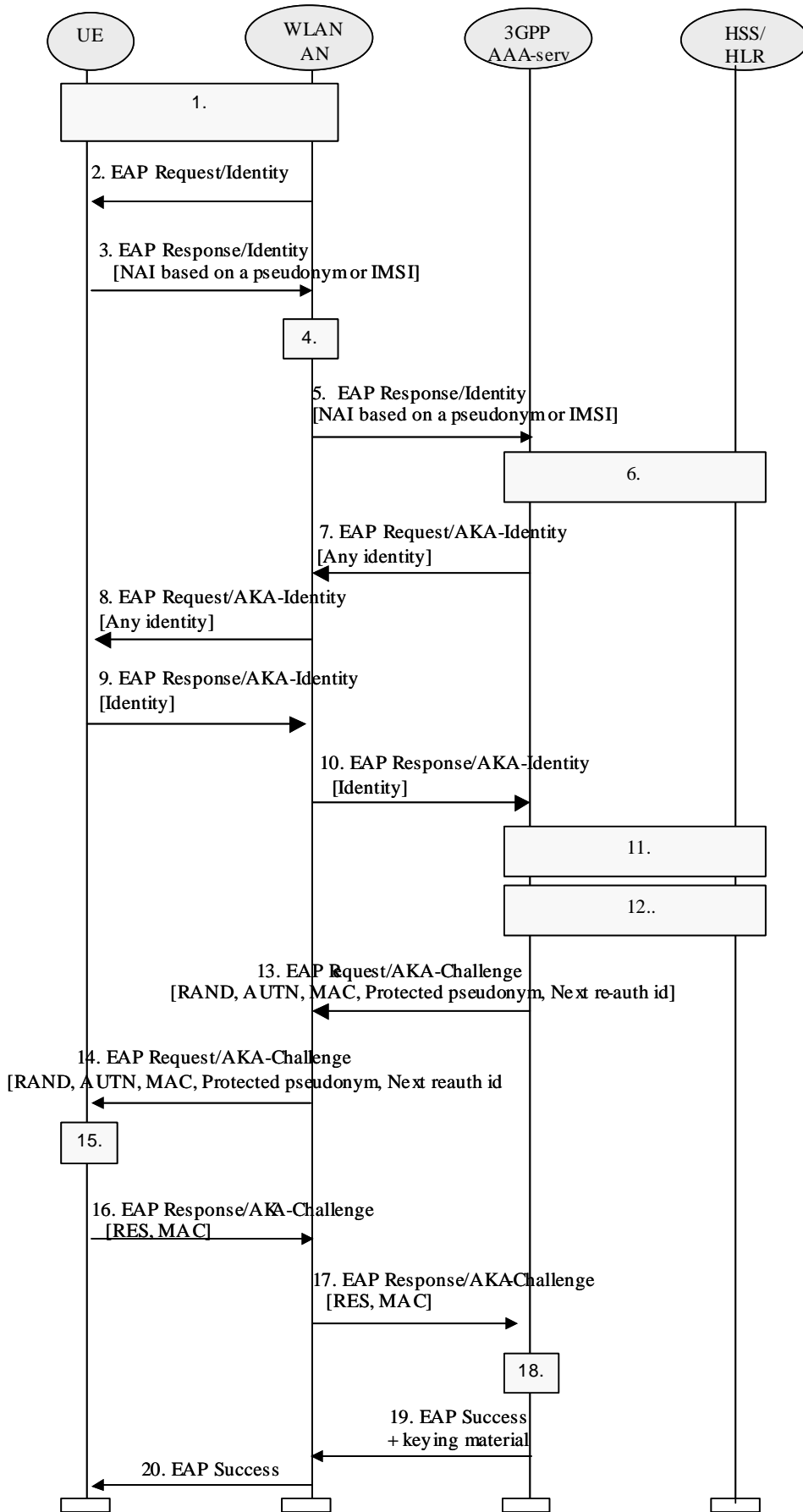

Figure 4: Authentication based on EAP AKA scheme

1. A connection is established between the WLAN-UE and the WLAN-AN, using a Wireless LAN technology specific procedure (out of scope for this specification).
2. The WLAN-AN sends an EAP Request/Identity to the WLAN-UE.

EAP packets are transported over the Wireless LAN interface encapsulated within a Wireless LAN technology specific protocol.

3. The WLAN-UE sends an EAP Response/Identity message. The WLAN-UE sends its identity complying with Network Access Identifier (NAI) format specified in RFC 2486. NAI contains either a temporary identifier (pseudonym) allocated to the WLAN-UE in previous authentication or, in the case of first authentication, the IMSI.

NOTE 1: Generating an identity conforming to NAI format from IMSI is defined in EAP/AKA [4].

4. The message is routed towards the proper 3GPP AAA Server based on the realm part of the NAI. The routing path may include one or several AAA proxies (not shown in the figure).

NOTE 2: Diameter referral can also be applied to find the AAA server.

5. The 3GPP AAA server receives the EAP Response/Identity packet that contains the subscriber identity.
6. 3GPP AAA Server identifies the subscriber as a candidate for authentication with EAP-AKA, based on the received identity. The 3GPP AAA Server then checks that it has an unused authentication vector available for that subscriber. If not, a set of new authentication vectors is retrieved from HSS/HLR. A mapping from the temporary identifier to the IMSI may be required.

NOTE 3: It could also be the case that the 3GPP AAA Server first obtains an unused authentication vector for the subscriber and, based on the type of authenticator vector received (i.e. if a UMTS authentication vector is received), it regards the subscriber as a candidate for authentication with EAP-AKA.

7. The 3GPP AAA server requests again the user identity, using the EAP Request/AKA Identity message. This identity request is performed as the intermediate nodes may have changed or replaced the user identity received in the EAP Response Identity message, as specified in ref. [4]. However, this new request of the user identity can be omitted by the home operator if there exist the certainty that the user identity could not be changed or modifies by any means in the EAP Response Identity message.

8. The WLAN AN forwards the EAP Request/AKA Identity message to the WLAN UE

9. The WLAN UE responds with the same identity it used in the EAP Response Identity message

10. The WLAN UE forwards the EAP Response/AKA Identity to the 3GPP AAA server. The identity received in this message will be used by the 3GPP AAA server in the rest of the authentication process. If an inconsistency is found between the identities received in the two messages (EAP Response Identity and EAP Response/AKA Identity) so that the user profile and authentication vectors previously retrieved from HSS/HLR are not valid, these data shall be requested again to HSS/HLR (steps 6, 7 and 8 will be repeated before continuing with step 11).

NOTE 4: In order to optimise performance, the identity re-request process (the latter four steps) should be performed when the 3GPP AAA server has enough information to identify the user as an EAP-AKA user, and before user profile and authentication vectors retrieval, although protocol design in Wx interface may not allow to perform these four steps until the whole user profile has been downloaded to the 3GPP AAA server.

11. 3GPP AAA server checks that it has the WLAN access profile of the subscriber available. If not, the profile is retrieved from HSS. 3GPP AAA Server verifies that the subscriber is authorized to use the WLAN service.

Although this step is presented after step 6 in this example, it could be performed at some other point, however before step 14. (This will be specified as part of the Wx interface.)

~~8~~12. New keying material is derived from IK and CK., cf. [4]. This keying material is required by EAP-AKA, and some extra keying material may also be generated for WLAN technology specific confidentiality and/or integrity protection.

A new pseudonym may be chosen and protected (i.e. encrypted and integrity protected) using EAP-AKA generated keying material.

~~9~~13. 3GPP AAA Server sends RAND, AUTN, a message authentication code (MAC) and two user identities (if they are generated): protected pseudonym and/or re-authentication id to WLAN-AN in EAP Request/AKA-Challenge message. The sending of the re-authentication id depends on 3GPP operator's policies on whether to allow fast re-authentication processes or not. It implies that, at any time, the AAA server decides (based on policies set by the operator) to include the re-authentication id or not, thus allowing or disallowing the triggering of the fast re-authentication process.

~~10~~14. The WLAN-AN sends the EAP Request/AKA-Challenge message to the WLAN-UE.

~~11~~15. The WLAN-UE runs UMTS algorithm on the USIM. The USIM verifies that AUTN is correct and hereby authenticates the network. If AUTN is incorrect, the terminal rejects the authentication (not shown in this example). If the sequence number is out of synch, terminal initiates a synchronization procedure, c.f. [4]. If AUTN is correct, the USIM computes RES, IK and CK.

The WLAN UE derives required additional new keying material from the new computed IK and CK from the USIM, checks the received MAC with the new derived keying material.

If a protected pseudonym was received, then the WLAN-UE stores the pseudonym for future authentications.

~~12~~16. The WLAN UE calculates a new MAC value covering the EAP message with the new keying material. WLAN-UE sends EAP Response/AKA-Challenge containing calculated RES and the new calculated MAC value to WLAN-AN.

~~13~~17. WLAN-AN sends the EAP Response/AKA-Challenge packet to 3GPP AAA Server

~~14~~18. 3GPP AAA Server checks the received MAC and compares XRES to the received RES.

~~15~~19. If all checks in step ~~14~~18 are successful, then 3GPP AAA Server sends the EAP Success message to WLAN-AN. If some extra keying material was generated for WLAN technology specific confidentiality and/or integrity protection then the 3GPP AAA Server includes this keying material in the underlying AAA protocol message (i.e. not at EAP level). The WLAN-AN stores the keying material to be used in communication with the authenticated WLAN-UE.

~~16~~20. WLAN-AN informs the WLAN-UE about the successful authentication with the EAP Success message. Now the EAP AKA exchange has been successfully completed, and the WLAN-UE and the WLAN-AN share keying material derived during that exchange.

*** END SET OF CHANGES ***

*** BEGIN SET OF CHANGES ***

6.1.2.1 EAP SIM procedure

The EAP-SIM authentication mechanism is specified in ref. [5]. The present section describes how this mechanism is used in the WLAN-3GPP interworking scenario.

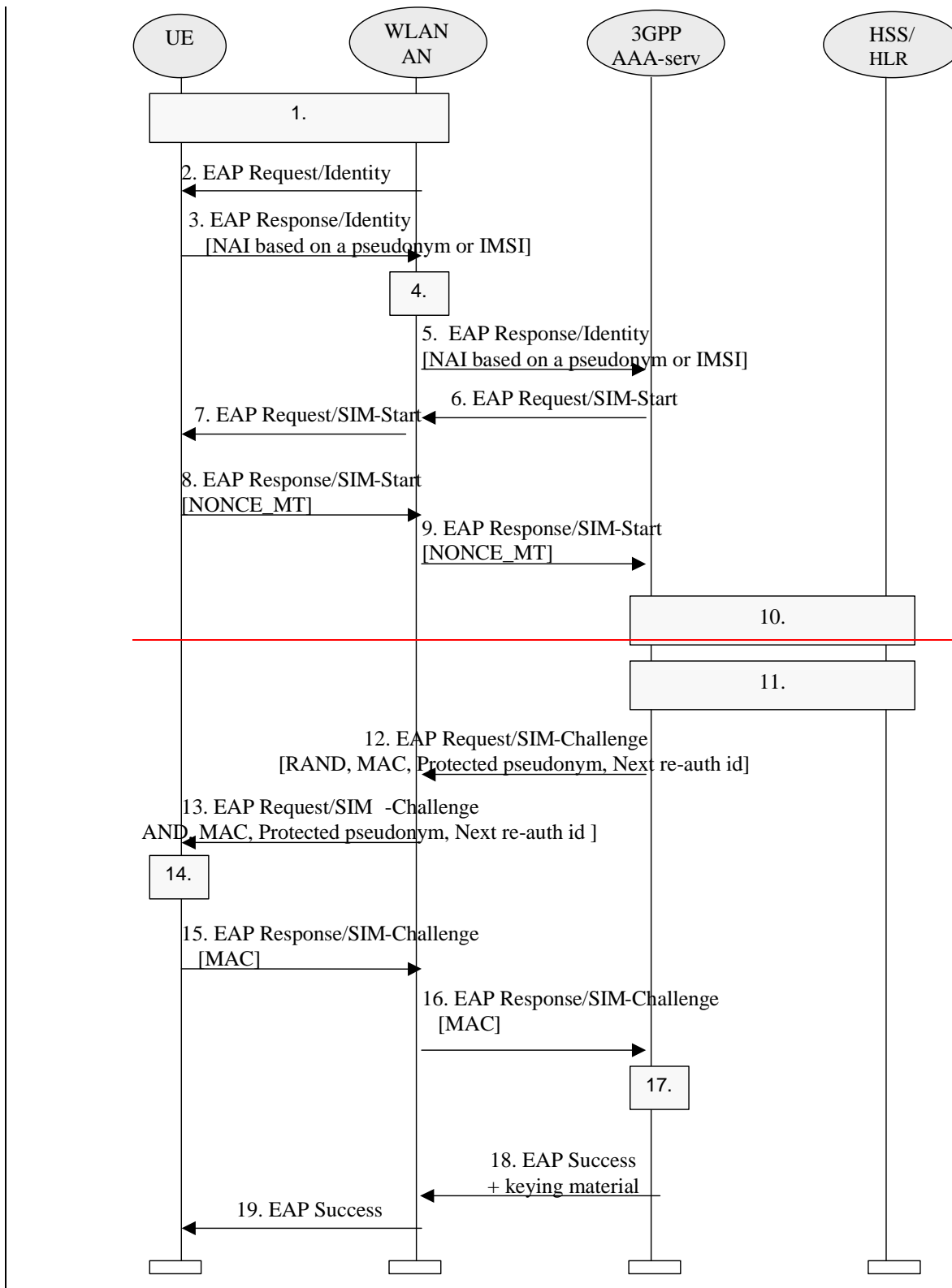

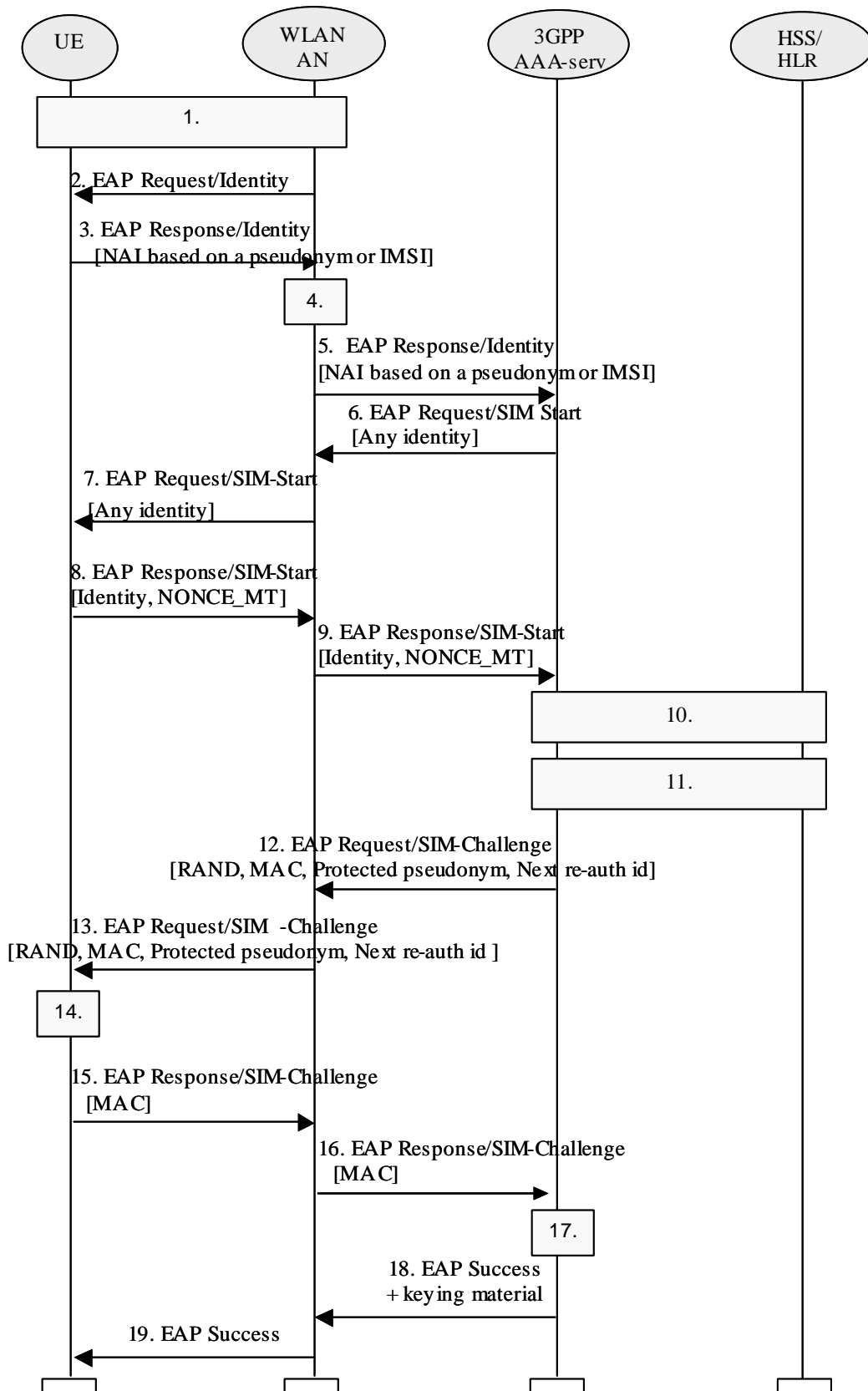

Figure 5: Authentication based on EAP SIM scheme

1. A connection is established between the WLAN-UE and the WLAN-AN, using a Wireless LAN technology specific procedure (out of scope for this specification).
2. The WLA-AN sends an EAP Request/Identity to the WLAN-UE.

EAP packets are transported over the Wireless LAN interface encapsulated within a Wireless LAN technology specific protocol.

3. The WLAN-UE sends an EAP Response/Identity message. The WLAN-UE sends its identity complying with the Network Access Identifier (NAI) format specified in RFC 2486. NAI contains either a temporary identifier (pseudonym) allocated to WLAN-UE in previous authentication or, in the case of first authentication, the IMSI.

NOTE 1: Generating an identity conforming to NAI format from IMSI is defined in EAP/SIM.

4. The message is routed towards the proper 3GPP AAA Server based on the realm part of the NAI. The routing path may include one or several AAA proxies (not shown in the figure).

NOTE 2: Diameter referral can also be applied to find the AAA server.

5. The 3GPP AAA server receives the EAP Response/Identity packet that contains the subscriber identity.
6. The 3GPP AAA Server, identifies the subscriber as a candidate for authentication with EAP-SIM, based on the received identity, and then it sends the EAP Request/SIM-Start packet to WLAN-AN. [The 3GPP AAA server requests again the user identity. This identity request is performed as the intermediate nodes may have changed or replaced the user identity received in the EAP Response Identity message, as specified in ref. \[5\]. However, this new request of the user identity can be omitted by the home operator if there exist the certainty that the user identity could not be changed or modified by any means in the EAP Response Identity message.](#)

NOTE 3: It could also be the case that the 3GPP AAA Server first obtains an authentication vector for the subscriber and, based on the type of authenticator vector received (i.e. if a GSM authentication vector is received), it regards the subscriber as a candidate for authentication with EAP-SIM.

7. WLAN-AN sends the EAP Request/SIM-Start packet to WLAN-UE
8. The WLAN-UE chooses a fresh random number NONCE_MT. The random number is used in network authentication. [The WLAN UE includes the same user identity it used in the EAP Response Identity message](#)
The WLAN-UE sends the EAP Response/SIM-Start packet, containing NONCE_MT [and the user identity](#), to WLAN-AN.
9. WLAN-AN sends the EAP Response/SIM-Start packet to 3GPP AAA Server. [The identity received in this message will be used by the 3GPP AAA server in the rest of the authentication process. If an inconsistency is found between the identities received in the two messages \(EAP Response Identity and EAP Response/SIM Start\) so that any user data retrieved previously from HSS/HLR are not valid, these data shall be requested again to HSS/HLR.](#)
10. The AAA server checks that it has available N unused authentication vectors for the subscriber. Several GSM authentication vectors are required in order to generate keying material with effective length equivalent to EAP-AKA. If N authentication vectors are not available, a set of authentication vectors is retrieved from HSS/HLR. A mapping from the temporary identifier to the IMSI may be required.

Although this step is presented after step 9 in this examples, it could be performed at some other point, for example after step 5, however before step 12. (This will be specified as part of the Wx interface.)

11. The AAA server checks that it has the WLAN access profile of the subscriber available. If not, the profile is retrieved from HSS/HLR. 3GPP AAA Server verifies that the subscriber is authorized to use the WLAN service.

Although this step is presented after step 10 in this example, it could performed at some other point, however before step 18. (This will be the specified as part of the Wx interface).

12. New keying material is derived from NONCE_MT and N Kc keys. This keying material is required by EAP-SIM, and some extra keying material may also be generated for WLAN technology specific confidentiality and/or integrity protection.

A new pseudonym and/or a re-authentication identity may be chosen and protected (i.e. encrypted and integrity protected) using EAP-SIM generated keying material.

A message authentication code (MAC) is calculated over the EAP message using an EAP-SIM derived key. This MAC is used as a network authentication value.

3GPP AAA Server sends RAND, MAC, protected pseudonym and re-authentication identity (the two latter in case they were generated) to WLAN-AN in EAP Request/SIM-Challenge message. The sending of the re-authentication id depends on 3GPP operator's policies on whether to allow fast re-authentication processes or not. It implies that, at any time, the AAA server decides (based on policies set by the operator) to include the re-authentication id or not, thus allowing or disallowing the triggering of the fast re-authentication process.

13. The WLAN sends the EAP Request/SIM-Challenge message to the WLAN-UE.

14. WLAN-UE runs N times the GSM A3/A8 algorithms in the SIM, once for each received RAND.

This computing gives N SRES and Kc values.

The WLAN-UE derives additional keying material from N Kc keys and NONCE_MT.

The WLAN-UE calculates its copy of the network authentication MAC with the newly derived keying material and checks that it is equal with the received MAC. If the MAC is incorrect, the network authentication has failed and the WLAN-UE cancels the authentication (not shown in this example). The WLAN-UE continues the authentication exchange only if the MAC is correct.

The WLAN-UE calculates a new MAC with the new keying material covering the EAP message concatenated to the N SRES responses.

If a protected pseudonym was received, then the WLAN-UE stores the pseudonym for future authentications.

15. WLAN-UE sends EAP Response/SIM-Challenge containing calculated MAC to WLAN-AN.

16. WLAN-AN sends the EAP Response/SIM-Challenge packet to 3GPP AAA Server.

17. 3GPP AAA Server compares its copy of the response MAC with the received MAC.

18. If the comparison in step 17 is successful, then 3GPP AAA Server sends the EAP Success message to WLAN-AN. If some extra keying material was generated for WLAN technology specific confidentiality and/or integrity protection, then the 3GPP AAA Server includes this derived keying material in the underlying AAA protocol message. (i.e. not at EAP level). The WLAN-AN stores the keying material to be used in communication with the authenticated WLAN-UE.

19. WLAN-AN informs the WLAN-UE about the successful authentication with the EAP Success message. Now the EAP SIM exchange has been successfully completed, and the WLAN-UE and the WLAN_AN may share keying material derived during that exchange.

NOTE 4: The derivation of the value of N is for further study.

***** END SET OF CHANGES *****