

Title: [DRAFT] Stage 3 level specification directions for support for subscriber certificate work item
Response to: N/A
Release: Rel-6
Work Item: Support for subscriber certificates (SEC1-SC)

Source: SA3
To: CN1, CN4
Cc: -

Contact Person:

Name: Pekka Laitinen
Tel. Number: +358 7 180 37438
E-mail Address: pekka.laitinen@nokia.com

Attachments: S3-030340,
Draft TS for support for subscriber certificates

1. Overall Description:

SA3 is currently working on “support for subscriber certificate” work item and has been developing specification for new protocols A, B, C, and D described in the attached draft TS. The revision marks in corresponding sections develop each protocol in stage 3 developments as below:

S3-030341	Section 4.3.1.1 (protocol A)
S3-030357	Annex B (protocol B)
S3-030342	Section 4.3.1.2 (protocol C)
S3-030343	Section 4.3.2.1 (protocol D)

Concern was raised during the discussion, on whether CN1 and CN4 have interests to develop these stage 3 specification work of protocols A, B, C, and D, or whether SA3 should be continuing in the TS. So CN1 and CN4 are kindly asked to review these sections and give their feedback on the interest of taking over the further development.

To proceed on the specification works of Protocol C and D, the attached contribution (S3-030340) points out three alternatives in section 4.1.1 (The pseudo CRs referred in S3-030340 are listed above):

1. Make a new separate application logic stage 3 specification for the BSF-HSS interface C and the NAF-BSF interface D. However, this is unpractical because the size of the new specification will be only 3-5 pages.
2. Try to include the detailed description of our C and D interfaces as annexes to the specification [TS 29.228]. Unfortunately this breaks the clear scope of the existing specification [TS 29.228]. The existing specification [TS 29.228] is totally IMS specific, and therefore it may be hard to get totally different kind of material accepted in it.
3. Include the detailed procedural descriptions to corresponding interface chapters in our current draft TS.

SA3 kindly ask CN4 to recommend a way to proceed.

2. Actions:

To CN1 group.

ACTION: SA3 kindly ask CN1 to review the attached draft TS on protocol A and B sections; and comment on interests of taking over the stage 3 specification work.

To CN4 group.

ACTION: SA kindly ask CN4 to recommend a way to proceed from the 3 approaches by reviewing the attached contribution (S3-030340) and the draft TS on protocol C and D section.

3. Date of Next TSG-S3 Meetings:

SA3 Ad-Hoc	03 – 04 Sep 2003	Europe (TBC)
SA3 #30	06 - 10 Oct 2003	Europe
SA3 #31	18 – 21 Nov 2003	London

Source: Nokia

Title: 3GPP Specifications upgrading for Bootstrapping and Subscriber Certificate

Document for: Information

Agenda Item: (7.9) Support for subscriber certificates

Table of Content:

1. INTRODUCTION.....	2
2. TERMINOLOGY	2
3. OPEN ISSUES THAT HAVE EFFECTS TO THE FOLLOWING UPGRADINGS	2
4. UPGRADES TO 3GPP TS.....	3
4.1 NEW DRAFT TS FOR BOOTSTRAPPING AND SUBSCRIBER CERTIFICATES (SA3)	3
4.1.1 Stage 3 description for protocols in C and D interfaces.....	3
4.1.2 Subscriber Certificate Profile	3
4.2 TS 29.229 CX AND DX INTERFACE BASED ON DIAMETER PROTOCOL (CN4).....	4
4.2.1 6.1.7&6.1.8 Multimedia-Auth-Request/Answer (MAR/MAA) command.....	4
4.2.2 “6.3 AVPs” chapter.....	4
4.3 TS 29.228 IMS CX AND DX INTERFACES (CN4)	4
4.3.1 Annex E.....	4
4.4 TS 23.008 ORGANIZATION OF SUBSCRIBER DATA (CN4).....	4
4.4.1 3.6 Data related to Core Network services Authorization.....	4
4.4.2 5.3 IP Multimedia Service Data Storage	4
5. POSSIBLE UPGRADES TO IETF DOCUMENTS	5
6. REFERENCES.....	5

1. INTRODUCTION

This document summarises the current understanding about the possible updates needed in the 3GPP specifications for implementation of the Bootstrapping and Subscriber Certificate procedures in their C and D interfaces.

The specifications to be upgraded belong to 3GPP SA3 and CN4.

The general Bootstrapping and Subscriber Certificate procedures are currently described in a 3GPP draft TS [S3-030317].

2. TERMINOLOGY

A interface	UE – BSF
B interface	NAF – BSF
BS	Bootstrapping
BSF	Bootstrapping Server Functionality (a network element)
C interface	BSF – HSS
D interface	NAF – BSF
IANA	Internet Assigned Numbers Authority
IMPI	IP Multimedia Private Identity
IMPU	IP Multimedia Public Identity
ISIM	IMS SIM
MAA	Multimedia-Auth-Answer
MAR	Multimedia-Auth-Request
NAF	Network Application Function (a network element)
SubCert	Subscriber Certificate

3. OPEN ISSUES THAT HAVE EFFECTS TO THE FOLLOWING UPGRADINGS

The solutions for the following open issues have effects to the summary below:

- The indication method to the HSS that the Cx-like interfaces application logic is not IMS MM, but bootstrapping.
- The down loading of AVP containing Subscriber Certificate Profile (and possible other similar future application profiles) in the C and D interfaces.

4. UPGRADES TO 3GPP TS

4.1 New draft TS for bootstrapping and subscriber certificates (SA3)

4.1.1 Stage 3 description for protocols in C and D interfaces

It is planned by SA3 that the Bootstrapping C interface and the NAF-BSF D interface are based on Diameter implementation of the 3GPP IMS MM application Cx interface.

In the IMS MM case the Cx interface Diameter messages are defined in [TS 29.229]. The IMS MM application logics in S-CSCF and HSS are described in separate implementation-independent specification [TS 29.228].

The existing Diameter implementation specification [TS 29.229] is also suitable for us possibly with small additional informative reference to our TS. But the application logic specification [TS 29.228] is entirely IMS specific. For specification of detailed application logic and messages for BSF-HSS and BSF-NAF Diameter applications we have three alternatives:

1. Make a new separate application logic stage 3 specification for the BSF-HSS interface C and the NAF-BSF interface D. However, this is unpractical because the size of the new specification will be only 3-5 pages.
2. Try to include the detailed description of our C and D interfaces as annexes to the specification [TS 29.228]. Unfortunately this breaks the clear scope of the existing specification [TS 29.228]. The existing specification [TS 29.228] is totally IMS specific, and therefore it may be hard to get totally different kind of material accepted in it.
3. Include the detailed procedural descriptions to corresponding interface chapters in our current draft TS.

We propose the 3rd alternative. This avoids making separate short specification similar to [TS 29.228] for Bootstrapping and Subscriber Certificate. Also, an annex to another system's TS is not a logical solution. Therefore the draft TS "Bootstrapping of application security using AKA and Support for Subscriber Certificates" should contain also the following:

- Detailed description about the protocol in C interface including the BSF-specific usage of Multimedia-Auth-Request/Answer messages. This description is contributed in [S3-030341_A] and [S3-030342_C].
- Detailed description about the protocol in D interface including the NAF-specific usage of Multimedia-Auth-Request/Answer messages. This description is contributed in [S3-030343_D].
- New application logic for Bootstrapping Cx-like interface (C) in BSF and HSS. The description is contributed in [S3-030341_A] and [S3-030342_C].
- New application logic for Cx-like interface (D) in NAF and BSF. The description is contributed in [S3-030343_D].

We propose that the TS will only handle the intra-domain D interface case in the first phase of standardization; potential inter-domain use of D interface is not in the scope in the first phase.

4.1.2 Subscriber Certificate Profile

To enable the home operator control the applications the new TS should also contain:

- Description of Subscriber Certificate Profile (SubCert Profile) or a more general combined profile for applications, that use security association created by the bootstrapping procedure, at least in logical level. The Subscriber Data TS [TS 23.008] can then refer to this information.
- The place for the bit level description of SubCertProfile or more general profile is FFS.

4.2 TS 29.229 Cx and Dx interface based on Diameter protocol (CN4)

4.2.1 6.1.7&6.1.8 Multimedia-Auth-Request/Answer (MAR/MAA) command

Currently there is nothing mandatory to update in TS 29.229. If some upgrading is needed for the Multimedia-Auth-Request/Answer messages for Bootstrapping and the SC in Cx messages, it can be defined here.

4.2.2 "6.3 AVPs" chapter

If new AVP is defined they should be added here. The reason for new AVPs may be to transfer parts of subscriber profile from HSS to BSF. For example, if the SubCert Profile and corresponding application user profiles are not down-loaded from the HSS inside the whole XML schema for the Cx interface user profile (TS 29.228 Annex E) (see section 4.3.1), a special AVP may be needed to down load the SubCert. For example, the User-Data in the MAA message may contain a the following new User-Profile group AVP to ensure the expansibility for future applications:

```
User-Profile ::= <AVP header: TBD>
    1*[SubCert-Profile]
    1*[Some-Future-Profile]
```

4.3 TS 29.228 IMS Cx and Dx Interfaces (CN4)

4.3.1 Annex E

- If the SubCert Profile is included inside the User-Data AVP in the MAA message, the SubCert Profile tag must also be added to the normative definition of XML schema for the Cx interface user profile in annex E. However, this is not needed if, as described in previous section, there is some other AVP for transferring SubCert Profile.

4.4 TS 23.008 Organization of subscriber data (CN4)

The following chapters need upgrading:

4.4.1 3.6 Data related to Core Network services Authorization

Probably this chapter, that is FFS in current 5.3.0 version of TS 23.008, is a possible place for reference to SubCert profile defined in the new [S3-030317] TS.

4.4.2 5.3 IP Multimedia Service Data Storage

This table may be also need to be upgraded.

5. POSSIBLE UPGRADES TO IETF DOCUMENTS

No updating is needed in the HTTP Digest AKA protocol for the Bootstrapping A interface.

The C and D interface potentially require following kind of upgrading to IETF Diameter and its applications specifications:

1. Currently we assume that IMS Multimedia-Auth-Request/Answer command codes will be used also for Bootstrapping-Request/Answer messages (Vendor-Specific-Application-ID is used to differentiate between IMS and Bootstrapping messages.) In the future it may be possible to request a new command code from IANA for Bootstrapping messages. In this case, Diameter command code lists would also need updating.
2. If new AVPs are defined (e.g. for NAF-specific parts of subscriber profile), then some Diameter specifications may need to be updated.
3. There may be need to allocate new values in existing Diameter AVPs code space (e.g. we could allocate own value for bootstrapping Vendor-Specific-Application-Id).

These potential upgrades to IETF documents are FFS.

6. REFERENCES

[3GPP TS 23.008]	Organization of subscriber data (release 5), V5.3.0 (2002-12)
[3GPP TS 23.228]	IP Multimedia Subsystem (IMS); Stage 2 (Release 6); V6.1.0 (2003-03)
[3GPP TS 29.228]	IP Multimedia (IM) Subsystem Cx and Dx Interfaces; Signalling flows and message contents; (Release 5); V5.3.0 (2003-03)
[3GPP TS 29.229]	Cx and Dx interfaces based on the Diameter protocol; Protocol details; (Release 5); V5.3.0 (2003-03)
[DIAMETER]	IETF aaa working group, draft-ietf-aaa-diameter-17.txt
[S3-030317]	Bootstrapping of application security using AKA and Support for Subscriber Certificates; System Description (Release 6)
[S3-030341_A]	Nokia CR: Protocol A in stage 3 detail.
[S3-030342_C]	Nokia CR: Protocol C in stage 3 detail.
[S3-030343_D]	Nokia CR: Protocol D in stage 3 detail.

3GPP TS ab.cde V0.2.0 (2003-05)

Technical Specification

**3rd Generation Partnership Project;
Technical Specification Group Services and System Aspects;
Bootstrapping of application security using AKA and
Support for Subscriber Certificates;
System Description
(Release 6)**



The present document has been developed within the 3rd Generation Partnership Project (3GPP™) and may be further elaborated for the purposes of 3GPP.

The present document has not been subject to any approval process by the 3GPP Organizational Partners and shall not be implemented. This Specification is provided for future development work within 3GPP only. The Organizational Partners accept no liability for any use of this Specification. Specifications and reports for implementation of the 3GPP™ system should be obtained via the 3GPP Organizational Partners' Publications Offices.

Select keywords from list provided in specs database.

Keywords

<keyword[, keyword]>

3GPP

Postal address

3GPP support office address

650 Route des Lucioles - Sophia Antipolis
Valbonne - FRANCE
Tel.: +33 4 92 94 42 00 Fax: +33 4 93 65 47 16

Internet

<http://www.3gpp.org>

Copyright Notification

No part may be reproduced except as authorized by written permission.
The copyright and the foregoing restriction extend to reproduction in all media.

© 2002, 3GPP Organizational Partners (ARIB, CWTS, ETSI, T1, TTA, TTC).
All rights reserved.

Contents

Foreword.....	4
Introduction.....	4
1 Scope	4
2 References	4
3 Definitions, symbols and abbreviations.....	5
3.1 Definitions.....	6
3.2 Symbols.....	6
3.3 Abbreviations	6
4 Generic AKA bootstrapping functions	7
4.1 Requirements and principles for bootstrapping.....	7
4.1.1 Access Independence.....	7
4.1.2 Authentication methods.....	7
4.1.3 Roaming	7
4.2 Bootstrapping architecture	8
4.2.1 Reference model.....	8
4.2.2 Network elements.....	9
4.2.3 Reference points	9
4.3 Procedures	11
4.3.1 Bootstrapping procedures	11
4.3.2 Procedures using bootstrapped Security Association	16
5 Application specific functions using bootstrapping	20
5.1 Support for subscriber certificates.....	20
5.1.1 Introduction	20
5.1.2 Requirements and principles for issuing subscriber certificates	20
5.1.3 Certificate issuing.....	21
A.1 Introduction	22
A.2 Additional requirements and principles.....	22
A.2.1 Usage of Bootstrapping	22
A.2.2 Access independence.....	22
A.2.3 Roaming and service network support.....	22
A.2.4 Home operator control.....	22
A.2.5 Charging principles	22
A.2.6 Subscriber Certificate Profile	22
A.2.7 Service Discovery.....	23
A.3 Certificate issuing architecture	23
A.3.1 Reference model.....	23
A.3.2 Network elements.....	23
A.3.2.1 PKI Portal	23
A.3.2.2 Bootstrapping Server Function	24
A.3.2.3 UE24	
A.3.3 Reference points	25
A.3.3.1 B.....	25
A.4 Certificate issuing procedures.....	26
A.4.1 Certificate issuing.....	26
A.4.2 CA Certificate delivery.....	30
A.5 Functionality in presence of preloaded, long-lasting key pair.....	31
B.1 Introduction	32
B.2 Generic protocol B.....	32

Foreword

This Technical Specification has been produced by the 3rd Generation Partnership Project (3GPP).

The contents of the present document are subject to continuing work within the TSG and may change following formal TSG approval. Should the TSG modify the contents of the present document, it will be re-released by the TSG with an identifying change of release date and an increase in version number as follows:

Version x.y.z

where:

- x the first digit:
 - 1 presented to TSG for information;
 - 2 presented to TSG for approval;
 - 3 or greater indicates TSG approved document under change control.
- y the second digit is incremented for all changes of substance, i.e. technical enhancements, corrections, updates, etc.
- z the third digit is incremented when editorial only changes have been incorporated in the document.

Introduction

This clause is optional. If it exists, it is always the second unnumbered clause.

1 Scope

The present document describes the security features and a mechanism to bootstrap authentication and key agreement for application security from the 3GPP AKA mechanism. Candidate applications to use this bootstrapping mechanism include but are not restricted to subscriber certificate distribution, etc. Subscriber certificates support services whose provision mobile operator assists, as well as services that mobile operator provides.

The scope of this specification includes two parts. The first part presents a generic AKA bootstrapping function, an architecture overview and the detailed procedure how to bootstrap the credential. The second part is the requirement for applications utilizing the bootstrapping function, as well as the procedure of the utilization. Specifically the present document presents signalling procedures for support of issuing certificates to subscribers and the standard format of certificates and digital signatures. It is not intended to duplicate existing standards being developed by other groups on these topics, and will reference these where appropriate.

Editor's note: The specification objects are scheduled currently in phases. For the first phase of standardisation, only the case is considered where bootstrapping server functionality and network application function are located in the same network as the HSS. In later phases, other configurations may be considered.

2 References

The following documents contain provisions that, through reference in this text, constitute provisions of the present document.

- References are either specific (identified by date of publication, edition number, version number, etc.) or non-specific.

- For a specific reference, subsequent revisions do not apply.
- For a non-specific reference, the latest version applies. In the case of a reference to a 3GPP document (including a GSM document), a non-specific reference implicitly refers to the latest version of that document *in the same Release as the present document*.

[<seq> <doctype> <#>[([up to and including]{yyyy[-mm][V<a[b.c]>}{onwards})]: "<Title>".

[1] 3GPP TR 41.001: "GSM Release specifications".

[2] 3GPP TR 21.912 (V3.1.0): "Example 2, using fixed text".

[3] 3GPP TS 31.102: "Characteristics of the USIM Application".

[4] 3GPP TS 33.102: "Security Architecture".

[5] [3GPP TS 23.003: "Numbering, addressing and identification"](#).

[6] [3GPP TS 29.228: "IP Multimedia \(IM\) Subsystem Cx and Dx Interfaces; Signalling flows and message contents"; \(Release 5\): V5.3.0 \(2003-03\)](#).

[7] [3GPP TS 29.229: "Cx and Dx interfaces based on the Diameter protocol"; Protocol details; \(Release 5\): V5.3.0 \(2003-03\)](#)

[DIAMETER] [draft-ietf-aaa-diameter-17.txt, internet draft, IETF aaa working group](#).

[PKCS10] "PKCS#10 v1.7: Certification Request Syntax Standard", RSA Laboratories, May 2000.

[RFC2510] Adams C., Farrell S., "Internet X.509 Public Key Infrastructure Certificate Management Protocols", RFC 2510, March 1999.

[RFC2511] Myers M., et al., "Internet X.509 Certificate Request Message Format", RFC 2511, March 1999.

[RFC2527] Chokhani S., et al, "Internet X.509 Public Key Infrastructure Certificate Policy and Certification Practices Framework", RFC 2527, March 1999.

[RFC2617] Franks J., et al, "HTTP Authentication: Basic and Digest Access Authentication", RFC 2617, June 1999.

[RFC3023] [M. Murata, et al, "XML Media Types", RFC 3023, January 2001.](#)

[RFC3280] Housley R., et al, "Internet X.509 Public Key Infrastructure Certificate and Certificate Revocation List (CRL) Profile", RFC 3280, April 2002.

[RFC 3310] A. Niemi, et al, "Hypertext Transfer Protocol (HTTP) Digest Authentication Using Authentication and Key Agreement (AKA)", RFC3310, September 2002.

[WAPCert] WAP-211-WAPCert, 22.5.2001: <http://www1.wapforum.org/tech/terms.asp?doc=WAP-211-WAPCert-20010522-a.pdf>

[WIM] WAP-260-WIM-20010712, 12.7.2001: <http://www1.wapforum.org/tech/documents/WAP-260-WIM-20010712-a.pdf>

[WPKI] WAP-217-WPKI, 24.4.2001: <http://www1.wapforum.org/tech/documents/WAP-217-WPKI-20010424-a.pdf>

[X.509] ITU-T Recommendation X.509 (1997) | ISO/IEC 9594-8:1997, "Information Technology - Open Systems Interconnection - The Directory: Authentication Framework", 1997.

3 Definitions, symbols and abbreviations

Delete from the above heading those words which are not applicable.

Subclause numbering depends on applicability and should be renumbered accordingly.

3.1 Definitions

For the purposes of the present document, the [following] terms and definitions [given in ... and the following] apply.

Subscriber certificate: a certificate issued to a subscriber. It contains subscriber's own public key and possibly other information such as subscriber's identity in some form.

CA certificate: A Certificate Authority signs all certificates that it issues with its private key. The corresponding Certificate Authority public key is itself contained within a certificate, called a CA Certificate.

example: text used to clarify abstract rules by applying them literally.

3.2 Symbols

For the purposes of the present document, the following symbols apply:

Symbol format

<symbol>	<Explanation>
{ }	Mandatory AVP in the Diameter messages
[]	Optional AVP in the Diameter messages
*	Multiple instances of the AVP possible in the Diameter messages

3.3 Abbreviations

For the purposes of the present document, the following abbreviations apply:

AK	Anonymity Key
AKA	Authentication and Key Agreement
AUTN	Authentication token
AV	Authentication Vector. 3GPP AV=[RAND,AUTN,XRES,CK,IK]
AVP	Attribute-Value-Pair in Diameter messages.
BSF	Bootstrapping server functionality BSF is hosted in a network element under the control of an MNO.
BSP	BootStrapping Procedure
CA	Certificate Authority
CK	Confidential Key
CMP	Certificate Management Protocols
FQDN	Full Qualified Domain Name in URI (e.g. http://FQDN:80)
HSS	Home Subscriber System
IK	Integrity Key
IMPI	IP Multimedia Private Identity
IMPU	IP Multimedia Public Identity
MNO	Mobile network operator
NAF	Operator-controlled network application function functionality. NAF is hosted in a network element under the control of an MNO.
PKCS	Public-Key Cryptography Standards
PKI	Public Key Infrastructure
RAND	Random challenge in authentication
REQ	In Diameter header indicates that the message is a Request.
SCP	Subscriber Certificate Procedure
UE	User Equipment
XRES	Expected response in authentication

4 Generic AKA bootstrapping functions

The 3GPP authentication infrastructure, including the 3GPP Authentication Centre (AuC), the USIM and the 3GPP AKA protocol run between them, is a very valuable asset of 3GPP operators. It has been recognised that this infrastructure could be leveraged to enable application functions in the network and on the user side to communicate in situations where they would not be able to do so without the support of the 3GPP authentication infrastructure. Therefore, 3GPP can provide the “bootstrapping of application security” to authenticate the subscriber by defining a generic bootstrapping function based on AKA protocol.

4.1 Requirements and principles for bootstrapping

Editor's note: The description of AKA bootstrapping shall be added here.

- The bootstrapping function shall not depend on the particular network application function
- The server implementing the bootstrapping function needs to be trusted by the home operator to handle authentication vectors.
- The server implementing the network application function needs only to be trusted by the home operator to handle derived key material.
- It shall be possible to support network application functions in the operator's home network
- The architecture shall not preclude the support of network application function in the visited network, or possibly even in a third network.
- To the extent possible, existing protocols and infrastructure should be reused.
- In order to ensure wide applicability, all involved protocols are preferred to run over IP.

4.1.1 Access Independence

Bootstrapping procedure is access independent. Bootstrapping procedure requires IP connectivity from UE.

4.1.2 Authentication methods

Authentication method that is used to authenticate the bootstrapping function must be dependent on cellular subscription. In other words, authentication to bootstrapping function shall not be possible without valid cellular subscription. Authentication shall be based on AKA protocol.

4.1.3 Roaming

The roaming subscriber shall be able to utilize the bootstrapping function in home network.

Editor's note: For the first phase of standardisation, only the case is considered where bootstrapping server functionality and network application function are located in the same network as the HSS. In later phases, other configurations may be considered.

4.2 Bootstrapping architecture

4.2.1 Reference model

Figure 1 shows a simple network model of the entities involved in the bootstrapping approach, and the protocols used among them.

Editor's note: The names for the reference points, A, B, C, and D need to be decided.

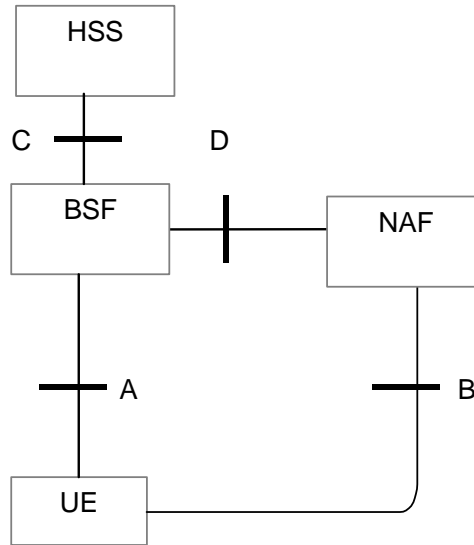

Figure 1: Simple network model for bootstrapping

Figure 2 illustrates a protocol stacks structure in network elements that are involved in bootstrapping of application security from 3G AKA and support for subscriber certificates.

Editor's note: The current protocol stack figure is placed here as a holder. The actual protocols will be defined later.

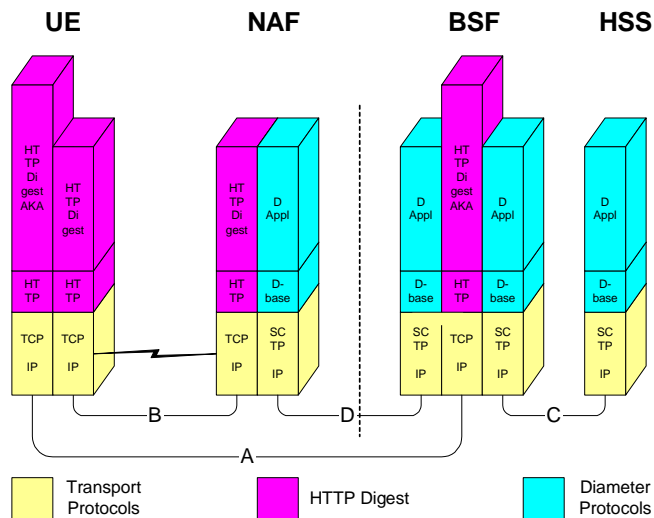

Figure 2: Protocol stack architecture

4.2.2 Network elements

4.2.2.1 Bootstrapping server function (BSF)

A generic bootstrapping server function (BSF) and the UE shall mutually authenticate using the AKA protocol, and agree on session keys that are afterwards applied between UE and an operator-controlled network application function (NAF). The key material must be generated specifically for each NAF independently.

Editor's note: key generation for NAF is ffs. Potential solutions may include:

- *Separate run of protocol A for each request of key material from a NAF*
- *Derivation of NAF-specific keys in BSF*

4.2.2.2 Network application function (NAF)

After the bootstrapping has been completed, the UE and an operator-controlled network application function (NAF) can run some application specific protocol where the authentication of messages will be based on those session keys generated during the mutual authentication between UE and BSF.

General assumptions for the functionality of an operator-controlled network application function (NAF):

- There is no previous security association between the UE and the NAF.
- NAF shall be able to locate and communicate securely with subscriber's BSF.
- NAF shall be able to acquire a shared key material established between UE and the bootstrapping server function (BSF) during running application-specific protocol.

4.2.2.3 HSS

HSS shall store new parameters in subscriber profile related to the usage of bootstrapping function. Possibly also parameters related to the usage of some network application function are stored in HSS.

Editor's note: Needed new parameters are FFS.

4.2.2.4 UE

The required new functionalities from UE are:

- The support of HTTP Digest AKA protocol,
- The capability to derive new key material to be used with protocol B from CK and IK, and
- Support of NAF specific application protocol (see annex A).

4.2.3 Reference points

4.2.3.1 A

The reference point A is between the UE and the BSF. The functionality is radio access independent and can be run in both CS and PS domains.

Editor's notes: The solution for CS domain is ffs.

4.2.3.1.1 Functionality

Reference point A provides mutual authentication between the UE and the BSF entities. It allows the UE to bootstrap the session keys based on the 3G infrastructure. The session key as result of key agreement functionality, is used to support further applications e.g. certificate issuer.

4.2.3.1.2 Protocol

Protocol A is in format of HTTP Digest AKA, which is specified in [RFC3310]. It is based on the 3GPP AKA [4] protocol that requires information from USIM and/or ISIM. The interface to the USIM is as specified for 3G [3].

4.2.3.2 B

Protocol B is the application protocol which is secured using the keys material agreed between UE and BSF as a result of the run of protocol A. For instance, in the case of support for subscriber certificates, it is a protocol, which allows the user to request certificates from the NAF. In this case NAF would be the PKI portal.

4.2.3.3 C

Protocol C is used between the BSF and the HSS to allow the BSF to fetch the required authentication information and subscriber profile information from the HSS. The interface to the 3G Authentication Centre is HSS-internal, and it need not be standardised as part of this architecture.

4.2.3.4 D

Protocol D is used by the NAF to fetch the key material agreed in protocol A from the BSF. It may also be used to fetch subscriber profile information from BSF.

4.3 Procedures

This chapter specifies in detail the format of the bootstrapping procedure that is further utilized by various applications. It contains the AKA authentication procedure with BSF, and latter the key material generation procedure.

4.3.1 Bootstrapping procedures

[The bootstrapping procedures consist of executions of the protocol A and protocol C that are specified in stage 3 detail in sections 4.3.1.1 and 4.3.1.2 respectively. The following overall message sequence diagram outlines the whole successful bootstrapping procedure.](#)

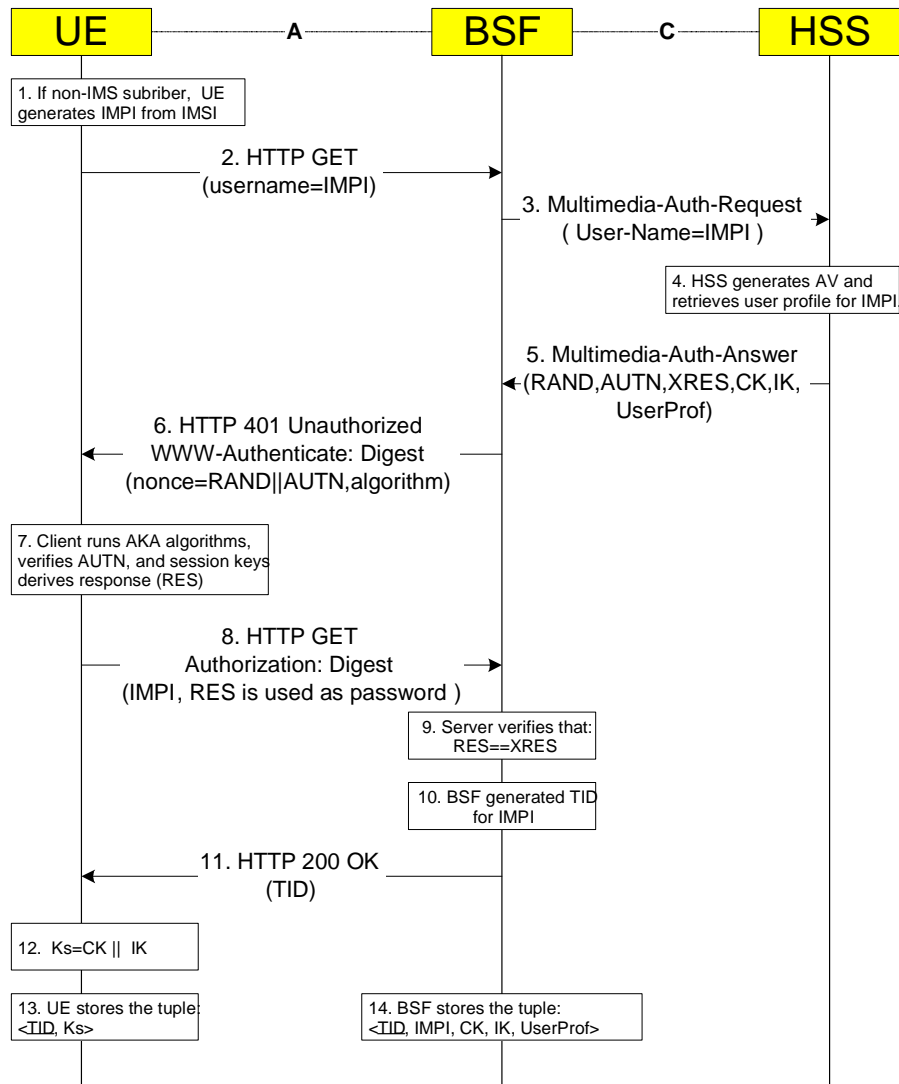

[Figure 3: The bootstrapping procedure](#)

[Steps 1-2 and 6-14 are described in the A interface chapter 4.3.1.1 and steps 3-5 in the B interface chapter 4.3.1.2.](#)

4.3.1.1 Protocol A

4.3.1.1.1 Successful case

When a UE wants to interact with an NAF, it shall first perform a bootstrapping authentication (see Figure 3). ~~Editor's notes: Protocol C related procedure will be added here in future development. It may re-use Cx interface that is specified in TS 29.228.~~

1. ~~The UE sends an HTTP request towards the BSF.~~ A non-IMS subscriber shall construct a private user identity from IMSI number according to [5].

2. The UE sends an HTTP request containing the User Private Identity (IMPI) towards its home BSF. The IMPI is given in Request-Line.

```
GET /?username=impi HTTP/1.1
```

3. BSF retrieves the user profile and a challenge, i.e. the Authentication Vector (AV). ~~AV = RAND||AUTN||XRES||CK||IK~~ by protocol C from the HSS (c.f. section 4.3.1.2).

3.6. Then BSF forwards the challenge RAND and AUTN to the UE in the HTTP 401 message (without the CK, IK and XRES). This is to demand the UE to authenticate itself. The challenge contains RAND and AUTN that are populated in nonce field [RFC3310].

```
HTTP/1.1 401 Unauthorized
WWW-Authenticate: Digest
  realm="bsfServer@operatornetwork",
  nonce="CjPk9mRqNuT25eRkaJM09uTl9nM09uTl9nMz5OX25PZz==",
  qop="auth-int",
  opaque="5ccc069c403ebaf9f0171e9517f40e41",
  algorithm=AKAv1-MD5
```

4.7. The UE calculates the message authentication code (MAC) so as to verify the challenge from authenticated network; the UE also calculates CK, IK and RES. This will result in session keys IK and CK in both BSF and UE.

5.8. The UE sends request again, with the Digest AKA RES as the response to the BSF.

```
GET /?username=impi HTTP/1.1
Authorization: Digest
  username="impi",
  realm=" bsfServer@operatornetwork",
  nonce="CjPk9mRqNuT25eRkaJM09uTl9nM09uTl9nMz5OX25PZz==",
  uri="/?username=impi",
  qop="auth-int",
  nc=00000001,
  cnonce="0a4f113b",
  response="6629fae49393a05397450978507c4ef1",
  opaque="5ccc069c403ebaf9f0171e9517f40e41"
```

6.9. The BSF server shall check the received Digest equals to the expected value. If so, it means the RES equals to the XRES that is in the AV, which means the UE is authenticated.

10. The BSF generates a TID for the IMPI.

7.11. The BSF shall send the successful response in 200 OK message to the UE to indicate the success of the authentication.

The BSF shall insert the transaction ID into the message body that is integrity protected, and the calculation of response digest is specified in [RFC2617]. The multipart definition follows [RFC2023].

```

HTTP/1.1 200 OK
Authentication-Info:
  qop="auth-int",
  rspauth="6629fae49393a05397450978507c4ef1",
  cnonce="0a4f113b"
Content-Type: application/3gpp-bsf+xml
Content-Length:

<?xml version="1.0" encoding="UTF-8"?>
<bsf xmlns="urn-to-xml-schema-of-3gpp-bsf "
  bsf-tid="base64 encoded TID"/>

```

The XML Schema of the bsf element is specified below. The uniform resource name (URN) for 3gpp-bsf namespace is FFS.

```

<?xml version="1.0" encoding="UTF-8"?>
<xs:schema targetNamespace="urn-to-xml-schema-of-3gpp-bsf"
  xmlns:tns="urn-to-xml-schema-of-3gpp-bsf"
  xmlns:xs="http://www.w3.org/2001/XMLSchema"
  elementFormDefault="qualified"
  attributeFormDefault="unqualified">

  <!-- This import brings in the XML language attribute xml:lang-->
  <xs:import namespace="http://www.w3.org/XML/1998/namespace"
    schemaLocation="http://www.w3.org/2001/xml.xsd"/>

  <xs:element name="bsf" type="tns:bsf"/>

  <xs:complexType name="bsf">
    <xs:sequence>
      <xs:attribute name="bsf-tid" type="xs:base64Binary"/>
    </xs:sequence>
  </xs:complexType>
</xs:schema>

```

812. The key material Ks is generated in ~~both BSF and~~ UE by concatenating CK and IK. The Ks is used for securing the protocol B.

Editor's note: The key material Ks is 256 bits long. It is up each NAF to make the usage of the key material specifically.

13. The UE stores the tuple <TID,Ks>

14. The BSF stores the tuple <TID,IMPI,CK,IK,UserProfile>

~~9. BSF may supply a transaction identifier to UE in the cause of protocol A.~~

4.3.1.1.2 User authentication failure case

If the response is verified to be different than expected, the BSF shall send a HTTP 401 Unauthorized message in step 8, indicating that BSF does not wish to accept the request. It may return a HTTP 401 Unauthorized response that includes a WWW-Authenticate header field containing another challenge applicable to the requested resource.

```

HTTP/1.1 401 Unauthorized
WWW-Authenticate: Digest
  realm="bsfServer@operatornetwork",
  qop="auth-int",
  nonce="9uQzNPbk9jM05Pbl5Pbl5DIz9uTl9uTl9jM0NTHk9uXk==",
  opaque="dcd98b7102dd2f0e8b11d0f600bfb0c093",
  algorithm=AKAv1-MD5

```

After N failed attempts of authentication procedure, the application may indicate end user a failure message. The exact value of N is defined by local policy.

4.3.1.1.3 Network authentication failure case

In case the UE fails at authenticating the network based on the MAC generated locally, the UE shall abort the procedure from step 6.

4.3.1.1.4 Synchronisation failure

If the UE considers the sequence number in the challenge to be not in the correct range, it shall send *synchronisation failure* back to BSF. The parameter AUTS contains the concealed value of the counter value SQN_{MS} in the UE.

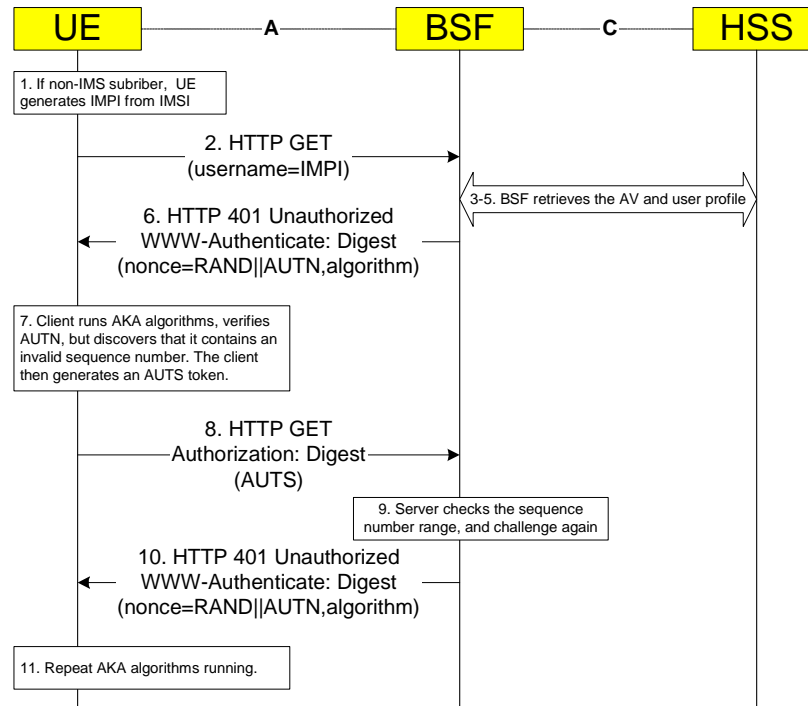

Figure 4: The message flow of bootstrapping procedure in sequence number synchronization failure case

The message flow in Figure 4 shall be different since step 7 in the Figure 3. The client identifies the sequence number is out of synchronization. The client shall generate the AUTS parameter according to [4].

In step 8, AUTS parameter is populated in Authorization header, as specified in [RFC3310].

```

GET /?username=impi HTTP/1.1
Authorization: Digest
  username="impi",
  realm="bsfServer@operatornetwork",
  nonce="CjPk9mRqNuT25eRkaJM09uTl9nM09uTl9nMz5OX25PZz==",
  uri="/?username=impi",
  qop="auth-int",
  nc=00000001,
  cnonce="0a4f113b",
  response="4429ffe49393c02397450934607c4ef1",
  opaque="5ccc069c403ebaf9f0171e9517f40e41",
  auts="5PYxMuX2NOT2NeQ="
  
```

In step 10, the BSF shall send another challenge based on new range of sequence number.

```

HTTP/1.1 401 Unauthorized
WWW-Authenticate: Digest
  realm="bsfServer@operatornetwork",
  qop="auth-int",
  nonce="9uQzNPbk9jM05Pbl5Pbl5DIz9uTl9uTl9jM0NTHk9uXk==",
  opaque="dcd98b7102dd2f0e8b11d0f600bfb0c093",
  algorithm=AKAv1-MD5
  
```

4.3.1.2 Protocol C

The Bootstrapping C interface performs the retrieval of an authentication vector and user profile data by BSF from the HSS. The procedure corresponds to the step 3 to 5 in Figure 3, and is defined in detail as below:

3. The BSF shall send the following Bootstrapping request to the HSS in format of Multimedia-Auth-Request (MAR) message. The content of the message is given below in the same format as in [7]. The curly brackets indicate it is a mandatory AVP. The square brackets indicate it is an optional AVP. The address refers to the Fully Qualified Host Name (FQDN).

```
<Multimedia-Auth-Request> ::= <Diameter Header: 303, REQ >
  < Session-Id >
  { Vendor-Specific-Application-Id }
  { Auth-Session-State } ; NO_STATE_MAINTAINED
  { Origin-Host } ; Address of BSF
  { Origin-Realm } ; Realm of BSF
  { Destination-Realm } ; Realm of HSS
  [ Destination-Host ] ; Address of the HSS
  { User-Name } ; IMPI from UE
  { Public-Identity } ; Empty value
  [ SIP-Auth-Data-Item ] ; Omitted
  [ SIP-Number-Auth-Items ] ; value "1".
  [ Server-Name ] ; Omitted
  *[ AVP ]
  *[ Proxy-Info ]
  *[ Route-Record ]
```

The content of Vendor-Specific-Application-ID according [DIAMETER] section 6.11 is:

```
<Vendor-Specific-Application-Id> ::= <AVP header: 260>
  1* [Vendor-Id] ; 3GPP is 10415
  0*1 {Auth-Application-Id} ; value for BS is FFS
  0*1 {Acct-Application-Id} ; Omitted
```

When determining the value of Destination-Host AVP the BSF can use redirector function (SLF) to resolve the address of the HSS if needed (see [7], section 5.5). The BSF may set the Auth-Session-State AVP to NO_STATE_MAINTAINED to inform that the HSS does not need to maintain any status information for this session according [7] section 5.3. The User-name is the IMS Private User Identity (IMPI) as required in [6] section 6.1.3. The mandatory Public-Identity may be set to contain non-meaningful "empty" value because the HSS application logic of the Bootstrapping does not check, as IMS MM application does, coherence of the IMPI and the User Public Identity (IMPU). Because the bootstrapping procedure requires only one authentication vector the SIP-Number-Auth-Items AVP may be omitted or set to 1 (default) according [7] section 6.3.12. The optional Server-Name AVP may be omitted.

4. When the HSS receives the MAR message, the HSS shall derive the user Authentication Vector (AV) information according the IMPI and populates into SIP-Auth-Data AVP defined in [6]. The HSS shall also fetch the user profile (e.g. Subscriber Certificate profile) and populates it to the IMS User-Data AVP defined in [6] and [7].

Editor's note: This requires an addition to XML schema of User-Data AVP defined in [6]. This updating is not yet accepted or contributed. Another alternative is to define a new AVP for user profile.

5. The HSS shall send the following Bootstrapping response in format of Multimedia-Auth-Answer (MAA) message back to the BSF.

```

< Multimedia-Auth-Answer > ::= < Diameter Header: 303 >
  < Session-Id >
  { Vendor-Specific-Application-Id }
  [ Result-Code ]
  [ Experimental-Result ]
  { Auth-Session-State } ; NO_STATE_MAINTAINED
  { Origin-Host } ; Address of HSS
  { Origin-Realm } ; Realm of HSS
  [ User-Name ] ; IMPI
  [ Public-Identity ] ; Omitted
  [ SIP-Number-Auth-Items ] ; value "1"
  *[ SIP-Auth-Data-Item ] ; Contains one user's AV info
  [ User-Data ] ; User profile
  *[ AVP ]
  *[ Proxy-Info ]
  *[ Route-Record ]

```

The HSS shall set the mandatory Auth-Session-State AVP to NO_STATE_MAINTAINED to inform that the HSS does not require the BSF to maintain any status information. The User-name AVP (IMPI) may be sent back for checking. The only required authentication vector is send in the SIP-Auth-Data-Items AVP and the AVP SIP-Number-Auth-Items AVP may be omitted or set to 1 (default).

The MAR/MAA sequence in the C interface must not change possible status information of the possible simultaneously ongoing IMS MM application sessions.

When the BSF receives the MAA message, the BSF stores temporarily the tuple <IMPI,XRES,CK,IK,UserProfile> for further use inside the bootstrapping procedure.

4.3.2 Procedures using bootstrapped Security Association

After UE is authenticated with the BSF, every time the UE wants to interact with an NAF the following steps are executed as depicted in Figure.4:

UE starts protocol B with the NAF

- In general, UE and NAF will not yet share the key(s) required to protect protocol B. If they already do, there is no need for NAF to invoke protocol D.
- It is assumed that UE supplies sufficient information to NAF, e.g. a transaction identifier, to allow the NAF to retrieve specific key material from BSF.
- The UE derives the keys required to protect protocol B from the key material.

NAF starts protocol D with BSF

- The NAF requests key material corresponding to the information supplied by the UE to the NAF (e.g. a transaction identifier) in the start of protocol B.
- The BSF supplies to NAF the requested key material.
- The NAF derives the keys required to protect protocol B from the key material in the same way as the UE did.

NAF continues protocol B with UE

Once the run of protocol B is completed the purpose of bootstrapping is fulfilled as it enabled UE and NAF to run protocol B in a secure way.

Editor's note: Message sequence diagram presentation and its details [in protocol B](#) will be finalized later.

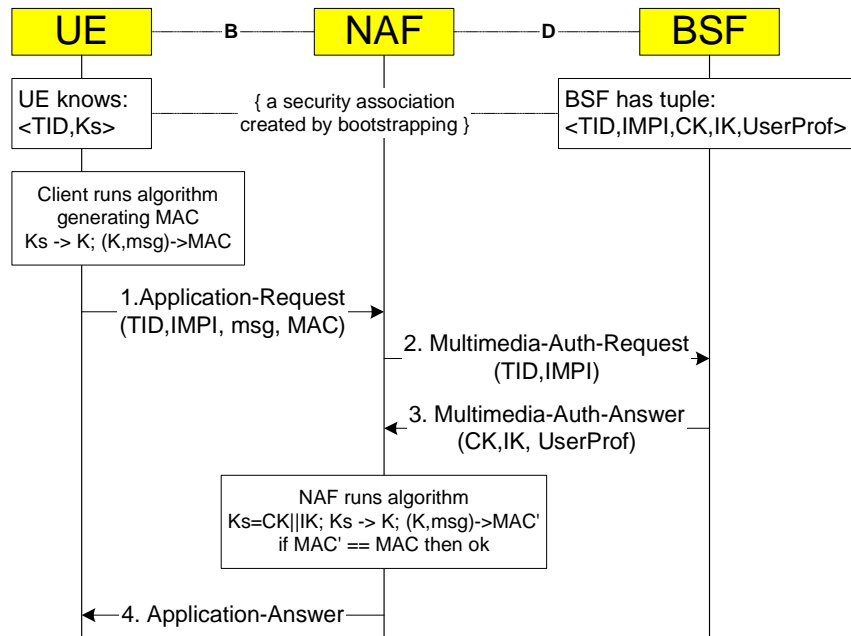

MAC represents all credentials **msg** is appl. specific dataset
UserProf is application specific part of user profile

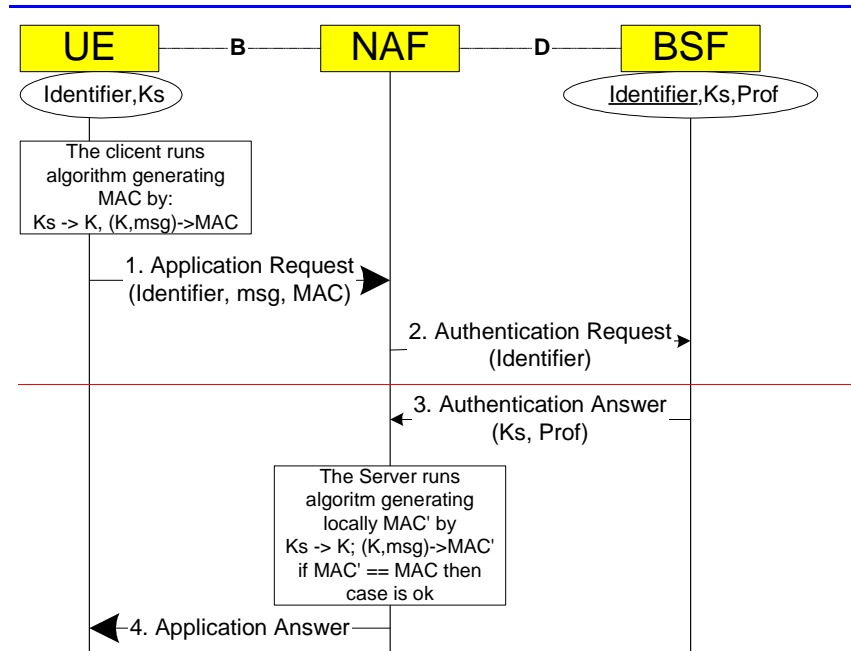

MAC represents all credentials **msg** is appl. specific dataset
Prof is application specific part of user profile

Figure 3: The bootstrapping usage procedure

4.3.2.1 Protocol D

The protocol D performs the retrieval of an authentication vector and user profile data by NAF from BSF. The application procedure of protocol D part refers to step 2 and 3, which are defined in stage 3 details as below:

2. The NAF shall send Authentication Request in the format of Multimedia-Auth-Request (MAR) message to the BSF. The content of the message is given here in the same format as in [7]. The curly brackets indicate mandatory AVP. The square brackets indicate optional AVP. The address refers to the Fully Qualified Host Name (FQDN).

```

< Multimedia-Auth-Request> ::= <Diameter Header: 303, REQ >
  < Session-Id >
  { Vendor-Specific-Application-Id }
  { Auth-Session-State } ; NO_STATE_MAINTAINED
  { Origin-Host } ; Address of NAF
  { Origin-Realm } ; Realm of NAF
  { Destination-Realm } ; Realm of BSF
  [ Destination-Host ] ; Address of the BSF
  { User-Name } ; IMPI from UE
  { Public-Identity } ; Empty value
  [ SIP-Auth-Data-Item ] ; Omitted
  [ SIP-Number-Auth-Items ] ; value "1".
  [ Server-Name ] ; Omitted
  *[ AVP ]
  *[ Proxy-Info ]
  *[ Route-Record ]

```

The content of Vendor-Specific-Application-ID according [DIAMETER] section 6.11 is:

```

<Vendor-Specific-Application-Id> ::= <AVP header: 260>
  1* [Vendor-Id] ; 3GPP is 10415
  0*1 {Auth-Application-Id} ; value for appl. is FFS
  0*1 {Acct-Application-Id} ; Omitted

```

The User-Name is the IMPI from send by the UE.

Editor's note: The transfer of the Transaction Identity (TID) (base 64 coded octet string) is FFS. It may be sent in concatenation with the IMPI in User-Name AVP or as its own AVP.

The Destination-Realm is derived from realm part of the IMPI. When determining the value of Destination-Host AVP in home network the NAF can use redirector function (SLF) to resolve the address of the BSF if needed (see [7] section 5.5). The derivation of the Destination-Host in the visited network case is FSS.

The NAF may set the Auth-Session-State AVP to NO_STATE_MAINTAINED to inform that the BSF does not need to maintain any status information for this session according [7] section. 5.3. The User-name is the IMS Private User Identity (IMPI) as required in [6] section. 6.1.3. The mandatory Public-Identity may be set to contain non-meaningful "empty" value. Because the application requires only one authentication vector the SIP-Number-Auth-Items AVP may be omitted or set to 1 (default) according [7] section. 6.3.12. The optional Server-Name AVP may be omitted.

3. In the successful case the BSF has a tuple <TID,IMPL,CK,IK,UserProf> identified by Transaction Identity (TID). When the BSF receives the MAR it checks the existence of the tuple and matches the stored and received IMPIs. If checking fails the BSF sends Multimedia-Auth-Answer (MAA) with Result-Code set to indicate the error type. In successful case the Result-Code is set to 2xxx as defined in [DIAMETER].

The BSF derives the user authentication vector information according the IMPI and packs in into SIP-Auth-Data AVP defined in [6]. The HSS fetches also the user profile (e.g. Subscriber Certificate profile) and packs it to the IMS User-Data AVP defined in [6] and [7].

Editor's note: This requires an addition to XML schema of User-Data AVP defined in [TS 29.228]. This updating is not yet accepted or contributed. Another alternative is to define a new AVP for user profile.

After that the BSF shall send the Authentication Answer in format of the following Multimedia-Auth-Answer (MAA) message back to the NAF.

```

< Multimedia-Auth-Answer > ::= < Diameter Header: 303 >
  < Session-Id >
  { Vendor-Specific-Application-Id }
  [ Result-Code ] ; 2xxx in successful case
  [ Experimental-Result ]
  { Auth-Session-State } ; NO_STATE_MAINTAINED
  { Origin-Host } ; Address of BSF
  { Origin-Realm } ; Realm of BSF
  [ User-Name ] ; IMPI
  [ Public-Identity ] ; Omitted
  [ SIP-Number-Auth-Items ] ; value "1"
  *[ SIP-Auth-Data-Item ] ; Contains one user's AV info
  [ User-Data ] ; User profile
  *[ AVP ]
  *[ Proxy-Info ]
  *[ Route-Record ]

```

The BSF should set the mandatory Auth-Session-State AVP to NO_STATE_MAINTAINED to inform that the BSF does not require the NAF to maintain any status information. The User-name AVP (IMPI) may be sent back for checking. The only required authentication vector is send in the SIP-Auth-Data-Items AVP and the AVP SIP-Number-Auth-Items AVP may be omitted or set to 1 (default).

When the MAA message is send the BSF can remove the tuple <TID,IMPU,CK,IK,UserProf> stored by bootstrapping procedure.

5 Application specific functions using bootstrapping

5.1 Support for subscriber certificates

5.1.1 Introduction

Digital signatures can be used, for instance, to secure mobile commerce, service authorization and accounting. But digital signature by itself is not enough; there is need of a global support for authorization and charging. Thus 3GPP shall use global and secure authorization and charging infrastructure of mobile networks to support local architecture for digital signatures.

Subscriber certificates provide a migration path towards global Public Key Infrastructure (PKI). Local architecture for digital signatures can be deployed incrementally; an operator can choose to deploy independently of the others. On the other hand, the existence of subscribers and service providers that use digital signatures makes it easier to build global PKI.

3GPP systems shall issue subscriber certificates in order to authorize and account for service usage both in home and in visited network. This requires specification of:

1. Procedures to issue temporary or long-term certificates to subscribers.
2. Standard format of certificates and digital signatures, e.g. re-using wireless PKI.

The mechanism shall allow a cost efficient implementation of the security support of the UE. It will also enable a user's anonymity towards the service provider, whilst the user who invoking the service, can be identified by the network.

Subscriber certificates support services whose provision mobile operator assists, as well as services that mobile operator provides. There is no need to standardize those services. Also, the communication between service provider and the operator (in the role of certificate issuer) need not be standardized.

5.1.2 Requirements and principles for issuing subscriber certificates

The following prerequisites for issuing of subscriber certificates exists:

- The shared key material is available for the UE application, which does the certificate request and operator CA certificate retrieval.

5.1.2.1 Requirements on protocol B

The requirements for protocol B are:

- UE is able to request for subscriber's certification from the PKI portal that plays the role of the NAF over a network connection.
- NAF is able to authenticate UE's certificate request.
- UE is able to acquire an operator's CA certificate over the network connection.
- UE is able to authenticate the NAF response (i.e., operator CA certificate delivery).
- The procedure is independent of the access network used.
- The NAF should have access to the subscriber profile to check the certification policies. This means that the protocol D (cf. clause 5.1.2.2) should have support for retrieving a subset of the subscriber profile.
- The response and delivery of certificate to UE must be within a few seconds after the initial certification request.

5.1.2.2 Requirements on protocol D

The requirements for protocol D are:

- NAF is able to communicate securely with a subscriber's BSF.
- The NAF is able to send a key material request to the BSF.
- The BSF is able to send the requested key material to the NAF.
- The NAF is able to get the subscriber profile from BSF.

Editor's note: in later phases there is an additional requirement that the NAF and the BSF may be in different operators' networks.

5.1.3 Certificate issuing

Annex <A> (informative): Support for subscriber certificates based on bootstrapping

A.1 Introduction

This annex describes how operators issue the subscriber certificates and deliver operator CA certificates to subscribers.

A.2 Additional requirements and principles

A.2.1 Usage of Bootstrapping

Issuing procedures of the subscriber certificate and operator CA certificate shall be secured by using shared keys obtained from bootstrapping function.

A.2.2 Access independence

Subscriber certificate and operator CA certificate issuing procedures are access independent. Certificate issuing procedures require IP connectivity from UE.

A.2.3 Roaming and service network support

The roaming subscriber shall be able to request subscriber certificates and operator CA certificates from home network.

Editor's note: Certificate requests to any than home network may be supported in later phase of the present specification.

A.2.4 Home operator control

Home operator shall be able to control the issuing of subscriber certificates. The control includes to whom the certificates are allowed to issue and the types of issued certificates.

Delivery of operator CA certificates is always allowed.

Editor's note: For the first phase of standardisation, only the case is considered where bootstrapping server functionality and network application function are located in the same network as the HSS. Thus is the first phase the home network control does not require any communication between home and visited networks. In later phases, when also visited network may issue certificates, standardized way of transferring the control information from home network to visited network is needed.

A.2.5 Charging principles

The operator shall be capable to charge issuing of subscriber certificates or delivery of operator CA certificates.

Editor's note: The charging mechanism and whether it needs to be standardized in 3GPP is FFS.

A.2.6 Subscriber Certificate Profile

Subscriber certificate profile shall be based on WAP Certificate and CRL Profile [WAPCert], which in turn is based on profiles defined in [RFC3280] and [X.509]. A certificate profile defines the format and semantics of certificates in a specific context.

Editor's note: Applicability of other certificate profile specifications, e.g. RFC 3281, ETSI QC profile is FFS.

The following certificate extensions shall be filled with the information given by the UE in the certification request:

- Intended certificate usage (i.e., using keyUsage and/or extKeyUsage extensions [WAPCert]).
- Subscriber identities (i.e., subject name field, and possible additional identities defined in the subjectAltName extension [WAPCert]). Operator CA shall authorize each suggested subscriber identity.
- Proof of key origin (i.e., keyGenAssertion). Operator CA shall verify the proof of key origin if it is presented.

Note: It is not mandatory for Operator CA to insert these suggested extensions by UE to the certificate. Rather, Operator CA shall issue certificates based on its certification policies. It may write a certification practice statement (CPS) [RFC2527], where it describes the general requirements and steps taken during the certificate issuing.

A.2.7 Service Discovery

The addresses of bootstrapping server and PKI portal may be pre-configured to the UE or UICC. The possible service discovery or over-the-air configuration mechanism are FFS.

Editor's note: For the first phase of standardisation, when bootstrapping server functionality and network application function are always located in home network, therefore pre-configuration of addresses is sufficient. In later phases, however, when UE needs to address of PKI Portal in the visited network, more flexible is needed in the solution.

A.3 Certificate issuing architecture

A.3.1 Reference model

4 Figure 5 below shows a simple network model of the entities involved in the certificate issuing, and the protocols used between the network entities.

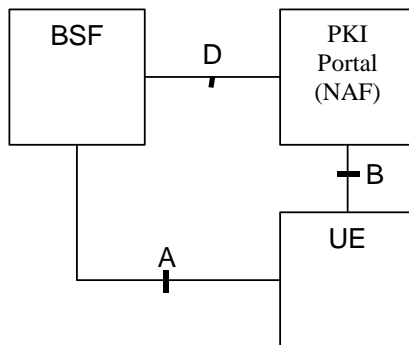

Figure 5: Simple network model for certificate issuing.

A.3.2 Network elements

A.3.2.1 PKI Portal

A PKI Portal shall issue a certificate for UE and deliver an operator CA certificate. In both cases, requests and responses are protected by shared key material that has been previously established between UE and a BSF

In PKI terms, the PKI portal is a Registration Authority (RA) who authenticates the certification request based on cellular subscription (using protocol A). PKI Portal may also function as a Certification Authority (CA) who will issue certificates. However, this task may also be done in an existing PKI infrastructure towards which the PKI Portal would function as a RA only, and the CA would be in the PKI infrastructure.

A.3.2.2 Bootstrapping Server Function

The bootstrapping server function (BSF) shall support the PKI portal by providing the authentication (c.f. section 4.2.2.1) and subscriber profile information (i.e., whether subscriber is able to enrol a certain types of subscriber certificate).

A.3.2.3 UE

The required new functionality from UE is the support of the protocol B (i.e. certification enrolment protocol) that is protected using the shared keys established during bootstrapping function.

In addition UE may have the capability to generate public and private key pairs, store the private key part to a non-volatile memory (e.g., in UICC), and protect the usage of the private key part (e.g., with a PIN).

A.3.3 Reference points

A.3.3.1 B

A.3.3.1.1 General description

In the certificate issuing, protocol B is used to for:

- The operator CA certifying subscriber's public keys in format of certificates, and
- The delivery of the Operator CA certificate to the UE.

During subscriber certificate issuing, UE may request a certification of a public key. The supported request formats shall include PKCS#10. It is used to encapsulate the public key and other attributes (i.e., subject name, intended key usage, etc.). The request is transported from the UE to the PKI Portal using protocol B. Upon receiving the certification request, PKI portal will certify the public key according to its own certification practice policies and subscriber profile which is fetched through BSF from HSS. If PKI Portal decides to certify the public key, it will digitally sign it, and generate the corresponding certificate, which is returned from PKI Portal to the UE, using protocol B.

During operator CA certificate delivery, the UE may request the PKI Portal to deliver operator CA's certificate. In the corresponding response, the PKI Portal will deliver the CA's certificate to the UE. Since the operator's CA certificate is typically a self-signed certificate and the validation of certificates signed by this CA is based on this particular CA certificate, it needs to be delivered over authenticated and secured channel.

Authentication, integrity protection, and possibly encryption of the protocol B messages are based on the BSF generated shared secret.

A.3.3.1.2 Functionality and protocols

Editor's note: From five alternatives investigated in S3-030073 and S3-030036, only the following two have been agreed to add to the present document as potential solutions.

A.3.3.1.2.1 PKCS#10 with HTTP Digest Authentication

HTTP Digest Authentication scheme [RFC2617] may be done with BSF shared key material the following way.

- UE makes a blank HTTP request to the NAF
- NAF returns a HTTP response with "WWW-Authenticate" header indicating that HTTP Digest Authentication is needed. Quality of protection (qop) attribute is set to "auth-int" meaning that the content in following HTTP requests and responses are integrity protected.
- UE calculates the correct response to the "WWW-Authenticate" header using the *identifier* (base64 encoded) as the username and the session key K (base64 encoded) as the password. The session key K is has been previously derived from the key material Ks that resulted from running protocol A. HTTP Digest Authentication parameters are returned in the "Authorization" header of HTTP Response.
- NAF validates the "Authorization" header and upon successful validation, performs the requested task. In the corresponding HTTP response, NAF calculates the relevant values for "Authentication-Info" header, which is used to authenticate and integrity protect the NAF response.
- UE validates the "Authentication-Info" header and upon successful validation, accepts the payload in the HTTP response.

A PKCS#10 [PKCS10] based certification request is sent to the CA NAF using a HTTP POST request, which MUST be authenticated and integrity protected by HTTP Digest Authentication.

Certificate is delivered using the HTTP response, which MAY be authenticated and integrity protected by HTTP Digest Authentication. The content-type of the HTTP response is either "application/x-x509-user-cert" or "application/vnd.wap.cert-response" as specified in [WPKI].

The UE requests a CA certificate delivery by sending a plain HTTP GET request with specific parameters in the request URI . The request MAY be authenticated and integrity protected by HTTP Digest Authentication.

CA certificate is delivered using the HTTP response, which MUST be authenticated and integrity protected by HTTP Digest Authentication. The content-type of the HTTP response would be “application/x-x509-ca-cert”. Note that the user should always be notified when a new CA certificate is taken into use.

A.3.3.1.2.2 Certificate Management Protocols (CMP)

Certificate Management Protocols (CMP) [RFC2510] describes a set of messages that can be used between different PKI components, e.g., between the CA and the end entity as well as between two CAs. The messages used in the specification have the following general message structure called PKIMessage. PKIMessage contains four fields: PKIHeader, PKIBody, optional PKIProtection, and optional certificate list. The PKIHeader contains information, which is common to many PKI messages. The PKIBody contains the message-specific information. The PKIProtection, when used, contains bits that protect the PKI message. The certificate list can contain certificates that may be useful to the recipient. [RFC2510]

In CMP, authentication is achieved by the PKI issuing the end entity with a secret value (initial authentication key) and reference value (used to identify the transaction) via some out-of-band means. The initial authentication key can then be used to protect relevant PKI messages (see chapters 2.2.1.2. and 3.1.3 of [RFC2510] for details). Also a replay prevention mechanism is specified.

The supported certificate request formats are PKCS#10 [PKCS10] and CRMF [RFC 2511]. The certificate request is inserted in the PKIBody field of the PKIMessage. The response to the certificate request is a CertRespMessage that is inserted in the PKIBody field of the PKIMessage. The CertRespMessage contains the status of the response, and if certificate request was approved the certificate itself. CMP supports also a certification procedure where the key generation happens in the CA rather than in the UE. However, CMP states that this procedure is only optionally implemented by CAs. See more details in [RFC2510].

CMP defines data structures, which can support mechanism where the CA is able to publish its current public key using self-signed certificates that are distributed via some “out-of-band” means. Alternatively the self-signed CA certificate can be published on a directory server and a hash of the certificate can be distributed via some out-of-band means. The idea is that anyone who has securely received a hash value can verify the authenticity of the CA certificate. The structure of such a self-signed out-of-band certificate or hash is specified in the RFC. However, the way how the CA publishes the self-signed certificate and/or securely delivers the hash value is considered out-of-scope for CMP (see chapter 3.2.5 of [RFC2510]).

A.4 Certificate issuing procedures

A.4.1 Certificate issuing

Editor's note: From five alternatives investigated in S3-030073 and S3-030036, only the following two have been agreed to add to the present document as potential solutions.

A.4.1.1 Certificate issuing using PKCS#10 with HTTP Digest Authentication

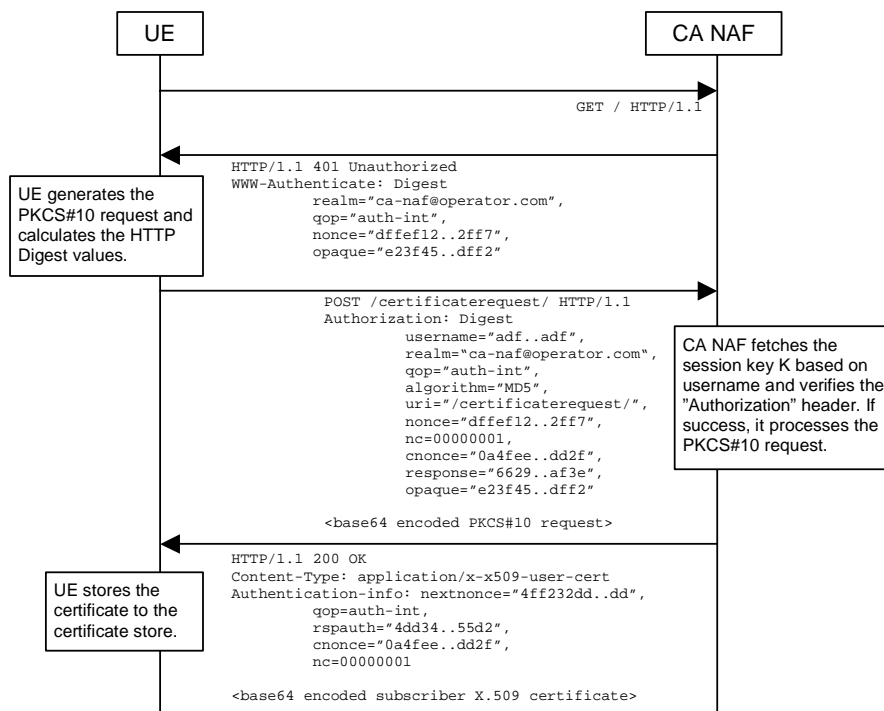

Figure 5: Certificate request using PKCS#10 with HTTP Digest Authentication.

The sequence diagram above describes the certificate request when using PKCS#10 with HTTP Digest. The sequence starts with an empty HTTP request to CA NAF. The CA NAF responds with HTTP response code 401 “Unauthorized” which contains a WWW-Authenticate header. The header instructs the UE to use HTTP Digest authentication.

The UE generates a PKCS#10 request with the subject name, public key, additional attributes and extensions. Then it will generate the HTTP request by calculating the Authorization header values using the identifier it received from the BSF as username and the session key K.

When CA NAF receives the request, it will verify the Authorization header by fetching the session key K from the bootstrapping server using the identifier, then calculating the corresponding digest values using K, and finally comparing the calculated values with the received values in the Authorization header. If the verification succeeds, the incoming PKCS#10 request is taken in for further processing. If the CA NAF is actually a registration authority (RA NAF), the PKCS#10 request is forwarded to CA using any protocol available (e.g., CMC or CMP). After the PKCS#10 request has been processed and a certificate has been created, the new certificate is returned to the CA NAF. It will generate a HTTP response containing the certificate. The CA NAF may use session key K to integrity protect and authenticate the response.

When UE receives the subscriber certificate, it is stored to local certificate management system.

NOTE: On board key generation is already defined in the WIM specification [WIM] issued by Open Mobile Alliance (OMA) group.”

A.4.1.2 Certificate issuing with CMP

CMP defines two methods to do the certificate issuing: basic authenticated scheme and centralized scheme. In the basic authenticated scheme the key generation happens in the UE while in the centralized scheme the key generation is done in the CA (or RA). CMP states that the support for the basic authenticated scheme for certificate issuing is mandatory for CAs while the support for the centralized scheme is optional. See more details in chapters 2.2 and B8 of [RFC2510].

The messages can be transported using various methods such as file based protocol, (such files can be used to transport PKI messages e.g. using FTP, HTTP, email etc.), direct TCP-based management protocol, management protocol via e-mail, and management protocol via HTTP mentioned in section 5 of [RFC2510].

A.4.1.2.1 Basic authenticated scheme

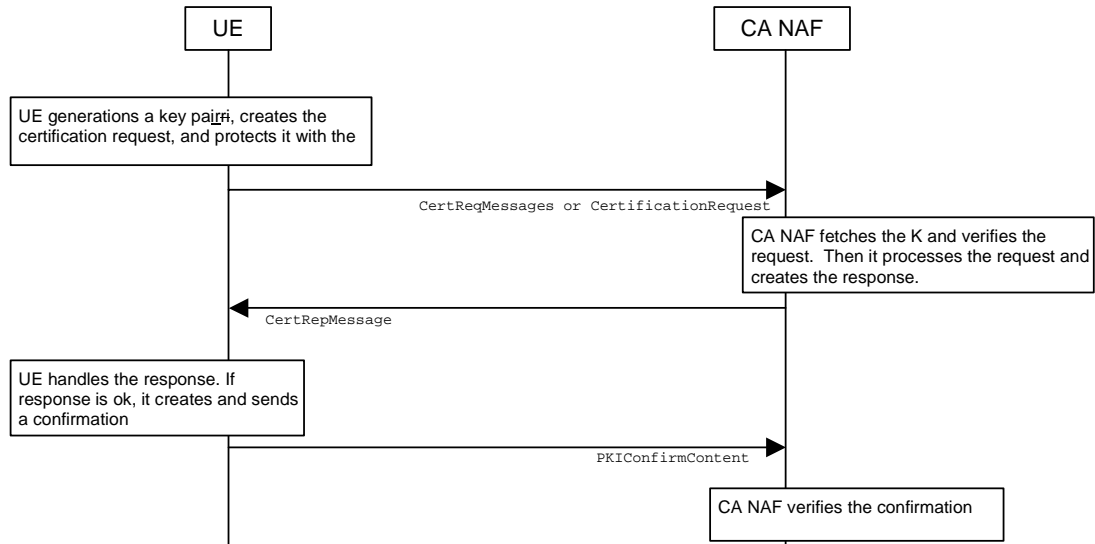

Figure 6: Certificate request using basic authentication scheme of CMP.

The sequence diagram above describes the certificate request and delivery procedure when using CMP and basic authenticated scheme [RFC2510]. The sequence starts with UE generating a key pair, creating the certificate request message format (CRMF) message, inserting it to CertReqMessages message, and integrity protecting this message with the initial authentication key (IAK). The session key K, which has been derived earlier using protocol A, can be used as IAK.

The certificate request message is sent to CA NAF who fetches the corresponding K based on the identifier received in the request. CA NAF verifies the request with the K. If the verification succeeds, the CA NAF processes the request, i.e. generates and signs the certificate and sends the certification response to the UE.

UE verifies the certificate response message with the K. If the message verification is successful, the issued certificate is stored to the device, and UE sends a confirmation message to the CA NAF.

CA NAF verifies the confirmation message. If the verification fails or CA NAF never receives the confirmation message, CA NAF must revoke the newly issued certificate if it has been already published.

A.4.1.2.2 Centralized scheme initiated by the UE

The centralized scheme provides a mechanism where the public/private key pair is generated outside the UE, e.g. by the CA.

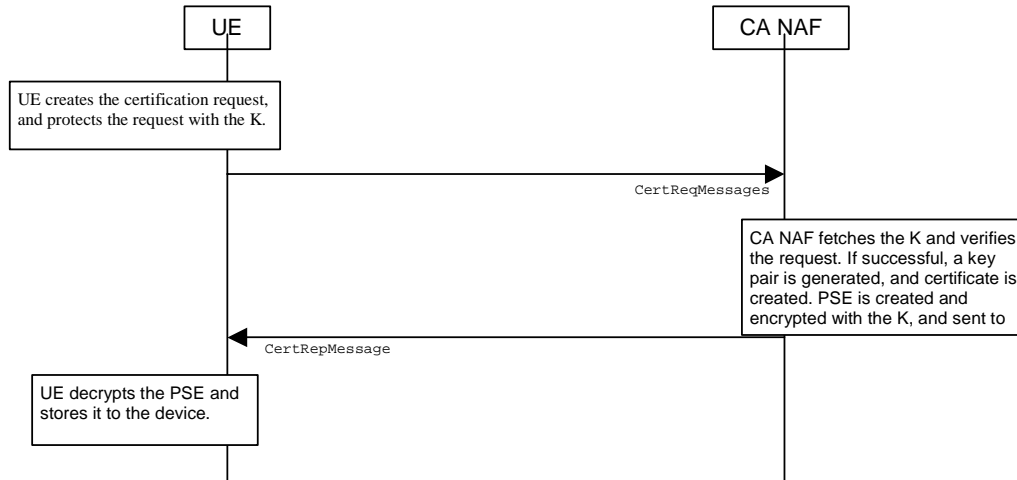

Figure 7: Certificate request using centralized scheme of CMP.

The sequence diagram above describes the delivery mechanism initiated by the UE using CMP in centralized scheme. This scheme is optional in CMP [RFC2510]. The sequence starts with the UE by creating CertReqMessages message with certain parameters, and protecting this message with initial authentication key (IAK). The session key K, which has been derived earlier using protocol A, can be used as IAK.

The certificate request message is sent to CA NAF who fetches the corresponding K based on the identifier received in the request. CA NAF verifies the request with the K. If the verification succeeds, CA NAF processes the request, i.e. generates a key pair, generates and signs the certificate, and sends the certification response containing the Personal Security Environment (PSE) encrypted to the UE. PSE typically contains the generated private key and newly issued certificate with corresponding public key.

UE verifies the certificate response message with the K. If the message verification is successful, the issued PSE is decrypted and stored to the device. A confirmation message is not sent in the centralized scheme.

A.4.2 CA Certificate delivery

A.4.2.1 CA Certificate delivery with HTTP Digest Authentication

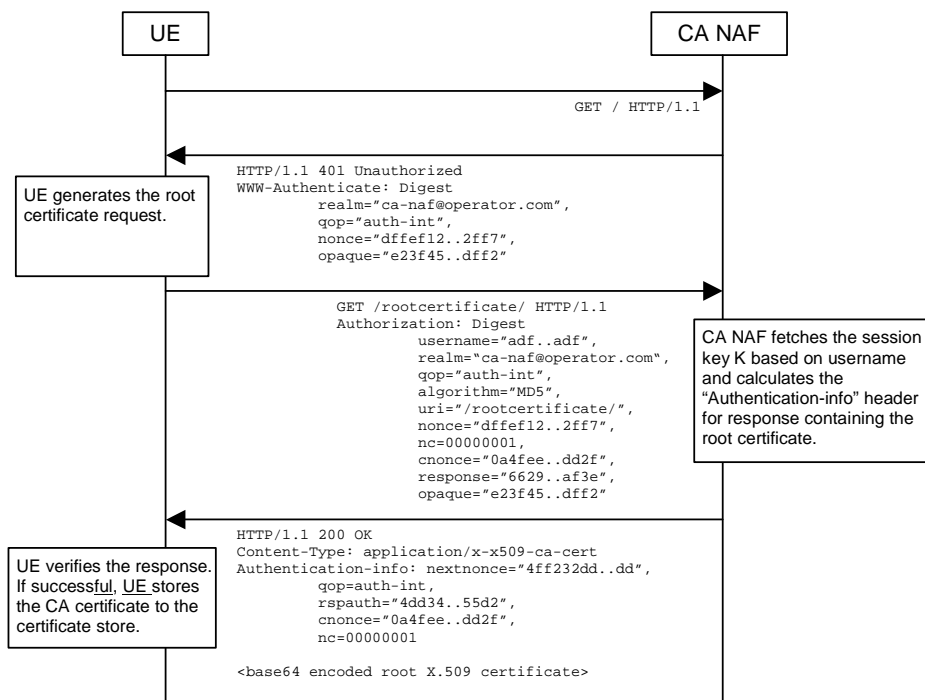

Figure 8: CA certificate delivery with HTTP Digest authentication.

The sequence diagram above describes the CA certificate delivery when using HTTP Digest authentication. The sequence starts with an empty HTTP request to CA NAF. The CA NAF responds with HTTP response code 401 “Unauthorized” which contains a WWW-Authenticate header. The header instructs the UE to use HTTP Digest for authentication.

The UE generates another empty HTTP request for requesting the CA certificate. The Authorization header values are calculated using the identifier and the session key K. The authentication of this HTTP request is not necessary, but it is done in order to follow HTTP Digest authentication specification. Also, the identifier needs to be transported to the CA, i.e. the NAF. A request of subscriber’s certificate is specified in section A.4.1.1.

When CA NAF receives the request, it may verify the Authorization header by fetching the session key K from the bootstrapping server using the identifier. CA NAF will generate a HTTP response containing the CA certificate and use the session key K to authenticate and integrity protect the HTTP response using the Authentication-info header. Essentially, the response could also be other delivery protocol in HTTP format, e.g. PKCS#7 cryptographic message with content type signedData.

When UE receives the new CA certificate, it must validate the Authentication-info header. If validation succeeds, the user is notified that a new CA certificate is taken into use. If user accepts the new CA certificate, it is stored to the local certificate management system and marked as “trusted” CA certificate.

A.4.2.2 CA Certificate delivery with CMP

CMP defines only out-of-band method for delivering CA certificates. CA certificate may be delivered as part of the certificate request, where the response could contain certificates that may be useful to the recipient. It can contain the whole certificate chain (including the CA certificate). The root CA produces a “self-certificate” and also produces a fingerprint of its public key. End entities that acquire this fingerprint securely via some out-of-band means can then verify the CA’s self-certificate and hence the other attributes contained therein.

A.5 Functionality in presence of preloaded, long-lasting key pair

Editor's notes: Based on contribution S3-030037, it was agreed to add this part into the present document for ffs.

In this alternative solution, the UE equipped with a UICC, is previously issued with a pre-loaded, long lasting, public/private key pair from the home network. This phase would occur out of band, and would result in the UE possessing a long lasting key pair stored in the UICC for the purposes of certificate request authentication. Open Mobile Alliance (OMA) group offers standardized solutions by means of WPKI specification [WPKI] and WIM specification [WIM] for the storage and the use of long-lasting key pair. USIM and WIM are examples of applications on the UICC that can deal with the long-lasting keys.

The UE can issue a request for a certificate to the CA, signing the request with the long lasting private key. The certificate request itself could contain a newly generated public key that is to be certified by the CA. This assumes that the new key pair is generated in the UICC. Or it is also possible for the CA to generate the new key pair and send it (protected) to the UICC. Access control security for the pre-loaded long-lasting private key should be at least as good as for access control for USIM.

Two options can be envisaged. Though the public/private key pair is long lasting, the validity of the subscriber certificates issued to the UE could be short-lived. In this case the long lasting public/private key pair is used for PKI applications (e.g. in mobile-commerce) in combination with the short-lived certificates. Alternatively, the long lasting public/private key pair could come with a long-term certificate. The long-term private key would then have a restricted purpose, e.g. only to be used to authenticate subscriber certificate requests. The latter would be used to obtain another, short-lived certificate on a short-lived public/private key pair. It would then be the short-lived keys that could be used for e.g. m-commerce and other 3G PKI applications.

Annex (informative): Generic secure message exchange using HTTP Digest Authentication

B.1 Introduction

Editor's note: This annex describes how HTTP Digest Authentication can be used between UE and any NAF whose protocol B is based on HTTP messaging. It is ffs to determine whether if this annex is going to be part of the final TS.

HTTP Digest Authentication model can also be used as a generic authentication and integrity protection method towards any new NAF. If a new NAF uses BSF-based security association, it could use this generic method to authenticate the UE (and UE authenticate the NAF) and integrity protect any payload being transferred between NAF and UE. As a generic method, it will speed up the specification of new NAFs since the authentication and message integrity protection part of protocol B are taken care of by HTTP Digest Authentication. It will also ease the implementation of BSF-based authentication in NAFs because there would be one well-defined way to do it.

B.2 Generic protocol B description

The sequence diagram in Figure 9 describes the generic secure message exchange with HTTP Digest Authentication. The conversation may take place inside a server-authenticated TLS [RFC2246] tunnel in which case TLS handshake has taken place before step 1.

In step 1, UE sends an empty HTTP request to a NAF. In step 2, NAF responds with HTTP response code 401 "Unauthorized" which contains a WWW-Authenticate header. The header instructs the UE to use HTTP Digest Authentication with a bootstrapped security association. Quality of protection (qop) attribute is set to "auth-int" meaning that the payload of the following HTTP requests and responses should integrity protected. The realm attribute contains two parts. The first part is a constant string "3GPP-bootstrapping" instructing the UE to use a bootstrapped security association. The second part is the DNS name of the NAF.

In step 3, the UE shall verify that the second part of the realm attribute does in fact correspond to the server it is talking to. In particular, if the conversation is taking place inside a server-authenticated TLS tunnel, the UE shall verify that the server name in the server's TLS certificate matches the server name in the realm attribute of the WWW-Authenticate header. The UE generates client-payload containing the message it wants to send to the server. Then it will generate the HTTP request by calculating the Authorization header values using the transaction identifier (base64 encoded) it received from the BSF as username and the session key K (base64 encoded) as the password, and send the request to NAF in step 4.

When NAF receives the request in step 5, it will verify the Authorization header by fetching the session key K from the bootstrapping server using protocol D and the transaction identifier. After successful retrieval, NAF calculates the corresponding digest values using K, and compares the calculated values with the received values in the Authorization header. The NAF shall also verify that the DNS name in the realm attribute matches its own. If the conversation is taking place inside a server-authenticated TLS tunnel, the NAF shall also verify that this DNS name is the same as that of the TLS server. If the verification succeeds, the incoming client-payload request is taken in for further processing. Thereafter, the NAF will generate a HTTP response containing the server-payload it wants to send back to the client in step 6. The NAF may use session key K to integrity protect and authenticate the response.

In step 7, UE receives the response and verifies the Authentication-Info header. If the verification succeeds, the UE can accept the server-payload for further processing.

Additional messages can be exchanged using steps 3 through 7 as many times as is necessary. The following HTTP request and responses must be constructed according to RFC 2617 (e.g., nc parameter must be incremented by one with each new HTTP request made by UE).

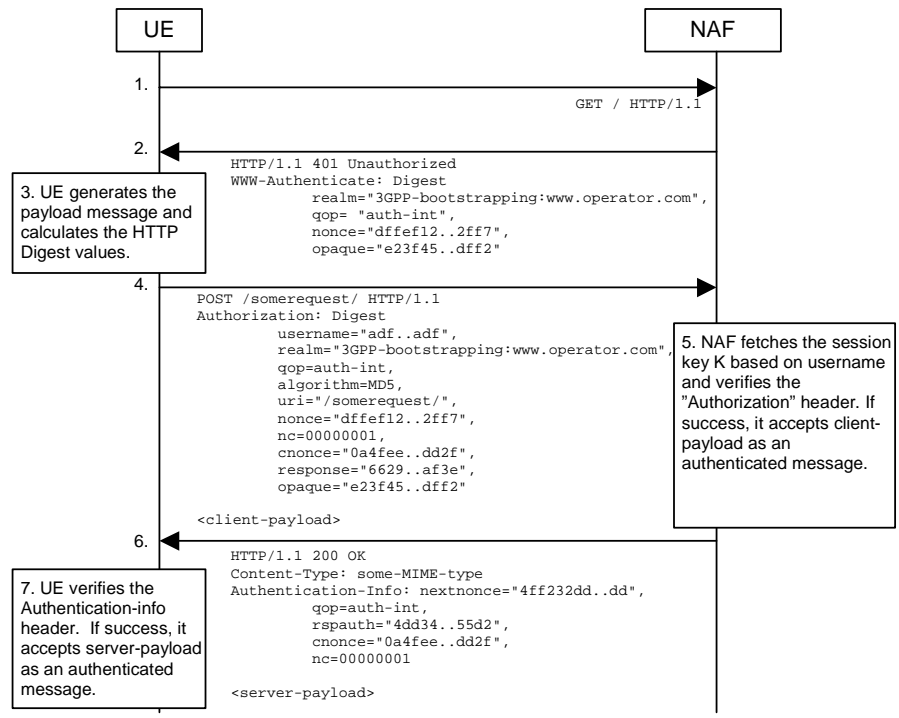

Figure 9. Generic secure message exchange using HTTP Digest Authentication and bootstrapped security association

Annex <X> (informative): Change history

Change history							
Date	TSG #	TSG Doc.	CR	Rev	Subject/Comment	Old	New
2003-02	SA3#27	SA3-030051, SA3-030073			<i>First Draft TS: Bootstrapping of application security using AKA and Support for Subscriber Certificates.</i>		0.1.0
2003-05	SA3#28	S3-030230 S3-030231 S3-030232 S3-030280			<i>Further development of the TS.</i>	0.1.0	0.2.0