

3G CHANGE REQUEST

Please see embedded help file at the bottom of this page for instructions on how to fill in this form correctly.

33.103 CR 006

Current Version: **3.1.0**

3G specification number ↑

↑ CR number as allocated by 3G support team

For submission to TSG **SA3** for approval (only one box should be marked with an X)
list TSG meeting no. here ↑ for information

Form: 3G CR cover sheet, version 1.0 The latest version of this form is available from: <ftp://ftp.3gpp.org/Information/3GCRF-xx.rtf>

Proposed change affects:
(at least one should be marked with an X)

USIM ME UTRAN Core Network

Source: BT **Date:** 2000-Feb-18

Subject: Alignment of integration Guidelines with Security Architecture at S3#10

3G Work item: Security

Category:
(only one category shall be marked with an X)
F Correction
A Corresponds to a correction in a 2G specification
B Addition of feature
C Functional modification of feature
D Editorial modification

Reason for change:
To bring integration Guidelines into line with Security Architecture at S3#10
Removal of window and list options
Removed annex A
Add conversion functions c1 to c5
Add details of AUTS and MACS replaced with MAC-S
Add footnote to clarify the relationship of f8 to UEA etc

Clauses affected:

Other specs affected:
Other 3G core specifications → List of CRs:
Other 2G core specifications → List of CRs:
MS test specifications → List of CRs:
BSS test specifications → List of CRs:
O&M specifications → List of CRs:

Other comments:



<----- double-click here for help and instructions on how to create a CR.

3G TS 33.103 V3.42.0 (~~1999~~2000-402)

**3rd Generation Partnership Project;
Technical Specification Group Services and System Aspects;
3G Security;
Integration Guidelines
3G TS 33.103 V 3.42.0**



The present document has been developed within the 3rd Generation Partnership Project (3GPPTM) and may be further elaborated for the purposes of 3GPP. The present document has not been subject to any approval process by the 3GPP Organisational Partners and shall not be implemented. This Specification is provided for future development work within 3GPP only. The Organisational Partners accept no liability for any use of this Specification. Specifications and reports for implementation of the 3GPPTM system should be obtained via the 3GPP Organisational Partners' Publications Offices.

Reference

DTS/TSGS-_____

Keywords

Security, Authentication and Key Agreement, Security Information
Stored, Location of Security Functions, Parameter Lengths

3GPP

Postal address

3GPP support office address

650 Route des Lucioles - Sophia Antipolis
Valbonne - FRANCE
Tel.: +33 4 92 94 42 00 Fax: +33 4 93 65 47 16

Internet

<http://www.3gpp.org>

Copyright Notification

No part may be reproduced except as authorised by written permission.
The copyright and the foregoing restrictions extend to reproduction in all media.

© 3GPP 1999
All rights reserved.

Contents

1	Scope	4
2	References	4
2.1	Normative references.....	5
3	Definitions, symbols and abbreviations	5
3.1	Definitions	5
3.2	Symbols	6
3.3	Abbreviations.....	6
4	Access link security	8
4.1	Functional network architecture.....	8
4.2	User services identity module	9
4.2.1	Enhanced User Identity Confidentiality (EUIC _{USIM}).....	9
4.2.2	Authentication and key agreement (AKA _{USIM}).....	10
4.3	User equipment.....	14
4.3.1	User identity confidentiality (UIC _{UE}).....	14
4.3.2	Data confidentiality (DC _{UE})	15
4.3.3	Data integrity (DI _{UE})	17
4.4	Radio network controller	18
4.4.1	Data confidentiality (DC _{rnc})	18
4.4.2	Data integrity (DI _{rnc})	20
4.5	SN (or MSC/VLR or SGSN)	21
4.5.1	User identity confidentiality (UIC _{SN}).....	21
4.5.2	Authentication and key agreement (AKA _{SN}).....	22
4.6	Home location register / Authentication centre.....	23
4.6.1	Enhanced User Identity Confidentiality (EUIC _{HE}).....	23
4.6.2	Authentication and key agreement (AKA _{he}).....	24
5	Provider domain security	27
5.1	Functional security architecture	27
5.2	Key Authentication Centre.....	28
5.3	Core network entities	29
6	Network Wide Confidentiality	30
7	Annex B (informative): Change history	37
	History	38

Foreword

This document has been drafted by 3GPP TSG-SA WG 3, i.e., the Workgroup devoted to “Security” issues, within the Technical Specification Group devoted to “System Aspects”.

1 Scope

This technical specification defines how elements of the 3G-security architecture are to be integrated into the following entities of the system architecture.

- Home Environment Authentication Centre (HE/AuC)
- Serving Network Visited Location Register (SN/VLR/VLR/SGSN)
- Radio Network Controller (RNC)
- Mobile station User Identity Module (UIM)
- Mobile Equipment (ME)

This specification is derived from 3G "Security architecture". [1]

The structure of this technical specification is a series of tables, which describe the security information and cryptographic functions to be stored in the above entities of the 3G system.

For security information, this is in terms of multiplicity, lifetime, parameter length and whether mandatory or optional.

For the cryptographic functions, the tables also include an indication of whether the implementation needs to be standardised or can be proprietary.

The equivalent information for the alternative Temporary Key proposal is included in an appendix to this document.

2 References

References may be made to:

- a) Specific versions of publications (identified by date of publication, edition number, version number, etc.), in which case, subsequent revisions to the referenced document do not apply; or
- b) All versions up to and including the identified version (identified by "up to and including" before the version identity); or
- c) All versions subsequent to and including the identified version (identified by "onwards" following the version identity); or
- d) Publications without mention of a specific version, in which case the latest version applies.

A non-specific reference to an ETS shall also be taken to refer to later versions published as an EN with the same number.

2.1 Normative references

- [1] 3rd Generation Partnership Project; Technical Specification Group Services and System Aspects; 3G Security; 3G Security Architecture 3G TS 33.102

3 Definitions, symbols and abbreviations

3.1 Definitions

For the purposes of the present document, the following definitions apply:

Confidentiality: ~~The property that information is not made available or disclosed to unauthorised individuals, entities or processes.~~

Data integrity: ~~The property that data has not been altered in an unauthorised manner.~~

Data origin authentication: ~~The corroboration that the source of data received is as claimed.~~

Entity authentication: ~~The provision of assurance of the claimed identity of an entity.~~

Key freshness: ~~A key is fresh if it can be guaranteed to be new, as opposed to an old key being reused through actions of either an adversary or authorised party.~~

Confidentiality: The property that information is not made available or disclosed to unauthorised individuals, entities or processes.

Data integrity: The property that data has not been altered in an unauthorised manner.

Data origin authentication: The corroboration that the source of data received is as claimed.

Entity authentication: The provision of assurance of the claimed identity of an entity.

Key freshness: A key is fresh if it can be guaranteed to be new, as opposed to an old key being reused through actions of either an adversary or authorised party.

USIM – User Services Identity Module. In a security context, this module is responsible for performing UMTS subscriber and network authentication and key agreement. It should also be capable of performing GSM authentication and key agreement to enable the subscriber to roam easily into a GSM Radio Access Network.

SIM – GSM Subscriber Identity Module. In a security context, this module is responsible for performing GSM subscriber authentication and key agreement. This module is **not** capable of handling UMTS authentication nor storing UMTS style keys.

UMTS Entity authentication and key agreement: Entity authentication according to this specification.

GSM Entity authentication and key agreement: Entity authentication according to TS ETSI GSM 03.20

User access module: either a USIM or a SIM

Mobile station, user: the combination of user equipment and a user access module.

UMTS subscriber: a mobile station that consists of user equipment with a USIM inserted.

GSM subscriber: a mobile station that consists of user equipment with a SIM inserted.

UMTS security context: a state that is established between a user and a serving network domain as a result of the execution of UMTS AKA. At both ends "UMTS security context data" is stored, that consists at least of the UMTS cipher/integrity keys CK and IK and the key set identifier KSI.

GSM security context: a state that is established between a user and a serving network domain usually as a result of the execution of GSM AKA. At both ends "GSM security context data" is stored, that consists at least of the GSM cipher key Kc and the cipher key sequence number CKSN.

Quintet, UMTS authentication vector: temporary authentication data that enables an MSC/VLR or SGSN to engage in UMTS AKA with a particular user. A quintet consists of five elements: a) a network challenge RAND, b) an expected user response XRES, c) a cipher key CK, d) an integrity key IK and e) a network authentication token AUTN.

Triplet, GSM authentication vector: temporary authentication data that enables an MSC/VLR or SGSN to engage in GSM AKA with a particular user. A triplet consists of three elements: a) a network challenge RAND, b) an expected user response SRES and c) a cipher key Kc.

Authentication vector: either a quintet or a triplet.

Temporary authentication data: either UMTS or GSM security context data or UMTS or GSM authentication vectors.

3.2 Symbols

For the purposes of the present document, the following symbols apply:

	Concatenation
\oplus	Exclusive or
f1	Message authentication function used to compute MAC
f1*	Message authentication function used to compute MAC_S
f2	Message authentication function used to compute RES and XRES
f3	Key generating function used to compute CK
f4	Key generating function used to compute IK
f5	Key generating function used to compute AK
f6	Encryption function used to encrypt the IMSI
f7	Decryption function used to decrypt the IMSI (=f6 ⁻¹)
f8	Integrity algorithm
f9	Confidentiality algorithm
K	Long-term secret key shared between the USIM and the AuC

3.3 Abbreviations

For the purposes of the present document, the following abbreviations apply:

3GMS	Third Generation Mobile Communication System
AK	Anonymity Key
AUTN	Authentication Token
AUTS	Authentication Token for Synchronisation
AV	Authentication Vector
CK	Cipher Key
CS	Circuit Switched
$D_{SK(X)}(\text{data})$	Decryption of "data" with Secret Key of X used for signing
$E_{K(SX,Y)(i)}(\text{data})$	Encryption of "data" with Symmetric Session Key #i for sending data from X to Y
$E_{PK(X)}(\text{data})$	Encryption of "data" with Public Key of X used for encryption
ECK	Network Wide Cipher Key
ECKC	Network Cipher Key Component for UE
ECKCpeer	Network Cipher Key Component for peer UE
EMSI	Encrypted Subscriber identity
GK	Group Key
GI	Group Identifier
Hash(data)	The result of applying a collision-resistant one-way hash function to "data"
HE	Home Environment
HLR	Home Location Register
IK	Integrity Key
IMSI	International Mobile Subscriber Identity
IV	Initialisation Vector
KAC _X	Key Administration Centre of Network X
$K_{SXY}(i)$	Symmetric Session Key #i for sending data from X to Y
KSI	Key Set Identifier
KSS	Key Stream Segment

<u>LAI</u>	<u>Location Area Identity</u>
<u>MAP</u>	<u>Mobile Application Part</u>
<u>MAC</u>	<u>The message authentication code included in AUTN, computed using f1</u>
<u>MACS</u>	<u>The message authentication code included in AUTS, computed using f1*</u>
<u>MAC-I</u>	<u>Message authentication code for data integrity</u>
<u>MS</u>	<u>Mobile Station</u>
<u>MSC</u>	<u>Mobile Services Switching Centre</u>
<u>MT</u>	<u>Mobile Termination</u>
<u>NE_x</u>	<u>Network Element of Network X</u>
<u>PS</u>	<u>Packet Switched</u>
<u>RAND</u>	<u>Random challenge</u>
<u>RAND_{ms}</u>	<u>Random value stored on MS received during user authentication request</u>
<u>RND_x</u>	<u>Unpredictable Random Value generated by X</u>
<u>SEQ</u>	<u>Sequence number</u>
<u>SEQ_{UIC}</u>	<u>Sequence number</u>
<u>SN</u>	<u>Serving Network</u>
<u>TE</u>	<u>Terminal Equipment</u>
<u>Text1</u>	<u>Optional Data Field</u>
<u>Text2</u>	<u>Optional Data Field</u>
<u>Text3</u>	<u>Public Key algorithm identifier and Public Key Version Number (eventually included in Public Key Certificate)</u>
<u>TMSI</u>	<u>Temporary Mobile Subscriber Identity</u>
<u>TVP</u>	<u>Time Variant Parameter</u>
<u>UEA</u>	<u>UMTS Encryption Algorithm</u>
<u>UIA</u>	<u>UMTS Integrity Algorithm</u>
<u>UN</u>	<u>User Name</u>
<u>USIM</u>	<u>User Services Identity Module</u>
<u>VLR</u>	<u>Visited Location Register</u>
<u>X</u>	<u>Network Identifier</u>
<u>XMAC</u>	<u>Expected message authentication code for user authentication</u>
<u>XMAC-I</u>	<u>Expected message authentication code for data integrity</u>
<u>XRES</u>	<u>Expected Response</u>
<u>XUR</u>	<u>Expected User Response</u>
<u>Y</u>	<u>Network Identifier</u>
<u>AK</u>	<u>Anonymity Key</u>
<u>AKA</u>	<u>Authentication and key agreement</u>
<u>AMF</u>	<u>Authentication management field</u>
<u>AUTN</u>	<u>Authentication Token</u>
<u>AV</u>	<u>Authentication Vector</u>
<u>CK</u>	<u>Cipher Key</u>
<u>CKSN</u>	<u>Cipher key sequence number</u>
<u>CS</u>	<u>Circuit Switched</u>
<u>D_{SK(X)}(data)</u>	<u>Decryption of "data" with Secret Key of X used for signing</u>
<u>E_{KSXY(i)}(data)</u>	<u>Encryption of "data" with Symmetric Session Key #i for sending data from X to Y</u>
<u>E_{PK(X)}(data)</u>	<u>Encryption of "data" with Public Key of X used for encryption</u>
<u>Hash(data)</u>	<u>The result of applying a collision-resistant one-way hash-function to "data"</u>
<u>HE</u>	<u>Home Environment</u>
<u>HLR</u>	<u>Home Location Register</u>
<u>IK</u>	<u>Integrity Key</u>
<u>IMSI</u>	<u>International Mobile Subscriber Identity</u>
<u>IV</u>	<u>Initialisation Vector</u>
<u>KAC_x</u>	<u>Key Administration Centre of Network X</u>
<u>KS_{XY(i)}</u>	<u>Symmetric Session Key #i for sending data from X to Y</u>
<u>KSI</u>	<u>Key Set Identifier</u>
<u>KSS</u>	<u>Key Stream Segment</u>
<u>LAI</u>	<u>Location Area Identity</u>
<u>MAP</u>	<u>Mobile Application Part</u>
<u>MAC</u>	<u>Message Authentication Code</u>
<u>MAC-A</u>	<u>The message authentication code included in AUTN, computed using f1</u>
<u>MS</u>	<u>Mobile Station</u>
<u>MSC</u>	<u>Mobile Services Switching Centre</u>
<u>MT</u>	<u>Mobile Termination</u>
<u>NE_x</u>	<u>Network Element of Network X</u>
<u>PS</u>	<u>Packet Switched</u>

<u>P-TMSI</u>	<u>Packet-TMSI</u>
<u>Q</u>	<u>Quintet, UMTS authentication vector</u>
<u>RAI</u>	<u>Routing Area Identifier</u>
<u>RAND</u>	<u>Random challenge</u>
<u>RND_X</u>	<u>Unpredictable Random Value generated by X</u>
<u>SN</u>	<u>Sequence number</u>
<u>SN_{UIC}</u>	<u>Sequence number user for enhanced user identity confidentiality</u>
<u>SN_{HE}</u>	<u>Sequence number counter maintained in the HLR/AuC</u>
<u>SN_{MS}</u>	<u>Sequence number counter maintained in the USIM</u>
<u>SGSN</u>	<u>Serving GPRS Support Node</u>
<u>SIM</u>	<u>(GSM) Subscriber Identity Module</u>
<u>SN</u>	<u>Serving Network</u>
<u>T</u>	<u>Triplet, GSM authentication vector</u>
<u>TE</u>	<u>Terminal Equipment</u>
<u>Text1</u>	<u>Optional Data Field</u>
<u>Text2</u>	<u>Optional Data Field</u>
<u>Text3</u>	<u>Public Key algorithm identifier and Public Key Version Number (eventually included in Public Key Certificate)</u>
<u>TMSI</u>	<u>Temporary Mobile Subscriber Identity</u>
<u>TTP</u>	<u>Trusted Third Party</u>
<u>UE</u>	<u>User equipment</u>
<u>UEA</u>	<u>UMTS Encryption Algorithm</u>
<u>UIA</u>	<u>UMTS Integrity Algorithm</u>
<u>USIM</u>	<u>User Services Identity Module</u>
<u>VLR</u>	<u>Visitor Location Register</u>
<u>X</u>	<u>Network Identifier</u>
<u>XRES</u>	<u>Expected Response</u>
<u>Y</u>	<u>Network Identifier</u>

4 Access link security

4.1 Functional network architecture

Figure 1 shows the functional security architecture of UMTS.

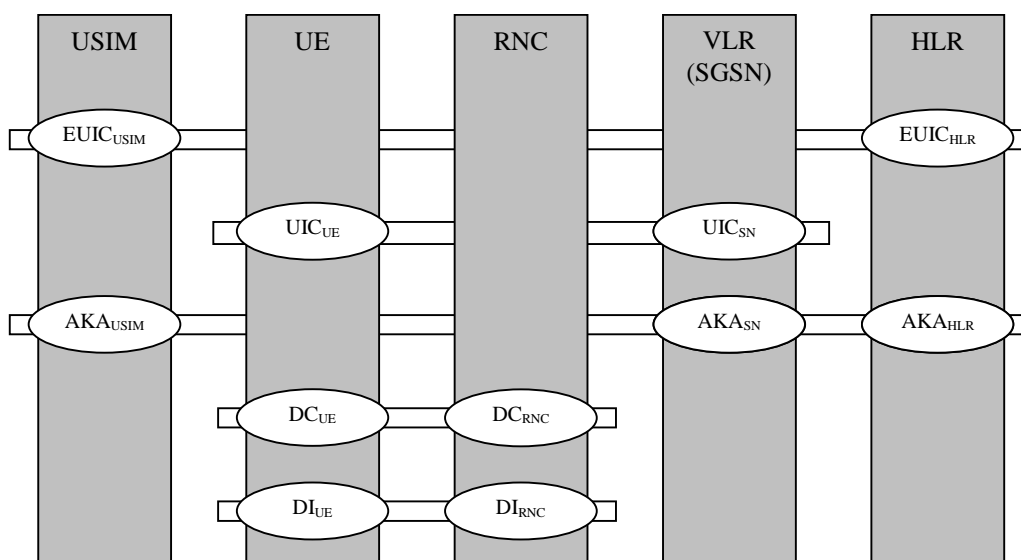

Figure 1: UMTS functional security architecture

The vertical bars represent the network elements:

In the user domain:

USIM (User Service Identity Module): an access module issued by a HE to a user;

UE (User Equipment);

In the serving network (SN) domain:

RNC (Radio Network Controller);

VLR (Visited Location Register), also the SGSN;

In the home environment (HE) domain:

HLR/AuC.

The horizontal lines represent the security mechanisms:

EUIC: mechanism for enhanced user identity confidentiality (optional, between user and HE);

UIC: conventional mechanism for user identity confidentiality (between user and serving network);

AKA: the mechanism for authentication and key agreement, including the functionality to trigger a re-authentication by the user, i.e., to control the access key pair lifetime;

DC: the mechanism for data confidentiality of user and signalling data;

DI: the mechanism for data integrity of signalling data.

DEC: the mechanism for network-wide data confidentiality

In the remaining section of this specification we describe what data elements and functions need to be implemented in each of the above network elements for each of the above mechanisms and functions.

4.2 User services identity module

4.2.1 Enhanced User Identity Confidentiality (EUIC_{USIM})

For UMTS users with EUIC, the USIM has to store additional data and have additional functions implemented to encrypt the permanent user identity (IMSI). We describe the requirements as regards data storage and algorithm implementation for an example mechanism in annex B of 3G TS 33.102.

The following data elements need to be stored on the USIM:

- SQN_{UIC}: a counter that is equal to the highest SQN_{UIC} generated and sent by the USIM to the HE/HLR/AuC;
- GK: the group key used to encrypt the IMSI and SQN_{UIC};
- GI: a group identifier that identifies the group the user refers to as well as the GK;
- HLR-id consists of the first 3 digits of MSIN as a subaddress of HLR the user is related to;

Table 1: USIM – Enhanced User Identity Confidentiality – Data elements

Symbol	Description	Multiplicity	Lifetime	Length	Mandatory / Optional
GK	Group key	1 per user group the user belongs to	Permanent	128 ¹ bits	Optional

□ _____

¹ the table entry is for the example secret key mechanism given in annex B of 33.102

SN _{UIC}	Counter	1 per user	Updated when protocol for EUIC is executed	32 bits	Optional
GI	Group Identity	1 per user	Permanent	32 bits	Optional
HLR-id	Subaddress of entity which can perform decryption (first 3 digits of MSIN)	1 per user	Permanent	3 digits	Optional

The following cryptographic functions need to be implemented in the HLR/AuC:

- f6: the user identity encryption function.

For a summary of the data elements and cryptographic function of the EUIC_{HE} function see Table 2.

Table 2: USIM- Enhanced User Identity Confidentiality – Cryptographic functions

Symbol	Description	Multiplicity	Lifetime	Standardised / Proprietary	Mandatory / Optional
f6	User identity encryption function	1	Permanent	Proprietary	Optional

4.2.2 Authentication and key agreement (AKA_{USIM})

The USIM shall support the UMTS mechanism for authentication and key agreement described in 6.3 of 3G TS 33.102.

The following data elements need to be stored on the USIM:

- a) K: a permanent secret key;
- b) SN_{MS}: a counter that is equal to the highest sequence number SN in an AUTN parameter accepted by the user.
~~For the WINDOW option: an array of Boolean values over the interval [SN_{MS} - w, SN_{MS}), that indicate whether the USIM has accepted a certain sequence number in an AUTN parameter.~~
- b) ~~For the LIST option: an ordered list of the highest values that the USIM has received~~
- c) RAND_{MS}: the random challenge which was received together with the last AUTN parameter accepted by the user. It is used to calculate the re-synchronisation message together with the highest accepted sequence number (SN_{MS}).
- d) KSI: key set identifier.
- e) THRESHOLD_C: a threshold defined by the HE to trigger re-authentication and to control the cipher key lifetime;
- f) CK The access link cipher key established as part of authentication
- g) IK The access link integrity key established as part of authentication
- h) HFN_{MS}: Stored Hyper Frame Number provides the Initialisation value for most significant part of COUNT-C and COUNT-I. The least significant part is obtained from the RRC sequence number.
- i) AMF: A 16-bit field used Authentication Management. The use and format are unspecified in the architecture but examples are given in an informative annex.
- j) The GSM authentication parameter and GSM cipher key derived from the UMTS to GSM conversion functions

Table 3 provides an overview of the data elements stored on the USIM to support authentication and key agreement.

Table 3: USIM – Authentication and key agreement – Data elements

Symbol	Description	Multiplicity	Lifetime	Length	Mandatory / Optional
K	Permanent secret key	1 ²	Permanent	128 bits	Mandatory
SQN _{MS}	Sequence number counter	1	Updated when AKA protocol is executed	32-64 bits	Mandatory
RAND _{MS}	Random challenge received by the user.	1	Updated when AKA protocol is executed	128 bits	Mandatory
KSI	Key set identifier	1	Updated when AKA protocol is executed	3 bits	Mandatory
THRESHOLD _C	Threshold value for ciphering	1	Permanent	32 bits	Optional
CK	Cipher key	1	Updated when AKA protocol is executed	128 bits	Mandatory
IK	Integrity key	1	Updated when AKA protocol is executed	128 bits	Mandatory
HFN _{MS}	Initialisation value for most significant part for COUNT-C and for COUNT-I	1	Updated when connection is released	25 bits	Mandatory
AMF	Authentication Management Field (indicates the algorithm and key in use)	1	Updated when AKA protocol is executed	16 bits	Mandatory
RAND _G	GSM authentication parameter from conversion function	1	Updated when GSM AKA or UMTS AKA protocol is executed	As for GSM	Optional
SRES	GSM authentication parameter from conversion function	1	Updated when GSM AKA or UMTS AKA protocol is executed	As for GSM	Optional
Kc	GSM cipher Key	1	Updated when GSM AKA or UMTS AKA protocol is executed	As for GSM	Optional

The following cryptographic functions need to be implemented on the USIM:

- f1: a message authentication function for network authentication;
- f1*: a message authentication function for support to re-synchronisation;

□ _____

² HE policy may dictate more than one, the active key signalled using the AMF function

- f2: a message authentication function for user authentication;
- f3: a key generating function to derive the cipher key;
- f4: a key generating function to derive the integrity key;
- f5: a key generating function to derive the anonymity key.
- ~~C1 to C2: Conversion functions for interoperation with GSM (UMTS RES → GSM RES and UMTS CK IK → GSM Ke)~~
- c2: Conversion function for interoperation with GSM from XRES (UMTS) to SRES (GSM)
- c3 Conversion function for interoperation with GSM from Ck and IK (UMTS) to Kc (GSM)

Figure 2 provides an overview of the data integrity, data origin authentication and verification of the freshness by the USIM of the RAND and AUTN parameters received from the SN/VLR/SGSN, and the derivation of the response RES, the cipher key CK and the integrity key IK. Note that the anonymity Key (AK) is optional

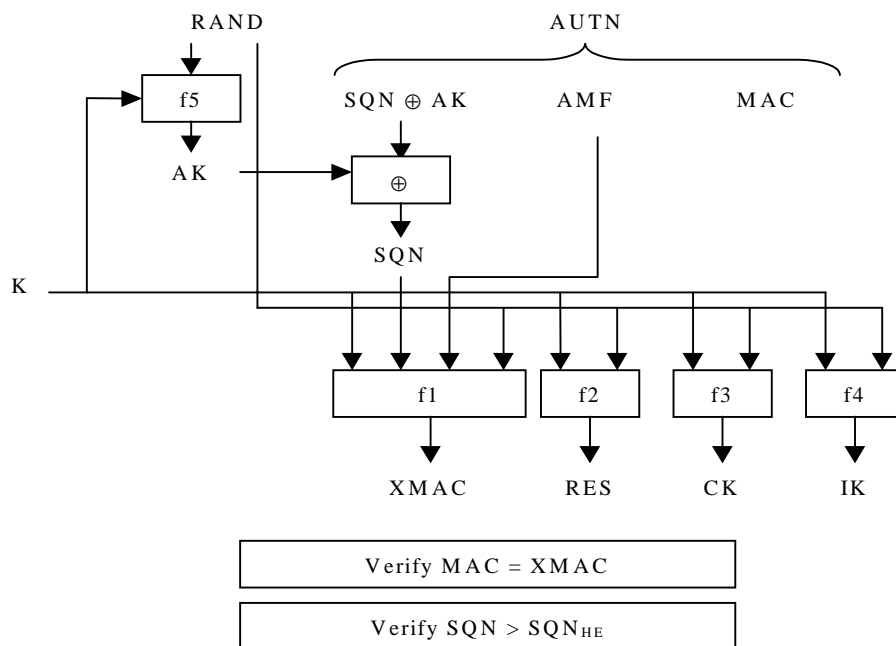

Figure 2: User authentication function in the USIM

Figure 3 provides an overview of the generation in the USIM of a token for re-synchronisation AUTS.

- a) The USIM computes $MAC-S = f1_K(SQN_{MS} || RAND || AMF^*)$, whereby AMF^* is a default value for AMF used in re-synchronisation.
- b) If SQN_{MS} is to be concealed with an anonymity key AK, the USIM computes $AK = f5_K(MAC-S || 0...0)$, whereby $MAC-S$ forms the 12 most significant octets and 32 zeros form the 4 least significant octets of the required 16 octet input parameter, and the concealed counter value is then computed as $SQN_{MS} \oplus AK$.
- c) The re-synchronisation token is constructed as $AUTS = SQN_{MS} [\oplus AK] || MAC-S$.

Upon receipt of an indication of synchronisation failure and a (AUTS, RAND) pair, the HLR/AuC may perform the following cryptographic functions:

- a) If SQN_{MS} is concealed with an anonymity key AK , the HLR/AuC computes $AK = f5_K(MAC-S \parallel 0\dots0)$, whereby $MAC-S$ forms the 12 most significant octets and 32 zeros form the 4 least significant octets of the required 16 octet input parameter and retrieves the unconcealed counter value as $SQN_{MS} = (SQN_{MS} \oplus AK) \text{ xor } AK$.
- b) If SQN generated from SQN_{HF} would not be acceptable, then the HLR/AuC computes $XMAC-S = f1^*_K(SQN_{MS} \parallel RAND \parallel AMF^*)$, whereby AMF^* is a default value for AMF used in re-synchronisation.

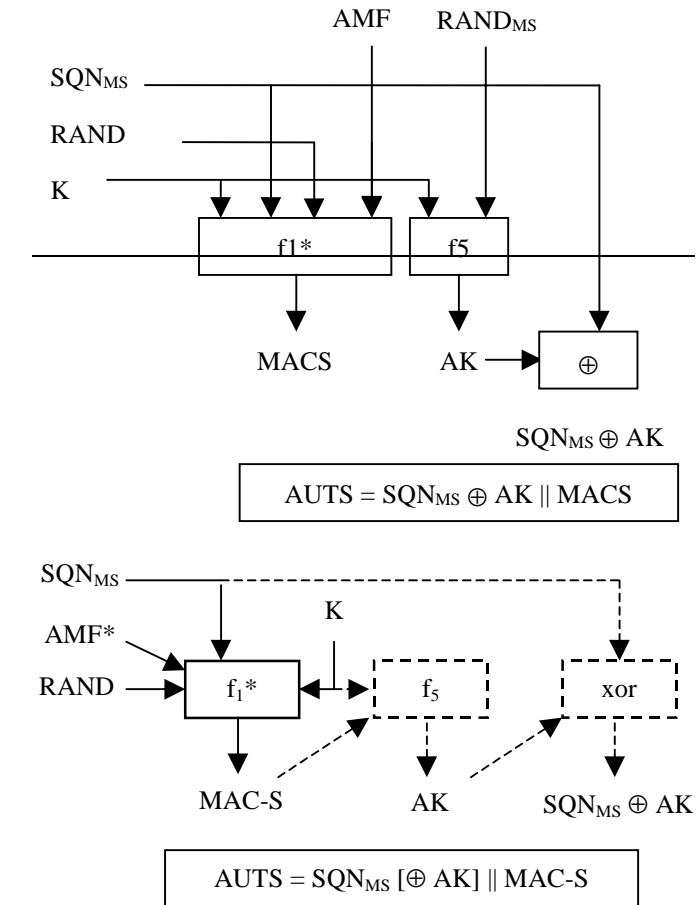

Figure 3: Generation of a token for re-synchronisation $AUTS^3$

Table 4 provides a summary of the cryptographic functions implemented on the USIM to support authentication and key agreement.

Table 4: USIM – Authentication and key agreement – Cryptographic functions

Symbol	Description	Multiplicity	Lifetime	Standardised / Proprietary	Mandatory / Optional
f1	Network authentication function	1	Permanent	Proprietary	Mandatory

□ _____

³ The lengths of $AUTS$ and $MAC-S$ are specified in table 22

f1*	Message authentication function for synchronisation	1	Permanent	Proprietary	Mandatory
f2	User authentication function	1	Permanent	Proprietary	Mandatory
f3	Cipher key generating function	1	Permanent	Proprietary	Mandatory
f4	Integrity key generating function	1	Permanent	Proprietary	Mandatory
f5	Anonymity key generating function	1	Permanent	Proprietary	Optional
c1 to c2 <u>c2 and c3</u>	Conversion functions for interoperation with GSM	1 of each	Permanent	Standard	Optional

4.3 User equipment

4.3.1 User identity confidentiality (UIC_{UE})

The UE shall support the UMTS conventional mechanism for user identity confidentiality described in 6.1 of 3G TS 33.102.

The UE shall store the following data elements:

- TMUI-CS: a temporary identity allocated by the CS core network;
- LAI: a location area identifier;
- the TMUI-PS: a temporary identity allocated by the PS core network;
- the RAI: a routing area identifier

Table 5: UE – User Identity Confidentiality – Data elements

Symbol	Description	Multiplicity	Lifetime	Length	Mandatory / Optional
TMUI-CS	Temporary user identity	1 per user	Updated when TMUI allocation protocol is executed by CS core network	As per GSM TMSI	Mandatory
LAI	Location area identity	1 per user	Updated when TMUI allocation protocol is executed by CS core network		Mandatory
TMUI-PS	Temporary user identity	1 per user	Updated when TMUI allocation protocol is executed by PS core network		Mandatory
RAI	Routing area identity	1 per user	Updated when TMUI allocation protocol is executed by PS core network		Mandatory

4.3.2 Data confidentiality (DC_{UE})

The UE shall support the UMTS mechanism for confidentiality of user and signalling data described in 6.6 of 3G TS 33.102.

The UE shall store the following data elements:

- a) UEA-MS: the ciphering capabilities of the UE;
- b) CK: the cipher key;
- c) UEA: the selected ciphering function;

In addition, when in dedicated mode:

- d) COUNT- C_{UP} : a time varying parameter for synchronisation of ciphering for the uplink;
- e) COUNT- C_{DOWN} : a time varying parameter for synchronisation of ciphering for the downlink;
- f) BEARER: a logical channel identifier.
- g) DIRECTION: An indication of the direction of transmission uplink or downlink to ensure a different cipher is applied

Table 6: provides an overview of the data elements stored on the UE to support the mechanism for data confidentiality:

Table 6: UE – Data Confidentiality – Data elements

Symbol	Description	Multiplicity	Lifetime	Length	Mandatory / Optional
UEA-MS	Ciphering capabilities of the UE	1 per UE	Permanent	16 bits	Mandatory
CK	Cipher key	1 per mode	Updated at execution of AKA protocol	128 bits	Mandatory
UEA	Selected ciphering capability	1 per UE	Updated at connection establishment	4 bits	Mandatory
COUNT- C_{UP}	Time varying parameter for synchronisation of ciphering	1 per logical channel	Lifetime of a logical channel	32 bits	Mandatory
COUNT- C_{DOWN}	Time varying parameter for synchronisation of ciphering	1 per logical channel	Lifetime of a logical channel	32 bits	Mandatory
BEARER	Logical channel identifier	1 per logical channel	Lifetime of a logical channel	8 bits	Mandatory
DIRECTION	An indication of the direction of transmission uplink or downlink	1 per logical channel	Lifetime of a logical channel	1 bit	Mandatory

The following cryptographic functions shall be implemented on the UE:

- f8: access link encryption function.⁴
- c4: Conversion function for interoperation with GSM from Kc (GSM) to CK (UMTS)
- Table 7: provides an overview of the cryptographic functions implemented on the UE to support the mechanism for data confidentiality.

□ _____

⁴ The security architecture TS 33.102 refers to UEA, f8 is a specific implementation of UEA as defined in Cryptographic algorithm requirements TS 33.105

Table 7: UE – ~~Enhanced User Identity Confidentiality~~Data Confidentiality – Cryptographic functions

Symbol	Description	Multiplicity	Lifetime	Standardised / Proprietary	Mandatory / Optional
f8	Access link encryption function	1-16	Permanent	Standardised	One at least is mandatory
<u>c4</u>	<u>Conversion function for interoperation with GSM</u>	<u>1</u>	<u>Permanent</u>	<u>Standardised</u>	<u>Optional</u>

4.3.3 Data integrity (DI_{UE})

The UE shall support the UMTS mechanism for integrity of signalling data described in 6.4 of 3G TS 33.102.

The UE shall store the following data elements:

- a) UIA-MS: the integrity capabilities of the UE;

In addition, when in dedicated mode:

- b) UIA: the selected UMTS integrity algorithm;
- c) IK: an integrity key;
- d) COUNT-I_{UP}: a time varying parameter for synchronisation of data integrity in the uplink direction;
- e) COUNT-I_{DOWN}: a time varying parameter for synchronisation of data integrity in the downlink direction;
- h) DIRECTION: An indication of the direction of transmission uplink or downlink to ensure a different cipher is applied
- f) FRESH: a network challenge;

Table 8: provides an overview of the data elements stored on the UE to support the mechanism for data confidentiality:

Table 8: UE – Data Integrity – Data elements

Symbol	Description	Multiplicity	Lifetime	Length	Mandatory / Optional
UIA-MS	Ciphering capabilities of the UE	1 per UE	Permanent	16 bits	Mandatory
UIA	Selected ciphering capability	1 per UE	Updated at connection establishment	4 bits	Mandatory
IK	Integrity key	1 per mode	Updated by the execution of the AKA protocol	128 bits	Mandatory
DIRECTION	An indication of the direction of transmission uplink or downlink	1 per logical channel	Lifetime of a logical channel	1 bit	Mandatory
COUNT-I _{UP}	Synchronisation value	1	Lifetime of a connection	32 bits	Mandatory
COUNT-I _{DOWN}	Synchronisation value	1	Lifetime of a connection	32 bits	Mandatory
FRESH	Network challenge	1	Lifetime of a connection	32 bits	Mandatory
MAC-I XMAC-I	Message authentication code	1	Updated by the execution of the AKA protocol	32 bits	Mandatory

The following cryptographic functions shall be implemented on the UE:

- f9: access link integrity function.⁵
- c5: Conversion function for interoperation with GSM K_c (GSM) > IK (UMTS)

Table 9 provides an overview of the cryptographic functions implemented in the UE:

Table 9: UE – Data Integrity – Cryptographic functions

Symbol	Description	Multiplicity	Lifetime	Standardised / Proprietary	Mandatory / Optional
f9	Access link data integrity function	1-16	Permanent	Standardised	One at least is mandatory
<u>c5</u>	<u>Conversion function for interoperation with GSM</u>	<u>1</u>	<u>Permanent</u>	<u>Standardised</u>	<u>Optional</u>

4.4 Radio network controller

4.4.1 Data confidentiality (DC_{rnc})

The RNC shall support the UMTS mechanism for data confidentiality of user and signalling data described in 6.6 of 3G TS 33.102.

The RNC shall store the following data elements:

- a) UEA-RNC: the ciphering capabilities of the RNC;

In addition, when in dedicated mode:

- b) UEA: the selected ciphering function;
- c) CK: the cipher key;
- d) COUNT- C_{UP} : a time varying parameter for synchronisation of ciphering for the uplink;
- e) COUNT- C_{DOWN} : a time varying parameter for synchronisation of ciphering for the downlink;
- f) DIRECTION: An indication of the direction of transmission uplink or downlink to ensure a different cipher is applied
- g) BEARER: a logical channel identifier.

Table 10 provides an overview of the data elements stored in the RNC to support the mechanism for data confidentiality:

□ _____

⁵ The security architecture TS 33.102 refers to UIA . f9 is a specific implementation of UIA as defined in Cryptographic algorithm requirements TS 33.105

Table 10: RNC – Data Confidentiality – Data elements

Symbol	Description	Multiplicity	Lifetime	Length	Mandatory / Optional
UEA-RNC	Ciphering capabilities of the UE	1	Permanent	16 bits	Mandatory
UEA	Selected ciphering capability	1 per user and per mode	Updated at connection establishment	4 bits	Mandatory
CK	Cipher key	1 per user and per mode	Updated at connection establishment	128 bits	Mandatory
COUNT-C _{UP}	Time varying parameter for synchronisation of ciphering	1 per logical channel	Lifetime of a logical channel	32 bits	Mandatory
COUNT-C _{DOWN}	Time varying parameter for synchronisation of ciphering	1 per logical channel	Lifetime of a logical channel	32 bits	Mandatory
BEARER	Logical channel identifier	1 per logical channel	Lifetime of a logical channel	8 bits	Mandatory
DIRECTION	An indication of the direction of transmission uplink or downlink	1 per logical channel	Lifetime of a logical channel	1 bit	Mandatory

The following cryptographic functions shall be implemented in the RNC:

- f8: access link encryption function.

Table 11: provides an overview of the cryptographic functions that shall be implemented in the RNC:

Table11: RNC – Data integrity – Cryptographic functions

Symbol	Description	Multiplicity	Lifetime	Standardised / Proprietary	Mandatory / Optional
f9	Access link data integrity function	1-16	Permanent	Standardised	One at least is mandatory

4.4.2 Data integrity (DI_{rnc})

The RNC shall support the UMTS mechanism for data integrity of signalling data described in 6.4 of 3G TS 33.102.

The RNC shall store the following data elements:

- a) UIA-RNC: the integrity capabilities of the RNC;

In addition, when in dedicated mode:

- b) UIA: the selected UMTS integrity algorithm;
- c) IK: an integrity key;
- d) COUNT-I_{UP}: a time varying parameter for synchronisation of data integrity in the uplink direction;
- e) COUNT-I_{DOWN}: a time varying parameter for synchronisation of data integrity in the downlink direction;
- f) DIRECTION: An indication of the direction of transmission uplink or downlink to ensure a different cipher is applied
- g) FRESH: an MS challenge;

Table 12 provides an overview of the data elements stored on the UE to support the mechanism for data confidentiality:

Table12: UE – Data Integrity – Data elements

Symbol	Description	Multiplicity	Lifetime	Length	Mandatory / Optional
UIA-RNC	Data integrity capabilities of the RNC	1	Permanent	16 bits	Mandatory
UIA	Selected data integrity capability	1 per user	Lifetime of a connection	4 bits	Mandatory
IK	Integrity key	1 per user	Lifetime of a connection	128 bits	Mandatory
DIRECTION	An indication of the direction of transmission uplink or downlink	1 per logical channel	Lifetime of a logical channel	1 bit	Mandatory
COUNT-I _{UP}	Synchronisation value	1	Lifetime of a connection	32 bits	Mandatory
COUNT-I _{DOWN}	Synchronisation value	1	Lifetime of a connection	32 bits	Mandatory
FRESH	MS challenge	1	Lifetime of a connection	32 bits	Mandatory
MAC-I XMAC-I	Message authentication code	1	Updated by the execution of the AKA protocol	32 bits	Mandatory

The following cryptographic functions shall be implemented on the UE:

- f9: access link integrity function.

Table 13 provides an overview of the cryptographic functions implemented in the UE:

Table 13: UE – Data Integrity – Cryptographic functions

Symbol	Description	Multiplicity	Lifetime	Standardised / Proprietary	Mandatory / Optional
f9	Access link data integrity function	1-16	Permanent	Standardised	One at least is mandatory

4.5 SN (or MSC/VLR or SGSN)

4.5.1 User identity confidentiality (UIC_{SN})

The VLR (equivalently the SGSN) shall support the UMTS conventional mechanism for user identity confidentiality described in 6.1 of 3G TS 33.102.

The VLR shall store the following data elements:

- TMUI-CS: a temporary identity allocated by the CS core network;
- LAI: a location area identifier;

Table 14: VLR – User Identity Confidentiality – Data elements

Symbol	Description	Multiplicity	Lifetime	Length	Mandatory / Optional
TMUI-CS	Temporary user identity	2 per user	Updated when TMUI allocation protocol is executed by CS core network		Mandatory
LAI	Location area identity	2 per user	Updated when TMUI allocation protocol is executed by CS core network		Mandatory

Equivalently, the SGSN shall store the following data elements:

- TMUI-PS: a temporary identity allocated by the PS core network;
- RAI: a routing area identifier
-

Table 15: SGSN – User Identity Confidentiality – Data elements

Symbol	Description	Multiplicity	Lifetime	Length	Mandatory / Optional
TMUI-PS	Temporary user identity	1 per user	Updated when TMUI allocation protocol is executed by PS core network		Mandatory
RAI	Routing area identity	1 per user	Updated when TMUI allocation protocol is executed by PS core network		Mandatory

4.5.2 Authentication and key agreement (AKA_{SN})

The VLR (equivalently the SGSN) shall support the UMTS mechanism for authentication and key agreement described in 6.3 of 3G TS 33.102.

The following data elements need to be stored in the VLR (and SGSN):

a) AV: Authentication vectors;

Table 16 provides an overview of the composition of an authentication vector

Table 16: Composition of an authentication vector

Symbol	Description	Multiplicity	Length
RAND	Network challenge	1	128
XRES	Expected response	1	32-128
CK	Cipher key	1	128
IK	Integrity key	1	128
AUTN	Authentication token	1 that consists of:	112-144
SQN or $SQN \oplus AK$	Sequence number Or Concealed sequence number	1 per AUTN	32-64
AMF	Authentication Management Field	1 per AUTN	16
-MAC-A	Message authentication code for network authentication	1 per AUTN	64

b) KSI: Key set identifier;

c) CK: Cipher key;

d) IK: Integrity key.

e) GSM AV: Authentication vectors for GSM

Table 17 provides an overview of the data elements stored in the VLR/SGSN to support authentication and key agreement.

Table 17: VLR/SGSN – Authentication and key agreement – Data elements

Symbol	Description	Multiplicity	Lifetime	Length	Mandatory / Optional
UMTS AV	UMTS Authentication vectors	several per user, SN dependent	Depends on many things	528-656	Mandatory
KSI	Key set identifier	1 per user	Updated when AKA protocol is executed	3 bits	Mandatory
CK	Cipher key	1 per user	Updated when AKA protocol is executed	128 bits	Mandatory

IK	Integrity key	1 per user	Updated when AKA protocol is executed	128 bits	Mandatory
GSM AV	GSM Authentication vectors	As for GSM	As for GSM	As for GSM	Optional

The following cryptographic functions shall be implemented in the VLR/SGSN

- c4: Conversion function for interoperation with GSM from Kc (GSM) to CK (UMTS)
- c5: Conversion function for interoperation with GSM from Kc (GSM) to IK (UMTS)
- Table 18: provides an overview of the cryptographic functions implemented on the UE to support the mechanism for data confidentiality.

Table 18: VLR/SGSN Authentication and Key Agreement – Cryptographic functions

Symbol	Description	Multiplicity	Lifetime	Standardised / Proprietary	Mandatory / Optional
c4	<u>Conversion function for interoperation with GSM</u>	<u>1</u>	<u>Permanent</u>	<u>Standardised</u>	<u>Optional</u>
c5	<u>Conversion function for interoperation with GSM</u>	<u>1</u>	<u>Permanent</u>	<u>Standardised</u>	<u>Optional</u>

4.6 Home location register / Authentication centre

4.6.1 Enhanced User Identity Confidentiality (EUIC_{HE})

For UMTS users with EUIC, the HLR/AuC has to store additional data and have additional function implemented to decrypt the permanent user identity (IMSI). We describe the requirements as regards data storage and algorithm implementation for the example mechanism in annex B of 3G TS 33.102.

The following data elements need to be stored on the HLR/AuC:

- a) GK: the group key used to decrypt the IMSI and SQN_{UIC};
- b) GI: a group identifier that identifies the group the user refers to as well as the GK;

Table 189: HLR/AuC – Enhanced User Identity Confidentiality – Data elements

Symbol	Description	Multiplicity	Lifetime	Length	Mandatory / Optional
GK	Group key	1 per user group	Permanent	128	Optional
GI	Group Identity	1 per user	Permanent	32 bits	Optional

The following cryptographic functions need to be implemented in the HLR/AuC:

- f7: the user identity decryption function.

For a summary of the data elements and cryptographic function of the $EUIC_{HE}$ function see Table 2.

Table 1920: HLR/AuC – Enhanced User Identity Confidentiality – Cryptographic functions

Symbol	Description	Multiplicity	Lifetime	Standardised / Proprietary	Mandatory / Optional
f7	User identity decryption function	1	Permanent	Proprietary	Optional

4.6.2 Authentication and key agreement (AKA_{he})

The HLR/AuC shall support the UMTS mechanism for authentication and key agreement described in 6.3 of 3G TS 33.102.

The following data elements need to be stored in the HLR/AuC:

- K: a permanent secret key;
- SQN_{HE} : a counter used to generate SQN from;
- AV: authentication vectors computed in advance;

Table 201 provides an overview of the data elements stored on the HLR/AuC to support authentication and key agreement.

Table 201: HLR/AuC – Authentication and key agreement – Data elements

Symbol	Description	Multiplicity	Lifetime	Length	Mandatory / Optional
K	Permanent secret key	1	Permanent	128 bits	Mandatory
SQN_{HE}	Sequence number counter	1	Updated when AVs are generated	32-64 bits	Mandatory
UMTS AV	UMTS Authentication vectors	HE option	Updated when AVs are generated	544-640 bits	Optional
GSM AV	GSM Authentication vectors	HE option that consists of:	Updated when AVs are generated	As GSM	Optional
RAND	GSM Random challenge			128 bits	Optional
SRES	GSM Expected response			32 bits	Optional
Kc	GSM cipher key			64 bits	Optional

Table 22 shows how the construction of authentication token for synchronisation failure messages used to support authentication and key agreement

Table 22: Composition of an authentication token for synchronisation failure messages

Symbol	Description	Multiplicity	Length
AUTS	Synchronisation Failure authentication token	that consists of:	96 –128
SQN	Sequence number	1 per AUTS	32-64
MAC-S	Message authentication code for Synchronisation Failure messages	1 per AUTS	64

Figure 4: Generation of an authentication vector provides an overview of how authentication vectors are generated in the HLR/AuC.

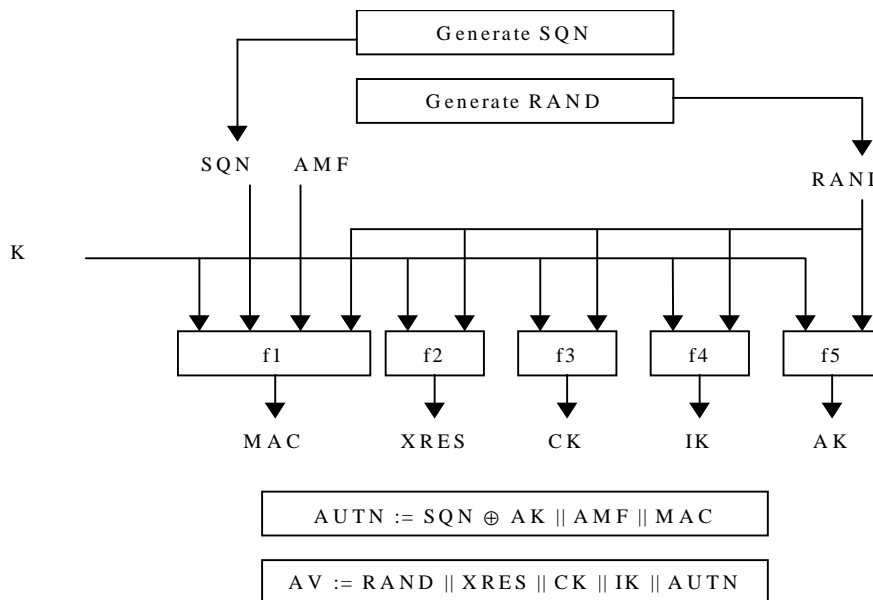

Figure 4: Generation of an authentication vector

The following cryptographic functions need to be implemented in the HLR/AuC:

- f1: a message authentication function for network authentication;
 - f1*: a message authentication function for support to re-synchronisation;
 - f2: a message authentication function for user authentication;
 - f3: a key generating function to derive the cipher key;
 - f4: a key generating function to derive the integrity key;
 - f5: a key generating function to derive the anonymity key.
- c1: Conversion function for interoperation with GSM from RAND (UMTS) > RAND (GSM)
 - c2: Conversion function for interoperation with GSM from XRES (UMTS) to SRES (GSM)
 - c3: Conversion function for interoperation with GSM from CK and IK (UMTS) to Kc (GSM)

Table 243 provides a summary of the cryptographic functions implemented on the USIM to support authentication and key agreement.

Table 243: HLR/AuC – Authentication and key agreement – Cryptographic functions

Symbol	Description	Multiplicity	Lifetime	Standardised / Proprietary	Mandatory / Optional
f1	Network authentication function	1	Permanent	Proprietary	Mandatory
f1*	Message authentication function for synchronisation	1	Permanent	Proprietary	Mandatory
f2	User authentication function	1	Permanent	Proprietary	Mandatory
f3	Cipher key generating function	1	Permanent	Proprietary	Mandatory
f4	Integrity key generating function	1	Permanent	Proprietary	Mandatory
f5	Anonymity key generating function	1	Permanent	Proprietary	Optional
A3/A8	GSM user authentication functions	1	Permanent	Proprietary	Optional
<u>c1</u> , <u>c2</u> and <u>c3</u>	Functions for converting UMTS AV's to GSM AV's	1 for each	Permanent	Standard	Optional

5 Provider domain security

5.1 Functional security architecture

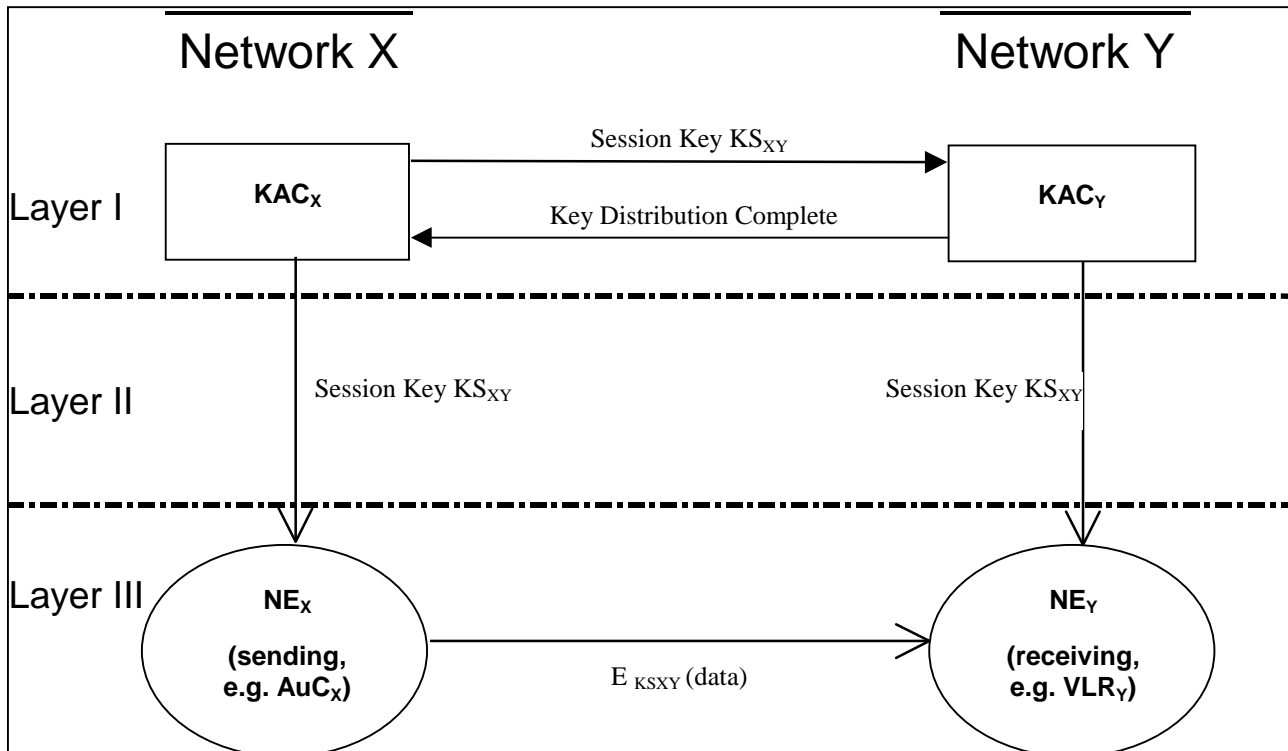

Overview of Proposed Mechanism

This mechanism establishes a secure signalling links between network nodes, in particular between ~~SN/VLR/VLR/SGSNs~~ and HE/AuCs. Such procedures may be incorporated into the roaming agreement establishment process.

A secret key transport mechanism based on an asymmetric crypto-system is used to agree on a symmetric session key for each direction of communication between two networks X and Y.

The party wishing to send sensitive data initiates the mechanism and chooses the symmetric session key it wishes to use for sending the data to the other party. The other party shall choose a symmetric session key of its own, used for sending data in the other direction. This second key shall be transported immediately after the first key has been successfully transported. The session symmetric keys are protected by asymmetric techniques. They are exchanged between certain elements called the *Key Administration Centres* (KACs) of the network operators X and Y.

Transport of Session Keys

In order to establish a symmetric session key with version no. i to be used for sending data from X to Y, the KAC_X sends a message containing the following data to the KAC_Y:

$$E_{PK(Y)} \{ X || Y || i || KS_{XY}(i) || RND_X || Text1 || D_{SK(X)}(Hash(X || Y || i || KS_{XY}(i) || RND_X || Text1)) || Text2 \} || Text3$$

After having successfully distributed the symmetric session key received by network X to its own network entities, network Y sends to X a Key Distribution Complete Message. This is an indication to KAC_X to start with the distribution of the key to its own entities, which can then start to use the key immediately.

The message takes the form

$\text{KEY_DIST_COMPLETE} \parallel Y \parallel X \parallel i \parallel \text{RND}_Y \parallel D_{SK(Y)}(\text{Hash}(\text{KEY_DIST_COMPLETE} \parallel Y \parallel X \parallel i \parallel \text{RND}_Y))$

where i indicates the distributed key and RND_Y is a random number generated by Y . The digital signature is appended for integrity and authenticity purposes. Y includes RND_Y to make sure that the message contents determined by X will be modified before signing.

Since most of the signalling messages to be secured are bidirectional in character, immediately after successful completion the procedure described here shall be repeated, now with Y choosing a key $\text{KS}_{YX}(i)$ to be used in the reverse direction, and X being the receiving party. Thereby keys for both directions are established.

5.2 Key Authentication Centre

Details in security architecture to be finalised

5.3 Core network entities

Table 224 Signalling Protection- Data Elements

Symbol	Description	Multiplicity	Lifetime	Length	Mandatory / Optional
PVTK _s	Network's own Private Key (signing)	1	According to roaming agreement	< or = 2048 bits	Mandatory
PVTK _d	Network's own Private Key (decryption)	1	According to roaming agreement	< or = 2048 bits	Mandatory
PUBK _{v1}	PKR ₁ Public Key for network #1 (verify)	1 per roaming agreement	According to roaming agreement	< or = 2048 bits	Mandatory
PUBK _{e1}	PKR ₁ Public Key for network #1 (encryption)	1 per roaming agreement	According to roaming agreement	< or = 2048 bits	Mandatory
KS _{XY(i)}	Symmetric Send Key #i for sending data from X to Y	1 per session	According to roaming agreement	128 bits	Mandatory
KS _{YX(j)}	Symmetric Send Key #j for sending data from Y to X	1 per session	According to roaming agreement	128 bits	Mandatory
I	Session key Sequence Number (for sending data from X to Y)	1 per session	According to roaming agreement	32 – 64 bits	Mandatory
J	Session key Sequence Number (for sending data from Y to X)	1 per session	According to roaming agreement	32 – 64 bits	Mandatory
RND _X	Unpredictable Random Value generated by X	1 per session	Session	128 bits	Mandatory
RND _Y	Unpredictable Random Value generated by Y	1 per session	Session	128 bits	Mandatory

Table 235 Signalling Protection –Cryptographic Functions

Symbol	Description	Multiplicity	Lifetime	Standardised / Proprietary	Mandatory / Optional
BEANO	Block Encryption Algorithm for Network Operators	1	Permanent	Standardised	Mandatory

6 Network Wide Confidentiality

Network-wide confidentiality is an option, which provides a protected mode of transmission on user traffic channels across the entire network. This gives users assurance that their traffic is protected against eavesdropping on every link within the network, i.e. not just the particularly vulnerable radio links in the access network, but also on the fixed links within the core network.

Network-wide confidentiality is provided by protecting transmissions on user traffic channels, using a synchronous stream cipher. This uses the same algorithm as for access link encryption.

The key management scheme for network-wide encryption involves establishing a network-wide cipher key between the end points of the traffic channel. In addition to the access link cipher and integrity keys, the USIM and the MSC/VLR or equivalent SGSN also establish a network-wide cipher key component ECKC as part of the authentication and key agreement procedure. This key component will be used to generate the network-wide cipher key ECK.

Since this ECK can also be generated by MSC/VLRa or MSC/VLRb and then used by decryption facilities in the core network, the requirement for lawful interception is satisfied.

1. MSC/VLRa and MSC/VLRb shall exchange network-wide cipher keys components for UEa and UEb. - MSC/VLRa passes ECKCb to UEa, while MSC/VLRb passes ECKCa to UEb.
2. At each end the access link key is transmitted to the UE over signalling channels which are protected using the access link cipher keys CK.
3. When each UE has received the other party's network-wide cipher key component, the network-wide cipher key ECK shall be calculated as a function of ECKCa and ECKCb.

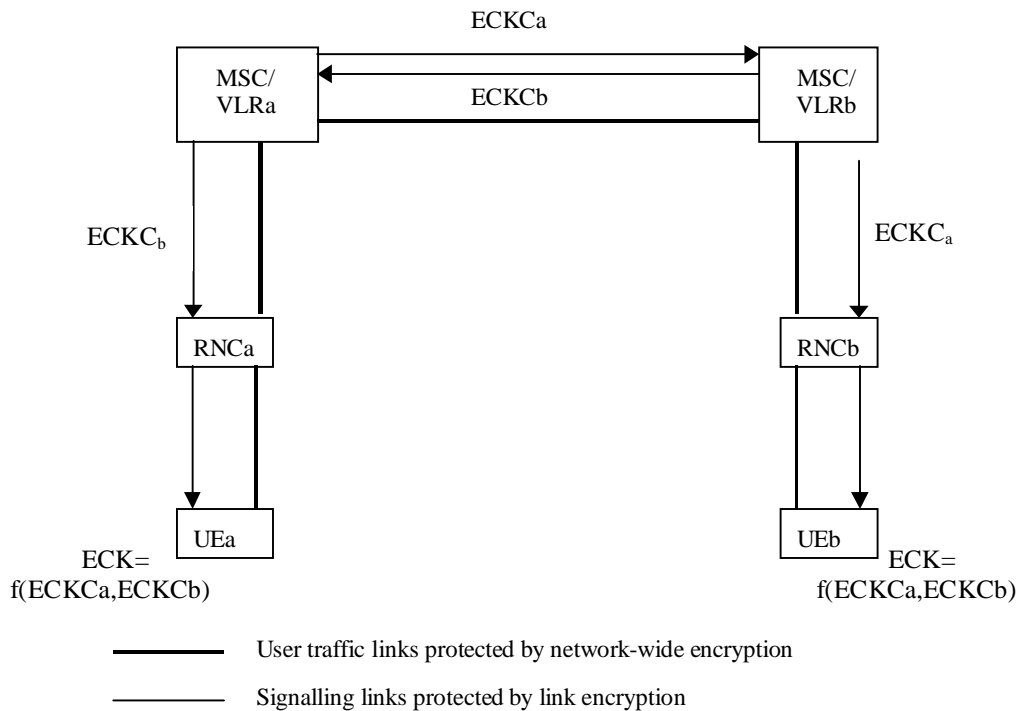

Table 246 MSC/VLR Network Wide Confidentiality – Data Elements

Symbol	Description	Multiplicity	Lifetime	Length	Mandatory / Optional
ECKC	Network-wide cipher key component for UE	1 per user	Updated when AKA protocol is executed	128 bits	Optional
ECKCpeer	Network-wide cipher key component for peer UE	1 per user	Updated when AKA protocol is executed	128 bits	Optional
ECK	the network-wide cipher key	1 per user	When required for Lawful Interception purposes	128 bits	Optional

Table 257 UE Network Wide Confidentiality – Data Elements

Symbol	Description	Multiplicity	Lifetime	Length	Mandatory / Optional
ECKC	Network-wide cipher key component for UE	1 per user	Updated when network wide traffic channel is established	128 bits	Optional
ECKCpeer	network-wide cipher key component for peer UE	1 per user	Updated when network wide traffic channel is established	128 bits	Optional
ECK	the network-wide cipher key	1 per user	Updated when network wide traffic channel is established	128 bits	Optional

Table 268 UE Network Wide Confidentiality - Cryptographic functions

Symbol	Description	Multiplicity	Lifetime	Standardised / Proprietary	Mandatory / Optional
f9	Network-wide user traffic confidentiality Algorithm	1	Permanent	Standardised	Mandatory

Annex A: Authentication mechanism based on a temporary key

When the mobile first requests service from the SN/VLR, a random seed RS_u created by the user (USIM or terminal) is included in the request message. The message including RS_u is forwarded to the HE/AuC, which generates its own random challenge RS_n . An authentication vector is returned to the SN/VLR. The vector contains $\{RS_n, RES1, XRES2, KT\}$, where $RES1$ is the response to the user's challenge, $XRES2$ is the response to the network's challenge which is expected from the user, and KT is the temporary authentication key shared with the SN/VLR. The network's challenge RS_n and the network authentication response $RES1$ are sent to the MS. If the MS verifies $RES1$, thereby authenticating the identity of the network, it responds with $RES2$ and generates the new temporary key KT . The SN/VLR then verifies that $RES2$ equals $XRES2$, thereby authenticating the identity of the USIM, and stores the new temporary key KT . Furthermore, both the USIM and the SN/VLR immediately use KT with the random seeds RS_u and RS_n to generate the first session keys CK and IK . This process is shown in Figure 4 below.

Figure 5 shows how the SN/VLR can offer secure service to the USIM without reference to the home system HE/AuC by using the temporary key KT .



Figure 4: Temporary Key Generation Protocol

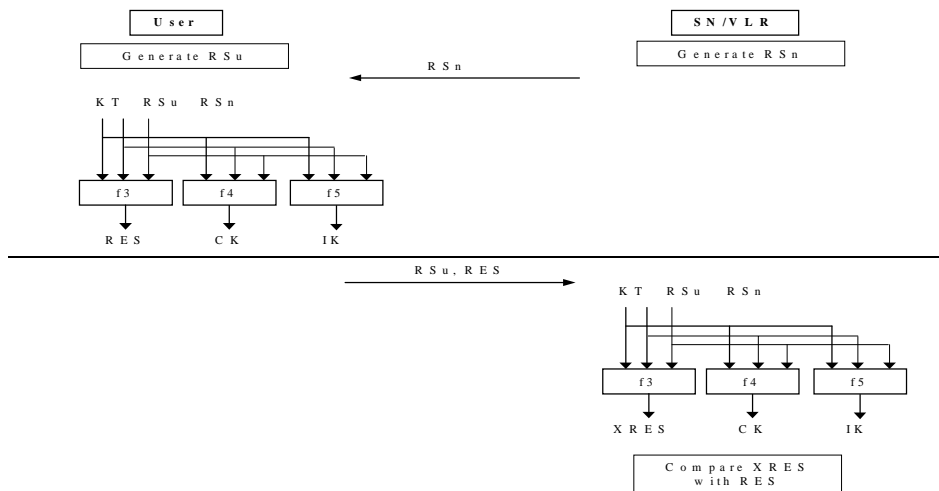

Figure 5. Locally authenticated session key agreement

A1 Security Information stored

A1.1 Home Environment Authentication Centre HE/AuC

Name	Symbol	Parameter Length (actual or min-max)	Lifetime
Dynamic Information			
Random Seed User	RS_u	128 bits	e

AV₁ Random Seed Network	RS_N	128 bits	e
—— Response to User Challenge RS_U	RES1	32-128 bits	e
—— Response to User Challenge RS_N	XRES2	32-128 bits	e
—— Temporary Key	KT	128 bits	b
AV_n Random Seed Network	RS_N	128 bits	e
—— Response to User Challenge RS_U	RES1	32-128 bits	e
— Expected Response to Nwk Challenge RS_N	XRES2	32-128 bits	e
—— Temporary Key	KT	128 bits	b
Fixed Initial Value	PAR1	TBD	a
Fixed Initial Value	PAR2	TBD	a
Fixed Initial Value	PAR3	TBD	a
Fixed Initial Value	PAR4	TBD	a
Fixed Initial Value	PAR5	TBD	a
— and common items — section 5.1			

A1.2 ~~Serving Node Visited Location Register SN/VLR~~

Name	Symbol	Parameter Length (actual or min-max)	Lifetime
Dynamic Information			
Temporary Key	KT	128 bits	b
Random Seed User	RS _U	128 bits	e
Random Seed Network	RS _N	128 bits	e
Response to Users Challenge	RES1	32-128 bits	e
Response to Network Challenge	RES2	32-128 bits	b
Response to Network Challenge	XRES2	32-128 bits	b
Cipher Key	CK*	128 bits	b
Integrity Key	IK*	128 bits	b
Response to SN/VLR challenge (local)	RES	32-128 bits	e
Expected response to challenge	XRES	32-128 bits	C

* May be computed at HE/AuC

A1.3 Radio Network Controller RNG

Name	Symbol	Parameter Length (actual or min-max)	Lifetime
See common items section 5.1			

A1.4 — USIM

Name	Symbol	Parameter Length (actual or min-max)	Lifetime
Dynamic Information			
Temporary Key	KT	128 bits	B
Random Seed User	RS _U	128 bits	e
Random Seed Network	RS _N	128 bits	e
Computed Response (local authent.)	RES	32-128 bits	B
Response to Users Challenge	RES1	32-128 bits	B
Response to Network Challenge	RES2	32-128 bits	e
Expected response to network challenge	XRES1	32-128 bits	e
— and common items — section 5.1			

A1.5 — Mobile Equipment

Name	Symbol	Parameter Length (actual or min-max)	Lifetime
See common items — section 5.1			

A2 — Location of Security Functions

A2.1 — Home Environment Authentication Centre HE/AuC

Name	Symbol	Input Parameters
Algorithms		
Key Generating Function	F1	Input: K, RS _U , RS _N Output: KT
Message Authentication Function	F2	Input: K, RS _U , RS _N Output: RES1
Message Authentication Function	F3	Input: K, RS _U , RS _N Output: XRES1
— and common items		

A2.2 ~~Serving Node Visited Location Register SN/VLR~~

Name	Symbol	Input Parameters
Algorithms		* May be computed at HE/AuC
Message Authentication Function (local authentication only)	F3	Input: KT, RS_U, RS_N Output: XRES
Cipher Key Generating Function	F4	Input: KT, RS_U, RS_N Output: CK*
Integrity Key Generating Function	F5	Input: KT, RS_U, RS_N Output: IK*
and common items		

A2.3 ~~Radio Network Controller RNG~~

Name	Symbol	Input Parameters
Algorithms		
<i>See common items</i>		

A2.4 ~~Mobile Equipment user identity Module USIM~~

Name	Symbol	Input Parameters
Algorithms		
Key generating function	F1	Input: K, RS_U, RS_N Output: KT
Message Authentication Function	F2	Input: K, RS_U, RS_N Output: XRES1
Message Authentication Function	F3	Input: K, RS_U, RS_N Output: RES2
Message Authentication Function (for local authentication)	F3	Input: KT, RS_U, RS_N Output: RES
Cipher Key Generating Function	F4	Input: KT, RS_U, RS_N Output: CK
Integrity Key Generating Function	F5	Input: KT, RS_U, RS_N Output: IK

A2.5 ~~Mobile Equipment ME~~

Name	Symbol	Input Parameters
Algorithms		
<i>see common items</i>		

7 Annex B (informative): Change history

Document history		
3.0.0	October 1999	Approved by TSG SA #5
3.1.0	December 1999	Inclusion of CR001r1, CR 002r1 and CR 004 approved by TSG-SA#6
<u>3.2.0</u>	<u>February 2000</u>	DRAFT to line up with 33.102 at SA3#10 Removal of window and list options Removed annex A Add conversion functions c1 to c5 Add details of AUTS and MACS replaced with MAC-S Add footnote to clarify the relationship of f8 to UEA etc
Rapporteur: Colin Blanchard		

History

Document history		
V3.0.0	October 1999	
V3.1.0	December 1999	
<u>V3.2.0</u>	<u>February 2000</u>	