

**TSG-RAN Working Group 3 meeting #1**  
**Bonn, Germany**  
**February 2-5, 1999**

**TSGW3#1(99)094**

**Source: Editor**

**Title: Merged Description of Iub Interface**

**Date: February 4, 1999**

---

## **Description of I<sub>ub</sub> Interface**

---

---

# Contents

<b>1. INTELLECTUAL PROPERTY RIGHTS</b> .....	<b>34</b>
<b>2. FOREWORD</b> .....	<b>34</b>
<b>3. SCOPE</b> .....	<b>34</b>
<b>4. REFERENCES</b> .....	<b>34</b>
<b>5. DEFINITIONS, ABBREVIATIONS AND NOTATION</b> .....	<b>45</b>
5.1 DEFINITIONS .....	45
5.2 ABBREVIATIONS .....	45
5.3 NOTATION.....	45
<b>6. GENERAL ASPECTS</b> .....	<b>45</b>
6.1 UTRAN ARCHITECTURE .....	45
6.2 I <sub>UB</sub> -INTERFACE GENERAL PRINCIPLES AND SPECIFICATION OBJECTIVES.....	45
6.3 I <sub>UB</sub> -INTERFACE CAPABILITIES .....	56
6.4 I <sub>UB</sub> -INTERFACE CHARACTERISTICS.....	56
<b>7. I<sub>UB</sub>-INTERFACE PROTOCOL FUNCTIONS</b> .....	<b>67</b>
7.1 INTERFACE FUNCTIONS.....	67
<b>8. I<sub>UB</sub>-INTERFACE PROTOCOL STRUCTURE</b> .....	<b>67</b>
<b>9. I<sub>UB</sub>-INTERFACE PROTOCOL LAYER SPECIFICATION FOR RADIO NETWORK CONTROL PLANE</b> .....	<b>89</b>
9.1 INTRODUCTION .....	89
9.2 RADIO NETWORK LAYER .....	89
9.2.1 <i>General</i> .....	89
9.2.2 <i>NBAP Procedures</i> .....	89
9.2.2.1 NBAP Common Procedures.....	89
9.2.2.2 NBAP Dedicated Procedures.....	1044
9.2.3 <i>NBAP Messages</i> .....	1314
9.2.3.1 Message Contents.....	1445
9.2.4 <i>Signalling Element Coding</i> .....	1920
9.3 TRANSPORT LAYER .....	2525
9.3.1 <i>General</i> .....	2525
9.3.2 <i>Signalling Bearer</i> .....	2525
<b>10. I<sub>UB</sub>-INTERFACE PROTOCOL LAYER SPECIFICATION FOR TRANSPORT NETWORK CONTROL PLANE</b> .....	<b>2526</b>
10.1 INTRODUCTION .....	2526
10.2 TRANSPORT LAYER .....	2526
10.2.1 <i>General</i> .....	2526
10.2.2 <i>ALCAP</i> .....	2526
10.2.3 <i>Signalling Bearer</i> .....	2626
<b>11. I<sub>UB</sub>-INTERFACE PROTOCOL LAYER SPECIFICATION FOR USER PLANE</b> .....	<b>2626</b>
11.1 INTRODUCTION .....	2626
11.2 RADIO NETWORK LAYER.....	2627
11.2.1 <i>General</i> .....	2627
11.2.2 <i>Dedicated Channel Frame Protocol</i> .....	2627
11.2.2.1 Dedicated Channel Procedures.....	2728
11.2.2.2 Iur / Iub DCH Data Stream Synchronisation.....	2829

11.2.3	FACH Frame Protocol.....	2829
11.2.4	RACH Frame Protocol.....	2829
11.2.5	DSCH Frame Protocol.....	2829
11.3	TRANSPORT LAYER .....	2829
<b>12.</b>	<b>PHYSICAL LAYER.....</b>	<b>2930</b>
<b>13.</b>	<b>EXAMPLE SEQUENCES.....</b>	<b>2930</b>
<b>14.</b>	<b>HISTORY .....</b>	<b>2930</b>
<b>ANNEX IUB PARAMETERS LIST .....</b>		<b>3031</b>

## 1. Intellectual Property Rights

## 2. Foreword

## 3. Scope

This document shall provide a description of the UTRAN RNC-NodeB (Iub) interface as agreed within 3GPP RAN working group #3.

## 4. References

References may be made to:

- a) specific versions of publications (identified by date of publication, edition number, version number, etc.), in which case, subsequent revisions to the referenced document do not apply;
- b) all versions up to and including the identified version (identified by “up to and including” before the version identity);
- c) all versions subsequent to and including the identified version (identified by “onwards” following the version identity); or
- d) publications without mention of a specific version, in which case the latest version applies.

A non-specific reference to an ETS shall also be taken to refer to later versions published as an EN with the same number.

- |         |   |
|---------|---|
| [1] [1] | ZZ.01, UTRAN Architecture Description, Editor (Nortel)  |
| [2] [2] | UMTS 23.10 UMTS Access Stratum Services and Function  |
| [3] [3] | Tdoc SMG2 UMTS-L23 110/98, Vocabulary used in the UMTS L2&L3 Expert Group                     |
| [4] [4] | ZZ.12, Description of I <sub>ur</sub> Interface, Editor (Ericsson)                            |
| [5] [5] | ZZ.11, Description of I <sub>u</sub> Interface, Editor (Nokia)                                |
| [6] [6] | YY.01, MS-UTRAN Radio Interface Protocol Architecture, Editor (Ericsson)                      |
| [7] [7] | ITU-T I.363.2 B-ISDN ATM Adaptation Layer Specification: Type 2 AAL                           |
| [8] [8] | ITU-T I.366.1 Segmentation and Reassembly Service Specific Convergence Sublayer for AAL Type2 |
| [9] [9] | ITU-T Draft new ITU-T Recommendation Q.aal2 AAL Type2 Signalling Protocol, November 1998      |

---

## 5. Definitions, Abbreviations and Notation

### 5.1 Definitions

*[Editor's note: For list of definitions, see [1].]*

### 5.2 Abbreviations

*[Editor's note: For list of abbreviations, see [1].]*

### 5.3 Notation

*[Editor's note: This text has been copied from [1].]*

Parts of the document apply only to one mode, FDD or TDD. Any such area will be tagged by [FDD — xxxxxxxxx] and [TDD — yyyyyyyyyyy] respectively. The tag applies to the text until the closing bracket.

---

## 6. General Aspects

### 6.1 UTRAN Architecture

*[Editor's note: This chapter should describe the UTRAN architecture from I<sub>ub</sub> point of view. The RNS architecture with its elements RNC and NodeB is described to facilitate the description of functional split in chapter 7. In order to avoid inconsistency between documents, reference to [1], chapter 8, has been made.]*

For the description of the UTRAN architecture see [1], chapter 8.

### 6.2 I<sub>ub</sub> -Interface General Principles and Specification Objectives

The I<sub>ub</sub> interface specifications shall facilitate the following:

- Inter-connection of RNCs and NodeBs from different manufacturers;
- Separation of I<sub>ub</sub> interface Radio Network functionality and Transport Network functionality to facilitate introduction of future technology.

The general principles for the specification of the Iub interface are as follows:

- Transmission sharing between the GSM/GPRS Abis interface and the Iub interface shall not be precluded.
- The functional division between RNC and NodeB shall have as few options as possible;
- Iub should be based on a logical model of NodeB;
- NodeB controls a number of cells and can be ordered to add/remove radio links in those cells;
- Neither the physical structure nor any internal protocols of the NodeB shall be visible over Iub and are thus not limiting factors, e.g., when introducing future technology.
- Operation and Maintenance of NodeB hardware and software resources is not a part of the Iub standardisation.  
Note: It is FFS which functions belong to this group.
- Complex functionality shall as far as possible be avoided over Iub. This is important so that the Iub specification is ready on time. Advanced optimisation solutions may be added in later versions of the standard.
- The Iub functional split shall take into account the probability of frequent switching between different channel types.

The Iub parts to be standardised by ~~TSG-RAN~~TSG-RAN are:

1. User data
2. Signalling for handling the user data

### 3. Management of logical resources of Node B

Note: The definition of logical resources is FFS.

It should be possible to transport the O&M information via the Iub interface and, hence, the lower layer transport mechanisms should be standardised to this effect. The content of the O&M information is not specified in this document but will be described in an external document which is tbd. standardised by SMG2 and it is up to SMG6 to decide how to handle it.

## 6.3 I<sub>ub</sub> -Interface Capabilities

The Iub interface connects a RNC and a Node B.

The information transferred over the Iub reference point can be categorised as follows:

### 1. Radio application related signalling

The Iub interface allows the RNC and the Node B to negotiate about radio resources, for example to add and delete cells controlled by the Node B to support communication of the dedicated connection between UE and SRNC. Information used to control the broadcast and paging channels, and information to be transported on the broadcast and paging channels, belong to this category also.

### 2. Iub/Iur DCH data stream

The Iub interface provides means for transport of uplink and downlink DCH Iub frames between RNC and Node B. The DCH Iub frame header includes uplink quality estimates and synchronisation information. The DCH Iub frame body comprises of data to be transferred over the radio interface. The DCH Iub frames can be carried on pre-defined transmission links or switched connections.

One Iub/Iur DCH data stream is carried on one transport bearer.

### 3. Iub RACH data stream

The Iub interface provides means for transport of uplink RACH transport frames between RNC and Node B. The RACH transport frame header includes synchronisation information. The RACH transport frame body includes the data received over radio interface. The transport frames can be carried on pre-defined transmission links or switched connections. One Iub RACH data stream is carried on one transport bearer.

For each RACH in a cell, a Iub RACH data stream must be established over the Iub interface.

### 4. Iub FACH data stream

The Iub interface provides means for transport of downlink FACH transport frames between RNC and Node B. The FACH transport frame header includes synchronisation information. The FACH transport frame body includes the data to be sent over radio interface. The transport frames can be carried on pre-defined transmission links or switched connections. One Iub FACH data stream is carried on one transport bearer.

For each FACH in a cell, a Iub FACH data stream must be established over the Iub Interface.

### 5. Iub DSCH data stream

The Iub interface provides the means for transport of downlink shared channel, DSCH, data frames between RNC and Node B. The DSCH Iub frame body comprises of data to be transferred over the radio interface. The DSCH Iub frames can be carried on pre-defined transmission links or switched connections.

One Iub DSCH data stream is carried on one transport bearer.

## 6.4 I<sub>ub</sub> -Interface Characteristics

*[Editor's note: This chapter should shortly describe the I<sub>ub</sub> -Interface Characteristics.]*

---

## 7. I<sub>ub</sub> -Interface Protocol Functions

*[Editor's note: This chapter should describe the functions of the Iub interface. For information about the Iub interface functional division, see [1].]*

### 7.1 Interface Functions

The list of functions on the Iub interface is the following:

1. Management of Iub Transport Resources
2. Logical OA&M of Node B
  - Iub Signalling Bearer Management
  - Cell Configuration Management
  - Interference Measurements
  - Notification of Available Logical Resources
  - Common Channels Management
  - Radio Resource Management
3. Physical OA&M Transport
4. Traffic Management of Common Channels
  - Admission Control
  - Power Management
  - Data Transfer
5. Traffic Management of Dedicated Channels
  - Channel Allocation / De-allocation
  - Power Management
  - Measurement Reporting
  - Dedicated Transport Channel Management
  - Data Transfer
6. Traffic Management of Downlink Shared Channels (FFS)
  - Channel Allocation / Deallocation
  - Power Management
  - Transport Channel Management
  - Data Transfer
7. Timing and Synchronisation Management

---

## 8. I<sub>ub</sub> -Interface Protocol Structure

*[Editor's note: This chapter should provide an introduction to the structure of the Iub interface protocols.]*

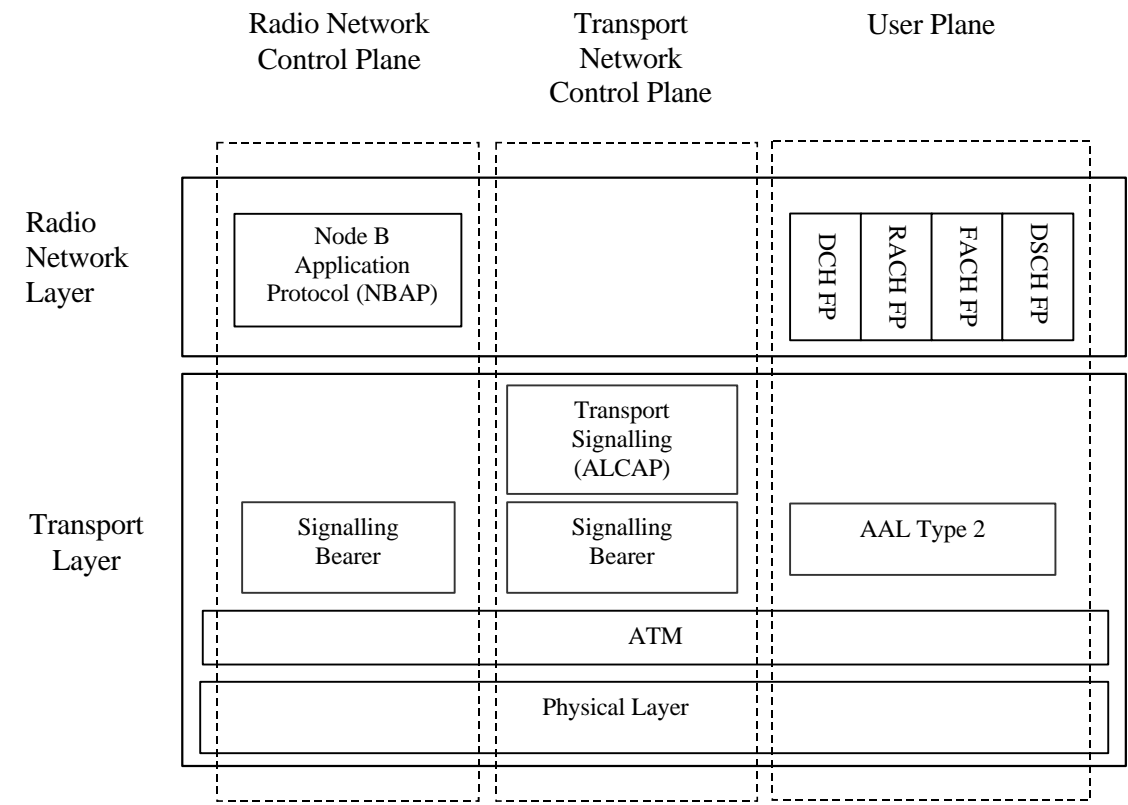

**Figure 1: Iub Interface Protocol Structure.**

**Note: The possibility to share AAL2 needs further clarification; the FAUSCH FP is FFS.**

The Iub interface protocol architecture consists of two functional layers:

1. Radio Network Layer, defines procedures related to the operation of Node B. The radio network layer consists of a radio network control plane and a radio network user plane.
2. Transport Layer, defines procedures for establishing physical connections between Node B and the RNC.

Figure 2 shows the TTC/ARIB proposal for the Iub interface protocol structure. This proposal is FFS.

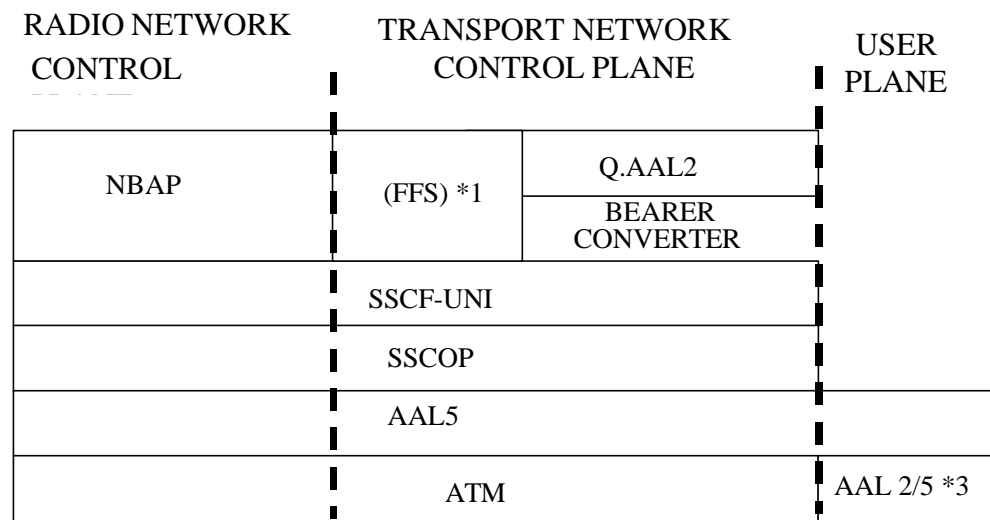

**Figure 2: TTC/ARIB Iub Interface Protocol Structure.**

Note \*1: It is FFS which signalling protocol sets up AAL5 connections. Note \*3: It is FFS whether AAL5 is applied to User plane. Note: It is FFS how to distinguish NBAP from signalling protocol.

## 9. I<sub>ub</sub> -Interface Protocol Layer Specification for Radio Network Control Plane

### 9.1 Introduction

*[Editor's note: This chapter should give an introduction to the protocol layer specification for Radio Network Control Plane.]*

### 9.2 Radio Network Layer

#### 9.2.1 General

*[Editor's note: This chapter should describe requirements on protocol capabilities, principles, etc. .]*

Node B Application protocol, NBAP, includes common procedures and traffic handling procedures. It covers procedures for paging distribution, broadcast system information, request / complete / release of dedicated resources and management of logical resources.

Note that the issue of transport layer addressing is FFS.

#### 9.2.2 NBAP Procedures

NBAP procedures are divided into common procedures and dedicated procedures.

- NBAP common procedures are procedures that request initiation of a UE context for a specific UE in Node B or are not related to a specific UE.
- NBAP dedicated procedures are procedures that are related to a specific UE context in Node B. This UE context is identified by a UE context identity.

The two types of procedures may be carried on separate signalling links.

##### 9.2.2.1 NBAP Common Procedures

###### 9.2.2.1.1 Common Channels Management

This procedure provides the capability to activate common channel resources such as [cell broadcast channels and] random access channels. The ability to control, for example, paging retransmission should also be provided. Information on common channel performance (eg overload) should be provided by node B to the RNC.

###### 9.2.2.1.2 Radio Resource Management

This procedure controls the physical radio system, eg transmitter tuning and output power control functions. Procedures [will], for example, also provide for the RNC to be informed of the automatic reconfiguration of node B in the case of partial failures and the availability of redundant radio equipment.

###### 9.2.2.1.3 Iub Signalling Bearer Management

This procedure shall deal with the management of the Iub link. This will address not only initial link establishment, but also the ongoing monitoring of link health, link recovery, load sharing and distribution.



#### 9.2.2.1.4 Interference Measurements

#### 9.2.2.1.5 Cell Configuration Management

This procedure provides the means for the RNC to configure some of the parameters of the node B and also the means for the node B to transfer the values of these and other parameters to the RNC. Examples are: RF parameters, system information parameters and, channel configuration data.

#### 9.2.2.1.6 Notification of Available Logical Resources

When the resources of node B which are available to the RNC change (eg due to failures within Node B or due to interactions with OMC-B), this procedure provides the means to inform the RNC of this change and/or to warn the RNC of the impending change.

#### 9.2.2.1.7 Radio Link Setup Request

This NBAP common procedure is used when there is no Radio Link for this UE in the Node B.

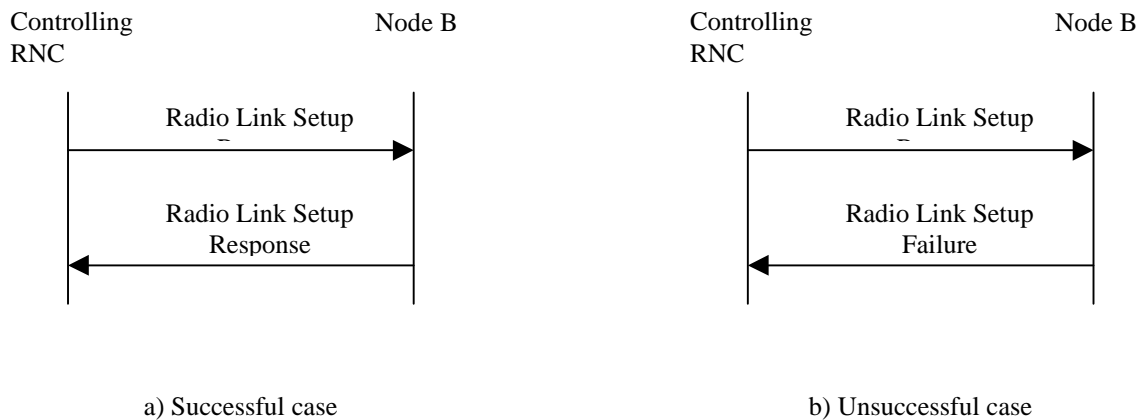

The RADIO LINK SETUP REQUEST message contains the following information (the identification of the UE is FFS):

- UL Radio Resource (UL Scrambling Code, UL Channelisation Code)
- DL Radio Resource (DL Channelisation Codes per Radio Link, DL Scrambling Code is FFS)
- DCH Information (DCH Identifier, Transmission Rate, Transport Format Set) (for each DCH in the UE)
- Transport Format Combination Set
- Power control information
- Frequency
- RL identifier #1
- Target cell identifier #
- RL identifier #2
- Target cell identifier #
- Soft combining indication (may, must, or must not be combined with already existing radio links)
- .....
- RL identifier #n
- Target cell identifier #
- Soft combining indication (may, must, or must not be combined with already existing radio links)

The RADIO LINK SETUP RESPONSE COMPLETE message contains

- Transport layer addressing information (AAL2 address) per RL

#### 9.2.2.1.8 Paging

Note that this procedure is FFS.

This NBAP common procedure is used by the RNC to page UE which is in RRC idle state with UE identity; it is also used to page UE which is in URA connected state with RNTI. This message also includes Location Identity or URA id or a list of cells (which method is being selected is FFS) for Node B to know which cell to page and an information for calculating the paging group.

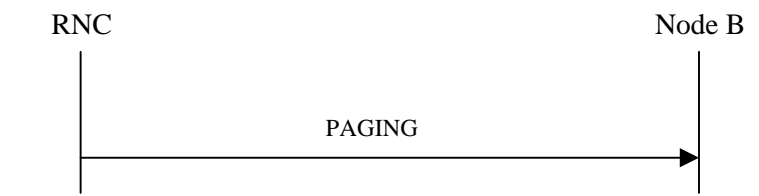

## 9.2.2.2 NBAP Dedicated Procedures

### 9.2.2.2.1 Radio Link Addition

This procedure- is used when there is already one or more existing Radio Link(s) for this UE in the Node B.

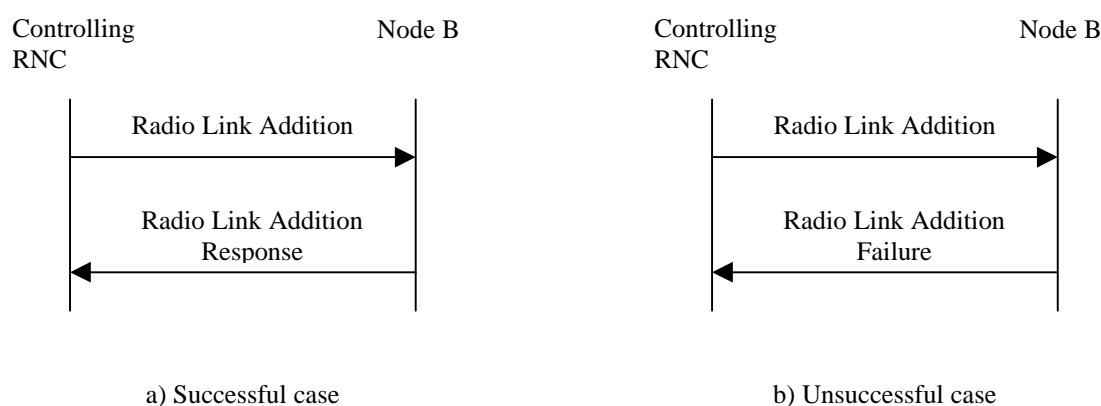

The RADIO LINK ADDITION message contains the following information (the identification of the UE is FFS):

- DL Radio Resource (DL channelisation codes) per RL
- Power control information
- the parameter “OFF” (frame offset information)
- Frequency
- RL identifier #n+1
- Target cell identifier #
- Soft combining indication (may, must, or must not be combined with already existing radio links)
- RL identifier #n+2
- Target cell identifier #
- Soft combining indication (may, must, or must not be combined with already existing radio links)
- ....

Other parameters are already known in the Node B, therefore there is no need to send them. ~~In case of inter-frequency hard handover, the “soft combining indicator” of the RL identifier #n+1 should be “must not be combined”.~~

The RADIO LINK ADDITION RESPONSE COMPLETE message contains

- Transport layer addressing information (AAL2 address, AAL2 binding ID) per RL

If the transport layer addressing information is not needed in case Node B decides to use an existing AAL2 connection, then the AAL2 address is not needed and the AAL2 binding ID of the already existing AAL2 connection is sent. If the Controlling RNC receives the AAL2 binding ID of an already existing AAL2 connection, the Controlling RNC does not execute the setting of the AAL2 connection.

### 9.2.2.2.2 Radio Link Reconfiguration

The Radio Link Reconfiguration procedure is used to reconfigure radio links related to one UE-UTRAN connection within Node B. The procedure can be used to add, delete or reconfigure a DCH. The Radio Link Reconfiguration procedure is initiated by the Controlling RNC by sending the message RADIO LINK RECONFIGURATION PREPARE REQUEST to the Node B. The message is sent using the relevant signalling connection. It includes the desired radio link parameters for the radio links to be used continuously after completion of this procedure (no change in active set). If the proposed modifications are approved by the Node B resource management algorithms, and when the Node B has successfully reserved the required resources, it responds to the Controlling RNC with the RADIO LINK RECONFIGURATION READY PROCEEDING message. In the unsuccessful case a NBAP message RADIO LINK RECONFIGURATION FAILURE is returned, indicating among other things the reason for failure. The Controlling RNC informs the UE about the changes in the RL with the relevant RRC message(s) after sending the RADIO LINK RECONFIGURATION COMMIT COMMAND message to the Node Bs. If necessary (for example when the new L1/L2 configuration cannot coexist with the old one), the SRNC selects the most suitable CFN for the switching between the old and new configuration and includes it in the RRC message and in the RADIO LINK RECONFIGURATION COMMIT COMMAND message. The Controlling RNC is responsible for releasing unnecessary Iub transport bearers (in case of DCH deletion).

This procedure is not used for adding or deleting radio links.

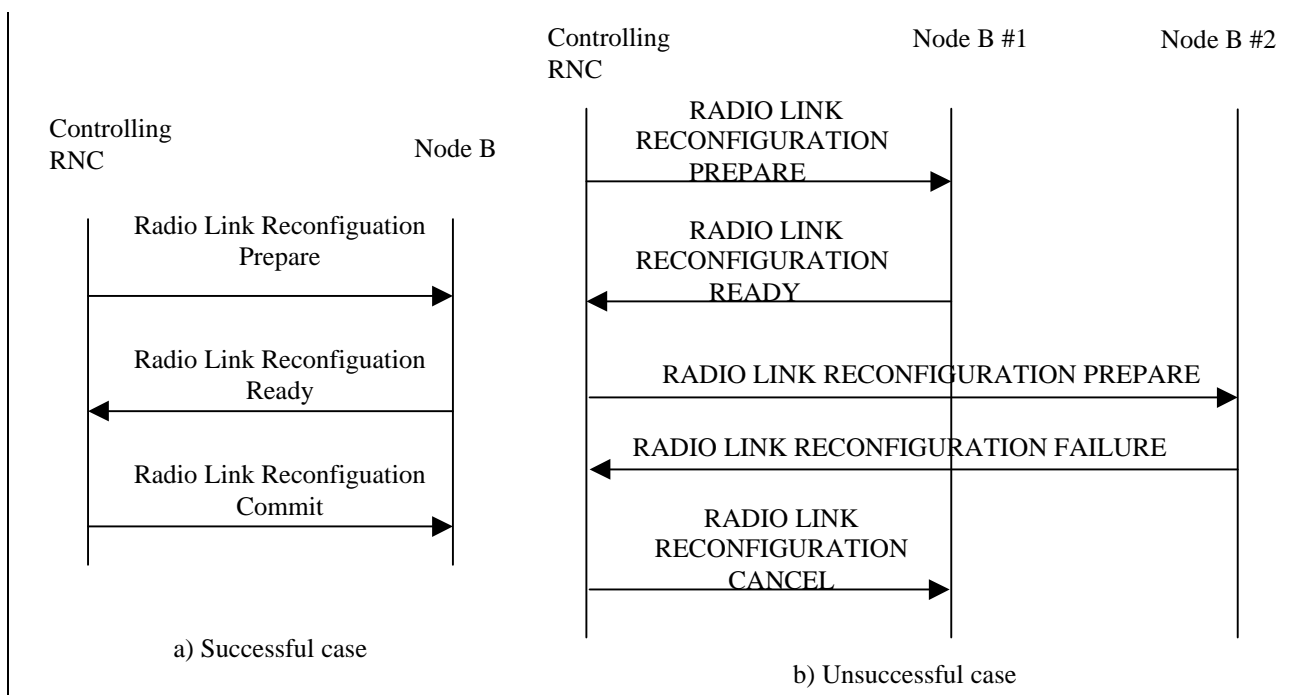

The RADIO LINK RECONFIGURATION PREPARE REQUEST message contains:

- UL Radio Resources (UL Channelisation code type)
- DL Radio Resources (DL Channelisation code per RL) (if changed)
- Transport Format Combination Set

In case of DCH addition, this message also contains

- DCH Information (new DCH ID to add, Transmission Rate, Transport Format Combination Set)
- Priority of DCH (How is it used?)

In case of DCH reconfiguration, this message also contains

- DCH Information (existing DCH ID to modify, Transmission Rate, Transport Format Combination Set)
- Priority of modified DCH (How is it used?)

In case of DCH deletion, this message also contains

- DCH Information (DCH ID to delete)

The RADIO LINK RECONFIGURATION PREPARE~~REQUEST~~ message may consist of a combination of DCH addition, deletion, and reconfiguration.

The RADIO LINK RECONFIGURATION READY~~PROCEEDING~~ message contains:

- FFS

In case of DCH addition, this message also contains

- Transport layer addressing information (AAL2 address, AAL2 binding ID) for added DCH

In case of DCH reconfiguration, this message also contains

- Transport layer addressing information (AAL2 address, AAL2 binding ID) for modified DCH (if needed)

The RADIO LINK RECONFIGURATION FAILURE message contains

- CAUSE

The RADIO LINK RECONFIGURATION COMMIT~~COMMAND~~ message contains

- Timing information to change old resource to new resource (FFS)

The RADIO LINK RECONFIGURATION CANCEL message contains

- Cancel information to reconfigure resources

Note: A mechanism for synchronising the switching from the old to the new configuration in the UE and in the Controlling RNC is needed and FFS.

#### 9.2.2.2.3 Radio Link Deletion

When the Controlling RNC is asked by Node B to delete a cell from the active set of a specific RRC connection, the message RADIO LINK DELETION ~~REQUEST~~ is sent to the corresponding Node B. The message contains essentially the Radio Link identifier of the Radio Link to be deleted. Upon reception of the message, Node B should delete immediately the radio link and all related allocations within the Node B and acknowledge the deletion to the Controlling RNC with the message RADIO LINK DELETION ~~RESPONSE~~ CONFIRM.

The Controlling RNC is responsible to release the corresponding Iub transport bearers if they are not used by other radio links.

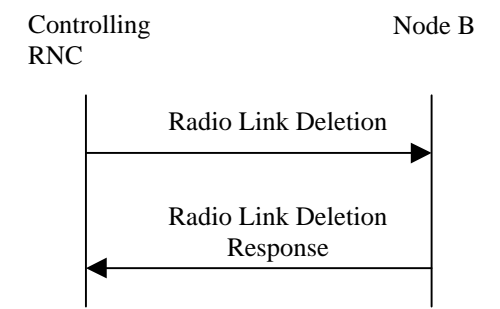

The RADIO LINK ~~DELETION~~ REQUEST message contains (the identification of the UE is FFS):

- Radio Link Identifiers (of cells to be deleted)

The RADIO LINK ~~DELETION~~ RESPONSE CONFIRM message contains:

- FFS

#### 9.2.2.2.4 DL Power Control

Note that this procedure is FFS. It is also FFS whether signalling is in-band or out-band.

The purpose of this procedure is to balance the DL transmission powers of Radio Links used for the related RRC connection within the node B. DL POWER CONTROL procedure is initiated by the Controlling RNC by sending a DL POWER CONTROL NBAP message, which contains the desired power range for the Radio Links within the node B.



#### 9.2.2.2.5 Outer Loop Power Control

Note that this procedure is FFS.

This procedure is used to provide the Node B with a new quality target value ( $E_b/I_0$ ) for the UL quality.



#### 9.2.2.2.6 Down Link Code Reconfiguration Trigger

Note that this procedure is FFS.

Down Link Code reconfiguration trigger procedure is initiated by the Node B, when it detects unwanted fragmentation in the DL spreading code pool(s). Node B sends DL CODE RECONFIGURATION REQUEST to the CRNC via the appropriate dedicated connection.

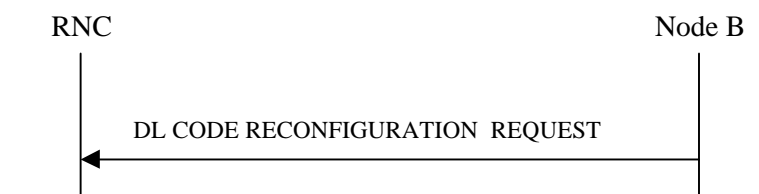

### 9.2.3 NBAP Messages

Note that the content of this chapter is FFS.

This chapter defines the structure of the messages required for the NBAP protocols.

For each message there is, a table listing the signaling elements in their order of appearance in the transmitted message.

All the NBAP messages are listed in the following table :

[Note : All of these message name are tentative, these can be changed after complete discussion]

Message name	Reference
--------------	-----------

<u>RADIO LINK SETUP</u>	<u>9.2.3.1.1</u>
<u>RADIO LINK SETUP RESPONSE</u>	<u>9.2.3.1.2</u>
<u>RADIO LINK SETUP FAILURE</u>	<u>9.2.3.1.3</u>
<u>RADIO LINK ADDITION</u>	<u>9.2.3.1.4</u>
<u>RADIO LINK ADDITION RESPONSE</u>	<u>9.2.3.1.5</u>
<u>RADIO LINK ADDITION FAILURE</u>	<u>9.2.3.1.6</u>
<u>RADIO LINK DELETION</u>	<u>9.2.3.1.7</u>
<u>RADIO LINK DELETION RESPONSE</u>	<u>9.2.3.1.8</u>
<u>RADIO LINK RECONFIGURATION PREPARE</u>	<u>9.2.3.1.9</u>
<u>RADIO LINK RECONFIGURATION READY</u>	<u>9.2.3.1.10</u>
<u>RADIO LINK RECONFIGURATION COMMIT</u>	<u>9.2.3.1.11</u>
<u>RADIO LINK RECONFIGURATION FAILURE</u>	<u>9.2.3.1.12</u>
<u>RADIO LINK RECONFIGURATION CANCEL</u>	<u>9.2.3.1.13</u>
<u>DL CODE RECONFIGURATION REQUEST</u>	<u>9.2.3.1.14</u>
<u>POWER CONTROL</u>	<u>9.2.3.1.15</u>
<u>OUTER LOOP POWER CONTROL</u>	<u>9.2.3.1.16</u>
<u>PAGING</u>	<u>9.2.3.1.17</u>
<u>RESET (FFS)</u>	<u>9.2.3.1.18</u>
<u>RESET ACKNOWLEDGE (FFS)</u>	<u>9.2.3.1.19</u>
<u>CONFUSION (FFS)</u>	<u>9.2.3.1.20</u>

### 9.2.3.1 Message Contents

**[Note: INFORMATION ELEMENT for each message shall be described in detail with each TYPE M/O.]**

#### 9.2.3.1.1 RADIO LINK SETUP

<u>INFORMATION ELEMENT</u>	<u>REFERENCE</u>	<u>DIRECTION</u>	<u>TYPE</u>	<u>LEN</u>
Link Reference		DRNC-NodeB	M	
Message Identifier			M	
Length			M	
Message Compatibility Information			M	
No. of DCHs			M	
DCH ID (# 1)			M	
TFS (for DCH ID# 1)			M	
DCH ID (# n)			M	
TFS (for DCH ID# n)			M	
TFCS (for DCHs)			M	
Radio Frequency			M	
UL scrambling code			M	
UL spreading code type			M	
No. of UL spreading code			M	
UL spreading code id(s)			M	
DL spreading code type			M	
No. of DL spreading code			M	
No. of Radio Links			M	
Radio Link ID			M	
Cell ID			M	
Phase Difference			M	
Radio Link ID			O	
Cell ID			O	
Soft Combination Indication			O	
Phase Difference			O	
Slot offset			M	

Frame offset			<u>M</u>	
Initial DL Power			<u>M</u>	
Target UL Eb/lo			<u>M</u>	

### 9.2.3.1.2 RADIO LINK SETUP RESPONSE

<u>INFORMATION ELEMENT</u>	<u>REFERENCE</u>	<u>DIRECTION</u>	<u>TYPE</u>	<u>LEN</u>
<u>Link Reference</u>		<u>NodeB-DRNC</u>	<u>M</u>	
<u>Message Identifier</u>			<u>M</u>	
<u>Length</u>			<u>M</u>	
<u>Message Compatibility Information</u>			<u>M</u>	
<u>No. of DCHs</u>			<u>M</u>	
<u>DCH ID (# 1)</u>			<u>M</u>	
<u>ATM Binding ID</u>			<u>M</u>	
<u>ATM Address</u>			<u>O</u>	
<u>DCH ID (# n)</u>			<u>M</u>	
<u>ATM Binding ID</u>			<u>M</u>	
<u>ATM Address</u>			<u>O</u>	
<u>UL Interference Level</u>			<u>M</u>	
<u>No. of Radio Links</u>			<u>M</u>	
<u>Radio Link ID</u>			<u>M</u>	
<u>Neighbor Cell Information</u>			<u>M</u>	
<u>No. of DL spreading code</u>			<u>M</u>	
<u>DL spreading code id #1</u>			<u>M</u>	
<u>DL spreading code id #m</u>			<u>M</u>	
<u>Radio Link ID</u>			<u>O</u>	
<u>Neighbor Cell Information</u>			<u>O</u>	
<u>No. of DL spreading code</u>			<u>O</u>	
<u>DL spreading code id #1</u>			<u>O</u>	
<u>DL spreading code id #m</u>			<u>O</u>	

### 9.2.3.1.3 RADIO LINK SETUP FAILURE

<u>INFORMATION ELEMENT</u>	<u>REFERENCE</u>	<u>DIRECTION</u>	<u>TYPE</u>	<u>LEN</u>
<u>Link Reference</u>		<u>NodeB-DRNC</u>	<u>M</u>	
<u>Message Identifier</u>			<u>M</u>	
<u>Length</u>			<u>M</u>	
<u>Message Compatibility Information</u>			<u>M</u>	
<u>Cause</u>			<u>M</u>	

### 9.2.3.1.4 RADIO LINK ADDITION

<u>INFORMATION ELEMENT</u>	<u>REFERENCE</u>	<u>DIRECTION</u>	<u>TYPE</u>	<u>LEN</u>
<u>Link Reference</u>		<u>DRNC-NodeB</u>	<u>M</u>	
<u>Message Identifier</u>			<u>M</u>	
<u>Length</u>			<u>M</u>	
<u>Message Compatibility Information</u>			<u>M</u>	
<u>Radio Frequency</u>			<u>O</u>	
<u>No. of Radio Links</u>			<u>M</u>	
<u>Radio Link ID</u>			<u>M</u>	
<u>Cell ID</u>			<u>M</u>	
<u>Soft Combination Indication</u>			<u>M</u>	
<u>Phase Difference</u>			<u>M</u>	
<u>Radio Link ID</u>			<u>O</u>	
<u>Cell ID</u>			<u>O</u>	
<u>Soft Combination Indication</u>			<u>O</u>	
<u>Phase Difference</u>			<u>O</u>	

## 9.2.3.1.5 RADIO LINK ADDITION RESPONSE

<u>INFORMATION ELEMENT</u>	<u>REFERENCE</u>	<u>DIRECTION</u>	<u>TYPE</u>	<u>LEN</u>
<u>Link Reference</u>		<u>NodeB-DRNC</u>	<u>M</u>	
<u>Message Identifier</u>			<u>M</u>	
<u>Length</u>			<u>M</u>	
<u>Message Compatibility Information</u>			<u>M</u>	
<u>No. of DCHs</u>			<u>M</u>	
<u>DCH ID (# 1)</u>			<u>M</u>	
<u>ATM Binding ID</u>			<u>M</u>	
<u>ATM Address</u>			<u>O</u>	
<u>DCH ID (# n)</u>			<u>M</u>	
<u>ATM Binding ID</u>			<u>M</u>	
<u>ATM Address</u>			<u>O</u>	
<u>UL Interference Level</u>			<u>O</u>	
<u>No. of Radio Links</u>			<u>M</u>	
<u>Radio Link ID</u>			<u>M</u>	
<u>Neighbor Cell Information</u>			<u>M</u>	
<u>No. of DL spreading code</u>			<u>M</u>	
<u>DL spreading code id #1</u>			<u>M</u>	
<u>DL spreading code id #m</u>			<u>M</u>	
<u>Radio Link ID</u>			<u>O</u>	
<u>Neighbor Cell Information</u>			<u>O</u>	
<u>No. of DL spreading code</u>			<u>O</u>	
<u>DL spreading code id #1</u>			<u>O</u>	
<u>DL spreading code id #m</u>			<u>O</u>	

## 9.2.3.1.6 RADIO LINK ADDITION FAILURE

<u>INFORMATION ELEMENT</u>	<u>REFERENCE</u>	<u>DIRECTION</u>	<u>TYPE</u>	<u>LEN</u>
<u>Link Reference</u>		<u>NodeB-DRNC</u>	<u>M</u>	
<u>Message Identifier</u>			<u>M</u>	
<u>Length</u>			<u>M</u>	
<u>Message Compatibility Information</u>			<u>M</u>	
<u>Cause</u>			<u>M</u>	

## 9.2.3.1.7 RADIO LINK DELETION

<u>INFORMATION ELEMENT</u>	<u>REFERENCE</u>	<u>DIRECTION</u>	<u>TYPE</u>	<u>LEN</u>
<u>Link Reference</u>		<u>DRNC-NodeB</u>	<u>M</u>	
<u>Message Identifier</u>			<u>M</u>	
<u>Length</u>			<u>M</u>	
<u>Message Compatibility Information</u>			<u>M</u>	
<u>No. of Radio Links</u>			<u>M</u>	
<u>Radio Link ID #1</u>			<u>M</u>	
<u>Radio Link ID #2</u>			<u>O</u>	

## 9.2.3.1.8 RADIO LINK DELETION RESPONSE

<u>INFORMATION ELEMENT</u>	<u>REFERENCE</u>	<u>DIRECTION</u>	<u>TYPE</u>	<u>LEN</u>
<u>Link Reference</u>		<u>NodeB-DRNC</u>	<u>M</u>	
<u>Message Identifier</u>			<u>M</u>	
<u>Length</u>			<u>M</u>	
<u>Message Compatibility Information</u>			<u>M</u>	



## 9.2.3.1.9 RADIO LINK RECONFIGURATION PREPARE

<u>INFORMATION ELEMENT</u>	<u>REFERENCE</u>	<u>DIRECTION</u>	<u>TYPE</u>	<u>LEN</u>
<u>Link Reference</u>		<u>DRNC-NodeB</u>	<u>M</u>	
<u>Message Identifier</u>			<u>M</u>	
<u>Length</u>			<u>M</u>	
<u>Message Compatibility Information</u>			<u>M</u>	
<u>No. of DCHs</u>			<u>M</u>	
<u>DCH ID (# 1)</u>		<u>For Addition</u>	<u>M</u>	
<u>TFS (for DCH ID# 1)</u>			<u>O</u>	
<u>DCH QoS</u>			<u>M</u>	
<u>DCH ID (# n)</u>			<u>O</u>	
<u>TFS (for DCH ID# n)</u>			<u>O</u>	
<u>DCH QoS</u>			<u>O</u>	
<u>TFCS (for DCHs)</u>		<u>For Reconfiguration</u>	<u>M</u>	
<u>UL spreading code type</u>			<u>M</u>	
<u>No. of UL spreading code</u>			<u>M</u>	
<u>UL spreading code id(s)</u>			<u>M</u>	
<u>DL spreading code type</u>			<u>M</u>	
<u>No. of DL spreading code</u>			<u>M</u>	
<u>No. of Radio Links</u>		<u>For Deletion</u>	<u>M</u>	
<u>Radio Link ID#1</u>			<u>M</u>	
<u>Radio Link ID#2</u>			<u>O</u>	

## 9.2.3.1.10 RADIO LINK RECONFIGURATION READY

<u>INFORMATION ELEMENT</u>	<u>REFERENCE</u>	<u>DIRECTION</u>	<u>TYPE</u>	<u>LEN</u>
<u>Link Reference</u>		<u>NodeB-DRNC</u>	<u>M</u>	
<u>Message Identifier</u>			<u>M</u>	
<u>Length</u>			<u>M</u>	
<u>Message Compatibility Information</u>			<u>M</u>	
<u>No. of DCHs</u>			<u>O</u>	
<u>DCH ID (# 1)</u>		<u>For Addition</u>	<u>O</u>	
<u>ATM Binding ID</u>			<u>O</u>	
<u>ATM Address</u>			<u>O</u>	
<u>DCH ID (# n)</u>			<u>O</u>	
<u>ATM Binding ID</u>			<u>O</u>	
<u>ATM Address</u>			<u>O</u>	
<u>No. of Radio Links</u>		<u>For Reconfiguration</u>	<u>M</u>	
<u>Radio Link ID</u>			<u>M</u>	
<u>No. of DL spreading code</u>			<u>M</u>	
<u>DL spreading code id #1</u>			<u>M</u>	
<u>DL spreading code id #m</u>			<u>M</u>	
<u>Radio Link ID</u>		<u>For Deletion</u>	<u>O</u>	
<u>No. of DL spreading code</u>			<u>O</u>	
<u>DL spreading code id #1</u>			<u>O</u>	
<u>DL spreading code id #m</u>			<u>O</u>	

## 9.2.3.1.11 RADIO LINK RECONFIGURATION COMMIT

<u>INFORMATION ELEMENT</u>	<u>REFERENCE</u>	<u>DIRECTION</u>	<u>TYPE</u>	<u>LEN</u>
<u>Link Reference</u>		<u>DRNC-NodeB</u>	<u>M</u>	
<u>Message Identifier</u>			<u>M</u>	
<u>Length</u>			<u>M</u>	
<u>Message Compatibility Information</u>			<u>M</u>	
<u>Execution Time</u>			<u>M</u>	

9.2.3.1.12 RADIO LINK RECONFIGURATION FAILURE

<u>INFORMATION ELEMENT</u>	<u>REFERENCE</u>	<u>DIRECTION</u>	<u>TYPE</u>	<u>LEN</u>
<u>Link Reference</u>		<u>NodeB-DRNC</u>	<u>M</u>	
<u>Message Identifier</u>			<u>M</u>	
<u>Length</u>			<u>M</u>	
<u>Message Compatibility Information</u>			<u>M</u>	

9.2.3.1.13 RADIO LINK RECONFIGURATION CANCEL

<u>INFORMATION ELEMENT</u>	<u>REFERENCE</u>	<u>DIRECTION</u>	<u>TYPE</u>	<u>LEN</u>
<u>Link Reference</u>		<u>DRNC-NodeB</u>	<u>M</u>	
<u>Message Identifier</u>			<u>M</u>	
<u>Length</u>			<u>M</u>	
<u>Message Compatibility Information</u>			<u>M</u>	

9.2.3.1.14 POWER CONTROL

<u>INFORMATION ELEMENT</u>	<u>REFERENCE</u>	<u>DIRECTION</u>	<u>TYPE</u>	<u>LEN</u>
<u>Link Reference</u>		<u>DRNC-NodeB</u>	<u>M</u>	
<u>Message Identifier</u>			<u>M</u>	
<u>Length</u>			<u>M</u>	
<u>Message Compatibility Information</u>			<u>M</u>	
<u>DL Power Range</u>			<u>M</u>	

9.2.3.1.15 OUTER LOOP POWER CONTROL

<u>INFORMATION ELEMENT</u>	<u>REFERENCE</u>	<u>DIRECTION</u>	<u>TYPE</u>	<u>LEN</u>
<u>Link Reference</u>		<u>DRNC-NodeB</u>	<u>M</u>	
<u>Message Identifier</u>			<u>M</u>	
<u>Length</u>			<u>M</u>	
<u>Message Compatibility Information</u>			<u>M</u>	
<u>Target UL Eb/lo</u>			<u>M</u>	

9.2.3.1.16 DL CODE RECONFIGURATION REQUEST

<u>INFORMATION ELEMENT</u>	<u>REFERENCE</u>	<u>DIRECTION</u>	<u>TYPE</u>	<u>LEN</u>
<u>Link Reference</u>		<u>NodeB-DRNC</u>	<u>M</u>	
<u>Message Identifier</u>			<u>M</u>	
<u>Length</u>			<u>M</u>	
<u>Message Compatibility Information</u>			<u>M</u>	

9.2.3.1.17 PAGING

<u>INFORMATION ELEMENT</u>	<u>REFERENCE</u>	<u>DIRECTION</u>	<u>TYPE</u>	<u>LEN</u>
<u>Paged UE Identifier</u>		<u>DRNC-NodeB</u>	<u>M</u>	
<u>Link Reference</u>			<u>M</u>	
<u>Message Identifier</u>			<u>M</u>	
<u>Length</u>			<u>M</u>	
<u>LAI</u>			<u>M</u>	
<u>Group number of Incoming Call</u>			<u>M</u>	

9.2.3.1.18 RESET (FFS)9.2.3.1.19 RESET ACKNOWLEDGE (FFS)9.2.3.1.20 CONFUSION (FFS)9.2.4 Signalling Element Coding

Note that the content of this chapter is FFS.

This paragraph contains the CODING of the signaling elements used.

The following convention are assumed for the sequence of transmission of bits and bytes:

Each bit position is marked as 1 to 8. Bit 1 is the least significant bit and is transmitted first.

In an element octets are identified by number, octet 1 is transmitted first, then octet 2 etc.

Length Indicator

It is desirable to have Length for messages and parameters because future version of protocol may have extension to the present message or parameter, and also variable size can be present in some parameters as well.

In case of message size exceeding 256 byte it is better to have 2 bytes for message LENGTH.

However it is enough to have 1 byte for parameter LENGTH.

Compatibility Information

Compatibility Information is used in the situation of unrecognized messages or parameter. This parameter should be placed at a certain place then it is easy to pick up this parameter in any circumstances.

Consequently, the format can be as follow:

Message Identifier / Length / Compatibility Info / parameters

Parameter Identifier / Length / Compatibility Info / Fields

Figure 3 shows the coding format of message and Figure 4 shows the coding format of parameter.

Fixed size data and Variable size data in Field

It may have two types of field i.e. with variable size or fixed size in data of field. It has no any problem to specify the fixed size field. Figure5 shows an example of fixed size data in field.

Regarding the variable size of data

The elements used and their CODING are:

<u>Element Identifier Coding</u>	<u>Element name</u>	<u>Reference</u>
	<u>ATM Binding ID</u>	
	<u>ATM Address</u>	
	<u>No of DCHs</u>	
	<u>DCH ID</u>	
	<u>TFS(for DCH)</u>	
	<u>TFCS(for DCHs)</u>	
	<u>Radio Frequency</u>	
	<u>UL scrambling code</u>	
	<u>UL spreading code type</u>	
	<u>No. of UL spreading code</u>	
	<u>UL spreading code ID</u>	
	<u>UL Interference Level</u>	
	<u>DL spreading code type</u>	
	<u>No. of DL spreading code</u>	
	<u>DL spreading code id</u>	
	<u>Cell ID</u>	
	<u>Neighbor Cell Information</u>	
	<u>Soft Combination Indication</u>	
	<u>Phase Difference</u>	
	<u>Radio Link ID</u>	
	<u>No. of Radio Links</u>	
	<u>Execution Time</u>	
	<u>Slot offset</u>	
	<u>Frame offset</u>	
	<u>Initial DL Power</u>	
	<u>DL Power Range</u>	
	<u>Target UL Eb/lo</u>	
	<u>DCH QoS</u>	
	<u>LAI</u>	
	<u>Group number of incoming call</u>	
	<u>Cause</u>	

## Message Identifier

Message Identifier uniquely identifies the message being sent. It is a single octet element, mandatory in all messages.

8765 4321	
	<u>RADIO LINK SETUP</u> <u>RADIO LINK SETUP RESPONSE</u> <u>RADIO LINK SETUP FAILURE</u>
	<u>RADIO LINK ADDITION</u> <u>RADIO LINK ADDITION RESPONSE</u> <u>RADIO LINK ADDITION FAILURE</u>
	<u>RADIO LINK DELETION</u> <u>RADIO LINK DELETION RESPONSE</u>
	<u>RADIO LINK RECONFIGURATION PREPARE</u> <u>RADIO LINK RECONFIGURATION READY</u> <u>RADIO LINK RECONFIGURATION COMMIT</u> <u>RADIO LINK RECONFIGURATION FAILURE</u> <u>RADIO LINK RECONFIGURATION CANCEL</u>
	<u>POWER CONTROL</u>
	<u>OUTER LOOP POWER CONTROL</u>
	<u>DL CODE RECONFIGURATION REQUEST</u>
	<u>PAGING</u>
	<u>RESET (FFS)</u>
	<u>RESET ACKNOWLEDGE (FFS)</u>
	<u>RESET (FFS)</u>

## Message Compatibility Information

Message Compatibility Information is used in the situation of unrecognized messages.

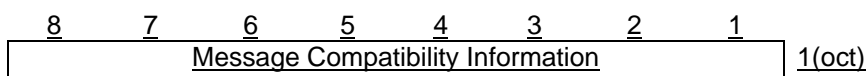

Figure: Message Compatibility Information

Table: Message Compatibility Information octet

Bit	
<u>8</u>	<u>Reserved</u>
:	
<u>4</u>	<u>Pass On not possible</u>
<u>3</u>	<u>Discard Message</u>
<u>2</u>	<u>Send Notify (1)</u>
<u>1</u>	<u>Release Indicator</u>

1. It should be used in CONFUSION message

## Parameter Compatibility Information

Parameter Compatibility Information is used in the situation of unrecognized messages.

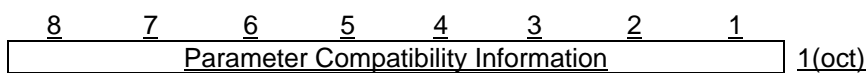

Figure: Parameter Compatibility Information

Table: Parameter Compatibility Information octet ( The detail is FFS.)

Bit	
<u>8</u>	<u>Reserved</u>
:	
<u>4</u>	<u>Pass On not possible</u>

3	<u>Discard Message</u>
2	<u>Send Notify (1)</u>
1	<u>Release Indicator</u>

1. It should be used in CONFUSION message

ATM Address

This element is included ATM address.

[Note: The following should be described the cording format.(The detail is FFS.)]

ATM Binding ID

This element is included ATM Binding ID.

[Note: The following should be described the cording format.(The detail is FFS.)]

Cell ID

This element uniquely identifies cell which a RNC and is of variable length containing.

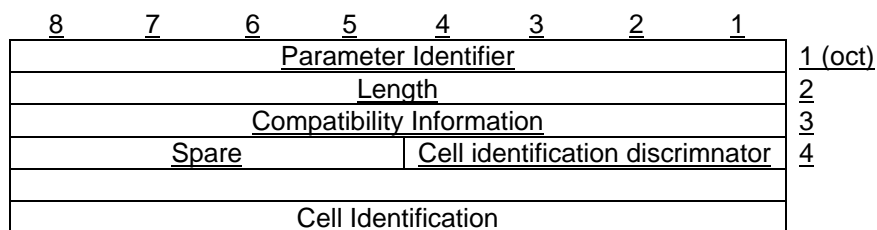

Figure: format of Cell Identifier

Neibor Cell information

No of DCHs

DCH ID

TFS(for DCH)

TFCS(for DCHs)

Soft Combination Indication

Phase Difference

Radio Frequency

UL Interference level

UL scrambling code

UL spreading code type

No. of UL spreading codes

UL spreading code ID

DL spreading code type

No. of Radio Links

Radio Link ID

No. of DL spreading codes

DL spreading code ID

Execution Timer

Initial DL Power

DL Power Range

This Information element defines the DL transmission power range to be used for the radio links used for the related RRC connection in the node-B.

Target UL Eb/lo

Slot Offset

Frame OffsetDCH QoSLAIGroup number of incoming callCause

This element is used to indicate the reason for a particular event to have occurred and is coded as shown below.

The cause value is a single octet element if the extension bit (bit 8) is set to 0. If it is set to 1 then the cause value is a 2octet field.

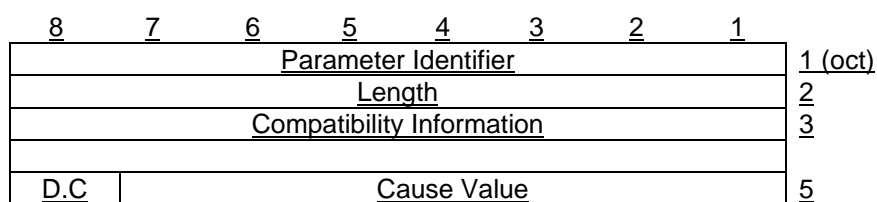

Figure: format of Cause

Cause Value:

Class : Normal event

Class: Normal event

Class: Resource unavailable

Class : Service or option not available

Class : Service or option not implemented

Class : invalid message (eg parameter out of range)

Class : protocol error

Class : interworking

The following table shows example of cause value.

Table: cause value

<u>Cause Value</u>		
<u>Class</u>	<u>value</u>	
<u>765</u>	<u>4321</u>	
		<u>Normal termination</u> <u>Mobile illegal (ex. Authentication NG)</u> <u>O &amp; M intervention</u> <u>Equipment failure</u> <u>Protocol error</u> <u>Message type non-existent or not implemented</u> <u>Information element/parameter non-existent or not implemented</u> <u>Radio link failure</u> <u>BS approach link failure</u> <u>Timer expired</u> <u>Ciphering algorithm not supported</u> <u>Resource unavailable</u> <u>Other values are reserved</u>



## 9.3 Transport Layer

### 9.3.1 General

*[Editor's note: This chapter should e.g. describe Radio Network Layer requirements on Transport Layer protocols.]*

### 9.3.2 Signalling Bearer

The Signalling Bearer for the NBAP is a point-to-point protocol. There may be multiple point-to-point links between an RNC and a Node B.

Two alternatives have been identified for the signalling bearer in the Radio Network Control Plane, SAAL-UNI over ATM and TCP/IP / AAL5. The current working assumption is to use SAAL-UNI as the signalling bearer for NBAP.

## 10. I<sub>ub</sub>-Interface Protocol Layer Specification for Transport Network Control Plane

### 10.1 Introduction

*[Editor's note: This chapter should describe general requirements and structure of the Transport Network Control Plane.]*

### 10.2 Transport Layer

#### 10.2.1 General

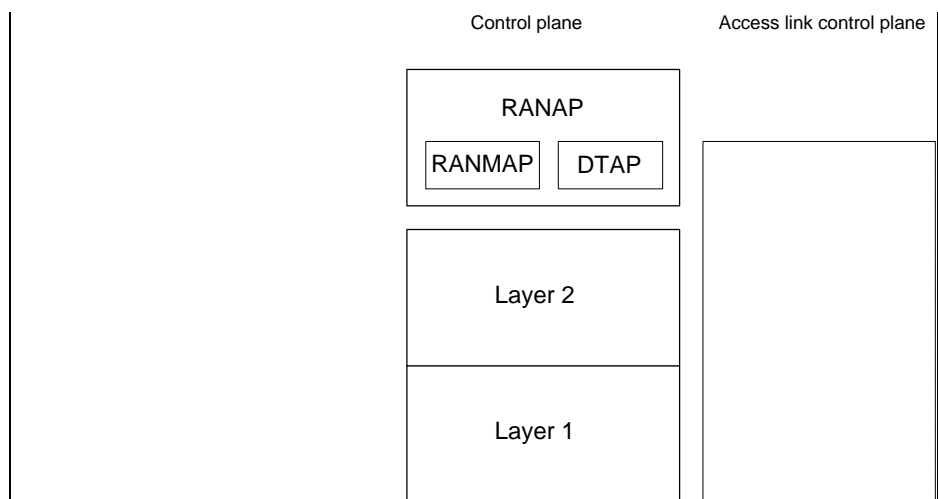

Figure 2: Transport Network Control plane protocol structure on Iub.

#### 10.2.2 ALCAP

Working assumption: Q.aal2 under development by ITU SG11 [9] is selected as that standard AAL2 signalling protocol for Iub.

### 10.2.3 Signalling Bearer

Working assumption: SAAL-UNI is the standard signalling bearer for the AAL Type Signalling protocol (Q.aal2) on Iub.

## 11. I<sub>ub</sub> -Interface Protocol Layer Specification for User Plane

### 11.1 Introduction

*[Editor's note: This chapter should describe the structure of the User Plane.*

*The description of the structure of I<sub>ur</sub> and I<sub>ub</sub> data frames is included here, but not in [4]. The I<sub>ur</sub> data stream shall follow the same specification as the I<sub>ub</sub> data stream [1].]*

### 11.2 Radio Network Layer

#### 11.2.1 General

*[Editor's note: This chapter should describe structure of I<sub>ub</sub> data streams]*

For the user plane of the radio network layer there are four protocols:

- Dedicated Channel Frame Protocol (DCH FP) for transport of Iub data streams carried on dedicated channels on the Uu-interface.
- Random Access Channel Frame Protocol (RACH FP) for transport of Iub data streams carried on RACH on the Uu-interface.
- Forward Access Channel Frame Protocol (FACH FP) for transport of Iub data streams carried on FACH on the Uu-interface.
- Downlink Shared Channel Frame Protocol (DSCH FP) for transport of Iub data streams carried on DSCH on the Uu-interface.

Note: FAUSCH frame protocol is FFS (depending on the decision of Layer 1 Expert Group).

#### 11.2.2 Dedicated Channel Frame Protocol

The specification of I<sub>ub</sub> DCH data streams is also valid for I<sub>ur</sub> DCH data streams.

The parameters to be included in the Iub frames to be transported between Node B and Serving RNC (i.e., they apply for I<sub>ur</sub> and Iub data stream) are:

1. **User data** - a block of user data.
2. **Connection ID** - used by soft combining function to identify multiple paths of the same call.
3. **Quality Indication** - used by soft combining function.
4. **Length Indicator** - used to allow different frame sizes and different user rates.
5. **CRC** - error check for the frame.
6. **Rx power** - indication of received power level in uplink only.
7. **Frame Type** - e.g. signalling or data.

8. **CFN** – the connection frame number is the indicator as to which radio frame the data should be transmitted / was received. It is also needed for synchronisation purposes in DL channel frames.
9. **Timing adjustment command** – needed for synchronisation purposes in UL channel frames.

*[Note: This list of parameters is the starting assumption and not necessarily comprehensive.]*

Two different message types are to be used for both the downlink and uplink DCH Transport Channel Frame protocol in the Iur and Iub interfaces.

- DCH data frame
- DCH control frame

The DCH control frame shall be used for inband signalling between SRNC and Node B in cases where the normal DCH data frame can not be utilised. The DCH control frame shall not carry any data targeted to or received from the air interface. Typical use for the DCH control frame would be synchronisation of the user plane and transport of DL outer loop power control commands.

### 11.2.2.1 Dedicated Channel Procedures

#### 11.2.2.1.1 General

The SRNC is responsible for creating communications inside the SRNS. The SRNC provides to the Node B the complete configuration of the Transport channels to be provided by the Node B for a given communication. The parameters of a Transport channel are described in [6]. These Transport channels are multiplexed on the downlink by the Node B on radio physical channels, and de-multiplexed on the uplink from radio physical channels to Transport channels.

Every Transport channel related to one UE context that is communicated over a set of cells that are macro-diversity combined within Node B, is carried on one AAL2 connection. This means that there are as many AAL2 connections as Transport channels and User ports for that communication.

It is FFS whether unidirectional or bi-directional AAL2 connections are used.

#### 11.2.2.1.2 Downlink Transfer

Every Transmission Time Period (typically one radio frame, i.e. 10ms), for each Transport channel, the SRNC provides to the Node B the following information:

- a Transport Bloc Set (user data) to be sent on the radio interface
- the Transport Format Indicator (TFI) to use

The CID of the AAL2 frame identifies the Iub data stream where a Transport channel frame is transported.

Information element	Description
message type	Downlink DCH Transport channel frame
Transport Format Indicator	The TFI identifies the format of the transport channel to be used on the radio interface
Transport Bloc Set	This contains the data to be sent on the radio interface
Outer Loop Power Control (optional)	This may update the target outer loop power control

#### 11.2.2.1.3 Uplink Transfer

Every Transmission Time Period (typically one radio frame, i.e. 10ms), for each Transport channel, the Node B sends to the SRNC the following information:

- a Transport Bloc Set (user data) received from the radio interface

- the Transport Format Indicator (TFI) associated to the Transport Bloc Set
- A Quality indicator:  
Bad / Good frame

Other Quality indications are FFS.

When the frame is incorrectly received, it is not sent on the Iur interface.

Information element	Description
message type	Uplink DCH Transport channel frame
Transport Format Indicator	The TFI identifies the format of the transport channel as received from the radio interface
Transport Bloc Set	This contains the data received from the radio interface
Quality indicator	This may update the target outer loop power control

### 11.2.2.2 Iur / Iub DCH Data Stream Synchronisation

To synchronise and keep the synchronisation of a DCH data stream SRNC includes a Connection Frame Number (CFN) to all DL DCH Transport channel frames. If there is no data to be transmitted to the UE via the DCH transport bearer then a special DL DCH Control frames can be sent instead of DL DCH data frames.

Upon reception of a DL DCH Transport channel frame, node B should evaluate the time difference between the optimal arrival time for the DL DCH Transport Channel frame to be transmitted in the indicated CFN and the actual measured arrival time of the DL DCH Transport channel frame.

According to the measured time difference, node B should set a proper value for the Timing adjustment command in the UL DCH transport channel frame. If there is no UL data to be transmitted to the SRNC via the DCH transport bearer then a special UL DCH Control frame can be sent.

(The initial value for the parameters is FFS)

### 11.2.3 FACH Frame Protocol

The parameters to be included in the Iub FACH frames are:

1. **CELL FN** – the cell frame number is needed for synchronisation purposes.

### 11.2.4 RACH Frame Protocol

The parameters to be included in the Iub RACH frames are:

1. **CELL FN** – the cell frame number is needed for synchronisation purposes.

### 11.2.5 DSCH Frame Protocol

## 11.3 Transport Layer

*[Editor's note: This chapter should refer to specifications of the Transport Layer protocol(s). Limitations in usage of options of the protocol(s) should be described.]*

| Iub / Iur DCH data stream for soft handover [FDD]:

ATM and AAL2 is used as a standard transport layer for DCH data streams across the Iur and Iub interfaces. Other protocols such as Frame Relay and ATM AAL5 are FFS.

Iub / Iur DCH data stream for soft handover [TDD]:  
FFS

ATM and AAL2 type 2 (I363.2 and I366.1) is used at the standard transport layer for Iub RACH and FACH data streams.

Note: This assumes that MAC scheduling is in the RNC. This decision is to be confirmed when protocol termination points are decided.

## 12. Physical Layer

*[Editor's note: This chapter should refer to specifications of the Physical Layer. Limitations in usage of options of the protocol(s) should be described.]*

Working assumption:

When using multiple low speed links in the Iub interface, the Node B shall support IMA (Inverse Multiplexing for ATM).

## 13. Example Sequences

*[Editor's note: This chapter should contain examples of sequences including both Radio Network Signalling and Transport Signalling.]*

## 14. History

Document history		
Date	Version	Comment
February 4, 1999	0.0.1	First draft of merged Iub description document
Urs Bernhard Lucent Technologies  Tel. : +49 911 526 2728 Fax : +49 911 526 3856 Email : <a href="mailto:u.bernhard@lucent.com">Error! Bookmark not defined.u.bernhard@lucent.com</a>		
This document is written in Microsoft Word version 7.0/97.		

---

## ANNEX Iub Parameters List

**Note: The entire Annex is FFS.**

### **Paging**

<u>Parameter Category</u>	<u>Iub Parameters</u>	<u>Iub Message</u>	<u>Note</u>
		<u>PAGING</u>	
<u>LAI</u>	<u>LAI</u>	<u>m</u>	
<u>Group No. of Incoming Call</u>	<u>Group No. of Incoming Call</u>	<u>m</u>	

**RRC Connection Setup**

Parameter Category	Sub Parameters	Sub Message			Note
		<u>IDLE to DCH</u>			
		<u>RA</u> <u>DIO</u> <u>LIN</u> <u>K</u> <u>SET</u> <u>UP</u>	<u>RA</u> <u>DIO</u> <u>LIN</u> <u>K</u> <u>SET</u> <u>UP</u> <u>RES</u> <u>PO</u> <u>NSE</u>	<u>RA</u> <u>DIO</u> <u>LIN</u> <u>K</u> <u>SET</u> <u>UP</u> <u>FAI</u> <u>LUR</u> <u>E</u>	
<u>Transport CH Info</u>	<u>No. of DCHs</u>	<u>m</u>	<u>-</u>	<u>-</u>	
	<u>DCH ID (# 1)</u>	<u>m</u>	<u>-</u>	<u>-</u>	<u>DCH ID or each DCH</u>
	<u>TFS (for DCH ID# 1)</u>	<u>m</u>	<u>-</u>	<u>-</u>	<u>Set TFS when it is required</u>
	<u>:</u>				
	<u>DCH ID (# n)</u>	<u>m</u>	<u>-</u>	<u>-</u>	
	<u>TFS (for DCH ID# n)</u>	<u>m</u>	<u>-</u>	<u>-</u>	
	<u>TFCS (for DCHs)</u>	<u>m</u>	<u>-</u>	<u>-</u>	<u>Set TFCS per UE</u>
<u>Transport Layer Addressing Information</u>	<u>No. of DCHs</u>	<u>-</u>	<u>m</u>	<u>-</u>	
	<u>DCH ID (# 1)</u>	<u>-</u>	<u>m</u>	<u>-</u>	
	<u>ATM Binding ID</u>	<u>-</u>	<u>m</u>	<u>-</u>	<u>(TTC) 1 Binding ID for 1 DCH *1</u>
	<u>ATM Address</u>	<u>-</u>	<u>o</u>	<u>-</u>	
	<u>:</u>				
	<u>DCH ID (# n)</u>	<u>-</u>	<u>m</u>	<u>-</u>	
	<u>ATM Binding ID</u>	<u>-</u>	<u>m</u>	<u>-</u>	
	<u>ATM Address</u>	<u>-</u>	<u>o</u>	<u>-</u>	
<u>Radio Frequency Info</u>	<u>Radio Frequency</u>	<u>m</u>	<u>-</u>	<u>-</u>	<u>Set Radio Frequency per UE</u>
	<u>UL Interference Level</u>	<u>-</u>	<u>m</u>	<u>-</u>	
<u>UL Radio Resources</u>	<u>UL scrambling code</u>	<u>m</u>	<u>-</u>	<u>-</u>	<u>Set UL Scrambling Code per UE</u>
	<u>UL spreading code type</u>	<u>m</u>	<u>-</u>	<u>-</u>	
	<u>No. of UL spreading code</u>	<u>m</u>	<u>-</u>	<u>-</u>	
	<u>UL spreading code id(s)</u>	<u>m</u>	<u>-</u>	<u>-</u>	
<u>DL Radio Resources</u>	<u>DL spreading code type</u>	<u>m</u>	<u>-</u>	<u>-</u>	<u>Same code type for all Radio Links</u>
	<u>No. of DL spreading code</u>	<u>m</u>	<u>-</u>	<u>-</u>	<u>Same number of codes for all Radio Links</u>

	<u>No. of Radio Links</u>	<u>m</u>	-	-	
	<u>Radio Link ID</u>	<u>m</u>	-	-	
	<u>Cell ID</u>	<u>m</u>	-	-	
	<u>Soft Combination Indicator</u>	-	-	-	<u>Indicates May, Must, Must not</u>
	<u>Phase Difference</u>	<u>m</u>	-	-	
	<u>:</u>				
	<u>Radio Link ID</u>	<u>o</u>	-	-	
	<u>Cell ID</u>	<u>o</u>	-	-	
	<u>Soft Combination Indicator</u>	<u>o</u>	-	-	
	<u>Phase Difference</u>	<u>o</u>	-	-	
<u>DL Radio Resources</u>	<u>No. of Radio Links</u>	-	<u>m</u>	-	
	<u>Radio Link ID</u>	-	<u>m</u>	-	
	<u>Neighbor Cell Information</u>	-	<u>m</u>	-	<b>FFS*2</b>
	<u>No. of DL spreading code</u>	-	<u>m</u>	-	
	<u>DL spreading code id #1</u>	-	<u>m</u>	-	
	<u>:</u>				
	<u>DL spreading code id #m</u>	-	<u>m</u>	-	
	<u>:</u>				
	<u>Radio Link ID</u>	-	<u>o</u>	-	
	<u>Neighbor Cell Information</u>	-	<u>o</u>	-	<b>FFS</b>
	<u>No. of DL spreading code</u>	-	<u>o</u>	-	
	<u>DL spreading code id #1</u>	-	<u>o</u>	-	
	<u>:</u>				
	<u>DL spreading code id #m</u>	-	<u>o</u>	-	
<u>Execution Time</u>	<u>Execution Time</u>	-	-	-	
<u>Offset Values</u>	<u>Slot offset</u>	<u>m</u>	-	-	
	<u>Frame offset</u>	<u>m</u>	-	-	
<u>Power Control Info</u>	<u>Initial DL Power</u>	<u>m</u>	-	-	<u>For Initial DL Power Setting</u>
	<u>DL Power Range</u>	-	-	-	<u>For Correcting DL Power Drifting during DHO</u>
<u>Outerloop Power Control Info</u>	<u>Target UL Eb/lo</u>	<u>m</u>	-	-	<u>For L1 Power Control</u>
<u>Cause</u>	<u>Cause</u>	-	-	<u>m</u>	

m: mandatory, o: optional

\*1: In TTC assumption, in the case of intra RFTR RL addition in intra-frequency, it is always soft combined in RFTR. Also in the case of intra RFTR RL addition in inter-frequency, same lub ATM connection is used. Therefore, in case of RADIO LINK ADDITION resp.conf.(Inter RFTR), RFTR send existing binding ID to RACFd.

\*2: Contents of this information is FFS. It is related to BS addressing scheme.





	ATM Address	-	o	-	-	o	-	-	-	-	-	
Radio Frequency Info	Radio Frequency	m	-	-	-	-	-	-	-	-	-	Set Radio Frequency per UE
	UL Interference Level	-	m	-	-	-	-	-	-	-	-	
UL Radio Resources	UL scrambling code	m	-	-	-	-	-	-	-	-	-	Set UL Scrambling Code per UE
	UL spreading code type	m	-	-	m	-	-	-	-	-	-	
	No. of UL spreading code	m	-	-	m	-	-	-	-	-	-	
	UL spreading code id(s)	m	-	-	m	-	-	-	-	-	-	
DL Radio Resources	DL spreading code type	m	-	-	m	-	-	-	-	-	-	Same code type for all Radio Links
	No. of DL spreading code	m	-	-	m	-	-	-	-	-	-	Same number of codes for all Radio Links
	No. of Radio Links	m	-	-	m	-	-	-	-	m	-	
	Radio Link ID	m	-	-	m	-	-	-	-	m	-	
	Cell ID	m	-	-	-	-	-	-	-	-	-	
	Soft Combination Indicator	-	-	-	-	-	-	-	-	-	-	Indicates May, Must, Must not
	Phase Difference	m	-	-	-	-	-	-	-	-	-	
	_____:											
	Radio Link ID	o	-	-	o	-	-	-	-	o	-	
	Cell ID	o	-	-	-	-	-	-	-	-	-	
	Soft Combination Indicator	o	-	-	-	-	-	-	-	-	-	
	Phase Difference	o	-	-	-	-	-	-	-	-	-	
DL Radio Resources	No. of Radio Links	-	m	-	-	m	-	-	-	-	-	
	Radio Link ID	-	m	-	-	m	-	-	-	-	-	
	Neighbor Cell Information	-	m	-	-	-	-	-	-	-	-	FFS*2
	No. of DL spreading code	-	m	-	-	m	-	-	-	-	-	
	DL spreading code id #1	-	m	-	-	m	-	-	-	-	-	
	_____:											
	DL spreading code id #m	-	m	-	-	m	-	-	-	-	-	
	_____:											
	Radio Link ID	-	o	-	-	o	-	-	-	-	-	
	Neighbor Cell Information	-	o	-	-	-	-	-	-	-	-	FFS
	No. of DL spreading code	-	o	-	-	o	-	-	-	-	-	
	DL spreading code id #1	-	o	-	-	o	-	-	-	-	-	
	_____:											
	DL spreading code id #m	-	o	-	-	o	-	-	-	-	-	
Execution Time	Execution Time	-	-	-	-	-	m	-	-	-	-	

<u>Offset Values</u>	<u>Slot offset</u>	<u>m</u>	-	-	-	-	-	-	-	-	-	
	<u>Frame offset</u>	<u>m</u>	-	-	-	-	-	-	-	-	-	
<u>Power Control Info</u>	<u>Initial DL Power</u>	<u>m</u>	-	-	-	-	-	-	-	-	-	<u>For Initial DL Power Setting</u>
	<u>DL Power Range</u>	-	-	-	-	-	-	-	-	-	-	<u>For Correcting DL Power Drifting during DHO</u>
<u>Outerloop Power Control Info</u>	<u>Target UL Eb/lo</u>	<u>m</u>	-	-	-	-	-	-	-	-	-	<u>For L1 Power Control</u>
<u>Cause</u>	<u>Cause</u>	-	-	<u>m</u>	-	-	-	<u>m</u>	-	-	-	

\*1,\*2: Same as the previous.

**RAB Reconfiguration**

Parameter Category	Sub Parameters	Sub Message					Note
		<b>DCH to DCH</b>					
		<u>RA</u>	<u>RA</u>	<u>RA</u>	<u>RA</u>	<u>RA</u>	
		<u>DIO</u>	<u>DIO</u>	<u>DIO</u>	<u>DIO</u>	<u>DIO</u>	
		<u>LIN</u>	<u>LIN</u>	<u>LIN</u>	<u>LIN</u>	<u>LIN</u>	
		<u>K</u>	<u>K</u>	<u>K</u>	<u>K</u>	<u>K</u>	
		<u>RE</u>	<u>RE</u>	<u>RE</u>	<u>RE</u>	<u>RE</u>	
		<u>CO</u>	<u>CO</u>	<u>CO</u>	<u>CO</u>	<u>CO</u>	
		<u>NFI</u>	<u>NFI</u>	<u>NFI</u>	<u>NFI</u>	<u>NFI</u>	
		<u>GU</u>	<u>GU</u>	<u>GU</u>	<u>GU</u>	<u>GU</u>	
		<u>RAT</u>	<u>RAT</u>	<u>RAT</u>	<u>RAT</u>	<u>RAT</u>	
		<u>ION</u>	<u>ION</u>	<u>ION</u>	<u>ION</u>	<u>ION</u>	
		<u>PRE</u>	<u>REA</u>	<u>CO</u>	<u>FAI</u>	<u>CA</u>	
		<u>PAR</u>	<u>DY</u>	<u>MMI</u>	<u>LUR</u>	<u>NC</u>	
		<u>E</u>		<u>I</u>	<u>E</u>	<u>EL</u>	
						<u>(FF</u>	
						<u>S)</u>	
<u>Transport CH Info</u>	<u>No. of DCHs</u>	<u>m</u>	<u>-</u>	<u>-</u>	<u>-</u>	<u>-</u>	
	<u>DCH ID (# 1)</u>	<u>m</u>	<u>-</u>	<u>-</u>	<u>-</u>	<u>-</u>	<u>DCH ID or each DCH</u>
	<u>TFS (for DCH ID# 1)</u>	<u>m</u>	<u>-</u>	<u>-</u>	<u>-</u>	<u>-</u>	<u>Set TFS when it is required</u>
	<u>:</u>						
	<u>DCH ID (# n)</u>	<u>m</u>	<u>-</u>	<u>-</u>	<u>-</u>	<u>-</u>	
	<u>TFS (for DCH ID# n)</u>	<u>m</u>	<u>-</u>	<u>-</u>	<u>-</u>	<u>-</u>	
	<u>TFCS (for DCHs)</u>	<u>m</u>	<u>-</u>	<u>-</u>	<u>-</u>	<u>-</u>	<u>Set TFCS per UE</u>
<u>Transport Layer Addressing Information</u>	<u>No. of DCHs</u>	<u>-</u>	<u>m</u>	<u>-</u>	<u>-</u>	<u>-</u>	
	<u>DCH ID (# 1)</u>	<u>-</u>	<u>m</u>	<u>-</u>	<u>-</u>	<u>-</u>	
	<u>ATM Binding ID</u>	<u>-</u>	<u>m</u>	<u>-</u>	<u>-</u>	<u>-</u>	<u>(TTC) 1 Binding ID for 1 DCH *1</u>
	<u>ATM Address</u>	<u>-</u>	<u>o</u>	<u>-</u>	<u>-</u>	<u>-</u>	
	<u>:</u>						
	<u>DCH ID (# n)</u>	<u>-</u>	<u>m</u>	<u>-</u>	<u>-</u>	<u>-</u>	
	<u>ATM Binding ID</u>	<u>-</u>	<u>m</u>	<u>-</u>	<u>-</u>	<u>-</u>	
	<u>ATM Address</u>	<u>-</u>	<u>o</u>	<u>-</u>	<u>-</u>	<u>-</u>	
<u>Radio Frequency Info</u>	<u>Radio Frequency</u>	<u>-</u>	<u>-</u>	<u>-</u>	<u>-</u>	<u>-</u>	<u>Set Radio Frequency per UE</u>
	<u>UL Interference Level</u>	<u>-</u>	<u>-</u>	<u>-</u>	<u>-</u>	<u>-</u>	
<u>UL Radio Resources</u>	<u>UL scrambling code</u>	<u>-</u>	<u>-</u>	<u>-</u>	<u>-</u>	<u>-</u>	<u>Set UL Scrambling Code per UE</u>

	<u>UL spreading code type</u>	<u>m</u>	-	-	-	-	
	<u>No. of UL spreading code</u>	<u>m</u>	-	-	-	-	
	<u>UL spreading code id(s)</u>	<u>m</u>	-	-	-	-	
<u>DL Radio Resources</u>	<u>DL spreading code type</u>	<u>m</u>	-	-	-	-	<u>Same code type for all Radio Links</u>
	<u>No. of DL spreading code</u>	<u>m</u>	-	-	-	-	<u>Same number of codes for all Radio Links</u>
	<u>No. of Radio Links</u>	<u>m</u>	-	-	-	-	
	<u>Radio Link ID</u>	<u>m</u>	-	-	-	-	
	<u>Cell ID</u>	-	-	-	-	-	
	<u>Soft Combination Indicator</u>	-	-	-	-	-	<u>Indicates May, Must, Must not</u>
	<u>Phase Difference</u>	-	-	-	-	-	
	<u>:</u>						
	<u>Radio Link ID</u>	<u>o</u>	-	-	-	-	
	<u>Cell ID</u>	-	-	-	-	-	
	<u>Soft Combination Indicator</u>	-	-	-	-	-	
	<u>Phase Difference</u>	-	-	-	-	-	
<u>DL Radio Resources</u>	<u>No. of Radio Links</u>	-	<u>m</u>	-	-	-	
	<u>Radio Link ID</u>	-	<u>m</u>	-	-	-	
	<u>Neighbor Cell Information</u>	-	-	-	-	-	<b>FFS*2</b>
	<u>No. of DL spreading code</u>	-	<u>m</u>	-	-	-	
	<u>DL spreading code id #1</u>	-	<u>m</u>	-	-	-	
	<u>:</u>						
	<u>DL spreading code id #m</u>	-	<u>m</u>	-	-	-	
	<u>:</u>						
	<u>Radio Link ID</u>	-	<u>o</u>	-	-	-	
	<u>Neighbor Cell Information</u>	-	-	-	-	-	<b>FFS</b>
	<u>No. of DL spreading code</u>	-	<u>o</u>	-	-	-	
	<u>DL spreading code id #1</u>	-	<u>o</u>	-	-	-	
	<u>:</u>						
	<u>DL spreading code id #m</u>	-	<u>o</u>	-	-	-	
<u>Execution Time</u>	<u>Execution Time</u>	-	-	<u>m</u>	-	-	
<u>Offset Values</u>	<u>Slot offset</u>	-	-	-	-	-	
	<u>Frame offset</u>	-	-	-	-	-	
<u>Power Control Info</u>	<u>Initial DL Power</u>	-	-	-	-	-	<u>For Initial DL Power Setting</u>
	<u>DL Power Range</u>	-	-	-	-	-	<u>For Correcting DL Power Drifting during DHO</u>

<u>Outerloop Power Control Info</u>	<u>Target UL Eb/lo</u>	=	=	=	=	=	<u>For L1 Power Control</u>
<u>Cause</u>	<u>Cause</u>	=	=	=	<u>m</u>	=	

\*1,\*2: Same as the previous.



<u>UL Radio Resources</u>	<u>UL scrambling code</u>	-	-	-	-	-	-	-	<u>Set UL Scrambling Code per UE</u>
	<u>UL spreading code type</u>	<u>m</u>	-	-	-	-	-	-	
	<u>No. of UL spreading code</u>	<u>m</u>	-	-	-	-	-	-	
	<u>UL spreading code id(s)</u>	<u>m</u>	-	-	-	-	-	-	
<u>DL Radio Resources</u>	<u>DL spreading code type</u>	<u>m</u>	-	-	-	-	-	-	<u>Same code type for all Radio Links</u>
	<u>No. of DL spreading code</u>	<u>m</u>	-	-	-	-	-	-	<u>Same number of codes for all Radio Links</u>
	<u>No. of Radio Links</u>	<u>m</u>	-	-	-	-	<u>m</u>	-	
	<u>Radio Link ID</u>	<u>m</u>	-	-	-	-	<u>m</u>	-	
	<u>Cell ID</u>	-	-	-	-	-	-	-	
	<u>Soft Combination Indicator</u>	-	-	-	-	-	-	-	<u>Indicates May, Must, Must not</u>
	<u>Phase Difference</u>	-	-	-	-	-	-	-	
	<u>:</u>								
	<u>Radio Link ID</u>	<u>o</u>	-	-	-	-	<u>o</u>	-	
	<u>Cell ID</u>	-	-	-	-	-	-	-	
	<u>Soft Combination Indicator</u>	-	-	-	-	-	-	-	
	<u>Phase Difference</u>	-	-	-	-	-	-	-	
<u>DL Radio Resources</u>	<u>No. of Radio Links</u>	-	<u>m</u>	-	-	-	-	-	
	<u>Radio Link ID</u>	-	<u>m</u>	-	-	-	-	-	
	<u>Neighbor Cell Information</u>	-	-	-	-	-	-	-	<b>FFS*2</b>
	<u>No. of DL spreading code</u>	-	<u>m</u>	-	-	-	-	-	
	<u>DL spreading code id #1</u>	-	<u>m</u>	-	-	-	-	-	
	<u>:</u>								
	<u>DL spreading code id #m</u>	-	<u>m</u>	-	-	-	-	-	
	<u>:</u>								
	<u>Radio Link ID</u>	-	<u>o</u>	-	-	-	-	-	
	<u>Neighbor Cell Information</u>	-	-	-	-	-	-	-	<b>FFS</b>
	<u>No. of DL spreading code</u>	-	<u>o</u>	-	-	-	-	-	
	<u>DL spreading code id #1</u>	-	<u>o</u>	-	-	-	-	-	
	<u>:</u>								
	<u>DL spreading code id #m</u>	-	<u>o</u>	-	-	-	-	-	
<u>Execution Time</u>	<u>Execution Time</u>	-	-	<u>m</u>	-	-	-	-	
<u>Offset Values</u>	<u>Slot offset</u>	-	-	-	-	-	-	-	
	<u>Frame offset</u>	-	-	-	-	-	-	-	
<u>Power Control Info</u>	<u>Initial DL Power</u>	-	-	-	-	-	-	-	<u>For Initial DL Power Setting</u>
	<u>DL Power Range</u>	-	-	-	-	-	-	-	<u>For Correcting DL Power Drifting during DHO</u>



4114

<u>Outerloop Power Control Info</u>	<u>Target UL Eb/lo</u>	-	-	-	-	-	-	-	<u>For L1 Power Control</u>
<u>Cause</u>	<u>Cause</u>	-	-	-	<u>m</u>	-	-	-	

\*1,\*2: Same as the previous.

**RRC Connection Release**

Parameter Category	Sub Parameters	Sub Message		Note
		<u>DCH to IDLE</u>		
		<u>RA</u>	<u>RA</u>	
		<u>DIO</u>	<u>DIO</u>	
		<u>LIN</u>	<u>LIN</u>	
		<u>K</u>	<u>K</u>	
		<u>DEL</u>	<u>DEL</u>	
		<u>ETI</u>	<u>ETI</u>	
		<u>ON</u>	<u>ON</u>	
			<u>RES</u>	
			<u>PO</u>	
			<u>NSE</u>	
<u>Transport CH Info</u>	<u>No. of DCHs</u>	-	-	
	<u>DCH ID (# 1)</u>	-	-	<u>DCH ID or each DCH</u>
	<u>TFS (for DCH ID# 1)</u>	-	-	<u>Set TFS when it is required</u>
	<u>:</u>			
	<u>DCH ID (# n)</u>	-	-	
	<u>TFS (for DCH ID# n)</u>	-	-	
	<u>TFCS (for DCHs)</u>	-	-	<u>Set TFCS per UE</u>
<u>Transport Layer Addressing Information</u>	<u>No. of DCHs</u>	-	-	
	<u>DCH ID (# 1)</u>	-	-	
	<u>ATM Binding ID</u>	-	-	<u>(TTC) 1 Binding ID for 1 DCH *1</u>
	<u>ATM Address</u>	-	-	
	<u>:</u>			
	<u>DCH ID (# n)</u>	-	-	
	<u>ATM Binding ID</u>	-	-	
	<u>ATM Address</u>	-	-	
<u>Radio Frequency Info</u>	<u>Radio Frequency</u>	-	-	<u>Set Radio Frequency per UE</u>
	<u>UL Interference Level</u>	-	-	
<u>UL Radio Resources</u>	<u>UL scrambling code</u>	-	-	<u>Set UL Scrambling Code per UE</u>
	<u>UL spreading code type</u>	-	-	
	<u>No. of UL spreading code</u>	-	-	
	<u>UL spreading code id(s)</u>	-	-	
<u>DL Radio Resources</u>	<u>DL spreading code type</u>	-	-	<u>Same code type for all Radio Links</u>

	<u>No. of DL spreading code</u>	-	-	<u>Same number of codes for all Radio Links</u>
	<u>No. of Radio Links</u>	<u>m</u>	-	
	<u>Radio Link ID</u>	<u>m</u>	-	
	<u>Cell ID</u>	-	-	
	<u>Soft Combination Indicator</u>	-	-	<u>Indicates May, Must, Must not</u>
	<u>Phase Difference</u>	-	-	
	<u>_____:</u>			
	<u>Radio Link ID</u>	<u>o</u>	-	
	<u>Cell ID</u>	-	-	
	<u>Soft Combination Indicator</u>	-	-	
	<u>Phase Difference</u>	-	-	
<u>DL Radio Resources</u>	<u>No. of Radio Links</u>	-	-	
	<u>Radio Link ID</u>	-	-	
	<u>Neighbor Cell Information</u>	-	-	<u>FFS*2</u>
	<u>No. of DL spreading code</u>	-	-	
	<u>DL spreading code id #1</u>	-	-	
	<u>_____:</u>			
	<u>DL spreading code id #m</u>	-	-	
	<u>_____:</u>			
	<u>Radio Link ID</u>	-	-	
	<u>Neighbor Cell Information</u>	-	-	<u>FFS</u>
	<u>No. of DL spreading code</u>	-	-	
	<u>DL spreading code id #1</u>	-	-	
	<u>_____:</u>			
	<u>DL spreading code id #m</u>	-	-	
<u>Execution Time</u>	<u>Execution Time</u>	-	-	
<u>Offset Values</u>	<u>Slot offset</u>	-	-	
	<u>Frame offset</u>	-	-	
<u>Power Control Info</u>	<u>Initial DL Power</u>	-	-	<u>For Initial DL Power Setting</u>
	<u>DL Power Range</u>	-	-	<u>For Correcting DL Power Drifting during DHO</u>
<u>Outerloop Power Control Info</u>	<u>Target UL Eb/lo</u>	-	-	<u>For L1 Power Control</u>

\*1,\*2: Same as the previous.



	ATM Address	-	o	-	-	o	-	-	-	-	-	
Radio Frequency Info	Radio Frequency	m	-	-	-	-	-	-	-	-	-	Set Radio Frequency per UE
	UL Interference Level	-	m	-	-	-	-	-	-	-	-	
UL Radio Resources	UL scrambling code	m	-	-	-	-	-	-	-	-	-	Set UL Scrambling Code per UE
	UL spreading code type	m	-	-	m	-	-	-	-	-	-	
	No. of UL spreading code	m	-	-	m	-	-	-	-	-	-	
	UL spreading code id(s)	m	-	-	m	-	-	-	-	-	-	
DL Radio Resources	DL spreading code type	m	-	-	m	-	-	-	-	-	-	Same code type for all Radio Links
	No. of DL spreading code	m	-	-	m	-	-	-	-	-	-	Same number of codes for all Radio Links
	No. of Radio Links	m	-	-	m	-	-	-	-	m	-	
	Radio Link ID	m	-	-	m	-	-	-	-	m	-	
	Cell ID	m	-	-	-	-	-	-	-	-	-	
	Soft Combination Indicator	-	-	-	-	-	-	-	-	-	-	Indicates May, Must, Must not
	Phase Difference	m	-	-	-	-	-	-	-	-	-	
	:											
	Radio Link ID	o	-	-	o	-	-	-	-	o	-	
	Cell ID	o	-	-	-	-	-	-	-	-	-	
	Soft Combination Indicator	o	-	-	-	-	-	-	-	-	-	
	Phase Difference	o	-	-	-	-	-	-	-	-	-	
DL Radio Resources	No. of Radio Links	-	m	-	-	m	-	-	-	-	-	
	Radio Link ID	-	m	-	-	m	-	-	-	-	-	
	Neighbor Cell Information	-	m	-	-	-	-	-	-	-	-	FFS*2
	No. of DL spreading code	-	m	-	-	m	-	-	-	-	-	
	DL spreading code id #1	-	m	-	-	m	-	-	-	-	-	
	:											
	DL spreading code id #m	-	m	-	-	m	-	-	-	-	-	
	:											
	Radio Link ID	-	o	-	-	o	-	-	-	-	-	
	Neighbor Cell Information	-	o	-	-	-	-	-	-	-	-	FFS
	No. of DL spreading code	-	o	-	-	o	-	-	-	-	-	
	DL spreading code id #1	-	o	-	-	o	-	-	-	-	-	
	:											
	DL spreading code id #m	-	o	-	-	o	-	-	-	-	-	
Execution Time	Execution Time	-	-	-	-	-	m	-	-	-	-	

<u>Offset Values</u>	<u>Slot offset</u>	<u>m</u>	-	-	-	-	-	-	-	-	-	
	<u>Frame offset</u>	<u>m</u>	-	-	-	-	-	-	-	-	-	
<u>Power Control Info</u>	<u>Initial DL Power</u>	<u>m</u>	-	-	-	-	-	-	-	-	-	<u>For Initial DL Power Setting</u>
	<u>DL Power Range</u>	-	-	-	-	-	-	-	-	-	-	<u>For Correcting DL Power Drifting during DHO</u>
<u>Outerloop Power Control Info</u>	<u>Target UL Eb/lo</u>	<u>m</u>	-	-	-	-	-	-	-	-	-	<u>For L1 Power Control</u>
<u>Cause</u>	<u>Cause</u>	-	-	<u>m</u>	-	-	-	<u>m</u>	-	-	-	

\*1,\*2: Same as the previous.



	ATM Address	-	o	-	-	-	-	-	-	-	-	
Radio Frequency Info	Radio Frequency	m	-	-	-	-	-	-	-	-	-	Set Radio Frequency per UE
	UL Interference Level	-	m	-	-	-	-	-	-	-	-	
UL Radio Resources	UL scrambling code	m	-	-	o	-	-	-	-	-	-	Set UL Scrambling Code per UE
	UL spreading code type	m	-	-	o	-	-	-	-	-	-	
	No. of UL spreading code	m	-	-	o	-	-	-	-	-	-	
	UL spreading code id(s)	m	-	-	o	-	-	-	-	-	-	
DL Radio Resources	DL spreading code type	m	-	-	o	-	-	-	-	-	-	Same code type for all Radio Links
	No. of DL spreading code	m	-	-	o	-	-	-	-	-	-	Same number of codes for all Radio Links
	No. of Radio Links	m	-	-	o	-	-	-	-	m	-	
	Radio Link ID	m	-	-	o	-	-	-	-	m	-	
	Cell ID	m	-	-	-	-	-	-	-	-	-	
	Soft Combination Indicator	-	-	-	-	-	-	-	-	-	-	Indicates May, Must, Must not
	Phase Difference	m	-	-	-	-	-	-	-	-	-	
	:											
	Radio Link ID	o	-	-	o	-	-	-	-	o	-	
	Cell ID	o	-	-	-	-	-	-	-	-	-	
	Soft Combination Indicator	o	-	-	-	-	-	-	-	-	-	
	Phase Difference	o	-	-	-	-	-	-	-	-	-	
DL Radio Resources	No. of Radio Links	-	m	-	-	m	-	-	-	-	-	
	Radio Link ID	-	m	-	-	m	-	-	-	-	-	
	Neighbor Cell Information	-	m	-	-	-	-	-	-	-	-	FFS*2
	No. of DL spreading code	-	m	-	-	m	-	-	-	-	-	
	DL spreading code id #1	-	m	-	-	m	-	-	-	-	-	
	:											
	DL spreading code id #m	-	m	-	-	m	-	-	-	-	-	
	:											
	Radio Link ID	-	o	-	-	o	-	-	-	-	-	
	Neighbor Cell Information	-	o	-	-	-	-	-	-	-	-	FFS
	No. of DL spreading code	-	o	-	-	o	-	-	-	-	-	
	DL spreading code id #1	-	o	-	-	o	-	-	-	-	-	
	:											
	DL spreading code id #m	-	o	-	-	o	-	-	-	-	-	
Execution Time	Execution Time	-	-	-	-	-	m	-	-	-	-	



<u>Offset Values</u>	<u>Slot offset</u>	<u>m</u>	-	-	-	-	-	-	-	-	-	
	<u>Frame offset</u>	<u>m</u>	-	-	-	-	-	-	-	-	-	
<u>Power Control Info</u>	<u>Initial DL Power</u>	<u>m</u>	-	-	-	-	-	-	-	-	-	<u>For Initial DL Power Setting</u>
	<u>DL Power Range</u>	-	-	-	-	-	-	-	-	-	-	<u>For Correcting DL Power Drifting during DHO</u>
<u>Outerloop Power Control Info</u>	<u>Target UL Eb/lo</u>	<u>m</u>	-	-	-	-	-	-	-	-	-	<u>For L1 Power Control</u>
<u>Cause</u>	<u>Cause</u>	-	-	<u>m</u>	-	-	-	-	<u>m</u>	-	-	

\*1,\*2: Same as the previous.

**Hard Handover (Inter-NodeB)**

Parameter Category	Iub Parameters	Iub Message					Note
		RA DIO LIN K SET UP	RA DIO LIN K SET UP RES PO NSE	RA DIO LIN K SET UP FAI LUR E	RA DIO LIN K DEL ETI ON	RA DIO LIN K DEL ETI ON RES PO NSE	
<u>Transport CH Info</u>	No. of DCHs	<u>m</u>	-	-	-	-	
	DCH ID (# 1)	<u>m</u>	-	-	-	-	DCH ID or each DCH
	TFS (for DCH ID# 1)	<u>m</u>	-	-	-	-	Set TFS when it is required
	⋮						
	DCH ID (# n)	<u>m</u>	-	-	-	-	
	TFS (for DCH ID# n)	<u>m</u>	-	-	-	-	
	TFCS (for DCHs)	<u>m</u>	-	-	-	-	Set TFCS per UE
<u>Transport Layer Addressing Information</u>	No. of DCHs	-	<u>m</u>	-	-	-	
	DCH ID (# 1)	-	<u>m</u>	-	-	-	
	ATM Binding ID	-	<u>m</u>	-	-	-	(TTC) 1 Binding ID for 1 DCH *1
	ATM Address	-	<u>o</u>	-	-	-	
	⋮						
	DCH ID (# n)	-	<u>m</u>	-	-	-	
	ATM Binding ID	-	<u>m</u>	-	-	-	
	ATM Address	-	<u>o</u>	-	-	-	
<u>Radio Frequency Info</u>	Radio Frequency	<u>m</u>	-	-	-	-	Set Radio Frequency per UE
	UL Interference Level	-	<u>m</u>	-	-	-	
<u>UL Radio Resources</u>	UL scrambling code	<u>m</u>	-	-	-	-	Set UL Scrambling Code per UE
	UL spreading code type	<u>m</u>	-	-	-	-	
	No. of UL spreading code	<u>m</u>	-	-	-	-	
	UL spreading code id(s)	<u>m</u>	-	-	-	-	
<u>DL Radio Resources</u>	DL spreading code type	<u>m</u>	-	-	-	-	Same code type for all Radio Links
	No. of DL spreading code	<u>m</u>	-	-	-	-	Same number of codes for all Radio Links

	<u>No. of Radio Links</u>	<u>m</u>	-	-	<u>m</u>	-	
	<u>Radio Link ID</u>	<u>m</u>	-	-	<u>m</u>	-	
	<u>Cell ID</u>	<u>m</u>	-	-	-	-	
	<u>Soft Combination Indicator</u>	-	-	-	-	-	<u>Indicates May, Must, Must not</u>
	<u>Phase Difference</u>	<u>m</u>	-	-	-	-	
	<u>:</u>						
	<u>Radio Link ID</u>	<u>o</u>	-	-	<u>o</u>	-	
	<u>Cell ID</u>	<u>o</u>	-	-	-	-	
	<u>Soft Combination Indicator</u>	<u>o</u>	-	-	-	-	
	<u>Phase Difference</u>	<u>o</u>	-	-	-	-	
<u>DL Radio Resources</u>	<u>No. of Radio Links</u>	-	<u>m</u>	-	-	-	
	<u>Radio Link ID</u>	-	<u>m</u>	-	-	-	
	<u>Neighbor Cell Information</u>	-	<u>m</u>	-	-	-	<u>FFS*2</u>
	<u>No. of DL spreading code</u>	-	<u>m</u>	-	-	-	
	<u>DL spreading code id #1</u>	-	<u>m</u>	-	-	-	
	<u>:</u>						
	<u>DL spreading code id #m</u>	-	<u>m</u>	-	-	-	
	<u>:</u>						
	<u>Radio Link ID</u>	-	<u>o</u>	-	-	-	
	<u>Neighbor Cell Information</u>	-	<u>o</u>	-	-	-	<u>FFS</u>
	<u>No. of DL spreading code</u>	-	<u>o</u>	-	-	-	
	<u>DL spreading code id #1</u>	-	<u>o</u>	-	-	-	
	<u>:</u>						
	<u>DL spreading code id #m</u>	-	<u>o</u>	-	-	-	
<u>Execution Time</u>	<u>Execution Time</u>	-	-	-	-	-	
<u>Offset Values</u>	<u>Slot offset</u>	<u>m</u>	-	-	-	-	
	<u>Frame offset</u>	<u>m</u>	-	-	-	-	
<u>Power Control Info</u>	<u>Initial DL Power</u>	<u>m</u>	-	-	-	-	<u>For Initial DL Power Setting</u>
	<u>DL Power Range</u>	-	-	-	-	-	<u>For Correcting DL Power Drifting during DHO</u>
<u>Outerloop Power Control Info</u>	<u>Target UL Eb/lo</u>	<u>m</u>	-	-	-	-	<u>For L1 Power Control</u>
<u>Cause</u>	<u>Cause</u>	-	-	<u>m</u>	-	-	

\*1,\*2: Same as the previous.

**Hard Handover (Intra-NodeB)**

Parameter Category	Iub Parameters	Iub Message					Note
		RA DIO LIN K AD DITI ON	RA DIO LIN K AD DITI ON RES PO NSE	RA DIO LIN K AD DITI ON FAI LUR E	RA DIO LIN K DEL ETI ON	RA DIO LIN K DEL ETI ON RES PO NSE	
<u>Transport CH Info</u>	No. of DCHs	-	-	-	-	-	
	DCH ID (# 1)	-	-	-	-	-	DCH ID or each DCH
	TFS (for DCH ID# 1)	-	-	-	-	-	Set TFS when it is required
	⋮						
	DCH ID (# n)	-	-	-	-	-	
	TFS (for DCH ID# n)	-	-	-	-	-	
	TFCS (for DCHs)	-	-	-	-	-	Set TFCS per UE
<u>Transport Layer Addressing Information</u>	No. of DCHs	-	<u>m</u>	-	-	-	
	DCH ID (# 1)	-	<u>m</u>	-	-	-	
	ATM Binding ID	-	<u>m</u>	-	-	-	(TTC) 1 Binding ID for 1 DCH *1
	ATM Address	-	<u>o</u>	-	-	-	
	⋮						
	DCH ID (# n)	-	<u>m</u>	-	-	-	
	ATM Binding ID	-	<u>m</u>	-	-	-	
	ATM Address	-	<u>o</u>	-	-	-	
<u>Radio Frequency Info</u>	Radio Frequency	<u>o</u>	-	-	-	-	Set Radio Frequency per UE
	UL Interference Level	-	<u>m</u>	-	-	-	
<u>UL Radio Resources</u>	UL scrambling code	-	-	-	-	-	Set UL Scrambling Code per UE
	UL spreading code type	-	-	-	-	-	
	No. of UL spreading code	-	-	-	-	-	
	UL spreading code id(s)	-	-	-	-	-	
<u>DL Radio Resources</u>	DL spreading code type	-	-	-	-	-	Same code type for all Radio Links
	No. of DL spreading code	-	-	-	-	-	Same number of codes for all Radio Links

	<u>No. of Radio Links</u>	<u>m</u>	-	-	<u>m</u>	-	
	<u>Radio Link ID</u>	<u>m</u>	-	-	<u>m</u>	-	
	<u>Cell ID</u>	<u>m</u>	-	-	-	-	
	<u>Soft Combination Indicator</u>	<u>m</u>	-	-	-	-	<u>Indicates May, Must, Must not</u>
	<u>Phase Difference</u>	<u>m</u>	-	-	-	-	
	<u>:</u>						
	<u>Radio Link ID</u>	<u>o</u>	-	-	<u>o</u>	-	
	<u>Cell ID</u>	<u>o</u>	-	-	-	-	
	<u>Soft Combination Indicator</u>	<u>o</u>	-	-	-	-	
	<u>Phase Difference</u>	<u>o</u>	-	-	-	-	
<u>DL Radio Resources</u>	<u>No. of Radio Links</u>	-	<u>m</u>	-	-	-	
	<u>Radio Link ID</u>	-	<u>m</u>	-	-	-	
	<u>Neighbor Cell Information</u>	-	<u>m</u>	-	-	-	<u>FFS*2</u>
	<u>No. of DL spreading code</u>	-	<u>m</u>	-	-	-	
	<u>DL spreading code id #1</u>	-	<u>m</u>	-	-	-	
	<u>:</u>						
	<u>DL spreading code id #m</u>	-	<u>m</u>	-	-	-	
	<u>:</u>						
	<u>Radio Link ID</u>	-	<u>o</u>	-	-	-	
	<u>Neighbor Cell Information</u>	-	<u>o</u>	-	-	-	<u>FFS</u>
	<u>No. of DL spreading code</u>	-	<u>o</u>	-	-	-	
	<u>DL spreading code id #1</u>	-	<u>o</u>	-	-	-	
	<u>:</u>						
	<u>DL spreading code id #m</u>	-	<u>o</u>	-	-	-	
<u>Execution Time</u>	<u>Execution Time</u>	-	-	-	-	-	
<u>Offset Values</u>	<u>Slot offset</u>	-	-	-	-	-	
	<u>Frame offset</u>	-	-	-	-	-	
<u>Power Control Info</u>	<u>Initial DL Power</u>	-	-	-	-	-	<u>For Initial DL Power Setting</u>
	<u>DL Power Range</u>	-	-	-	-	-	<u>For Correcting DL Power Drifting during DHO</u>
<u>Outerloop Power Control Info</u>	<u>Target UL Eb/lo</u>	-	-	-	-	-	<u>For L1 Power Control</u>
<u>Cause</u>	<u>Cause</u>	-	-	<u>m</u>	-	-	

\*1,\*2: Same as the previous.

**Handover Radio Link Addition (Inter-NodeB)**

Parameter Category	Iub Parameters	Iub Message			Note
		RA DIO LIN K SET UP	RA DIO LIN K SET UP RES PO NSE	RA DIO LIN K SET UP FAI LUR E	
<u>Transport CH Info</u>	No. of DCHs	<u>m</u>	-	-	
	DCH ID (# 1)	<u>m</u>	-	-	DCH ID or each DCH
	TFS (for DCH ID# 1)	<u>m</u>	-	-	Set TFS when it is required
	⋮				
	DCH ID (# n)	<u>m</u>	-	-	
	TFS (for DCH ID# n)	<u>m</u>	-	-	
	TFCS (for DCHs)	<u>m</u>	-	-	Set TFCS per UE
<u>Transport Layer Addressing Information</u>	No. of DCHs	-	<u>m</u>	-	
	DCH ID (# 1)	-	<u>m</u>	-	
	ATM Binding ID	-	<u>m</u>	-	(TTC) 1 Binding ID for 1 DCH *1
	ATM Address	-	<u>o</u>	-	
	⋮				
	DCH ID (# n)	-	<u>m</u>	-	
	ATM Binding ID	-	<u>m</u>	-	
	ATM Address	-	<u>o</u>	-	
<u>Radio Frequency Info</u>	Radio Frequency	<u>m</u>	-	-	Set Radio Frequency per UE
	UL Interference Level	-	<u>m</u>	-	
<u>UL Radio Resources</u>	UL scrambling code	<u>m</u>	-	-	Set UL Scrambling Code per UE
	UL spreading code type	<u>m</u>	-	-	
	No. of UL spreading code	<u>m</u>	-	-	
	UL spreading code id(s)	<u>m</u>	-	-	
<u>DL Radio Resources</u>	DL spreading code type	<u>m</u>	-	-	Same code type for all Radio Links
	No. of DL spreading code	<u>m</u>	-	-	Same number of codes for all Radio Links
	No. of Radio Links	<u>m</u>	-	-	

	<u>Radio Link ID</u>	<u>m</u>	-	-	
	<u>Cell ID</u>	<u>m</u>	-	-	
	<u>Soft Combination Indicator</u>	-	-	-	<u>Indicates May, Must, Must not</u>
	<u>Phase Difference</u>	<u>m</u>	-	-	
	<u>_____:</u>				
	<u>Radio Link ID</u>	<u>o</u>	-	-	
	<u>Cell ID</u>	<u>o</u>	-	-	
	<u>Soft Combination Indicator</u>	<u>o</u>	-	-	
	<u>Phase Difference</u>	<u>o</u>	-	-	
<u>DL Radio Resources</u>	<u>No. of Radio Links</u>	-	<u>m</u>	-	
	<u>Radio Link ID</u>	-	<u>m</u>	-	
	<u>Neighbor Cell Information</u>	-	<u>m</u>	-	<u>FFS*2</u>
	<u>No. of DL spreading code</u>	-	<u>m</u>	-	
	<u>DL spreading code id #1</u>	-	<u>m</u>	-	
	<u>_____:</u>				
	<u>DL spreading code id #m</u>	-	<u>m</u>	-	
	<u>_____:</u>				
	<u>Radio Link ID</u>	-	<u>o</u>	-	
	<u>Neighbor Cell Information</u>	-	<u>o</u>	-	<u>FFS</u>
	<u>No. of DL spreading code</u>	-	<u>o</u>	-	
	<u>DL spreading code id #1</u>	-	<u>o</u>	-	
	<u>_____:</u>				
	<u>DL spreading code id #m</u>	-	<u>o</u>	-	
<u>Execution Time</u>	<u>Execution Time</u>	-	-	-	
<u>Offset Values</u>	<u>Slot offset</u>	<u>m</u>	-	-	
	<u>Frame offset</u>	<u>m</u>	-	-	
<u>Power Control Info</u>	<u>Initial DL Power</u>	<u>m</u>	-	-	<u>For Initial DL Power Setting</u>
	<u>DL Power Range</u>	-	-	-	<u>For Correcting DL Power Drifting during DHO</u>
<u>Outerloop Power Control Info</u>	<u>Target UL Eb/lo</u>	<u>m</u>	-	-	<u>For L1 Power Control</u>
<u>Cause</u>	<u>Cause</u>	-	-	<u>m</u>	

\*1,\*2: Same as the previous.

**Handover Radio Link Addition (Intra-NodeB)**

Parameter Category	Iub Parameters	Iub Message			Note
		RA DIO LIN K AD DITI ON	RA DIO LIN K AD DITI ON RES PO NSE	RA DIO LIN K AD DITI ON FAI LUR E	
<u>Transport CH Info</u>	No. of DCHs	-	-	-	
	DCH ID (# 1)	-	-	-	DCH ID or each DCH
	TFS (for DCH ID# 1)	-	-	-	Set TFS when it is required
	⋮				
	DCH ID (# n)	-	-	-	
	TFS (for DCH ID# n)	-	-	-	
	TFCS (for DCHs)	-	-	-	Set TFCS per UE
<u>Transport Layer Addressing Information</u>	No. of DCHs	-	m	-	
	DCH ID (# 1)	-	m	-	
	ATM Binding ID	-	m	-	(TTC) 1 Binding ID for 1 DCH *1
	ATM Address	-	o	-	
	⋮				
	DCH ID (# n)	-	m	-	
	ATM Binding ID	-	m	-	
	ATM Address	-	o	-	
<u>Radio Frequency Info</u>	Radio Frequency	o	-	-	Set Radio Frequency per UE
	UL Interference Level	-	m	-	
<u>UL Radio Resources</u>	UL scrambling code	-	-	-	Set UL Scrambling Code per UE
	UL spreading code type	-	-	-	
	No. of UL spreading code	-	-	-	
	UL spreading code id(s)	-	-	-	
<u>DL Radio Resources</u>	DL spreading code type	-	-	-	Same code type for all Radio Links
	No. of DL spreading code	-	-	-	Same number of codes for all Radio Links



	<u>No. of Radio Links</u>	<u>m</u>	-	-	
	<u>Radio Link ID</u>	<u>m</u>	-	-	
	<u>Cell ID</u>	<u>m</u>	-	-	
	<u>Soft Combination Indicator</u>	<u>m</u>	-	-	<u>Indicates May, Must, Must not</u>
	<u>Phase Difference</u>	<u>m</u>	-	-	
	<u>:</u>				
	<u>Radio Link ID</u>	<u>o</u>	-	-	
	<u>Cell ID</u>	<u>o</u>	-	-	
	<u>Soft Combination Indicator</u>	<u>o</u>	-	-	
	<u>Phase Difference</u>	<u>o</u>	-	-	
<u>DL Radio Resources</u>	<u>No. of Radio Links</u>	-	<u>m</u>	-	
	<u>Radio Link ID</u>	-	<u>m</u>	-	
	<u>Neighbor Cell Information</u>	-	<u>m</u>	-	<u>FFS*2</u>
	<u>No. of DL spreading code</u>	-	<u>m</u>	-	
	<u>DL spreading code id #1</u>	-	<u>m</u>	-	
	<u>:</u>				
	<u>DL spreading code id #m</u>	-	<u>m</u>	-	
	<u>:</u>				
	<u>Radio Link ID</u>	-	<u>o</u>	-	
	<u>Neighbor Cell Information</u>	-	<u>o</u>	-	<u>FFS</u>
	<u>No. of DL spreading code</u>	-	<u>o</u>	-	
	<u>DL spreading code id #1</u>	-	<u>o</u>	-	
	<u>:</u>				
	<u>DL spreading code id #m</u>	-	<u>o</u>	-	
<u>Execution Time</u>	<u>Execution Time</u>	-	-	-	
<u>Offset Values</u>	<u>Slot offset</u>	-	-	-	
	<u>Frame offset</u>	-	-	-	
<u>Power Control Info</u>	<u>Initial DL Power</u>	-	-	-	<u>For Initial DL Power Setting</u>
	<u>DL Power Range</u>	-	-	-	<u>For Correcting DL Power Drifting during DHO</u>
<u>Outerloop Power Control Info</u>	<u>Target UL Eb/lo</u>	-	-	-	<u>For L1 Power Control</u>
<u>Cause</u>	<u>Cause</u>	-	-	<u>m</u>	

\*1,\*2: Same as the previous.

**Handover Radio Link Deletion (Inter-NodeB)**

Parameter Category	Iub Parameters	Iub Message		Note
		<u>RA</u> <u>DIO</u> <u>LIN</u> <u>K</u> <u>DEL</u> <u>ETI</u> <u>ON</u>	<u>RA</u> <u>DIO</u> <u>LIN</u> <u>K</u> <u>DEL</u> <u>ETI</u> <u>ON</u> <u>RES</u> <u>PO</u> <u>NSE</u>	
<u>Transport CH Info</u>	<u>No. of DCHs</u>	-	-	
	<u>DCH ID (# 1)</u>	-	-	<u>DCH ID or each DCH</u>
	<u>TFS (for DCH ID# 1)</u>	-	-	<u>Set TFS when it is required</u>
	<u>:</u>			
	<u>DCH ID (# n)</u>	-	-	
	<u>TFS (for DCH ID# n)</u>	-	-	
	<u>TFCS (for DCHs)</u>	-	-	<u>Set TFCS per UE</u>
<u>Transport Layer Addressing Information</u>	<u>No. of DCHs</u>	-	-	
	<u>DCH ID (# 1)</u>	-	-	
	<u>ATM Binding ID</u>	-	-	<u>(TTC) 1 Binding ID for 1 DCH *1</u>
	<u>ATM Address</u>	-	-	
	<u>:</u>			
	<u>DCH ID (# n)</u>	-	-	
	<u>ATM Binding ID</u>	-	-	
	<u>ATM Address</u>	-	-	
<u>Radio Frequency Info</u>	<u>Radio Frequency</u>	-	-	<u>Set Radio Frequency per UE</u>
	<u>UL Interference Level</u>	-	-	
<u>UL Radio Resources</u>	<u>UL scrambling code</u>	-	-	<u>Set UL Scrambling Code per UE</u>
	<u>UL spreading code type</u>	-	-	
	<u>No. of UL spreading code</u>	-	-	
	<u>UL spreading code id(s)</u>	-	-	
<u>DL Radio Resources</u>	<u>DL spreading code type</u>	-	-	<u>Same code type for all Radio Links</u>
	<u>No. of DL spreading code</u>	-	-	<u>Same number of codes for all Radio Links</u>

	<u>No. of Radio Links</u>	<u>m</u>	-	
	<u>Radio Link ID</u>	<u>m</u>	-	
	<u>Cell ID</u>	-	-	
	<u>Soft Combination Indicator</u>	-	-	<u>Indicates May, Must, Must not</u>
	<u>Phase Difference</u>	-	-	
	<u>:</u>			
	<u>Radio Link ID</u>	<u>o</u>	-	
	<u>Cell ID</u>	-	-	
	<u>Soft Combination Indicator</u>	-	-	
	<u>Phase Difference</u>	-	-	
<u>DL Radio Resources</u>	<u>No. of Radio Links</u>	-	-	
	<u>Radio Link ID</u>	-	-	
	<u>Neighbor Cell Information</u>	-	-	<b>FFS*2</b>
	<u>No. of DL spreading code</u>	-	-	
	<u>DL spreading code id #1</u>	-	-	
	<u>:</u>			
	<u>DL spreading code id #m</u>	-	-	
	<u>:</u>			
	<u>Radio Link ID</u>	-	-	
	<u>Neighbor Cell Information</u>	-	-	<b>FFS</b>
	<u>No. of DL spreading code</u>	-	-	
	<u>DL spreading code id #1</u>	-	-	
	<u>:</u>			
	<u>DL spreading code id #m</u>	-	-	
<u>Execution Time</u>	<u>Execution Time</u>	-	-	
<u>Offset Values</u>	<u>Slot offset</u>	-	-	
	<u>Frame offset</u>	-	-	
<u>Power Control Info</u>	<u>Initial DL Power</u>	-	-	<u>For Initial DL Power Setting</u>
	<u>DL Power Range</u>	-	-	<u>For Correcting DL Power Drifting during DHO</u>
<u>Outerloop Power Control Info</u>	<u>Target UL Eb/lo</u>	-	-	<u>For L1 Power Control</u>

\*1,\*2: Same as the previous.

**Handover Radio Link Deletion (Intra-NodeB)**

Parameter Category	Sub Parameters	Sub Message		Note
		<u>RA</u> <u>DIO</u> <u>LIN</u> <u>K</u> <u>DEL</u> <u>ETI</u> <u>ON</u>	<u>RA</u> <u>DIO</u> <u>LIN</u> <u>K</u> <u>DEL</u> <u>ETI</u> <u>ON</u> <u>RES</u> <u>PO</u> <u>NSE</u>	
<u>Transport CH Info</u>	<u>No. of DCHs</u>	-	-	
	<u>DCH ID (# 1)</u>	-	-	<u>DCH ID or each DCH</u>
	<u>TFS (for DCH ID# 1)</u>	-	-	<u>Set TFS when it is required</u>
	<u>:</u>			
	<u>DCH ID (# n)</u>	-	-	
	<u>TFS (for DCH ID# n)</u>	-	-	
	<u>TFCS (for DCHs)</u>	-	-	<u>Set TFCS per UE</u>
<u>Transport Layer Addressing Information</u>	<u>No. of DCHs</u>	-	-	
	<u>DCH ID (# 1)</u>	-	-	
	<u>ATM Binding ID</u>	-	-	<u>(TTC) 1 Binding ID for 1 DCH *1</u>
	<u>ATM Address</u>	-	-	
	<u>:</u>			
	<u>DCH ID (# n)</u>	-	-	
	<u>ATM Binding ID</u>	-	-	
	<u>ATM Address</u>	-	-	
<u>Radio Frequency Info</u>	<u>Radio Frequency</u>	-	-	<u>Set Radio Frequency per UE</u>
	<u>UL Interference Level</u>	-	-	
<u>UL Radio Resources</u>	<u>UL scrambling code</u>	-	-	<u>Set UL Scrambling Code per UE</u>
	<u>UL spreading code type</u>	-	-	
	<u>No. of UL spreading code</u>	-	-	
	<u>UL spreading code id(s)</u>	-	-	
<u>DL Radio Resources</u>	<u>DL spreading code type</u>	-	-	<u>Same code type for all Radio Links</u>
	<u>No. of DL spreading code</u>	-	-	<u>Same number of codes for all Radio Links</u>

	<u>No. of Radio Links</u>	<u>m</u>	-	
	<u>Radio Link ID</u>	<u>m</u>	-	
	<u>Cell ID</u>	-	-	
	<u>Soft Combination Indicator</u>	-	-	<u>Indicates May, Must, Must not</u>
	<u>Phase Difference</u>	-	-	
	<u>:</u>			
	<u>Radio Link ID</u>	<u>o</u>	-	
	<u>Cell ID</u>	-	-	
	<u>Soft Combination Indicator</u>	-	-	
	<u>Phase Difference</u>	-	-	
<u>DL Radio Resources</u>	<u>No. of Radio Links</u>	-	-	
	<u>Radio Link ID</u>	-	-	
	<u>Neighbor Cell Information</u>	-	-	<b>FFS*2</b>
	<u>No. of DL spreading code</u>	-	-	
	<u>DL spreading code id #1</u>	-	-	
	<u>:</u>			
	<u>DL spreading code id #m</u>	-	-	
	<u>:</u>			
	<u>Radio Link ID</u>	-	-	
	<u>Neighbor Cell Information</u>	-	-	<b>FFS</b>
	<u>No. of DL spreading code</u>	-	-	
	<u>DL spreading code id #1</u>	-	-	
	<u>:</u>			
	<u>DL spreading code id #m</u>	-	-	
<u>Execution Time</u>	<u>Execution Time</u>	-	-	
<u>Offset Values</u>	<u>Slot offset</u>	-	-	
	<u>Frame offset</u>	-	-	
<u>Power Control Info</u>	<u>Initial DL Power</u>	-	-	<u>For Initial DL Power Setting</u>
	<u>DL Power Range</u>	-	-	<u>For Correcting DL Power Drifting during DHO</u>
<u>Outerloop Power Control Info</u>	<u>Target UL Eb/lo</u>	-	-	<u>For L1 Power Control</u>

\*1,\*2: Same as the previous.

**Power Control**

<u>Parameter Category</u>	<u>Sub Parameters</u>	<u>Sub Message</u>	<u>Note</u>
		<u>POWER</u> <u>CONTROL</u> <u>L</u>	
<u>Power Control Info</u>	<u>Initial DL Power</u>	<u>-</u>	<u>For Initial DL Power Setting</u>
	<u>DL Power Range</u>	<u>o</u>	<u>For Correcting DL Power</u> <u>Drifting during DHO</u>

Outer-loop Power Control

<u>Parameter Category</u>	<u>Iub Parameters</u>	<u>Iub Message</u>	<u>Note</u>
		<u>OUTER- LOOP POWR CONTRO L</u>	
<u>Outerloop Power Control Info</u>	<u>Target UL Eb/lo</u>	<u>o</u>	<u>For L1 Power Control</u>

---